

ALTOSONIC V Installation Manual

ALTOSONIC V

5-beam ultrasonic flowmetering system

Operating and installation instructions

UFC-V/...-EEx Flow Converter

UFS 500 F/5STR-EEx Flow Sensor

UFP-V Flow Processor

ALTOSONIC V

Ultrasonic flow Processor

Electrical & Mechanical Installation

Software Version 0300

General advice on safety

- Do not install, operate or maintain this flowmeter without reading, understanding and following the factory-supplied instructions, otherwise injury or damage may result.
- Read these instructions carefully before starting installation and save them for future reference.
- Observe all warnings and instructions marked on the instrument.
- Use only mains supply with protective earthing connected.
- Do not use the instrument with removed covers under wet conditions.
- Consider handling and lifting instructions to avoid damage.
- Install the product securely and stable.
- Install and connect cabling proper to exclude damage or harmful situations.
- If the instrument does not operate normally, refer to the service instructions or refer to qualified KROHNE service engineers.
- There are no operator-serviceable parts inside the instrument.

The following symbols may appear in this manual or on the instrument:



ATTENTION: Refer to operating and installation instructions!



DANGER: Risk of electric shock!



PROTECTIVE EARTH (PE) conductor terminal!



These terms may appear in this manual and/or on the instrument:

WARNING statement: Identify conditions or practice that could result in injury or loss of life.



CAUTION statement: Identify conditions or practice that could result in damage to the product or other property.

Disclaimer

This document contains important information on the instrument. KROHNE attempts to be as accurate and up-to-date as possible but assumes no responsibility for errors or omissions. Nor does KROHNE make any commitment to update the information contained herein. This manual and all other documents are subject to change without prior notice.

KROHNE will not be liable for any damage of any kind by using its instrument, including, but not limited to direct, indirect, incidental, punitive and consequential damages.

This disclaimer does not apply in case KROHNE has acted on purpose or with gross negligence. In the event any applicable law does not allow such limitations on implied warranties or the exclusion of limitation of certain damages, you may, if such law applies to you, not be subject to some or all of the above disclaimer, exclusions or limitations.

Any instrument purchased from KROHNE is warranted in accordance with the relevant product documentation and our Terms and Conditions of Sale.

KROHNE reserves the right to alter the content of its documents, including this disclaimer in any way, at any time, for any reason, without prior notification, and will not be liable in any way for possible consequences of such changes.

Product liability and warranty

Responsibility for suitability and intended use of this ultrasonic flow meter rests solely with the user. Improper installation and operation of the flow meter (system) may lead to loss of warranty.

In addition, the Terms and Conditions of Sale are applicable and are the basis for the purchase contract.

If flow meters need to be returned to KROHNE, please note the information given on the last pages of the installation and operating instructions. KROHNE regrets that they cannot repair or check flow meter(s) unless accompanied by the completed form (see last pages of the installation and operating instructions).

Items supplied

Standard (OIML type tested)

- 1x UFS 500 F/5STR-EEEx ultrasonic flow tube, in the size as indicated on the packaging box, including 4 certified EEx i M20X1,5 cable glands in connection box: 3 for the sensor cables and 1 for the PT100 sensor to measure the body temperature.
- 1x UFC-V/EEEx (standard or with optional 30 W heater) or UFC-V/LT-EEEx (low-temperature) ultrasonic Flow Converter, containing 5 UFC 500 converters and if ordered a heating device, including 3 certified EEx d M20X1,5 cable glands in junction box for connecting supplied coaxial cable.
- 3x Sensor cables with 4 coaxial cables, each with preassembled SMB connectors for the interconnection of the ultrasonic transducers of the UFS-V to the converter electronics of the UFC-V, standard **length 5 or 10 meters, flame retardant according IEC 332-1 3rd.**

Optional

- 1x Flow processor UFP-V, 19" rack version to process the flow, temperature, pressure and density signals into a volume flow output as well as internal totalizers and Modbus data.
- 1x 19" I/O-rack. This rack contains all the connection terminals to the I/O devices. It contains the ordered I/O modules which are interfaced to the UFP-V Flow Processor. This part is custom pre-wired and also ready to use.

Documentation supplied

- Operating and installation instructions
- Approval documents, unless reproduced in the installation and operating instructions
- Report of factory settings of the flow converter
- Certificate of system calibration data

This instrument is developed and manufactured by:

KROHNE Altometer
Kerkeplaat 12
3313 LC Dordrecht
The Netherlands

For information, maintenance or service please contact your nearest local KROHNE representative or refer to our website www.krohne.com.



No changes may be made to the devices. Unauthorized changes might affect the explosion safety of the devices.
Be sure to follow these instructions!

Table of Contents

1.	Introduction	6
1.1	Cautions	6
1.2	Unpacking and inspection	6
1.3	System description	7
1.4	Approvals	8
1.5	Safety instructions	8
2.	Mechanical installation	10
2.1	Ultrasonic Flow Sensor (UFS-V).....	10
2.2	Ultrasonic Flow Converter UFC-V.....	11
2.3	Ultrasonic Flow Processor UFP-V including I/O rack	12
3.	Electrical installation	13
3.1	Overview of connections.....	13
3.2	Installation location and wiring considerations.....	13
3.3	Power connection	14
3.4	Connecting Flow Sensor to Flow Converter	15
3.5	Connecting Flow Sensor to the Flow Computer	18
3.6	Connecting the Flow Converter to the Flow Computer	19
3.7	Connecting the I/O-rack to the Flow Computer UFP-V	20
3.8	Connecting the outputs of the UFP-V I/O-rack	21
3.9	Computer and I/O rack	23
3.10	Modbus connection/communication to external equipment.....	28
4.	Returning the flowmeter for service or repair	29

1. Introduction

1.1 Cautions

Refer all maintenance or service to trained KROHNE service engineers. Mains power shall be disconnected from the product before performing any maintenance. This product is prepared for and can only function with the rated mains voltage as indicated on the type plate. This product is a Class 1 device (earthed) and requires a correct connection to protective earth. The protective earth conductor of the main power shall be properly connected to the marked protective earth terminal to ensure safety from electric shock for the operator and its environment.

1.2 Unpacking and inspection

This product has been thoroughly inspected and tested before shipment and is ready for operation. After carefully unpacking, inspect for shipping damage before attempting to operate. If any indication of mechanical damage is found, immediately contact the responsible transport service and KROHNE.

A simple operating check of the electronics after unpacking and before permanent installation is advisable to ascertain whether it has suffered damage during shipment. Confirm for the correct mains voltage printed on the type plate. If it differs from the ordered product please contact KROHNE.

After connecting to the mains, check if there is any indication on the display and if the backlight of the display is lighted. If not contact your local KROHNE representative for advice.

1.3 System description

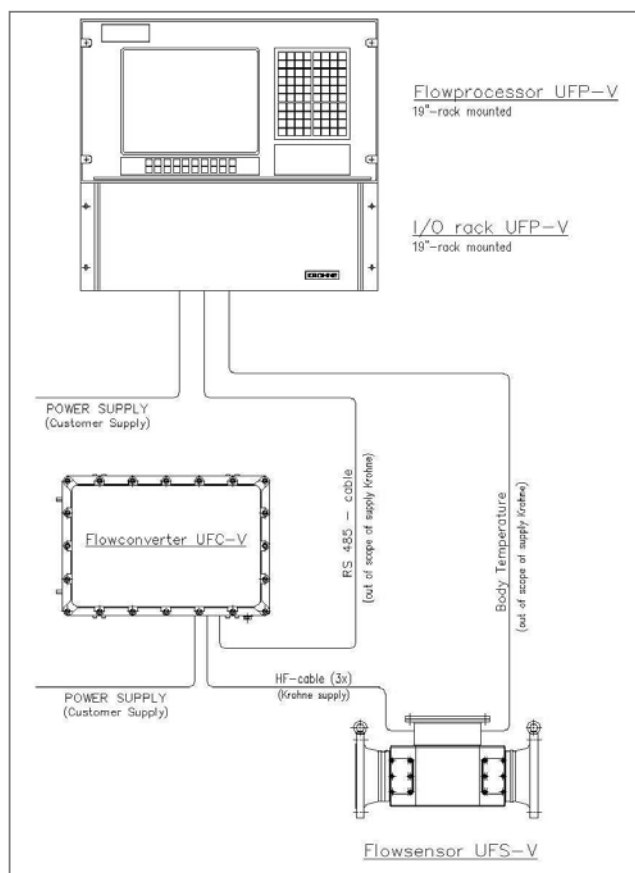

The ALTOSONIC V is a high precision instrument designed for linear, bi/directional flow measurement of liquids. The ALTOSONIC V is partly positioned in a potential hazardous environment and partly in a non-hazardous environment.

The Flow Sensor UFS-V and the Flow Converter UFC-V are designed and factory prepared to function in a potential explosive environment. Housings and cable glands are certified types and have to be handled in accordance with the specifications.

The remaining (optional) components of the ALTOSONIC V system, the Flow Processor UFP-V and the supplied I/O rack configuration may only be operated in a safe non-hazardous area. The I/O rack contains the additional I/O modules for a safe separation between hazardous and non-hazardous environment. In this chapter the electrical connections between the different parts of the installation are discussed.

Some additional material, that is not in the scope of supply, is required for connecting the PT100 in the Flow Sensor UFS-V to the Flow Computer UFP-V I/O-rack, the RS485 connection between the Flow Converter UFC-V and the Flow Computer UFP-V I/O-rack and the power supply of the Flow Converter UFC-V.

- Cables from the body temperature sensor Pt 100 of the UFS-V to the I/O temperature module in I/O-rack 4 wire shielded twisted pairs
- The RS485 data connection between the Flow Converter UFC-V and the Flow Processor UFP-V

- 3 wire shielded wire twisted (or two pairs)
- Power supply to the I/O-rack: 3 wire including PE for protective earthing.
- The Flow Converter UFC-V cabling in hazardous area containing L, N and PE, according to EN IEC 60079-14
- Ex equipotential bonding conductor between UFC-V and UFS-V $\geq 4 \text{ mm}^2$
- I/O cabling to external equipment screened twisted pairs
- Cable glands for the power supply and communication of the UFC-V
- There are four M20X1,5 cable entrances closed with certified blind plugs, cable glands shall be of a certified type guaranteeing EEx -d protection

1.4 Approvals

EMC, Electromagnetic Compatibility Directive

The ALTOSONIC V flowmeter system complies with the requirements of the harmonized standards under the EMC directive 89/336/EEC.

Pressure Equipment Directive

The KROHNE organization complies with the requirements of Module H of the Pressure Equipment Directive 97/23/EC (full quality assurance).

ATEX Directive 94/9/EC

Both the Flow Sensor and the Flow Converter are in compliance with the European Directive 94/9 EG (i.e. ATEX 100A). Please see the addition to the Operating and Installation Instructions for details about use in hazardous areas.

1.5 Safety instructions

The hazardous area equipment (i.e. the UFS-V and UFC-V components) must be handled in accordance with the addition to the Operating and Installation Instructions for use in hazardous areas. For the non-hazardous area equipment (UFP-V and I/O rack) the following applies:



This product is designed for use in accordance with EN IEC 61010-1 for Installation Category 2 and Pollution Degree 2. Hazardous voltages are present within this product during normal operation. The product is designed for Protection Class I and should never be operated without protective earth. The product shall also never be operated with covers removed unless equivalent protection of the operator and its environment from accidental contact with hazardous internal voltages is provided. Always follow basic and local safety precautions when using this product to reduce risk of injury from electrical shock, spread of fire or other dangerous situations.



This instrument is intended for permanent connection to the mains. It is required (for example for service) to mount an external switch or circuit breaker near the product for disconnection from the mains. This must be easily reachable by the operator and marked as the disconnecting device for this product. The switch or circuit breaker has to be suitable for the application and shall also be in accordance with to local (safety) requirements and of the building installation (IEC 60947-1/-3).



It is not allowed to use the protective conductor terminal for any other connection than the protective earth conductor.

The IP grade is only warranted when using suitable cabling with the cable glands and covers mounted as specified if applicable.

The UFP-V Flow Processor and I/O rack are designed to operate safely under the following conditions:

- Indoor use or mounted in a suitable housing usable up to protection category according EN IEC 60529 of the housing
- Use up to an altitude of 2000 m above sea level
- Operation ambient temperature range 0°C to +50°C
- Use with a relative humidity of 5 ~ 85% @ 50°C non-condensing
- Storage temperature range: -20°C to + 70°C
- Mains supply voltage fluctuations up to -15 and +10% of the specified voltage range
- Over voltages up to category II on the main supply voltage (IEC 60364-4-443)
- Connected to protective earth conductor (Protection Class I)
- Rated pollution degree 2

2. Mechanical installation

2.1 Ultrasonic Flow Sensor (UFS-V)

Handling

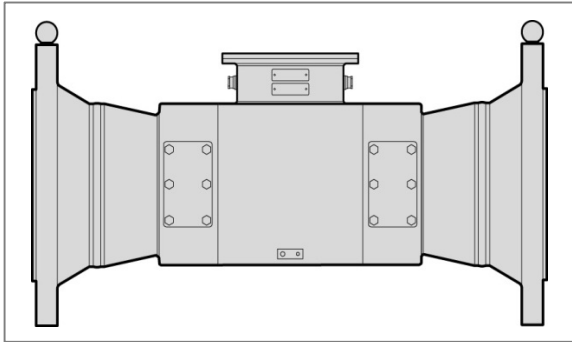

Check weight as indicated on the type plate before handling the unit.
When handling avoid hard blows, jolts or impacts.
Use suitable lifting equipment and use the provided lifting eyebolts or the lifting points.
Avoid damaging the sealing of the sensor covers.

Installation location and position

As the ALTOSONIC V is used in hydro carbon pipe lines, be aware of potentially explosive atmospheres. Local standards and regulations must be respected.

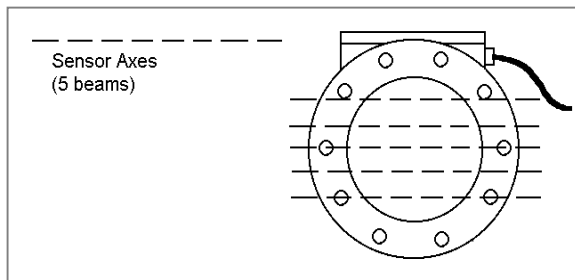

The sensor axis must be approximately horizontal even if the flowmeter is installed in slightly ascending horizontal pipe runs.

The position of the flow sensor in the pipeline shall never be the highest point to avoid gas inclusions. A correct position of the unit guarantees a completely filled flow sensor and accurate flow measurements.

Flow direction

Please note to the forward direction of the flow sensor indicated by the direction arrows on the body. If the flow has this direction the output indication will be positive.

Nuts and bolts

Use the specified bolts and nuts and gaskets, according to the ordered flange type and pressure rating and mount according the general or local requirement.

Vibration

Do not expose the sensor unit to intensive vibrations. Support of the flow sensor is only allowed at the in- and outlet sections near the flow meter.

Gas inclusion

To avoid measuring errors due to gas inclusion, if necessary adequate measures have to be taken to reduce. Gas inclusion shall be limited to the lowest possible value. Gas content shall be < 1% according OIML R117 for accurate measuring.

Particle inclusion

To avoid measuring errors due to particle inclusion, adequate measures have to be taken. Particle inclusion shall be limited to the lowest possible value. Particle content shall be < 1% for accurate measurement.

Inlet and outlet sections

For functioning within stated accuracy the flow sensor has to be installed with specified inlet and outlet sections. The inner diameter of these sections must be equal to the inner diameter of the flanges of the flow sensor. Correct gaskets shall be used. If inlet and outlet sections are ordered they will be used during the calibration and must be installed identically in the final application.

inlet configurations (upstream):

straight inlet section, length 20 D

straight inlet section, length 10 D with flow conditioner / straightening vane

outlet configuration (downstream):

straight outlet section, length 5 D

D = nominal diameter of the flow sensor

Pipe flanges

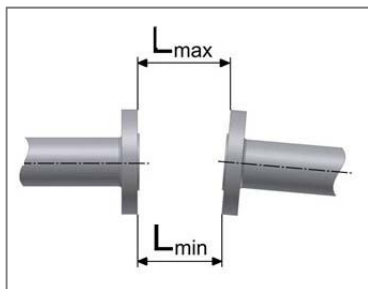

Pipe flange spacing

Refer to dimensional drawings for flange spacing and in addition allow for thickness of gaskets. Install the flow sensor carefully in line with the inlet and outlet sections axis.

Pipe flange faces must be parallel to each other, with a maximum permissible deviation of $L_{\max} - L_{\min} \leq 0.5 \text{ mm (0.02")}$.

2.2 Ultrasonic Flow Converter UFC-V

The converter electronics are mounted in an EEx-d certified casted aluminum explosion proof housing. It contains 3 to 5 ultrasonic flow converters of type UFC 500 / UFC 030. It can also contain a heating device which functions in case of low ambient temperatures. The units inside



are pre-wired. At one side cable glands are mounted. At each corner outside the housing there are mounting brackets for mounting it e.g. on a suitable stable wall.

- After mounting there shall enough space around the housing to open the cover and for the cabling. It is allowed to mount the housing in each position, only avoid situations where water will collect in the cable glands. Provide dripping bends on the cables.
- After the electrical installation, carefully tighten the cover, all bolts shall be used.
- Before closing the cover of the housing, inspect the flame path surface on mechanical damage.
- This surface shall be slightly greased to guaranty protection class IP65 and protection against corrosion. The bolts for fastening the cover shall also be slightly greased also as protection against corrosion. Greasing for instance with silicon grease.
- Unused cable entrances shall be tightened with blind plugs.

Optionally the UFC-V is designed to operate within an ambient temperature of $-40 \dots +60^{\circ}\text{C}$ For use under -20°C ambient temperature the housing is equipped with a heating device to keep the electronics within its working temperature range.

If because of indirect heating e.g. by sunlight the housing temperature can become $> +65^{\circ}\text{C}$ a sunshade is recommended to prevent the electronics inside against excessive heating.

2.3 Ultrasonic Flow Processor UFP-V including I/O rack

The UFP-V Flow Processor has a standard 19" 6U high housing, PC-Based industrial workstation with industrial grade high brightness DSTN LCD display. The workstation may be mounted in a suitable 19" rack. This rack is standard not included. The dimensions of the computer are 482x266x307 mm, mass is about 17 kg, maximum power 260W. Standard this flow computer is equipped with CPU and several I/O boards. One of the boards is KROHNE specific.

For the cable connections, power I/O etc. an I/O rack is supplied, 19" 4U high. The certified unit is containing all terminals for connection to mains and PE (protective earth), the terminals to and/or from auxiliary equipment, I/O-modules and the interface card with the flow processor. Dimensions: 482x176x250 mm, mass 5 kg, 19" 4U, maximum 20W.

Protection class for both items is about IP30. If a higher protection class is required, this can only be attained using a cabinet with the desired IP classification. The cabinet can be equipped with (mechanical) air circulation to prevent overheating the electronics.

3. Electrical installation

3.1 Overview of connections

The figure below shows an overview of the electrical connections of a complete installation. Be aware of the units mounted in the potential explosive hazardous area.

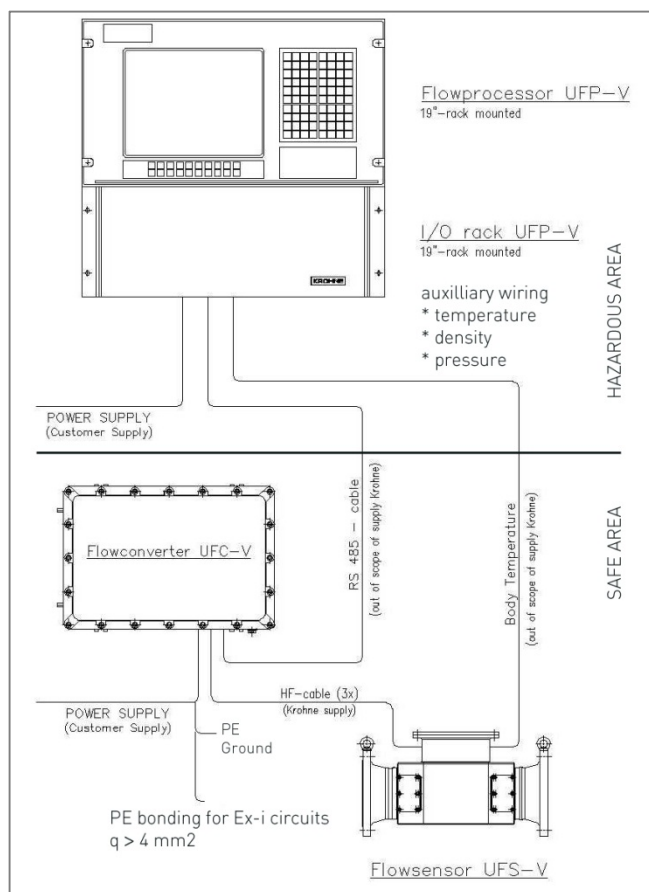

3.2 Installation location and wiring considerations

Cable entries

To conform with protection category requirements, observe the following recommendations:
 Do not kink the cables
 Provide a water drip point (U bend in cable)

Conduits

The described standard version of ALTOSONIC V is equipped with cable glands for the use of harmonized cable. In countries where the electrical codes prescribe conduits, the mounted cable entries shall satisfy the IP protection class, e.g. NEMA 4 or 4X.

Installation and wiring

- When electrical codes require conduits, they must be installed in such a manner that the protection class of the box remains valid. As this equipment is always used in HAZLOC environment (Ex-zone), stopping boxes shall be used.
- Separate conduits shall be used for mains and other wiring.

- It is good practice to use shielded twisted pair solutions for I/O wiring.
- Respect national codes like NEC for the US and CEC for Canada



Grounding

Instrument must be properly grounded to avoid personnel shock hazard!

Please follow local standards and recommendations. The flowmeter must normally be grounded via the protective conductor PE incorporated in the power supply cable. Also an equipotential bonding wire ($\geq 4\text{mm}^2$) between the converter housing and the primary head must be present due to hazardous area regulations. Refer to the supplied electrical wiring figure.

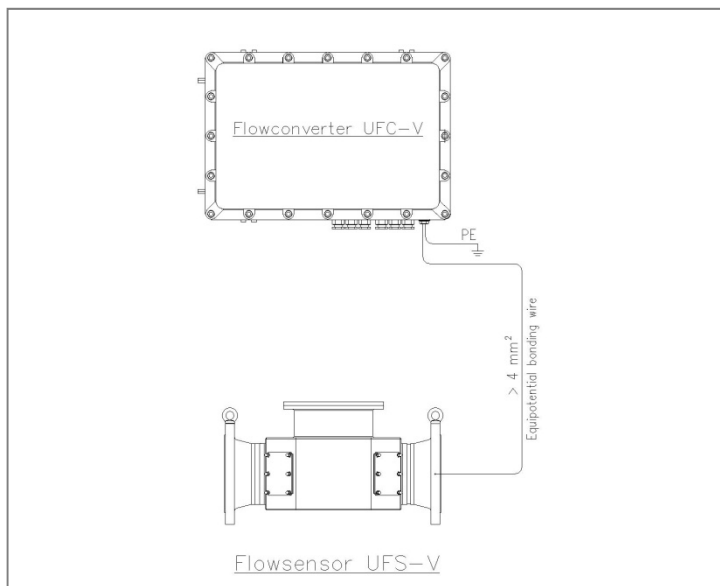

Grounding of Flow Converter UFC-V and Flow Sensor UFS-V

PE

Protective conductor incorporated in power supply cable

Coax

Sensor cables, factory supplied

Bonding wire

Connection cable, cross-section $\geq 4\text{mm}^2$ (10 AGW) Cu, equipped with M6 cable lugs, customer supplied

3.3 Power connection

Note: the information is given on the type plate of the instrument (voltage, frequency etc.)!

Consult the relevant national standard code for electrical installations and for the installation of electrical apparatus in hazardous areas (e.g. particularly VDE0100 and VDE 0165).

All cables leading into the connection box are not intrinsically safe and must be connected in conformity with the relevant approval; please refer to the supplied drawings and hazardous area certificates. The PE/FE protective ground conductor for supply power shall be connected to the PE/FE-terminal in the signal converter housing.

Mains connection of the UFC-V (hazardous environment)

- Use a 3 wire power cable with PE (protective earth conductor) in accordance with the Ex- and possible local regulations.
- The diameter of the power cable has to be in accordance with the nominal diameter of the cable clamp.
- For connection diagram refer to the addition to these instructions or see table below.
- Only the PE conductor (protective earth conductor) shall be connected to the indicated PE terminal in the signal converter housing.

Terminal	Description	Connect to
24V AC/DC (non SELV) 115 / 230V AC		
UFC-V X1 PE	PE	System safety ground
UFC-V X1 N	N	External power supply neutral
UFC-V X1 L	L	External power supply....live
24V AC/DC (SELV)		
UFC-V X1 FE	FE	Not connected
UFC-V X1 -	-	External power supply, neutral
UFC-V X1 +	+	External power supply, live

Mains connection of the UFP-V and the I/O rack (non-hazardous environment)

The mains connection terminals of the UFP-V and the I/O modules on the I/O rack are situated on the back side of the rack. Use a 3 wire power cable with PE (protective earth conductor) in accordance with local regulations. Only the PE conductor (protective earth conductor) shall be connected to the indicated PE terminal in the signal converter housing.

Terminal	Description	Connect to
Mains voltage 115 / 230V AC		
I/O-rack X10b with IEC socket	UFP-V via the IO-rack	UFP-V X10a IEC inlet
UFP-V I/O-rack X1 PE	PE	System safety ground
UFP-V I/O-rack X1 N	N	External power supply neutral
UFP-V I/O-rack X1 L	L	External power supply live

3.4 Connecting Flow Sensor to Flow Converter

The electrical connection between the Flow Sensor and the Flow Converter is by way of factory-supplied sensor signal cables: refer to the connection diagrams. Use pre-certified EEx-d cable glands.

An equipotential bonding shall be made between the UFS-V and the UFC-V. The connection between the Flow Sensor UFS-V and the Flow Converter UFC-V consists of three sensor cables. Each cable contains 4 coaxial cables with preassembled SMB connectors. The cables have to be connected to the Flow Sensor UFS-V through the cable glands to connector X1. All cables are numbered in the same way as the connector X1 is numbered. The cables must run through the special shield connector in such way that the shield is connected to the shield connectors (see picture below).

The shield shall be clamped to the ground rail using the provided connectors. (If applicable, two of the coaxial cables preassembled with SMB connectors are for spare).

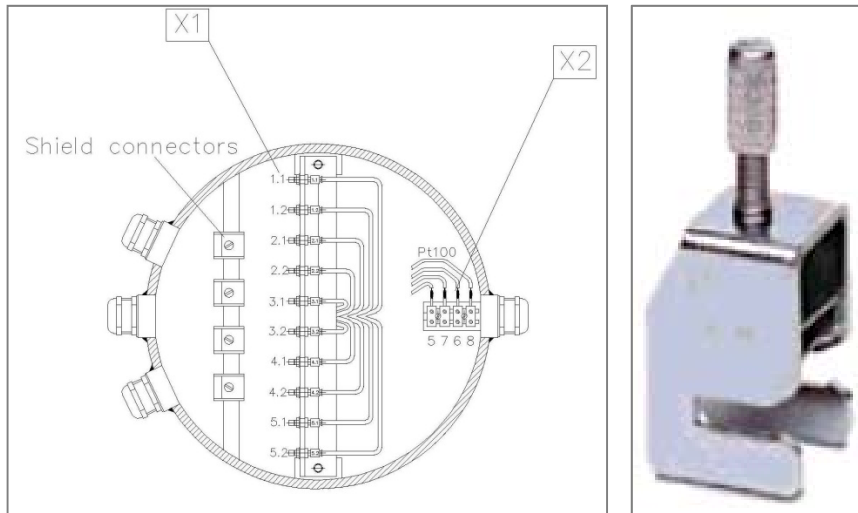

Connection box on Flow Sensor UFS-V and shield grounding clamp

On the side of the Flow Converter UFC-V the cables must be connected in the same way as in the Flow Sensor UFS-V but on connector X2 (see pictures below).

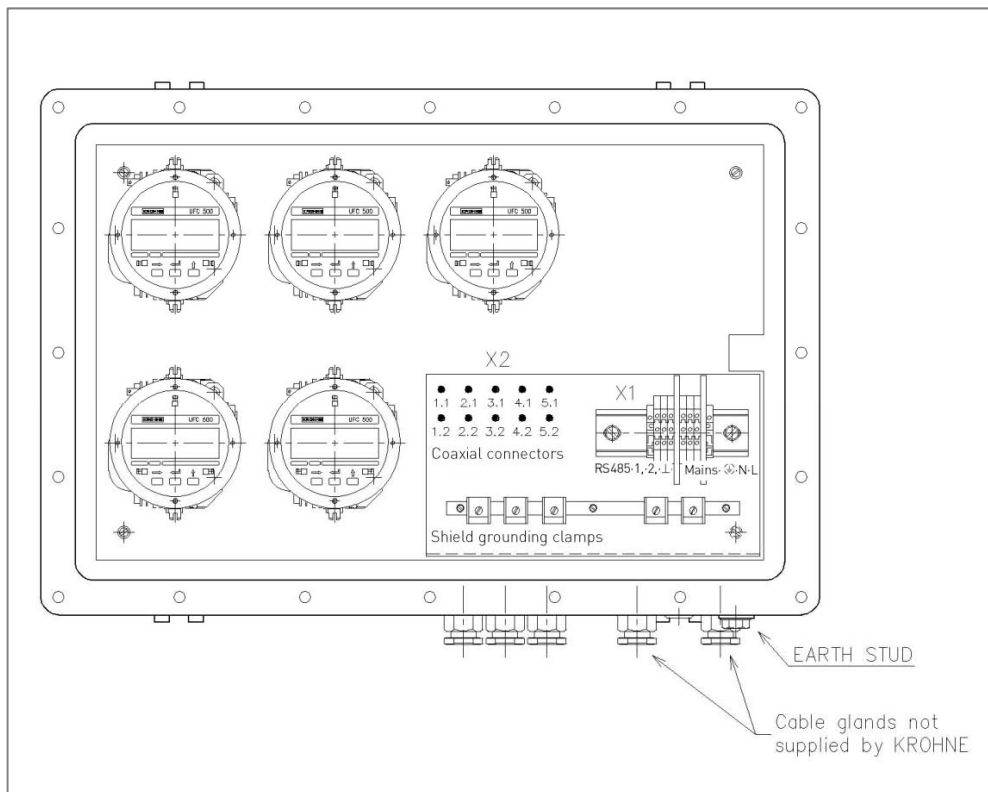

Overview of Flow Converter UFC-V

3.5 Connecting Flow Sensor to the Flow Computer

The Flow Sensor UFS-V also has to be connected to the I/O-rack of the Flow Computer UFP-V. This is the PT100 connection which is connected in the Flow Sensor UFS-V to the PT100 (body temperature) and in the I/O-rack to the MTL5073 module (A1) as shown below. This connection has to be made with a shielded 4-wire cable (not supplied). In the Flow Sensor UFS-V and the I/O-rack (Flow Computer UFP-V) this cable has to be connected in such way that the shield is connected to the shield connectors. The cable has to be connected according to the table below.

Connector X2 UFS-V	Wire	Connector MTL5073 module
5	1	1
7	3	3
6	2	4
8	4	5

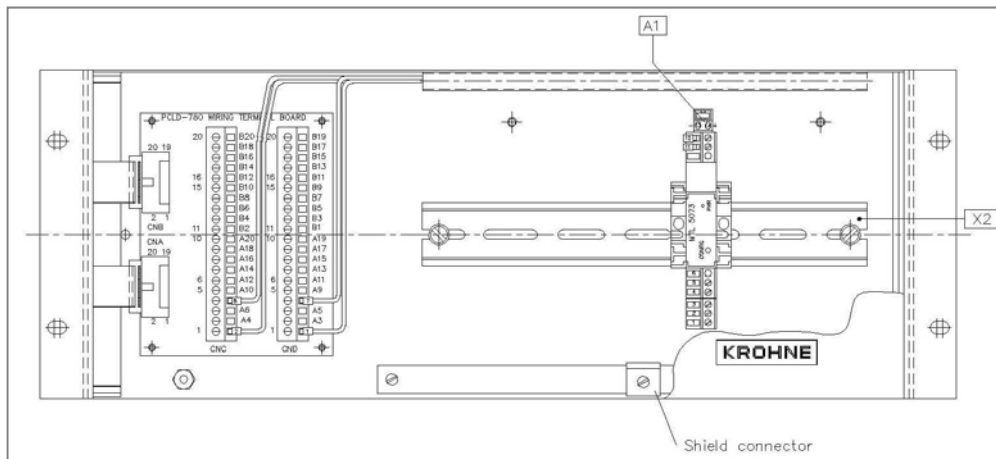

Overview I/O-rack (Flow Computer UFP-V) front side

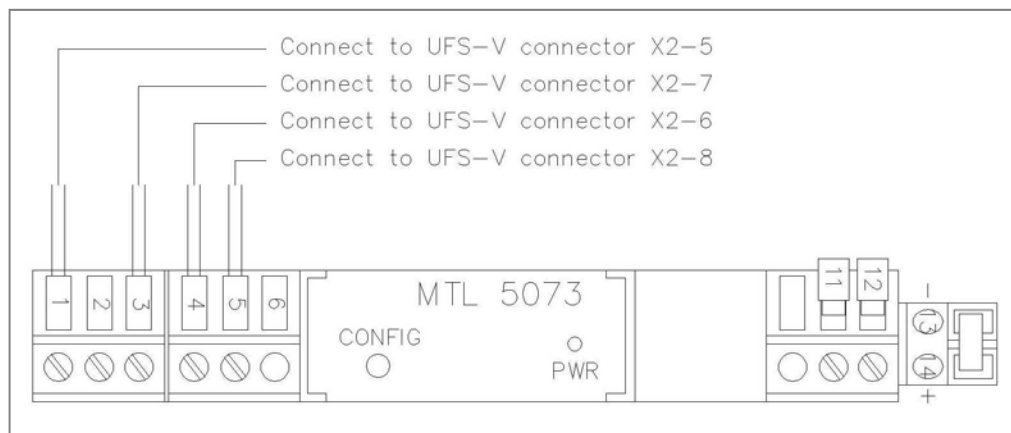

Module A1 (I/O-rack Flow Computer UFP-V)

3.6 Connecting the Flow Converter to the Flow Computer

Between the Flow Converter UFC-V and the I/O-rack (Flow Computer UFP-V) a three wire shielded cable (not supplied) has to be connected. This wire must also be connected with the shield to the shield connectors on both sides. The cable has to be connected according to the table below.

UFC-V X1	Wire	I/O-rack (UFP-V) connection terminal (position number may differ)
-	1	(see connection supplied diagram for position) (-)
+	2	(see connection supplied diagram for position) (+)
⊥	3	(see connection supplied diagram for position) (⊥)

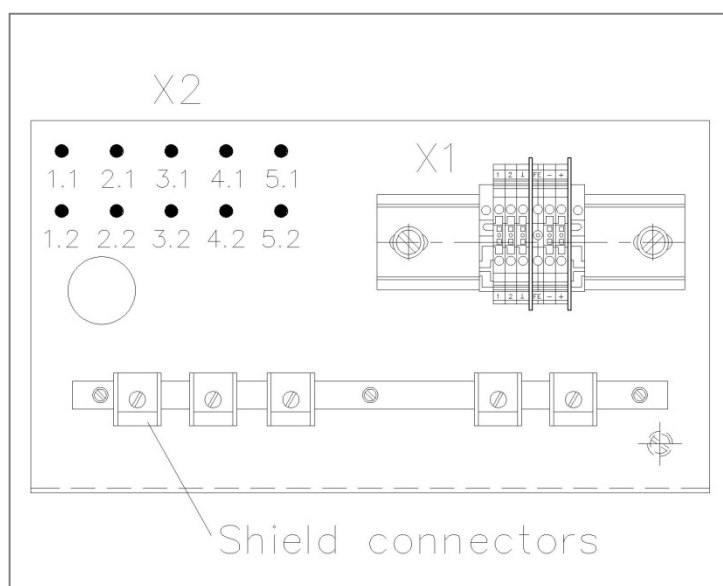

Connector X1 + X2 of Flow Converter UFC-V

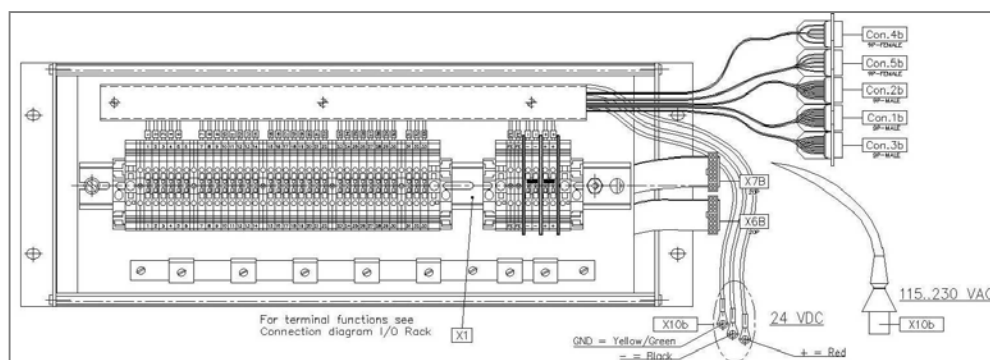

I/O-rack Flow Computer UFP-V rear side (24 VDC version)

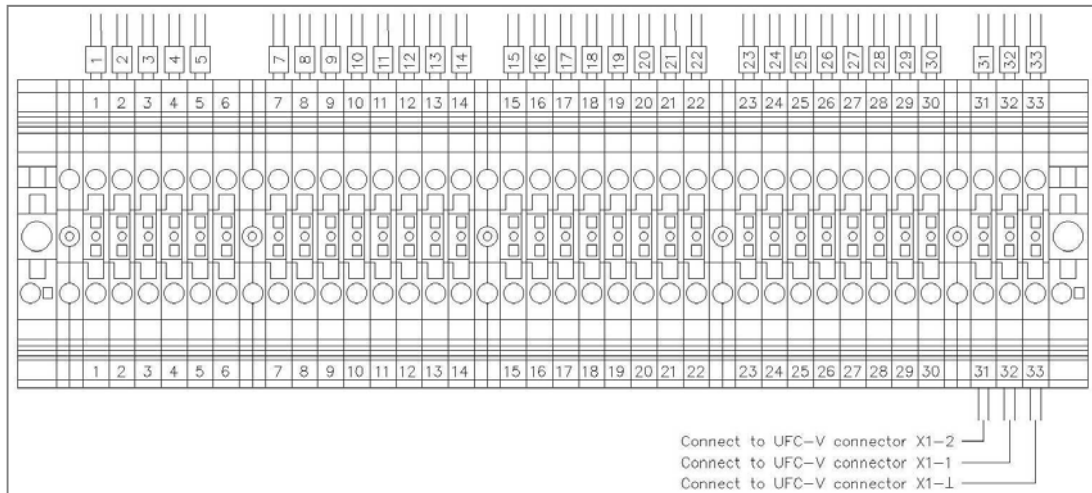

Connector X1 I/O-rack Flow Computer UFP-V



Attention this is an example, position numbers may differ, see connection diagram as delivered with flowmeter!

3.7 Connecting the I/O-rack to the Flow Computer UFP-V

For connecting the Flow Computer UFP-V I/O-rack to the Flow Computer UFP-V the pre-wired connectors on the Flow Computer UFP-V I/O-rack must be used according to the next table.

On Flow Computer UFP-V	Connect Flow Computer UFP-V I/O-rack
CON1A	CON1b
CON2A	CON2b
CON3A	CON3b
CON4A	CON4b
CON5A	CON5b
X6A	X6b
X7A	X7b
X10A	X10b

3.8 Connecting the outputs of the UFP-V I/O-rack

The I/O signals are wired to the connection terminal. This terminal is client specified, therefore only an example can be given.

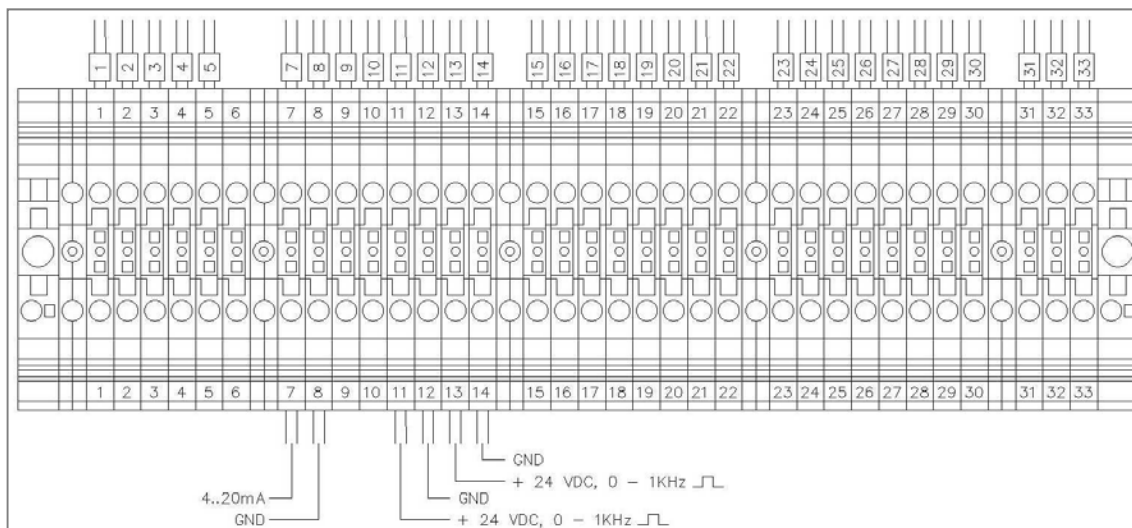

Connector X1 Flow Computer UFP-V I/O-rack

This is an example, position numbers may differ, see connection diagram supplied with flowmeter.



Connection parameters per type for UFP card MP103:

Connection parameter	Card and connector	Limitations
Digital inputs	Mp103 card DB9 Connector 1	TTL compatible U _{max} =12 V I _{min} =1mA I _{max} =10mA
Relay outputs	MP103 card DB9 Connector 2	Switchable: U _{max} =150Vdc, 125Vac I _{max} =0.2A
Current output	MP103 card DB9 Connector 3	Active(0..22mA): R load < 500 Ohm Passive : U _{ext} = 8.1...30V R load = (U _{ext} - 8V) / 22mA I = 0..22mA
Pulse outputs	MP103 card DB9 Connector 3	Selectable by jumper setting on MP103 card 24V : I _{max-out} = 10mA, R _i =2k4 12V : I _{max-out} = 5mA , R _i =2k4 Open Collector: U _{min} = 1V, I _{max} =10mA
Pulse Power	MP103 card DB9 Connector 3	Only for use in Internal Pulse circuit (external 2k2 resistors to activate passive pulse outputs)
Frequency inputs	MP103 card DB9 Connector 6	Open Collector: U _{max} =5V, I _{sink} = 5mA Usually connected through barrier

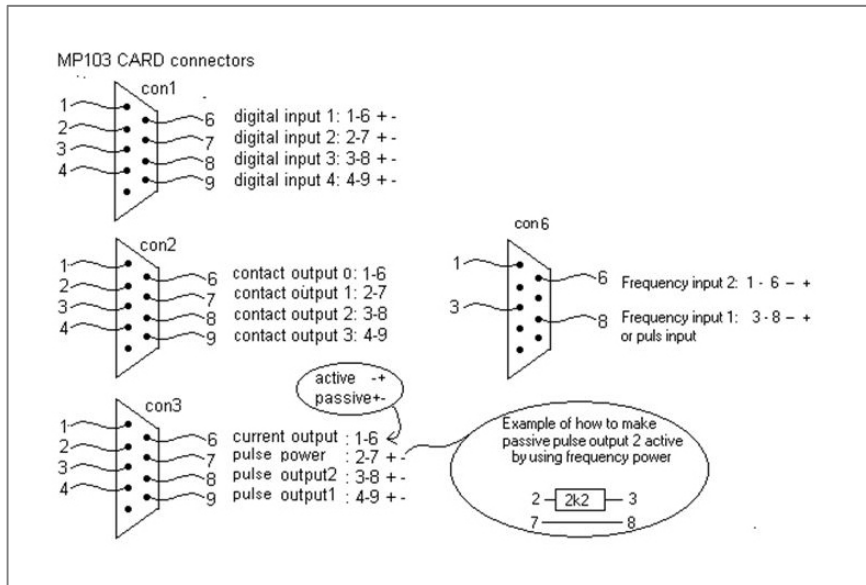

Connection parameters per type for UFP card MP103

Analog inputs	AD812 card PCLD 780 wiring board	Pmax (limit for used 250 ohm resistors) = 0.2 W Maximum Overvoltage continuous = +/- 7V Usually connected through barriers
Analog outputs	AD812 card PCLD 780 wiring board	Maximum Output drive = 5mA , 10V max Normally connected through barrier converters(0..10V :: 4-20mA)

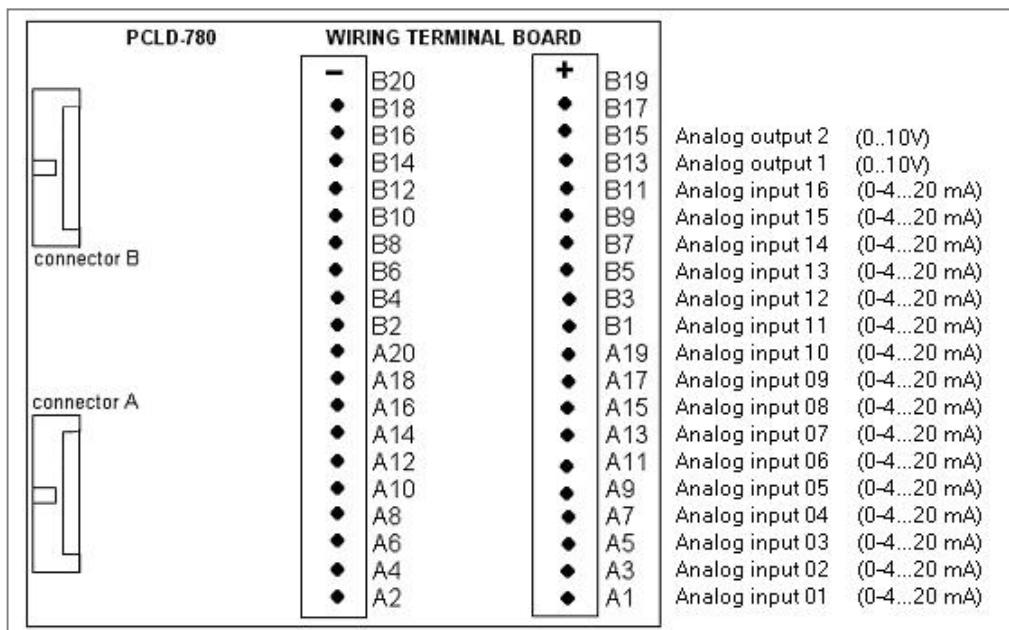

3.9 Computer and I/O rack

The custody certified Flow Processor UFP-V and I/O rack are used to process the input flow data from the UFS-V, UFC-V flow meter and the auxiliary apparatus like temperature, pressure and density measuring instruments. The results are displayed on the screen and represented in a train of output pulses with a calibrated one pulse volume¹. Data exchange and control to external computers (e.g. PLCs) is also possible by Modbus connection). The functions are described in the Modbus operating instructions.

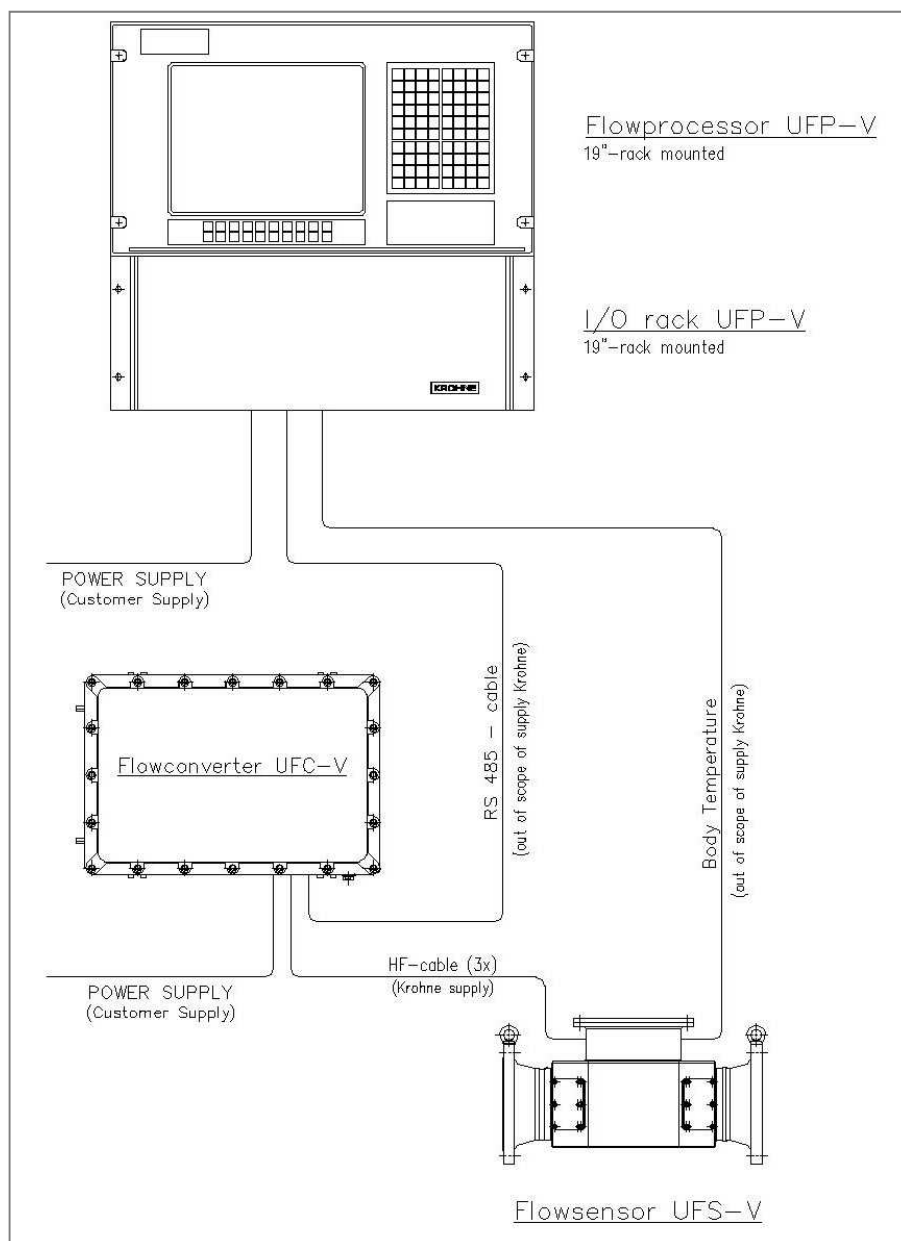

¹ One pulse volume = $\frac{1}{K} = \frac{V}{n}$ (26), NEN EN ISO 4267-2 : 1988(E)

Construction

The Flow Processor UFP-V, is an industrial type computer, e.g. Advantec Workstation AWS-842T. The I/O modules are mounted on the front side of the I/O-rack and transfer the (intrinsically safe) process inputs to the flow processor. On the back side are the connections to the UFC-V field mounted converter unit, the custody transfer certified pulse output, the Modbus connection, as well as binary status outputs and control inputs. For custody transfer purposes the panel may be sealed. The optional printer connection is direct on the terminal of the workstation and is supplied with a DB9 connector. See figure for terminal side of the workstation).

I/O rack input signals (front side)

The I/O modules are interfacing with process instruments for:

- Temperature, Pt100 or 4...20 mA transmitters;
- Pressure 4...20 mA transmitters
- Density transmitters with frequency superposed on the loop current.

Note: Modules may be intrinsically or non-intrinsically safe.

Custody transfer certified I/O modules that may be used are:

- Made by MTL (Cenelec, FM and CSA Ex i certified modules)
 - MTL 5073/4 Pt 100 temperature input
 - MTL 7206 4 .. 20 mA loop powered transmitters
 - MTL 7087 4 .. 20 mA loop powered density transmitters
- Made by Phoenix (for non Ex circuits)
 - MCR-T-UI Pt 100 temperature input
 - MCR-CPS-I/I-44-E 4 .. 20 mA loop powered transmitters
- Made by Pepperl & Fuchs
 - KFD2-CD-Ex1.32-8 4 .. 20 mA current output
 - Module by KROHNE

Data sheets of the different modules are not included because it is dependent of the ordered configuration. Connections are not renumbered so the data sheets of the modules and the equipment connected are needed for the planning of the installation.

Connection of the body temperature sensor of the UFS-V to the I/O module

Because the flow sensor UFS-V is mounted in a potential hazardous area an Ex-i certified I/O interfacing module MTL 5073/4 for the body temperature shall be used. The body temperature sensor terminals are interfaced as follows:

MTL 5073/4 connection terminals	UFS-V Pt 100 connection terminals
1	5
4	7
3	6
5	8

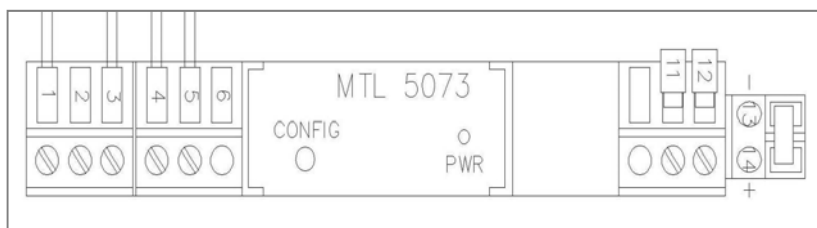

Top view I/O module MTL 5073

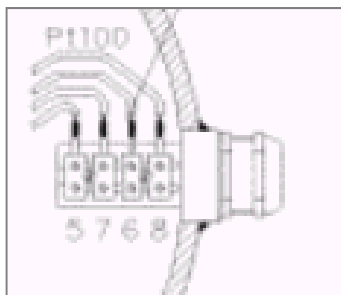

UFS-V junction box detail

Field cabling

For the different signals twisted shielded pairs shall be used. The shielding shall be connected to the ground rail with the provided clamps. Grounding of the shielding is part of the CE conformity, as well as of the conformity with the OIML test report. Minimum wire size 0.5mm² loop resistance has to be respected and wire cross section chosen to fit.

The field cabling shall be according to the local regulations and practice. The instrument is constructed in accordance with the applicable European directives. LVD 73/23/EEC, EMC 89/336/EEC, ATEX 94/9/EC (ATEX 100a). The units are only for installation in non-hazardous areas. The modules may be cabled into hazardous locations this cabling shall be according to EN IEC 600079-14 installation standard and in this case the modulus shall be ordered accordingly. For modules cabled onto a non-hazardous area standard installation requirements apply. Respect the local standards.

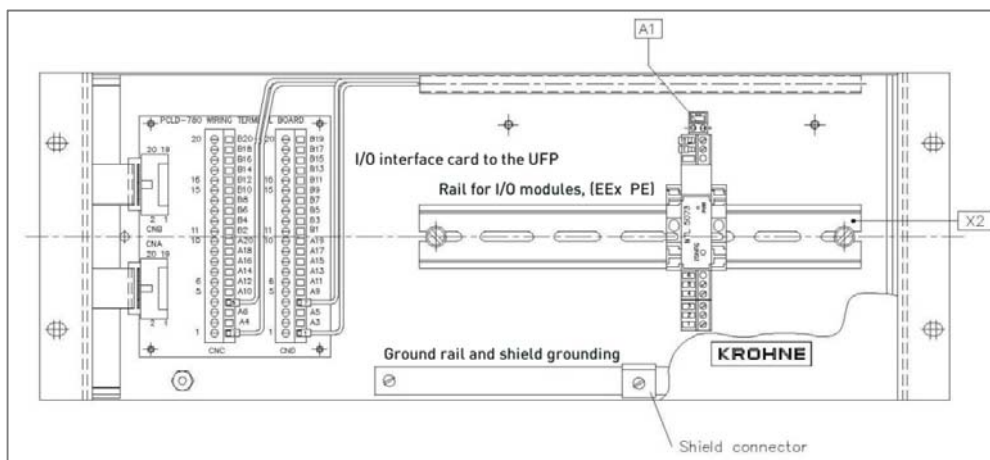

Front side of I/O rack with a body temperature unit

Example of a configuration with interfacing modules (front side)

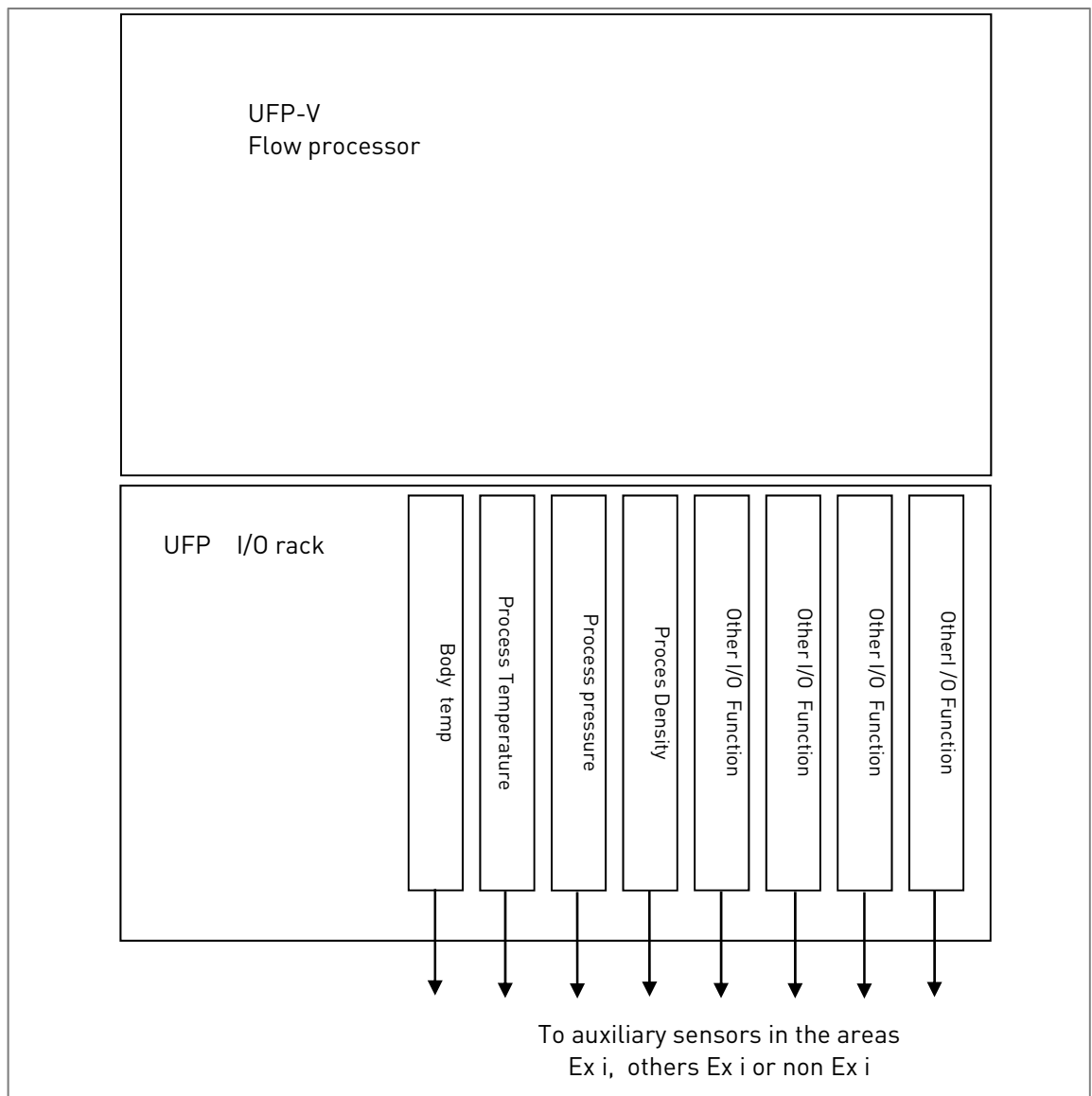

Connections terminals at the rear of the I/O rack

At the back side of the I/O rack are mounted the connection terminals for mains and the I/O communication to external apparatus see figure x. In the table below you can find the detailed list of the terminal numbers and its function.

Further detailed information of the functions refer to the operating manual.

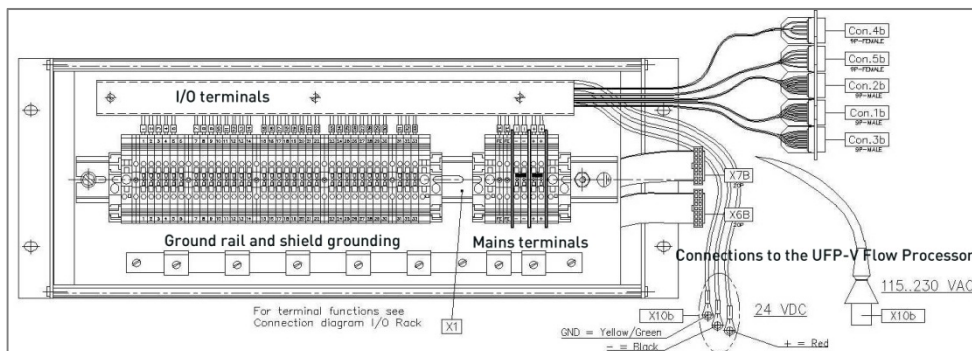

Rear of the I/O rack

Items marked with connections to the UFP-V Flow Processor are pre-wired. It concerns power inlet and the I/O communication. Connect these connectors in the prescribed way to the flow processor. In the table below the signals and their respective connections are listed preset on the terminals on the terminals at the back side of the I/O rack.

Terminal No.		Function / Description	
+	-	If applicable pos. or neg. signal level	
1		TX-	Modbus RS422/RS485 data comm.
2		TX+	
3		RX-	
4		RX+	
5		Return	
6		NC	
7	8	4...20 mA current output (e.g. actual flow)	
9	10	Power for pulse outputs if passive output must be activated externally	
11	12	Pulse output 1	
13	14	Pulse output 2	
15	16	Reset totalizers	
17	18	Reset alarms	
19	20	Start calibration	For factory use only
21	22	Stop calibration	
23	24	Failure signal output	
25	26	Warning signal output	
27	28	Forward flow direction > low flow cut-off forward	
29	30	Reverse flow direction > low flow cut-off reverse	
31		A	RS485 flow data from UFC-V to UFP-V
32		B	
33		Return	
PE		Safety grounding	Mains 115 / 230 VAC - 50-60Hz
PE			
N		Neutral	
N			
L		Phase	
L			

For the connections to PLC's and other equipment used in the installation, shielded cables shall be used and the shielding shall be connected to the ground rail using the provided shield grounding clamps. These shields are part of the CE conformity. Not respecting these rules may lead to EMC problems. If grounding is prohibited according to other rules or regulations a capacitor shall be used to get a HF bounding of the shields (capacitor not included with supply).



The electrical safety grounding shall be provided on the green yellow colored connection terminal, marked with PE. Local installation regulations and general practice shall be respected

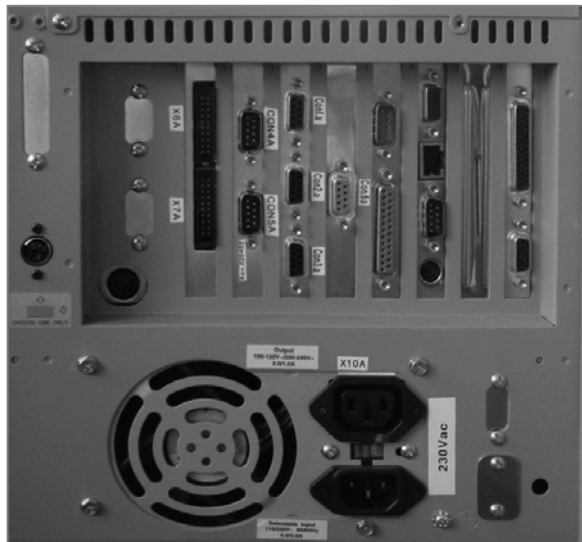

Side view Advantec Workstation AWS-842T

3.10 Modbus connection/communication to external equipment

The UFP-V Flow Processor is equipped with a RS 485/RS422 communication card which provides two serial communication channels. The first channel is used for the communication with the UFC-V Flow Converter unit and is factory set. The second channel is defined for Modbus communication with external systems. Flow data and relevant auxiliary signals are available. A user configurable Modbus I/O channel is available to interface with external host or slave systems. For more detailed information settings and operating reference to the ALTOSONIC V Modbus Manual. The Modbus connection terminals are available at the backside of the I/O rack marked with numbers 1, 2, 3, 4 and 5.

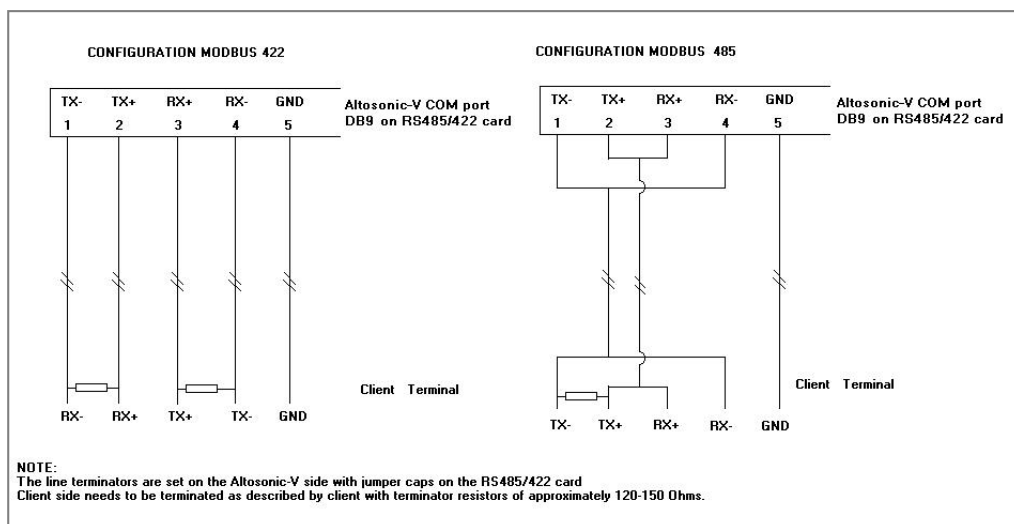

External wiring UFP card PCL745 for Modbus

4. Returning the flowmeter for service or repair

Your ultrasonic flowmeter has been carefully manufactured and tested by a company with ISO 9001 certification and volumetrically calibrated in one of the world's most accurate test rigs.

If installed and operated in accordance with the operating instructions, your flowmeter will rarely present any problems. Should you nevertheless need to return a flowmeter for checking or repair, please pay attention to the following:

Due to statutory regulations concerning protection of the environment and the health and safety of our personnel, KROHNE will only handle, test and repair returned flow meters that have been in contact with liquids without risk to personnel and environment or that have been properly cleaned from such liquids. KROHNE will only service your flow meter if it is accompanied by a statement in line with the following model confirming that the flow meter is safe to handle.

If the flowmeter has been operated with toxic, caustic, flammable or water polluting liquids, you are kindly requested:

To check and ensure, if necessary by rinsing or neutralizing, that all cavities in the flowmeter are free from dangerous substances.

To enclose a statement with the flow meter confirming that the flow meter is safe to handle and stating the liquid used. KROHNE regrets that they cannot service your flow meter unless accompanied with such a statement.

4.1 Specimen statement:

Company:
Department:
Address:
Name:
Tel. No.

Details enclosed flowmeter:

Type:
KROHNE Order No.

Has been operated with the following liquid:

Because the liquid is:

water-pollutant toxic caustic flammable (tick where applicable)

We have checked that the flowmeter and all cavities in the flowmeter are

free from such substances flushed out* and neutralized.

* delete where not applicable

We confirm that there is no risk to man or environment through any residual liquid in or on the flow meter or in any of its cavities.

Date:
Signature: Company Stamp:

4.2 Spare parts

For more information please contact KROHNE!



KROHNE product overview

- Electromagnetic flowmeters
- Variable area flowmeters
- Ultrasonic flowmeters
- Mass flowmeters
- Vortex flowmeters
- Flow controllers
- Level meters
- Temperature meters
- Pressure meters
- Analysis products
- Measuring systems for the oil and gas industry
- Measuring systems for sea-going tankers

Head Office KROHNE Messtechnik GmbH
Ludwig-Krohne-Str. 5
D-47058 Duisburg (Germany)
Tel.: +49 (0)203 301 0
Fax: +49 (0)203 301 10389
info@krohne.de

The current list of all KROHNE contacts and addresses can be found at:
www.krohne.com

KROHNE