



H250 M40 Supplementary instructions

Equipment category II 3G, EPL Gc
in protection type non-sparking Ex-nA



1	Safety instructions	3
<hr/>		
1.1	General notes	3
1.2	EC conformity	3
1.3	Approval according to the IECEx scheme	3
1.4	Security information	3
2	Device description	4
<hr/>		
2.1	Device description	4
2.2	Description code	4
2.3	Marking	5
2.4	Flammable products	6
2.5	Equipment category	6
2.6	Protection types	7
2.7	Ambient temperature / temperature classes	8
2.8	Electrical data	14
3	Installation	15
<hr/>		
3.1	Installation	15
4	Electrical connections	16
<hr/>		
4.1	General notes	16
4.2	Power supply	16
4.3	Inputs/outputs	16
4.4	Grounding and equipotential bonding	17
5	Operation	18
<hr/>		
5.1	Start-up	18
5.2	Operation	18
5.3	Electrostatic charge	18
6	Service	19
<hr/>		
6.1	Maintenance	19
6.2	Dismantling	19

1.1 General notes

These additional instructions apply to explosion-protected versions of variable area flowmeters with electrical built-ins and the marking II 3 G. They complete the installation and operation instructions for the non-explosion protected versions.

The information given in these instructions contains only the data relevant to category 3 explosion protection. The technical details given in the installation and operation instructions for the non-explosion protected versions apply unchanged unless excluded or superseded by these Instructions.

1.2 EC conformity

The manufacturer declares with the EC declaration of conformity, in which the applied standard is also specified, on his own responsibility conformity with the protection goals of directive 94/9/EC for use in hazardous areas with gas and dust.

The EC declaration of conformity for the equipment category II 2 G and II 2 D is based on the EC type examination certificate of the Physikalisch Technische Bundesanstalt (PTB):

PTB 11 ATEX 2012 X

The "X" after the certificate number refers to special conditions for safe use of the device, which have been listed in these instructions.

If needed the EC type examination certificate can be downloaded from the manufacturer's website.

1.3 Approval according to the IECEx scheme

Conformity with IECEx standards was tested in accordance with the IECEx Certification Scheme for Explosive Atmospheres acc. to IEC 60079-0 and IEC 60079-15. The number of the IEC certificate is:

IECEx PTB 11. 0069 X

The "X" after the certificate number refers to special conditions for safe use of the device, which have been listed in these Instructions.

The EC type test certificate may be downloaded from the manufacturer's website as needed.

1.4 Security information

Assembly, installation, start-up and maintenance may only be performed by personnel trained in explosion protection!



CAUTION!

The operator respectively his agent is responsible to follow further standards, directives or laws if required due to operating conditions or place of installation. This applies particularly for the use of easy detachable process connections such as SMS or Clamp when measuring flammable mediums.

2.1 Device description

Variable area flowmeters measure and display the volume flow of flammable and non-flammable gases and liquids. Depending on the device version, electrical limit switch contacts, a 4...20 mA signal output with

HART® communication, a Foundation Fieldbus interface or a Profibus PA interface can be installed in the indication unit.

2.2 Description code

The safety description code * consists of the following elements:

H	2	5	0	/		/		/	M	4	0	/		/		/		-	E	x	-			
①					②				③				④									⑧		⑨

- ① Type series measuring unit H250
H250 - standard version, vertical upwards
H250H - horizontal orientation
H250U - vertical downwards
- ② Measuring unit materials / versions
RR - Stainless Steel
C - PTFE or PTFE/ceramics
HC - Hastelloy C
Ti - Titanium
F - Food
- ③ Heating jacket version
blanc - without heating jacket
B - with heating jacket
- ④ Signal converter version
M40 - Aluminium housing, painted (standard)
M40S - Aluminium housing with increased corrosion protection
M40R - Stainless steel housing
- ⑤ High temperature version
blanc - without HT extension
HT - with HT extension
- ⑥ Electrical signal output
blanc - without transmitter
ESK - Electrical signal output 4...20mA (ESK4)
... - optionally available with counter, I/O module and display (ESK4-T) or
... - Foundation Fieldbus (ESK4-FF) or
... - Profibus PA (ESK4-PA)
- ⑦ Limit switches
blanc - without limit switches
K1 - One limit switch
K2 - Two limit switches
R1 - 1 reed switch
R2 - 2 reed switches
- ⑧ Version
Ex - Explosion-protected version
- ⑨ SIL Version
SE - SIL compliant electronic signal output
SK - SIL compliant limit switch

* positions which are not needed are omitted (no blank positions)

2.3 Marking

Type designation of the complete unit is shown on the indicator with the nameplates reproduced below (see also description code).

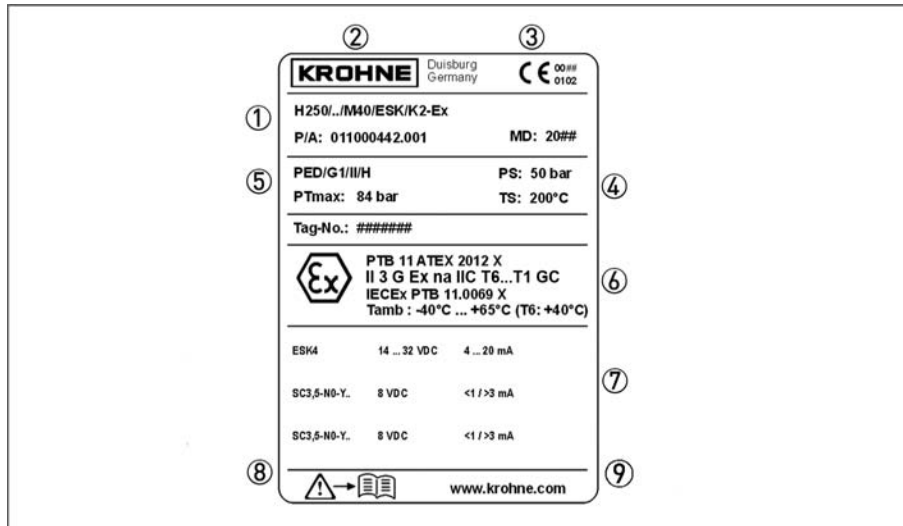

Figure 2-1: Example of a rating plate

- ① Device type
- ② Manufacturer
- ③ ATEX & DGRL certification agency code.
- ④ Sizing data: temperature & pressure rating
- ⑤ PED data
- ⑥ Ex data
- ⑦ Electrical connection data
- ⑧ Note on observing documentation
- ⑨ Manufacturer's website

Additional markings on the housing cover:

- SN - serial number
- SO - sales order / item
- PA - order
- Vxxx - product configurator code
- AC - article code

Additional plate

The association of the housing cover to the device is confirmed by an additional plate with the serial number on the interior of the indicator part.

2.4 Flammable products

Atmospheric conditions:

An explosive atmosphere is a mixture of air and flammable gases, vapours, mists or dusts under atmospheric conditions. It is defined by the following values $T_{\text{atm}} = -20\dots+60^{\circ}\text{C}$ / $-4\dots+140^{\circ}\text{F}$ and $P_{\text{atm}} = 0.8\dots1.1$ bar. Outside of this range, for most mixtures no key figures are available for the ignition behaviour.

Operating conditions:

Variable area flowmeters operate outside of atmospheric conditions, which means that explosion protection according to directive 94/9/EC (ATEX) – regardless of the zone assignment – is fundamentally not applicable due to the lack of key safety data for the interior of the measuring section.



WARNING!

Operation with flammable products is only permitted as long as no explosive fuel/air mixture builds up on the inside of the flowmeter under operating conditions. The operator is responsible to ensure that the flowmeter is operated safely in terms of the temperature and pressure of the products used. In case of operation with flammable products the measuring units must be included in the periodic pressure tests of the system. When using the device version H250/C... (PTFE-liner, nonconductive) the min. conductivity of the medium must be 10^{-8} S/m, in order to avoid the electrostatic charge.

2.5 Equipment category

Variable area flowmeters are designed in accordance with EN 60079-0 and EN 60079-15 in Category II 3 G or EPL Gc designed for use in zone 2. The inside of the measuring unit is also permitted for zone 2.



INFORMATION!

Definition of zone 2 acc. to EN 1127-1, Appendix B:

An area in which an explosive atmosphere as a result of the mixture of flammable substances in the form of gas, steam or mist with air is not expected to occur under normal operation. If, however, such an atmosphere does occur it only lasts for a brief period of time.

2.6 Protection types

The variable area flowmeter is designed in protection type "non-sparking" according to EN 60079-15. Explosion protection is ensured by the absence of sparking contacts and hot surfaces during normal operation.

The marking is: **II 3G Ex nA IIC T6...T1 Gc** or **II 3G Ex nA IIB T6...T1 Gc**

The marking contains the following information:	
II	Group II explosion protection
3	Equipment category 3
G	Gas explosion protection
Ex nA	Non-sparking equipment
IIC	Gas group, Suitable for gas groups IIC, IIB and IIA
IIB	Gas group, Suitable for gas groups IIB and IIA
T6...T1	Temperature class, suitable for temperature classes T6 ... T1
Gc	EPL, suitable for zone 2

2.7 Ambient temperature / temperature classes

Due to the influence of the product temperature, variable area flowmeters with built-in electrical equipment (electric variants) are not assigned to any fixed temperature class. The temperature class of these devices is rather a function of the product temperature and ambient temperature that is present and the specific device version. The classification is outlined in the following tables.

The tables take into account the following parameters:

- Installed equipment
- Ambient temperature T_{amb} .
- Product temperature T_m
- Nominal DN
- Standard or high temperature version (HT)
- Standard or heating jacket version
- Heat resistance of the connecting cable

When there is more than type of built-in equipment, the data of the most unfavourable equipment should be used.



INFORMATION!

The maximum permissible product temperatures listed in the tables are valid under the following conditions:

- *The measuring device is installed and operated in accordance with the manufacturer's installation instructions.*
- *It must be ensured that the flowmeter is not heated by the effects of additional heat radiation (sunshine, neighbouring system components) and thus operated above the permissible ambient temperature range.*
- *Insulation must be limited to the piping. Unobstructed ventilation of the indicator part must be ensured. To do this, the variant with a projecting indicator (HT version) is preferable.*
- *For device versions with a heating jacket, that the temperature of the heating medium does not exceed the maximum permissible product temperature.*

For certain device version, lower values apply due to differing boundary conditions (e.g. lining materials). Here the user should consult the technical data sheet.

Using a heat resistant connecting cable

Temperature table in °C					
Heating jacket			T _m ①		
without	with	HT-version	T _{amb} ≤ 40	T _{amb} ≤ 60	T _{amb} ≤ 65
DN15, DN25, DN50	DN15, DN25		220	105	75
		x	-	175	95
DN80, DN100	DN50, DN80		165	90	75
		x	-	155	90

Temperature table in °F					
Heating jacket			T _m ①		
without	with	HT-version	T _{amb} ≤ 104	T _{amb} ≤ 140	T _{amb} ≤ 149
DN15, DN25, DN50	DN15, DN25		428	221	167
		x	-	347	203
DN80, DN100	DN50, DN80		329	194	167
		x	-	311	194

① Maximum value of the product temperature for the use of a standard connecting cable. For higher product temperatures a connecting cable with a temperature resistance of 90°C / 194°F is required.

HT version - high-temperature version with projecting indicator

The permitted ambient temperature range is indicated on the nameplate; depending on the device version it is T_{amb} = -40...+65°C / -40...+149°F or T_{amb} = -25...+65°C / -13...+149°F.

The minimum product temperature is -40°C / -40°F.

Maximum permitted product temperature in °C

				Maximum permitted product temperature T_m [°C]										
Heating jacket			TK ▶	T6	T5		T4		T3			T2, T1		
None	with	HT version	T_{amb} [°C] ▶	≤ 40	≤ 60	≤ 65	≤ 60	≤ 65	≤ 40	≤ 60	≤ 65	≤ 40	≤ 60	≤ 65
ESK4														
DN15	DN15			85	100	90	135	135	200	160	140	235	160	140
DN25	DN25	x		85	100	100	135	135	200	200	200	300	300	270
DN50														
DN80	DN50			85	100	85	135	130	200	150	130	220	150	130
DN100	DN80	x		85	100	100	135	135	200	200	200	300	300	255
ESK4-T														
DN15	DN15			85	90	70	135	120	200	140	120	220	140	120
DN25	DN25	x		85	100	85	135	135	200	200	200	300	290	225
DN50														
DN80	DN50			85	85	70	130	115	200	130	115	200	130	115
DN100	DN80	x		85	100	80	135	135	200	200	200	300	270	215
ESK4-FF / ESK4-PA														
DN15	DN15			70	60	not admissible	135	125	200	150	125	235	150	125
DN25	DN25	x		85	60		135	135	200	200	200	300	300	240
DN50														
DN80	DN50			65	60		135	120	200	140	120	220	140	120
DN100	DN80	x		85	60		135	135	200	200	200	300	300	225
K1/K2														
DN15	DN15			85	100	100	135	135	200	200	180	290	205	180
DN25	DN25	x		85	100	100	135	135	200	200	200	300	300	300
DN50														
DN80	DN50			85	100	100	135	135	200	185	170	260	185	170
DN100	DN80	x		85	100	100	135	135	200	200	200	300	300	300

Maximum permitted product temperature in °F

				Maximum permitted product temperature T_m [°F]										
Heating jacket			TK ▶	T6	T5		T4		T3			T2, T1		
None	with	HT version	T_{amb} [°F] ▶	≤ 104	≤ 140	≤ 149	≤ 140	≤ 149	≤ 104	≤ 140	≤ 149	≤ 104	≤ 140	≤ 149
ESK4														
DN15	DN15			185	212	194	275	275	392	320	284	455	320	284
DN25	DN25	x		185	212	212	275	275	392	392	392	572	572	518
DN50														
DN80	DN50			185	212	185	275	266	392	302	266	428	302	266
DN100	DN80	x		185	212	212	275	275	392	392	392	572	572	491
ESK4-T														
DN15	DN15			185	194	158	275	248	392	284	248	428	284	248
DN25	DN25	x		185	212	185	275	275	392	392	392	572	554	437
DN50														
DN80	DN50			185	185	158	266	239	392	266	239	392	266	239
DN100	DN80	x		185	212	176	275	275	392	392	392	572	518	419
ESK4-FF / ESK4-PA														
DN15	DN15			158	140	not admissi ble	275	257	392	302	257	455	302	257
DN25	DN25	x		185	140		275	275	392	392	392	572	572	464
DN50														
DN80	DN50			149	140		275	248	392	284	248	428	284	248
DN100	DN80	x		185	140		275	275	392	392	392	572	572	437
K1/K2														
DN15	DN15			185	212	212	275	275	392	392	356	554	401	356
DN25	DN25	x		185	212	212	275	275	392	392	392	572	572	572
DN50														
DN80	DN50			185	212	212	275	275	392	365	338	500	365	338
DN100	DN80	x		185	212	212	275	275	392	392	392	572	572	572

Maximum permitted product temperatures for painted measuring units in °C

Heating jacket			TK ▶	Maximum permitted product temperature T_m [°C]				
None	with	HT version	T_{amb} [°C] ▶	T6	T5		T4 ... T1	
DN15... DN100	DN15... DN80	With / none		≤ 40	≤ 60	≤ 65	≤ 60	≤ 65
ESK4 / ESK4-T				40	65	65	65	65
ESK4-FF / ESK4-PA				40	60	not admissible	65	65
K1/K2				40	65	65	65	65

Maximum permitted product temperatures for painted measuring units in °F

Heating jacket			TK ▶	Maximum permitted product temperature T_m [°F]				
None	with	HT version	T_{amb} [°F] ▶	T6	T5		T4 ... T1	
DN15... DN100	DN15... DN80	With / none		≤ 104	≤ 140	≤ 149	≤ 140	≤ 149
ESK4 / ESK4-T				104	149	149	149	149
ESK4-FF / ESK4-PA				104	140	not admissible	149	149
K1/K2				104	149	149	149	149

Reference point consideration

The permissible product and ambient temperatures may be exceeded or undershot as long as the permissible temperature range of the reference point of the display is not exceeded. The following table contains the permissible maximum values at the reference point. Note:

- Reference point is the connection of the equipotential bonding conductor of the M40 indicator.
- The temperatures at the reference point are to be determined in the most unfavourable operating situation.
- The required measuring uncertainty is max. 2K.
- Measuring conditions and results are to be permanently recorded in a suitable format.
- The measuring unit should be insulated properly.

Maximum permitted temperatures at reference point of indicator in °C

Design of indicator	Component	Permitted temperature range at reference point T [°C] according to temperature class			
		TK ▶	T6	T5	T4 ... T1
M40./../K.	SC3,5-NO-Y		-20 ... +65	-20 ... +80	-20 ... +90
	SJ3,5-SN		-20 ... +66	-20 ... +81	-20 ... +90
	SJ3,5-S1N		-20 ... +66	-20 ... +81	-20 ... +90
	I7S23,5-N		-40 ... +70	-40 ... +85	-40 ... +90
M40./../ESK4/K.	SC3,5-NO-Y		-20 ... +55	-20 ... +70	-20 ... +80
	SJ3,5-SN		-20 ... +55	-20 ... +70	-20 ... +80
	SJ3,5-S1N		-20 ... +55	-20 ... +70	-20 ... +80
	I7S23,5-N		-40 ... +55	-40 ... +70	-40 ... +80
M40./../ESK4	ESK4		-40 ... +55	-40 ... +70	-40 ... +80
M40./../ESK4-T	ESK4 and I/O modul		-40 ... +52	-40 ... +67	-40 ... +77
M40./../ESK4-FF	ESK4 and ESK4-FF		-40 ... +36	-40 ... +51	-40 ... +76
M40./../ESK4-PA	ESK4 and ESK4-PA				

Maximum permitted temperatures at reference point of indicator in °F

Design of indicator	Component	Permitted temperature range at reference point T [°F] according to temperature class			
		TK ▶	T6	T5	T4 ... T1
M40./../K.	SC3,5-NO-Y		-4 ... +149	-4 ... +176	-4 ... +194
	SJ3,5-SN		-4 ... +151	-4 ... +178	-4 ... +194
	SJ3,5-S1N		-4 ... +151	-4 ... +178	-4 ... +194
	I7S23,5-N		-40 ... +158	-40 ... +185	-40 ... +194
M40./../ESK4/K.	SC3,5-NO-Y		-4 ... +131	-4 ... +158	-4 ... +176
	SJ3,5-SN		-4 ... +131	-4 ... +158	-4 ... +176
	SJ3,5-S1N		-4 ... +131	-4 ... +158	-4 ... +176
	I7S23,5-N		-40 ... +131	-40 ... +158	-40 ... +176
M40./../ESK4	ESK4		-40 ... +131	-40 ... +158	-40 ... +176
M40./../ESK4-T	ESK4 and I/O modul		-40 ... +126	-40 ... +153	-40 ... +171
M40./../ESK4-FF	ESK4 and ESK4-FF		-40 ... +97	-40 ... +124	-40 ... +169
M40./../ESK4-PA	ESK4 and ESK4-PA				

2.8 Electrical data

Electrical equipment	Rated voltage	Nominal current
Limit switch K1 / K2	8 VDC	≤1 / ≥3 mA
Signal output ESK4	14 - 32 VDC	4...20mA with HART® communication
Switching output ESK4-T OC output	8 - 32 VDC	1...100 mA
Switching output ESK4-T NAMUR output	8 VDC	≤1 / ≥3 mA
Signal input ESK4-T input	8 - 32 VDC	≤2 mA
ESK4-FF Foundation Fieldbus transmitter ①	9 - 32 VDC	16 mA
ESK4-PA Profibus transmitter ②	9 - 32 VDC	16 mA

① Further information and instructions for operation of the ESK4-FF transmitter are provided in separate supplementary instructions.

② Further information and instructions for operation of the ESK4-PA Profibus transmitter are provided in separate supplementary instructions.

3.1 Installation

Installation and setup must be carried out according to the applicable installation standards (e.g. EN 60079-14) by qualified personnel trained in explosion protection. The information given in the Installation and Operation Instructions and the Supplementary Installation and Operation Instructions must always be observed.

Variable area flowmeters must be installed in such a way that

- There is no danger from mechanical impact effects.
- There are no external forces affecting the indicator part.
- The device is accessible for any visual inspections that are necessary, and can be viewed from all sides.
- The nameplate is clearly visible.
- It can be operated from a location with secure footing.

Take special note of the installation position for the H250/H/... with horizontal flow direction:

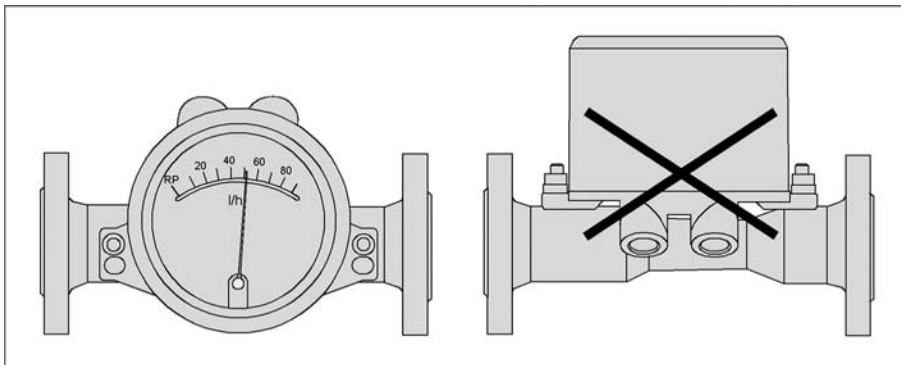

In order to comply with thermal parameters and measuring accuracy, flowmeters for horizontal installation are to be installed in the pipeline so that the display is located on the side of the measuring tube. The maximum product and ambient temperatures indicated as well as the measuring accuracy are based on lateral installation of the display.



CAUTION!

The manufacturer is not liable for any damage resulting from improper use or use other than the intended purpose. This applies in particular to hazards due to insufficient corrosion resistance and suitability of the materials in contact with product.

4.1 General notes

The built-in equipment is connected electrically in the integrated terminal compartment of the display.

The connecting cables should be selected according to the applicable installation standards (e.g. EN 60079-14) and the maximum operating temperature.

- Before connecting or disconnecting the electric connecting cable of the device, ensure that all of the cables leading to the signal converter are de-energised relative to each other and to the reference potential of the hazardous area. This also applies to earthing conductors (FE) and equipotential bonding conductors (PA).
- The connecting cables must be fixed and laid so they are sufficiently protected against damage.
- All cores that are not used must be securely connected to the earth potential of the hazardous area or carefully insulated against each other and against ground (test voltage $\geq 500 V_{\text{eff}}$).
- Lay cables so as to ensure that there is sufficient distance between surfaces of the measuring unit and the connecting cable.
- Supplied blind plugs / cable entries guarantee protection against foreign bodies and water (protection category) IP66 / 67 according to EN 60529 in the temperature range $T_{\text{amb}} = -40 \dots +100^{\circ}\text{C} / -40 \dots +212^{\circ}\text{F}$.
- The outer diameter of the connecting cable must be within the sealing range of the cable entry (7...12 mm / 0.28...0.47").
- Unused cable entries are to be closed (>IP66 / 67). Supplied plugs should be replaced with suitable connecting cables.
- Tighten the signal circuit terminals with a tightening torque of 0.5 ... 0.6 Nm.

Ensure that the seals and cut seals are tight.

4.2 Power supply

The variable area flowmeter does not require any separate power supply. The necessary power for the built-in electrical equipment is supplied via the signal circuits.

4.3 Inputs/outputs

The signal circuits of the variable area flowmeter may only be connected to downstream devices or circuits that satisfy the requirements of protective extra-low voltage (PELV). The terminal assignment of the built-in electrical equipment is described in the Standard Installation and Operation Instructions.

Only circuits that are suitable for operation in zone 2 hazardous areas may be connected. Outside of the variable area flowmeter, measures must be taken for the circuits to prevent the rated voltage from being exceeded by more than 40% due to temporary faults.

4.4 Grounding and equipotential bonding

The variable area flowmeter must be included in the equipotential bonding of the hazardous area. It is connected to the PA terminal on the display. Alternatively, equipotential bonding can occur via grounded pipelines.

Any existing cable shields should be connected to earth according to applicable installation regulations (EN 60079-14). A terminal connection in the terminal compartment permits a short way earthing of the cable shields.

5.1 Start-up

Start-up is only permitted when the variable area flowmeter:

- is correctly installed in the system and connected.
- has been checked for the proper state with regard to its installation and connection requirements.
- has been properly sealed in the electronic compartment or there is no explosive atmosphere present.

The user of the system must have it checked before start-up in compliance with the national regulations for checks before startup.

If the device needs to be configured due to the existence of an explosive atmosphere, this can be done using the supplied programming magnets. There is no need to open the housing as it can be done through the glass window of the electronics compartment or digitally via the signal output (HART® interface)

5.2 Operation

Variable area flowmeters must be operated in such a way that they remain within the maximum and minimum permissible temperatures and pressures and the electrical limit values.

Variable area flowmeters may only be operated if the equipment parts necessary for safety are effective in the long run, and are not rendered inoperable during operation.

During operation it is only permitted to open the indicator if no explosive atmosphere is present.



WARNING!

Ignition risks caused by pressure surges, impact or friction must particularly be avoided when titanium measuring units are used.

5.3 Electrostatic charge

In order to avoid ignition hazards due to electrostatic charge, variable area flowmeters may not be used in areas with:

- processes that generate strong charges,
- mechanical friction and cutting processes,
- spraying of electrons (e.g. in the vicinity of electrostatic painting systems).



WARNING!

Electrostatic charging of the housing surface by friction must be avoided. Variable area flowmeters must not be dry cleaned.

6.1 Maintenance

Maintenance work of a safety-relevant nature within the meaning of explosion protection may only be carried out by the manufacturer, his authorised representative or under the supervision of authorised inspectors.

To maintain proper condition, regular inspections are required for systems in hazardous areas.

The following checks are recommended:

- Checking the housing, the cable entries and the feed lines for corrosion and/or damage.
- Checking the measuring unit and the piping connections for leakage.
- Checking the measuring unit and the indicator for dust deposits.
- Including the flowmeter in the regular pressure test of the process line.

6.2 Dismantling

Exchanging the built-in equipment

Due to the modular structure of the variable area flowmeters, from a safety point of view it is possible to exchange the electrical equipment built into the indicator for identical spare parts.

To do so, remove the housing cover. The housing cover must be closed immediately after the spare parts are exchanged. Make sure that the cover seal is properly seated.



CAUTION!

There may be a loss of measuring accuracy!

Exchanging the entire device

Removal and installation are the responsibility of the operator.

Before disconnecting the electric connecting cable of the device, make sure that all cables leading to the indication unit are isolated from the ground of the hazardous area. This also applies to functional earthing conductors (FE) and equipotential bonding conductors (PA).



WARNING!

- *Pressurized pipes have to be depressurized before removing the measuring unit.*
- *In the case of environmentally critical or hazardous products, appropriate safety precautions must be taken with regard to residual liquids in the measuring unit.*
- *New gaskets have to be used when re-installing the device in the piping.*



KROHNE product overview

- Electromagnetic flowmeters
- Variable area flowmeters
- Ultrasonic flowmeters
- Mass flowmeters
- Vortex flowmeters
- Flow controllers
- Level meters
- Temperature assemblies
- Pressure transmitters
- Analysis products
- Products and systems for the oil & gas industry
- Measuring systems for the marine industry

Head Office KROHNE Messtechnik GmbH
Ludwig-Krohne-Str. 5
47058 Duisburg (Germany)
Tel.: +49 203 301 0
Fax: +49 203 301 103 89
info@krohne.com

The current list of all KROHNE contacts and addresses can be found at:
www.krohne.com

KROHNE