

## Addition to the installation and operating instructions

### IFC 090 F-EEEx IFC 090 F / i-EEEx

#### Signal converters for electromagnetic flowmeters

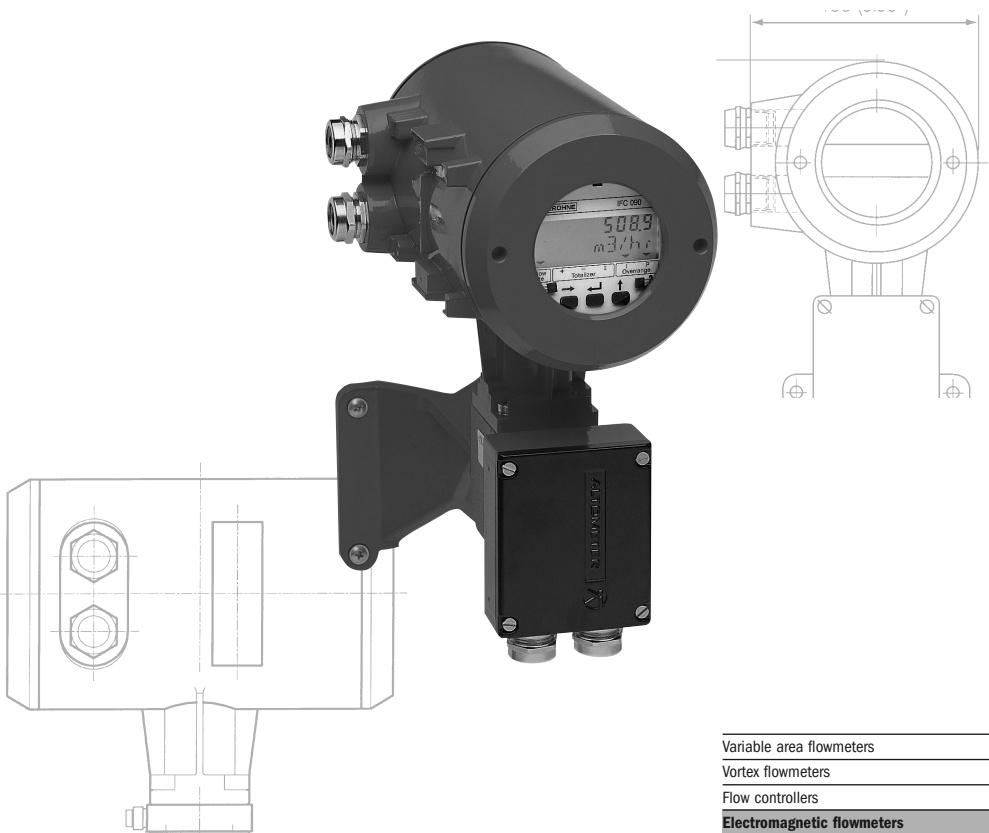

Variable area flowmeters
Vortex flowmeters
Flow controllers
<b>Electromagnetic flowmeters</b>
Ultrasonic flowmeters
Mass flowmeters
Level measuring instruments
Communications technology
Engineering systems & solutions
Switches, counters, displays and recorders
Heat metering
Pressure and temperature

<b>WARNING !</b>	No changes regarding safety may be made to the devices. Unauthorized changes might affect the explosion safety of the devices.
------------------	--

Be sure to follow these instructions !

<b>IMPORTANT !</b>	<ul style="list-style-type: none"> <li>• The prescriptions and regulations as well as the electrical data described in the EC-type examination certificate must be obeyed.</li> <li>• Beside the instructions for electrical installations in non-hazardous locations according to the applicable national standard (e.g. IEC 364), especially the regulations in EN 60079-14 "Electrical installations in hazardous locations" or equivalent national standard must be followed.</li> <li>• Installation, establishment, utilization and maintenance are only allowed to be executed by personnel with an education in explosion safety!</li> </ul>
--------------------	--

These additional instructions are an extension to the Installation and Operating Instructions and only apply to the EEx version of the IFC 090 F - EEx or IFC 090 F / i -EEx signal converter. All technical information described in the "Installation and Operating Instructions" are applicable, when not specifically excluded, completed or replaced by the instructions in these additional instructions.

## Contents

<b>1</b>	<b>System components</b>	<b>3</b>	
1.1	General information		3
1.2	IFS x000 F-EEx primary head		3
1.3	IFC 090 / ... -EEx signal converter		4
1.3.1	Electronic compartment		4
1.3.2	Terminal compartment		4
1.4	Data plates		5
1.5	Electronic unit		5
<b>2</b>	<b>Electrical connection</b>	<b>7</b>	
2.1	Equipotential bonding system		7
2.2	Intermediate junction box ZD-EEx		7
2.3	Connecting cables		7
2.4	Connecting diagram		9
2.5	regular IFC 090 - EEx electronic unit		11
2.6	MODIS version IFC 090 I - EEx electronic unit		12
2.7	Connecting diagrams MODIS		13
<b>3</b>	<b>Operation of the signal converter</b>	<b>20</b>	
<b>4</b>	<b>Maintenance</b>	<b>20</b>	
<b>5</b>	<b>Service</b>	<b>21</b>	
5.1	General information for replacements		21
5.2	Replacement of electronic unit		22
5.3	Replacement of power fuses		24
5.4	Changing power supply voltage		27
<b>6</b>	<b>Ordering information</b>	<b>28</b>	
<b>7</b>	<b>Declaration of conformity</b>	<b>29</b>	
<b>8</b>	<b>EC-type examination certificates</b>	<b>30</b>	

---

# 1 System components

---

## 1.1 General information

The ALTOFLUX IFC 090 F/...-EEx signal converter complies with the European Directive 94/9/EC (ATEX 100a) and has been approved for hazardous classified locations of Zone 1 and 2 by the KEMA conform the European Standards of the EN 500xx series. The IFC 090 F/...-EEx has the following EC-type examination Certificate number:

### **KEMA 01 ATEX 2234**

The signal converter is available in two types, namely:

IFC 090 F-EEx regular explosion protected version;

IFC 090 F/i-EEx, MODIS version. This type has intrinsically safe signal output circuits, which are provided by two installed MODIS modules (see Sect. 1.5 for details).

The regular IFC 090 F-EEx signal converter is designed for ambient temperatures in the range of -40°C up to +60°C, the so-called MODIS version type IFC 090 F/i-EEx is rated for ambient temperatures from -20°C up to +60°C. Both types of signal converters are in remote design, which means that they are installed on a certain distance of the measuring unit, the IFS x000 F-EEx series of primary heads. The primary heads are approved according to the European Directive 94/9/EC (ATEX 100a) as well. Due to the installation on a distance from the primary head, the signal converter is independent of the process liquid temperature and therefore rated for temperature class T6 and a T85°C for dusts.

The IFC 090 F / ... EEx signal converter is marked with the following code below:

Regular version II 2GD EEx de [ib] IIC T6

MODIS version II 2GD EEx de [ia] [ib] IIC T6

Also see the EC-type Examination Certificate in Sect. 8 of these instructions.

## 1.2 IFS x000 F-EEx primary head

The IFS x000 F-EEx series primary head is the measuring unit of the IFC 090 F/...-EEx signal converter and contains two field coils and two electrodes in type of protection intrinsic safety category "ib" according to EN 50020. The type of protection of the field coils depends on the meter type and size, see the additional installation and operating instructions of the primary head concerned.

The electrode circuits are wired by separate shielded cables and marked by the sheath color (white and purple). The intrinsical safe "ib" electrode circuits inside the IFS x000 F-EEx primary head have the following maximum values (entity parameters):

Maximum input voltage	$U_{\max} = 20 \text{ V}$
Maximum output current	$I_{\max} = 170 \text{ mA}$
Maximum internal capacitance	$C_i = 0$
Maximum internal inductance	$L_i = 0$

The two field coils inside the primary head are connected in series and provided with the type of protection increased safety "e" conform to EN 50019 and additionally flameproof enclosure "d" in accordance with EN 50018 or encapsulation "m" according to EN 50028. The coils have a maximum resistance below 90  $\Omega$  per coil with a wire diameter of at least 0.25 mm and insulation class H ( $T_{\max} \geq 180^\circ\text{C}$ ) according to IEC 85. The field coils are supplied with a square-wave signal with a peak voltage of 60 V maximum and a nominal current of 125 mA. The coil circuit is protected by two series fuses in the IFC 090 ...-EEx electronics unit. The fuses are rated for a maximum voltage of 250 Vac @ 50-60 Hz, have a breaking capacity of at least 35 A and switching characteristics fast (F) to time-lag (T).

### 1.3 IFC 090/...-EEx signal converter

The IFC 090/...-EEx signal converter consists of the pre-certified cylindrical housing of die-casted aluminum (type AX/P-EEx with KEMA No. Ex-99.E.8128 U). It has two separate compartments, divided from each other by an integrated wall with casted flameproof terminal feed-through. The neck at the bottom of the housing that is connected to the wall-mounting bracket with junction box, contains flameproof cable feed-through type LC-2/EEx, which is approved by KEMA under No. Ex-01.E.2036 U. The wall-mounting bracket and junction box are also made of die-casted aluminium. The signal converter housing is on both ends closed by a cylindrical cover with M115x2-6H6g screw-thread and O-ring sealing. The signal converter has an ingress protection degree of IP 65 / IP 67 conform to EN 60529.

#### 1.3.1 Electronics compartment

The electronics compartment accommodates the pre-certified IFC 090...-EEx electronics unit with approval number PTB 98 ATEX 2012 U. The compartment is designed with type of protection flameproof enclosure "d" according to EN 50018 and closed by a threaded flameproof display cover. The IFC 090...-EEx unit is inserted into the electronics compartment via two sliding rubbers that position and fixate it at the front in the housing. Two M4 screws mount the unit and a third M4 screw fixates the copper earth strip at the back-end of the safety barrier printed circuit board. The three screws are screwed to the integrated aluminium wall in-between terminal and electronics compartment. The safety barrier provides the electrodes inside the primary head with type of protection intrinsic safety "ib" according to EN 50020.

See tables on the next pages for the electrical data of the available power supplies (e.g. mains voltages, etc.). The safety barrier has the following maximum values (entity parameters):

Maximum output voltage	$U_0 = 9 \text{ V}$
Maximum output current	$I_0 = 38 \text{ mA}$
Maximum allowed external capacitance	$C_0 = 4.9 \text{ }\mu\text{F}$
Maximum allowed external inductance	$L_0 = 23 \text{ mH}$

#### 1.3.2 Terminal compartment

The terminal compartment has seven M4 clamp terminals for connection of the power supply and signal output circuits (binary and current outputs). Section 2 shows the terminal arrangement for the regular and MODIS version of the IFC 090/...-EEx signal converter. The terminals are separated from each other by insulation plates (nine in total, one at each end). The terminal arrangement of the MODIS version (i.e. IFC 090i-EEx) is shown in Sect. 2.6. Two of the terminals are used for connection of the non-intrinsically safe power supply and four terminals (marked with "\*\*\*\*") for the intrinsically safe, category "ia" signal outputs (i.e. current, pulse resp. status output) of the MODIS modules. The non-intrinsically and intrinsically safe terminals are separated from each other by a metal dividing plate, which is screwed to the remaining (not connected) M4 terminal. The two non-intrinsically safe power supply terminals are covered by an insulating plate.

The terminal compartment (with standard type of protection increased safety "e") is standard equipped with two ATEX or E-generation approved "EEx e" cable glands. The terminal compartment can also be provided as a flameproof enclosure "d", in which case ATEX or E-generation approved "EEx d" cable glands of size Pg13.5, Pg16 or M20x1.5 are factory installed or must be installed by the customer. For flameproof conduit systems, the terminal compartment must have type of protection flameproof enclosure "d" according to EN 50018. The conduits must be sealed by "EEx d" approved (within the ATEX 100a directive) sealing devices (i.e. stopping box) directly at the conduit entrances of the as flameproof enclosure performed terminal compartment. All used cable glands, blind plugs and sealing devices for conduit systems must have an ingress protection degree of IP65 or better.

## 1.4 Data plates

### IFC 090 F-EEEx

### IFC 090 F / i-EEEx

Terminals	Passive circuits
1/11	Ua 9V, Ia 38mA; Pa 34mW Ca=4.8μF; Ia=25mA; IFC 090 F-EEEx
1/11, 2/2/22	Passive output Ua=30V, Ia=250mA; Pa=7.5W Ca=10μF; Ia=30mA; IFC 090 F-EEEx
1/11	Passive output Ua=30V, Ia=300mA; Pa=9W Ca=10μF; Ia=30mA; IFC 090 F-EEEx
1/11, 2/2/22	Active output Ua=23.5V, Ia=88mA; Pa=2.06W Ca=10μF; Ia=40mA; IFC 090 F-EEEx

## 1.5 Electronics unit

The IFC 090 F/...-EEEx signal converter can be equipped with the regular IFC 090-EEEx electronics unit or with the IFC 090i-EEEx electronics unit with intrinsically safe signal outputs (i.e. MODIS version). The regular signal converter design has type designation IFC 090 F-EEEx and the MODIS version is designated as IFC 090 F/i-EEEx.

### Regular IFC 090-EEEx electronics unit

The IFC 090-EEEx can be equipped with one of the following power supplies, which depends on the mains supply voltage in area of application.

### Electrical data of power supply

Power supply	Terminal	Description	Supply voltage	Tolerance	Power
AC-versions	L	Live	115/230 Vac 100/200 Vac	-15%/+10%	10 VA
	N	Neutral			
	PE	Protective Earth			
AC/DC-version	1L≈	Live	24V ac/dc	AC: -15%/+10% DC: -25%/+30%	AC: 10 VA DC: 8 W
	0L≈	Neutral			
	FE	Functional Earth			

The above listed power supplies are protected by a mains fuse rated according the next table.

## Mains fuses

Power supply		Mains fuse	
Type	Nominal voltage	Rating	Specifications
AC-versions	100/115 Vac	200 mA	Switching char.: fast (F) to time-lag (T)
	200/230 Vac	125 mA	Breaking capacity: $\geq 1500$ A @ 250 V
	24 Vac	1.25 A	Switching char.: fast (F) to time-lag (T)
DC-version	24 Vdc		Breaking capacity: $\geq 300$ A @ 65 V

The IFC 090-EEEx electronics unit is equipped with the following in-/output circuits. Terminals B1, B $\perp$  and B2 can be configured as status or pulse outputs or as control inputs via the software. See the table below for the electrical data of these in-/output circuits.

### Electrical data of in-/output circuits

Terminals	Description	Nominal voltage	Maximum current
B1, B $\perp$ , B2	Pulse, status, control in-/outputs	32 V	150 mA
I+, I	Current output	15 V	22 mA

The difference between 115/230 Vac version and the 100/200 Vac version is the number of the primary windings of the mains transformer.

The terminals indicated as B1, B $\perp$  and B2 can be configured as pulse in-/outputs by jumpers. The IFC 090-EEEx electronics unit is provided with an extension module that is used for data communication (e.g. SMART, HART or RS485). In that case, the current output signal (I+, I) is superposed with a sinusoidal voltage signal of 0.5 V. The extension module does not significantly influence the nominal voltage  $U_n$ , the nominal current  $I_n$  or the power dissipation.

### Overheating protection

The mains transformer is protected against overheating by a temperature breaker in series with the primary winding. The temperature breaker is casted within the compound of the transformer and has an opening temperature of 125 °C ( $\pm 5$  K).

### IFC 090i-EEEx unit with MODIS modules

The IFC 090i-EEEx electronics unit is equipped with two MODIS-modules. It is equipped with one of the following power supplies.

### Electrical data of IFC 090i-EEEx electronics unit

Power supply	Terminal	Function	Electrical data
AC-version	L N PE	Live Neutral Protective ground	$U_n = 100\dots 230$ Vac $-15\%/+10\%$ $P_n = \text{approx. } 15$ VA  Primary fuse: Rated current: 1.6 A Design conform IEC 127-2 Breaking capacity: 1500 A
AC/DC-version	1L $\approx$ 0L $\approx$ FE	Live Neutral Functional ground	$U_n = 24$ V ac / dc AC: $-15\%/+10\%$ or $20.4\dots 26.4$ V ac DC: $-25\% / +30\%$ or $18\dots 32$ V dc $I_n =$ approx. 490...630 mA for AC approx. 310...550 mA for DC $P_n =$ approx. 10 W  Primary fuse: Rated current: 1.25 A Design conform IEC 127-2 Breaking capacity: 1500 A

**NOTE:** The mains fuses for both electronics units are listed in Sect. 6 of this manual.

---

## 2 Electrical connection

---

### 2.1 Equipotential bonding system

The IFC 090 F/...-EEx signal converter must always be incorporated into the equipotential bonding system of the hazardous area. This connection can be achieved through the PE/FE conductor connected to the PE terminal in the terminal compartment (see figure of terminal arrangement) or through a separate PE conductor, cross sectional area at least 4 mm<sup>2</sup>, connected to the external PE clamp, placed below the converter housing.

### 2.2 Intermediate junction box ZD-EEx

For safety reasons, standard cables with a rubber or thermoplastic insulation sheath may only be used up to a continuous operating temperature of 70°C at the cable entry and 80°C at the branching point of the connecting cables. In case that the temperature at the above mentioned parts exceed the maximum values, heat-resistant cables must be installed at the IFS x000 F-EEx primary head in remote design. Also see the EC-type examination certificate of the primary head.

The table below summarizes the conditions for use of heat-resistant cables for the IFS x000 F-EEx primary head.

#### Use of heat-resistant cables

Primary head	Meter size	Ambient temperature	Process liquid temperature
IFS 4000 F-EEx	DN25 - 150	≤ 40°C ≤ 50°C ≤ 60°C	not required ≥ 155°C ≥ 105°C
	≥ DN200	≤ 40°C ≤ 50°C ≤ 60°C	not required ≥ 145°C ≥ 110°C
IFS 5000 F-EEx	DN2.5 - 100	≤ 40°C ≤ 50°C ≤ 60°C	≥ 165°C ≥ 130°C ≥ 100°C
IFS 6000 F-EEx	DN2.5 - 80	≤ 40°C ≤ 50°C ≤ 60°C	not required ≥ 160°C ≥ 115°C

In case that heat-resistant cables are required, install the intermediate junction box ZD-EEx at a distance of approximately 5 m from the primary head. Connect heat-resistant cables (see cables D and E in the next section) between the primary head's junction box and the intermediate junction box ZD-EEx. The standard cables (types B and C) can be used between the IFC 090 F/...-EEx signal converter and intermediate junction box. See connection diagram 2.

The silicone rubber insulated connection cable for the magnetic field coils must be protected against mechanical damages between the primary head and intermediate junction box by a conduit system with edge protections. Intermediate box ZD-EEx has terminals with type of protection increased safety "e" conform to EN 50019. The intermediate box is incorporated in the equipotential bonding system of the installation via its external clamp terminal.

### 2.3 Connecting cables

**NOTE:** The following described cables are shown in the next connection diagrams.

#### Cable A

Signal cable for current output and binary outputs (pulse and status output): The cable parameters must be in accordance with the regulations in the EN 60079-14 "Electrical installations in hazardous locations" or an equivalent national standard. For the MODIS version with IFC 090i-EEx electronics unit (right detail in connection diagram 1) the signal cable for the intrinsically safe signal in-/outputs must also conform the requirements as specified in the relevant standard national code of practice for the installation of electrical apparatus with type of protection Intrinsic Safety "i".

### Cable B

Power supply cable: The cable parameters must be in accordance with the regulations of the EN 60079-14 "Electrical installations in hazardous locations" or an equivalent national standard.

The PE terminal must be connected to the protective ground conductor of the mains supply.

Rated voltage	≥ 500 V
Cross-sectional area of core	1.5 to 2.5 mm <sup>2</sup>
Examples	H07...-, H05...-

### Cable C

	Type DS blue Intrinsic safe, with <b>double</b> shielding	Cable constants (typical values at Ta = 20°C)
	1 Stranded drain wire, 1st shield, 1.5 mm <sup>2</sup> 2 Insulation 3 Stranded wire, 0.5 mm <sup>2</sup> 4 Special foil, 1st shield 5 Insulation 6 Mu-metal foil, 2nd shield 7 Stranded drain wire, 2nd shield, 0.5 mm <sup>2</sup> 8 Outer sheath (flame-retardant)	C'3/3 60 pF/m (1 kHz) C'3/4 110 pF/m (1 kHz) C'4/6 290 pF/m (1 kHz)  L'3/3 0.85 μH/m (1 kHz) L'3/4 0.60 μH/m (1 kHz)  R'3 37 mΩ/m R'4+1 12 mΩ/m

### Cable D

Intrinsic safe, with **single** shielding. Heat-resistant conform to VDE 0165/02.91.

#### Properties

Continuous service temperature	≥ 120°C
Test voltage	≥ 500 V
Capacitance:	≤ 200 pF/m
	≤ 200 pF/m
Inductance:	≤ 1 μH/m
Cable length	≤ 5 m
Single-wire-Ø:	≥ 0.1 mm
Cross-sectional area of core	0.5 to 1.5 mm <sup>2</sup>
Sheath	light-blue or in other way color-coded as intrinsic safe, flame-retardant.
Example	Silicone rubber insulated, shielded control cable.

### Cable E

Non-intrinsic safe, **2-core** without shielding. Heat-resistant conform to VDE 0165/02.91.

#### Properties

Continuous service temperature	≥ 120°C
Test voltage	≥ 500 V
Cross-sectional area of core	1.5 mm <sup>2</sup>

#### Bonding conductor

Cross-sectional area	Max. 4 mm <sup>2</sup>
----------------------	------------------------



## 2.4 Connection diagrams

### Connection diagram 1: Standard cables

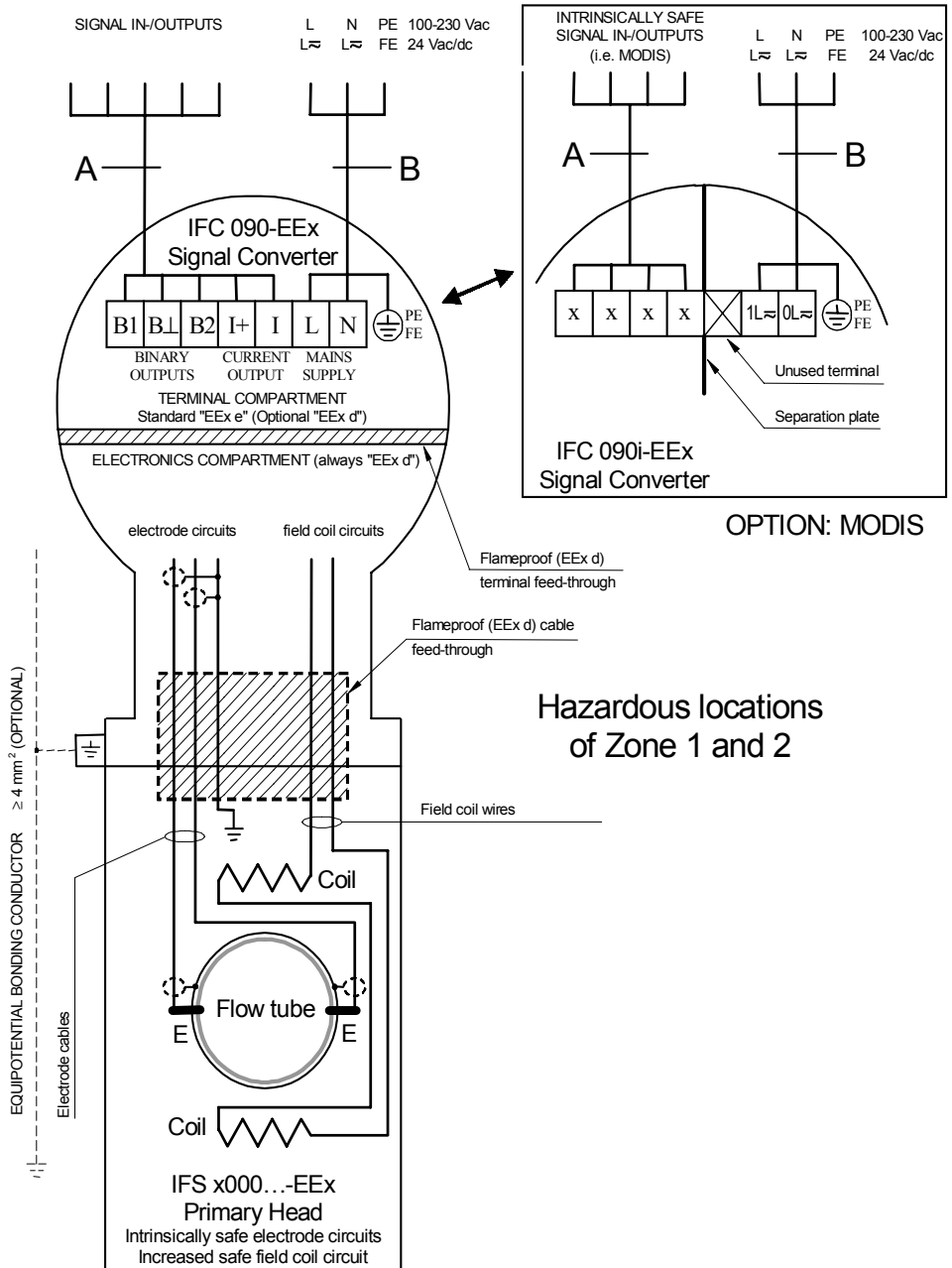

## Connection diagram 2: Use of heat-resistant cables

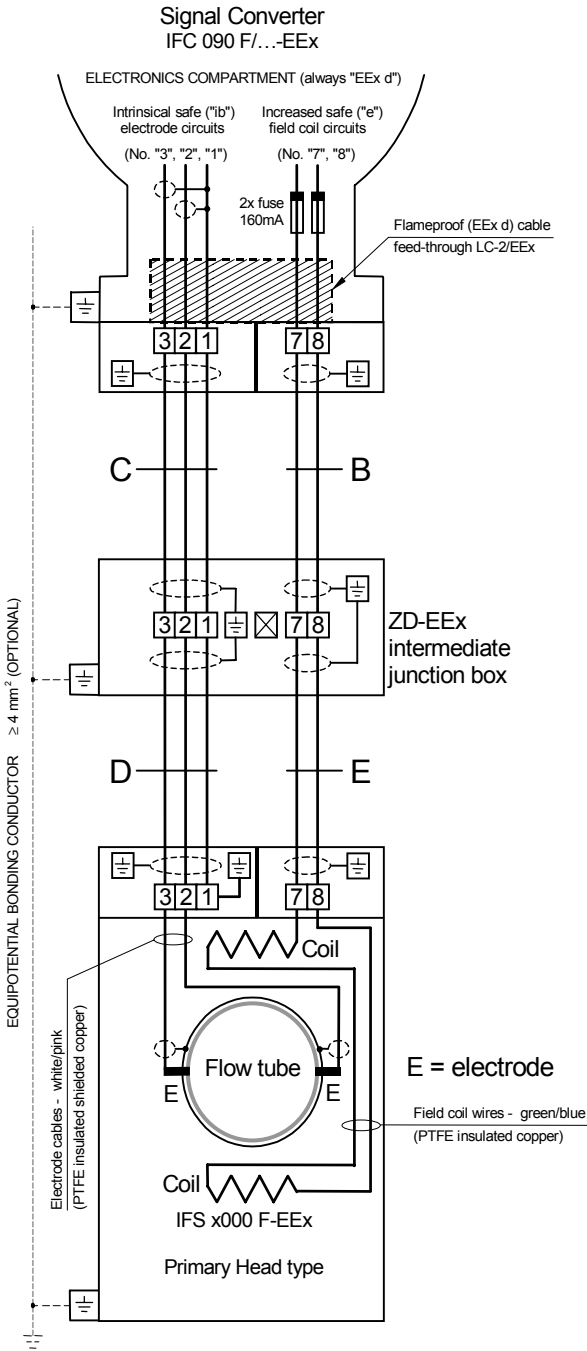

Hazardous locations  
of Zone 1 and 2

## 2.5 Regular IFC 090-EEEx electronics unit

The field cables that enter the terminal compartment of the IFC 090-EEEx signal converter unit (i.e. power supply, current and binary outputs) are non-intrinsically safe. To connect external devices to the signal output terminals, the wiring requirements for the type of protection of the compartment (standard: increased safety "e", optional: flameproof "d") must be conform to the international or national standard involved (e.g. EN 60079-14).

Terminal arrangement in terminal compartment	
pulse and status outputs or control inputs	
binary outputs	current output
	L N L≈ L≈
	100 - 240 V AC / 48 - 63 Hz 24 V AC / DC
	PE Protective earth FE Functional earth
Passive pulse/status output	Active current output
$I \leq 150 \text{ mA}$ electronic or electro-mechanical totalizer	$I \leq 150 \text{ mA}$ $U_{\text{ext}} \leq 32 \text{ V DC}$ $\leq 24 \text{ V AC}$ e.g. signal indicator
	$R_i \leq 500 \Omega$

**Note:** The binary outputs (terminals B1, B $\perp$  and B2) can only be configured as passive outputs, the current output (terminals I+ and I) can only be configured as active output.

For power supply versions with the nominal voltage in the range of 100 to 230 Vac the PE conductor must always be connected to the M5 clamp terminal marked with the safety earth symbol that is press-fitted in the dividing aluminium wall of the signal converter housing. For the 24 Vac/dc power supply, the PE conductor may be connected, but it not required for the safety of the flowmeter. The terminal arrangement is shown above.

## 2.6 MODIS version IFC 090i-EEx electronics unit

The field cables of the non-intrinsically safe power supply and the intrinsically safe, category "ia" signal outputs enter the terminal compartment of the IFC 090i-EEx signal converter unit via two separate entrances. To connect external devices to the intrinsically safe signal output terminals, the wiring requirements for their type of protection as well as of the compartment (standard: increased safety "e", optional: flameproof enclosure "d") must conform to the international or national standard involved (e.g. EN 60079-14).

### Terminal arrangement in terminal compartment

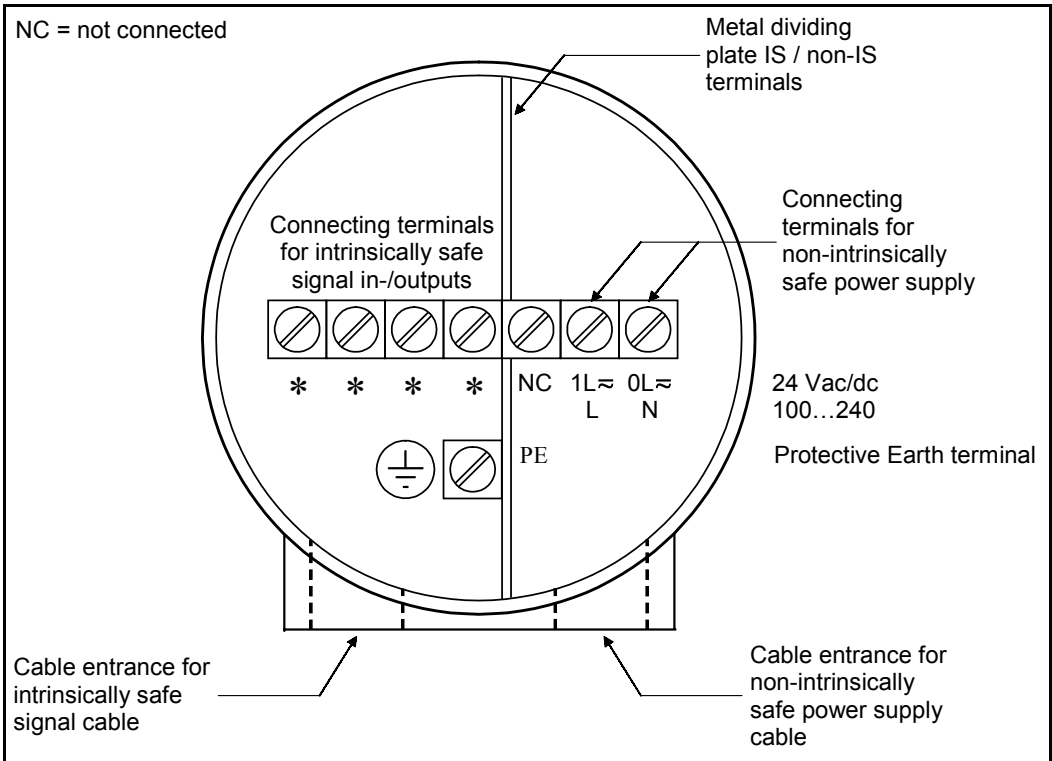

The non-intrinsically safe terminals for connection of the power supply (1L ≈ and 0L ≈) must be connected according to the relevant standard code of practice for electrical apparatus intended for use in potentially hazardous locations, type of protection Increased Safety "e" or type of protection Flameproof Enclosure "d", depending on the type of protection of the terminal compartment of the signal converter housing.

To gain access to the connection terminals of the power supply, the half-circular cover plate of insulating material must be slightly lifted at one end and then rotated downwards, see the instruction on the cover plate. After connection of the power supply cable, the half-circular cover plate must be restored into its original position, so that the minimum clearances and creepage distances towards the intrinsically safe signal in-/output terminals are maintained.

For details, see diagram on terminal compartment MODIS on next page.

## Terminal compartment MODIS version IFC 090i-EEEx

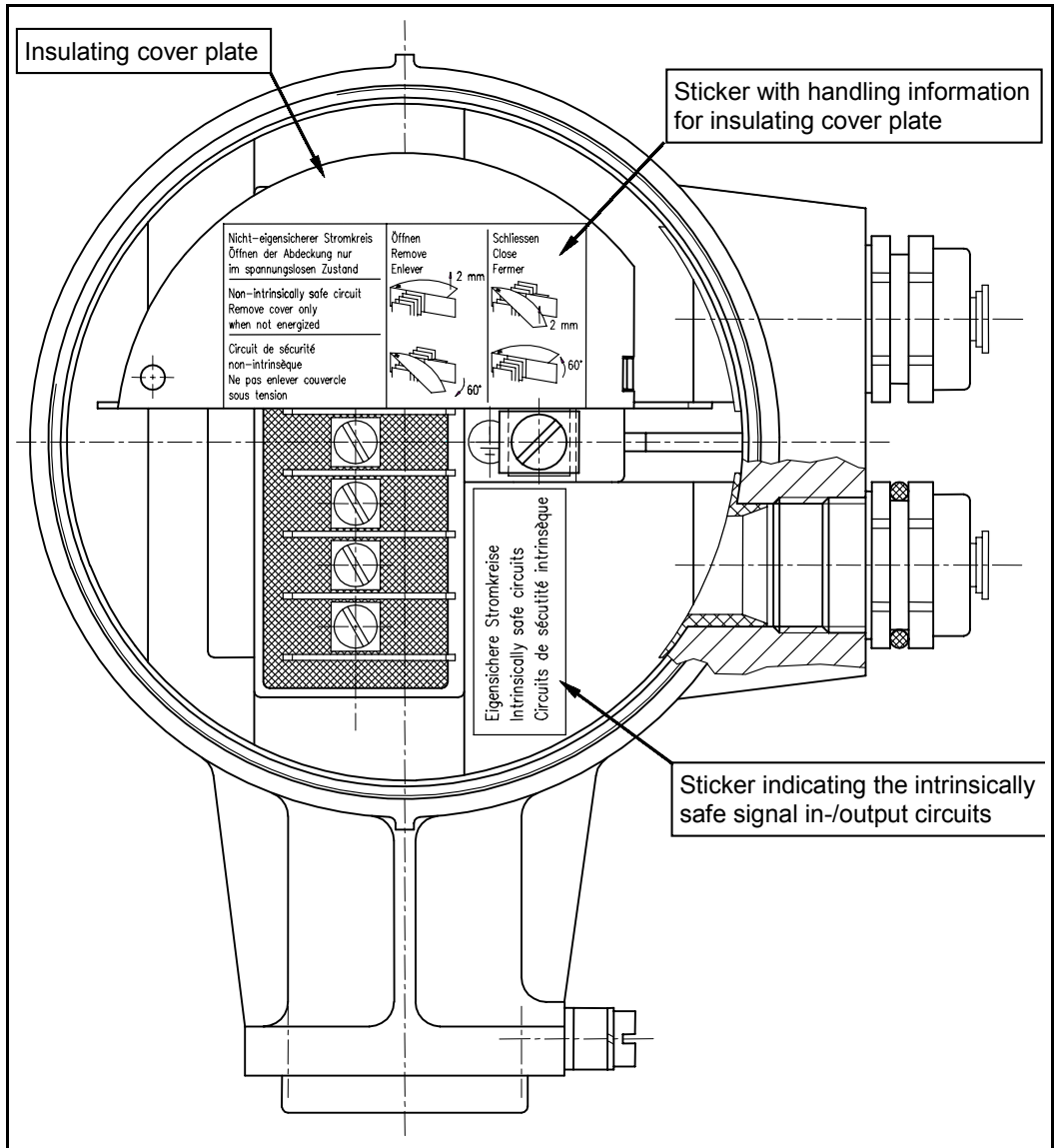

The PE (or FE) conductor must be connected to the press-fitted M5 clamp terminal marked inside the terminal compartment. This conductor must be guided through the rectangular opening in the metal dividing plate that separates the non-intrinsically safe power supply terminals from the intrinsically safe signal in-/output terminals.

### 2.7 Connection diagrams MODIS

Sect. 2.4 shows the block diagrams of the EEx electromagnetic compact flowmeter. The power supply (terminals 1L $\approx$ , 0L $\approx$ ) is connected via cable B. The PE terminal must be connected to the protective earth conductor of the mains supply.

The IFC 090i-EEEx electronics unit is provided with intrinsically safe signal in-/output circuits due to the installed pair of MODIS modules in accordance with the table below.

## Overview of MODIS modules

Module	Terminal designation	Function / Intrinsically safe maximum data
<b>P-SA</b>	I ⊥, I	Current output (0/4-20 mA), passive $U_i = 30 \text{ V}$ , $I_i = 250 \text{ mA}$ , $P_i = 1.0 \text{ W}$ $C_i = 5 \text{ nF}$ , $L_i \approx 0$
<b>FA-ST</b>	B1, B1⊥ or B2, B2⊥	Pulse (frequency) output or status in-/output, all passive The function can be set by software $U_i = 30 \text{ V}$ , $I_i = 250 \text{ mA}$ , $P_i = 1.0 \text{ W}$ $C_i = 5 \text{ nF}$ , $L_i \approx 0$
<b>F-PA</b>	D, D⊥	Fieldbus module, type Profibus system, passive $U_i = 30 \text{ V}$ , $I_i = 300 \text{ mA}$ , $P_i = 4.2 \text{ W}$ $C_i = 5 \text{ nF}$ , $L_i \approx 0$
<b>F-FF</b>	D, D⊥	Fieldbus module, type Fieldbus Foundation, passive $U_i = 30 \text{ V}$ , $I_i = 300 \text{ mA}$ , $P_i = 4.2 \text{ W}$ $C_i = 5 \text{ nF}$ , $L_i \approx 0$
<b>DC-I</b>	I+, B1+	Intrinsically safe voltage source for the passive module P-SA or FA-ST, so that active operation is possible. $U_o = 23.5 \text{ V}$ , $I_o = 98 \text{ mA}$ , $P_o = 0.6 \text{ W}$ $C_o = 132 \text{ nF}$ , $L_o = 4 \text{ mH}$  <b>Note!</b> When modules P-SA (or FA-ST) and DC-I are connected in series, the internal capacitance $C_i$ of 5 nF must be subtracted from the $C_o$ of 132 nF. So the data plate will list a $C_o$ of 127 nF.

Besides the shown intrinsically safe maximum values for voltages and current -which are based on certain fault conditions as prescribed by the standard EN 50 020 - the nominal values for current and voltage must also be respected otherwise a proper functioning of the modules is not guaranteed!

### Nominal voltage and current values for the MODIS modules

MODIS module	Nominal values for voltage and current
<b>P-SA</b> (passive current output )	Current: 4 ... 20 mA Working voltage: 8 ... 30V Voltage drop : 8V at 4mA
<b>FA-ST</b> (frequency / pulse / status output or control input)	Working voltage: 6 ... 30V Working current: 110 mA Voltage drop: in ON-state: < 2V at 110 mA Leakage current in OFF-state: < 900 μA at 30V  Control input: Input voltage LOW level: < 3V Input voltage HIGH level: > 7V Frequency range : 0 .. 12 KHz
<b>DC-I</b> (active voltage source)	Voltage: 20V Current: 30 mA Internal resistance: 260 Ω

The active module DC-I is needed in the 24 Vac/dc power supply version to form an active current or pulse output in combination with one of the passive modules P-SA or FA-ST. Due to limited space it is not available for 100...230 Vac supply versions.

**Possible combinations of the installed MODIS modules for the 24 Vac/dc power supply version of the IFC 090i-EEEx**

IFC 090i-EEEx version	Part No.	MODIS modules		Terminal designation			
Ex-i1	2.11582.01.00	P-SA	FA-ST	I ⊥	I	B1	B1 ⊥
Ex-i2	2.11582.03.00	P-SA	F-PA	I ⊥	I	D	D ⊥
Ex-i3	2.11582.02.00	P-SA	DC-I	I+			I
Ex-i4	2.11582.05.00	FA-ST	F-PA	B1	B1 ⊥	D	D ⊥
Ex-i5	2.11582.06.00	FA-ST	DC-I	B1+			B1
Ex-i6	2.11582.07.00	FA-ST	FA-ST	B2	B2 ⊥	B1	B1 ⊥
Ex-i7	2.11582.08.00	P-SA	F-FF	I ⊥	I	D	D ⊥
Ex-i8	2.11582.09.00	FA-ST	F-FF	B1	B1 ⊥	D	D ⊥

**Possible combinations of the installed MODIS modules for the 100-230 Vac power supply version of the IFC 090i-EEEx**

IFC 090i-EEEx version	Part No.	MODIS modules		Terminal designation			
Ex-i1	2.12253.01.00	P-SA	FA-ST	I ⊥	I	B1	B1 ⊥
Ex-i2	2.12253.02.00	P-SA	F-PA	I ⊥	I	D	D ⊥
Ex-i4	2.12253.03.00	FA-ST	F-PA	B1	B1 ⊥	D	D ⊥
Ex-i6	2.12253.04.00	FA-ST	FA-ST	B2	B2 ⊥	B1	B1 ⊥
Ex-i7	2.12253.05.00	P-SA	F-FF	I ⊥	I	D	D ⊥
Ex-i8	2.12253.06.00	FA-ST	F-FF	B1	B1 ⊥	D	D ⊥

Due to mechanical and electrical limitations, only the listed pairs of MODIS modules are possible. The two modules each use two terminals of the bottom four terminals of the flameproof terminal feed-through in the dividing wall between the electronics and terminal compartment of the signal converter housing, except for the combination with module DC-I (only applicable for 24 Vac/dc versions), where only two of the four terminals are used. Interconnection of the two modules, P-SA with DC-I or FA-ST with DC-I is made internally.

The flameproof terminal feed-through has seven terminals in total, the top two terminals are used for connection of the power supply, the third one is only used for mounting of a metal dividing plate with insulating cover plate. The remaining four are used for the intrinsically safe signal in-/output circuits of the installed MODIS modules.

The metal dividing plate and the insulating cover plate warrant the required separation distances (i.e. clearances, creepage distances and distances through insulation) between the non-intrinsically safe power supply terminals and the intrinsically safe signal in-/output circuits. The insulating cover plate is provided with a sticker that contains important instructions how to remove and re-install the cover plate and the conditions under which it should be established (circuits not live !).

**Important !** Carefully follow the instructions on the sticker that is glued to the top of the insulating cover plate that covers the non-intrinsically safe power supply terminals !

---

For the connection diagrams of the intrinsically safe signal in-/outputs of the installed MODIS modules in the IFC 090i-EEx electronics unit (see next pages). It has to be noted that the intrinsically safe signal in-/outputs may only be connected to the following listed apparatus (registering devices like amp-meters, pulse counters, etc.):

EEx-approved intrinsically safe apparatus;

EEx-approved associated apparatus;

Passive apparatus as defined in your national standard for installation of electrical apparatus in hazardous locations (e.g. EN 60079-14).

Other types of apparatus may only be connected to the intrinsically safe signal in-/outputs through EEx-approved safety barriers, isolating interface units and the like. These barriers or units are not depicted in the connection diagrams for reasons of readability. It is assumed that they are an integrated part of the registering devices or as separate devices connected in series with them. The registering devices may only be installed in the hazardous location if they also have a type of protection for explosion safety according to the European Standards of the EN 500xx series, or if they are constructed as prescribed in your standard national code of practice.

When the intrinsically safe signal in-/outputs are connected to other intrinsically safe or associated apparatus, the maximum safety values (i.e. entity parameters) of all intrinsically safe circuits have to be considered.

<b>Important !</b>	The 100...230 Vac power supply versions of the IFC 090i-EEx signal converter electronics unit with MODIS modules can only be equipped with passive outputs. Therefore the connection diagrams with the numbers 2, 4, 5, 7, 9, 11 and 12 are applicable for the 100...230 Vac power supply versions.
--------------------	---



## Connection diagrams 1 to 4 of the intrinsically safe signal in-/outputs

1 Current output  $I_{active}$

**Version:** Ex-i3

$I = 4 - 20 \text{ mA}$

$R_i = 350 \Omega$

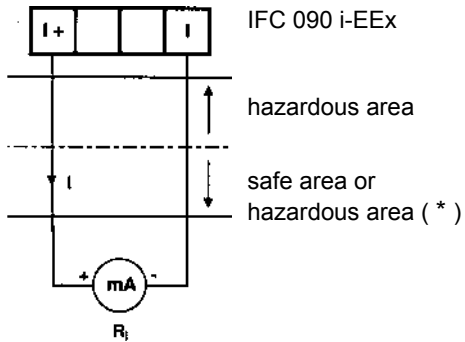

2 Current output  $I_{passive}$

**Versions:** Ex-i1, Ex-i2, Ex-i7

$U_{ext} = 8.1 - 30 \text{ V}$

$I = 4 - 20 \text{ mA}$

$R_i \leq (U_{ext} - 8) / 0.022$

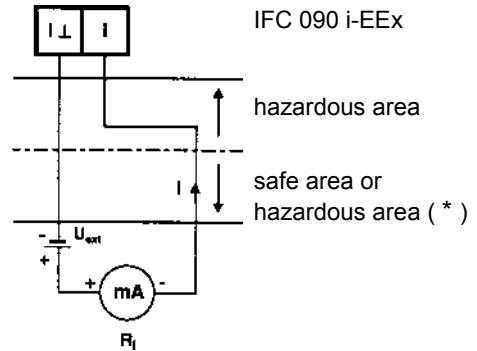

3 Pulse output  $P_{active}$

**Version:** Ex-i5

$U_{int} = 20 \text{ V DC}$

$R_{int} = 260 \Omega$

$U_L = 20 \times R_L / (260 + R_L)$

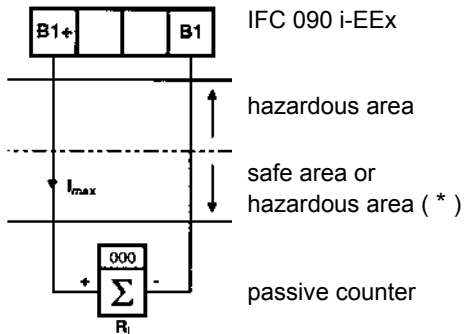

4 Pulse output  $P_{passive}$

**Versions:** Ex-i1, Ex-i4, Ex-i6, Ex-i8

$U_{ext} = 6 - 30 \text{ V DC}$

$I_{max} \leq 110 \text{ mA}$

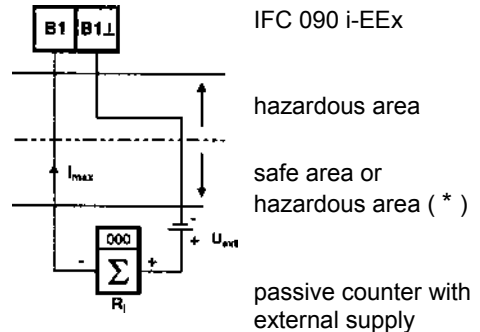

( \* ) Important note: Only if the measuring devices are also explosion protected

**Connection diagrams 5 to 8 of the intrinsically safe signal in-/outputs**

**5** Pulse output  $P_{\text{passive}}$

**Versions:** Ex-i1, Ex-i4, Ex-i6, Ex-i8

$U_{\text{ext}} = 6 - 30 \text{ V}$

$I_{\text{max}} \leq 110 \text{ mA}$

for active EC

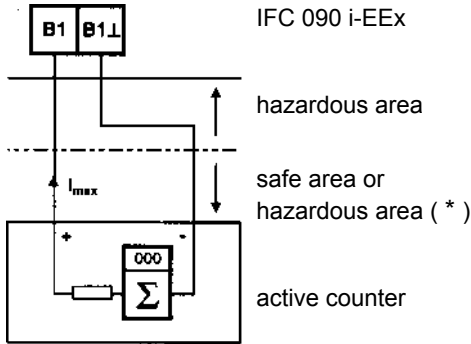

**6** Status output  $S_{\text{active}}$

**Version:**

**Ex-i5**

$U_{\text{int}} = 20 \text{ V DC}$

$R_{\text{int}} = 260 \Omega$

$U_L = 20 \times R_L / (260 + R_L)$

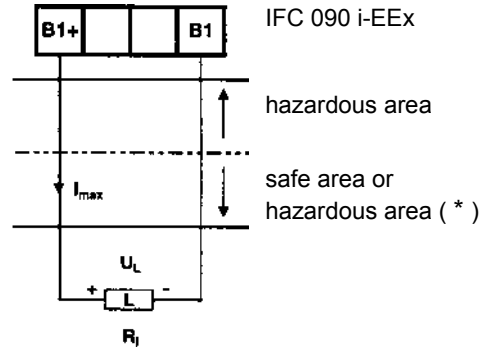

**7** Status output  $S_{\text{passive}}$

**Versions:** Ex-i1, Ex-i4, Ex-i6, Ex-i8

$U_{\text{ext}} = 6 - 30 \text{ V}$

$I_{\text{max}} \leq 110 \text{ mA}$

Connection to terminals B1/B1⊥ and/or

B2/B2⊥

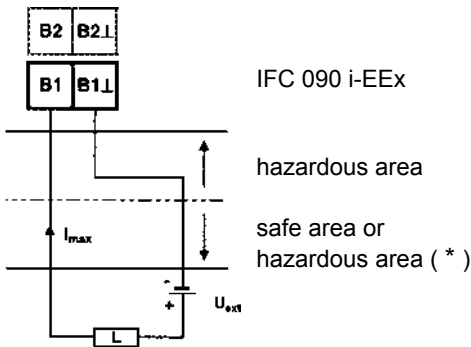

**8** Control input  $C_{\text{active}}$

**Version:** Ex-i5

$U_{\text{int}} = 20 \text{ V DC}$

$I_{\text{contact}} \leq 6 \text{ mA}$

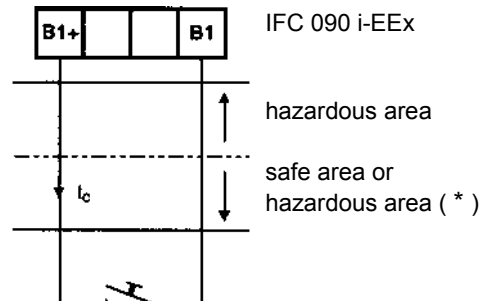

( \* ) Important note: Only if the measuring devices are also explosion protected !

**Connection diagrams 9 to 12 of the intrinsically safe signal in-/outputs**

**9** Control input  $C_{passive}$

**Versions:** Ex-i1, Ex-i4, Ex-i6, Ex-i8  
 $U_{ext} = 7 - 30 \text{ V DC}$   
 Connection to terminals B1/B1 $\perp$  and/or B2/B2 $\perp$

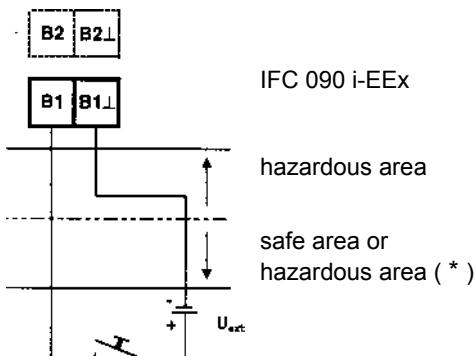

**10** HART active

**Version:** Ex-i3

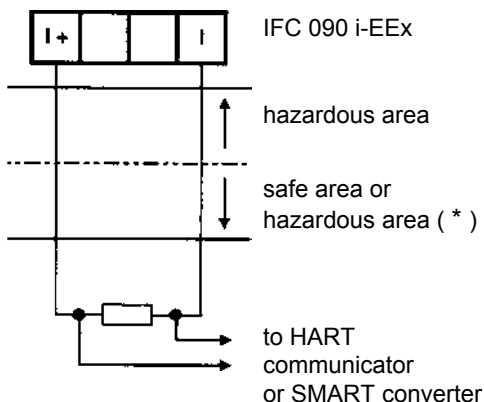

**11** HART passive

**Versions:** Ex-i1, Ex-i2, Ex-i7

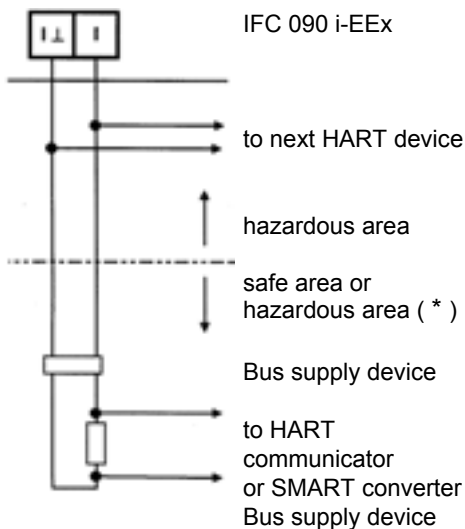

**12** Fieldbus

**Versions:** Ex-i2, Ex-i4, Ex-i7, Ex-i8

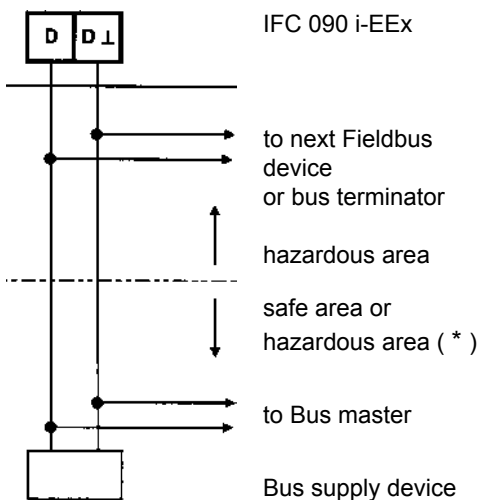

(\* ) Important note: Only if the measuring devices are also explosion protected !

---

### 3 Operation of the signal converter

---

The IFC 090 F/...-EEx signal converter unit is equipped with a display unit that contains magnetic Hall sensors. These Hall sensors enable the settings of the IFC 090...-EEx electronics unit to be set resp. reset with aid of the with the apparatus delivered bar magnet without the necessity to open the flameproof converter housing in the hazardous area.

For the program functions and settings of the converter the standard Installation and operating instructions have to be consulted. It must be noted that - depending on the IFC090 i-EEx version installed - not all output/input functions are available.

Following menus do not apply for the IFC090 i-EEx versions Ex-i2 and Ex-i3:  
(see also Sect. 4.4. "Table of settable functions" in the standard "Installation and operating instructions" of the IFC090 K/F signal converter)

1.01 → VALUE P      1.06 PULS B1      1.06 CONTROL B1      3.02 → VALUE P  
1.06 Output/input B1      1.06 STATUS B1      1.07 CONTROL B2      3.07 HARDWARE  
1.07 Output/input B2      1.07 STATUS B2

Fct.		Text	Description and settings
<b>1.00</b>	<b>1.00</b>	<b>OPERATION</b>	Operations menu
	1.01	FULL SCALE	...
		→ VALUE P	
	1.06	Output/Input B1	
	1.07	Output/Input B2	
	1.06	PULS B1	
	1.06	STATUS B1	
	1.07	STATUS B2	
	1.06	CONTROL B1	
	1.07	CONTROL B2	
<b>3.00</b>	<b>3.00</b>	<b>INSTALL.</b>	Installation menu
	3.02	FLOWMETER	...
		→ VALUE P	
	3.07	HARDWARE	

As a consequence, the chapters included in the standard Installations and operating instructions, giving detailed descriptions of these menus, must be skipped.

---

### 4 Maintenance

---

The IFC 090 F/...-EEx signal converter is maintenance free with regard to the flowmetering properties. Within the scope of the periodical inspections, which are required for electrical apparatus that are installed and used in hazardous classified locations, it is recommended to check the flameproof enclosure on signs of damage or corrosion. This concerns the converter housing.

## 5 Service

See Sect. 6 or contact your (local) KROHNE sales representative for the ordering information of spare parts or replacements of IFC 090...-EEx electronics units and/or power fuses.

### 5.1 General information for replacements

<b>IMPORTANT !</b>	The following instructions must be followed carefully, if the IFC 090/...-EEx signal converter housing has to be opened respectively closed again!
--------------------	--

#### Before opening

Make absolutely sure there is no explosion hazard!

If necessary provide a "Gas-free certificate" !

Make sure that all connecting cables are safely isolated from the power supply !

When the instructions above are strictly followed, the cover (with glass window) of the electronics compartment may be removed. First unscrew the recessed head screw of the interlocking device by a hollow-head screw wrench size 3, until the cover can rotate freely. Unscrew the cover with the special plastic wrench (black) that is supplied with the apparatus.

#### After opening

The copper ground strip at the back of the electronics unit must be securely screwed to the housing (back-end of electronics compartment) by screw SE (see figure below). The electronics unit is screwed into the electronics compartment by two screws D. Before screws SE and D can be accessed, the display unit must be removed via screws A.

Before the cover is screwed back into the housing, the screw-thread must be clean and well-greased with an acid and resin-free grease, e.g. silicone grease.

Screw the cover as tight as possible into the housing by hand, until it cannot be opened by hand anymore. Screw the recessed head screw of the interlocking device tight.

#### IFC 090-EEx electronics unit after removal of display unit

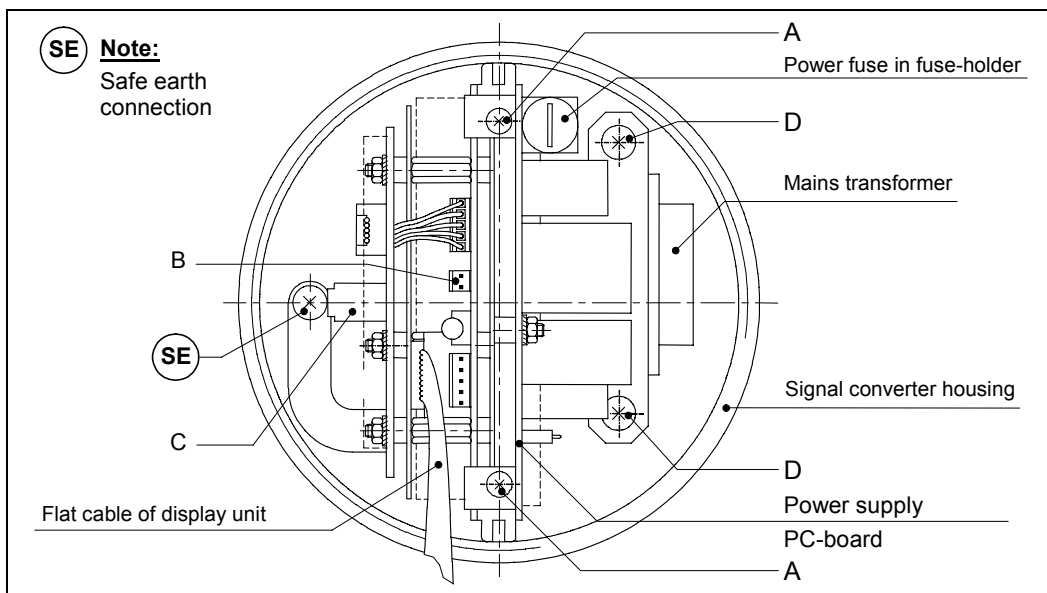

## 5.2 Replacement of electronics unit

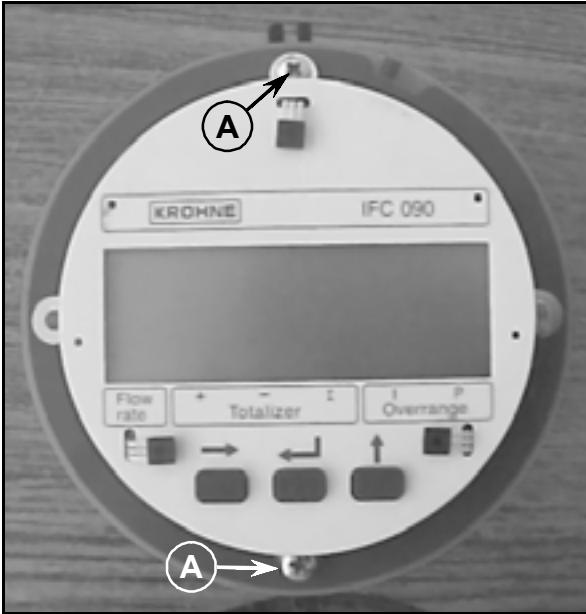

### Display unit of IFC 090...-EEx

Refer to the standard Installation and Operating Instructions for detailed information about resetting and reprogramming the new electronics unit after replacement. The customer specific data (like the value of the internal totalizer) are stored in DATAPROM IC-18, which must be transferred from the "old" to the "new" electronics unit. See Sect. 8.7 of the standard Installation and Operating Instructions for detailed information.

Before commencing work, note the instructions in Sect. 5.1, "Before opening".

#### Then continue as follows:

1. Remove the display cover of the electronics compartment.
2. Unscrew the two screws A (M3) of the display unit (see figure above) and turn it carefully aside.
3. Disconnect the 2-pole field circuit connector (item B in figure on last page) and the 3-pole electrode circuit connector (item C). See figures in Sect. 5.1 and the following.
4. Unscrew the two mounting screws D of the electronics unit and unscrew SE, which fixes the copper ground strip to the back of the housing. A screwdriver with a long shaft ( $\geq 200$  mm) is most suitable for unscrewing screw SE (e.g. screwdriver type Philips No. 2).
5. Carefully remove the electronics unit of the converter housing (see the remark below).
6. Check if the voltage setting (only applicable for AC power supplies) and power fuse rating are correct on the new electronics unit. If necessary, change the voltage setting or replace the power fuse (see Sect. 5.3 and 5.4 of this manual).
7. Carefully insert the electronics unit (keep cables aside, see remark below). Then mount the unit completely into the housing and fix the screws. First the two screws D, then screw SE and reconnect the 2-pole field circuit connector B and the 3-pole electrode circuit connector C to the right counter-plugs on the electronics unit (see figure in Sect. 5.1).
8. Finally screw the display unit back on the frame of the electronics via the two screws A.
9. Screw the cover of the electronics compartment back into the housing.

Note the instructions of Sect. 5.1 ("After opening") during reassembling.

#### IMPORTANT !

Carefully keep the connecting cables of the field coil and electrode circuits to the side of the housing, while removing respectively inserting the electronics unit into the signal converter housing. This is to prevent damaging of the connecting cables!

IFC 090-EEx electronics unit (115/230 Vac version)

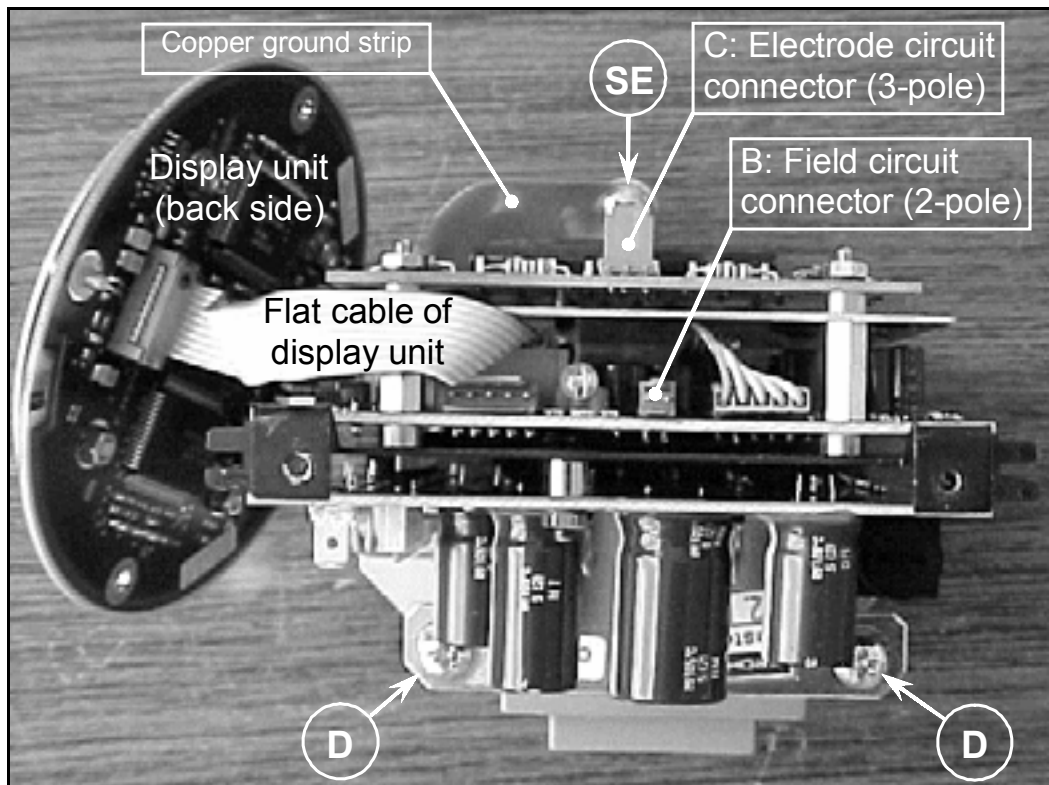

### 5.3 Replacement of power fuse(s)

The power fuse(s) of the different IFC 090...-EEx electronics units (regular or MODIS) have a different rating and are located on slightly different locations on the power supply printed circuit board. Only the power fuse on the 100...230 Vac power supply version of the regular IFC 090-EEx electronics unit can be reached without removing the complete unit out of the housing (only the display unit has to be unscrewed).

#### Regular IFC 090-EEx with 24 Vac/dc power supply

<b>Note:</b>	Before commencing work, read the instructions in Sect. 5.1 ("Before opening"). Then continue as follows:
--------------	--

1. Remove the cover of the electronics compartment.
2. Unscrew the two screws marked with A of the display unit and turn it carefully aside.
3. Disconnect the 2-pole field circuit connector (item B) as well as the 3-pole electrode circuit connector (item C). See figures in Sect.5.1 and 5.2.
4. Unscrew the two mounting screws D of the electronics unit and screw SE, which fixes the copper ground strip to the integrated aluminum dividing wall at the back of the electronics compartment. Use a screwdriver with a long shaft ( $\geq 200$  mm) like type Philips No. 2 for screw SE. Then take out the electronics unit, but be careful with the connecting cables, so that they do not get damaged.
5. The defective power fuse(s) F1 and/or F2 (see following figure) can be replaced now. The 24 Vac/dc power supply uses two sub-miniature fuses type TR 5 that are rated T1.25 A in accordance with IEC 127-3 publication (part No. 5.09080.00.00).
6. Reassemble in reverse order (points 3 through 1).

<b>Note:</b>	Read the instructions of Sect. 5.1 ("After opening") during reassembling.
--------------	---

IFC 090-EEx electronics unit with 24 Vac/dc power supply

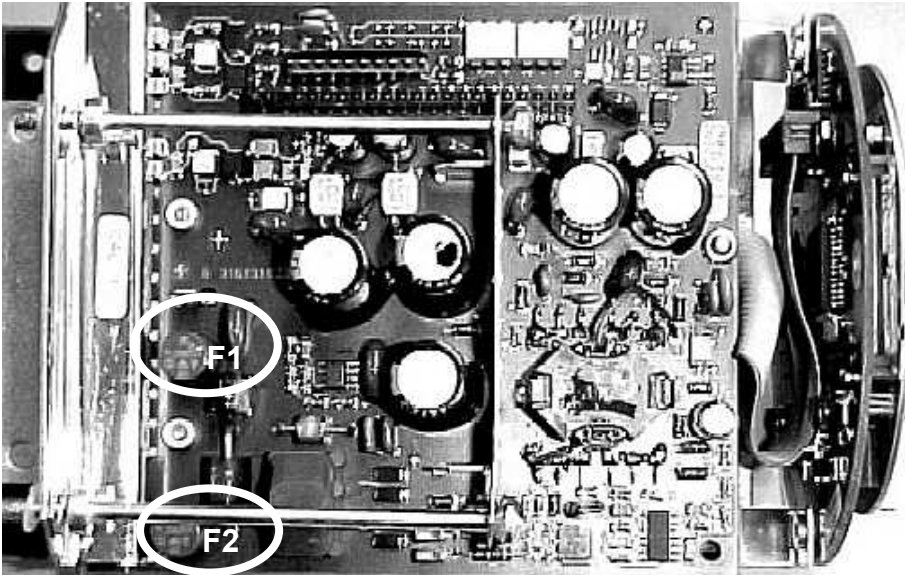

F1 and F2 fuses of power supply



## Regular IFC 090-EEEx with 100...230 Vac power supply

**Note:** Before commencing work, read the instructions in Sect. 5.1 ("Before opening"). Then continue as follows:

1. Remove the cover of the electronics compartment
2. Unscrew the two screws A of the display unit and turn the display unit carefully aside.
3. The fuse-holder, in which the power fuse in accordance with IEC 127-2 size  $\varnothing 5 \times 20$  mm is mounted, is now accessible to replace the defect power fuse F1 by a new fuse with the same rating. The rating depends on the voltage setting of the power supply unit. The power supply of 100/115 Vac requires a fuse of T200mA (part No. 5.05678.00.00) and the 200/230 Vac requires a fuse of T125 mA (part No. 5.06627.00.00).

The fuse rating is also shown by the yellow sticker that is glued on the mains transformer, which can only be seen after the regular IFC 090-EEEx electronics unit is completely removed from the flameproof signal converter housing. See the next figure.

**NOTE:** In case of any doubt about the fuse rating or the voltage setting of the unit, remove the complete unit from the housing as described in Sect. 5.2 and check in the following figure depicted items. Change when needed !

4. Reassemble the unit in reverse order (points 2 and 1).

**Note** Read the instructions of Sect. 5.1 ("After opening") during reassembling.

### Power supply version 115/230 Vac

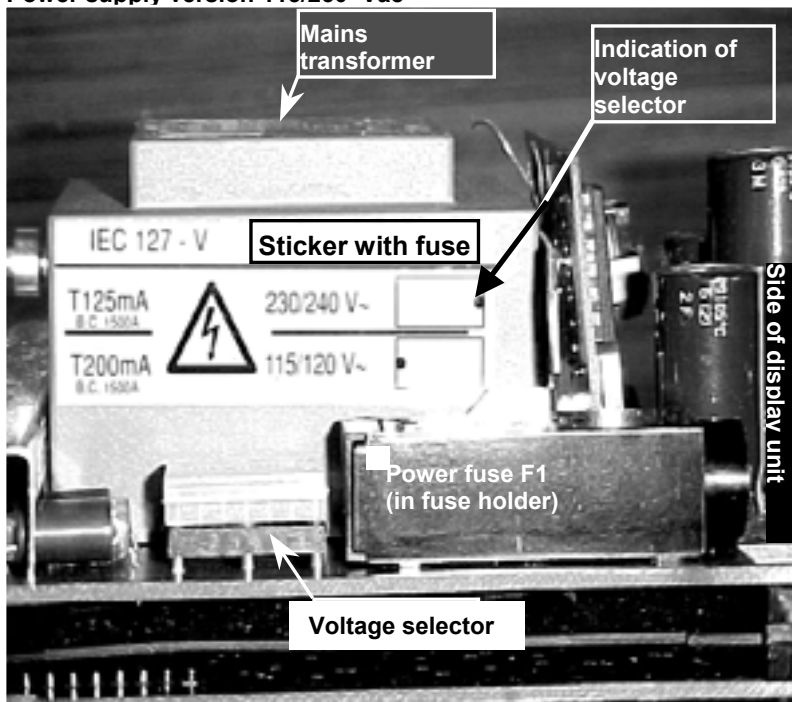

## MODIS version IFC 090i-EEx

**Note:** Before commencing work, read the instructions in Sect. 5.1 ("Before opening"). Then continue as follows:

1. Remove the cover of the electronics compartment
2. Unscrew the two screws A of the display unit and turn it carefully aside.
3. Disconnect the 2-pole field circuit connector (item B) and the 3-pole electrode circuit connector (item C). See figures in Sect. 5.1 and 5.2 for details.
4. Unscrew the two screws D and screw SE by a screwdriver with a long shaft (200 mm). Take out the electronics unit, but do not damage the connecting cables. See the note **IMPORTANT**.
5. The defective power fuse (see following figure) can be replaced now. Use a fuse rated at T1.25H250V (part No. 5.06232.00.00) for the 24 Vac/dc power supply and a fuse rated at T1.6H250V (Part No. 5.07823.00.00) for the 100...230 Vac power supply. Note that the locations are slightly different (the 24 Vac/dc supply version is shown).
6. Reassemble in reverse order (points 4 through 1).

**Note:** Read the instructions of Sect. 5.1 ("After opening") during reassembling

**Important!** Carefully keep the connecting cables of the field coil and electrode circuits to the side of the housing, while removing or inserting the electronics unit into the signal converter housing. This is to prevent damaging of the connecting cables!

### IFC 090i-EEx electronics unit (24 Vac/dc version is shown)

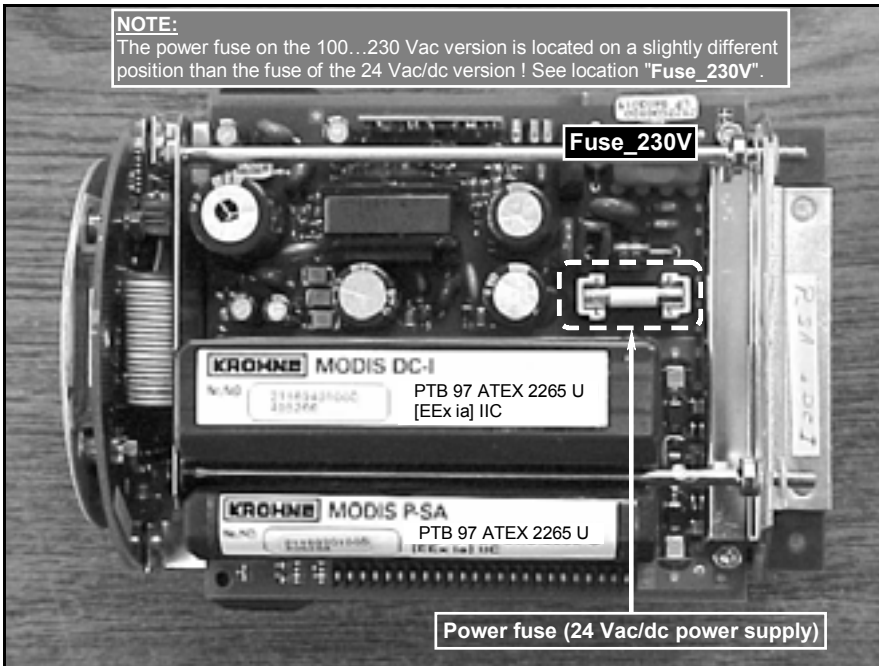

---

#### 5.4 Changing power supply voltage

This only applies to the regular IFC 090-EEx electronics unit with 100-230 Vac power supply.

<b>Note:</b>	Before commencing work, read the instructions in Sect. 5.1 ("Before opening"). Then continue as follows:
--------------	--

1. Remove the cover of the electronics compartment.
2. Unscrew the two screws A of the display unit and turn the display unit carefully aside.
3. Unscrew the two mounting screws D of the electronics unit and screw SE, which fixes the copper ground strip at the back of the housing. A screwdriver with a long shaft (200 mm) can best be used to unscrew SE (screwdriver type Philips No. 2).
4. Disconnect the 2-pole and 3-pole connectors and carefully remove the electronics unit.
5. The voltage setting of the power supply can be changed by turning the dummy dual-in-line block (i.e. voltage selector, see last figure in Sect. 5.3) over 180° in its socket. The position of the notch on the dummy dual-in-line block indicates the voltage setting. Also see the sticker that is glued on the mains transformer.
6. Reassemble in reverse order (points 4 through 1).
7. Screw the cover of the electronics compartment back into the housing.

<b>Note:</b>	Note the instructions of Sect. 5.1 ("After opening") during reassembling.
--------------	---

<b>IMPORTANT!</b>	Carefully keep the connecting cables of the field coil and electrode circuits to the side of the housing, while inserting the electronics unit into respectively removing it from the signal converter housing. This is to prevent damaging of the connecting cables!
-------------------	---

## 6 Ordering information

In case of questions about spare or replacing parts contact your local Krohne representative. The part numbers of the several parts are listed in the sections below.

### 6.1 Regular IFC 090-EEx electronics unit

The table below shows the regular (non-MODIS) IFC 090-EEx versions available with the possible power supply units and the accompanying power fuse(s).

IFC 090-EEx electronics unit		Power fuse(s)			
Power supply	Part No.	Symbol	Type	Rating	Part No.
230/240 Vac	2.10664.10.00	F1	G-fuse Ø5x20 1500A @ 250V	125 mA T	5.06627.00.00
115/120 Vac		F1		200 mA T	5.05678.00.00
200 Vac	2.10664.13.00	F1		125 mA T	5.06627.00.00
100 Vac		F1		200 mA T	5.05678.00.00
24 Vac/dc	2.10665.10.00	F1 + F2	TR5, 35A @ 250V	1.25 A T	5.09080.00.00

### 6.2 MODIS version IFC 090i-EEx electronics unit

The following table gives a summary of the IFC 090i-EEx electronics units available (MODIS version) and the matching part number. These IFC 090i-EEx electronics units are either provided with a 24 Vac/dc power supply or a 100...230 Vac power supply.

Version	MODIS modules		Part number	
	Position A	Position B	24 Vac/dc power supply	100...230 Vac power supply
Ex-i1	P-SA	FA-ST	2.11582.01.00	2.12253.01.00
Ex-i2	P-SA	F-PA	2.11582.03.00	2.12253.02.00
Ex-i3	P-SA	DC-I	2.11582.02.00	not available
Ex-i4	FA-ST	F-PA	2.11582.05.00	2.12253.03.00
Ex-i5	FA-ST	DC-I	2.11582.06.00	not available
Ex-i6	FA-ST	FA-ST	2.11582.07.00	2.12253.04.00
Ex-i7	P-SA	F-FF	2.11582.08.00	2.12253.05.00
Ex-i8	FA-ST	F-FF	2.11582.09.00	2.12253.06.00

The following table below lists the accompanying power fuse.

Power supply version	Power fuse for IFC 090i-EEx electronics units		
	Type	Rating	Part number
24 Vac/dc	G-fuse Ø5x20 1500A @ 250V	1.25 A T (T1.25H250V)	5.06232.00.00
100...230 Vac	G-fuse Ø5x20 1500A @ 250V	1.6 A T (T1.6H250V)	5.07823.00.00

<b>Notes:</b>	All G-fuses listed comply with IEC 127-2. They are Ø5 x 20 mm in size and blow at 1500 A at 250 V .
---------------	---

Fuse type TR5 is sub-miniature and blows at 35 A at 250 V. It, too, complies with IEC 127-3. The regular IFC 090-EEx electronics unit with 24 Vac/dc power supply contains two of these fuses in the primary circuits, labelled as F1 and F2.

**KROHNE**

Altometer

### EC Declaration of Conformity

We,

KROHNE Altometer  
Kerkestraat 12  
3313 LC Dordrecht  
The Netherlands

Declare under our sole responsibility that the products

Signal converter types

**IFC 090 F-EEEx and  
IFC 090 F/i-EEEx**

Fulfill the requirements of following EC directives:

- ATEX Directive 94/9/EC
- EMC Directive 89/336/EC

The IFC 090 F-EEEx and IFC 090 F/i-EEEx signal converters are designed and manufactured conform following harmonized standards:

- EN 50 014 : 1997
- EN 50 018 : 2000
- EN 50 019 : 2000
- EN 50 020 : 1994
- EN 50 281-1-1 : 1998
  
- EN 50 081-1
- EN 50 082-2
- EN 61 010-1

The IFC 090 F-EEEx and IFC 090 F/i-EEEx signal converters are examined and type-approved under EC-Examination certificate KEMA 01 ATEX 2234. The KROHNE Altometer quality assurance system is approved by KEMA Registered Quality b.v.

Dordrecht, 26.03.2002



L. Umker  
(General Manager)

**KEMA** 



**(1) EC-TYPE EXAMINATION CERTIFICATE**

(2) Equipment or protective system intended for use in potentially explosive atmospheres – Directive 94/9/EC

(3) EC-Type Examination Certificate Number: **KEMA 01ATEX2234**

(4) Equipment or protective system: **Electromagnetic signal converter, types IFC 090 F-EEx, IFC 090 Fi-EEx, MGC 090 F-EEx and MGC 090 Fi-EEx**

(5) **Manufacturer: Krohne Altometer**

(6) **Address: Kerkplaat 12, 3313 LC Dordrecht, The Netherlands**

(7) This equipment or protective system and any acceptable variation thereto is specified in the schedule to this certificate and the documents therein referred to.

(8) KEMA Quality B.V., notified body number 0344 in accordance with Article 9 of the Council Directive 94/9/EC of 23 March 1994, certifies that this equipment or protective system has been found to comply with the Essential Health and Safety Requirements relating to the design and construction of equipment and protective systems intended for use in potentially explosive atmospheres given in Annex II to the Directive.

The examination and test results are recorded in confidential report no. 2016361.

(9) Compliance with the Essential Health and Safety Requirements has been assured by compliance with:

<b>EN 50014 : 1997</b>	<b>EN 50018 : 2000</b>	<b>EN 50019 : 2000</b>
<b>EN 50020 : 1994</b>	<b>EN 50281-1-1 : 1998</b>	

(10) If the sign "X" is placed after the certificate number, it indicates that the equipment or protective system is subject to special conditions for safe use specified in the schedule to this certificate.

(11) This EC-Type Examination Certificate relates only to the design, examination and tests of the specified equipment or protective system in accordance with the Directive 94/9/EC. Further requirements of the Directive apply to the manufacturing process and supply of this equipment or protective system. These are not covered by this certificate.

(12) The marking of the equipment or protective system shall include the following:

 **II 2 GD EEx de [ib] IC T6 or EEx de [ib] [ia] IC T6**  
**T85 °C**

Amhem, 25 January 2002.

KEMA Quality B.V.



T. Pipker  
Certification Manager

\* This Certificate may only be reproduced in its entirety and without any change.

KEMA Quality B.V.  
Ulrechtseweg 316, 6812 AR Amhem, The Netherlands  
P.O. Box 9186, 6802 EC Amhem, The Netherlands  
Telephone +31 26 3 56 20 06, Telex +31 26 3 52 58 00

ACCREDITED BY THE  
DUTCH COUNCIL FOR  
ACCREDITATION



Page 1/5

(13)

## SCHEDULE

(14)

to EC-Type Examination Certificate KEMA 01ATEX2234

(15) **Description**

The Electromagnetic signal converter, types IFC 090 F-EEEx, IFC 090 F/i-EEEx, MGC 090 F-EEEx and MGC 090 F/i-EEEx, when connected to a suitable certified flowmeter primary head, is used for measuring, counting and displaying the linear flow of an electrical conductive liquid. The signal converter unit supplies power to the field coils of a remote primary head and processes the electrical measurement signal.

Within the flameproof signal converter housing various modules are fitted, some models contain intrinsically safe circuits for connection to external circuits as specified below.

Ambient temperature range -20 °C ... +60 °C (for signal converter with electronics unit type IFC090i).

Ambient temperature range -40 °C ... +60 °C (for signal converter with electronics unit type IFC090).

The maximum surface temperature T85 °C is based on an ambient temperature of 60 °C.

### Electrical data

#### IFC 090 F-EEEx / MGC 090 F-EEEx

Power supply ..... 100/200 Vac, 115/230 Vac, -15/+10 %, 13 VA  
24 Vdc -25/+30 %, 24 Vac -15/+10 %, 8 W  
 $U_m = 253$  V

Signal I/O's .....  $\leq 38$  Vdc

Field coil circuit ..... For connection to associated certified primary head:  
 $U \leq 40$  V (pulsed)  
 $I \leq 160$  mA (fuse protected)

Electrodes circuit ..... In type of explosion protection intrinsic safety  
EEEx ib IIC, with the following maximum values:

$$\begin{aligned} U_o &= 9,0 \text{ V} \\ I_o &= 38 \text{ mA} \\ P_o &= 34 \text{ mW} \end{aligned}$$

Maximum allowed external capacitance  $C_o = 4,9 \mu\text{F}$ ,  
maximum allowed external inductance  $L_o = 23$  mH.

#### IFC 090 F/i-EEEx / MGC 090 F/i-EEEx

Power supply ..... 100... 230 Vac -15/+10 %, 15 VA  
24 Vdc -25/+30 %, 24 Vac -15/+10 %, 10 W  
 $U_m = 253$  V

Field coil circuit ..... For connection to associated certified primary head:  
 $U \leq 40$  V (pulsed)  
 $I \leq 160$  mA (fuse protected)

(13)

## SCHEDULE

(14)

to EC-Type Examination Certificate KEMA 01ATEX2234

### Electrical data (continued)

Electrodes circuit ... .. in type of explosion protection intrinsic safety  
EEx ib IIC, with the following maximum values:

$$\begin{aligned} U_o &= 9,0 \text{ V} \\ I_o &= 38 \text{ mA} \\ P_o &= 34 \text{ mW} \end{aligned}$$

Maximum allowed external capacitance  $C_o = 4,9 \mu\text{F}$ ,  
maximum allowed external inductance  $L_o = 23 \text{ mH}$ .

### Signal circuit

Modules P-SA and FA-ST ..... in type of explosion protection intrinsic safety EEx ia IIC,  
only for connection to a certified intrinsically safe circuit in  
type of explosion protection intrinsic safety  
EEx ia IIC or EEx ia IIB or  
EEx ib IIC or EEx ib IIB,  
with the following maximum values

$$\begin{aligned} U_i &= 30 \text{ V} \\ I_i &= 250 \text{ mA} \\ P_i &= 1,0 \text{ W} \end{aligned}$$

The effective internal capacitance  $C_i = 5 \text{ nF}$ ,  
the effective internal inductance  $L_i$  is negligibly small.

### Signal circuit

Modules F-PA and F-FF ..... in type of explosion protection intrinsic safety EEx ia IIC,  
only for connection to a certified intrinsically safe circuit  
(for instance a Supply of the FISCO Model in accordance  
with document CLC/SC31-3(SEC)155 of Dec. 2000) in  
type of explosion protection intrinsic safety  
EEx ia IIC or EEx ia IIB or  
EEx ib IIC or EEx ib IIB,  
with the following maximum values

$$\begin{aligned} U_i &= 30 \text{ V} \\ I_i &= 300 \text{ mA} \\ P_i &= 4,2 \text{ W} \end{aligned}$$

The effective internal capacitance  $C_i = 5 \text{ nF}$ ,  
the effective internal inductance  $L_i$  is negligibly small.

### Signal/supply circuit

Module DC-1 ... .. in type of explosion protection intrinsic safety EEx ia IIC,  
(24 Vac/dc version only) with the following maximum values:

$$\begin{aligned} U_o &= 23,5 \text{ V} \\ I_o &= 98 \text{ mA} \\ P_o &= 0,6 \text{ W} \end{aligned}$$

Maximum allowed external capacitance  $C_o = 127 \text{ nF}$ ,  
maximum allowed external inductance  $L_o = 4 \text{ mH}$ .

Only for connection to certified intrinsically safe circuits  
in type of explosion protection EEx ia IIC or EEx ia IIB or  
EEx ib IIC or EEx ib IIB without supply (passive).

Page 3/5



(13) **SCHEDULE**  
(14) **to EC-Type Examination Certificate KEMA 01ATEX2234**

**Electrical data (continued)**

The applicable type of explosion protection of the aforementioned intrinsically safe circuits EEx ia IIC is determined by the type of protection of the intrinsically safe circuit which is connected to it, respectively EEx ia IIB or EEx ib IIC or EEx ib IIB.

The aforementioned intrinsically safe circuits shall, from the safety point of view, be considered to be connected to ground.

**Installation instructions**

For use in potentially explosive atmospheres of flammable gases, fluids or vapours:  
The cable entry device shall be in type of protection flameproof enclosure "d" for the terminal compartment in type of protection flameproof enclosure "d" or increased safety "c" for the terminal compartment in type of protection increased safety "e", suitable for the conditions of use and correctly installed.

For use in the presence of combustible dust:  
The cable entry device shall be in type of equipment Category II 2 D, suitable for the conditions of use and correctly installed.

Unused openings shall be closed with suitable certified closing elements.

With the use of conduit, a suitable certified sealing device such as a stopping box with setting compound shall be provided immediately at the entrance to the flameproof enclosure.

**Routine tests**

Routine tests according to EN 50018, Clause 16 are not required since the type test has been made at a static pressure of four times the reference pressure.

Each signal converter shall withstand a test voltage according to EN 50019, Clause 6.1, of 500 V during one minute without breakdown between the field coils circuit and the enclosure

- (16) **Report**  
KEMA No. 2016361.
- (17) **Special conditions for safe use**  
None.
- (18) **Essential Health and Safety Requirements**  
Covered by the standards listed at (9)

(13)

## SCHEDULE

(14)

to EC-Type Examination Certificate KEMA 01ATEX2234

(19) **Test documentation**

1. Component Certificate KEMA No. Ex-99.E.8128 U  
PTB No. Ex-98.E.1048 U  
KEMA No. Ex-01.E.2036 U  
Certificate of Conformity KEMA No. Ex-97.D.2241  
EC-Type Examination Certificate PTB 98 ATEX 2012 U

dated

2. Description (14 pages) 05.04.2001, 10.12.2001,  
14.12.2001, 19.12.2001  
and 18.01.2002
3. Drawings index sheet 18.01.2002

---

## Notice

<http://www.krohne.com>

Production

**KROHNE**

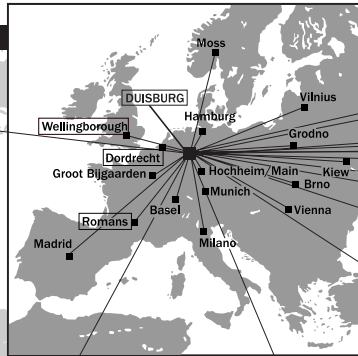

#### Australia

KROHNE Australia Pty Ltd.  
Unit 19 No. 9, Hudson Ave.  
Castle Hill 2154, NSW  
TEL: +61(0)2-98948711  
FAX: +61(0)2-98948555  
e-mail: [krohne@krohne.com.au](mailto:krohne@krohne.com.au)

#### Austria

KROHNE Austria Ges.m.b.H.  
Modocenterstraße 14  
A-1030 Wien  
TEL: +43(0)1/203 45 32  
FAX: +43(0)1/203 47 78  
e-mail: [info@krohne.at](mailto:info@krohne.at)

#### Belgium

KROHNE Belgium N.V.  
Brusselstraat 320  
B-1702 Groot Bilgaarden  
TEL: +32(0)2-4 66 00 10  
FAX: +32(0)2-4 66 08 00  
e-mail: [krohne@krohne.be](mailto:krohne@krohne.be)

#### Brazil

KROHNE Conaut  
Controltes Automaticos Ltda.  
Estrada Das Águas Espraiadas, 230 C.P. 56  
06835 - 080 EMBU - SP  
TEL: +55(0)11-4785-2700  
FAX: +55(0)11-4785-2768  
e-mail: [conaut@conaut.com.br](mailto:conaut@conaut.com.br)

#### China

KROHNE Measurement Instruments Co. Ltd.  
Room 7E, Yi Dian Mansion  
746 Zhao Jia Bang Road  
Shanghai 200030  
TEL: +86(0)21-64677163  
FAX: +86(0)21-64677166  
Cellphone: +86(0)139 1885890  
e-mail: [info@krohne-asia.com](mailto:info@krohne-asia.com)

#### CIS

Kanex KROHNE Engineering AG  
Business-Centre Planeta, Office 403  
ul. Manistkaja 3  
109147 Moscow/Russia  
TEL: +7(0)95-9117165  
FAX: +7(0)95-9117231  
e-mail: [krohne@dol.ru](mailto:krohne@dol.ru)

#### Czech Republic

KROHNE CZ, spol. s r.o.  
Soběšická 156  
CZ-63800 Brno  
TEL: +420 545 532 111  
FAX: +420 545 220 093  
e-mail: [brno@krohne.cz](mailto:brno@krohne.cz)

#### France

KROHNE S.A.S.  
Usine des Ors  
BP 98  
F-26 103 Romans Cedex  
TEL: +33(0)4 75 05 44 00  
FAX: +33(0)4 75 05 00 48  
e-mail: [info@krohne.fr](mailto:info@krohne.fr)

#### Germany

KROHNE Messtechnik  
GmbH & Co. KG  
Ludwig-Krohne-Straße  
D-47058 Duisburg  
TEL: +49(0)203-301-0  
FAX: +49(0)203-301 389  
e-mail: [krohne@krohne.de](mailto:krohne@krohne.de)

#### India

KROHNE Marshall Ltd.  
A-34/35, M.I.D.C.  
Industrial Area, H-Block,  
Pimpri Poona 411018  
TEL: +91(0)20-744 20 20  
FAX: +91(0)20-744 20 40  
e-mail: [pcu@snl.net](mailto:pcu@snl.net)

#### Italy

KROHNE Italia Srl.  
Via V. Monti 75  
I-20145 Milano  
TEL: +39(0)2-4 30 06 61  
FAX: +39(0)2-43 00 66 66  
e-mail: [krohne@krohne.it](mailto:krohne@krohne.it)

#### Korea

Hankuk KROHNE  
2 F, 599-1  
Banghwa-2-Dong  
Kangseo-Ku  
Seoul  
TEL: +82(0)2665-85 23-4  
FAX: +82(0)2665-85 25  
e-mail: [flwotech@unitel.co.kr](mailto:flwotech@unitel.co.kr)

#### Netherlands

KROHNE Altometer  
Kerkeplaat 12  
NL-3313 LC Dordrecht  
TEL: +31(0)78-6306300  
FAX: +31(0)78-6306390  
e-mail: [postmaster@krohne-altometer.nl](mailto:postmaster@krohne-altometer.nl)

#### KROHNE Nederland B.V.

Kerkeplaat 12  
NL-3313 LC Dordrecht  
TEL: +31(0)78-6306200  
FAX: +31(0)78-6306405  
Service Direkt: +31(0)78-6306222  
e-mail: [info@krohne.nl](mailto:info@krohne.nl)

#### Norway

KROHNE Instrumentation A.S.  
Ekholtsveien 114  
NO-1526 Moss  
P.O. Box 2178, NO-1521 Moss  
TEL: +47(0)69-264860  
FAX: +47(0)69-267333  
e-mail: [postmaster@krohne.no](mailto:postmaster@krohne.no)  
Internet: [www.krohne.no](http://www.krohne.no)

#### South Africa

KROHNE Pty. Ltd.  
163 New Road  
Halfway House Ext. 13  
Midrand  
TEL: +27(0)11-315-2685  
FAX: +27(0)11-805-0531  
e-mail: [midrand@krohne.co.za](mailto:midrand@krohne.co.za)

#### Spain

I.L. KROHNE Iberia, S.r.L.  
Poligono Industrial Nilo  
Calle Brasil, n.º 5  
E-28806 Alcalá de Henares-Madrid  
TEL: +34(0)91-8 83 21 52  
FAX: +34(0)91-8 83 48 54  
e-mail: [krohne@krohne.es](mailto:krohne@krohne.es)

#### Switzerland

KROHNE AG  
Llferstr. 90  
CH-4019 Basel  
TEL: +41(0)61-638 30 30  
FAX: +41(0)61-638 30 40  
e-mail: [info@krohne.ch](mailto:info@krohne.ch)

#### United Kingdom

KROHNE Ltd.  
Rutherford Drive  
Park Farm Industrial Estate  
Wellingsborough,  
Northants NN8 6AE, UK  
TEL: +44(0)19 33-408 500  
FAX: +44(0)19 33-408 501  
e-mail: [info@krohne.co.uk](mailto:info@krohne.co.uk)

#### USA

KROHNE Inc.  
7 Dearborn Road  
Peabody, MA 01960  
TEL: +1-978 535-6060  
FAX: +1-978 535-1720  
e-mail: [info@krohne.com](mailto:info@krohne.com)

#### Overseas Representatives

Algeria	Japan
Argentina	Jordan
Bulgaria	Kuwait
Cameroon	Morocco
Canada	Mauritius
Chile	Mexico
Columbia	New Zealand
Croatia	Pakistan
Denmark	Poland
Ecuador	Portugal
Egypt	Saudi Arabia
Finland	Senegal
French Antilles	Singapore
Greece	Slovakia
Guinea	Slovenia
Hong Kong	Sweden
Hungary	Taiwan
Indonesia	Thailand
Ivory Coast	Turkey
Iran	Tunisia
Ireland	Venezuela
Israel	Yugoslavia

#### Other Countries:

KROHNE Messtechnik  
GmbH & Co. KG  
Ludwig-Krohne-Str.  
D-47058 Duisburg  
TEL: +49(0)203-301 309  
FAX: +49(0)203-301 389  
e-mail: [export@krohne.de](mailto:export@krohne.de)