

**Addition to the
installation and operating instructions**

ALTOFLUX 2W IFM 4042 K/EEx

**2-wire compact
electromagnetic flowmeter**

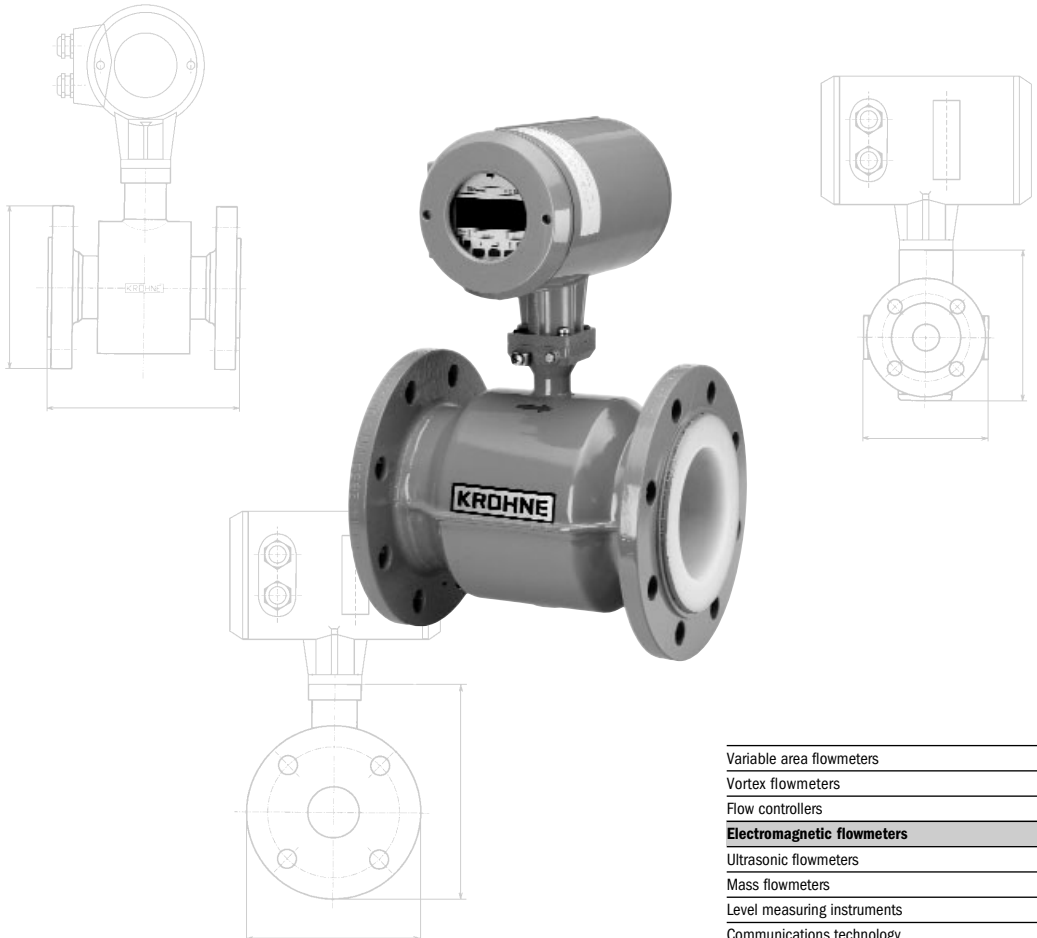

Variable area flowmeters

Vortex flowmeters

Flow controllers

Electromagnetic flowmeters

Ultrasonic flowmeters

Mass flowmeters

Level measuring instruments

Communications technology

Engineering systems & solutions

Switches, counters, displays and recorders

Heat metering

Pressure and temperature

Warning!

- No safety technical changes may be made to the devices. Unauthorized changes might affect the explosion safety of the devices.
- These additional instructions are an extension to the Installation and Operating Instructions and only applies for the EEx version of the IFM 4042 K magnetic-inductive compact flowmeter. All technical information described in the Installation and Operating Instructions are applicable, when not specifically excluded or replaced by the instructions in these additional instructions.

Contents

1	System components	3
1.1	General information	3
1.2	Data plates	4
1.3	Primary head	4
1.4	IFC 040-EEx signal converter	5
1.4.1	Electronics compartment	5
1.4.2	Terminal compartment	5
1.5	Cable or conduit entries	5
2	Electrical connection	6
2.1	Equipotential bonding system	6
2.2	Terminal arrangement	6
2.3	Description of the output circuits	6
2.4	Connection diagram	8
2.5	Safety-technical data	9
2.6	Connection examples	9
2.6.1	Example of IFM 4042 K in 2-wire mode	9
2.6.2	Example of IFM 4042 K in 2×2-wire mode (4-wire)	10
3	Operation of the signal converter	11
4	Maintenance	11
5	Ordering information	11
6	Technical data	11
7	Replacement of electronic unit	12
7.1	Removal of the electronics unit	12
7.2	Insertion of the electronics unit	12
8	EC Declaration of conformity	13
9	EC-Type examination certificate	14

Be sure to follow these instructions!

Important!

- The prescriptions and regulations as well as the electrical data described in the EC-type examination certificate must be obeyed.
- Beside the instructions for electrical installations in non-hazardous locations according to the applicable national standard (equivalent of IEC 364, e.g. VDE 0100), especially the regulations in EN 60079-14 "Electrical installations in hazardous locations" or equivalent national standard must be followed.
- Installation, establishment, utilization and maintenance are only allowed to be executed by personnel with an education in explosion safety!

1 System components

1.1 General information

General information The Altoflux 2W IFM 4042 K-EEEx electromagnetic compact flowmeter in 2-wire technology is in accordance with European Directive 94/9/EC (ATEX 100a) and approved for hazardous classified locations of Zone 1 and 2 under:

KEMA 01 ATEX 2200 X

The IFM 4042 K-EEEx compact flowmeter is designed for ambient temperatures in the range of -40°C up to +60°C.

The allowed process liquid temperature is a.o. limited by the combustible atmosphere that (possibly) surrounds the apparatus, which again is determined by the temperature class of the atmosphere (first column of the tables). See tables below for details.

For dusts the second column of the two below listed tables is applicable.

Temperature classification DN 25 - 150 with PFA liner

Temperature class (for gases)	Max. surface temperature (for dusts)	Maximum process liquid temperature		
		T _a ≤ 40°C	T _a ≤ 50°C	T _a ≤ 60°C
T6	T85°C	70°C	70°C	70°C
T5	T100°C	85°C	85°C	85°C
T4	T135°C	120°C	120°C	115°C
T3	T180°C	180°C	180°C	115°C
Use heat-resistant cables		no	no	yes

Temperature classification DN 10 - 20 and >DN 200

Temperature class (for gases)	Max. surface temperature (for dusts)	Maximum process liquid temperature		
		T _a ≤ 40°C	T _a ≤ 50°C	T _a ≤ 60°C
T6	T85°C	75°C	70°C	70°C
T5	T100°C	95°C	90°C	75°C
T4	T135°C	130°C	115°C	75°C
T3	T180°C *	150°C	115°C	75°C

* T 150 °C for DN 10-20 and > DN 200





The IFM 4042 K-EEEx flowmeter consists of the IFC 040-EEEx signal converter unit, which is screwed on top of the primary head (i.e. the measuring unit). The compact flowmeter is marked with one of the codes below, depending on the meter size:

- **DN 10 - 20** II 2GD EEx dme [ib] IIC T6...T3 ("EEEx e and d" terminal compartment)
- **DN 25 - 150** II 2GD EEx de [ib] IIC T6...T3 ("EEEx e and d" terminal compartment)
- **DN 200 - 300** II 2GD EEx dqe [ib] IIC T6...T3 ("EEEx e and d" terminal compartment)
- **DN 350 and up** II 2GD EEx de [ib] IIC T6...T3 ("EEEx e" and "EEEx d" terminal compartment)





For details see the EC-type examination certificate in Section 9 of these instructions.

1.2 Data plates

IFM 4042 K-EEx, type "EEx de [ib]"

 Kerkeplaat 12 3313 LC Dordrecht The Netherlands		 
Altometer		
TYPE	IFM 4042 K-EEx	YEAR OF PRODUCTION
		2002
	KEMA 01 ATEX 2200 X	
	II 2GD EEx d [] e [ib] IIC T6...T3	IP65/67
AMBIENT TEMPERATURE: -40...+60°C.		T85...180°C
SEE CERTIFICATE FOR MAXIMUM TEMPERATURES.		
SERIAL NO. <input type="text"/>		
DO NOT OPEN ENCLOSURE WHEN ENERGIZED ! WAITING TIME BEFORE OPENING OF THE FLAMEPROOF ENCLOSURE: T6 ≥ 20 MIN.; T5 ≥ 11 MIN. MAX. SHORT-CIRCUIT CURRENT OF MAINS <input type="text"/> A		
Electrode circuit: only internal connections EEx ib IIC Signal in-/outputs are possible in type of protection Intrinsic safety (EEx ib), Increased safety (EEx e) or Flameproof enclosure (EEx d). Consult manual !		
<u>Circuits</u>	<u>Function</u>	
I/I1	Current output 4-20 mA (passive)	
1L=/0L=	Additional power supply	
B1/B2/B1	Binary outputs (passive)	
Data for Intrinsically safe (EEx ib) signal connections.		
<u>Circuits</u>	<u>Maximum values</u>	
I/I1	Ui=30V; Ii=100mA; Pi=1.0W; Ci=20nF; Li=0.	
1L=/0L=		
B1/B2/B1	Ui=30V; Ii=100mA; Pi=1.0W; Ci=0; Li=0.	
Data for Increased safety (EEx e) or Flameproof enclosure (EEx d) signal connections.		
<u>Circuits</u>	<u>Electrical data</u>	
I/I1	U=14-36Vdc; I=4-20mA	
1L=/0L=	U=14-36Vdc; I=22mA	
B1/B2/B1	U < 36V; I < 100mA	
	Um = 60V (for all circuits)	

IFM 4042 K-EEx, type "EEx de"

 Kerkeplaat 12 3313 LC Dordrecht The Netherlands		 
Altometer		
TYPE	IFM 4042 K-EEx	YEAR OF PRODUCTION
		2002
	KEMA 01 ATEX 2200 X	
	II 2GD EEx d [] e [ib] IIC T6...T3	IP65/67
AMBIENT TEMPERATURE: -40...+60°C.		T85...180°C
SEE CERTIFICATE FOR MAXIMUM TEMPERATURES.		
SERIAL NO. <input type="text"/>		
DO NOT OPEN ENCLOSURE WHEN ENERGIZED ! WAITING TIME BEFORE OPENING OF THE FLAMEPROOF ENCLOSURE: T6 ≥ 20 MIN.; T5 ≥ 11 MIN. MAX. SHORT-CIRCUIT CURRENT OF MAINS <input type="text"/> A		
Electrode circuit: only internal connections EEx ib IIC Signal in-/outputs are possible in type of protection Increased safety (EEx e) or Flameproof enclosure (EEx d). Consult manual !		
<u>Circuits</u>	<u>Function</u>	
I/I1	Current output 4-20 mA (passive)	
1L=/0L=	Additional power supply	
B1/B2/B1	Binary outputs (passive)	
Data for Increased safety (EEx e) or Flameproof enclosure (EEx d) signal connections.		
<u>Circuits</u>	<u>Electrical data</u>	
I/I1	U=14-36Vdc; I=4-20mA	
1L=/0L=	U=14-36Vdc; I=22mA	
B1/B2/B1	U < 36V; I < 100mA	
	Um = 250V (for all circuits)	

1.3 Primary head

The primary head is the measuring unit of the IFM 4042 K-EEx compact flowmeter and contains two field coils (see table below for the type of protection) and two electrodes in type of protection intrinsic safety category "ib" according to EN 50020.

Meter size	Type of protection
DN 10 up to DN 150	Housing: Encapsulation "m" according to EN 50028 and increased safety "e" according to EN 50 019 Electrodes: Intrinsic safety "ib" according to EN 50020
DN 200 up to DN 300	Housing: Powder filling "q" according to EN 50017 and increased safety "e" according to 50 019 Electrodes: Intrinsic safety "ib" according to EN 50020
DN 350 and larger	Field coils: Increased safety "e" according to EN 50019 Electrodes: Intrinsic safety "ib" according to EN 50020

NOTE The intrinsically safe electrode circuits of the IFM 4042 K-EEx compact flowmeter are only internal circuits and not accessible for the customer.

1.4 IFC 040-EEEx signal converter

The IFC 040-EEEx signal converter consists of a cylindrical housing of die-casted aluminum, which has two separate compartments, divided from each other by an integrated wall with casted flameproof terminal feed-through. The neck at the bottom of the housing contains a flameproof cable feed-through. The signal converter housing is on both ends closed by a cylindrical threaded cover with O-ring sealing. The housing has an ingress protection degree of at least IP67 conform to EN 60529.

1.4.1 Electronics compartment

The electronics compartment accommodates the pre-certified IFC 040-EEEx electronics unit with approval number PTB 00 ATEX 2213 U. The compartment is designed with type of protection flameproof enclosure "d" according to EN 50018. It is closed by a flameproof display cover with glass window.

1.4.2 Terminal compartment

The terminal compartment has seven terminals for connection of the current output (I, I_L), the additional power supply or "Power Booster" (1L=, 0L=) and binary pulse/status outputs (B1, B_L, B2). Chapter 2 shows the terminal arrangement of the IFC 040-EEEx. There are two versions possible with a different explosion protection according to the European Standards, which is dependent on the safety-technical maximum voltage U_m of the mains power supply system to which the flowmeter is connected.

Version A Terminal compartment "EEEx de [ib]" with U_m = 60 V

The connections of the output circuits can be configured by the customer in one of the following types of explosion protection:

- EEx [ib] (intrinsic safety, category "ib") or
- EEx e (increased safety) or when the precaution in section 1.5 is obeyed
- EEx d (flameproof enclosure)
-

Version B Terminal compartment "EEEx de" with U_m = 250 V

The customer can configure the connections of the output circuits in one of the following types of explosion protection:

- EEx e (increased safety) or when the precaution in section 1.5 is obeyed
- EEx d (flameproof enclosure)

The two versions (A and B) of the terminal compartment as well as their requirements are described in more detail in section 2.3 of these additional instructions.

1.5 Cable or conduit entries

The used cable entries (glands and/or blind plugs) must be ATEX certified. Standard the IFM 4042 K-EEEx flow-meter is delivered with an EEx e cable gland and EEx e blind stop. (see also the EEx code on cable gland and blind stop). The cable gland and blindstop are suitable for connections in EEx e and EEx ib, but not for EEx d.

Safety technical note

Therefore, when connection in EEx d is planned a special EEx d certified conduits, gland(s) or blindstops must be used! ATEX approved "EEx d" cable glands, screw-threaded adapters as well as blind plugs are no integral part of the delivery package and must be purchased by the customer himself or can be ordered through their (local) Krohne representative as special parts ! Note that for a correct choice of the EEx d cable gland the precise cable type and cable dimensions (e.g. outside diameter) must be given.

2 Electrical connection

2.1 Equipotential bonding system

The IFM 4042 K-EEx magnetic-inductive compact flowmeter must be incorporated into the equipotential bonding system through the internal or external PE-clamp. Latter clamp is suitable for wires till 4 mm² cross section.

Disconnection from the equipotential bonding system is only allowed when the flowmeter is not in contact with power supplies or ground voltages outside the hazardous area.

2.2 Terminal arrangement

To connect external devices to the signal output terminals, the wiring requirements for the type of protection of the compartment must also conform to the international or national standard involved (e.g. EN 60079-14). The terminal arrangement is shown by the following figure.

Terminal arrangement in terminal compartment

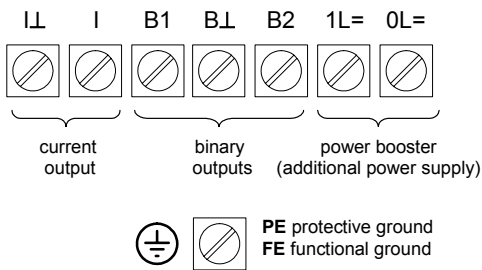

The following outputs are available for connection to external circuits (see figure above):

Current output (terminals I, I⊥)

This circuit constitutes a passive 4-20 mA current loop and includes the HART protocol of the communication device (choice of polarity is free).

Additional power supply or Power Booster (terminals 1L=, 0L=)

These terminals are connected to provide the 2x2 wire mode (choice of polarity is free).

Binary outputs (terminals B1, B⊥, B2)

Terminals B1 and B⊥ can be configured as pulse or status output through software.

Terminals B2 and B⊥ can be configured as pulse or status output to NAMUR.

Galvanical separation of circuits

The internal electrode circuit with type of protection "EEx ib" is galvanically connected to the aluminum signal converter housing (i.e. PE potential).

The current output, the additional power supply and the internal field current circuit are galvanically connected to each other.

2.3 Description of the output circuits

The terminal compartment of the IFM 4042 K-EE is, with respect to the explosion protection, available in two versions. The version can be identified by the information that is listed on the data plate, which is mounted on the signal converter housing.

Version A Terminal compartment "EEx de [ib]" with $U_m = 60\text{ V}$

The customer can decide in which type of explosion protection the output circuits - current output, additional power supply and binary outputs (i.e. pulse and/or status outputs) - can be driven: in type of protection "EEx ib", "EEx e" or "EEx d".

If type of protection EEx e or EEx d is used, the markings for "Intrinsically safe" - that are blue oring around the cable gland and the blue sticker in the connection compartment - should be removed.

The safety-technical maximum voltage U_m (maximum effective AC or DC voltage) of the mains power supply system for the terminal compartment in type of protection EEx de [ib] is restricted to 60 V. With this maximum voltage it is guaranteed that the protective components on which the intrinsic safety of these circuits depends are not overloaded. This condition is met if the mains power supply system satisfies the PELV requirements in accordance with IEC 364 / IEC 536.

Safety technical note

- It is not allowed to mix two different types of protection (e.g. current output in type of protection "EEx ib" and pulse/status outputs in "EEx e" or "EEx d").
- The end-user is allowed to change the type of protection of the terminal compartment by the afterwards a random times, when it is guaranteed that the maximum voltage U_m of the mains power supply system is always limited at 60 V!

Version B Terminal compartment "EEx de" with $U_m = 250\text{ V}$

This version is intended for applications where the mains power supply system provides a maximum safety-technical voltage of $U_m = 250\text{ V}$. The terminals can either be provided with type of protection increased safety "EEx e" according to EN 50019 or flameproof enclosure "EEx d" conform to EN 50018. Type of protection intrinsic safety "EEx ib" is not allowed for this version.

Important notes (applicable for versions A and B)

- The intrinsically safe "EEx ib" internal electrode circuit is supplied by the IFC 040-EEx signal converter electronics unit inside the electronics compartment. This circuit is separated from all other circuits up to a maximum voltage of $U_m = 250\text{ V}$ according to EN 50020. The internal electrode circuit with type of protection intrinsic safety "ib" is galvanically connected with the PE (housing potential).
- The current output (terminals I, I \perp) and the additional power supply (terminals 1L \perp , 0L \perp) must be galvanically separated connected and driven from each other. To avoid voltage or current summation, at least one of the two circuits must be isolated from earth potential. It is not allowed to drive both circuits at the same time with grounded zener barriers. Both current circuits, including all connection cables, must be galvanically separated at all times according to the valid regulations.
- Also in case of non-intrinsically safe connections, it is absolutely necessary to maintain a galvanic separation between the current output circuits and the additional power supply connections.
- A safe connection of the IFC 040-EEx signal converter electronics with the equipotential bonding system is achieved through the zinc-plated mounting frame, which must be securely screwed to the aluminum signal converter housing (PE potential) by means of two long-shafted screws. To access the two long-shafted screws it is necessary to unscrew the display unit and fold it aside. The screws must be tightly secured with a torque of 1.3 Nm (a 2 Pt. Phillips screwdriver is recommended).

2.4 Connection diagram

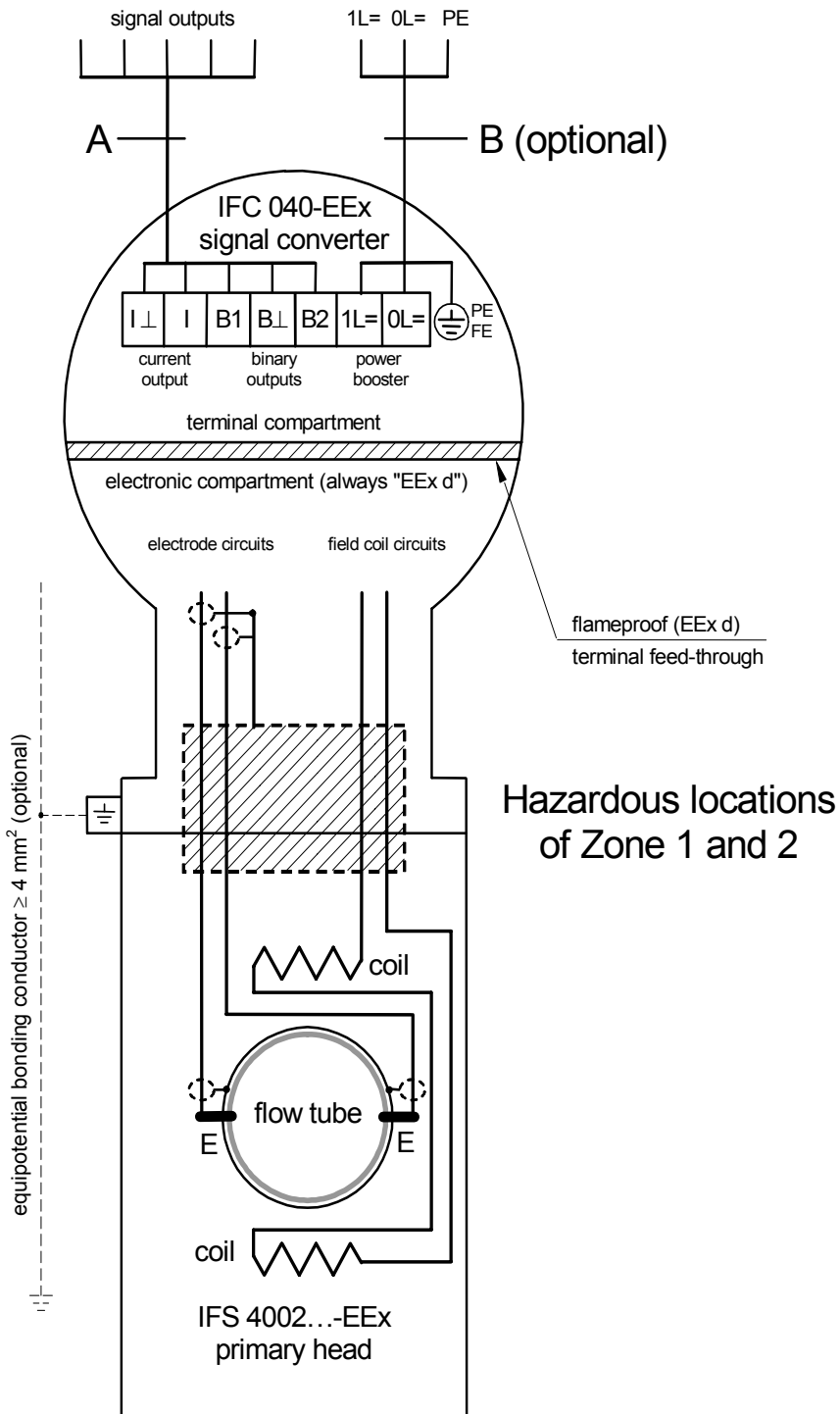

2.5 Safety-technical data

Important The functional-technical data must also be regarded, therefore see the standard installation and operating instructions.

Safety-technical data of output circuits

Terminal designation	Function	Electrical data (per circuit)	
		Type of protection "EEx ib"	Type of protection "EEx e"
Circuit 1 I, I \perp	Current output, passive (2-wire connection) 4 - 20 mA, HART = possible	Maximum values: $U_i = 30\text{ V}$, $I_i = 100\text{ mA}$, $P_i = 1.0\text{ W}$ $C_i = 20\text{ nF}$, $L_i = 0$ $U_m = 60\text{ V}$	$U_n = 14 - 36\text{ Vdc}$ $I_n = 4 - 20\text{ mA}$ $U_m = 250\text{ V}$
Circuit 2 1L=, 0L=	Additional power supply or Power Booster, (4-wire connection) additional to circuit 1 (option)		$U_n = 14 - 36\text{ Vdc}$ $I_n = 22\text{ mA}$ $U_m = 250\text{ V}$
Circuit 3 B1, B \perp B2, B \perp	Passive pulse/status output 1 Passive pulse/status output 2	Maximum values: $U_i = 30\text{ V}$, $I_i = 100\text{ mA}$, $P_i = 1.0\text{ W}$ $C_i = 0$, $L_i = 0$ $U_m = 60\text{ V}$	Maximum values: $U = 36\text{ V}$ $I = 100\text{ mA}$ $U_m = 250\text{ V}$

2.6 Connection examples

In the following sections examples for connection of the IFM 4042 K-EEx compact flowmeter are described for operation in the 2-wire mode as well as in the 2x2-wire mode.

2.6.1 Example of IFM 4042 K in 2-wire mode

The diagram shows an IFM 4042 K-EEx with the terminal compartment in version A (EEx de [ib] with $U_m = 60\text{ V}$). The flowmeter is connected through a transmitter power supply ("EEx i" approved) in 2-wire mode. If data communication with the flowmeter through the HART protocol is required, the transmitter power supply unit must be HART compatible. Terminals I, I \perp are not polarity sensitive.

The entity parameters of the "EEx i" approved transmitter power supply, including the cable capacitances and inductances, must fit the entity parameters of the IFM 4042 K-EEx-EEx compact flowmeter, namely $U_i = 30\text{ V}$, $I_i = 100\text{ mA}$, $C_i = 200\text{ nF}$, $L_i = 0$. Suitable HART compatible transmitter power supplies that can be used in combination of the Altoflux 2W IFM 4042 K-EEx are:

- Phoenix PI/Ex-ME-RPSS-I/I
- CEAG 6/420

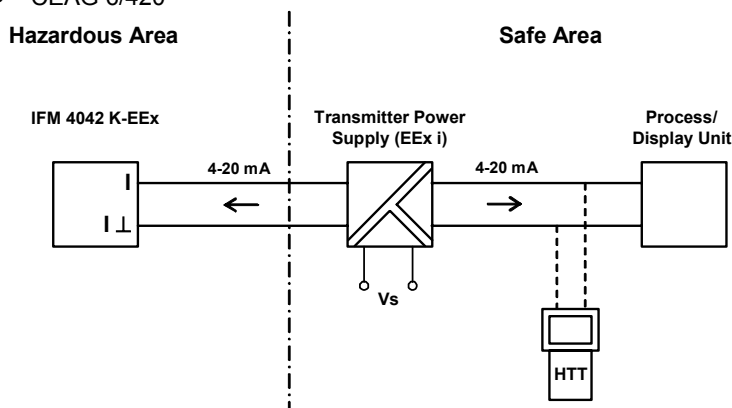

2.6.2 Example of IFM 4042 K in 2x2-wire mode (4-wire)

The diagram shows an example of the connection of the IFM 4042 K-EEEx in 2x2-wire mode. As in the previous example (see Sect. 2.6.1), the terminal compartment is again version A.

The additional power supply (terminals 1L=, 0L=) of the IFM 4042 K-EEEx is supplied by an external power supply unit through an "EEEx i" zener barrier with a linear output load. The connection of the current output (terminals I, I ⊥) and the additional power supply (terminals 1L=, 0L=) is insensitive for polarity reversal.

Important notes!

Only one of the two connected circuits of the IFM 4042 K-EEEx, namely the "current output" or the "additional power supply" may be earthed to maintain the required galvanic separation between the two circuits!

It is strictly interdicted to use the IMoCOM adapter with the IFC040-EEEx unit!

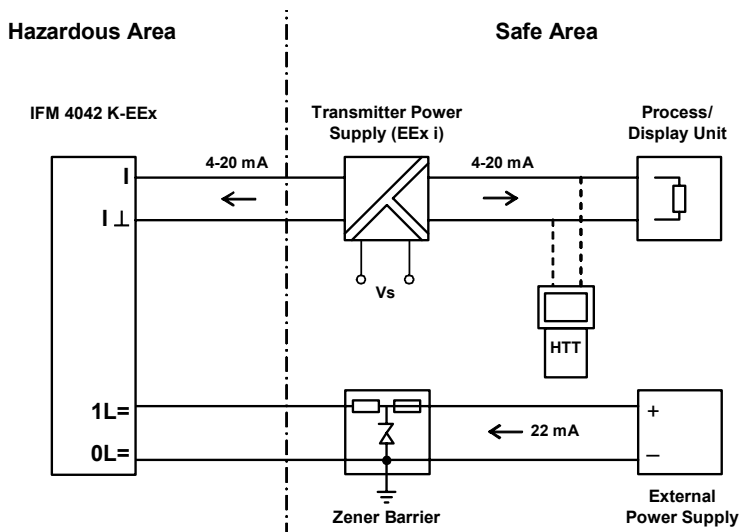

The voltage of the external power supply unit must be carefully chosen to keep it within the allowed limits. The upper limit is determined by the maximum working voltage of the zener barrier, which in general lies a few volts below the maximum open voltage value U_0 of the used zener barrier. The lower limit is determined by the sum of the minimum working voltage of the additional power supply of the IFM 4042 K-EEEx flowmeter of 14 V and the voltage drop over the zener barrier caused by the end-to-end resistance of the barrier and (if not neglectable) the serie cable resistance. This voltage drop can be significant. The above described determination of the external power supply voltage is explained by the following example.

Example with typical parameters:

Zener barrier data: $U_0 = 28 \text{ V}$
 $I_0 = 93 \text{ mA}$
 Maximum working voltage = 25.5 V
 End-to-end resistance = 340 Ω

The voltage drop across the end-to-end resistance of the zener barrier is: $22 \text{ mA} \times 340 \Omega = 7,5 \text{ V}$

This means that the external power supply must supply an output voltage to the zener barrier that lies in the range somewhere between 21,5 - 25,5 V. The voltage over the terminals of the additional power supply of the IFM 4042 K-EEEx is in that case between the required 14,0 - 18,0 V.

3 Operation of the signal converter

The IFM 4042 K-EEEx contains the IFC 040-EEEx signal converter electronics unit, which is equipped with a display unit that contains magnetic Hall sensors. These Hall sensors enable the settings of the IFC 040-EEEx electronics unit to be set respectively reset with the help of the with the apparatus delivered bar magnet without opening the flameproof signal converter housing in the hazardous area.

Consult the standard Installation and Operating Instructions for the program functions of the software of the IFC 040-EEEx electronics unit.

4 Maintenance

The IFM 4042 K-EEEx magnetic-inductive compact flowmeters are maintenance free with regard to the flowmetering properties. Within the scope of the periodical inspections, which are required for electrical apparatus that are installed and used in hazardous classified locations, it is recommended to check the flameproof enclosures on signs of damage or corrosion. This concerns the converter housing and for sizes DN25 till DN150 also the primary head housing.

5 Ordering information

In case of questions about spare or replacing parts contact your local Krohne representative. The part number of the IFC 040-EEEx electronics unit is 2.12896.01.00.

6 Technical data

Safety technical note

The following maximum safety technical process liquid temperatures are absolute safety-technical limits. Due to function-technical reasons (e.g. measuring accuracy) lower process liquid temperatures can be in effect, see also the standard installation and operating instructions of the Altoflux 2W electromagnetic compact flowmeter type IFM 4042 K-EEEx!

Ambient temperature T_a -40°C...+60°C

Maximum safety technical process liquid temperature

see EC-Certificate of the IFM 4042 K-EEEx with No. KEMA 01
ATEX 2200 X in Sect. 9 and the Tables in Sect. 1.1

7 Replacement of electronic unit

Important!

The following instructions must be followed carefully, when the IFC 040-EEEx signal converter housing has to be opened respectively closed again !

Before opening

- Make absolutely sure that there is no explosion hazard!
- If necessary provide a "Gas-free certificate"!
- Make sure that all connecting cables are safely isolated from the power supply!

When the instructions above are strictly followed, the display cover (with the glass window) can be removed.

7.1 Removal of the electronics unit

- Raise the latch of the interlocking device by loosening the hexagon socket head cap screw size 3, until the cover can rotate freely.
- Unscrew the cover with the special plastic wrench (black) that is supplied with the apparatus.
- Unscrew the two screws of the display unit and turn it carefully aside.
- Carefully disconnect the 12 pin connector (for field coil and electrode circuits connection) from the electronic unit.
- Unscrew the two mounting screws of the electronics unit, which fixes the metal frame to the back of the signal converter housing. A crosshead screwdriver type 2 Pt. Phillips is most suitable.
- Carefully remove the electronics unit of the converter housing (see the Remark below).

Remark!

Carefully keep the connecting cables of the field coil and electrode circuits to the side of the housing, while removing respectively inserting the electronics unit into the signal converter housing. This is to prevent damaging of the connecting cables!

7.2 Insertion of the electronics unit

Reassemble in reverse order with the replacement of the IFC 040-EEEx electronics unit:

- Insert the electronics unit in the converter housing
- Tighten the two mounting screws of the electronics unit.
- The metal frame of the IFC 040-EEEx electronics unit must be securely screwed to the housing (back-end of electronics compartment) by the two non-removable fastening screws. Screw them with a tightening torque of 1.3 Nm.

Remark!

These two screw-connections also establish the safety-technical connection of the electronics unit to the signal converter housing and equipotential bonding system.

- Connect the 12-pin connector
- Mount the display-unit
- Before the cover is screwed back into the housing, the screw-thread must be clean and well-greased with an acid and resin-free grease, e.g. silicone grease.
- Screw the display cover as tight as possible into the housing by hand, so that the gasket of the cover must be clamped to provide the required Ingress Protection (IP) degree.
- Tighten the hexagon socket head cap screw of the interlocking device.

Refer to the standard Installation and Operating Instructions for detailed information about resetting and reprogramming the new electronics unit after replacement.

8 EC Declaration of conformity



EC - Declaration of Conformity

We

Krohne Altometer
Kerkeplaat 12
3313 LC Dordrecht
The Netherlands

declare under our sole responsibility that the products

compact magnetic inductive flowmeter types

IFM 4080 K - EEx and
IFM 4080 K / i- EEx
IFM 4042 K- EEx

fulfill the requirements of following EC directives:

- ATEX Directive 94/9/EC
- EMC Directive 89/336/EC

The IFM 4080 K-EEx, IFM 4080 K / i-EEx and IFM 4042 K-EEx flowmeters are designed and manufactured conform following harmonized standards:

- EN 50 014 : 1997
- EN 50 018 : 2000
- EN 50 019 : 2000
- EN 50 020 : 1994
- EN 50 281-1-1 : 1998

- EN 50 081-1
- EN 50 082-2
- EN 61 010-1

The IFM 4080 K-EEx, IFM 4080 K / i-EEx and IFM 4042 K-EEx flowmeters are examined and type-approved under EC-type examination certificate KEMA 01 ATEX 2200 X. Our quality system is assessed by KEMA registered Quality b.v.

Dordrecht, 26-03-2002

L. IJmker
(General manager)



9 EC-Type examination certificate

KEMA 



(1) **EC-TYPE EXAMINATION CERTIFICATE**

- (2) Equipment or protective system intended for use in potentially explosive atmospheres – Directive 94/9/EC
- (3) EC-Type Examination Certificate Number: **KEMA 01ATEX2200 X**
- (4) Equipment or protective system: **Compact Magnetic Inductive Flowmeter, types IFM 4080 K/...-EEx, IFM 4042 K-EEx, MGM 4090 K/...-EEx and MGM 4042 K-EEx**
- (5) Manufacturer: **Krohne Altometer**
- (6) Address: **Kerkeplaat 12, 3313 LC Dordrecht, The Netherlands**
- (7) This equipment or protective system and any acceptable variation thereto is specified in the schedule to this certificate and the documents therein referred to.
- (8) KEMA Quality B.V., notified body number 0344 in accordance with Article 9 of the Council Directive 94/9/EC of 23 March 1994, certifies that this equipment or protective system has been found to comply with the Essential Health and Safety Requirements relating to the design and construction of equipment and protective systems intended for use in potentially explosive atmospheres given in Annex II to the Directive.

The examination and test results are recorded in confidential report no. 2011064.

- (9) Compliance with the Essential Health and Safety Requirements has been assured by compliance with:

EN 50014 : 1997
EN 50020 : 1994

EN 50018 : 2000
EN 50281-1-1 : 1998

EN 50019 : 2000

- (10) If the sign "X" is placed after the certificate number, it indicates that the equipment or protective system is subject to special conditions for safe use specified in the schedule to this certificate.
- (11) This EC-Type Examination Certificate relates only to the design, examination and tests of the specified equipment or protective system in accordance with the Directive 94/9/EC. Further requirements of the Directive apply to the manufacturing process and supply of this equipment or protective system. These are not covered by this certificate.
- (12) The marking of the equipment or protective system shall include the following:



**II 2 GD EEx d [ib] IIC T6...T3 or EEx de [ib] IIC T6...T3 or
EEx d [ia] [ib] IIC T6...T3 or EEx de [ia] [ib] IIC T6...T3
T 85...180 °C**

Arnhem, 28 March 2002

KEMA Quality B.V.



T. Pijpker
Certification Manager

* This Certificate may only be reproduced in its entirety and without any change

KEMA Quality B.V.
Utrechtseweg 310, 6812 AR Arnhem, The Netherlands
P.O. Box 5185, 6802 ED Arnhem, The Netherlands
Telephone +31 26 3 56 20 08, Telefax +31 26 3 52 58 00

ACCREDITED BY THE
DUTCH COUNCIL FOR
ACCREDITATION



Page 1/6

(13)

SCHEDULE

(14)

to EC-Type Examination Certificate KEMA 01ATEX2200 X

(15) **Description**

The Compact Magnetic Inductive Flowmeter, types IFM 4080 K/...-EEx, IFM 4042 K-EEx, MGM 4090 K/...-EEx and MGM 4042 K-EEx is used for measuring, counting and displaying the linear flow of an electrical conductive liquid.

The flowmeter consists of a signal converter housing in type of explosion protection flameproof enclosure "d" with a terminal compartment in type of explosion protection flameproof enclosure "d" or increased safety "e". The integral primary heads are in type of explosion protection flameproof enclosure "d" (sizes DN25 - DN150) or increased safety "e" (DN200 - DN3000) and are provided with measuring electrodes in type of explosion protection intrinsic safety EEx ib IIC.

Ambient temperature range -20 °C ... +60 °C (for flowmeter with electronics unit type IFC 090i).

Ambient temperature range -40 °C ... +60 °C (for flowmeter with electronics unit types IFC 040 and IFC 090).

The maximum surface temperature T 85...180 °C is based on a maximum ambient temperature of 60 °C.

Electrical data

IFM4080 K/...-EEx / MGM 4090 K/...-EEx with IFC 090-EEx electronics

Power supply 100/200 Vac, 115/230 Vac -15/+10 %, 10 VA
24 Vdc -25/+30 %, 24 Vac -15/+10 %, 8 W
U_m = 253 V

Signal I/O's ≤ 36 Vdc

IFM4080 K/...-EEx / MGM 4090 K/...-EEx with IFC 090i-EEx electronics

Power supply 100...230 Vac -15/+10 %, 15 VA
24 Vdc -25/+30 %, 24 Vac -15/+10 %, 10 W
U_m = 253 V

Signal circuit

Modules P-SA and FA-ST in type of explosion protection intrinsic safety EEx ia IIC, only for connection to a certified intrinsically safe circuit in type of explosion protection intrinsic safety
EEx ia IIC or EEx ia IIB or
EEx ib IIC or EEx ib IIB,
with the following maximum values:

U _i	=	30	V
I _i	=	250	mA
P _i	=	1,0	W

The effective internal capacitance C_i = 5 nF,
the effective internal inductance L_i is negligibly small.

(13)

SCHEDULE

(14)

to EC-Type Examination Certificate KEMA 01ATEX2200 X

Electrical data (continued)

Signal circuit

Modules F-PA and F-FF

in type of explosion protection intrinsic safety EEx ia IIC, only for connection to a certified intrinsically safe circuit (for instance a Supply of the FISCO Model in accordance with document CLC/SC31-3(SEC)155 of Dec. 2000) in type of explosion protection intrinsic safety

EEx ia IIC or EEx ia IIB or

EEx ib IIC or EEx ib IIB,

with the following maximum values:

$$\begin{aligned} U_i &= 30 & \text{V} \\ I_i &= 300 & \text{mA} \\ P_i &= 4,2 & \text{W} \end{aligned}$$

The effective internal capacitance $C_i = 5 \text{ nF}$,
the effective internal inductance L_i is negligibly small.

Signal/supply circuit

Module DC-1
(24 Vac/dc version only)

in type of explosion protection intrinsic safety EEx ia IIC, with the following maximum values:

$$\begin{aligned} U_o &= 23,5 & \text{V} \\ I_o &= 98 & \text{mA} \\ P_o &= 0,6 & \text{W} \end{aligned}$$

Maximum allowed external capacitance $C_o = 127 \text{ nF}$,
maximum allowed external inductance $L_o = 4 \text{ mH}$.

Only for connection to certified intrinsically safe circuits in type of explosion protection EEx ia IIC or EEx ia IIB or EEx ib IIC or EEx ib IIB without supply (passive).

The applicable type of explosion protection of the aforementioned intrinsically safe circuits EEx ia IIC is determined by the type of protection of the intrinsically safe circuit which is connected to it, respectively EEx ia IIB or EEx ib IIC or EEx ib IIB.

The aforementioned intrinsically safe circuits shall, from the safety point of view, be considered to be connected to ground.

IFM 4042 K-EEx / MGM 4042 K-EEx with IFC 040-EEx electronics

The signal/supply circuits may all be connected either intrinsically safe or non-intrinsically safe. A combination of intrinsic and non-intrinsic safe connections however is not allowed.

a) Connection to a non-intrinsically safe circuit

Signal/supply circuit 1 14 - 36 Vdc, 4 - 20 mA

Signal/supply circuit 2 14 - 36 Vdc, 22 mA

Signal/supply circuit 3 max. 36 Vdc, 100 mA

(13)

SCHEDULE

(14)

to EC-Type Examination Certificate KEMA 01ATEX2200 X

Electrical data (continued)

b) Connection to an intrinsically safe circuit

Signal/supply circuits 1 and 2... in type of explosion protection intrinsic safety EEx ib IIC with the following maximum values (each circuit):

$$\begin{array}{rcl} U_i & = & 30 \text{ V} \\ I_i & = & 100 \text{ mA} \\ P_i & = & 1,0 \text{ W} \end{array}$$

The effective internal capacitance $C_i = 20 \text{ nF}$,
the effective internal inductance L_i is negligibly small.

Signal/supply circuit 3 in type of explosion protection intrinsic safety EEx ib IIC with the following maximum values:

$$\begin{array}{rcl} U_i & = & 30 \text{ V} \\ I_i & = & 100 \text{ mA} \\ P_i & = & 1,0 \text{ W} \end{array}$$

The effective internal capacitance C_i is negligibly small,
the effective internal inductance L_i is negligibly small.

The applicable type of explosion protection of the aforementioned intrinsically safe circuits EEx ib IIC is determined by the type of protection of the intrinsically safe circuit which is connected to it, respectively EEx ib IIB.

The aforementioned intrinsically safe circuits are safely galvanically separated from the non-intrinsically safe circuits up to a peak value $U_m = 60 \text{ V}$.

Installation instructions

For use in potentially explosive atmospheres of flammable gases, fluids or vapours:
The cable entry device shall be in type of protection flameproof enclosure "d" for the terminal compartment in type of protection flameproof enclosure "d" or increased safety "e" for the terminal compartment in type of protection increased safety "e", suitable for the conditions of use and correctly installed.

For use in the presence of combustible dust:
The cable entry device shall be in type of equipment Category II 2 D, suitable for the conditions of use and correctly installed.

Unused openings shall be closed with suitable certified closing elements.

With the use of conduit, a suitable certified sealing device such as a stopping box with setting compound shall be provided immediately at the entrance to the flameproof enclosure.

Routine tests

- Each welded primary head of size DN25 - DN150 must be submitted to the routine overpressure test according to EN 50018, Clause 16 at a test pressure of 14 bar during one minute.

(13)

SCHEDULE

(14)

to EC-Type Examination Certificate KEMA 01ATEX2200 X

Routine tests (continued)

- Routine tests according to EN 50018, Clause 16 are not required for the electronics enclosure since the type test has been made at a static pressure of four times the reference pressure.

Each primary head of size DN200 - DN3000 shall withstand a test voltage according to EN 50019, Clause 6.1, of 500 V during one minute without breakdown between the field coils circuit and the enclosure and a test voltage of 1500 Vrms during one minute without breakdown between the field coils circuit and the intrinsically safe sensor circuit.

(16) **Report**

KEMA No. 2011064.

(17) **Special conditions for safe use**

The relation between temperature class, maximum surface temperature, maximum process temperature and ambient temperature is shown in the following tables:

a) Meter size DN25 - DN150

Temperature class	Max. surface temperature	Max. process temperature		
		Ta ≤ 40 °C	Ta ≤ 50 °C	Ta ≤ 60 °C
T6	T 85 °C	70 °C	70 °C	70 °C
T5	T 100 °C	85 °C	85 °C	85 °C
T4	T 135 °C	120 °C	120 °C	115 °C
T3	T 180 °C	180 °C	180 °C	115 °C

For Ta > 50 °C and a process temperature ≤ 115 °C, heat resistant cables with a continuous operating temperature of at least 120 °C must be used.

b) Meter size DN200 - DN3000

Temperature class	Max. surface temperature	Max. process temperature		
		Ta ≤ 40 °C	Ta ≤ 50 °C	Ta ≤ 60 °C
T6	T 85 °C	75 °C	70 °C	70 °C
T5	T 100 °C	95 °C	90 °C	75 °C
T4	T 135 °C	130 °C	115 °C	75 °C
T3	T 180 °C	150 °C	115 °C	75 °C

(18) **Essential Health and Safety Requirements**

Covered by the standards listed at (9).

(13)

SCHEDULE

(14)

to EC-Type Examination Certificate KEMA 01ATEX2200 X

(19) **Test documentation**

1. Component Certificate KEMA No. Ex-99.E.8128 U
KEMA No. Ex-01.E.2036 U
Certificate of Conformity KEMA No. Ex-97.D.2886 X
PTB No. Ex-90.C.2003 X
PTB No. Ex-95.D.2209
EC-Type Examination Certificate KEMA 01ATEX2263 X
PTB 98 ATEX 2012 U
PTB 00 ATEX 2213 U

dated

2. Description (22 pages) 04.03.2002
3. Drawings index sheet 04.03.2002

AMENDMENT 1

to EC-Type Examination Certificate KEMA 01ATEX2200 X

Manufacturer: **Krohne Altometer**

Address: **Kerkeplaat 12, 3313 LC Dordrecht, The Netherlands**

Description

In future the Compact Magnetic Inductive Flowmeter, types IFM 4080 K/...EEx, IFM 4042 K-EEx, MGM 4090 K/...EEx and MGM 4042 K-EEx may also be provided with integral primary heads with sizes DN10 - DN20 and DN200 - DN300. The primary heads are in type of explosion protection encapsulation "m" (DN10 - DN20) or powder filling "q" (DN200 - DN300), and are provided with measuring electrodes in type of explosion protection intrinsic safety EEx ib IIC.

The flowmeters shall be marked with the following code:

DN10 - DN20:  II 2 GD EEx dme [ib] IIC T6...T3 or EEx dme [ia] [ib] IIC T6...T3, T 85...150 °C

DN200 - DN300:  II 2 GD EEx dqe [ib] IIC T6...T3 or EEx dqe [ia] [ib] IIC T6...T3, T 85...150 °C

Routine tests

The following routine tests of EN 50028 must be carried out on the primary heads with sizes DN10 - DN20:

- Clause 7.1: Visual check.
- Clause 7.2: Each primary head shall withstand a test voltage of 1500 V during one minute without breakdown between the field coils circuit and the enclosure and between the field coils circuit and the intrinsically safe sensor circuit.
- Clause 7.3: Checking the electrical data.

The following routine test of EN 50017 must be carried out on the primary heads with sizes DN200 - DN300:

- Clause 13.2: Electric strength test of the filling material.

Special conditions for safe use

The relation between temperature class, maximum surface temperature, maximum process temperature and ambient temperature is shown in the following table:

Temperature class	Max. surface temperature	Max. process temperature		
		Ta ≤ 40 °C	Ta ≤ 50 °C	Ta ≤ 60 °C
T6	T 85 °C	75 °C	70 °C	70 °C
T5	T 100 °C	95 °C	90 °C	75 °C
T4	T 135 °C	130 °C	115 °C	75 °C
T3	T 150 °C	150 °C	115 °C	75 °C

The maximum surface temperature T 85...150 °C is based on a maximum ambient temperature of 60 °C.

All other data remain unchanged.

AMENDMENT 1

to EC-Type Examination Certificate KEMA 01ATEX2200 X

Test documentation

	<u>dated</u>
1. Description (11 pages), rev. 2	10.09.2002
2. Drawing List	10.09.2002

Arnhem, 7 October 2002
KEMA Quality B.V.



T. Pijpker
Certification Manager

[2019197]

Page 2/2

AMENDMENT 3**to EC-Type Examination Certificate KEMA 01ATEX2200 X**

Manufacturer: **Krohne Altometer**

Address: **Kerkeplaat 12, 3313 LC Dordrecht, The Netherlands**

Description

The range of Compact Magnetic Inductive Flowmeters, types IFM 4080 K/...-EEx, IFM 4042 K-EEx, MGM 4090 K/...-EEx and MGM 4042 K-EEx is extended with type Optiflux 4040 C-EEx.

Type Optiflux 4040 C-EEx is equal to type IFM 4042 K-EEx with some minor changes according to the documentation stated below. The changes concern the mechanical and electrical assembly.

All other data remain unchanged.

Test documentation

	<u>signed</u>
1. Description (5 pages)	14.04.2004
2. Drawing list	08.06.2004
3. Appendix list	14.04.2004

Arnhem, 29 June 2004
KEMA Quality B.V.



C. G. van Es
Certification Manager