

Addition to the installation and operating instructions

ALTOFLUX IFM 4080 K-EEEx / i-EEEx PROFIFLUX IFM 5080 K-EEEx / i-EEEx VARIFLUX IFM 6080 K-EEEx / i-EEEx

Compact electromagnetic flowmeters

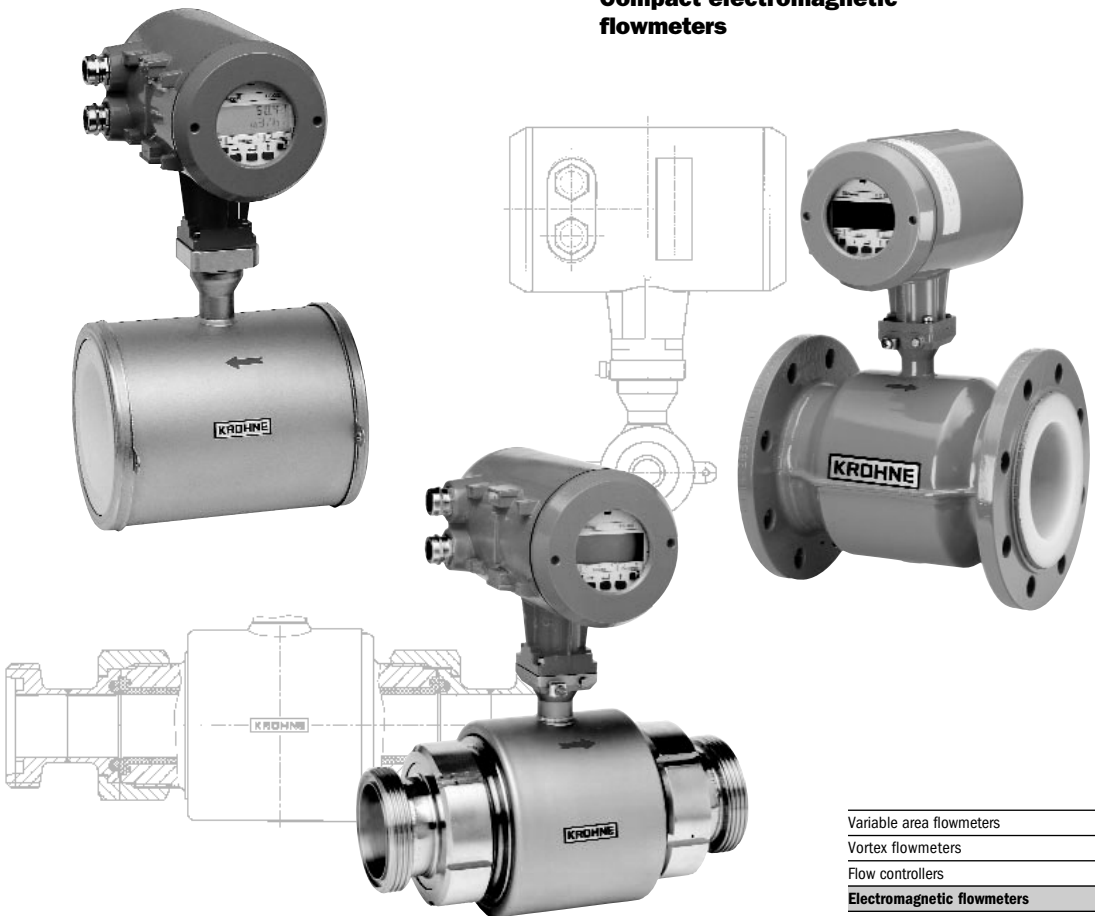

Variable area flowmeters

Vortex flowmeters

Flow controllers

Electromagnetic flowmeters

Ultrasonic flowmeters

Mass flowmeters

Level measuring instruments

Communications technology

Engineering systems & solutions

Switches, counters, displays and recorders

Heat metering

Pressure and temperature

WARNING ! No changes regarding safety may be made to the devices. Unauthorized changes might affect the explosion safety of the devices.

Be sure to follow these instructions !

IMPORTANT !	<ul style="list-style-type: none">• The prescriptions and regulations as well as the electrical data described in the EC-type examination certificate must be obeyed.• Beside the instructions for electrical installations in non-hazardous locations according to the applicable national standard (e.g. IEC 364), especially the regulations in EN 60079-14 "Electrical installations in hazardous locations" or equivalent national standard must be followed.• Installation, establishment, utilization and maintenance are only allowed to be executed by personnel with an education in explosion safety!
--------------------	--

These additional instructions are an extension to the Installation and Operating Instructions and only apply to the EEx version of the IFM x080 K - EEx or IFM x080 K / i -EEx electromagnetic compact flowmeter. All technical information described in the "Installation and Operating Instructions" are applicable, when not specifically excluded, completed or replaced by the instructions in these additional instructions.

Content

1	System components	3
1.1	General information ALTOFLUX IFM 4080 / ... EEx	4
1.2	General information PROFIOFLUX IFM 5080 / ... EEx	6
1.3	General information VARIFLUX IFM 6080 / ... EEx	8
1.4	IFC 090 / ... -EEx signal converter	10
1.4.1	Electronics compartment	10
1.4.2	Terminal compartment	10
1.5	Electronics unit	11
2	Electrical connection	11
2.1	Equipotential bonding system	12
2.2	Connecting cables	12
2.3	Connection diagram	13
2.4	Regular IFC 090 - EEx electronics unit	14
2.5	Modis version IFC 090 I	15
2.6	Connection diagrams MODIS	16
3	Operation of the signal converter	22
4	Maintenance	22
5	Service	23
5.1	General information for replacements	24
5.2	Replacement of electronics unit	25
5.3	Replacement of power fuse(s)	27
5.4	Changing power supply voltage	30
6	Ordering information	31
6.1	Regular IFC 090 - EEx electronics unit	31
6.2	MODIS version IFC 090 - EEx electronics unit	31
7	Declaration of conformity	31
7.1	Declaration of conformity of ALTOFLUX IFM 4080 K ... EEx	32
7.2	Declaration of conformity of PROFIOFLUX IFM 5080 ... EEx	33
7.3	Declaration of conformity of VARIFLUX IFM 6080 ... EEx	34
8	EC-type examination Certificates	34
8.1	ALTOFLUX IFM 4080 K ... EEx Certificate	35
8.2	PROFIOFLUX IFM 5080 ... EEx Certificate	38
8.3	VARIFLUX IFM 6080 ... EEx Certificate	40

1 System components

1.1 General information ALTOFLUX IFM 4080 / ... EEx

This meter complies with the European Directive 94/9/EC (ATEX 100a) and approved for hazardous classified locations of Zone 1 and 2 under EC-type Examination Certificate number:

KEMA 01 ATEX 2200 X

The compact flowmeter is available in two types, namely:

IFM 4080 K-EEx regular explosion protected version;

IFM 4080 K/i-EEx, MODIS version. This type has intrinsically safe signal output circuits, which are provided by two on the IFC 090i-EEx electronics unit installed MODIS modules.

The regular IFM 4080 K-EEx compact flowmeter is designed for ambient temperatures (T_a) in the range of -20°C (special -40°C) up to $+60^{\circ}\text{C}$, the MODIS version type IFM 4080 K/i-EEx is rated for ambient temperatures from -20°C up to $+60^{\circ}\text{C}$.

The allowed process liquid temperature is limited by the maximum occurring surface temperature of system components in the combustible atmosphere that (possibly) surrounds the apparatus, determined by the temperature class of the atmosphere (first column of the tables). See table 1 and 2 below for details.

For dusts the second column of the two below listed tables is applicable.

Temperature classification DN200 and larger

Temperature class (for gases)	Max. surface temperature (for dusts)	Maximum process liquid temperature		
		$T_a \leq 40^{\circ}\text{C}$	$T_a \leq 50^{\circ}\text{C}$	$T_a \leq 60^{\circ}\text{C}$
T6	T85°C	75°C	70°C	70°C
T5	T100°C	95°C	90°C	75°C
T4	T135°C	130°C	115°C	75°C
T3	T180°C	150°C	115°C	75°C

Temperature classification DN 25...150 with PFA liner

Temperature class (for gases)	Max. surface temperature (for dusts)	Maximum process liquid temperature		
		$T_a \leq 40^{\circ}\text{C}$	$T_a \leq 50^{\circ}\text{C}$	$T_a \leq 60^{\circ}\text{C}$
T6	T85°C	70°C	70°C	70°C
T5	T100°C	85°C	85°C	85°C
T4	T135°C	120°C	120°C	115°C
T3	T180°C	180°C	180°C	115°C
Use heat-resistant cables above		-	-	50°C

The IFM 4080 K / ... EEx flowmeter consists of the IFC 090/...-EEx signal converter unit, which is screwed on top of the primary head (i.e. measuring unit).

The compact flowmeter is marked with one of the codes below, depending on the meter size:

DN25-150 II 2GD EEx d [ib] IIC T6...T3 (EEx d terminal compartment) or

II 2GD EEx de [ib] IIC T6...T3 (EEx e terminal compartment).

DN200 and up II 2GD EEx de [ib] IIC T6...T3 (both EEx d and EEx e terminal compartment).

In case of the MODIS version IFM 4080 K / i-EEx, the electronics unit of type IFC 090i-EEx is provided with protective modules, which provide intrinsically safe output signals of category "ia".

The flowmeter is then marked with one of the following codes:

DN25-150	II 2GD EEx d [ia] [ib] IIC T6...T3 (EEx d terminal compartment) or II 2GD EEx de [ia] [ib] IIC T6...T3 (EEx e terminal compartment)
DN200 and up	II 2GD EEx de [ia] [ib] IIC T6...T3 (both EEx d and EEx e terminal compartment)

For details see the EC-type Examination Certificate in Sect. 8.1 of these instructions .

Primary head

The primary head contains two field coils (see table for type of protection) and two electrodes in type of protection intrinsic safety category "ib" according to EN 50020.

Types of protection of primary head

Meter size	Type of protection	
DN25 up to DN150	Housing:	Flameproof enclosure "d" according to EN 50018
	Electrodes:	Intrinsic safety "ib" according to EN 50020
DN200 and larger	Field coils:	Increased safety "e" according to EN 50019
	Electrodes:	Intrinsic safety "ib" according to EN 50020

NOTE: The intrinsically safe electrode circuits of the IFM 4080K/...-EEx compact flowmeter are only internal circuits and not accessible for the customer

Data plates of ALTOFLUX IFM 4080 K

IFM 4080 K ... EEx

KROHNE		Kerkeplaat 12 3313 LC Dordrecht The Netherlands		0344
Altometer				
TYPE	IFM 4080 K-EEx			YEAR OF PRODUCTION
KEMA 01 ATEX 2200 X		2002		
II 2GD EEx d		[b] IIC T6...T3		
AMBIENT TEMPERATURE: -40...+60%DC.		IP65/67		
SEE CERTIFICATE FOR MAXIMUM TEMPERATURES.		T85...180%DC		
SERIAL NO.				
POWER	48-63Hz	Vac + % - %	Vdc	+30% -25%
	10VA	Um=253V	8W	
INTRINSICALLY SAFE CIRCUITS, ELECTRODE CIRCUIT, ONLY INTERNAL CONNECTIONS.				
DO NOT OPEN ENCLOSURE WHEN ENERGIZED!				
WAITING TIME BEFORE OPENING OF THE FLAMEPROOF ENCLOSURE: T6 %242 20 MIN.; T5 %242 11 MIN.				
MAX. SHORT-CIRCUIT CURRENT OF MAINS				A
SPACE FOR ADDITIONAL DATA				

IFM 4080 K / i ... EEx

KROHNE		Kerkeplaat 12 3313 LC Dordrecht The Netherlands		0344
Altometer				
TYPE	IFM 4080 K/i-EEx			YEAR OF PRODUCTION
KEMA 01 ATEX 2200 X		2002		
II 2GD EEx d		[b] [a] IIC T6...T3		
AMBIENT TEMPERATURE: -20...+60%DC.		IP65/67		
SEE CERTIFICATE FOR MAXIMUM TEMPERATURES.		T85...180%DC		
SERIAL NO.				
POWER	<input type="checkbox"/> Term. 24Vac,+10%/-15%,48-63Hz,10W 1L-TOL - 24Vdc,+30%/-25%,10W,Um=253V <input type="checkbox"/> Term. 100...230Vac,+10%/-15% L,N 48-63Hz,8W,Um=253V			
DO NOT OPEN ENCLOSURE WHEN ENERGIZED!				
WAITING TIME BEFORE OPENING OF THE FLAMEPROOF ENCLOSURE: T6 %242 20 MIN.; T5 %242 11 MIN.				
MAX. SHORT-CIRCUIT CURRENT OF MAINS				A
INTRINSICALLY SAFE CIRCUITS				
Electrode circuit: only internal connections			EEx b IIC	
%uTerm.				
<input type="checkbox"/> II	Passive output			
<input type="checkbox"/> B1B1	U _i =30V; I _i =250mA; P _i =1.0W	EEx ia IIC		
<input type="checkbox"/> B2B2	C _i =5nF; L _i =0;			
<input type="checkbox"/> D/D	Passive output			
	U _i =30V; I _i =300mA; P _i =4.2W	EEx ia IIC		
	C _i =5nF; L _i =0;			
<input type="checkbox"/> I+/I	Active output			
<input type="checkbox"/> B1+B1	U _o =23.5V; I _o =98mA; P _o =0.6W	EEx ia IIC		
	C _o =132nF; L _o =4mH;			

1.2 PROFIFLUX IFM 5080 K ... EEx

The Profiflux IFM 5080 K/...-EEx magnetic-inductive compact flowmeter is in accordance with the European Directive 94/9/EC (ATEX 100a) and approved for hazardous classified locations of Zone 1 and 2 under EC-type Examination Certificate number:

KEMA 01 ATEX 2262 X

The compact flowmeter is available in two types, namely:

- IFM 5080 K-EEx regular explosion protected version;
- IFM 5080 K/i-EEx, MODIS version. This type has intrinsical safe signal output circuits, which are provided by two on the IFC 090i-EEx electronics unit installed MODIS modules (see Sect. 1.5 for details).

The regular IFM 5080 K-EEx compact flowmeter as well as the so-called MODIS version type IFM 5080 K/i-EEx is designed for ambient temperatures (T_a) of -20°C up to $+60^{\circ}\text{C}$. The allowed process liquid temperature is limited by the maximum occurring surface temperature of system components in the combustible atmosphere that (possibly) surrounds the apparatus, determined by the temperature class of the atmosphere, see table 1 below.

Temperature classification

Temperature Class	Max. surface Temperature	Maximum process liquid temperature		
		$T_a \leq 40^{\circ}\text{C}$	$T_a \leq 50^{\circ}\text{C}$	$T_a \leq 60^{\circ}\text{C}$
T6	T80°C	60°C	55°C	not allowed
T5	T95°C	75°C	75°C	70°C
T4	T130°C	115°C	115°C	75°C
T3	T165°C	155°C	135°C	75°C

The IFM 5080 K/...-EEx compact flowmeter consists of the IFC 090/...-EEx signal converter unit, which is screwed on top of the IFS 5000-EEx primary head (i.e. measuring unit). The compact flowmeter is marked with the following code below:

II 2 GD EEx dme [jb] IIC T6...T3

In case of the MODIS version IFM 5080 K/i-EEx, the electronics unit of type IFC 090i-EEx is provided with protective modules, which provide intrinsical safe output signals of category "ia". The flowmeter is then marked with the code

II 2 GD EEx dme [jb] [ia] IIC T6...T3

For details see the EC-type Examination Certificate in Sect. 8.2 at the end of these additional instructions.

Primary head

The IFS 5000-EEEx primary head of the IFM 5080 K/...-EEEx compact flowmeter contains two field coils above and below the measuring tube and two electrodes inside the ceramics measuring tube on both sides. The field coils have type of protection increased safety "e" according to EN 50019 and encapsulation "m" according to EN 50028. The electrodes are provided with type of protection intrinsic safety "ib" according to EN 50020.

The primary head is available in meter sizes DN2.5 up to DN100. The IFC 090/...-EEEx signal converter (described in Sect. 1.4-1.5) is mounted on top of the primary head by four recessed head screws of size M6 with internal hexagonal socket set.

Note: The intrinsically safe electrode circuits of the IFM 5080K/...-EEEx compact flowmeter are only internal circuits and not accessible for the customer.

Data plates of ALTOFLUX IFM 5080 K

IFM 5080 K ... EEEx

KROHNE		Kerkeplaat 12 3313 LC Dordrecht The Netherlands		0344
Altometer				
TYPE	IFM 5080 K-EEEx			YEAR OF PRODUCTION
 KEMA 01 ATEX 2262 X II 2GD EEEx dme [b] IIC T6...T3			2002	
			IP65/67 T80...165%DC	
AMBIENT TEMPERATURE: -20...+60%DC.				
SEE CERTIFICATE FOR MAXIMUM TEMPERATURES.				
SERIAL NO.	[]			
POWER	[] Vac	+ [] %	- [] %	[] Vdc ^{+30%} / _{-25%}
	48-63Hz	10VA	Um=253V	8W
INTRINSICALLY SAFE CIRCUITS: ELECTRODE CIRCUIT, ONLY INTERNAL CONNECTIONS. DO NOT OPEN ENCLOSURE WHEN ENERGIZED! WAITING TIME BEFORE OPENING OF THE FLAMEPROOF ENCLOSURE: T6 %%242 20 MIN.; T5 %%242 11 MIN. MAX. SHORT-CIRCUIT CURRENT OF MAINS: A []				
SPACE FOR ADDITIONAL DATA				

IFM 5080 K / i ... EEEx

KROHNE		Kerkeplaat 12 3313 LC Dordrecht The Netherlands		0344
Altometer				
TYPE	IFM 5080 K/i-EEEx			YEAR OF PRODUCTION
 KEMA 01 ATEX 2262 X II 2GD EEEx dme [b] [a] IIC T6...T3			2002	
			IP65/67 T80...165%DC	
AMBIENT TEMPERATURE: -20...+60%DC.				
SEE CERTIFICATE FOR MAXIMUM TEMPERATURES.				
SERIAL NO.	[]			
POWER	<input type="checkbox"/> Term. 24Vac,+10%/-15%,48-63Hz,10W 1L-T0L - 24Vdc,+30%/-25%,10W,Um=253V			
	<input type="checkbox"/> Term. 100...230Vac,+10%/-15% L,N 48-63Hz,8W,Um=253V			
DO NOT OPEN ENCLOSURE WHEN ENERGIZED! WAITING TIME BEFORE OPENING OF THE FLAMEPROOF ENCLOSURE: T6 %%242 20 MIN.; T5 %%242 11 MIN. MAX. SHORT-CIRCUIT CURRENT OF MAINS: A []				
INTRINSICALLY SAFE CIRCUITS Electrode circuit: only internal connections EEx ia IIC %%uTerm.				
<input type="checkbox"/> I/I	Passive output			
<input type="checkbox"/> B1/B1	U _i =30V; I _i =250mA; P _i =1.0W			
<input type="checkbox"/> B2/B2	C _i =5nF; L _i =0; EEx ia IIC			
<input type="checkbox"/> D/D	Passive output			
	U _i =30V; I _i =300mA; P _i =4.2W			
	C _i =5nF; L _i =0; EEx ia IIC			
<input type="checkbox"/> I+/I	Active output			
<input type="checkbox"/> B1+/B1	U _o =23.5V; I _o =98mA; P _o =0.6W			
	C _o =127nF; L _o =4mH; EEx ia IIC			

1.3 VARIFLUX IFM 6080 K ... EEx

The Variflux IFM 6080 K/...-EEx magnetic-inductive compact flowmeter is in accordance with the European Directive 94/9/EC (ATEX 100a) and approved for hazardous classified locations of Zone 1 and 2 under EC-type Examination Certificate number:

KEMA 02 ATEX 2021 X

The compact flowmeter is available in two types, namely:

- IFM 6080 K-EEx regular explosion protected version
- IFM 6080 K/i-EEx, MODIS version. This type has intrinsic safe signal output circuits, which are provided by two on the IFC 090i-EEx electronics unit installed MODIS modules.

The regular IFM 6080 K-EEx compact flowmeter is designed for ambient temperatures (T_a) in the range of -40°C up to $+60^{\circ}\text{C}$, the so-called MODIS version IFM 6080 K/i-EEx is rated for ambient temperatures from -20°C up to $+60^{\circ}\text{C}$. The allowed process liquid temperature is limited by the occurring surface temperature of system components in the combustible atmosphere that (possibly) surrounds the apparatus, determined by the temperature class of the atmosphere, see table.

Temperature classification

Temperature class	Maximum surface Temperature	Maximum process liquid temperature	
		$T_a \leq 50^{\circ}\text{C}$	$T_a \leq 60^{\circ}\text{C}$
T6	$T80^{\circ}\text{C}$	70°C	70°C
T5	$T95^{\circ}\text{C}$	85°C	85°C
T4	$T130^{\circ}\text{C}$	120°C	100°C
T3	$T190^{\circ}\text{C}$	180°C	100°C

The regular IFM 6080 K-EEx compact flowmeter consists of the IFC 090-EEx signal converter, which is screwed on top of the IFS 6000-EEx primary head (i.e. measuring unit). The compact flowmeter is marked with the following code below, depending on the meter size:

- DN2.5-15: II 2GD EEx dme [ib] IIC T6...T3
- DN25-80: II 2GD EEx d [ib] IIC T6...T3 ("EEx d" terminal compartment) or II 2GD EEx de [ib] IIC T6...T3 ("EEx e" terminal compartment)
- DN2.5-15: II 2GD EEx dme [ib] [ia] IIC T6...T3
- DN25-80: II 2GD EEx d [ib] [ia] IIC T6...T3 ("EEx d" terminal compartment) or II 2GD EEx de [ib] [ia] IIC T6...T3 ("EEx e" terminal compartment)

All meters are also marked with the maximum surface temperature $T80...T190^{\circ}\text{C}$ because of the dust classification. See for details the EC-type examination certificate in Sect. 8.3 of these additional instructions.

Primary head

The IFS 6000-EEx primary head of the IFM 6080 K/...-EEx compact flowmeter contains two field coils and two electrodes in type of protection intrinsic safety category "ib" according to EN 50020. The type of protection of the field coils depends on meter size.

Types of protection of primary head

Meter size	Type of protection
DN2.5 up to DN15	Field coils: Increased safety "e" according to EN 50019 Encapsulation "m" according to EN 50028 Electrodes: Intrinsic safety "ib" according to EN 50020
DN25 up to DN80	Housing: Flameproof enclosure "d" according to EN 50018 Electrodes: Intrinsic safety "ib" according to EN 50020

The IFC 090/...-EEx signal converter (described in Sect. 1.4-1.5) is mounted on top of the primary head by four recessed head screws of size M6 with internal hexagonal socket set.



Note

The intrinsically safe electrode circuits of the IFM 6080K/...-EEx compact flowmeter are only internal circuits and not accessible for the customer.



The two field coils inside the primary head are connected in series and provided with the type of protection increased safety "e" and encapsulation "m" (DN2.5-15). Meter size DN25-80 has a flameproof primary housing.

Data plates of ALTOFLUX IFM 6080 K

IFM 6080 K ... EEx

KROHNE		Kerkeplaat 12 3313 LC Dordrecht The Netherlands			0344
Altometer					
TYPE		IFM 6080 K-EEx		YEAR OF PRODUCTION	
		KEMA 02 ATEX 2021 X		2002	
<input type="checkbox"/> II 2GD EEx d		<input type="checkbox"/> [ib] IIC T6...T3		IP65/67	
				T80...190%/DC	
AMBIENT TEMPERATURE: -40...+60%/DC.					
SEE CERTIFICATE FOR MAXIMUM TEMPERATURES.					
SERIAL NO. <input type="text"/>					
POWER		<input type="checkbox"/> Vac + <input type="checkbox"/> % - <input type="checkbox"/> % <input type="checkbox"/> Vdc +30% -25%			
48-63Hz		10VA Um=253V		8W	
INTRINSICALLY SAFE CIRCUITS: ELECTRODE CIRCUIT, ONLY INTERNAL CONNECTIONS.					
DO NOT OPEN ENCLOSURE WHILE ENERGIZED!					
WAITING TIME BEFORE OPENING OF THE FLAMEPROOF ENCLOSURE: T6 % \leq 242 20 MIN.; T5 % \leq 242 11 MIN.					
MAX. SHORT-CIRCUIT CURRENT OF MAINS: <input type="text"/> A					
SPACE FOR ADDITIONAL DATA					

IFM 6080 K / i ... EEx

KROHNE		Kerkeplaat 12 3313 LC Dordrecht The Netherlands			0344
Altometer					
TYPE		IFM 6080 Ki-EEx		YEAR OF PRODUCTION	
		KEMA 02 ATEX 2021 X		2002	
<input type="checkbox"/> II 2GD EEx d		<input type="checkbox"/> [ib] [ia] IIC T6...T3		IP65/67	
				T80...190%/DC	
AMBIENT TEMPERATURE: -20...+60%/DC.					
SEE CERTIFICATE FOR MAXIMUM TEMPERATURES.					
SERIAL NO. <input type="text"/>					
POWER		<input type="checkbox"/> Term. 24Vac, +10%/-15%, 48-63Hz, 10W			
		1L  24Vdc, +30%/-25%, 10W, Um=253V			
		<input type="checkbox"/> Term. 100...230Vac, +10%/-15%			
		L, N 48-63Hz, 8W, Um=253V			
DO NOT OPEN ENCLOSURE WHILE ENERGIZED!					
WAITING TIME BEFORE OPENING OF THE FLAMEPROOF ENCLOSURE: T6 % \leq 242 20 MIN.; T5 % \leq 242 11 MIN.					
MAX. SHORT-CIRCUIT CURRENT OF MAINS: <input type="text"/> A					
INTRINSICALLY SAFE CIRCUITS					
Electrode circuit: only internal connections				EEx b IIC	
% \leq uTerm.					
<input type="checkbox"/>	H	Passive output			
<input type="checkbox"/>	B1/B1	U _i =30V; I _i =250mA; P _i =1.0W			
<input type="checkbox"/>	B2/B2	C _i =5nF; L _i =0;	EEx ia IIC		
<input type="checkbox"/>	DD	Passive output			
<input type="checkbox"/>		U _i =30V; I _i =300mA; P _i =4.2W			
<input type="checkbox"/>		C _i =5nF; L _i =0;	EEx ia IIC		
<input type="checkbox"/>	I+/I	Active output			
<input type="checkbox"/>	B1+/B1	U _o =23.5V; I _o =98mA; P _o =0.6W			
<input type="checkbox"/>		C _o =132nF; L _o =4mH;	EEx ia IIC		

1.4 IFC 090/...-EEx signal converter

The IFC 090/...-EEx signal converter consists of a cylindrical housing of die-casted aluminum, which has two separate compartments, divided from each other by an integrated wall with casted flameproof terminal feed-through. The neck at the bottom of the housing contains a flameproof cable feed-through. The signal converter housing is on both ends closed by a cylindrical threaded cover with O-ring sealing. The housing has an ingress protection degree of at least IP67 conform to EN 60529.

1.4.1 Electronics compartment

The electronics compartment accommodates the pre-certified IFC 090...-EEx electronics unit with approval number PTB 98 ATEX 2012 U. The electronics compartment is designed with type of protection flameproof enclosure "d" according to EN 50018. It is closed by a threaded flameproof display cover with glass window.

1.4.2 Terminal compartment

The terminal compartment has seven terminals for connection of the power supply and signal output circuits. Sect. 2 (Connection diagram) shows the terminal arrangement for the regular and MODIS version of the IFC 090/...-EEx signal converter. The terminal arrangement of the MODIS version (i.e. IFC 090i-EEx) is shown in Sect. 2 (Modis Converter). Two of the terminals are used for connection of the non-intrinsically safe power supply and four terminals (marked with "**") for the intrinsically safe, category "ia" signal outputs of the MODIS modules. The non-intrinsically and intrinsically safe terminals are separated from each other by a metal dividing plate, which is screwed to the remaining (not connected) M4 terminal. The two non-intrinsically safe power supply terminals are covered by an insulating plate.

The terminal compartment (with standard type of protection increased safety "e") is standard equipped with two ATEX approved "EEx e" cable glands. The terminal compartment can also be provided as a flameproof enclosure "d", in which case ATEX approved "EEx d" cable glands of size Pg13.5, Pg16 or M20x1.5 are either factory installed or must be installed by the customer. For flameproof conduit systems, the terminal compartment must have type of protection flameproof enclosure "d" according to EN 50018. The conduits must be sealed by "EEx d" approved (within the ATEX 100a directive) sealing devices (i.e. stopping box) directly at the conduit entrances of the as flameproof enclosure performed terminal compartment.

1.5 Electronics unit

This electromagnetic compact flowmeter can be equipped with the regular IFC 090-EEEx or with the IFC 090i-EEEx electronics unit with intrinsically safe signal outputs (i.e. MODIS version). This version is described in the following.

Regular IFC090-EEEx electronics unit

The IFC 090-EEEx is used in the regular IFM 4080 K-EEEx and can be equipped with one of the following power supplies (depends on the area of application).

Electrical data for power supply

Power supply	Terminal	Function	Electrical data
AC-versions	L N PE	Live Neutral Protective Ground	$U_n = 100/115/200/230 V_{ac} -15/+10\%$ $P_n = \text{approx. } 10 \text{ VA}, U_m = 253 \text{ V}$
AC/DC-version	1L ⊕ 0L ⊕ FE	Live Neutral Functional Ground	$U_n = 24 \text{ V ac/dc}$ AC: $-15/+10\%$, $P_n=10 \text{ VA}$ DC: $-25/+30\%$, $P_n=8 \text{ W}$ $U_m = 253 \text{ V}$

The IFC 090-EEEx electronics unit is equipped with the following in-/output circuits. Terminals B1, B_⊥ and B2 can be configured as status or pulse outputs or as control inputs via the software. See the table below for the electrical data of these in-/output circuits.

Electrical data of in-/output circuits

Terminals	Description	Nominal voltage	Maximum current
I+, I	Current output	15 V	22 mA
B1, B [^] , B2	Pulse, status, control in-/outputs	32 V	150 mA

IFC 090i-EEEx unit with MODIS modules

The IFC 090i-EEEx electronics unit is equipped with a pair of MODIS-modules. It is equipped with one of the following power supplies.

Electrical data of IFC 090i-EEEx electronics unit

Power supply	Terminals	Function	Electrical data
AC-version	L N PE	Live Neutral Protective Ground	$U_n = 100...230 V_{ac} -15\%/+10\%$ $P_n = 15 \text{ VA}, U_m = 253 \text{ V}$
AC/DC-version	1L ⊕ 0L ⊕ FE	Live Neutral Functional Ground	$U_n = 24 V_{ac/dc}$ AC: $-15\%/+10\%$ or $20.4...26.4 V_{ac}$ DC: $-25\%/+30\%$ or $18...32 V_{dc}$ $P_n = 10 \text{ W}, U_m = 253 \text{ V}$

NOTE: The mains fuses for both electronics units are listed in Sect. 6 of this manual.

2 Electrical connection

2.1 Equipotential bonding system

All EEx and EEx/i flowmeters must always be incorporated into the equipotential bonding system of the hazardous area. This connection can be achieved through the PE/FE conductor connected to the PE terminal in the terminal compartment (see figure of terminal arrangement below) or through a separate PE conductor, cross sectional area at least 4 mm^2 , connected to the external PE clamp, placed below the converter housing.

2.2 Connecting cables

NOTE: The below described cables are shown in the following connection diagram .

Cable A:

Signal cable for current output and binary outputs (pulse and status output): The cable parameters must be in accordance with the regulations in the EN 60079-14 "Electrical installations in hazardous locations" or an equivalent national standard. For the MODIS version with IFC 090i-EEx electronics unit (right detail in connection diagram) the signal cable for the intrinsically safe signal in-/outputs must also conform the requirements as specified in the relevant standard national code of practice for the installation of electrical apparatus with type of protection Intrinsic Safety "i".

Cable B:

Power supply cable: The cable parameters must be in accordance with the regulations of the EN 60079-14 "Electrical installations in hazardous locations" or an equivalent national standard.

Rated voltage	$\geq 500 \text{ V}$
Examples:	H07...-, H05...-.
Equipotential bonding conductor Cross-sectional area:	4 mm^2 (equivalent to AWG 10)

2.3 Connection diagram

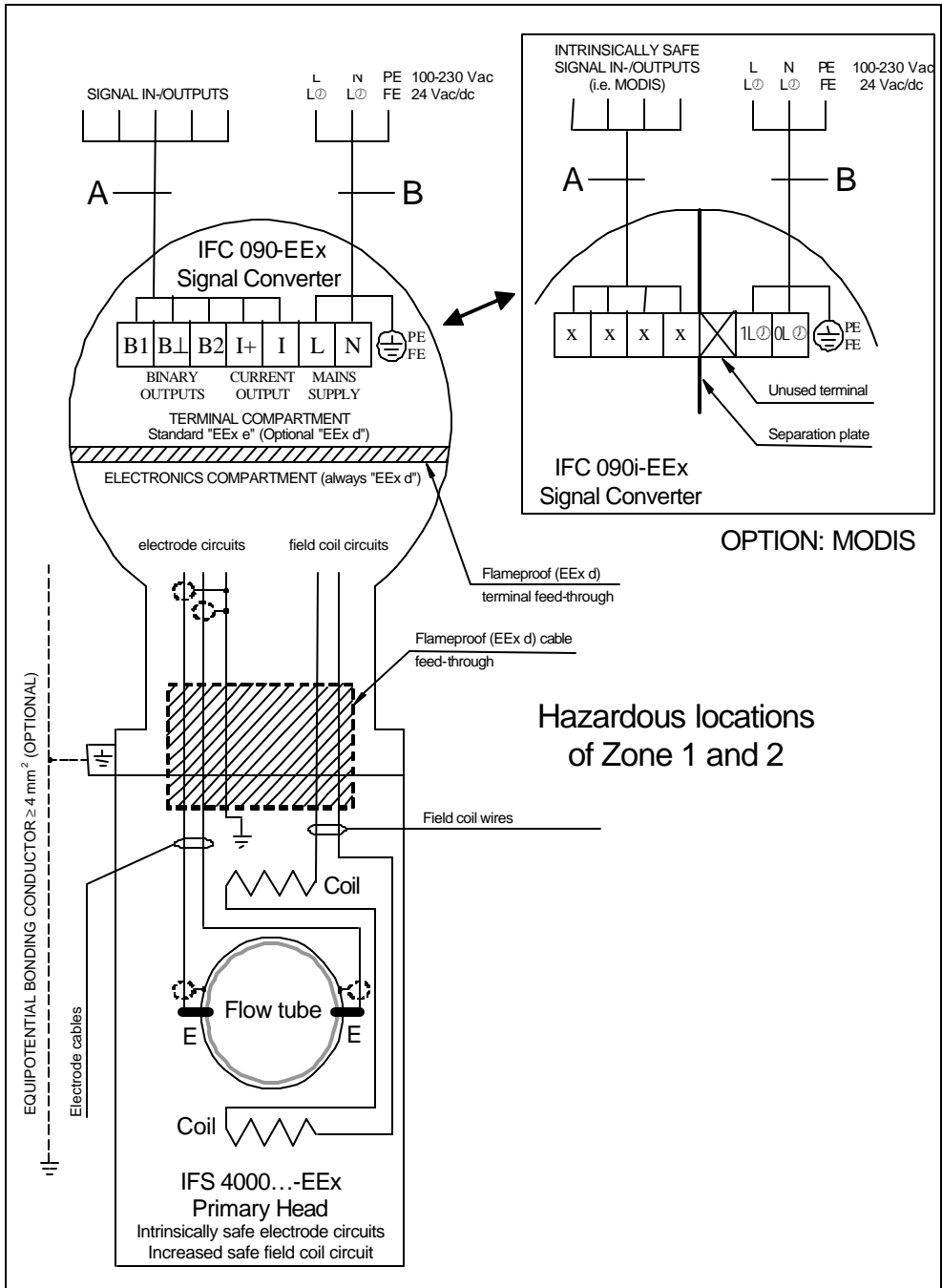

2.4 Regular IFC 090-EEEx electronics unit

The field cables that enter the terminal compartment of the IFC 090-EEEx signal converter unit (i.e. power supply, current and binary outputs) are non-intrinsically safe. To connect external devices to the signal output terminals, the wiring requirements for the type of protection of the compartment (standard: increased safety "e", international or national standard involved (e.g. IEC 60079-14)) must be conform to the international or national standard involved (e.g. IEC 60079-14).
The terminal arrangement is shown by figure 1 below.

Terminal arrangement in terminal compartment

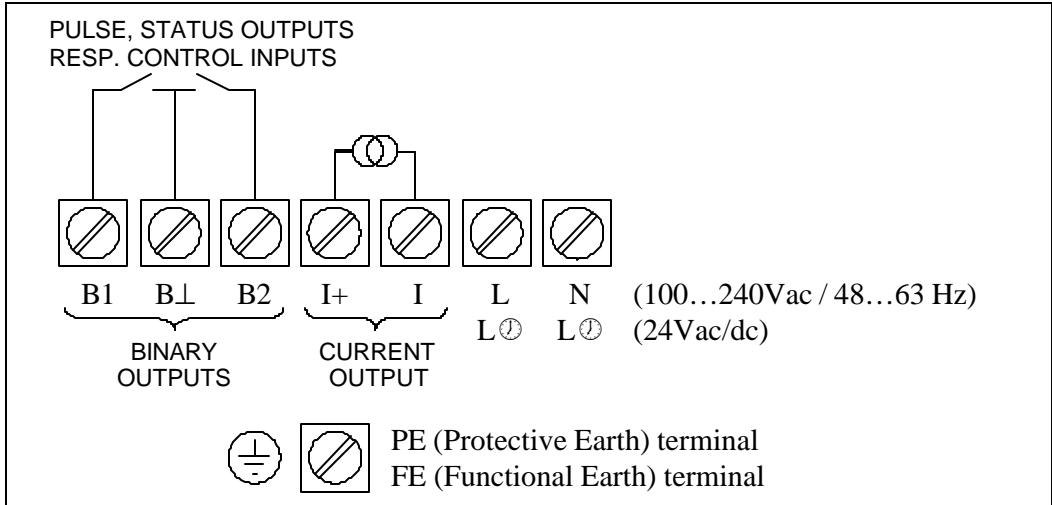

Passive pulse/status output

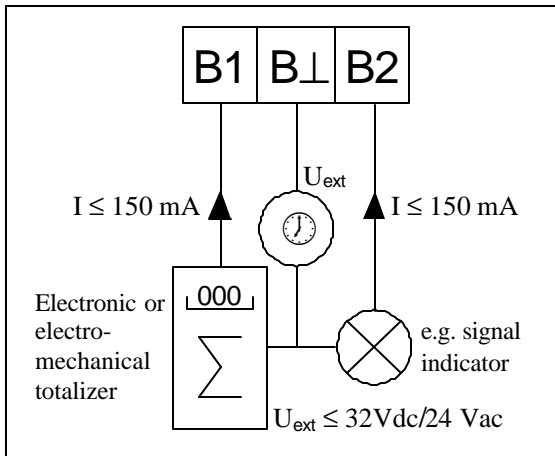

Active current output

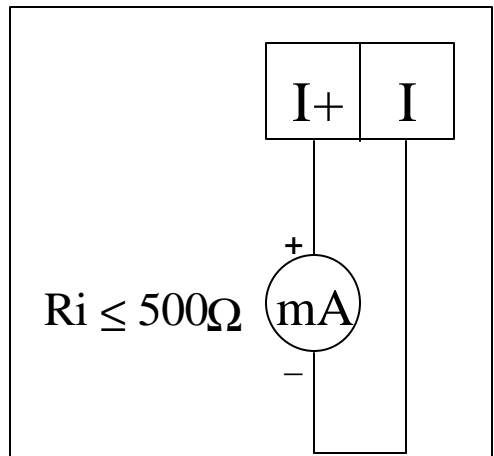

Note: The binary outputs (terminals B1, B┐ and B2) can only be configured as passive outputs, the current output (terminals I+ and I) can only be configured as active output.

2.5 MODIS version IFC 090i-EEEx electronics unit

The field cables of the non-intrinsically safe power supply and the intrinsically safe, category "ia" signal outputs enter the terminal compartment of the IFC 090i-EEEx signal converter unit via two separate entrances. To connect external devices to the intrinsically safe signal output terminals, the wiring requirements for their type of protection as well as of the compartment (standard: increased safety "e", optional: flameproof enclosure "d") must be conform to the international or national standard involved (e.g. EN 60079-14).

Terminal arrangement in terminal compartment

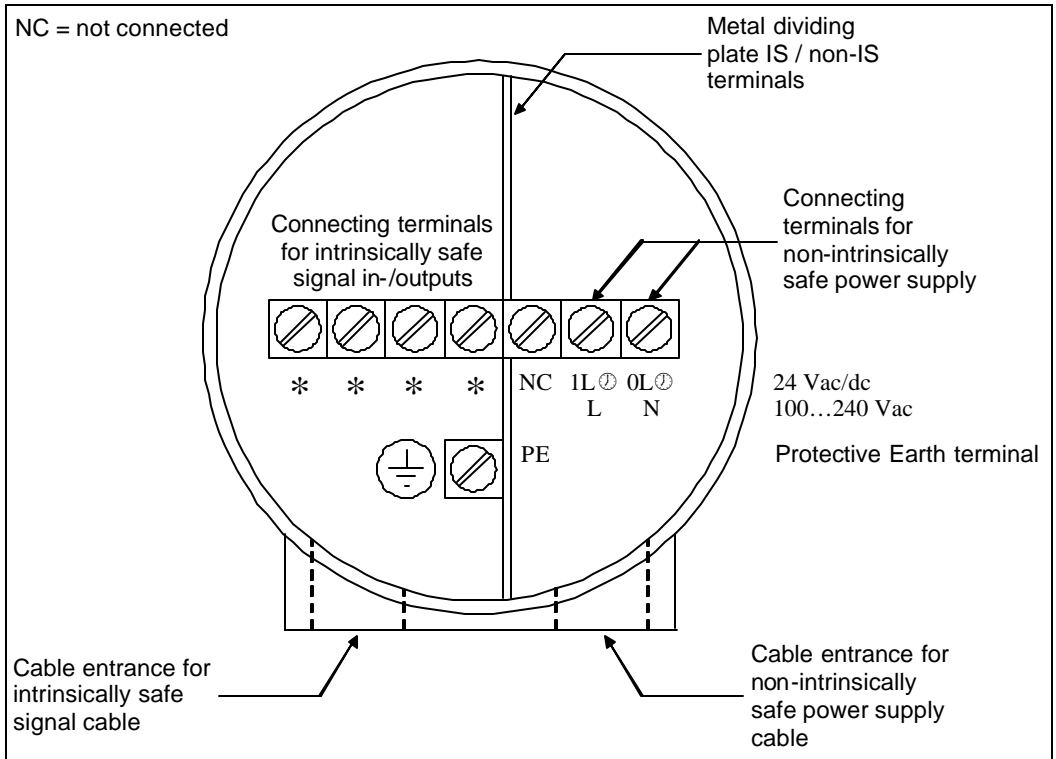

The non-intrinsically safe terminals for connection of the power supply (1L⚡ and 0L⚡) must be connected according to the relevant standard code of practice for electrical apparatus intended for use in potentially hazardous locations, type of protection Increased Safety "e" or type of protection Flameproof Enclosure "d", depending on the type of protection of the terminal compartment of the signal converter housing.

To gain access to the connection terminals of the power supply, the half-circular cover plate of insulating material must be slightly lifted at one end and then rotated downwards, see the instruction on the cover plate. After connection of the power supply cable, the half-circular cover plate must be restored into its original position, so that the minimum clearances and creepage distances towards the intrinsically safe signal in-/output terminals are maintained.

For details, see diagram on terminals compartment MODIS on next page.

Terminal compartment MODIS version IFC 090i-EEEx

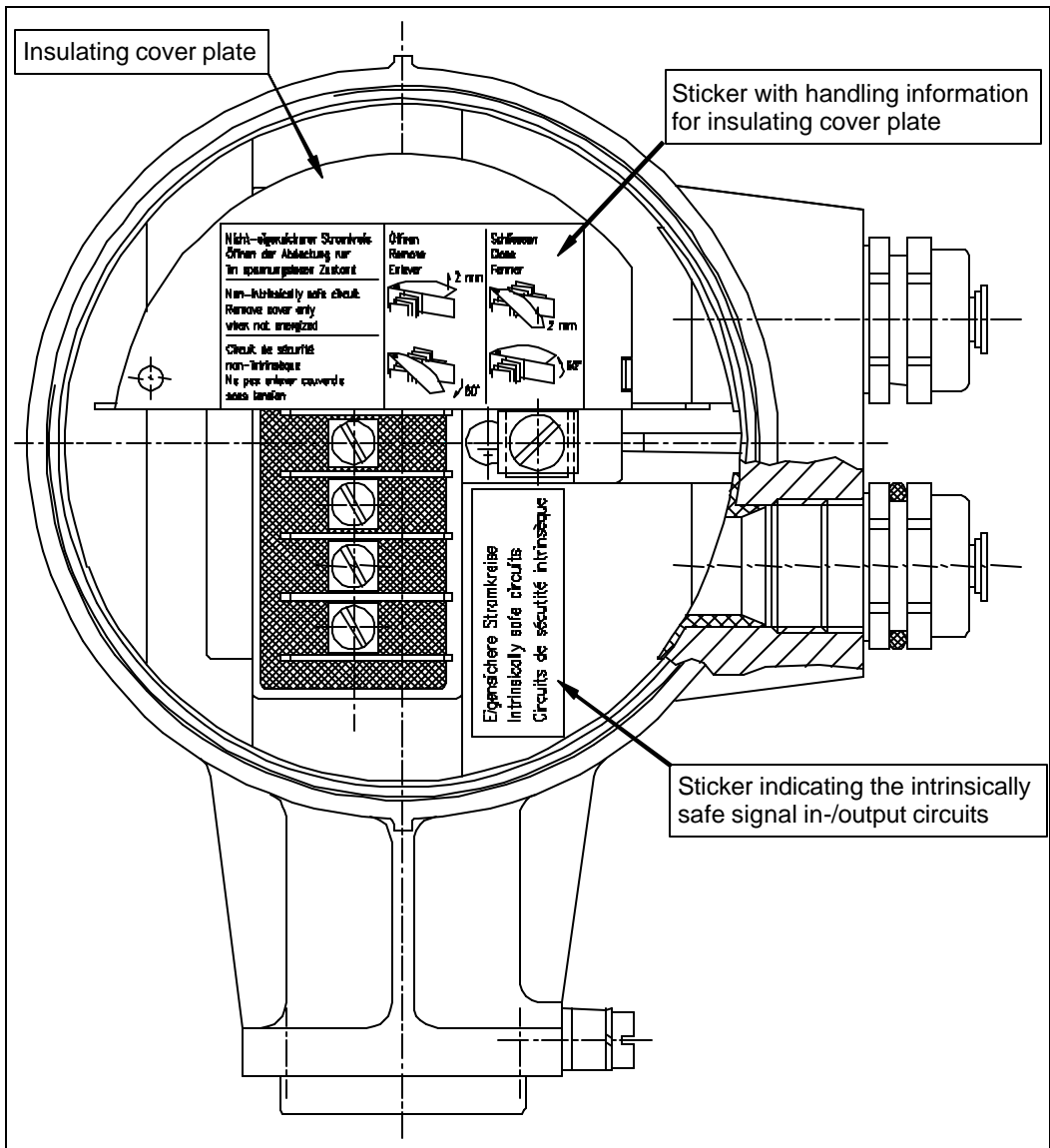

The PE (or FE) conductor must be connected to the press-fitted M5 clamp terminal marked inside the terminal compartment. This conductor must be guided through the rectangular opening in the metal dividing plate that separates the non-intrinsically safe power supply terminals from the intrinsically safe signal in-/output terminals.

2.6 Connection diagrams MODIS

Sect. 2.3 shows the block diagram of the EEx electromagnetic compact flowmeter. The power supply (terminals 1L ⊕, 0L ⊕) is connected via cable B. The PE terminal must be connected to the protective ground conductor of the mains supply.

The IFC 090i-EEEx electronics unit is provided with intrinsically safe signal in-/output circuits due to the installed pair of MODIS modules in accordance with the table below.

Overview of MODIS modules

Module	Terminal designation	Function / Intrinsically safe maximum data
P-SA	I ⊥, I	Current output (0/4-20 mA), passive $U_i = 30 \text{ V}$, $I_i = 250 \text{ mA}$, $P_i = 1.0 \text{ W}$ $C_i = 5 \text{ nF}$, $L_i \approx 0$
FA-ST	B1, B1 ⊥ or B2, B2 ⊥	Pulse (frequency) output or status in-/output, all passive The function can be set by software $U_i = 30 \text{ V}$, $I_i = 250 \text{ mA}$, $P_i = 1.0 \text{ W}$ $C_i = 5 \text{ nF}$, $L_i \approx 0$
F-PA	D, D ⊥	Fieldbus module, type Profibus system, passive $U_i = 30 \text{ V}$, $I_i = 300 \text{ mA}$, $P_i = 4.2 \text{ W}$ $C_i = 5 \text{ nF}$, $L_i \approx 0$
F-FF	D, D ⊥	Fieldbus module, type Fieldbus Foundation, passive $U_i = 30 \text{ V}$, $I_i = 300 \text{ mA}$, $P_i = 4.2 \text{ W}$ $C_i = 5 \text{ nF}$, $L_i \approx 0$
DC-I	I+, B1+	Intrinsically safe voltage source for the passive module P-SA or FA-ST, so that active operation is possible. $U_o = 23.5 \text{ V}$, $I_o = 98 \text{ mA}$, $P_o = 0.6 \text{ W}$ $C_o = 132 \text{ nF}$, $L_o = 4 \text{ mH}$ Note! When modules P-SA (or FA-ST) and DC-I are connected in series, the internal capacitance C_i of 5 nF must be subtracted from the C_o of 132 nF. So the data plate will list a C_o of 127 nF.

Besides the shown intrinsically safe maximum values for voltages and current -which are based on certain fault conditions as prescribed by the standard EN 50 020 - the nominal values for current and voltage must also be respected otherwise a proper functioning of the modules is not guaranteed!

Nominal voltage and current values for the MODIS modules

MODIS module	Nominal values for voltage and current	
P-SA (passive current output)	Current:	4 ... 20 mA
	Working voltage:	8 ... 30V
	Voltage drop :	8V at 4mA
FA-ST (frequency / pulse / status output or control input)	Working voltage:	6 ... 30V
	Working current:	< 110 mA
	Voltage drop: in ON-state:	< 2V at 110 mA
	Leakage current in OFF-state:	< 900 µA at 30V
	Control input:	
	Input voltage LOW level:	< 3V
	Input voltage HIGH level:	> 7V
	Frequency range :	0 .. 12 KHz
DC-I (active voltage source)	Voltage:	20V
	Current	30 mA
	Internal resistance:	260

The active module DC-I is needed in the 24 Vac/dc power supply version to form an active current or pulse output in combination with one of the passive modules P-SA or FA-ST. Due to limited space it is not available for 100...230 Vac supply versions.

Possible combinations of the installed MODIS modules for the 24 Vac/dc power supply version of the IFC 090i-EEx

IFC 090i-EEx version	Part No.	MODIS modules		Terminal designation			
Ex-i1	2.11582.01.00	P-SA	FA-ST	I ⊥	I	B1	B1 ⊥
Ex-i2	2.11582.03.00	P-SA	F-PA	I ⊥	I	D	D ⊥
Ex-i3	2.11582.02.00	P-SA	DC-I	I+			I
Ex-i4	2.11582.05.00	FA-ST	F-PA	B1	B1 ⊥	D	D ⊥
Ex-i5	2.11582.06.00	FA-ST	DC-I	B1+			B1
Ex-i6	2.11582.07.00	FA-ST	FA-ST	B2	B2 ⊥	B1	B1 ⊥
Ex-i7	2.11582.08.00	P-SA	F-FF	I ⊥	I	D	D ⊥
Ex-i8	2.11582.09.00	FA-ST	F-FF	B1	B1 ⊥	D	D ⊥

Possible combinations of the installed MODIS modules for the 100-230 Vac power supply version of the IFC 090i-EEx

IFC 090i-EEx version	Part No.	MODIS modules		Terminal designation			
Ex-i1	2.12253.01.00	P-SA	FA-ST	I ⊥	I	B1	B1 ⊥
Ex-i2	2.12253.02.00	P-SA	F-PA	I ⊥	I	D	D ⊥
Ex-i4	2.12253.03.00	FA-ST	F-PA	B1	B1 ⊥	D	D ⊥
Ex-i6	2.12253.04.00	FA-ST	FA-ST	B2	B2 ⊥	B1	B1 ⊥
Ex-i7	2.12253.05.00	P-SA	F-FF	I ⊥	I	D	D ⊥
Ex-i8	2.12253.06.00	FA-ST	F-FF	B1	B1 ⊥	D	D ⊥

Due to mechanical and electrical limitations, only the listed pairs of MODIS modules are possible. The two modules each use two terminals of the bottom four terminals of the flameproof terminal feed-through in the dividing wall between the electronics and terminal compartment of the signal converter housing, except for the combination with module DC-I (only applicable for 24 Vac/dc versions), where only two of the four terminals are used. Interconnection of the two modules, P-SA with DC-I or FA-ST with DC-I is made internally.

The flameproof terminal feed-through has seven terminals in total, the top two terminals are used for connection of the power supply, the third one is only used for mounting of a metal dividing plate with insulating cover plate. The remaining four are used for the intrinsically safe signal in-/output circuits of the installed MODIS modules.

The metal dividing plate and the insulating cover plate warrant the required separation distances (i.e. clearances, creepage distances and distances through insulation) between the non-intrinsically safe power supply terminals and the intrinsically safe signal in-/output circuits. The insulating cover plate is provided with a sticker that contains important instructions how to remove and re-install the cover plate and the conditions under which it should be established (circuits not live!).

Important ! Carefully follow the instructions on the sticker that is glued to the top of the insulating cover plate that covers the non-intrinsically safe power supply terminals !

For the connection diagrams of the intrinsically safe signal in-/outputs of the installed MODIS modules in the IFC 090i-EEEx electronics unit (see figure 6, 7 and 8 on the following pages). It has to be noted that the intrinsically safe signal in-/outputs may only be connected to the following listed apparatus' (registering devices like amp-meters, pulse counters, etc.):

EEEx-approved intrinsically safe apparatus;

EEEx-approved associated apparatus;

Passive apparatus as defined in your national standard for installation of electrical apparatus in hazardous locations (e.g. EN 60079-14).

Other types of apparatus may only be connected to the intrinsically safe signal in-/outputs through EEx-approved safety barriers, isolating interface units and the like. These barriers or units are not depicted in the connection diagrams of figure 6, 7 and 8 for reasons of readability. It is assumed that they are an integrated part of the registering devices or as separate devices connected in series with them. The registering devices may only be installed in the hazardous location if they also have a type of protection for explosion safety according to the European Standards of the EN 500xx series, or if they are constructed as prescribed in your standard national code of practice.

When the intrinsically safe signal in-/outputs are connected to other intrinsically safe or associated apparatus, the maximum safety values (i.e. entity parameters) of all intrinsically safe circuits have to be considered.

Important !	The 100...230 Vac power supply versions of the IFC 090i-EEEx signal converter electronics unit with MODIS modules can only be equipped with passive outputs. Therefore the connection diagrams with the numbers 2, 4, 5, 7, 9, 11 and 12 are applicable for the 100...230 Vac power supply versions.
--------------------	--

Connection diagrams 1 to 4 of the intrinsically safe signal in-/outputs

① Current output I active

Version: Ex-i3
 $I = 4..20\text{mA}$
 $R_I \leq 350\Omega$

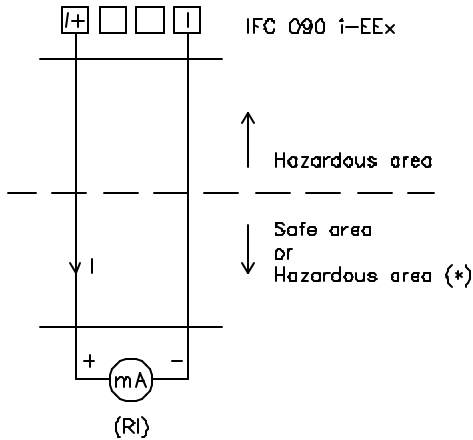

② Current output I passive

Versions: Ex-i1, Ex-i2 and Ex-i7
 $U_{\text{ext}} = 8..30\text{V}$
 $R_I \leq (U_{\text{ext}} - 8) / 0.022$
 $I = 4..20\text{mA}$

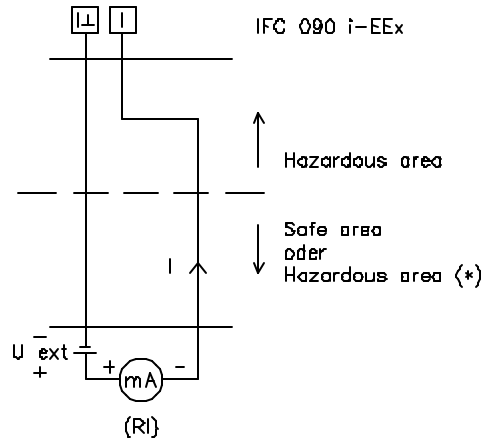

③ Pulse output P active

Version: Ex-i5
 $U_{\text{int}} = 20\text{V DC}$
 $R_{\text{int}} = 260\Omega$
 $U_I = 20 \cdot R_I / (260 + R_I)$

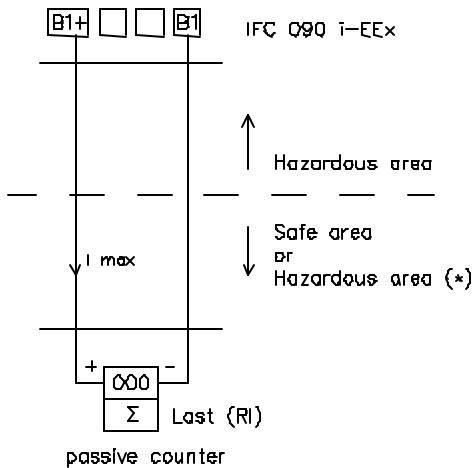

④ Pulse output P passive

Versions: Ex-i1, Ex-i4, Ex-i6 and Ex-i8
 $U_{\text{ext}} = 6..30\text{V DC}$
 $I_{\text{max}} \leq 110\text{mA}$

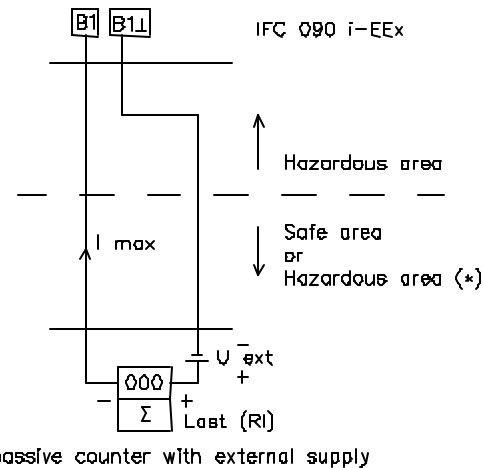

(*) Important note:
 Only if the measuring devices are also explosion protected!

Connection diagrams 5 to 8 of the intrinsically safe signal in-/outputs

5 Pulse output P passive

Versions: Ex-11, Ex-14, Ex-16 and Ex-18
 $U_{ext} = 6..30V\ DC$
 $I_{max} \leq 110mA$
 for active EC

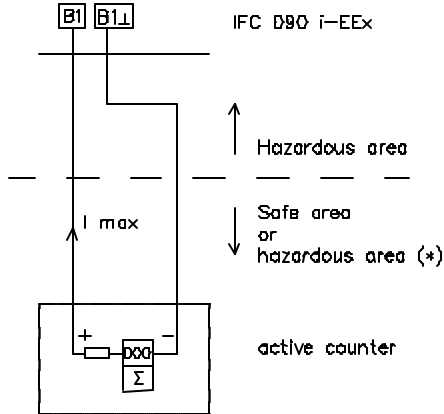

6 Status output S active

Version: Ex-15
 $U_{int} = 20V\ DC$
 $R_{int} = 260\ \Omega$
 $U_I = 20.R_I / (260 + R_I)$

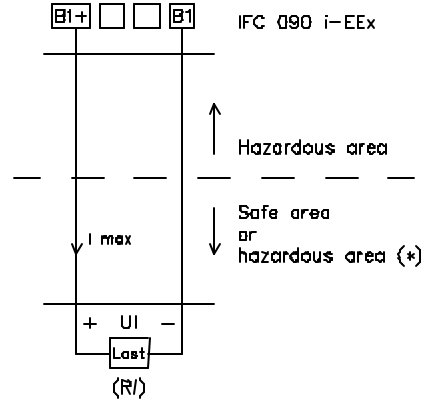

7 Status output S passive

Connection to B1/B1L and/or B2/B2L
 Versions: Ex-11, Ex-14, Ex-16 and Ex-18
 $U_{ext} = 6..30V\ DC$
 $I_{max} \leq 110mA$

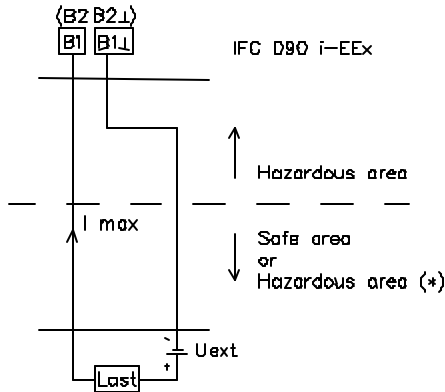

8 Control input C active

Version: Ex-15
 $U_{int} = 20V\ DC$
 $I_{contact} \leq 6\ mA$

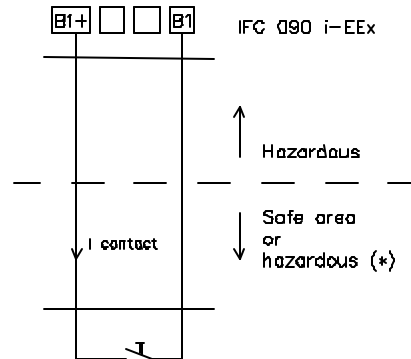

(*) Important note:
 Only when the measuring devices are also explosion protected!

Connection diagrams 9 to 12 of the intrinsically safe signal in/outputs

9 Control Input C passive

Connection to B1/B1L and/or B2/B2L
 Versions: Ex-I1, Ex-I4, Ex-I6 and Ex-I8
 $U_{ext} = 7..30 \text{ V DC}$

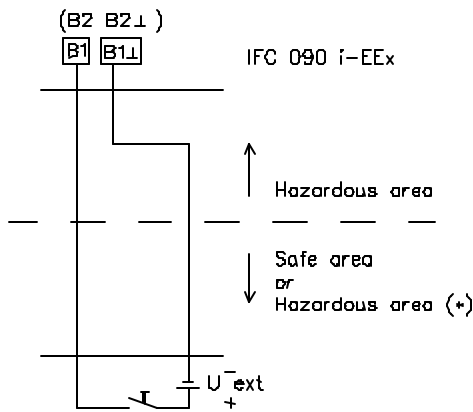

10 HART active

Version: Ex-I3

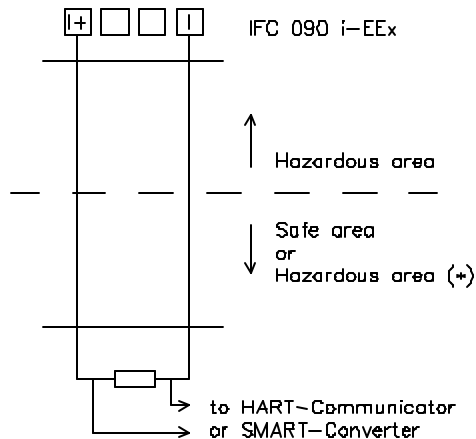

11 HART passive

Versions: Ex-I1, Ex-I2 and Ex-I7

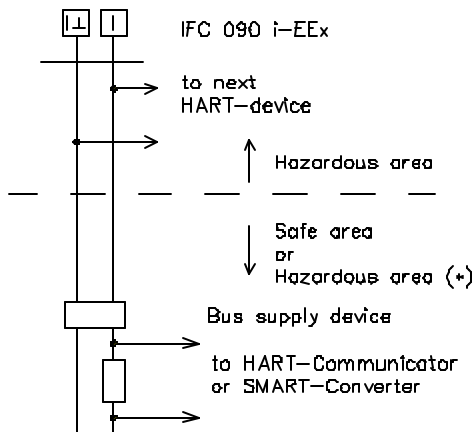

12 Fieldbus

Versions: Ex-I2, Ex-I4, Ex-I7 and Ex-I8

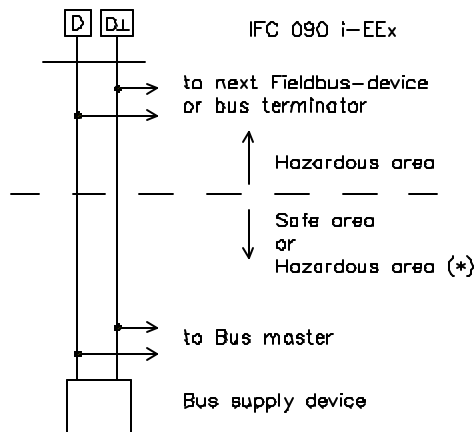

(*) Important note:
 Only when the devices are also explosion protected!

3 Operation of the signal converter

The i-EEEx compact flowmeters are always equipped with magnet sensors. In that way it is possible to change the settings of the converter with aid of the magnet-bar without the necessity to open the flameproof converter housing in the hazardous area.

For the program functions and settings of the converter the standard Installation and operating instructions have to be consulted. It must be noted that - depending on the IFC090 i-EEEx version installed - not all output/input functions are available.

Following menus do not apply for the IFC090 i-EEEx versions Ex-i2 and Ex-i3:
(see also Sect. 4.4. "Table of settable functions" in the standard "Installation and operating instructions" of the IFC090 K/F signal converter)

1.01 → VALUE P	1.06 PULS B1	1.06 CONTROL B1	3.02 → VALUE P
1.06 Output/input B1	1.06 STATUS B1	1.07 CONTROL B2	3.07 HARDWARE
1.07 Output/input B2	1.07 STATUS B2		

Fct.		Text	Description and settings
1.00	1.00	OPERATION	Operations menu
	1.01	FULL SCALE	...
		→ VALUE P	
	1.06	Output/Input B1	
	1.07	Output/Input B2	
	1.06	PULS B1	
	1.06	STATUS B1	
	1.07	STATUS B2	
	1.06	CONTROL B1	
	1.07	CONTROL B2	
3.00	3.00	INSTALL.	Installation menu
	3.02	FLOWMETER	...
		→ VALUE P	
	3.07	HARDWARE	

As a consequence, the chapters included in the standard Installations and operating instructions, giving detailed descriptions of these menus, must be skipped.

4 Maintenance

The IFM x080 K/...-EEEx electromagnetic compact flowmeters are maintenance free with regard to the flowmetering properties. Within the scope of the periodical inspections, which are required for electrical apparatus that are installed and used in hazardous classified locations, it is recommended to check the flameproof enclosure on signs of damage or corrosion. This concerns the converter housing.

5 Service

See Sect. 5 or contact your (local) KROHNE sales representative for the ordering information of spare parts or replacements of IFC 090...-EEx electronics units and/or power fuses.

5.1 General information for replacements

IMPORTANT !	The following instructions must be followed carefully, if the IFC 090/...-EEx signal converter housing has to be opened respectively closed again!
--------------------	--

Before opening

Make absolutely sure there is no explosion hazard!

If necessary provide a "Gas-free certificate" !

Make sure that all connecting cables are safely isolated from the power supply !

When the instructions above are strictly followed, the cover (with glass window) of the electronics compartment may be removed. First unscrew the recessed head screw of the interlocking device by a hollow-head screw wrench size 3, until the cover can rotate freely. Unscrew the cover with the special plastic wrench (black) that is supplied with the apparatus.

After opening

The copper ground strip at the back of the electronics unit must be securely screwed to the housing (back-end of electronics compartment) by screw SE (see figure 9 below). The electronics unit is screwed into the electronics compartment by two screws D. Before screws SE and D can be accessed, the display unit must be removed via screws A.

Before the cover is screwed back into the housing, the screw-thread must be clean and well-greased with an acid and resin-free grease, e.g. silicone grease.

Screw the cover as tight as possible into the housing by hand, until it cannot be opened by hand anymore. Screw the recessed head screw of the interlocking device tight.

IFC 090-EEx electronics unit after removal of display unit

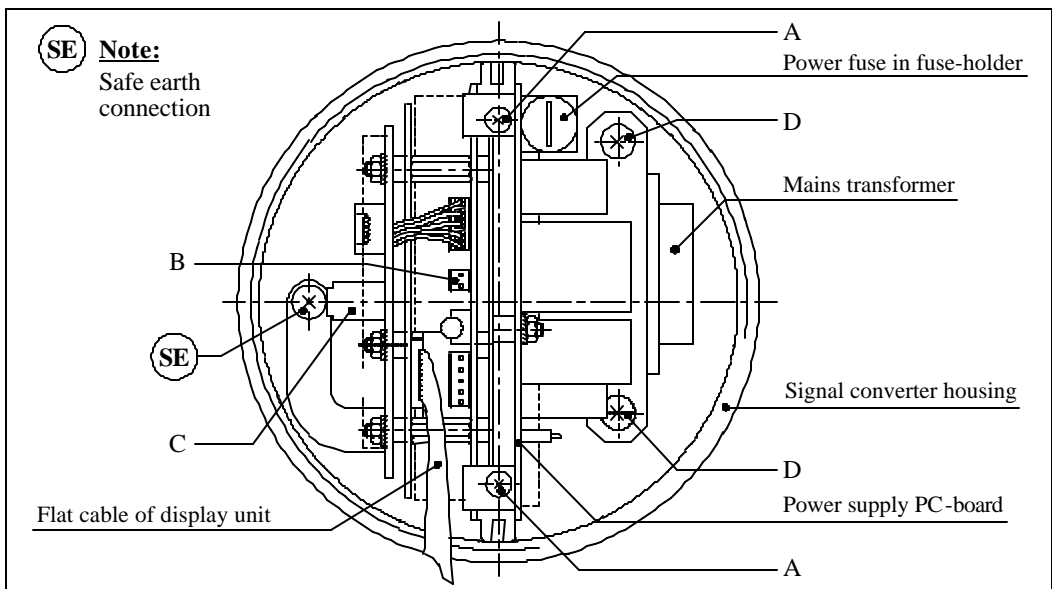

5.2 Replacement of electronics unit

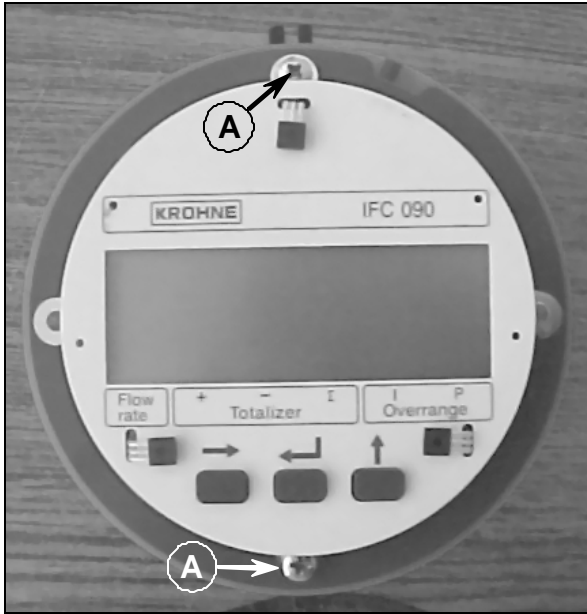

Display unit of IFC 090...-EEx

Refer to the standard Installation and Operating Instructions for detailed information about resetting and reprogramming the new electronics unit after replacement. The customer specific data (like the value of the internal totalizer) are stored in DATAPROM IC-18, which must be transferred from the "old" to the "new" electronics unit. See Sect. 8.7 of the standard Installation and Operating Instructions for detailed information.

Before commencing work, note the instructions in Sect. 5.1 ("Before opening").

Then continue as follows:

1. Remove the display cover of the electronics compartment.
2. Unscrew the two screws A (M3) of the display unit (see figure 10) and turn it carefully aside.
3. Disconnect the 2-pole field circuit connector (item B in figure 9) and the 3-pole electrode circuit connector (item C). See figures in Sect. 5.1 and the following.
4. Unscrew the two mounting screws D of the electronics unit and unscrew SE, which fixes the copper ground strip to the back of the housing. A screwdriver with a long shaft (≥ 200 mm) is most suitable for unscrewing screw SE (e.g. screwdriver type Philips No. 2).
5. Carefully remove the electronics unit of the converter housing (see the remark below).
6. Check if the voltage setting (only applicable for AC power supplies) and power fuse rating are correct on the new electronics unit. If necessary, change the voltage setting or replace the power fuse (see Sect. 5.3 and 5.4 of this manual).
7. Carefully insert the electronics unit (keep cables aside, see remark below). Then mount the unit completely into the housing and fix the screws. First the two screws D, then screw SE and reconnect the 2-pole field circuit connector B and the 3-pole electrode circuit connector C to the right counter-plugs on the electronics unit (see figure in Sect. 5.1).
8. Finally screw the display unit back on the frame of the electronics via the two screws A.
9. Screw the cover of the electronics compartment back into the housing.

Note the instructions of Sect. 5.1 ("After opening") during reassembling.

IMPORTANT !

Carefully keep the connecting cables of the field coil and electrode circuits to the side of the housing, while removing respectively inserting the electronics unit into the signal converter housing. This is to prevent damaging of the connecting cables!

IFC 090-EEEx electronics unit (115/230 Vac version)

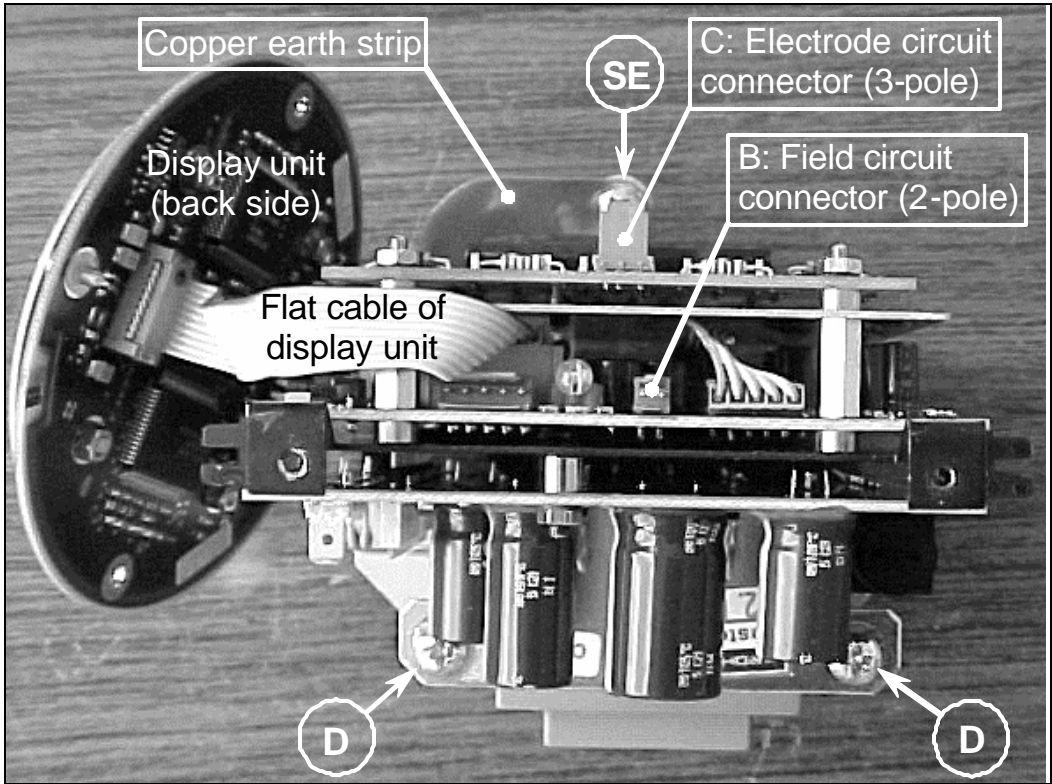

5.3 Replacement of power fuse(s)

The power fuse(s) of the different IFC 090...-EEx electronics units (regular or MODIS) have a different rating and are located on slightly different locations on the power supply printed circuit board. Only the power fuse on the 100...230 Vac power supply version of the regular IFC 090-EEx electronics unit can be reached without removing the complete unit out of the housing (only the display unit has to be unscrewed).

Regular IFC 090-EEx with 24 Vac/dc power supply

Note:	Before commencing work, read the instructions in Sect. 5.1 ("Before opening"). Then continue as follows:
--------------	--

1. Remove the cover of the electronics compartment.
2. Unscrew the two screws marked with A of the display unit and turn it carefully aside.
3. Disconnect the 2-pole field circuit connector (item B) as well as the 3-pole electrode circuit connector (item C). See figure in Sect.5.1 and 5.2.
4. Unscrew the two mounting screws D of the electronics unit and screw SE, which fixes the copper ground strip to the integrated aluminum dividing wall at the back of the electronics compartment. Use a screwdriver with a long shaft (≥ 200 mm) like type Philips No. 2 for screw SE. Then take out the electronics unit, but be careful with the connecting cables, so that they do not get damaged.
5. The defective power fuse(s) F1 and/or F2 (see following figure) can be replaced now. The 24 Vac/dc power supply uses two sub-miniature fuses type TR 5 that are rated T1.25 A in accordance with IEC 127-3 publication (part No. 5.09080.00.00).
6. Reassemble in reverse order (points 3 through 1).

Note:	Read the instructions of Sect. 5.1 ("After opening") during reassembling.
--------------	---

IFC 090-EEx electronics unit with 24 Vac/dc power supply

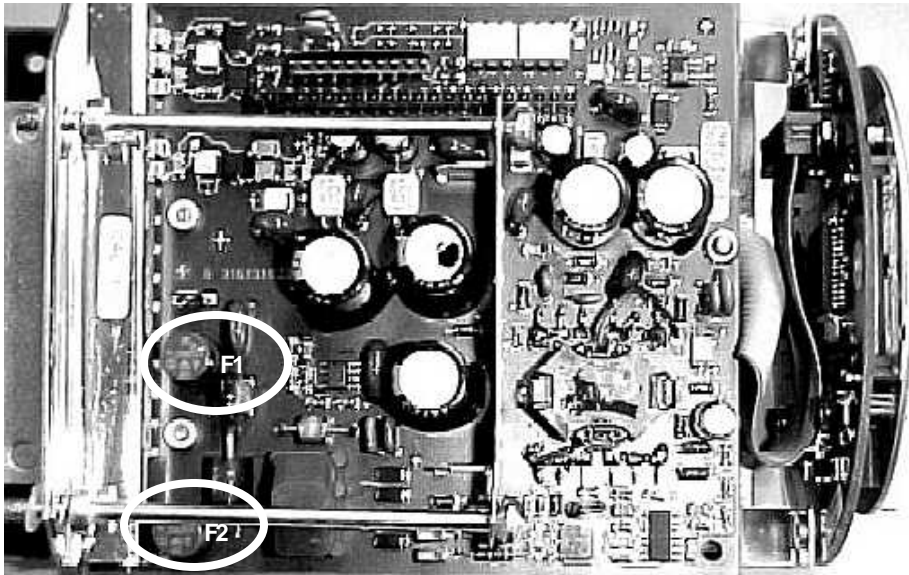

F1 and F2 fuses of power supply

Regular IFC 090-EEx with 100...230 Vac power supply

Note: Before commencing work, read the instructions in Sect. 5.1 ("Before opening"). Then continue as follows:

1. Remove the cover of the electronics compartment
2. Unscrew the two screws A of the display unit and turn the display unit carefully aside.
3. The fuse-holder, in which the power fuse in accordance with IEC 127-2 size $\varnothing 5 \times 20$ mm is mounted, is now accessible to replace the defect power fuse F1 by a new fuse with the same rating. The rating depends on the voltage setting of the power supply unit. The power supply of 100/115 Vac requires a fuse of T200mA (part No. 5.05678.00.00) and the 200/230 Vac requires a fuse of T125 mA (part No. 5.06627.00.00).

The fuse rating is also shown by the yellow sticker that is glued on the mains transformer, which can only be seen after the regular IFC 090-EEx electronics unit is completely removed from the flameproof signal converter housing. See figure on the next page.

NOTE: In case of any doubt about the fuse rating or the voltage setting of the unit, remove the complete unit from the housing as described in Sect. 5.2 and check in the following figure depicted items. Change when needed !

4. Reassemble the unit in reverse order (points 2 and 1).

Note Read the instructions of Sect. 5.1 ("After opening") during reassembling.

Power supply version 115/230 Vac

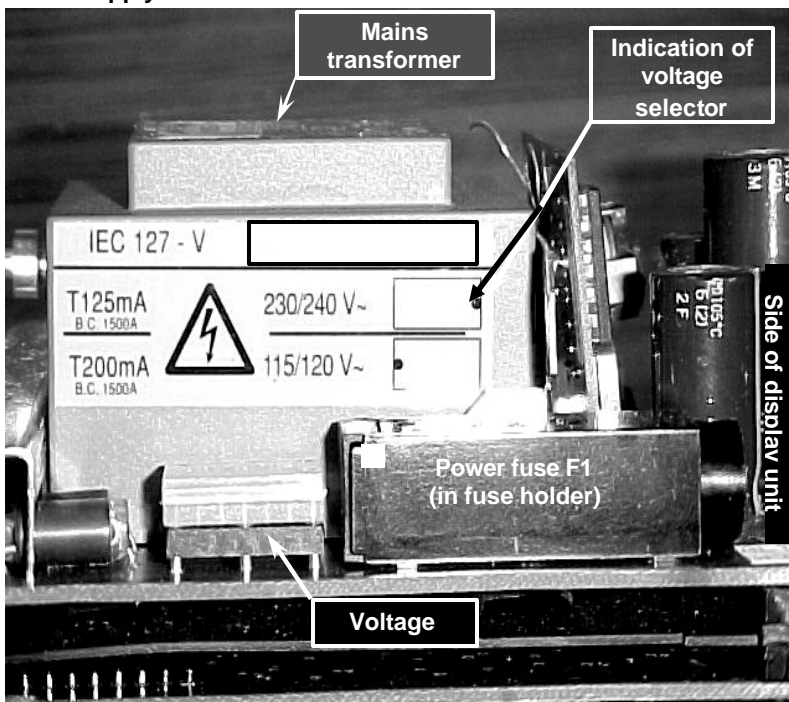

MODIS version IFC 090i-EEx

Note: Before commencing work, read the instructions in Sect. 5.1 ("Before opening"). Then continue as follows:

1. Remove the cover of the electronics compartment
2. Unscrew the two screws A of the display unit and turn it carefully aside.
3. Disconnect the 2-pole field circuit connector (item B) and the 3-pole electrode circuit connector (item C). See figures in Sect. 5.1 and 5.2 for details.
4. Unscrew the two screws D and screw SE by a screwdriver with a long shaft (200 mm). Take out the electronics unit, but do not damage the connecting cables. See the note **IMPORTANT**.
5. The defective power fuse (see following figure) can be replaced now. Use a fuse rated at T1.25H250V (part No. 5.06232.00.00) for the 24 Vac/dc power supply and a fuse rated at T1.6H250V (Part No. 5.07823.00.00) for the 100...230 Vac power supply. Note that the locations are slightly different (the 24 Vac/dc supply version is shown).
6. Reassemble in reverse order (points 4 through 1).

Note: Read the instructions of Sect. 5.1 ("After opening") during reassembling

Important! Carefully keep the connecting cables of the field coil and electrode circuits to the side of the housing, while removing or inserting the electronics unit into the signal converter housing. This is to prevent damaging of the connecting cables!

IFC 090i-EEx electronics unit (24 Vac/dc version is shown)

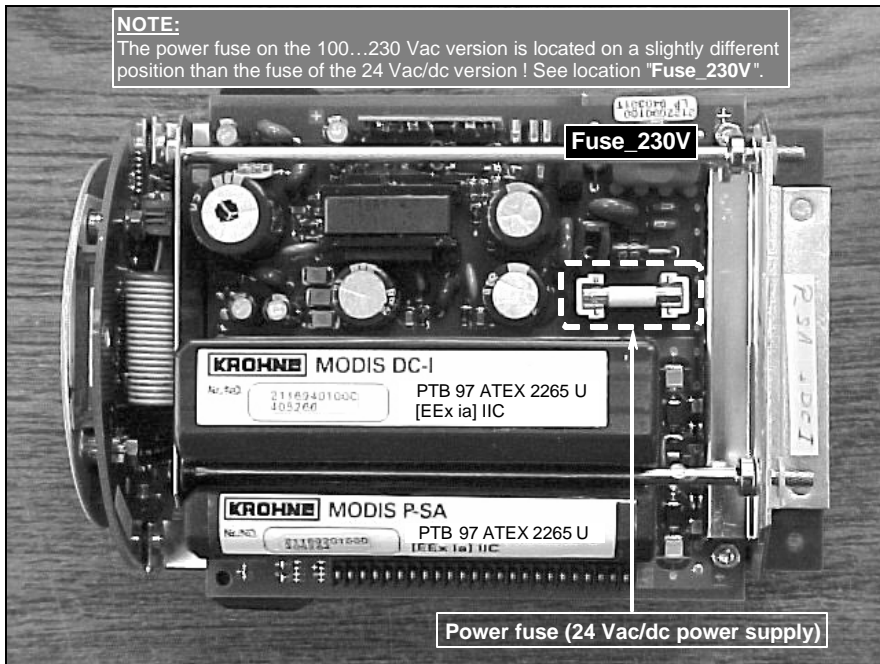

5.4 Changing power supply voltage

This only applies to the regular IFC 090-EEEx electronics unit with 100-230 Vac power supply.

Note:	Before commencing work, read the instructions in Sect. 5.1 ("Before opening"). Then continue as follows
--------------	---

:

1. Remove the cover of the electronics compartment.
2. Unscrew the two screws A of the display unit and turn the display unit carefully aside.
3. Unscrew the two mounting screws D of the electronics unit and screw SE, which fixes the copper ground strip at the back of the housing. A screwdriver with a long shaft (200 mm) can best be used to unscrew SE (e.g. screwdriver type Philips No. 2).
4. Disconnect the 2-pole and 3-pole connectors and carefully remove the electronics unit.
5. The voltage setting of the power pole supply can be changed by turning the dummy dual-in-line block (i.e. voltage selector, see last figure in Sect. 5.3) over 180° in its socket. The position of the notch on the dummy dual-in-line block indicates the voltage setting. Also see the sticker that is glued on the mains transformer.
6. Reassemble in reverse order (points 4 through 1).
7. Screw the cover of the electronics compartment back into the housing.

Note:	Note the instructions of Sect. 5.1 ("After opening") during reassembling.
--------------	---

IMPORTANT!	Carefully keep the connecting cables of the field coil and electrode circuits to the side of the housing, while inserting the electronics unit into respectively removing it from the signal converter housing. This is to prevent damaging of the connecting cables!
-------------------	---

6 Ordering information

In case of questions about spare or replacing parts contact your local Krohne representative. The part numbers of the several parts are listed in the sections below.

6.1 Regular IFC 090-EEEx electronics unit

The table below shows the regular (non-MODIS) IFC 090-EEEx versions available with the possible power supply units and the accompanying power fuse(s).

IFC 090-EEEx electronics unit		Power fuse(s)			
Power supply	Part No.	Symbol	Type	Rating	Part No.
230/240 Vac	2.10664.10.00	F1	G-fuse Ø5x20	125 mA T	5.06627.00.00
115/120 Vac		F1		200 mA T	5.05678.00.00
200 Vac	2.10664.13.00	F1	1500A @ 250V	125 mA T	5.06627.00.00
100 Vac		F1		200 mA T	5.05678.00.00
24 Vac/dc	2.10665.10.00	F1 + F2	TR5, 35A @ 250V	1.25 A T	5.09080.00.00

6.2 MODIS version IFC 090i-EEEx electronics unit

The following table gives a summary of the IFC 090i-EEEx electronics units available (MODIS version) and the matching part number. These IFC 090i-EEEx electronics units are either provided with a 24 Vac/dc power supply or a 100...230 Vac power supply.

Version	MODIS modules		Part number	
	Position A	Position B	24 Vac/dc power supply	100...230 Vac power supply
Ex-i1	P-SA	FA-ST	2.11582.01.00	2.12253.01.00
Ex-i2	P-SA	F-PA	2.11582.03.00	2.12253.02.00
Ex-i3	P-SA	DC-I	2.11582.02.00	not available
Ex-i4	FA-ST	F-PA	2.11582.05.00	2.12253.03.00
Ex-i5	FA-ST	DC-I	2.11582.06.00	not available
Ex-i6	FA-ST	FA-ST	2.11582.07.00	2.12253.04.00
Ex-i7	P-SA	F-FF	2.11582.08.00	2.12253.05.00
Ex-i8	FA-ST	F-FF	2.11582.09.00	2.12253.06.00

The following table below lists the accompanying power fuse.

Power supply version	Power fuse for IFC 090i-EEEx electronics units		
	Type	Rating	Part number
24 Vac/dc	G-fuse Ø5x20 1500A @ 250V	1.25 A T (T1.25H250V)	5.06232.00.00
100...230 Vac	G-fuse Ø5x20 1500A @ 250V	1.6 A T (T1.6H250V)	5.07823.00.00

Notes:	All G-fuses listed comply with IEC 127-2. They are Ø5 x 20 mm in size and blow at 1500 A at 250 V .
---------------	---

Fuse type TR5 is sub-miniature and blows at 35 A at 250 V. It, too, complies with IEC 127-3. The regular IFC 090-EEEx electronics unit with 24 Vac/dc power supply contains two of these fuses in the primary circuits, labelled as F1 and F2.

7 Declarations of conformity

7.1 Declaration of conformity of ALTOFLUX IFM 4080 K ... EEx



Altometer

EC - Declaration of Conformity

We

Krohne Altometer
Kerkeplaat 12
3313 LC Dordrecht
The Netherlands

declare under our sole responsibility that the products

compact magnetic inductive flowmeter types

IFM 4080 K - EEx and
IFM 4080 K / i- EEx
IFM 4042 K- EEx

fulfill the requirements of following EC directives:

- ATEX Directive 94/9/EC
- EMC Directive 89/336/EC

The IFM 4080 K-EEx, IFM 4080 K / i-EEx and IFM 4042 K-EEx flowmeters are designed and manufactured conform following harmonized standards:

- EN 50 014 : 1997
- EN 50 018 : 2000
- EN 50 019 : 2000
- EN 50 020 : 1994
- EN 50 281-1-1 : 1998

- EN 50 081-1
- EN 50 082-2
- EN 61 010-1

The IFM 4080 K-EEx, IFM 4080 K / i-EEx and IFM 4042 K-EEx flowmeters are examined and type-approved under EC-type examination certificate KEMA 01 ATEX 2200 X. Our quality system is assessed by KEMA registered Quality b.v.

Dordrecht, 26-03-2002

L. IJmker
(General manager)



7.2 Declaration of conformity of PROFIFLUX IFM 5080 K ... EEx



EC - Declaration of Conformity

We

Krohne Altometer
Kerkeplaat 12
3313 LC Dordrecht
The Netherlands

declare under our sole responsibility that the products

compact magnetic inductive flowmeters types

**IFM 5080 K - EEx and
IFM 5080 K / i- EEx**

fulfill the requirements of following EC directives:

- ATEX Directive 94/9/EC
- EMC Directive 89/336/EC

The IFM 5080 K-EEx and IFM 5080 K / i-EEx flowmeters are designed and manufactured conform following harmonized standards:

- EN 50 014 : 1997
- EN 50 018 : 2000
- EN 50 019 : 2000
- EN 50 020 : 1994
- EN 50 028 : 1987
- EN 50 281-1-1 : 1998

- EN 50 081-1
- EN 50 082-2
- EN 61 010-1

The IFM 5080 K-EEx and IFM 5080 K / i-EEx are examined and type-approved under EC-type examination certificate KEMA 01 ATEX 2262 X. Our quality system is assessed by KEMA registered Quality b.v.

Dordrecht, 29-04-2002

L. IJmker
(General manager)

7.3 Declaration of conformity of VARIFLUX IFM 6080 K ... EEx



Altometer

EC - Declaration of Conformity

We

Krohne Altometer
Kerkeplaat 12
3313 LC Dordrecht
The Netherlands

declare under our sole responsibility that the products

compact magnetic inductive flowmeters types

**IFM 6080 K - EEx and
IFM 6080 K / i- EEx**

fulfill the requirements of following EC directives:

- ATEX Directive 94/9/EC
- EMC Directive 89/336/EC

The IFM 6080 K-EEx and IFM 6080 K / i-EEx flowmeters are designed and manufactured conform following harmonized standards:

- EN 50 014 : 1997
- EN 50 018 : 2000
- EN 50 019 : 2000
- EN 50 020 : 1994
- EN 50 028 : 1987
- EN 50 281-1-1 : 1998

- EN 50 081-1
- EN 50 082-2
- EN 61 010-1

The IFM 6080 K-EEx and IFM 6080 K / i-EEx flowmeters are examined and type approved under EC-type examination certificate KEMA 02 ATEX 2021 X. Our quality system is assessed by KEMA registered Quality b.v.

Dordrecht, 29-04-2002

L. Ijmker
(General manager)

8 EC-type examination Certificates

8.1 IFM 4080 K ... EEx Certificate



(1) **EC-TYPE EXAMINATION CERTIFICATE**

(2) Equipment or protective system intended for use in potentially explosive atmospheres – Directive 94/9/EC

(3) EC-Type Examination Certificate Number: **KEMA 01ATEX2200 X**

(4) Equipment or protective system: **Compact Magnetic Inductive Flowmeter, types IFM 4080 K/...-EEx, IFM 4042 K-EEx, MGM 4090 K/...-EEx and MGM 4042 K-EEx**

(5) Manufacturer: **Krohne Altometer**

(6) Address: **Kerkepleaat 12, 3313 LC Dordrecht, The Netherlands**

(7) This equipment or protective system and any acceptable variation thereto is specified in the schedule to this certificate and the documents therein referred to.

(8) KEMA Quality B.V., notified body number 0344 in accordance with Article 9 of the Council Directive 94/9/EC of 23 March 1994, certifies that this equipment or protective system has been found to comply with the Essential Health and Safety Requirements relating to the design and construction of equipment and protective systems intended for use in potentially explosive atmospheres given in Annex II to the Directive.

The examination and test results are recorded in confidential report no. 2011054.

(9) Compliance with the Essential Health and Safety Requirements has been assured by compliance with:

EN 50014 : 1997
EN 50020 : 1994

EN 50018 : 2000
EN 50281-1-1 : 1998

EN 50019 : 2000

(10) If the sign "X" is placed after the certificate number, it indicates that the equipment or protective system is subject to special conditions for safe use specified in the schedule to this certificate.

(11) This EC-Type Examination Certificate relates only to the design, examination and tests of the specified equipment or protective system in accordance with the Directive 94/9/EC. Further requirements of the Directive apply to the manufacturing process and supply of this equipment or protective system. These are not covered by this certificate.

(12) The marking of the equipment or protective system shall include the following:



II 2 GD EEx d [Ib] IIC T6...T3 or EEx de [Ib] IIC T6...T3 or
EEx d [Ia] [Ib] IIC T6...T3 or EEx de [Ia] [Ib] IIC T6...T3
T 85...180 °C

Amhem, 28 March 2002

KEMA Quality B.V.

T. Pijpers
Certification Manager

* This Certificate may only be reproduced in its entirety and without any change.

KEMA Quality B.V.
Utrechtseweg 310, 3812 AR Amhem, The Netherlands
P.O. Box 5185, 6802 ED Amhem, The Netherlands
Telephone +31 26 3 56 20 06, Telefax +31 26 3 62 58 00

ACCREDITED BY THE
DUTCH COUNCIL FOR
ACCREDITATION



Page 1/6

(13)

SCHEDULE

(14)

to EC-Type Examination Certificate KEMA 01ATEX2200 X

(15)

Description

The Compact Magnetic Inductive Flowmeter, types IFM 4080 K/...-EEx, IFM 4042 K-EEx, MGM 4090 K/...-EEx and MGM 4042 K-EEx is used for measuring, counting and displaying the linear flow of an electrical conductive liquid.

The flowmeter consists of a signal converter housing in type of explosion protection flameproof enclosure "d" with a terminal compartment in type of explosion protection flameproof enclosure "d" or increased safety "e". The integral primary heads are in type of explosion protection flameproof enclosure "d" (sizes DN25 - DN150) or increased safety "e" (DN200 - DN3000) and are provided with measuring electrodes in type of explosion protection intrinsic safety EEx ib IIC.

Ambient temperature range -20 °C ... +60 °C (for flowmeter with electronics unit type IFC 090).

Ambient temperature range -40 °C ... +60 °C (for flowmeter with electronics unit types IFC 040 and IFC 090).

The maximum surface temperature T 85...180 °C is based on a maximum ambient temperature of 60 °C.

Electrical data

IFM4080 K/...-EEx / MGM 4090 K/...-EEx with IFC 090-EEx electronics

Power supply 100/200 Vac, 115/230 Vac -15/+10 %, 10 VA
24 Vdc -25/+30 %, 24 Vac -15/+10 %, 8 W
 $U_m = 253$ V

Signal I/O's ≤ 36 Vdc

IFM4080 K/...-EEx / MGM 4090 K/...-EEx with IFC 090-EEx electronics

Power supply 100...230 Vac -15/+10 %, 15 VA
24 Vdc -25/+30 %, 24 Vac -15/+10 %, 10 W
 $U_m = 253$ V

Signal circuit

Modules P-SA and FA-ST In type of explosion protection intrinsic safety EEx ia IIC, only for connection to a certified intrinsically safe circuit in type of explosion protection intrinsic safety

EEx ia IIC or EEx ia IIB or

EEx ib IIC or EEx ib IIB,

with the following maximum values:

U_i	=	30	V
I_i	=	250	mA
P_i	=	1,0	W

The effective internal capacitance $C_i = 5$ nF,
the effective internal inductance L_i is negligibly small.

(13)

SCHEDULE

(14)

to EC-Type Examination Certificate KEMA 01ATEX2200 X

Electrical data (continued)

Signal circuit

Modules F-PA and F-FF in type of explosion protection intrinsic safety EEx ia IIC, only for connection to a certified intrinsically safe circuit (for instance a Supply of the FISCO Model in accordance with document CLC/SC31-3(SEC)155 of Dec. 2000) in type of explosion protection intrinsic safety
EEx ia IIC or EEx ia IIB or
EEx ib IIC or EEx ib IIB,
with the following maximum values:

U_i	=	30	V
I_i	=	300	mA
P_i	=	4,2	W

The effective internal capacitance $C_i = 5$ nF,
the effective internal inductance L_i is negligibly small.

Signal/supply circuit

Module DC-I in type of explosion protection intrinsic safety EEx ia IIC,
(24 Vdc/dc version only) with the following maximum values:

U_o	=	23,5	V
I_o	=	98	mA
P_o	=	0,6	W

Maximum allowed external capacitance $C_o = 127$ nF,
maximum allowed external inductance $L_o = 4$ mH.

Only for connection to certified intrinsically safe circuits
in type of explosion protection EEx ia IIC or EEx ia IIB or
EEx ib IIC or EEx ib IIB without supply (passive).

The applicable type of explosion protection of the aforementioned intrinsically safe circuits EEx ia IIC is determined by the type of protection of the intrinsically safe circuit which is connected to it, respectively EEx ia IIB or EEx ib IIC or EEx ib IIB.

The aforementioned intrinsically safe circuits shall, from the safety point of view, be considered to be connected to ground.

IFM 4042 K-EEEx / MGM 4042 K-EEEx with IFC 040-EEEx electronics

The signal/supply circuits may all be connected either intrinsically safe or non-intrinsically safe. A combination of intrinsic and non-intrinsic safe connections however is not allowed.

e) Connection to a non-intrinsically safe circuit

Signal/supply circuit 1 14 - 36 Vdc, 4 - 20 mA

Signal/supply circuit 2 14 - 36 Vdc, 22 mA

Signal/supply circuit 3 max. 35 Vdc, 100 mA

(13)

SCHEDULE

(14)

to EC-Type Examination Certificate KEMA 01ATEX2200 X**Electrical data (continued)**

b) Connection to an intrinsically safe circuit

Signal/supply circuits 1 and 2... In type of explosion protection intrinsic safety EEx ib IIC with the following maximum values (each circuit):

U_i	=	30	V
I_i	=	100	mA
P_i	=	1,0	W

The effective internal capacitance $C_i = 20$ nF,
the effective internal inductance L_i is negligibly small.

Signal/supply circuit 3 In type of explosion protection intrinsic safety EEx ib IIC with the following maximum values:

U_i	=	30	V
I_i	=	100	mA
P_i	=	1,0	W

The effective internal capacitance C_i is negligibly small,
the effective internal inductance L_i is negligibly small.

The applicable type of explosion protection of the aforementioned intrinsically safe circuits EEx ib IIC is determined by the type of protection of the intrinsically safe circuit which is connected to it, respectively EEx ib IIB.

The aforementioned intrinsically safe circuits are safely galvanically separated from the non-intrinsically safe circuits up to a peak value $U_M = 60$ V.**Installation instructions**For use in potentially explosive atmospheres of flammable gases, fluids or vapours:
The cable entry device shall be in type of protection flameproof enclosure "d" for the terminal compartment in type of protection flameproof enclosure "d" or increased safety "e" for the terminal compartment in type of protection increased safety "e", suitable for the conditions of use and correctly installed.For use in the presence of combustible dust:
The cable entry device shall be in type of equipment Category II 2 D, suitable for the conditions of use and correctly installed.

Unused openings shall be closed with suitable certified closing elements.

With the use of conduit, a suitable certified sealing device such as a stopping box with setting compound shall be provided immediately at the entrance to the flameproof enclosure.

Routine tests

- Each welded primary head of size DN25 - DN150 must be submitted to the routine overpressure test according to EN 50018, Clause 16 at a test pressure of 14 bar during one minute.

(13)

SCHEDULE

(14)

to EC-Type Examination Certificate KEMA 01ATEX2200 X

Routine tests (continued)

- Routine tests according to EN 50018, Clause 16 are not required for the electronics enclosure since the type test has been made at a static pressure of four times the reference pressure.

Each primary head of size DN200 - DN3000 shall withstand a test voltage according to EN 50018, Clause 6.1, of 500 V during one minute without breakdown between the field coils circuit and the enclosure and a test voltage of 1500 Vrms during one minute without breakdown between the field coils circuit and the intrinsically safe sensor circuit.

(16) **Report**

KEMA No. 2011054.

(17) **Special conditions for safe use**

The relation between temperature class, maximum surface temperature, maximum process temperature and ambient temperature is shown in the following tables:

a) Meter size DN25 - DN150

Temperature class	Max. surface temperature	Max. process temperature		
		Ta ≤ 40 °C	Ta ≤ 50 °C	Ta ≤ 60 °C
T6	T 85 °C	70 °C	70 °C	70 °C
T5	T 100 °C	85 °C	85 °C	85 °C
T4	T 135 °C	120 °C	120 °C	115 °C
T3	T 180 °C	180 °C	180 °C	115 °C

For Ta > 50 °C and a process temperature ≤ 115 °C, heat resistant cables with a continuous operating temperature of at least 120 °C must be used.

b) Meter size DN200 - DN3000

Temperature class	Max. surface temperature	Max. process temperature		
		Ta ≤ 40 °C	Ta ≤ 50 °C	Ta ≤ 60 °C
T6	T 85 °C	75 °C	70 °C	70 °C
T5	T 100 °C	95 °C	90 °C	75 °C
T4	T 135 °C	130 °C	115 °C	75 °C
T3	T 180 °C	150 °C	115 °C	75 °C

(18) **Essential Health and Safety Requirements**

Covered by the standards listed at (9).

(13)

SCHEDULE

(14)

to EC-Type Examination Certificate KEMA 01ATEX2200 X

(19) **Test documentation**

- | | | |
|---------------------------|--|--------------|
| 1. Component Certificate | KEMA No. Ex-99.E.8128 U
KEMA No. Ex-01.E.2036 U
Certificate of Conformity KEMA No. Ex-97.D.2886 X
PTB No. Ex-90.C.2003 X
PTB No. Ex-95.D.2209
EC-Type Examination Certificate KEMA 01ATEX2263 X
PTB 98 ATEX 2012 U
PTB 00 ATEX 2213 U | <u>dated</u> |
| 2. Description (22 pages) | | 04.03.2002 |
| 3. Drawings index sheet | | 04.03.2002 |

8.2 IFM 5080 K ... EEx Certificate



(1) EC-TYPE EXAMINATION CERTIFICATE

(2) Equipment or protective system intended for use in potentially explosive atmospheres – Directive 94/9/EC

(3) EC-Type Examination Certificate Number: **KEMA 01ATEX2262 X**

(4) Equipment or protective system: **Compact Magnetic Inductive Flowmeter, types IFM 5080 K-EEEx, IFM 5080 KI-EEEx, MGM 5090 K-EEEx and MGM 5090 KI-EEEx**

(5) Manufacturer: **Krohne Altimeter**

(6) Address: **Karkeplaat 12, 3313 LC Dordrecht, The Netherlands**

(7) This equipment or protective system and any acceptable variation thereto is specified in the schedule to this certificate and the documents therein referred to.

(8) KEMA Quality B.V., notified body number 0344 in accordance with Article 9 of the Council Directive 94/9/EC of 23 March 1994, certifies that this equipment or protective system has been found to comply with the Essential Health and Safety Requirements relating to the design and construction of equipment and protective systems intended for use in potentially explosive atmospheres given in Annex II to the Directive.

The examination and test results are recorded in confidential report no. 2016673.

(9) Compliance with the Essential Health and Safety Requirements has been assured by compliance with:

EN 50014 : 1997
EN 50020 : 1994

EN 50018 : 2000
EN 50028 : 1987

EN 50019 : 2000
EN 50281-1-1 : 1998

(10) If the sign "X" is placed after the certificate number, it indicates that the equipment or protective system is subject to special conditions for safe use specified in the schedule to this certificate.

(11) This EC-Type Examination Certificate relates only to the design, examination and tests of the specified equipment or protective system in accordance with the Directive 94/9/EC. Further requirements of the Directive apply to the manufacturing process and supply of this equipment or protective system. These are not covered by this certificate.

(12) The marking of the equipment or protective system shall include the following:



**II 2 GD EEx dme [Ib] IIC T6...T3 or EEx dme [Ib] [Ia] IIC T6...T3
T 80 ... 165 °C**

Amhem, 1 February 2002,
KEMA Quality B.V.

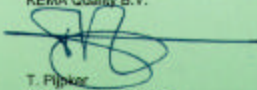
T. Pijper
Certification Manager

* The Certificate may only be reproduced in its entirety and without any change

KEMA Quality B.V.
Utrechtseweg 310, 6812 AR Amhem, The Netherlands
P.O. Box 5185, 6802 ED Amhem, The Netherlands
Telephone +31 26 3 56 20 03, Telefax +31 26 3 52 58 00

ACCREDITED BY THE
DUTCH COUNCIL FOR
ACCREDITATION



Page 1/4

(13)

SCHEDULE

(14)

to EC-Type Examination Certificate KEMA 01ATEX2262 X

(15) **Description**

The Compact Magnetic Inductive Flowmeter, types IFM 5080 K-EEEx, IFM 5080Ki-EEEx, MGM 5090 K-EEEx and MGM 5090 Ki-EEEx is used for measuring, counting and displaying the linear flow of an electrical conductive liquid.

The flowmeter consists of a signal converter housing in type of explosion protection flameproof enclosure "d" with a terminal compartment in type of explosion protection flameproof enclosure "d" or increased safety "e". The integral primary heads sizes DN2,5 to DN100 are in type of explosion protection encapsulation "m" and are provided with measuring electrodes in type of explosion protection intrinsic safety EEx ib IIC.

Ambient temperature range -20 °C ... +60 °C.

Electrical data

IFM5080 K-EEEx / MGM 5090 K-EEEx with IFC090-EEEx electronics

Power supply 100/200 Vac, 115/230 Vac -15/+10 %, 10 VA
24 Vdc -25/+30 %, 24 Vac -15/+10 %, 8 W
 $U_m = 253 \text{ V}$

Signal I/O's $\leq 36 \text{ Vdc}$

IFM5080 Ki-EEEx / MGM 5090 Ki-EEEx with IFC090i-EEEx electronics

Power supply 100... 230 Vac -15/+10 %, 15 VA
24 Vdc -25/+30 %, 24 Vac -15/+10 %, 10 W
 $U_m = 253 \text{ V}$

Signal circuit

Modules P-SA and FA-ST in type of explosion protection intrinsic safety EEx ia IIC, only for connection to a certified intrinsically safe circuit in type of explosion protection intrinsic safety EEx ia IIC or EEx ia IIB or EEx ib IIC or EEx ib IIB, with the following maximum values:

$$\begin{aligned} U_i &= 30 \text{ V} \\ I_i &= 250 \text{ mA} \\ P_i &= 1,0 \text{ W} \end{aligned}$$

The effective internal capacitance $C_i = 5 \text{ nF}$,
the effective internal inductance L_i is negligibly small.

(13)

SCHEDULE

(14)

to EC-Type Examination Certificate KEMA 01ATEX2262 X

Electrical data (continued)

Signal circuit

Modules F-PA and F-FF in type of explosion protection intrinsic safety EEx ia IIC, only for connection to a certified intrinsically safe circuit (for instance a Supply of the FISCO Model in accordance with document CLC/SC31-3(SEC)155 of Dec. 2000) in type of explosion protection intrinsic safety EEx ia IIC or EEx ia IIB or EEx ib IIC or EEx ib IIB, with the following maximum values:

U_i	=	30	V
I_i	=	300	mA
P_i	=	4,2	W

The effective internal capacitance $C_i = 5$ nF, the effective internal inductance L_i is negligibly small.

Signal/supply circuit

Module DC-1 in type of explosion protection intrinsic safety EEx ia IIC, with the following maximum values:
(24 Vac/dc version only)

U_o	=	23,5	V
I_o	=	98	mA
P_o	=	0,6	W

Maximum allowed external capacitance $C_o = 127$ nF, maximum allowed external inductance $L_o = 4$ mH.

Only for connection to certified intrinsically safe circuits in type of explosion protection EEx ia IIC or EEx ia IIB or EEx ib IIC or EEx ib IIB without supply (passive).

The applicable type of explosion protection of the aforementioned intrinsically safe circuits EEx ia IIC is determined by the type of protection of the intrinsically safe circuit which is connected to it, respectively EEx ia IIB or EEx ib IIC or EEx ib IIB.

The aforementioned intrinsically safe circuits shall, from the safety point of view, be considered to be connected to ground.

Installation instructions

For use in potentially explosive atmospheres of flammable gases, fluids or vapours:
The cable entry device shall be in type of protection flameproof enclosure "d" for the terminal compartment in type of protection flameproof enclosure "d" or increased safety "e" for the terminal compartment in type of protection increased safety "e", suitable for the conditions of use and correctly installed.

For use in the presence of combustible dust:
The cable entry device shall be in type of equipment Category II 2 D, suitable for the conditions of use and correctly installed.

Unused openings shall be closed with suitable certified closing elements.

(13)

SCHEDULE

(14)

to EC-Type Examination Certificate KEMA 01ATEX2262 X

Installation instructions (continued)

With the use of conduit, a suitable certified sealing device such as a stopping box with setting compound shall be provided immediately at the entrance to the flameproof enclosure.

Routine tests

- Each primary head shall withstand a test voltage according to EN 50028, Clause 7.2. of 1500 V during one minute without breakdown between the field coils circuit and the enclosure and between the field coils circuit and the intrinsically safe sensor circuit.

- Routine tests according to EN 50018, Clause 16 are not required for the electronics enclosure since the type test has been made at a static pressure of four times the reference pressure.

(16) **Report**

KEMA No. 2016673.

(17) **Special conditions for safe use**

The relation between temperature class, max. surface temperature, max. process temperature and ambient temperature is shown in following table:

Temperature class	Max. surface temperature	Max. process temperature		
		Ta ≤ 40 °C	Ta ≤ 50 °C	Ta ≤ 60 °C
T6	T 80 °C	60 °C	55 °C	Not allowed
T5	T 95 °C	75 °C	75 °C	70 °C
T4	T 130 °C	115 °C	115 °C	75 °C
T3	T 165 °C	155 °C	135 °C	75 °C

(18) **Essential Health and Safety Requirements**

Covered by the standards listed at (9).

(19) **Test documentation**

- Component Certificate KEMA No. Ex-99.E.8128 U
KEMA No. Ex-01.E.2036 U
Certificate of Conformity KEMA No. Ex-92.C.7162
EC-Type Examination Certificate PTB 98 ATEX 2012 U
dated
- Description (21 pages) 05.04.2001, 03.01.2002, 21.01.2002,
22.01.2002 and 23.01.2002
- Drawings index sheet 22.01.2002

8.3 IFM 6080 K ... EEx Certificate



(1) **EC-TYPE EXAMINATION CERTIFICATE**

(2) Equipment or protective system intended for use in potentially explosive atmospheres – Directive 94/9/EC

(3) EC-Type Examination Certificate Number: **KEMA 02ATEX2021 X**

(4) Equipment or protective system: **Compact Magnetic Inductive Flowmeter, types IFM 6080 K-EEEx, IFM 6080 KI-EEEx, MGM 6090 K-EEEx and MGM 6090 KI-EEEx**

(5) Manufacturer: **Krohne Altimeter**

(6) Address: **Kerkeplaat 12, 3313 LC Dordrecht, The Netherlands**

(7) This equipment or protective system and any acceptable variation thereto is specified in the schedule to this certificate and the documents therein referred to.

(8) KEMA Quality B.V., notified body number 0344 in accordance with Article 9 of the Council Directive 94/9/EC of 23 March 1994, certifies that this equipment or protective system has been found to comply with the Essential Health and Safety Requirements relating to the design and construction of equipment and protective systems intended for use in potentially explosive atmospheres given in Annex II to the Directive.

The examination and test results are recorded in confidential report no. 2017354.

(9) Compliance with the Essential Health and Safety Requirements has been assured by compliance with:

EN 50014 : 1997
EN 50020 : 1994

EN 50018 : 2000
EN 50028 : 1987

EN 50019 : 2000
EN 50281-1-1 : 1998

(10) If the sign "X" is placed after the certificate number, it indicates that the equipment or protective system is subject to special conditions for safe use specified in the schedule to this certificate.

(11) This EC-Type Examination Certificate relates only to the design, examination and tests of the specified equipment or protective system in accordance with the Directive 94/9/EC. Further requirements of the Directive apply to the manufacturing process and supply of this equipment or protective system. These are not covered by this certificate.

(12) The marking of the equipment or protective system shall include the following:



II 2 GD

EEx d [ib] IIC T6...T3 or EEx de [ib] IIC T6...T3 or
EEx dme [ib] IIC T6...T3 or EEx d [ib] [ia] IIC T6...T3 or
EEx de IIC [ib] [ia] IIC T6...T3 or EEx dme IIC [ib] [ia] IIC T6...T3
T 80 ... 190 °C

Anhem, 7 February 2002,
KEMA Quality B.V.

T. Pijpker
Certification Manager

* This Certificate may only be reproduced in its entirety and without any change

KEMA Quality B.V.
Utrechtseweg 310, 6812 AR Anhem, The Netherlands
P.O. Box 5185, 6802 ED Anhem, The Netherlands
Telephone +31 26 3 56 20 06, Telefax +31 26 3 52 56 00

ACCREDITED BY THE
DUTCH COUNCIL FOR
ACCREDITATION



(13)

SCHEDULE

(14)

to EC-Type Examination Certificate KEMA 02ATEX2021 X

(15) **Description**

The Compact Magnetic Inductive Flowmeter, types IFM 6080 K-EEEx, IFM 6080 K/I-EEEx, MGM 6090 K-EEEx and MGM 6090 K/I-EEEx is used for measuring, counting and displaying the linear flow of an electrical conductive liquid.

The flowmeter consists of a signal converter housing in type of explosion protection flameproof enclosure "d" with a terminal compartment in type of explosion protection flameproof enclosure "d" or increased safety "e". The integral primary heads are in type of explosion protection encapsulation "m" (sizes DN2,5 - DN15) or flameproof enclosure "d" (sizes DN25 - DN80) and are provided with measuring electrodes in type of explosion protection intrinsic safety EEx ia IIC.

Ambient temperature range -20 °C... +60 °C (for flowmeter with electronics unit type IFC 090).

Ambient temperature range -40 °C ... +60 °C (for flowmeter with electronics unit type IFC090).

Electrical data

IFM6080 K-EEEx / MGM 6090 K-EEEx with IFC090-EEEx electronics

Power supply 100/200 Vac, 115/230 Vac -15/+10 %, 10 VA
24 Vdc -25/+30 %, 24 Vac -15/+10 %, 8 W
 $U_n = 253 \text{ V}$

Signal I/O's $\leq 36 \text{ Vdc}$

IFM6080 K/I-EEEx / MGM 6090 K/I-EEEx with IFC090i-EEEx electronics

Power supply 100...230 Vac -15/+10 %, 15 VA
24 Vdc -25/+30 %, 24 Vac -15/+10 %, 10 W
 $U_n = 253 \text{ V}$

Signal circuit

Modules P-SA and FA-ST in type of explosion protection intrinsic safety EEx ia IIC, only for connection to a certified intrinsically safe circuit in type of explosion protection intrinsic safety

EEx ia IIC or EEx ia IIB or

EEx ib IIC or EEx ib IIB,

with the following maximum values:

U_i	=	30	V
I_i	=	250	mA
P_i	=	1,0	W

The effective internal capacitance $C_i = 5 \text{ nF}$,
the effective internal inductance L_i is negligibly small.

(13)

SCHEDULE

(14)

to EC-Type Examination Certificate KEMA 02ATEX2021 X

Electrical data (continued)

Signal circuit

Modules F-PA and F-FF in type of explosion protection intrinsic safety EEx ia IIC, only for connection to a certified intrinsically safe circuit (for instance a Supply of the FISCO Model in accordance with document CLC/SC31-3(SEC)155 of Dec. 2000) in type of explosion protection intrinsic safety
EEx ia IIC or EEx ia IIB or
EEx ib IIC or EEx ib IIB,
with the following maximum values:

$$\begin{aligned} U_i &= 30 \text{ V} \\ I_i &= 300 \text{ mA} \\ P_i &= 4,2 \text{ W} \end{aligned}$$

The effective internal capacitance $C_i = 5 \text{ nF}$,
the effective internal inductance L_i is negligibly small.

Signal/supply circuit

Module DC-1 in type of explosion protection intrinsic safety EEx ia IIC,
(24 Vac/dc version only) with the following maximum values:

$$\begin{aligned} U_o &= 23,5 \text{ V} \\ I_o &= 98 \text{ mA} \\ P_o &= 0,6 \text{ W} \end{aligned}$$

Maximum allowed external capacitance $C_o = 127 \text{ nF}$,
maximum allowed external inductance $L_o = 4 \text{ mH}$.

Only for connection to certified intrinsically safe circuits
in type of explosion protection EEx ia IIC or EEx ia IIB or
EEx ib IIC or EEx ib IIB without supply (passive).

The applicable type of explosion protection of the aforementioned intrinsically safe circuits EEx ia IIC is determined by the type of protection of the intrinsically safe circuit which is connected to it, respectively EEx ia IIB or EEx ib IIC or EEx ib IIB.

The aforementioned intrinsically safe circuits shall, from the safety point of view, be considered to be connected to ground.

Installation instructions

For use in potentially explosive atmospheres of flammable gases, fluids or vapours:
The cable entry device shall be in type of protection flameproof enclosure "d" for the terminal compartment in type of protection flameproof enclosure "d" or increased safety "e" for the terminal compartment in type of protection increased safety "e", suitable for the conditions of use and correctly installed.

For use in the presence of combustible dust:
The cable entry device shall be in type of equipment Category II 2 D, suitable for the conditions of use and correctly installed.

Unused openings shall be closed with suitable certified closing elements.

(13)

SCHEDULE

(14)

to EC-Type Examination Certificate KEMA 02ATEX2021 X

Installation instructions (continued)

With the use of conduit, a suitable certified sealing device such as a stopping box with setting compound shall be provided immediately at the entrance to the flameproof enclosure.

Routine tests

- Each welded primary head of size DN25 - DN80 shall be submitted to the routine overpressure test according to EN 50018, Clause 16, at a test pressure of 13.5 bar during one minute.

- Routine tests according to EN 50018, Clause 16 are not required for the electronics enclosure since the type test has been made at a static pressure of four times the reference pressure.

- Each primary head shall withstand a test voltage of 1500 V during one minute without breakdown between the field coils circuit and the intrinsically safe sensor circuit. Each primary head of size DN2,5 - DN15 shall additionally withstand a test voltage of 1500 V during one minute without breakdown between the field coils circuit and the enclosure.

(16) **Report**

KEMA No. 2017354.

(17) **Special conditions for safe use**

The relation between temperature class, max. surface temperature, max. process temperature and ambient temperature is shown in following table:

Temperature class	Max. surface temperature	Max. process temperature	
		Ta ≤ 50 °C	Ta ≤ 60 °C
T6	T 80 °C	70 °C	70 °C
T5	T 95 °C	85 °C	85 °C
T4	T 130 °C	120 °C	100 °C
T3	T 190 °C	180 °C	100 °C

(18) **Essential Health and Safety Requirements**

Covered by the standards listed at (9).

(19) **Test documentation**

- Component Certificate KEMA No. Ex-99.E.8128 U
KEMA No. Ex-01.E.2036 U
Certificate of Conformity KEMA No. Ex-96.D.1850 X
EC-Type Examination Certificate PTB 98 ATEX 2012 U

(13)

SCHEDULE

(14)

to EC-Type Examination Certificate KEMA 02ATEX2021 X

Test documentation (continued)

	dated
2. Description (25 pages)	12.04.2001, 21.01.2002 and 01.02.2002
3. Drawings index sheet	01.02.2002

<http://www.krohne.com>

Production

KROHNE

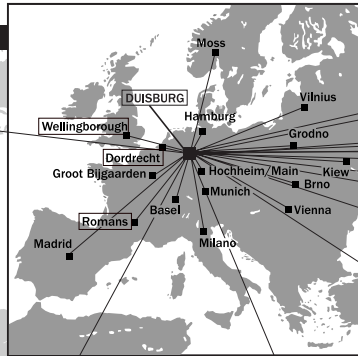

Australia

KROHNE Australia Pty Ltd.
Unit 19 No. 9, Hudson Ave.
Castle Hill 2154, NSW
TEL: +61(0)2-98948711
TEL: +61(0)2-98994855
e-mail: krohne@krohne.com.au

Austria

KROHNE Ges.m.b.H.
Wagramerstr. 81
Donauzentrum
A-1220 Wien
TEL: +43(0)1-2 03 45 32
FAX: +43(0)1-2 03 47 78
e-mail: kaut@via.at

Belgium

KROHNE Belgium N.V.
Brusselstraat 320
B-1702 Groot Bijgaarden
TEL: +32(0)2-4 66 00 10
FAX: +32(0)2-4 66 08 00
e-mail: krohne@krohne.be

Brazil

KROHNE Conaut
Controltes Automáticos Ltda.
Estrada Das Águas Espraiadas, 230 C.P.56
06835 - 080 EMBU - SP
TEL: +55(0)11-4785-2700
FAX: +55(0)11-4785-2768
e-mail: conaut@conaut.com.br

China

KROHNE Measurement Instruments Co. Ltd.
Room 7E, Yi Dian Mansion
746 Zhao Jia Bang Road
Shanghai 200030
TEL: +86(0)21-64677163
TEL: +86(0)21-64677166
FAX: +86(0)21-64677166
Cellphone: +86(0)139 1885890
e-mail: ksh@hw.com.cn

CIS

Kanex KROHNE Engineering AG
Business-Centre Planeta, Office 403
ul. Manistskaja 3
109147 Moscow/Russia
TEL: +7(0)095-9117165
TEL: +7(0)095-9117231
e-mail: krohne@oi.ru

Czech Republic

KROHNE CZ, spol. s r.o.
Soběšická 156
CZ-63800 Brno
TEL: +42(0)5-45 53 21 11
FAX: +42(0)5-45 522 00 93
e-mail: brno@krohne.cz

France

KROHNE S.A.
Usine des Ors
B.P. 98
F-26 103 Romans Cedex
TEL: +33(0)4 75 05 44 00
FAX: +33(0)4 75 05 00 48
e-mail: info@krohne.fr

Germany

KROHNE Messtechnik
GmbH & Co. KG
Ludwig-Krohne-Straße
D-47058 Duisburg
TEL: +49(0)203-301-0
FAX: +49(0)203-301 389
e-mail: krohne@krohne.de

India

KROHNE Marshall Ltd.
A-34/35, M.I.D.C.
Industrial Area, H-Block,
Pimpri Poona 411018
TEL: +91(0)20-744 20 20
FAX: +91(0)20-744 20 40
e-mail: pcu@sni.net

Italy

KROHNE Italia Srl.
Via V. Monti 75
I-20145 Milano
TEL: +39(0)2-4 30 06 61
FAX: +39(0)2-43 00 66 66
e-mail: krohne@krohne.it

Korea

Hankuk KROHNE
2 F, 599-1
Banghwa-2-Dong
Kangseo-Ku
Seoul
TEL: +82(0)2665-85 23-4
FAX: +82(0)2665-85 25
e-mail: flowtech@unitel.co.kr

Netherlands

KROHNE Altometer
Kerkeplaat 12
NL-3313 LC Dordrecht
TEL: +31(0)78-6306300
FAX: +31(0)78-6306390
e-mail: postmaster@krohne-altometer.nl

Norway

KROHNE Nederland B.V.
Kerkeplaat 12
NL-3313 LC Dordrecht
TEL: +31(0)78-6306200
FAX: +31(0)78-6306405
Service Direkt: +31(0)78-6306222
e-mail: info@krohne.nl

Norway

KROHNE Instrumentation A.S.
Ekholtveien 114
NO-1526 Moss
P.O. Box 2178, NO-1521 Moss
TEL: +47(0)69-264860
FAX: +47(0)69-267333
e-mail: postmaster@krohne.no
Internet: www.krohne.no

South Africa

KROHNE Pty. Ltd.
163 New Road
Halfway House Ext. 13
Midrand
TEL: +27(0)11-315-2685
FAX: +27(0)11-805-0531
e-mail: midrand@krohne.co.za

Spain

I.I. KROHNE Iberia, S.r.L.
Polígono Industrial Nilo
Calle Brasil, n.º 5
E-28806 Alcalá de Henares-Madrid
TEL: +34(0)91-8 83 21 52
FAX: +34(0)91-8 83 48 54
e-mail: krohne@krohne.es

Switzerland

KROHNE AG
KROHNE AG
Ulferstr. 90
CH-4019 Basel
TEL: +41(0)61-638 30 30
FAX: +41(0)61-638 30 40
e-mail: info@krohne.ch

United Kingdom

KROHNE Ltd.
Rutherford Drive
Park Farm Industrial Estate
Wellingtonborough
Northants NN8 6AE, UK
TEL: +44(0)19 33-408 500
FAX: +44(0)19 33-408 501
e-mail: info@krohne.co.uk

USA

KROHNE Inc.
7 Dearborn Road
Peabody, MA 01960
TEL: +1-978 535-60 60
FAX: +1-978 535-17 20
e-mail: krohne@krohne.com

Overseas Representatives

Algeria	Japan
Argentina	Jordan
Bulgaria	Kuwait
Cameroon	Morocco
Canada	Mauritius
Chile	Mexico
Columbia	New Zealand
Croatia	Pakistan
Denmark	Poland
Ecuador	Portugal
Egypt	Saudi Arabia
Finland	Senegal
French Antilles	Singapore
Greece	Slovakia
Guinea	Slovenia
Hong Kong	Sweden
Hungary	Taiwan
Indonesia	Thailand
Ivory Coast	Turkey
Iran	Tunisia
Ireland	Venezuela
Israel	Yugoslavia

Other Countries:

KROHNE Messtechnik
GmbH & Co. KG
Ludwig-Krohne-Str.
D-47058 Duisburg
TEL: +49(0)203-301 389
FAX: +49(0)203-301 389
e-mail: export@krohne.de