

**Addition to the
installation and operating instructions**

**ALTOFLUX IFS 4000 F-EEEx
PROFILUX IFS 5000 F-EEEx
VARIFLUX IFS 6000 F-EEEx**

**Electromagnetic primary head
(remote design)**



Variable area flowmeters

Vortex flowmeters

Flow controllers

Electromagnetic flowmeters

Ultrasonic flowmeters

Mass flowmeters

Level measuring instruments

Communications technology

Engineering systems & solutions

Switches, counters, displays and recorders

Heat metering

Pressure and temperature

WARNING ! No changes regarding safety may be made to the devices. Unauthorized changes might affect the explosion safety of the devices.

Be sure to follow these instructions !

IMPORTANT !	<ul style="list-style-type: none">• The prescriptions and regulations as well as the electrical data described in the EC-type examination certificate must be obeyed.• Beside the instructions for electrical installations in non-hazardous locations according to the applicable national standard (e.g. IEC 364), especially the regulations in EN 60079-14 "Electrical installations in hazardous locations" or equivalent national standard must be followed.• Installation, establishment, utilization and maintenance are only allowed to be executed by personnel with an education in explosion safety !
--------------------	---

These additional instructions are an extension to the "Installation and Operating Instructions" and only apply to the EEx version of the IFS 4000 F, IFS 5000 F and IFS 6000 F electromagnetic primary heads in remote design. All technical information described in the "Installation and Operating Instructions" are applicable, when not specifically excluded, completed or replaced by the instructions in these additional instructions.

Contents

1	System components	3
1.1	General information ALTOFLUX IFS 4000 F-EEx	3
1.1.1	Mechanical construction	5
1.1.2	Data plates of ALTOFLUX IFS 4000 F-EEx	5
1.2	General information PROFILUX IFS 5000 F-EEx	6
1.2.1	Mechanical construction	7
1.2.2	Data plates of PROFILUX IFS 5000 F-EEx	7
1.3	General information VARIFLUX IFS 6000 F-EEx	8
1.3.1	Mechanical construction	9
1.3.2	Data plates of VARIFLUX IFS 6000 F-EEx	9
1.4	Block diagram	10
2	Electrical connection	11
2.1	Primary fuse connection (only for IFS 5000 F-EEx and IFS 6000 F-EEx)	11
2.2	Fuse protection of field coil circuit	11
2.3	Equipotential bonding system	11
2.4	Intermediate junction box ZD-EEx	11
2.5	Connecting cables	12
2.6	Connection diagrams	14
3	Maintenance	16
4	Declaration of conformity	17
5	EC-type examination certificates	18
5.1	ALTOFLUX IFS 4000 F-EEx certificate	18
5.2	PROFILUX IFS 5000 F-EEx certificate	24
5.3	VARIFLUX IFS 6000 F-EEx certificate	27

1 System components

1.1 General information ALTOFLUX IFS 4000 F-EEEx

The ALTOFLUX IFS 4000 F-EEEx electromagnetic primary head in remote design (F = field) complies with the European Directive 94/9 EC (ATEX 100a) and has been approved for hazardous classified locations of Zone 1 and 2 by the KEMA conform to the European Standards of the EN 500xx series.

They have the following approval number:

KEMA 01 ATEX 2263 X

The IFS 4000 F-EEEx primary head is designed for ambient temperatures in the range of -40°C up to +60°C inclusive. The IFS 4000 F-EEEx primary head in remote design is connected to an associated signal converter, e.g. IFC 090 F/...-EEEx, which is also approved in accordance with the European Directive 94/9 EC (ATEX 100a). The signal converter is installed on a distance from the IFS 4000 F-EEEx primary head and connected via a field coil cable, an electrode cable and a bonding wire.

The IFS 4000 F-EEEx primary head in remote design can be installed in environments that are classified as Zone 1 or Zone 2 hazardous locations. The maximum permissible process liquid temperature is dependent on the maximum ambient temperature (Ta) that can occur in that environment too.

For installation of the IFS 4000 F-EEEx primary head please conform to the following listed three temperature classification tables on the next page. The first column lists the temperature classes for gases and the second one the rating for dusts.

The **first table** applies to meter sizes larger and equal to DN300, which have type of protection increased safety "EEEx e".

The **second table** applies to meter sizes DN25 up to DN150 inclusive, which are performed as type of protection flameproof enclosure "EEEx d".

The **third table** applies to meter sizes DN10-20 (type protection increased safety "EEEx e" and encapsulation "EEEx m") and DN200-300 (increased safety "EEEx e" and powder filling "EEEx q").

The following three tables only give the maximum possible temperatures for a lining material inside the measuring tube of the primary head that consists of PFA. For information on temperature restrictions of other lining materials, see Standard Installation and Operating Instructions.

Temperature classification of meter sizes larger than DN300

Temperature class	Max. surface temperature	Maximum process liquid temperature		
		Ta ≤ 40 °C	Ta ≤ 50 °C	Ta ≤ 60 °C
T6	T 85°C	60°C	60°C	60°C
T5	T100°C	80°C	75°C	75°C
T4	T135°C	115°C	115°C	115°C
T3	T180°C	160°C	150°C	140°C
Use heat-resistant cables above		-	145°C	110°C

Temperature classification of meter sizes DN25...150

Temperature class	Max. surface temperature	Maximum process liquid temperature		
		Ta ≤ 40 °C	Ta ≤ 50 °C	Ta ≤ 60 °C
T6	T 85°C	70°C	70°C	70°C
T5	T100°C	85°C	85°C	85°C
T4	T135°C	120°C	120°C	120°C
T3	T180°C	180°C	180°C	180°C
Use heat-resistant cables above		-	155°C	105°C

Temperature classification of meter sizes DN10-20 and DN200-300

Temperature class	Max. surface temperature	Maximum process liquid temperature		
		Ta ≤ 40 °C	Ta ≤ 50 °C	Ta ≤ 60 °C
T6	T 85°C	75°C	70°C	70°C
T5	T100°C	95°C	90°C	75°C
T4	T135°C	130°C	115°C	75°C
T3	T150°C	150°C	115°C	75°C

IMPORTANT !	The maximum process liquid temperature values in the above listed tables only apply to a lining material of PFA (maximum operating temperature of 200°C). For other lining materials (e.g. rubber) is a lower process liquid temperature required for safe operation. See the standard Installation and Operating Instructions for detailed information about other lining materials.
--------------------	---

The IFS 4000 F-Ex is marked with one of the following EEx-codes, which depends on the meter size range (see table below).

Marking IFS 4000 F-Ex-code

Meter size	EEx-code
DN10... DN20	II 2GD EEx me ib IIC T6...T3
DN25... DN150	II 2GD EEx de ib IIC T6...T3
DN200...DN300	II 2GD EEx qe ib IIC T6...T3
larger than DN300	II 2GD EEx e ib IIC T6...T3

Also see the EC-type examination certificate in Section 5 of these additional instructions.

1.1.1 Mechanical construction

The IFS 4000 F-EEEx primary head is the measuring unit of the flowmetering system (see block diagram in section 1.4). It contains two field coils and two electrodes in type of protection intrinsic safety category "ib" according to EN 50020. The type of protection of the field coils depends on the meter size:

DN10...DN20	Increased safety "e" according to EN 50019 and encapsulation "m" according to EN 50028
DN25...DN150	Flameproof enclosure "d" according to EN 50018
DN200...DN300	Increased safety "e" according to EN 50019 and powder filling "q" according to EN 50017
larger than DN300	Increased safety "e" according to EN 50019

The electrode circuits are wired by separate shielded cables and marked by the sheath color (white and purple). The intrinsical safe "EEEx ib" electrode circuits inside the IFS 4000 F-EEEx primary head have the following maximum values (entity parameters):

Maximum input voltage	$U_{\max} = 20 \text{ V}$
Maximum input current	$I_{\max} = 175 \text{ mA}$
Maximum internal capacitance	$C_i = 0$
Maximum internal inductance	$L_i = 0$

The two field coils inside the primary head are connected in series and have a maximum resistance of 85Ω per coil with a wire diameter of at least 0.25 mm and insulation class H ($T_{\max} \geq 180^\circ\text{C}$) according to IEC 85. The field coils are supplied with a square-wave signal with a voltage of $\pm 40 \text{ V}$ and a nominal current of 125 mA. The coil circuit is protected by two 160 mA series fuses, which are installed inside the associated signal converter unit (e.g. IFC 090 F/...-EEEx).

NOTE: In case of meter size DN200-300 the coil housing is factory sealed. Do not open.

1.1.2 Data plates of ALTOFLUX IFS 4000 F-EEEx

Data plate 1

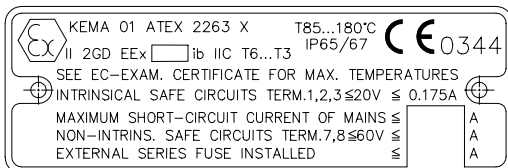

Data plate 2



1.2 General information PROFIFLUX IFS 5000 F-EEEx

The PROFIFLUX IFS 5000 F-EEEx electromagnetic primary head in remote design (F = field) complies with the European Directive 94/9 EC (ATEX 100a) and has been approved for hazardous classified locations of Zone 1 and 2 by the KEMA conform to the European Standards of the EN 500xx series.

They have the following approval number:

KEMA 02 ATEX 2024 X

The IFS 5000 F-EEEx primary head with meter sizes DN2.5 up to and including DN15 is designed for ambient temperatures in the range of -40°C to +60°C. The meter sizes DN25 up to DN100 inclusive are designed for ambient temperatures ranging from -20°C to +60°C.

The IFS 5000 F-EEEx primary head in remote design can be installed in environments that are classified as Zone 1 or Zone 2 hazardous locations. The maximum permissible process liquid temperature is dependent on the maximum ambient temperature (Ta) that can occur in that environment too.

For installation of the IFS 5000 F-EEEx primary head please conform to the below listed temperature classification table. The first column lists the temperature classes for gases and the second one the rating for dusts.

The table below applies for all meter sizes D2.5 up to and including DN100.

Temperature classification

Temperature class	Max. surface temperature	Maximum process liquid temperature		
		Ta ≤ 40 °C	Ta ≤ 50 °C	Ta ≤ 60 °C
T6	T 80°C	65°C	65°C	65°C
T5	T 95°C	85°C	85°C	80°C
T4	T130°C	125°C	125°C	120°C
T3	T180°C	180°C	165°C	145°C
Use heat-resistant cables above		165°C	130°C	100°C

The IFS 5000 F-EEEx primary head in remote design is connected to a signal converter, e.g. IFC 090 F/...-EEEx, which is also approved according to the European Directive 94/9 EC (ATEX 100a). The signal converter is installed on a distance from the IFS 5000 F-EEEx primary head and connected via a field coil cable, an electrode cable and a bonding wire.

The IFS 5000 F-EEEx is marked with the following EEx-code:

II 2GD EEx me ib IIC T6...T3

Also see the EC-type examination certificate in Section 5 of these additional instructions.

1.2.1 Mechanical construction

The IFS 5000 F-EEx primary head is the measuring unit of the flowmetering system (see block diagram in section 1.4). It contains two field coils and two electrodes in type of protection intrinsic safety category "ib" according to EN 50020. The type of protection of the field coils is Encapsulation "m" according to EN 50028 and Increased Safety "e" according to EN 50019.

The electrode circuits are wired by separate shielded cables and marked by the color of the outer insulation sheath of the cable (white and purple). The intrinsic safe "EEx ib" electrode circuits inside the IFS 5000 F-EEx primary head have the following maximum values (entity parameters):

Maximum input voltage	$U_{\max} = 20 \text{ V}$
Maximum input current	$I_{\max} = 170 \text{ mA}$
Maximum internal capacitance	$C_i = 0$
Maximum internal inductance	$L_i = 0$

The two field coils inside the primary head are connected in series and have a maximum resistance of approximately 60Ω per coil with a wire diameter of at least 0.25 mm and insulation class H ($T_{\max} \geq 180^\circ\text{C}$) according to IEC 85. The field coils are supplied with a square-wave signal with a voltage of $\pm 40 \text{ V}$ and a nominal current of 125 mA. The coil circuit is protected by two 160 mA series fuses, which are installed inside the associated signal converter unit (e.g. IFC 090 F/...-EEx).

1.2.2 Data plates of PROFIFLUX IFS 5000 F-EEx

Data plate 1

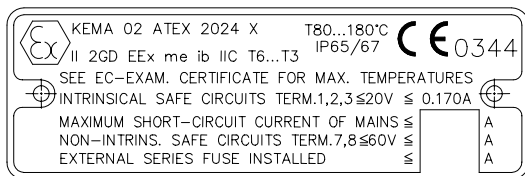

Data plate 2

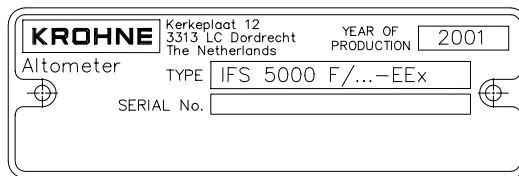

1.3 General information VARIFLUX IFS 6000 F-EEEx

The VARIFLUX IFS 6000 F-EEEx electromagnetic primary head in remote design (F = field) complies with the European Directive 94/9 EC (ATEX 100a) and has been approved for hazardous classified locations of Zone 1 and 2 by the KEMA conform to the European Standards of the EN 500xx series.

They have the following approval number:

KEMA 02 ATEX 2038 X

The IFS 6000 F-EEEx primary head is designed for ambient temperatures in the range of -40°C up to +60°C inclusive. The IFS 6000 F-EEEx primary head in remote design is connected to a associated signal converter, e.g. IFC 090 F/...-EEEx, which is also approved in accordance with the European Directive 94/9 EC (ATEX 100a). The signal converter is installed on a distance from the IFS 6000 F-EEEx primary head and connected via a field coil cable, an electrode cable and a bonding wire.

The IFS 6000 F-EEEx primary head in remote design can be installed in environments that are classified as Zone 1 or Zone 2 hazardous locations. The maximum permissible process liquid temperature is dependent on the maximum ambient temperature (T_a) that can occur in that environment too.

For installation of the IFS 6000 F-EEEx primary head please conform to the below listed temperature classification table. The first column lists the temperature classes for gases and the second one the rating for dusts.

Temperature classification

Temperature class	Max. surface temperature	Maximum process liquid temperature		
		$T_a \leq 40\text{ °C}$	$T_a \leq 50\text{ °C}$	$T_a \leq 60\text{ °C}$
T6	T 80°C	70°C	70°C	70°C
T5	T 95°C	85°C	85°C	85°C
T4	T130°C	120°C	120°C	120°C
T3	T190°C	180°C	180°C	165°C
Use heat-resistant cables above		-	160°C	115°C

The IFS 6000 F-EEEx is marked with one of the following EEx-codes, which depends on the meter size range (see table below).

Marking IFS 6000 F-EEEx code

Meter size	EEx-code
DN2.5...DN15	II 2GD EEx me ib IIC T6...T3
DN25...DN80	II 2GD EEx de ib IIC T6...T3

Also see the EC-type examination certificate in section 5 of these additional instructions.

1.3.1 Mechanical construction

The IFS 6000 F-EEEx primary head is the measuring unit of the flowmetering system (see block diagram in section 1.4). It contains two field coils and two electrodes in type of protection intrinsic safety category "ib" according to EN 50020. The type of protection of the field coils depends on the meter size:

DN2.5...DN15	Encapsulation "m" according to EN 50028 and Increased safety "e" according to EN 50019
DN25...DN150	Flameproof enclosure "d" according to EN 50018

The electrode circuits are wired by separate shielded cables and marked by the sheath color (white and purple). The intrinsical safe "EEEx ib" electrode circuits inside the IFS 6000 F-EEEx primary head have the following maximum values (entity parameters):

Maximum input voltage	$U_{max} = 20 \text{ V}$
Maximum input current	$I_{max} = 170 \text{ mA}$
Maximum internal capacitance	$C_i = 0$
Maximum internal inductance	$L_i = 0$

The two field coils inside the primary head are connected in series and have a maximum resistance of 85Ω per coil with a wire diameter of at least 0.25 mm and insulation class H ($T_{max} \geq 180^\circ\text{C}$) according to IEC 85. The field coils are supplied with a square-wave signal with a voltage of $\pm 40 \text{ V}$ and a nominal current of 125 mA. The coil circuit is protected by two 160 mA series fuses, which are installed inside the associated signal converter unit (e.g. IFC 090 F/...-EEEx).

1.3.2 Data plates of VARIFLUX IFS 6000 F-EEEx

Data plate 1

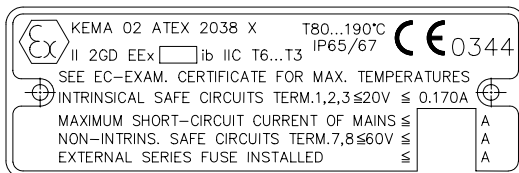

Data plate 2



1.4 Block diagram

Flowmetering systems designed for use in hazardous areas consist of the following components resp. instruments.

Block diagram of flowmetering system with IFS x000 F- EEx

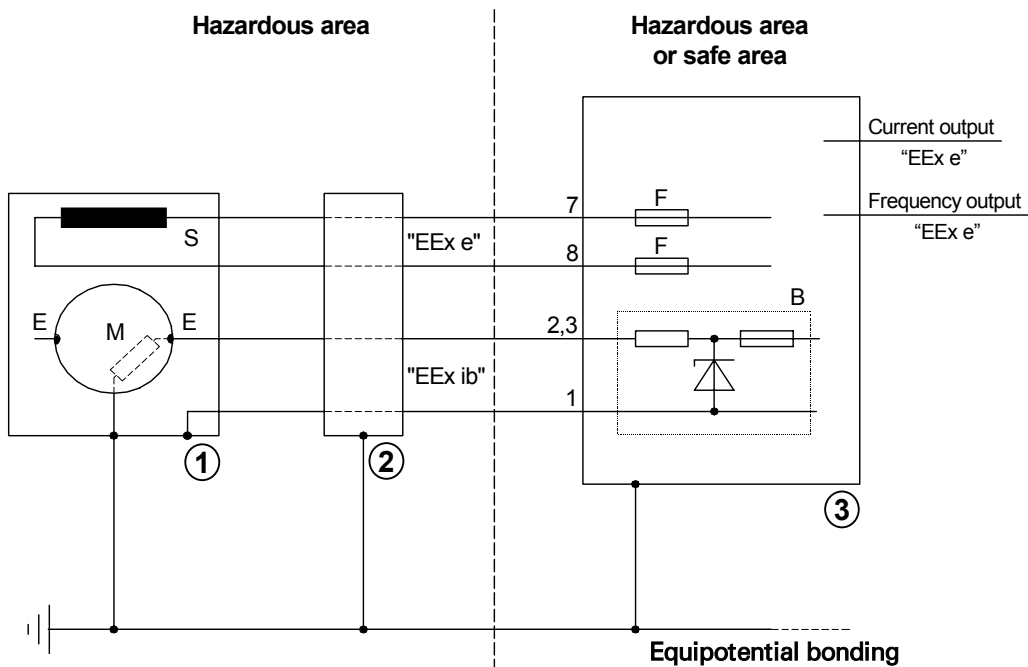

The block diagram above shows the principle of a flowmetering system with IFS x000 F-EEx primary head, that is suitable for hazardous locations. An explanation of the several shown items follows:

1. IFS x000 F-EEx primary head.
2. ZD-EEx intermediate junction box. This junction box is used for certain process liquid temperatures that result in higher temperatures at the cable entries resp. branching point of the connecting cable(s) than that is allowed for normal cables. The intermediate junction box is used to keep the heat-resistant cabling as short as possible (max. 5 m), because of the higher costs.
3. Signal converter unit (e.g. IFC 090 F/...-EEx). The signal converter unit contains the electronics that drives the primary head. It can be located in a hazardous area, in which case the IFC 090 F/...-EEx with flameproof housing is used. When installed in a safe (non-hazardous) area, alternatively to this version the standard non-EEx version can be used. The standard version is namely also provided with a safety barrier to drive the "EEx ib" electrodes of the primary head.

Remaining items:

- M** Measuring tube
- E** Electrode
- S** Magnetic field coil
- F** Field circuit fuse (installed in associated signal converter unit).
- B** Safety barrier with intrinsically safe "ib" outputs.

2 Electrical connection

2.1 Primary fuse connection (only for IFS 5000 F-EEEx and IFS 6000 F-EEEx)

For all meter sizes (DN2.5 up to and including DN100 in case of IFS 5000 F-EEEx, DN2.5 up to and including DN15 in case of IFS 6000 F-EEEx) which also have type of protection Encapsulation "m" according to EN 50028, the associated signal converter may only be connected to a mains supply with a prospective **short-circuit current** of maximum 1500 A for the 100...230 Vac mains supplies or 300 A for 24 Vac/dc mains supplies.

2.2 Fuse protection of field coil circuit

The field coil circuit is protected against over-current by two fuses of type Wickmann TR5 with a nominal rating of T160mA. These fuses are soldered into the amplifier printed circuit board of the electronics unit of the associated signal converter (e.g. IFC 090 F/...-EEEx).

2.3 Equipotential bonding system

The IFS x000 F-EEEx electromagnetic primary head **must always** be incorporated into the equipotential bonding system. Therefore the bonding conductor with a cross-sectional area of at least 4 mm² (i.e. AWG 10) must be connected to the external U-clamp terminal M5 that is mounted to the connecting flange between primary head's housing and junction box.

The U-clamp terminal is made of nickel-plated brass or stainless steel to protect it against corrosion. Make sure that the core of the bonding wire is properly mounted under the U-clamp and that the screw is tightly fixed.

2.4 Intermediate junction box ZD-EEEx

For safety reasons, standard cables with a rubber or thermoplastic insulation sheath may only be used up to a continuous operating temperature of 70°C at the cable entry and 80°C at the branching point of the connecting cables. In case that the temperature at the above mentioned parts exceed the maximum values, heat-resistant cables must be installed at the IFS x000 F-EEEx primary head in remote design.

Also see the EC-type examination certificate of the primary head.

The table below summarizes the conditions for use of heat-resistant cables for the IFS x000 F-EEEx primary head.

Use of heat-resistant cables

Primary head	Meter size	Ambient temperature	Process liquid temperature
IFS 4000 F-EEEx	DN25 - 150	≤ 40°C ≤ 50°C ≤ 60°C	not required ≥ 155°C ≥ 105°C
	≥ DN200	≤ 40°C ≤ 50°C ≤ 60°C	not required ≥ 145°C ≥ 110°C
IFS 5000 F-EEEx	DN2.5 - 100	≤ 40°C ≤ 50°C ≤ 60°C	≥ 165°C ≥ 130°C ≥ 100°C
IFS 6000 F-EEEx	DN2.5 - 80	≤ 40°C ≤ 50°C ≤ 60°C	not required ≥ 160°C ≥ 115°C

In case that heat-resistant cables are required, install the intermediate junction box ZD-EEEx at a distance up to 5 m from the IFS x000 F-EEEx primary head. Connect the heat-resistant cables (cables type D and E in next section) between the primary head's junction box and the intermediate junction box ZD-EEEx. The standard cables (types B and C) can be used between signal converter unit and intermediate junction box. See the second connection diagram for details (section 2.6).

The silicone rubber insulated connecting cable for the magnetic field coils circuit must be protected against mechanical damages between the primary head and intermediate junction box by a conduit system with edge protections. Intermediate box ZD-EEEx has terminals with type of protection increased safety "EEEx e" according to EN 50019. The intermediate box is incorporated into the equipotential bonding system of the installation through its external clamp terminal.

2.5 Connecting cables

- Notes:**
- The below described cables are shown in the connection diagrams. See section 2.6.
 - In case that heat-resistant cables have to be used - depends on meter size, process liquid and ambient temperature - the so-called intermediate junction box type ZD-EEEx must be used. See General information in Section 1 for details.
 - The maximum length of the connecting cables between the IFS x000 F-EEEx primary head and the associated signal converter is for safety reasons limited at 50 m. A shorter cable length can be prescribed for measurement technical reasons, see therefore the standard Installation and Operating Instructions.

Cable A

Signal cable for current output and binary outputs (pulse and status output). The cable parameters must be in accordance with the regulations in the EN 60079-14 "Electrical installations in hazardous locations" or an equivalent national standard.

Cable B

Power supply cable. The cable parameters must be in accordance with the regulations of the EN 60079-14 "Electrical installations in hazardous locations" or an equivalent national standard.

Rated voltage	$\geq 500 \text{ V}$
Examples	H07...-, H05...-
Cross-sectional area of core	1.5 to 2.5 mm ²

Cable C

	Type DS blue Intrinsical safe, with double shielding	Cable constants (typical values at $T_a = 20^\circ\text{C}$)
	1 Stranded drain wire, 1st shield, 1.5 mm^2 2 Insulation 3 Stranded wire, 0.5 mm^2 4 Special foil, 1st shield 5 Insulation 6 Mu-metal foil, 2nd shield 7 Stranded drain wire, 2nd shield, 0.5 mm^2 8 Outer sheath (flame-retardant)	$C'_{3/3}$ 60 pF/m (1 kHz) $C'_{3/4}$ 110 pF/m (1 kHz) $C'_{4/6}$ 290 pF/m (1 kHz) $L'_{3/3}$ 0.85 $\mu\text{H/m}$ (1 kHz) $L'_{3/4}$ 0.60 $\mu\text{H/m}$ (1 kHz) R'_{3} 37 m Ω /m R'_{4+1} 12 m Ω /m

Cable D:

Intrinsical safe, with **single** shielding. Heat-resistant conform to VDE 0165/02.91.

Properties

Continuous service temperature	$\geq 120^\circ\text{C}$
Test voltage	$\geq 500\text{ V}$
Capacitance: core/core	$\leq 200\text{ pF/m}$
core/shield	$\leq 200\text{ pF/m}$
Inductance: core/core	$\leq 1\mu\text{H/m}$
Cable length	$\leq 5\text{ m}$
Single-wire- \varnothing : core/shield	$\geq 0.1\text{ mm}$
Cross-sectional area of core	$0.5\text{ to }1.5\text{ mm}^2$
Sheath	light-blue or in other way color-coded as intrinsical safe, flame-retardant.
Example	Silicone rubber insulated, shielded control cable.

Cable E:

Non-intrinsical safe, **2-core** without shielding. Heat-resistant conform to VDE 0165/02.91.

Properties

Continuous service temperature	$\geq 120^\circ\text{C}$
Test voltage	$\geq 500\text{ V}$
Cross-sectional area of core	1.5 mm^2

Bonding conductor:

Cross-sectional area	Max. 4 mm^2
----------------------	----------------------

2.6 Connection diagrams

Connection diagram 1: Standard cables

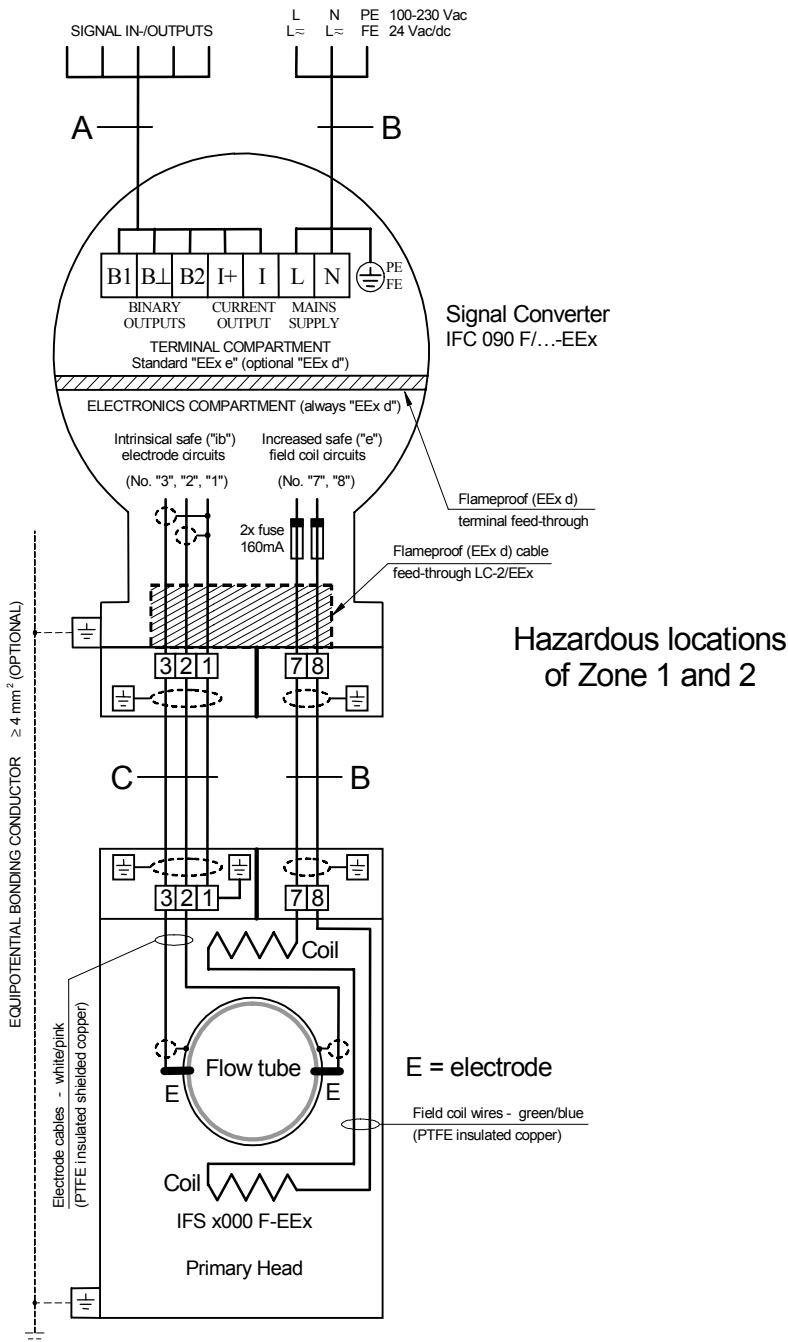

Connection diagram 2: Use of heat-resistant cables

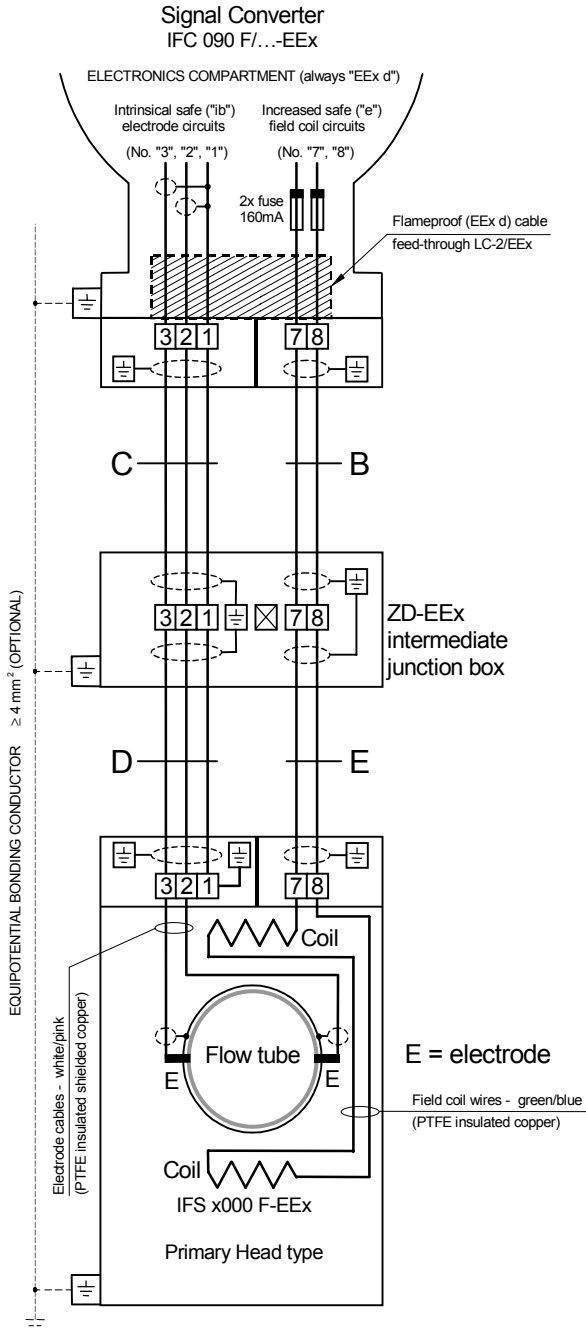

Hazardous locations
of Zone 1 and 2

3 Maintenance

The IFS x000 F-EEEx primary head is maintenance free with regard to the flowmetering properties.

For IFS 4000 F-EEEx it is recommended to check the flameproof enclosure of meter sizes DN25 up to and including DN150, within the scope of the periodical inspections, which are required for electrical apparatus that are installed and used in hazardous classified locations.

Regarding the IFS 5000 F-EEEx no special inspections are required for this electrical apparatus, even within the scope of the periodical inspections.

For IFS 6000 F-EEEx it is recommended to check the flameproof enclosure of meter sizes DN25 up to and including DN80, within the scope of the periodical inspections, which are required for electrical apparatus that are installed and used in hazardous classified locations.

4 Declarations of conformity



EC Declaration of Conformity

We,

KROHNE Altometer
Kerkeplaat 12
3313 LC Dordrecht
The Netherlands

Declare under our sole responsibility that the products

Compact electromagnetic flowmeter types:

IFS 4000 F-EEEx
IFS 5000 F-EEEx
IFS 6000 F-EEEx

Fulfill the requirements of following EC directives:

- ATEX Directive 94/9/EC
- EMC Directive 89/336/EC

The IFS 4000 F-EEEx, IFS 5000 F-EEEx and IFS 6000 F-EEEx flowmeters are designed and manufactured conform following harmonized standards:

- EN 50 014 : 1997
- EN 50 018 : 2000 (only for IFS 4000 F-EEEx and IFS 6000 F-EEEx)
- EN 50 019 : 2000
- EN 50 020 : 1994
- EN 50 028 : 1987 (only for IFS 5000 F-EEEx and IFS 6000 F-EEEx)
- EN 50 281-1-1 : 1998

- EN 50 081-1
- EN 50 082-2
- EN 61 010-1

The IFS 4000 F-EEEx, IFS 5000 F-EEEx and IFS 6000 F-EEEx are respectively examined and type-approved under EC-type examination certificates KEMA 01 ATEX 2263 X, KEMA 02 ATEX 2024 X or KEMA 02 ATEX 2038 X. The KROHNE Altometer quality assurance system is approved by KEMA Registered Quality b.v.

Dordrecht, 02.10.2002

A handwritten signature in black ink, appearing to be "L. Ijunker".

L. Ijunker
(General Manager)

5 EC-type examination certificates

5.1 ALTOFLUX IFS 4000 F-EEEx certificate

KEMA 



(1) **EC-TYPE EXAMINATION CERTIFICATE**

(2) Equipment or protective system intended for use in potentially explosive atmospheres – Directive 94/9/EC

(3) EC-Type Examination Certificate Number: **KEMA 01ATEX2263 X**

(4) Equipment or protective system: **Electromagnetic flowmeter primary head, types IFS 4000 F/...EEEx and MGS 4000 F/...EEEx**

(5) Manufacturer: **Krohne Altometer**

(6) Address: **Kerkeplaat 12, 3313 LC Dordrecht, The Netherlands**

(7) This equipment or protective system and any acceptable variation thereto is specified in the schedule to this certificate and the documents therein referred to.

(8) KEMA Quality B.V., notified body number 0344 in accordance with Article 9 of the Council Directive 94/9/EC of 23 March 1994, certifies that this equipment or protective system has been found to comply with the Essential Health and Safety Requirements relating to the design and construction of equipment and protective systems intended for use in potentially explosive atmospheres given in Annex II to the Directive.

The examination and test results are recorded in confidential report no. 2016360.

(9) Compliance with the Essential Health and Safety Requirements has been assured by compliance with:

EN 50014 : 1997	EN 50018 : 2000	EN 50019 : 2000
EN 50020 : 1994	EN 50281-1-1 : 1998	

(10) If the sign "X" is placed after the certificate number, it indicates that the equipment or protective system is subject to special conditions for safe use specified in the schedule to this certificate.

(11) This EC-Type Examination Certificate relates only to the design, examination and tests of the specified equipment or protective system in accordance with the Directive 94/9/EC. Further requirements of the Directive apply to the manufacturing process and supply of this equipment or protective system. These are not covered by this certificate.

(12) The marking of the equipment or protective system shall include the following:

 II 2 GD **EEEx e Ib IIC T6...T3** or **EEEx de Ib IIC T6...T3**
T 85...180 °C

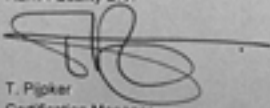
Amhem, 25 March 2002
KEMA Quality B.V.

T. Pijker
Certification Manager

* This Certificate may only be reproduced in its entirety and without any change

KEMA Quality B.V.
Utrechtseweg 310, 6812 AR Amhem, The Netherlands
P.O. Box 5185, 6802 ED Amhem, The Netherlands
Telephone +31 26 3 56 20 08, Telefax +31 26 3 52 58 00

ACCREDITED BY THE
DUTCH COUNCIL FOR
ACCREDITATION



Page 1/4

(13) **SCHEDULE**

(14) **to EC-Type Examination Certificate KEMA 01ATEX2263 X**

(15) **Description**

The Electromagnetic flowmeter primary head, types IFS 4000 F/...EEx and MGS 4000 F/...EEx is used to convert the flow of a conducting fluid into an electrical signal. An associated flowmeter transmitter is used to supply the field coils of the primary head and to convert the measured electrode signal into an output signal.

The field coils of the primary heads are in type of explosion protection flameproof enclosure "d" (sizes DN25 - DN150) or increased safety "e" (sizes DN200 - DN3000), the electrodes are in type of explosion protection intrinsic safety "i" and the terminal compartment is in type of explosion protection increased safety "e".

The maximum surface temperature $T_{85} \dots 180$ °C is based on a maximum ambient temperature of 60 °C.

Electrical data

Field coil circuit $U \leq 40$ V (pulsed)
 $I \leq 125$ mA (fuse protected)

The field coils circuit is protected by two 160 mA fuses in the coil excitation circuit of the associated transmitter.

Electrodes circuit in type of explosion protection intrinsic safety EEx ib IIC, only for connection to a certified intrinsically safe circuit, with the following maximum values:

$$\begin{aligned} U_i &= 20 \text{ V} \\ I_i &= 175 \text{ mA} \end{aligned}$$

The effective internal capacitance and inductance are negligibly small.

The signal circuit is operationally grounded.

Installation instructions

For use in potentially explosive atmospheres of flammable gases, fluids or vapours:
The cable entry device shall be in type of explosion protection increased safety "e", suitable for the conditions of use and correctly installed.

For use in the presence of combustible dust:
The cable entry device shall be in type of equipment Category II 2 D, suitable for the conditions of use and correctly installed.

Unused openings shall be closed with suitable certified closing elements.

Routine tests

Each welded primary head in type of explosion protection flameproof enclosure "d" must be submitted to the routine overpressure test according to EN 50018, Clause 16, at a test pressure of 13,5 bar during one minute.

(13)

SCHEDULE

(14)

to EC-Type Examination Certificate KEMA 01ATEX2263 X

Routine tests (continued)

Each primary head shall withstand a test voltage of 1500 V during one minute without breakdown between the field coils circuit and the intrinsically safe sensor circuit. Each primary head in type of explosion protection increased safety "e" shall additionally withstand a test voltage of 1500 V during one minute without breakdown between the field coils circuit and the enclosure.

(16) **Report**

KEMA No. 2016360.

(17) **Special conditions for safe use**

Ambient temperature range $-40\text{ }^{\circ}\text{C}$... $+60\text{ }^{\circ}\text{C}$.

The relation between temperature class, maximum surface temperature, maximum process temperature and ambient temperature is shown in the following tables:

a) Meter size DN25 - DN150:

Temperature class	Max. surface temperature	Max. process temperature		
		Ta ≤ 40 °C	Ta ≤ 50 °C	Ta ≤ 60 °C
T6	T 85 °C	70 °C	70 °C	70 °C
T5	T 100 °C	85 °C	85 °C	85 °C
T4	T 135 °C	120 °C	120 °C	120 °C
T3	T 180 °C	180 °C	180 °C	180 °C

A heat resistant cable with a continuous operating temperature of at least 120 °C must be used for conditions as specified below.

- Ta ≤ 50 °C and process temperature ≥ 155 °C, or
- Ta ≤ 60 °C and process temperature ≥ 105 °C.

b) Meter size DN200 - DN3000:

Temperature class	Max. surface temperature	Max. process temperature		
		Ta ≤ 40 °C	Ta ≤ 50 °C	Ta ≤ 60 °C
T6	T 85 °C	60 °C	60 °C	60 °C
T5	T 100 °C	80 °C	75 °C	75 °C
T4	T 135 °C	115 °C	115 °C	115 °C
T3	T 180 °C	160 °C	150 °C	140 °C

A heat resistant cable with a continuous operating temperature of at least 120 °C

- Ta ≤ 60 °C and process temperature ≥ 110 °C.



- (13) **SCHEDULE**
- (14) **to EC-Type Examination Certificate KEMA 01ATEX2263 X**
- (18) **Essential Health and Safety Requirements**
Covered by the standards listed at (9).
- (19) **Test documentation**
1. EC-Type Examination Certificate KEMA 01ATEX2228 U
Certificate of Conformity PTB No. Ex-90.C.2003 X
dated
 2. Description (14 pages) 06.03.2002
 3. Drawings index sheet 06.03.2002

AMENDMENT 1

to EC-Type Examination Certificate KEMA 01ATEX2263 X

Manufacturer: **Krohne Altimeter**

Address: **Kerkeplaat 12, 3313 LC Dordrecht, The Netherlands**

Description

The Electromagnetic flowmeter primary heads, types IFS 4000 F/...EEx and MGS 4000 F/...EEx are extended with sizes DN10 - DN20 and DN200 - DN300. These primary heads are in type of explosion protection encapsulation "m" (DN10 - DN20) or powder filling "q" (DN200 - DN300), and are provided with measuring electrodes in type of explosion protection intrinsic safety EEx ib IIC. The terminal compartment is in type of explosion protection increased safety "e".

The primary heads shall be marked with the following code

DN10 - DN20:  II 2 GD EEx me ib IIC T6...T3,
T 85...150 °C

DN200 - DN300:  II 2 GD EEx qe ib IIC T6...T3,
T 85 - 150 °C

Routine tests

The following routine tests of EN 50028 must be carried out on the primary heads with sizes DN10 - DN20:

- Clause 7.1: Visual check.
- Clause 7.2: Each primary head shall withstand a test voltage of 1500 V during one minute without breakdown between the field coils circuit and the enclosure and between the field coils circuit and the intrinsically safe sensor circuit.
- Clause 7.3: Checking the electrical data.

The following routine test of EN 50017 must be carried out on the primary heads with sizes DN200 - DN300:

- Clause 13.2: Electric strength test of the filling material.

The routine overpressure test according to EN 50017, Clause 13.1, is not required since the type test has been made at a static pressure of 2 bar.

Special conditions for safe use

The relation between temperature class, maximum surface temperature, maximum process temperature and ambient temperature is shown in the following table:

Temperature class	Max. surface temperature	Max. process temperature		
		Ta ≤ 40 °C	Ta ≤ 50 °C	Ta ≤ 60 °C
T6	T 85 °C	75 °C	70 °C	70 °C
T5	T 100 °C	95 °C	90 °C	75 °C
T4	T 135 °C	130 °C	115 °C	75 °C
T3	T 150 °C	150 °C	115 °C	75 °C

The maximum surface temperature T 85...150 °C is based on a maximum ambient temperature of 60 °C.

AMENDMENT 1

to EC-Type Examination Certificate KEMA 01ATEX2263 X

The field coils of the primary heads must be protected by a 160 mA fuse. The breaking capacity of the fuse must be in accordance with the prospective short circuit current of the supply.

All other data remain unchanged.

Test documentation

	<u>dated</u>
1. Description (11 pages)	18.10.2002 and 07.11.2002
2. Drawing List	07.11.2002

Arnhem, 26 November 2002
KEMA Quality B.V.





T. Pijper
Certification Manager

[2024866]

Page 2/2

5.2 PROFIFLUX IFS 5000 F-EEEx certificate

KEMA 



(1) **EC-TYPE EXAMINATION CERTIFICATE**

(2) Equipment or protective system intended for use in potentially explosive atmospheres – Directive 94/9/EC

(3) EC-Type Examination Certificate Number: **KEMA 02ATEX2024 X**

(4) Equipment or protective system: **Electromagnetic flowmeter primary head, types IFS 5000 FI...EEEx and MGS 5000 FI...EEEx**

(5) Manufacturer: **Krohne Altometer**

(6) Address: **Kerkeplaat 12, 3313 LC Dordrecht, The Netherlands**

(7) This equipment or protective system and any acceptable variation thereto is specified in the schedule to this certificate and the documents therein referred to.

(8) KEMA Quality B.V., notified body number 0344 in accordance with Article 9 of the Council Directive 94/9/EC of 23 March 1994, certifies that this equipment or protective system has been found to comply with the Essential Health and Safety Requirements relating to the design and construction of equipment and protective systems intended for use in potentially explosive atmospheres given in Annex II to the Directive.

The examination and test results are recorded in confidential report no. 2017378.

(9) Compliance with the Essential Health and Safety Requirements has been assured by compliance with:

EN 50014 : 1997	EN 50019 : 2000	EN 50020 : 1994
EN 50028 : 1987	EN 50281-1-1 : 1998	

(10) If the sign "X" is placed after the certificate number, it indicates that the equipment or protective system is subject to special conditions for safe use specified in the schedule to this certificate.

(11) This EC-Type Examination Certificate relates only to the design, examination and tests of the specified equipment or protective system in accordance with the Directive 94/9/EC. Further requirements of the Directive apply to the manufacturing process and supply of this equipment or protective system. These are not covered by this certificate.

(12) The marking of the equipment or protective system shall include the following:

 II 2 GD **EEx me Ib BC T6...T3**
T80...180 °C

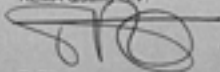
Arnhem, 25 February 2002.
KEMA Quality B.V.

T. Pipker
Certification Manager

* This Certificate may only be reproduced in its entirety and without any change

KEMA Quality B.V.
Ulrechtseweg 310, 6812 AR Arnhem, The Netherlands
P.O. Box 5185, 6802 ED Arnhem, The Netherlands
Telephone +31 26 3 56 20-26, Telex +31 26 3 52 56 00

ACCREDITED BY THE
DUTCH COUNCIL FOR
ACCREDITATION 

Page 1/3

(13)

SCHEDULE

(14)

to EC-Type Examination Certificate KEMA 02ATEX2024 X

(15)

Description

The Electromagnetic flowmeter primary head, types IFS 5000 F/...EEx and MGS 5000 F/...EEx, is used to convert the flow of a conducting fluid into an electrical signal. An associated flowmeter transmitter is used to supply the field coils of the primary head and to convert the measured electrode signal into an output signal.

The field coils of the primary heads are in type of explosion protection encapsulation "m", the electrodes circuit is in type of explosion protection intrinsic safety "i" and the terminal compartment is in type of explosion protection increased safety "e".

The maximum surface temperature T80...180 °C is based on an ambient temperature of 60 °C.

Electrical data

Field coil circuit $U \leq 40$ V (pulsed)
 $I \leq 125$ mA (fuse protected)

The field coils circuit is protected by two 160 mA fuses in the coil excitation circuit of the associated transmitter.

Electrodes circuit in type of explosion protection intrinsic safety EEx ib IIC, only for connection to a certified intrinsically safe circuit, with the following maximum values:

$$\begin{aligned} U_i &= 20 \text{ V} \\ I_i &= 170 \text{ mA} \end{aligned}$$

The effective internal capacitance and inductance are negligibly small.

The signal circuit is operationally grounded.

Installation instructions

For use in potentially explosive atmospheres of flammable gases, fluids or vapours:
The cable entry device shall be in type of explosion protection increased safety "e", suitable for the conditions of use and correctly installed.

For use in the presence of combustible dust:
The cable entry device shall be in type of equipment Category II 2 D, suitable for the conditions of use and correctly installed.

Unused openings shall be closed with suitable certified closing elements.

Routine tests

Each primary head shall withstand a test voltage according to EN 50019 Clause 6 1, of 1500 V during one minute without breakdown between the field coils circuit and the enclosure and between the field coils circuit and the intrinsically safe sensor circuit.

(13) **SCHEDULE**
 (14) **to EC-Type Examination Certificate KEMA 02ATEX2024 X**

(16) **Report**

KEMA No. 2017378.

(17) **Special conditions for safe use**

The relation between temperature class, maximum surface temperature, maximum process temperature and ambient temperature is shown in the following table:

Temperature class	Max. surface temperature	Max. process temperature		
		Ta ≤ 40 °C	Ta ≤ 50 °C	Ta ≤ 60 °C
T6	T 80 °C	65 °C	65 °C	65 °C
T5	T 95 °C	85 °C	85 °C	80 °C
T4	T 130 °C	125 °C	125 °C	120 °C
T3	T 180 °C	180 °C	165 °C	145 °C

Ambient temperature range -40 °C ... +60 °C (meter size DN2.5 - DN15).
 Ambient temperature range -20 °C ... +60 °C (meter size DN25 - DN80).

A heat resistant cable with a continuous operating temperature of at least 120 °C must be used at the conditions as specified below.
 - with Ta ≤ 40 °C and the process temperature ≥ 165 °C, or
 - with Ta ≤ 50 °C and the process temperature ≥ 130 °C, or
 - with Ta ≤ 60 °C and the process temperature ≥ 100 °C.

The breaking capacity of the primary fuse of the signal converter is 300 A (IFC 090, 24 V versions) resp. 1500 A (IFC090, 100-230 V and all IFC090i versions). Therefore, the signal converter may only be connected to a mains supply with a maximum prospective short circuit current of 300 A resp. 1500 A.

(18) **Essential Health and Safety Requirements**

Covered by the standards listed at (9).

(19) **Test documentation**

1. Certificate of Conformity KEMA No. Ex-91.C.9694 X
 Component Certificate KEMA No. Ex-01.E.2036 U
dated
2. Description (14 pages) 16.05.2001, 04.02.2002
 and 13.02.2002
3. Drawings index sheet 13.02.2002

5.3 VARIFLUX IFS 6000 F-EEEx certificate

KEMA 



(1) **EC-TYPE EXAMINATION CERTIFICATE**

(2) Equipment or protective system intended for use in potentially explosive atmospheres – Directive 94/9/EC

(3) EC-Type Examination Certificate Number: **KEMA 02ATEX2038 X**

(4) Equipment or protective system: **Electromagnetic flowmeter primary head, types IFS 6000 F...-EEEx and MGS 6000 F...-EEEx**

(5) Manufacturer: **Krohne Altometer**

(6) Address: **Kerkplaat 12, 3313 LC Dordrecht, The Netherlands**

(7) This equipment or protective system and any acceptable variation thereto is specified in the schedule to this certificate and the documents therein referred to.

(8) KEMA Quality B.V., notified body number 0344 in accordance with Article 9 of the Council Directive 94/9/EC of 23 March 1994, certifies that this equipment or protective system has been found to comply with the Essential Health and Safety Requirements relating to the design and construction of equipment and protective systems intended for use in potentially explosive atmospheres given in Annex II to the Directive.

The examination and test results are recorded in confidential report no. 2018114.

(9) Compliance with the Essential Health and Safety Requirements has been assured by compliance with:

EN 50014 : 1997	EN 50018 : 2000	EN 50019 : 2000
EN 50620 : 1994	EN 50028 : 1987	EN 50281-1-1 : 1998

(10) If the sign "X" is placed after the certificate number, it indicates that the equipment or protective system is subject to special conditions for safe use specified in the schedule to this certificate.

(11) This EC-Type Examination Certificate relates only to the design, examination and tests of the specified equipment or protective system in accordance with the Directive 94/9/EC. Further requirements of the Directive apply to the manufacturing process and supply of this equipment or protective system. These are not covered by this certificate.

(12) The marking of the equipment or protective system shall include the following:

 II 2 GD **EEx me Ib IIC T6...T3** or **EEx de Ib IIC T6...T3**
T80...190 °C

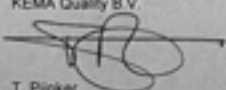
Amhem, 27 February 2002.
KEMA Quality B.V.

T. Pijker
Certification Manager

* This Certificate may only be reproduced in its entirety and without any change

KEMA Quality B.V.
Utrechtseweg 310, 6812 AR Amhem, The Netherlands
P.O. Box 9188, 6802 ED Amhem, The Netherlands
Telephone +31 26 3 86 20-08, Telefax +31 26 3 82 88-00

ACCREDITED BY THE
DUTCH COUNCIL FOR
ACCREDITATION 

Page 1/3

(13)

SCHEDULE

(14)

to EC-Type Examination Certificate KEMA 02ATEX2038 X

(15)

Description

The Electromagnetic flowmeter primary head, types IFS 6000 F/...EEx and MGS 6000 F/...EEx, is used to convert the flow of a conducting fluid into an electrical signal. An associated flowmeter transmitter is used to supply the field coils of the primary head and to convert the measured electrode signal into an output signal.

The field coils of the primary heads are in type of explosion protection encapsulation "m" (sizes DN2,5 - DN15) or flameproof enclosure "d" (sizes DN25 - DN80). The electrodes circuit is in type of explosion protection intrinsic safety EEx ib IIC and the terminal compartment is in type of explosion protection increased safety "e".

The maximum surface temperature T80...190 °C is based on an ambient temperature of 60 °C.

Electrical data

Field coil circuit $U \leq 40$ V (pulsed)
 $I \leq 125$ mA (fuse protected)

The field coils circuit is protected by two 160 mA fuses in the coil excitation circuit of the associated transmitter.

Electrodes circuit in type of explosion protection intrinsic safety EEx ib IIC, only for connection to a certified intrinsically safe circuit, with the following maximum values:

$$\begin{aligned} U_i &= 20 \text{ V} \\ I_i &= 170 \text{ mA} \end{aligned}$$

The effective internal capacitance and inductance are negligibly small.

The signal circuit is operationally grounded.

Installation instructions

For use in potentially explosive atmospheres of flammable gases, fluids or vapours:
The cable entry device shall be in type of explosion protection increased safety "e", suitable for the conditions of use and correctly installed.

For use in the presence of combustible dust:
The cable entry device shall be in type of equipment Category II 2 D, suitable for the conditions of use and correctly installed.

Unused openings shall be closed with suitable certified closing elements.

Routine tests

- Each welded primary head of size DN25 - DN80 shall be submitted to the routine overpressure test according to EN 50018, Clause 16, at a test pressure of 13,5 bar during one minute.

(13) **SCHEDULE**

(14) **to EC-Type Examination Certificate KEMA 02ATEX2038 X**

Routine tests (continued)

- Each primary head shall withstand a test voltage of 1500 V during one minute without breakdown between the field coils circuit and the intrinsically safe sensor circuit. Each primary head of size DN2.5 - DN15 shall additionally withstand a test voltage of 1500 V during one minute without breakdown between the field coils circuit and the enclosure.

(16) **Report**

KEMA No. 2018114.

(17) **Special conditions for safe use**

The relation between temperature class, maximum surface temperature, maximum process temperature and ambient temperature is shown in following table:

Temperature class	Max. surface temperature	Max. process temperature		
		Ta ≤ 40 °C	Ta ≤ 50 °C	Ta ≤ 60 °C
T6	T 80 °C	70 °C	70 °C	70 °C
T5	T 95 °C	85 °C	85 °C	85 °C
T4	T 130 °C	120 °C	120 °C	120 °C
T3	T 190 °C	180 °C	180 °C	165 °C

Ambient temperature range -40 °C ... +60 °C.

A heat resistant cable with a continuous operating temperature of at least 120 °C must be used at the conditions as specified below:

- with Ta ≤ 50 °C and the process temperature ≥ 160 °C, or
- with Ta ≤ 60 °C and the process temperature ≥ 115 °C.

The breaking capacity of the primary fuse of the associated signal converter is 300 A (IFC 090, 24 V versions) resp. 1500 A (IFC090, 100-230 V and all IFC090i versions). Therefore, the signal converter may only be connected to a mains supply with a maximum prospective short circuit current of 300 A resp. 1500 A.

(18) **Essential Health and Safety Requirements**

Covered by the standards listed at (9).

(19) **Test documentation**

1. Certificate of Conformity KEMA No. Ex-95.D.9899 X
KEMA No. Ex-97.D.2886 X
Component Certificate KEMA No. Ex-99.E.8128 U
KEMA No. Ex-01.E.2036 U

dated

2. Description (22 pages) 19.02.2002 and 25.02.2002
3. Drawings index sheet 19.02.2002

<http://www.krohne.com>

Production

KROHNE

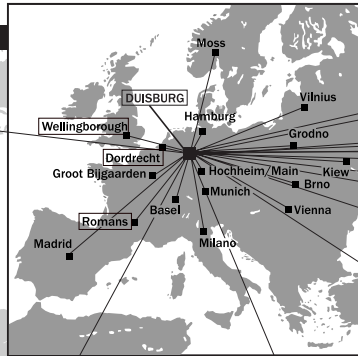

Australia

KROHNE Australia Pty Ltd.
Unit 19 No. 9, Hudson Ave.
Castle Hill 2154, NSW
TEL: +61(0)2-98948711
FAX: +61(0)2-98948555
e-mail: krohne@krohne.com.au

Austria

KROHNE Austria Ges.m.b.H.
Modocenterstraße 14
A-1030 Wien
TEL: +43(0)1/203 45 32
FAX: +43(0)1/203 47 78
e-mail: info@krohne.at

Belgium

KROHNE Belgium N.V.
Brusselstraat 320
B-1702 Groot Bilgaarden
TEL: +32(0)2-4 66 00 10
FAX: +32(0)2-4 66 08 00
e-mail: krohne@krohne.be

Brazil

KROHNE Conaut
Controltes Automaticos Ltda.
Estrada Das Águas Espraiadas, 230 C.P. 56
06835 - 080 EMBU - SP
TEL: +55(0)11-4785-2700
FAX: +55(0)11-4785-2768
e-mail: conaut@conaut.com.br

China

KROHNE Measurement Instruments Co. Ltd.
Room 7E, Yi Dian Mansion
746 Zhao Jia Bang Road
Shanghai 200030
TEL: +86(0)21-64677163
FAX: +86(0)21-64677166
Cellphone: +86(0)139 1885890
e-mail: info@krohne-asia.com

CIS

Kanex KROHNE Engineering AG
Business-Centre Planeta, Office 403
ul. Manistkaja 3
109147 Moscow/Russia
TEL: +7(0)95-9117165
FAX: +7(0)95-9117231
e-mail: krohne@dol.ru

Czech Republic

KROHNE CZ, spol. s r.o.
Soběšická 156
CZ-63800 Brno
TEL: +420 545 532 111
FAX: +420 545 220 093
e-mail: brno@krohne.cz

France

KROHNE S.A.S.
Usine des Ors
BP 98
F-26 103 Romans Cedex
TEL: +33(0)4 75 05 44 00
FAX: +33(0)4 75 05 00 48
e-mail: info@krohne.fr

Germany

KROHNE Messtechnik
GmbH & Co. KG
Ludwig-Krohne-Straße
D-47058 Duisburg
TEL: +49(0)203-301-0
FAX: +49(0)203-301 389
e-mail: krohne@krohne.de

India

KROHNE Marshall Ltd.
A-34/35, M.I.D.C.
Industrial Area, H-Block,
Pimpri Poona 411018
TEL: +91(0)20-744 20 20
FAX: +91(0)20-744 20 40
e-mail: pcu@snl.net

Italy

KROHNE Italia Srl.
Via V. Monti 75
I-20145 Milano
TEL: +39(0)2-4 30 06 61
FAX: +39(0)2-43 00 66 66
e-mail: krohne@krohne.it

Korea

Hankuk KROHNE
2 F, 599-1
Banghwa-2-Dong
Kangseo-Ku
Seoul
TEL: +82(0)2665-85 23-4
FAX: +82(0)2665-85 25
e-mail: flwotech@unitel.co.kr

Netherlands

KROHNE Altometer
Kerkeplaat 12
NL-3313 LC Dordrecht
TEL: +31(0)78-6306300
FAX: +31(0)78-6306390
e-mail: postmaster@krohne-altometer.nl

Norway

KROHNE Nederland B.V.
Kerkeplaat 12
NL-3313 LC Dordrecht
TEL: +31(0)78-6306200
FAX: +31(0)78-6306405
Service Direkt: +31(0)78-6306222
e-mail: info@krohne.nl

Norway

KROHNE Instrumentation A.S.
Ekholtsveien 114
NO-1526 Moss
P.O. Box 2178, NO-1521 Moss
TEL: +47(0)69-264860
FAX: +47(0)69-267333
e-mail: postmaster@krohne.no
Internet: www.krohne.no

South Africa

KROHNE Pty. Ltd.
163 New Road
Halfway House Ext. 13
Midrand
TEL: +27(0)11-315-2685
FAX: +27(0)11-805-0531
e-mail: midrand@krohne.co.za

Spain

I.L. KROHNE Iberia, S.r.L.
Poligono Industrial Nilo
Calle Brasil, n.º 5
E-28806 Alcalá de Henares-Madrid
TEL: +34(0)91-8 83 21 52
FAX: +34(0)91-8 83 48 54
e-mail: krohne@krohne.es

Switzerland

KROHNE AG
Llferstr. 90
CH-4019 Basel
TEL: +41(0)61-638 30 30
FAX: +41(0)61-638 30 40
e-mail: info@krohne.ch

United Kingdom

KROHNE Ltd.
Rutherford Drive
Park Farm Industrial Estate
Wellingsborough,
Northants NN8 6AE, UK
TEL: +44(0)19 33-408 500
FAX: +44(0)19 33-408 501
e-mail: info@krohne.co.uk

USA

KROHNE Inc.
7 Dearborn Road
Peabody, MA 01960
TEL: +1-978 535-6060
FAX: +1-978 535-1720
e-mail: info@krohne.com

Overseas Representatives

Algeria	Japan
Argentina	Jordan
Bulgaria	Kuwait
Cameroon	Morocco
Canada	Mauritius
Chile	Mexico
Columbia	New Zealand
Croatia	Pakistan
Denmark	Poland
Ecuador	Portugal
Egypt	Saudi Arabia
Finland	Senegal
French Antilles	Singapore
Greece	Slovakia
Guinea	Slovenia
Hong Kong	Sweden
Hungary	Taiwan
Indonesia	Thailand
Ivory Coast	Turkey
Iran	Tunisia
Ireland	Venezuela
Israel	Yugoslavia

Other Countries:

KROHNE Messtechnik
GmbH & Co. KG
Ludwig-Krohne-Str.
D-47058 Duisburg
TEL: +49(0)203-301 309
FAX: +49(0)203-301 389
e-mail: export@krohne.de