



OPTIFLEX 2200 C/F Supplementary Instructions

Guided Radar (TDR) Level Transmitter for storage and process applications

Description of FOUNDATION™ fieldbus interface



| | | |
|-------|---|----|
| 1 | Safety instructions | 3 |
| <hr/> | | |
| 1.1 | Scope of the document | 3 |
| 1.2 | Device description | 3 |
| 1.3 | Software history | 3 |
| 1.3.1 | Electronic revision | 3 |
| 1.3.2 | Software revision | 4 |
| 1.4 | Nameplate | 4 |
| 2 | Technical data | 5 |
| <hr/> | | |
| 2.1 | FOUNDATION™ Fieldbus data | 5 |
| 3 | Electrical connections | 6 |
| <hr/> | | |
| 3.1 | Cable types | 6 |
| 3.2 | Shielding and grounding | 7 |
| 3.3 | Electrical connection of FOUNDATION™ fieldbus | 8 |
| 3.4 | Write/Protect and Simulation functions | 9 |
| 3.5 | Topology of FF networks | 11 |
| 4 | Operation | 12 |
| <hr/> | | |
| 4.1 | Settable functions | 12 |
| 4.2 | Description of the FF block system | 13 |
| 4.3 | Used abbreviations | 13 |
| 4.4 | Resource Block (RB) | 14 |
| 4.4.1 | Foundation Fieldbus parameters for Resource Block | 14 |
| 4.4.2 | Manufacturer-specific parameters of the signal converter for Resource Block | 20 |
| 4.5 | Analog Input Block (AI 1...3) | 35 |
| 4.6 | Transducer Block (TB) | 43 |
| 4.6.1 | Transducer "Level" Block | 43 |
| 4.6.2 | Transducer "Display" Block | 51 |
| 4.6.3 | Transducer "Diagnose" Block | 55 |
| 4.7 | Proportional Integral Derivative Block (PID) | 60 |
| 5 | Notes | 74 |
| <hr/> | | |

1.1 Scope of the document

These instructions are supplementary to the standard product documentation of the device. The details depicted therein, in particular the safety information are valid and should be adhered to. The present supplementary instructions provide additional information for the devices when being operated and connected to a FOUNDATION™ fieldbus network.



INFORMATION!

The present supplementary instructions for the device with a FOUNDATION™ fieldbus interface, plus the software with the DD and CFF files are included in our scope of supply, in addition to those items delivered for the standard device.



DANGER!

If the device is for use in potentially explosive atmospheres, refer to the supplementary instructions for ATEX, IECEx or other Ex applications.

1.2 Device description

The TDR level meter is designed to measure the distance, level, mass and volume of liquids, pastes, slurries, granulates and powders. TDR level meters use a probe to guide a signal to the surface of the measured product. The device has a large choice of probes. Thus, it can measure most products in difficult conditions. For more data about the measuring principle, refer to the handbook.

1.3 Software history

1.3.1 Electronic revision

"Electronic revision" agrees with NAMUR NE 53. It is a number used to record the revision status of the hardware and embedded software (firmware) in the device. It gives data on the type of changes made and the effect that changes have on compatibility. The table that follows records the changes for devices that have the FOUNDATION™ fieldbus option.

Data about the electronic revision is shown in menu 1.1.5 ELECTRO.REV.

| Issued [YYYY/MM/DD] | Electronic revision | Hardware revision | | | Document revision |
|------------------------|------------------------|-------------------|-------------|-----------------------------|----------------------|
| | | Converter | Sensor | HMI (LCD display option) | |
| 2014-04-10 | 1.00.00 | 4001858601d | 4000357001v | 4000487601p | R01R02 ① |
| 2014-11-28 | 1.00.00 | 4001858601e | 4000357001v | 4000487601p | R03 ① |

① Supplementary Instructions: Description of FOUNDATION™ fieldbus interface

1.3.2 Software revision

"Firmware revision" agrees with NAMUR NE 53. It is a series of numbers used to record the revision status of embedded software (firmware) in electronic equipment assemblies. It gives data on the type of changes made and the effect that changes have on compatibility. The table that follows records the changes for devices that have the FOUNDATION™ fieldbus option.

Data about software revisions is shown in menu 1.1.0 IDENT. For more data refer to the "Operation" chapter in the handbook. If it is not possible to refer to the device menu, record the serial number of the device (given on the device nameplate) and speak to the supplier.

| Issued [YYYY/MM/DD] | Firmware revision | PACTware DTM | Document revision |
|---------------------|-------------------|--------------|-------------------|
| 2014-04-10 | 2.42.0.46 | 1.0.1 | R01R02 ① |
| 2015-08-27 | 2.42.48 | 1.0.3 | R03 ① |

① Supplementary Instructions: Description of FOUNDATION™ fieldbus interface

1.4 Nameplate

Signal converter housing (compact and remote (field) versions)

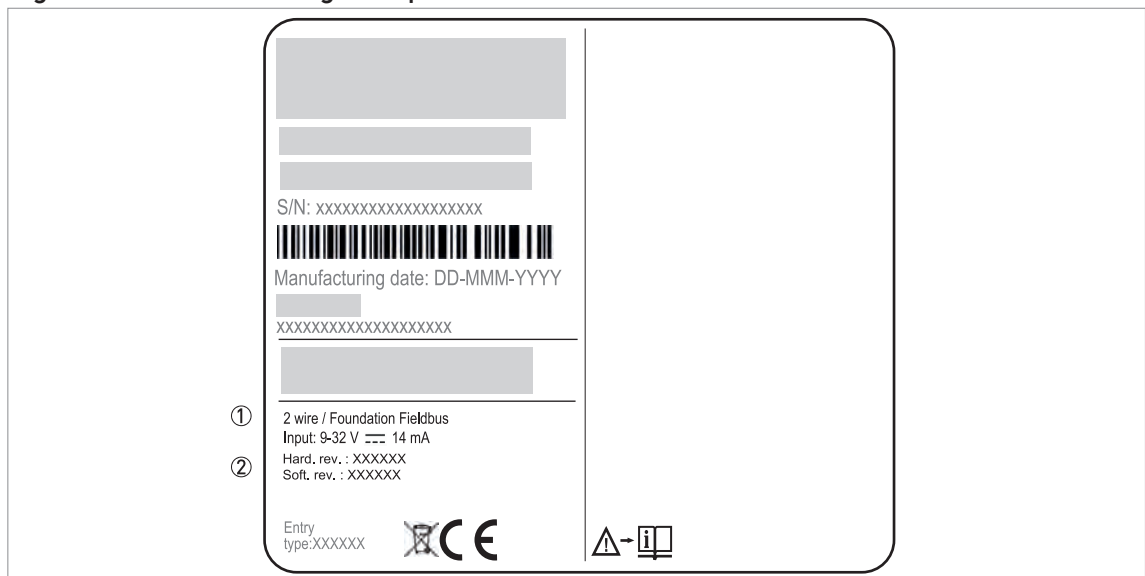

Figure 1-1: Nameplate for a device with the FOUNDATION™ fieldbus option

- ① Output or communication protocol option
Input voltage range / Basic current
- ② Hardware and software versions. These version numbers agree with NAMUR NE 53.



INFORMATION!

If you have the remote (field) version of the device, there is no FOUNDATION™ fieldbus data on the nameplate attached to the probe housing.

2.1 FOUNDATION™ Fieldbus data

Description

| | |
|------------------------|---|
| Type | 2-wire loop-powered level transmitter; Time Domain Reflectometry (TDR) |
| Physical layer | FOUNDATION™ fieldbus protocol that agrees with IEC 61158-2 and FISCO model; galvanically isolated |
| Communication standard | H1 |
| ITK version | 6.1 |
| Link Active Scheduler | Supported |

Data blocks

| | |
|--------------------|--|
| Function blocks | 1 x Resource Block (RB) |
| | 1 x Level Transducer Block |
| | 1 x Display Transducer Block |
| | 1 x Diagnose Transducer Block |
| | 3 x Analog Input Block (AI) |
| | 1 x Proportional Integral Derivate Block (PID) |
| Execution time | Analog Input Block: 30 ms |
| | Proportional Integral Derivate Block: 40 ms |
| Minimum cycle time | 250 ms |

Electrical connections

| | |
|-----------------------|--|
| Device power supply | Not intrinsically safe: 9...32 VDC |
| | Intrinsically safe: 9...24 VDC |
| Basic current | 14 mA |
| Maximum error current | 20.5 mA (= basic current + error current = 14 mA + 6.5 mA) |
| Error current FDE | Typically 6.5 mA (FDE =Fault Disconnection Electronic) |
| Polarity sensitivity | No |
| Minimum cycle time | 250 ms |

Input and output

| | |
|-------------|--|
| Output data | Level, distance, ullage conversion, level conversion |
| Input data | None |

3.1 Cable types

Electrical cable specifications agree with International Standard IEC 61158-2. Shielded cables prevent malfunctions and give protection from electromagnetic interference. We recommend that you follow these specifications to get good system performance.

| | | | | |
|-------------------------------|-------------------------------------|--|---|--|
| Core cross-section | 0.8 mm ² or AWG 18 | 0.32 mm ² or AWG 22 | 0.13 mm ² or AWG 26 | 1.25 mm ² or AWG 16 |
| Cable type | A | B | C | D |
| | twisted pair, individually shielded | individual or multiple twisted pairs with overall shield | multiple twisted pairs, without shielding | multiple non-twisted cables, without shielding |
| Max. length incl. branch line | 1900 m / 6200 ft | 1200 m / 3900 ft | 400 m / 1300 ft | 200 m / 650 ft |

In non-hazardous locations, a maximum of 32 field devices can be connected to the network. For more data, refer to the table that follows.

| Number of devices on the bus segment | Electrical cable length on the spur | | | |
|--------------------------------------|-------------------------------------|---------------|---------------|---------------|
| | 1 device | 2 devices | 3 devices | 4 devices |
| 25...32 | 1 m / 3.3 ft | 1 m / 3.3 ft | 1 m / 3.3 ft | 1 m / 3.3 ft |
| 19...24 | 30 m / 100 ft | 1 m / 3.3 ft | 1 m / 3.3 ft | 1 m / 3.3 ft |
| 15...18 | 60 m / 200 ft | 30 m / 100 ft | 1 m / 3.3 ft | 1 m / 3.3 ft |
| 13...14 | 90 m / 300 ft | 60 m / 200 ft | 30 m / 100 ft | 1 m / 3.3 ft |
| 1..12 | 120 m / 400 ft | 90 m / 300 ft | 60 m / 200 ft | 30 m / 100 ft |



INFORMATION!

Electrical cable length decreases if the number of devices on the branch line increases.

A terminator must be connected at the two ends of each bus segment.

3.2 Shielding and grounding

- For optimum electromagnetic compatibility of systems it is extremely important that the system components, and particularly the bus cables connecting the components, are shielded and that such shields - if possible - form an unbroken cover.
- Hence, it follows that, for use in non-hazardous duty systems, the cable shield should be grounded as often as possible.
- In Ex systems an adequate equipotential bonding in the hazardous and non-hazardous location along the entire Fieldbus installation is strongly recommended. Multiple grounding of the shield is of advantage.
- We recommend that you connect the two ends of the shield wire insulation (between the device and the distributed control system (DCS)) to ground (PE), as given in the fieldbus specifications. If the ground (zero potential) for the device and the control system are different, connect the supplied capacitor to the grounding terminal on the device housing. For more data, refer to the procedure that follows.
- NAMUR NE 21 compliance is given, provided the above recommended cable types are used.



INFORMATION!

The use of twisted and shielded cables is strongly recommended, otherwise EMC protection of the signal converter cannot be assured.

Procedure: How to connect the shield wire insulation if zero potential (PE) for the device and the control system are different

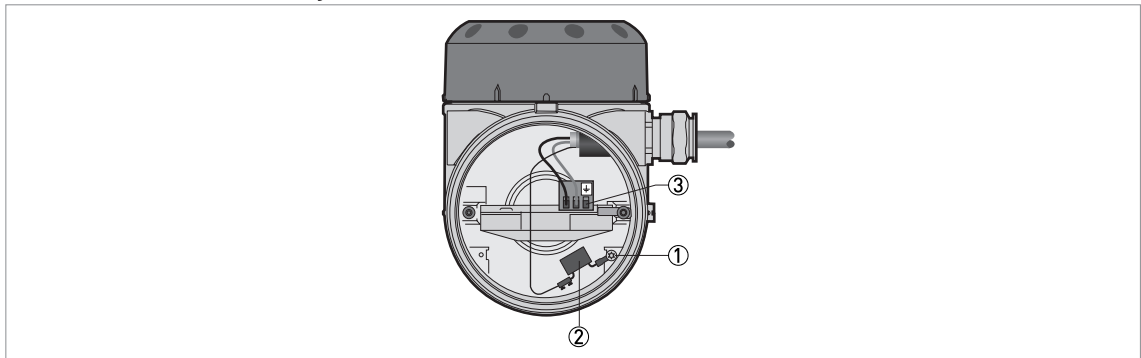

Figure 3-1: Procedure: How to connect the shield wire insulation if zero potential (PE) for the device and the control system are different

- ① Grounding terminal (housing)
- ② Capacitor (supplied in a plastic transparent bag with the device)
- ③ Grounding terminal (converter electronics) – DO NOT USE



CAUTION!

Use this procedure if you cannot connect the two ends of the shield wire insulation to ground.

Equipment needed

- Device
- Handbook
- Capacitor (supplied in a transparent plastic bag with the device)
- T10 Torx wrench (not supplied)
- Small slotted-tip screwdriver (not supplied)



- Remove the terminal compartment cover.
- Remove the capacitor from the transparent plastic bag.
- Connect the capacitor to the grounding terminal ①. Tighten the terminal screw with a T10 Torx wrench.
- Use a small slotted-tip screwdriver to connect one end of the shield wire insulation to the capacitor.
- ➡ End of the procedure.

3.3 Electrical connection of FOUNDATION™ fieldbus



INFORMATION!

The FOUNDATION™ fieldbus interface of the signal converter will operate only if the power supply is connected/available. The device terminal is not sensitive to electrical polarity. The device can only be connected to a spur. Do a check of the device nameplate to make sure that the device has the FOUNDATION™ fieldbus option. For more data, refer to Nameplate on page 4.

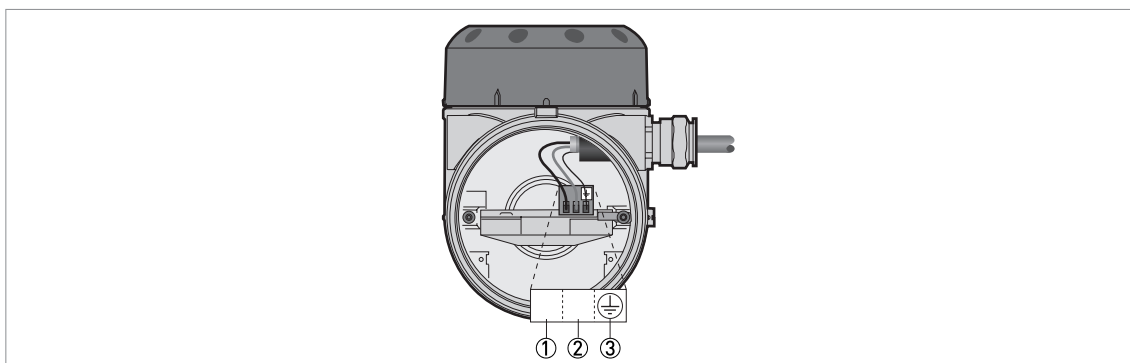

Figure 3-2: Electrical installation: terminals

- ① Power supply / communication terminal
- ② Power supply / communication terminal
- ③ Grounding terminal (converter electronics)

3.4 Write/Protect and Simulation functions

The "Write/Protect" function prevents changes to device settings. The "Simulation" function lets the user test the device and the fieldbus network.



INFORMATION!

The manufacturer sets the "Write/Protect" and the "Simulation" DIP switches to the OFF position in the factory.

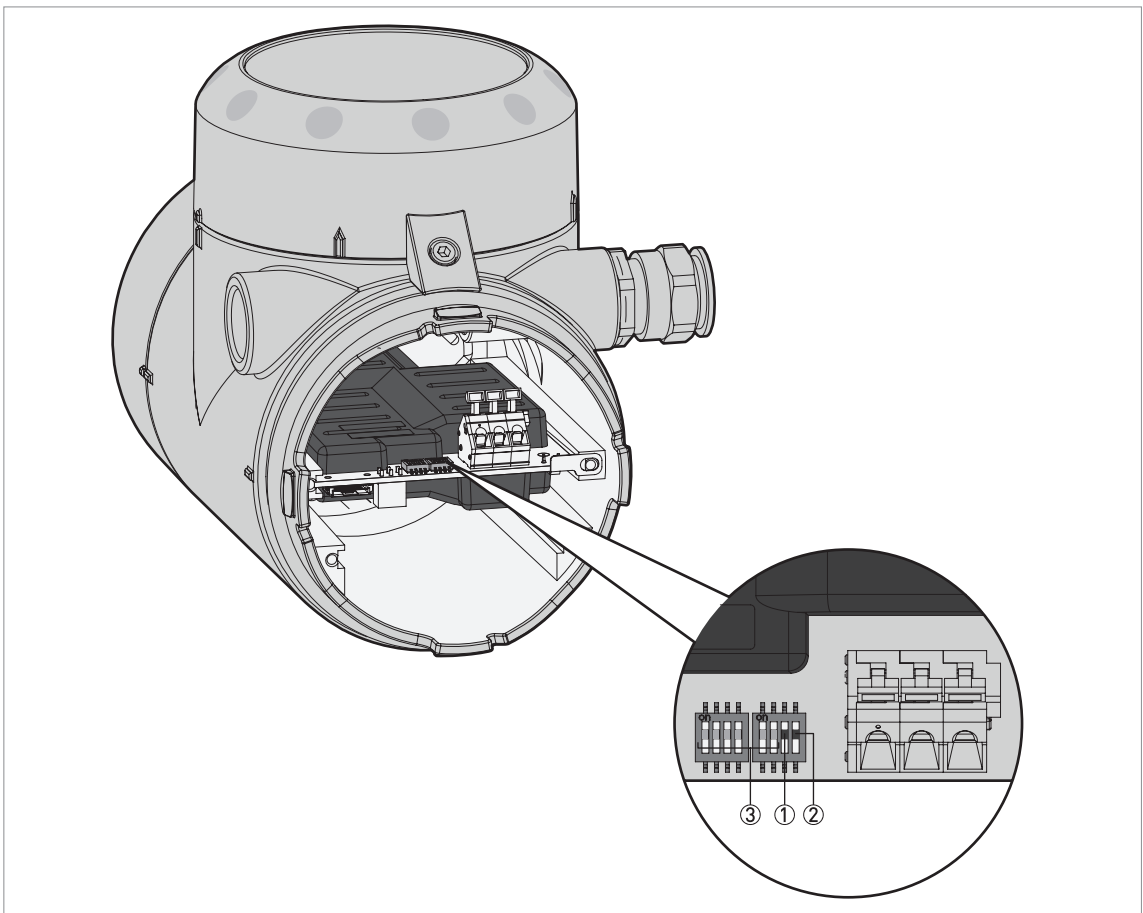

Figure 3-3: DIP switches for "Write/Protect" and "Simulation" functions

- ① "Write/Protect" DIP switch
OFF: Device settings can be changed
ON: Device settings cannot be changed
- ② "Simulation" DIP switch
OFF: "NORMAL" mode
ON: "SIMULATION" mode
- ③ 6 × DIP switches: not used

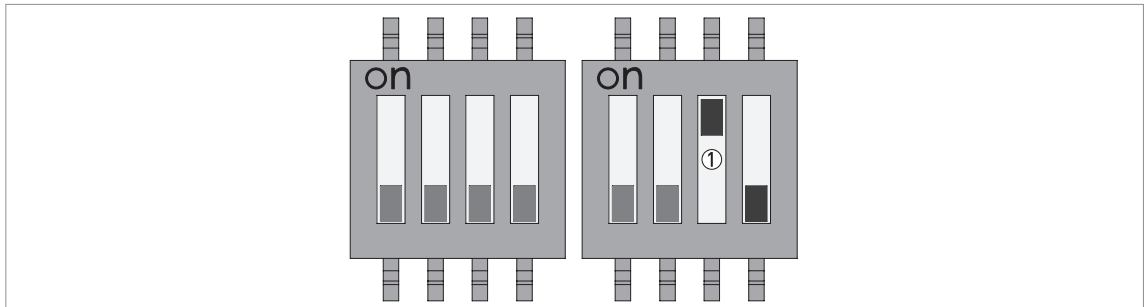

Figure 3-4: How to prevent changes to the device settings

- ① "Write/Protect" DIP switch: set to the ON position (device settings cannot be changed)



How to prevent changes to the device settings

- Open the terminal compartment cover. For the procedure, refer to "Electrical connections" in the handbook.
 - Use the tip of a pencil or small screwdriver to move the "Write/Protect" DIP switch to the ON position.
 - Close the terminal compartment cover. For the procedure, refer to "Electrical connections" in the handbook.
- ⊖ You cannot use the LCD display or the FOUNDATION™ fieldbus interface to change the device settings. If it is necessary to change the device settings, move the "Write/Protect" DIP switch to the OFF position.

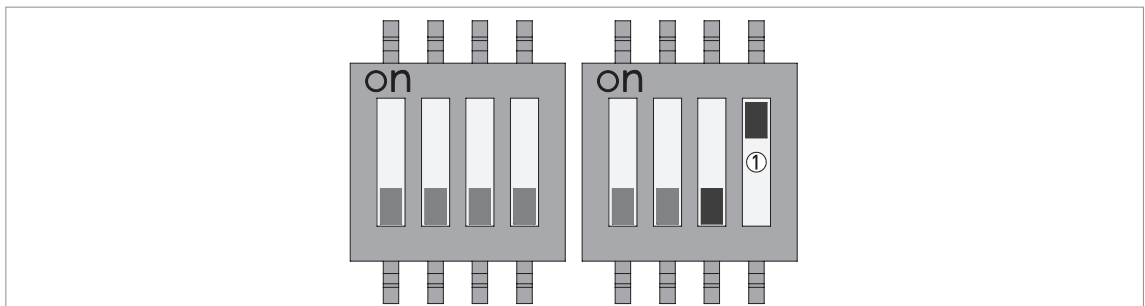

Figure 3-5: How to test the device and the fieldbus network (SIMULATION mode)

- ① "Simulation" DIP switch: set to the ON position (SIMULATION mode)



How to test the device and the fieldbus network ("SIMULATION" mode)

- Open the terminal compartment cover. For the procedure, refer to "Electrical connections" in the handbook.
 - Use the tip of a pencil or small screwdriver to move the "Simulation" DIP switch to the ON position.
 - Close the terminal compartment cover. For the procedure, refer to "Electrical connections" in the handbook.
- ⊖ If the DIP switch is set to the ON position, the device is in "SIMULATION" mode. Use the "SIMULATION" mode to test the device and the fieldbus network. Set the DIP switch back to the OFF position to operate the device in "NORMAL" mode in the fieldbus network.

3.5 Topology of FF networks

An example of mixed topology of FF networks is shown in the following example.

Connection is best made via short branch cables and T connectors. This connection type makes it possible to connect and disconnect the devices without interrupting the bus or the communication.

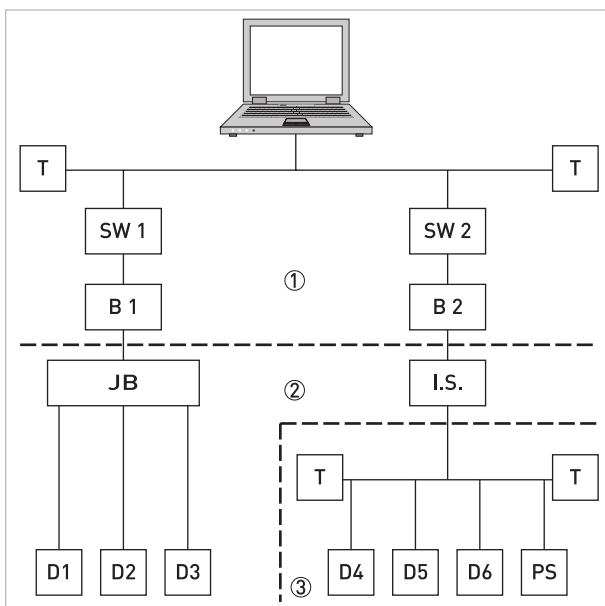

- ① HSE network
- ② H1 bus
- ③ Intrinsically safe, explosive area
- B1+B2 Bridge = coupling element for H1 bus and HSE network
- D1-D3 Device = field devices, own power supply, for non potentially explosive areas
- D4-D6 Intrinsically safe devices, external power supply, for potentially explosive areas
- I.S. Intrinsically safe barrier
- JB Junction box for field devices
- PS Power supply
- Switch = connection of multiple HSE sub networks
- T Terminator

4.1 Settable functions

- The following table gives only the menus, functions and parameters which are different between the standard signal converter and the FOUNDATION fieldbus signal converter.
- For the electrical connections and a complete description of all functions, refer to the handbook.



INFORMATION!

If you change device-specific parameters, we recommend that you set device and system length units to millimetres (mm). New settings are rejected if system length units and device length units are different.

1.0.0 Information (Info.) menu

| No. | Displayed text | Description and settings |
|-----|----------------|--------------------------|
|-----|----------------|--------------------------|

1.0.0 IDENT.

| | | |
|-------|--------------|--|
| 1.1.5 | ELECTRO.REV. | Electronic revision. This menu item is specific to fieldbus devices and gives hardware version data. The electronic revision agrees with the NAMUR NE 53 recommendation. Read only. |
|-------|--------------|--|

1.2.0 OUTPUT I

| | | |
|-------|-------|--|
| 1.2.x | XXXXX | This sub-menu is not available for FOUNDATION™ fieldbus devices. |
|-------|-------|--|

2.0.0 Supervisor menu

| No. | Displayed text | Description and settings |
|-----|----------------|--------------------------|
|-----|----------------|--------------------------|

2.1.0 COMMISSION.

| | | |
|-------|------------|---|
| 2.1.1 | PARAMETERS | This procedure is not available for FOUNDATION™ fieldbus devices. |
|-------|------------|---|

2.2.0 TEST

| | | |
|-------|------------|---|
| 2.2.1 | SET OUTPUT | This menu item is not available for FOUNDATION™ fieldbus devices. |
|-------|------------|---|

2.3.0 BASIC PARAM.

| | | |
|--------|----------|---|
| 2.3.10 | TAG NAME | This menu item is not available for FOUNDATION™ fieldbus devices. If the customer gives a tag name (max. 16 characters), the manufacturer enters this data in the device software at the factory. The tag name is shown on the top line of the optional LCD display screen. The tag name is also given on the device nameplate and on an optional stainless steel plate option attached to the housing. An FF TAG is available. The FF TAG has a maximum of 32 characters. The manufacturer uses 16 characters (this data is also shown in the DeviceID or in the "S/N" field on the device nameplate). The device supervisor can use a maximum of 16 characters. |
|--------|----------|---|

2.4.0 OUTPUT I

| | | |
|-------|-------|--|
| 2.4.x | XXXXX | This sub-menu is not available for FOUNDATION™ fieldbus devices. |
|-------|-------|--|

2.6.0 COMMUNICAT.

| | | |
|-------|-------|--|
| 2.6.x | XXXXX | This sub-menu is not available for FOUNDATION™ fieldbus devices. |
|-------|-------|--|

4.2 Description of the FF block system

The Foundation Fieldbus is a Local Area Network (LAN) for connecting field devices like sensors and actuators. One of the main benefits of Foundation Fieldbus is line saving in comparison to the traditional 4...20 mA technology.

The different device functions are implemented in a block-based scheme within a user application. In this block scheme, a distinction is made between the Resource Block, Transducer Block and Function Block.

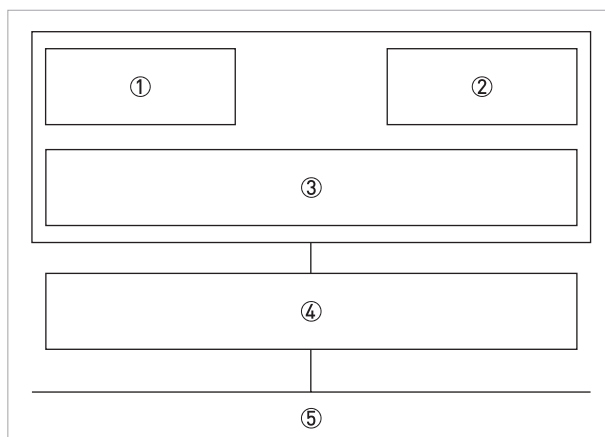

- ① Resource Block (RB)
- ② Transducer Block (TB)
- ③ Function Block (FB)
- ④ Device FF communication
- ⑤ Foundation Fieldbus

4.3 Used abbreviations

| | | | |
|-----|--------------------------------------|------|----------------------------------|
| AI | Analogue Input Block | BLK | Block mode |
| PID | Proportional Integral Derivate Block | MAN | Manual mode |
| RB | Resource Block | Auto | Automatic mode |
| TB | Transducer Block | OOS | Out Of Service mode |
| R | Read | OD | Object Directory |
| W | Write | IV | Initial Value |
| RW | Read and Write | PV | Process Value (factory settings) |
| SP | Set Point | | |

4.4 Resource Block (RB)

The following tables list the Resource Block parameters in alphabetical order.

It describes characteristics of the Fieldbus device (e.g. device name, serial number, etc.) and is not included in the functional tasks of the signal converter for FF.

The following tables contain short parameter description, factory settings (Initial Value (IV)) and possible settings.

4.4.1 Foundation Fieldbus parameters for Resource Block

| Parameter DD name | Access | Description and settings | Initial Value |
|---------------------------------|--------|--|----------------------|
| ALERT_KEY Alert Key | RW | The identification number of the plant unit. This information may be used in the host for sorting alarms, etc. Setting: 1...255 | 0 |
| BLOCK_ERR Block Error | R | This parameter reflects the error status associated with the hardware or software components associated with a block. It is a bit string, so that multiple errors may be shown. Setting: <ul style="list-style-type: none"> • Other: Non-specific error active • Block Configuration: Error detected in block configuration • Link Configuration: Error detected in link configuration • Simulation Active: Simulation enabled in this block • Local Override: Output tracking of faultstate active • Device Fault State: Device faultstate set • Device Maintenance: Device needs maintenance soon • Input Failure: Process variable has bad status • Output Failure: Failure detected in output hardware • Memory Failure: Memory error detected • Lost Static Data: Static parameters cannot be recovered • Lost NV Data: Non-volatile parameters cannot be recovered • Readback Check: Failure detected in READBACK • Maintenance Needed: Device NEEDS maintenance NOW • Power Up: Recovery from power failure • Out Of Service: Block actual mode is out of service | OOS (Out of Service) |
| MODE_BLK Block Mode | | The actual, target, permitted and normal modes of the block. | - |
| TARGET Target | RW | This is the mode requested by the operator. Only one mode from those allowed by the permitted mode parameter may be requested. Setting: Auto / OOS | OOS |
| ACTUAL Actual | R | This is the current mode of the block, which may differ from the target based on operating conditions. Its value is calculated as part of block execution. Setting: Auto / OOS | OOS |
| PERMITTED Permitted | RW | Defines the modes which are allowed for an instance of the block. The permitted mode is configured based on application requirement. Setting: Auto / OOS | Auto OOS |

| Parameter DD name | Access | Description and settings | Initial Value |
|----------------------------------|--------|--|--------------------|
| NORMAL Normal | RW | This is the mode which the block should be set to during normal operating conditions. Setting: Auto / OOS | Auto |
| ST_REV Static Revision | R | The revision level of the static data associated with the function block. The revision value will be incremented each time a static parameter value in the block is changed. Setting: 0...65535 | 0 (=uninitialized) |
| STRATEGY Strategy | RW | The strategy field can be used to identify grouping of blocks. This data is not checked or processed by the block. Setting: 0...65535 | 0 |
| TAG_DESC Tag Description | R/W | The user description of the intended application of the block. Setting: ≤32 digits | blanks |
| ACK_OPTION Acknowledge Option | RW | Selection of whether alarms associated with the function block will be automatically acknowledged. Setting: Disc Alm Auto Ack / Blk Alm Auto Ack / Fail Alm Auto Ack / Off Spec Alm Auto Ack / Maint Alm Auto Ack / Check Alm Auto Ack | Uninitialized |
| ALARM_SUM Alarm Summary | R | The current alert status, unacknowledged states, unreported states and disabled states of the alarms associated with the function block. | - |
| CURRENT Current | R | The active status of each alarm. Setting: Discrete Alarm / Block Alarm / Fail Alarm / Off Spec Alarm / Maintenance Alarm / Check Alarm | Uninitialized |
| UNACKNOWLEDGED Unacknowledged | R | The unacknowledged state of each alarm. Setting: Disc Alm Unack / Block Alm Unack / Fail Alm Unack / Off Spec Alm Unack / Maint Alm Unack / Check Alm Unack | Uninitialized |
| UNREPORTED Unreported | R | The unreported status of each alarm. Setting: Disc Alm Unrep / Block Alm Unrep / Fail Alm Unrep / Off Spec Alm Unrep / Maint Alm Unrep / Check Alm Unrep | Uninitialized |
| DISABLED Disabled | RW | The disabled state of each alarm. Setting: Disc Alm Disabled / Block Alm Disabled / Fail Alm Disabled / Off Spec Alm Disabled / Maint Alm Disabled / Check Alm Disabled | Uninitialized |
| BLOCK_ALM Block Alarm | | The block alarm is used for all configuration, hardware, connection failure or system problems in the block. The cause of the alert is entered in the subcode field. The first alert to become active will set the "Active" status in the "Status" attribute. As soon as the "Unreported" status is cleared by the alert reporting task, another block alert may be reported without clearing the "Active" status, if the subcode has changed. | - |

| Parameter DD name | Access | Description and settings | Initial Value |
|----------------------------------|--------|---|---------------------------------|
| UNACKNOWLEDGED Unacknowledged | RW | A discrete enumeration which is set to "Unacknowledged" when an alarm occurs, and set to "Acknowledged" by a write from a human interface device or other entity which can acknowledge that the alarm/event has been noticed. Setting: Uninitialized / Acknowledged / Unacknowledged | Uninitialized |
| ALARM_STATE Alarm State | R | A discrete enumeration which gives an indication of whether the alert is active and whether it has been reported. Setting: Uninitialized / Clear - reported / Clear - not reported / Active - reported / Active - not reported | Uninitialized |
| TIME_STAMP Time Stamp | R | The time when evaluation of the block was started and a change in alarm/event state was detected that is unreported. The time stamp value will be maintained constant until alert confirmation has been received - even if another change of state occurs. Setting: MM / DD / YY (Month / Day / Year) HH:MM:SS (Hour:Minute:Second) | Uninitialized |
| SUB_CODE Subcode | R | An enumeration specifying the cause of the alert to be reported. Setting: Other / Block Configuration / Link Configuration / Simulation Active / Local Override / Device Fault State / Device Maintenance / Input Failure / Output Failure / Memory Failure / Lost Static Data / Lost NV Data / Readback Check / Maintenance Needed / Power Up / Out Of Service | Other |
| VALUE Value | R | The value of the associated parameter at the time the alert was detected. Setting: 0...255 | 0 |
| CLR_FSTATE Clear Fault State | R/W | Writing a "Clear" to this parameter will clear the device fault state if the field condition, if any, has cleared. Setting: Uninitialized / Off / Clear | Off |
| CONFIRM_TIME Confirm Time | RW | The minimum time between retries of alert reports. Setting: 0...4294967295 in [1/32 ms] | 640000 |
| CYCLE_SEL Cycle Selection | RW | Used to select the block execution method for this resource. Setting: Scheduled / Block execution | Uninitialized |
| CYCLE_TYPE Cycle Type | R | Identifies the block execution methods available for this resource. Setting: Scheduled / Block execution | Scheduled Block execution |
| DD_RESOURCE DD Resource | R | String identifying the tag of the resource which contains the Device Description for this resource. Setting: ≤ 32 digits | blanks |
| DD_REV DD Revision | R | Revision of the DD associated with the resource - used by an interface device to locate the DD file for the resource. Setting: Dependent on device version. | Dependent on device version. |

| Parameter DD name | Access | Description and settings | Initial Value |
|---|--------|---|---|
| DEV_REV Device Revision | R | Manufacturer revision number associated with the resource - used by an interface device to locate the DD file for the resource. | Dependent on device version. |
| | | Setting: Dependent on device version. | |
| DEV_TYPE Device Type | R | Manufacturer's model number associated with the resource - used by interface devices to locate the DD file for the resource. | OPTIFLEX2200 |
| | | Setting: OPTIFLEX2200 | |
| FAULT_STATE Fault State | R | Condition set by loss of communication to an output block, failure promoted to an output block or a physical contact. When fault state condition is set, then output function blocks will perform their "FSTATE" actions. | Clear |
| | | Setting: Uninitialized / Clear / Active | |
| FEATURES Features | R | Used to shows supported resource block options. | Reports Soft W Lock MVC Report Distribution supported MVC Publishing/Subscribing supported Multi-bit Alarm (Bit-Alarm) Support |
| | | Setting: Reports / Faultstate / Soft W Lock / MVC Report Distribution supported / MVC Publishing/Subscribing supported / Multi-bit Alarm (Bit-Alarm) Support | |
| FEATURES_SEL Features Selection | R/W | Used to select resource block options. | Reports Soft W Lock |
| | | Setting: Reports / Faultstate / Soft W Lock / MVC Report Distribution supported / MVC Publishing/Subscribing supported / Multi-bit Alarm (Bit-Alarm) Support | |
| FREE_SPACE Free Space | R | Percent of the memory available for further configuration. Zero in a preconfigured device. | 0.0 |
| | | Setting: 0.0...100.0 | |
| FREE_TIME Free Time | R | Percent of the block processing time that is free to process additional blocks. | 0.0 |
| | | Setting: 0.0...100.0 | |
| GRANT_DENY Grant Deny | R/W | Options for controlling access of host computers and local control panels to operating, tuning and alarm parameters of the block. | - |
| GRANT Grant | RW | Depending on the philosophy of the plant, the operator or a higher level device (HLD) or a local operator's panel (LOP) in the case of "Local", may turn on an item of the "Grant" attribute - Program, Tune, Alarm or Local. | Uninitialized |
| | | Setting: Program / Tune / Alarm / Local / Operate | |
| DENY Deny | RW | The Denied attribute is limited for use by a monitoring application in an interface device and may not be changed by an operator. | Uninitialized |
| | | Setting: Program denied / Tune denied / Alarm denied / Local denied / Operate denied | |
| HARD_TYPES Hardware Types | R | The types of hardware available as channel numbers. | Scalar input |

| Parameter DD name | Access | Description and settings | Initial Value |
|--|--------|---|---------------|
| ITK_VER ITK Version (Interoperability Test Kit) | R | Major revision number of the interoperability test case used to register this device. | 6.1 |
| LIM_NOTIFY Limit Notify | R/W | Maximum number of unconfirmed alert notify messages allowed. Setting: 0...255 | 20 |
| MANUFAC_ID Manufacturer ID | R | Manufacturer identification number - used by an interface device to locate the DD file for the resource. Setting: KROHNE | KROHNE |
| MAX_NOTIFY Maximum Notify | R | Maximum number of unconfirmed alert notify messages possible. Setting: 0...255 | 20 |
| MEMORY_SIZE Memory Size | R | Available configuration memory in the empty resource. To be checked before attempting a download. | 0 |
| MIN_CYCLE_T Minimum Cycle Time | R | Time duration of the shortest cycle interval of which the resource is capable (in [1/32 ms]). | 6400 |
| NV_CYCLE_T Nonvolatile Cycle Time | R | Interval between writing copies of NV parameters to non-volatile memory. Zero means never (in [1/32 ms]). | 256000 |
| RESTART Restart | RW | Allows a manual restart to be initiated. Several degrees of restart are possible. They are 1: Run, 2: Restart resource, 3: Restart with defaults and 4: Restart processor. Setting: Uninitialized / Run / Resource / Defaults / Processor | Run |
| RS_STATE Resource State | R | State of the function block application state machine. Setting: Uninitialized / StartRestart / Initialization / Online Linking / Online / Standby / Failure | Standby |
| SET_FSTATE Set Fault State | RW | Allows the fault state condition to be manually initiated by selecting "SET". Setting: Uninitialized / OFF / SET | OFF |
| SHED_RCAS Shed Remote Cascade | R/W | Time duration at which to give up on computer writes to function block RCAS locations. Setting: 0...4294967295 in [1/32 ms] | 640000 |
| SHED_ROUT Shed Remote Out | RW | Time duration at which to give up on computer writes to function block ROUT locations. Setting: 0...4294967295 in [1/32 ms] | 640000 |
| TEST_RW Test R Write | | Read/write test parameter - used only for conformance testing. Note: Subelements "1..15" have no function! | - |
| UPDATE_EVT Update Event | | This alert is generated by any change to the static data. | - |

| Parameter DD name | Access | Description and settings | Initial Value |
|------------------------------------|--------|--|---------------|
| UNACKNOWLEDGED Unacknowledged | RW | A discrete enumeration which is set to "Unacknowledged" when an update occurs, and set to "Acknowledged" by a write from a human interface device or other entity which can acknowledge that the alarm/event has been noticed. Setting: Uninitialized / Acknowledged / Unacknowledged | Uninitialized |
| UPDATE_STATE Update State | R | A discrete enumeration which gives an indication of whether the alert has been reported. Setting: Uninitialized / Reported / Not reported | Uninitialized |
| TIME_STAMP Time Stamp | R | The time when evaluation of the block was started and a change in alarm/event state was detected that is unreported. The time stamp value will be maintained constant until alert confirmation has been received - even if another change of state occurs. Setting: MM / DD / YY (Month / Day / Year) HH:MM:SS (Hour:Minute:Second) | Uninitialized |
| STATIC_REVISION Static Revision | R | The static revision of the block whose static parameter was changed and is being reported. It is possible for the present value of static revision to be greater than this because static can be changed at any time. Setting: 0...65535 | 0 |
| RELATIVE_INDEX Relative Index | R | The OD index of the static parameter whose change caused this alert, minus the FB starting index. If the update event was caused by a write to multiple parameters at the same time, then this attribute will be zero. Setting: 0...65535 | 0 |
| WRITE_ALM Write Alarm | | This alert is generated if the write lock parameter is cleared. | - |
| UNACKNOWLEDGED Unacknowledged | RW | A discrete enumeration which is set to "Unacknowledged" when an alarm occurs, and set to "Acknowledged" by a write from a human interface device or other entity which can acknowledge that the alarm/event has been noticed. Setting: Uninitialized / Acknowledged / Unacknowledged | Uninitialized |
| ALARM_STATE Alarm State | R | A discrete enumeration which gives an indication of whether the alert is active and whether it has been reported. Setting: Uninitialized / Clear - reported / Clear - not reported / Active - reported / Active - not reported | Uninitialized |
| TIME_STAMP Time Stamp | R | The time when evaluation of the block was started and a change in alarm/event state was detected that is unreported. The time stamp value will be maintained constant until alert confirmation has been received - even if another change of state occurs. Setting: MM / DD / YY (Month / Day / Year) HH:MM:SS (Hour:Minute:Second) | Uninitialized |

| Parameter DD name | Access | Description and settings | Initial Value |
|-----------------------------|--------|---|---------------|
| SUB_CODE Subcode | R | An enumeration specifying the cause of the alert to be reported. Setting: Other / Block Configuration / Link Configuration / Simulation Active / Local Override / Device Fault State / Device Maintenance / Input Failure / Output Failure / Memory Failure / Lost Static Data / Lost NV Data / Readback Check / Maintenance Needed / Power Up / Out Of Service | Other |
| VALUE Discrete Value | R | The value of the associated parameter at the time the alert was detected. Setting: Discrete State 0...16 | State 0 |
| WRITE_LOCK Write Lock | RW | If set, no writes from anywhere are allowed, except to clear WRITE_LOCK. Block inputs will continue to be updated. Setting: Uninitialized / Not locked / Locked | Not locked |
| WRITE_PRI Write Priority | R | Priority of the alarm generated by clearing the write lock. Setting: 0...15 | 0 |

4.4.2 Manufacturer-specific parameters of the signal converter for Resource Block

| Parameter DD name | Access | Description and settings | Initial Value |
|--|--------|--|---|
| DEV_DESCRIPTION Device Description | | Describes some characteristics of the device | - |
| ELECTRONIC_REV electronic revision | R | Electronic Revision of the device | Current electronic revision |
| FW_CONV_VER FW sensor | R | Firmware version of the converter | Current firmware version of the converter |
| FW_SENSOR_VER FW sensor | R | Sensor version | Current sensor version |
| FW_HMI_VER FW HMI | R | Version of the human-machine-interface firmware part | Current version of HMI |
| PRODUCTION_DATE Production date | R | Production date | Current date of production |
| FF_BOARD_INFO FF Circuit Board Info | | FF board information | |
| IDENT_NUMBER identnumber | R | Ident number | Current ident number |
| SOFTWARE_VER FF software version | R | FF software version | Current version |

| Parameter DD name | Access | Description and settings | Initial Value |
|--|--------|--|---------------|
| FD_CHECK_ACTIVE Check Active | R | <p>This parameter reflects the error conditions that are being detected as active as selected for this category. It is a bit string, so that multiple conditions may be shown.</p> <p>Setting:</p> <ul style="list-style-type: none"> • (00) Check Function • (01) Cond01 • (02) Cond02 • (03) Cond03 • (04) Cond04 • (05) Cond05 • (06) Snapshot invalid • (07) Audio Signal Offset outside Range • (08) Reference Position outside Range • (09) Pulse Flange Lost • (10) No Probe detected • (11) Reference Lost Error • (12) Oscillator Frequency failure • (13) Temperature Above +75°C • (14) Temperature Below -35°C • (15) Overfill Warning • (16) Level Lost warning • (17) Temperature out of range (warning) • (18) Local operation • (19) Overfill Error • (20) Level lost error • (21) Temperature out of range Error • (22) Converter Voltage Error • (23) Converter ROM Error • (24) Converter RAM Error • (25) Converter EEPROM Error • (26) Sensor not compatible • (27) Internal Communication Error • (28) Sensor Voltage Error • (29) Sensor ROM Error • (30) Sensor RAM Error • (31) Sensor EEPROM Error | |
| FD_CHECK_ALM Check Alarm | | This parameter is used primarily to broadcast a change in the associated active conditions, which are not masked, for this alarm category to a Host System. | |
| UNACKNOWLEDGED Unacknowledged | RW | <p>A discrete enumeration which is set to "Unacknowledged" when an alarm occurs, and set to "Acknowledged" by a write from a human interface device or other entity which can acknowledge that the alarm/event has been noticed.</p> <p>Setting: Uninitialized / Acknowledged / Unacknowledged</p> | Uninitialized |
| ALARM_STATE Alarm State | R | <p>A discrete enumeration which gives an indication of whether the alert is active and whether it has been reported.</p> <p>Uninitialized / Clear - reported / Clear - not reported / Active - reported / Active - not reported</p> | Uninitialized |
| TIME_STAMP Time Stamp | R | <p>The time when evaluation of the block was started and a change in alarm/event state was detected that is unreported. The time stamp value will be maintained constant until alert confirmation has been received – even if another change of state occurs.</p> <p>Setting: MM / DD / YY (Month / Day / Year) HH:MM:SS (Hour:Minute:Second)</p> | Uninitialized |

| Parameter DD name | Access | Description and settings | Initial Value |
|---------------------------|--------|--|----------------|
| SUB_CODE Subcode | R | An enumeration specifying the cause of the alert to be reported. | |
| VALUE Value | R | The value of the associated parameter at the time the alert was detected. | |
| FD_CHECK_MAP Check Map | RW | <p>This parameter enables or disables conditions to be detected as active for this alarm category.</p> <p>Setting:</p> <ul style="list-style-type: none"> • {00} Check Function • {01} Cond01 • {02} Cond02 • {03} Cond03 • {04} Cond04 • {05} Cond05 • {06} Snapshot invalid • {07} Audio Signal Offset outside Range • {08} Reference Position outside Range • {09} Pulse Flange Lost • {10} No Probe detected • {11} Reference Lost Error • {12} Oscillator Frequency failure • {13} Temperature Above +75°C • {14} Temperature Below -35°C • {15} Overfill Warning • {16} Level Lost warning • {17} Temperature out of range (warning) • {18} Local operation • {19} Overfill Error • {20} Level lost error • {21} Temperature out of range Error • {22} Converter Voltage Error • {23} Converter ROM Error • {24} Converter RAM Error • {25} Converter EEPROM Error • {26} Sensor not compatible • {27} Internal Communication Error • {28} Sensor Voltage Error • {29} Sensor ROM Error • {30} Sensor RAM Error • {31} Sensor EEPROM Error | Nothing mapped |

| Parameter DD name | Access | Description and settings | Initial Value |
|---------------------------------------|--------|--|-------------------|
| FD_CHECK_MASK Check Mask | RW | <p>This parameter allows the user to suppress any single or multiple conditions that are active, in this category, from being broadcast to the host through the alarm parameter.</p> <p>Setting:</p> <ul style="list-style-type: none"> • (00) Check Function • (01) Cond01 • (02) Cond02 • (03) Cond03 • (04) Cond04 • (05) Cond05 • (06) Snapshot invalid disabled • (07) Audio Signal Offset outside Range disabled • (08) Reference Position outside Range disabled • (09) Pulse Flange Lost disabled • (10) No Probe detected • (11) Reference Lost Error • (12) Oscillator Frequency failure disabled • (13) Temperature Above +75°C disabled • (14) Temperature Below -35°C disabled • (15) Overfill Warning disabled • (16) Level Lost warning disabled • (17) Temperature out of range (warning) disabled • (18) Local operation disabled • (19) Overfill Error disabled • (20) Level lost error disabled • (21) Temperature out of range Error disabled • (22) Converter Voltage Error disabled • (23) Converter ROM Error disabled • (24) Converter RAM Error disabled • (25) Converter EEPROM Error disabled • (26) Sensor not compatible disabled • (27) Internal Communication Error disabled • (28) Sensor Voltage Error disabled • (29) Sensor ROM Error disabled • (30) Sensor RAM Error disabled • (31) Sensor EEPROM Error disabled | Nothing masked |
| FD_CHECK_PRI Check Priority | RW | <p>This parameter allows the user to specify the priority of this alarm category.</p> <p>Setting: 0...15</p> | 0 |

| Parameter DD name | Access | Description and settings | Initial Value |
|---|--------|---|---------------|
| FD_FAIL_ACTIVE Fail Active | R | <p>This parameter reflects the error conditions that are being detected as active as selected for this category. It is a bit string, so that multiple conditions may be shown.</p> <p>Setting:</p> <ul style="list-style-type: none"> • (00) Check Function • (01) Cond01 • (02) Cond02 • (03) Cond03 • (04) Cond04 • (05) Cond05 • (06) Snapshot invalid • (07) Audio Signal Offset outside Range • (08) Reference Position outside Range • (09) Pulse Flange Lost • (10) No Probe detected • (11) Reference Lost Error • (12) Oscillator Frequency failure • (13) Temperatur Above +75°C • (14) Temperature Below -35°C • (15) Overfill Warning • (16) Level Lost warning • (17) Temperature out of range (warning) • (18) Local operation • (19) Overfill Error • (20) Level lost error • (21) Temperature out of range Error • (22) Converter Voltage Error • (23) Converter ROM Error • (24) Converter RAM Error • (25) Converter EEPROM Error • (26) Sensor not compatible • (27) Internal Communication Error • (28) Sensor Voltage Error • (29) Sensor ROM Error • (30) Sensor RAM Error • (31) Sensor EEPROM Error | Uninitialized |
| FD_FAIL_ALM Fail Diagnostic Alarm | | This parameter is used primarily to broadcast a change in the associated active conditions, which are not masked, for this alarm category to a Host System. | |
| UNACKNOWLEDGED Unacknowledged | RW | <p>A discrete enumeration which is set to "Unacknowledged" when an alarm occurs, and set to "Acknowledged" by a write from a human interface device or other entity which can acknowledge that the alarm/event has been noticed.</p> <p>Setting: Uninitialized / Acknowledged / Unacknowledged</p> | Uninitialized |
| ALARM_STATE Alarm State | R | <p>A discrete enumeration which gives an indication of whether the alert is active and whether it has been reported.</p> <p>Setting: Uninitialized / Clear - reported / Clear - not reported / Active - reported / Active - not reported</p> | Uninitialized |
| TIME_STAMP Time Stamp | R | <p>The time when evaluation of the block was started and a change in alarm/event state was detected that is unreported. The time stamp value will be maintained constant until alert confirmation has been received - even if another change of state occurs.</p> <p>Setting: MM / DD / YY (Month / Day / Year) HH:MM:SS (Hour:Minute:Second)</p> | Uninitialized |

| Parameter DD name | Access | Description and settings | Initial Value |
|-------------------------|--------|--|---------------|
| SUB_CODE Subcode | R | An enumeration specifying the cause of the alert to be reported. | Other |
| VALUE Value | R | The value of the associated parameter at the time the alert was detected. Setting: State 0...16 | |
| FD_FAIL_MAP Fail Map | RW | This parameter enables or disables conditions to be detected as active for this alarm category. Setting: <ul style="list-style-type: none"> • (00) Check Function • (01) Cond01 • (02) Cond02 • (03) Cond03 • (04) Cond04 • (05) Cond05 • (06) Snapshot invalid • (07) Audio Signal Offset outside Range • (08) Reference Position outside Range • (09) Pulse Flange Lost • (10) No Probe detected • (11) Reference Lost Error • (12) Oscillator Frequency failure • (13) Temperature Above +75°C • (14) Temperature Below -35°C • (15) Overfill Warning • (16) Level Lost warning • (17) Temperature out of range (warning) • (18) Local operation • (19) Overfill Error • (20) Level lost error • (21) Temperature out of range Error • (22) Converter Voltage Error • (23) Converter ROM Error • (24) Converter RAM Error • (25) Converter EEPROM Error • (26) Sensor not compatible • (27) Internal Communication Error • (28) Sensor Voltage Error • (29) Sensor ROM Error • (30) Sensor RAM Error • (31) Sensor EEPROM Error | {00}-{31} |

| Parameter DD name | Access | Description and settings | Initial Value |
|---|--------|--|--------------------|
| FD_FAIL_MASK Fail Mask | RW | <p>This parameter allows the user to suppress any single or multiple conditions that are active, in this category, from being broadcast to the host through the alarm parameter.</p> <p>Setting:</p> <ul style="list-style-type: none"> • (00) Check Function • (01) Cond01 • (02) Cond02 • (03) Cond03 • (04) Cond04 • (05) Cond05 • (06) Snapshot invalid disabled • (07) Audio Signal Offset outside Range disabled • (08) Reference Position outside Range disabled • (09) Pulse Flange Lost disabled • (10) No Probe detected • (11) Reference Lost Error • (12) Oscillator Frequency failure disabled • (13) Temperature Above +75°C disabled • (14) Temperature Below -35°C disabled • (15) Overfill Warning disabled • (16) Level Lost warning disabled • (17) Temperature out of range (warning) disabled • (18) Local operation disabled • (19) Overfill Error disabled • (20) Level lost error disabled • (21) Temperature out of range Error disabled • (22) Converter Voltage Error disabled • (23) Converter ROM Error disabled • (24) Converter RAM Error disabled • (25) Converter EEPROM Error disabled • (26) Sensor not compatible disabled • (27) Internal Communication Error disabled • (28) Sensor Voltage Error disabled • (29) Sensor ROM Error disabled • (30) Sensor RAM Error disabled • (31) Sensor EEPROM Error disabled | (0)-(31) masked |
| FD_FAIL_PRI Fail Priority | RW | <p>This parameter allows the user to specify the priority of this alarm category.</p> <p>Setting: 0...15</p> | 0 |
| FD_MAINT_ACTIVE Maintenance Active | R | This parameter reflects the error conditions that are being detected as active as selected for the "Maintenance" category. It is a bit string, so that multiple conditions may be shown. | |
| FD_MAINT_ALM Fail Maintenance Alarm | | This parameter is used primarily to broadcast a change in the associated active conditions, which are not masked, for this alarm category to a Host System. | |
| UNACKNOWLEDGED Unacknowledged | RW | <p>A discrete enumeration which is set to "Unacknowledged" when an alarm occurs, and set to "Acknowledged" by a write from a human interface device or other entity which can acknowledge that the alarm/event has been noticed.</p> <p>Setting: Uninitialized / Acknowledged / Unacknowledged</p> | Uninitialized |

| Parameter DD name | Access | Description and settings | Initial Value |
|---------------------------------|--------|--|----------------|
| ALARM_STATE Alarm State | R | A discrete enumeration which gives an indication of whether the alert is active and whether it has been reported. Setting: Uninitialized / Clear - reported / Clear - not reported / Active - reported / Active - not reported | Uninitialized |
| TIME_STAMP Time Stamp | R | The time when evaluation of the block was started and a change in alarm/event state was detected that is unreported. The time stamp value will be maintained constant until alert confirmation has been received – even if another change of state occurs. Setting: MM / DD / YY (Month / Day / Year) HH:MM:SS (Hour:Minute:Second) | Uninitialized |
| SUB_CODE Subcode | R | An enumeration specifying the cause of the alert to be reported. | |
| VALUE Value | R | The value of the associated parameter at the time the alert was detected. | |
| FD_MAINT_MAP Maintenance Map | RW | This parameter enables or disables conditions to be detected as active for this alarm category. Setting: <ul style="list-style-type: none"> • (00) Check Function • (01) Cond01 • (02) Cond02 • (03) Cond03 • (04) Cond04 • (05) Cond05 • (06) Snapshot invalid • (07) Audio Signal Offset outside Range • (08) Reference Position outside Range • (09) Pulse Flange Lost • (10) No Probe detected • (11) Reference Lost Error • (12) Oscillator Frequency failure • (13) Temperature Above +75°C • (14) Temperature Below -35°C • (15) Overfill Warning • (16) Level Lost warning • (17) Temperature out of range (warning) • (18) Local operation • (19) Overfill Error • (20) Level lost error • (21) Temperature out of range Error • (22) Converter Voltage Error • (23) Converter ROM Error • (24) Converter RAM Error • (25) Converter EEPROM Error • (26) Sensor not compatible • (27) Internal Communication Error • (28) Sensor Voltage Error • (29) Sensor ROM Error • (30) Sensor RAM Error • (31) Sensor EEPROM Error | Nothing mapped |

| Parameter DD name | Access | Description and settings | Initial Value |
|---|--------|--|-------------------|
| FD_MAINT_MASK Maintenance Mask | RW | <p>This parameter allows the user to suppress any single or multiple conditions that are active, in this category, from being broadcast to the host through the alarm parameter.</p> <p>Setting:</p> <ul style="list-style-type: none"> • (00) Check Function • (01) Cond01 • (02) Cond02 • (03) Cond03 • (04) Cond04 • (05) Cond05 • (06) Snapshot invalid disabled • (07) Audio Signal Offset outside Range disabled • (08) Reference Position outside Range disabled • (09) Pulse Flange Lost disabled • (10) No Probe detected • (11) Reference Lost Error • (12) Oscillator Frequency failure disabled • (13) Temperature Above +75°C disabled • (14) Temperature Below -35°C disabled • (15) Overfill Warning disabled • (16) Level Lost warning disabled • (17) Temperature out of range (warning) disabled • (18) Local operation disabled • (19) Overfill Error disabled • (20) Level lost error disabled • (21) Temperature out of range Error disabled • (22) Converter Voltage Error disabled • (23) Converter ROM Error disabled • (24) Converter RAM Error disabled • (25) Converter EEPROM Error disabled • (26) Sensor not compatible disabled • (27) Internal Communication Error disabled • (28) Sensor Voltage Error disabled • (29) Sensor ROM Error disabled • (30) Sensor RAM Error disabled • (31) Sensor EEPROM Error disabled | Nothing masked |
| FD_MAINT_PRI Maintenance Priority | RW | <p>This parameter allows the user to specify the priority of this alarm category.</p> <p>Setting: 0...15</p> | 0 |

| Parameter DD name | Access | Description and settings | Initial Value |
|--|--------|--|---------------|
| FD_OFFSPEC_ACTIVE Offspec Active | R | <p>This parameter reflects the error conditions that are being detected as active as selected for this category. It is a bit string, so that multiple conditions may be shown.</p> <p>Setting:</p> <ul style="list-style-type: none"> • (00) Check Function • (01) Cond01 • (02) Cond02 • (03) Cond03 • (04) Cond04 • (05) Cond05 • (06) Snapshot invalid • (07) Audio Signal Offset outside Range • (08) Reference Position outside Range • (09) Pulse Flange Lost • (10) No Probe detected • (11) Reference Lost Error • (12) Oscillator Frequency failure • (13) Temperature Above +75°C • (14) Temperature Below -35°C • (15) Overfill Warning • (16) Level Lost warning • (17) Temperature out of range (warning) • (18) Local operation • (19) Overfill Error • (20) Level lost error • (21) Temperature out of range Error • (22) Converter Voltage Error • (23) Converter ROM Error • (24) Converter RAM Error • (25) Converter EEPROM Error • (26) Sensor not compatible • (27) Internal Communication Error • (28) Sensor Voltage Error • (29) Sensor ROM Error • (30) Sensor RAM Error • (31) Sensor EEPROM Error | |
| FD_OFFSPEC_ALM Offspec Alarm | | This parameter is used primarily to broadcast a change in the associated active conditions, which are not masked, for this alarm category to a Host System. | |
| UNACKNOWLEDGED Unacknowledged | RW | <p>A discrete enumeration which is set to Unacknowledged when an alarm occurs, and set to Acknowledged by a write from a human interface device or other entity which can acknowledge that the alarm/event has been noticed.</p> <p>Setting: Uninitialized / Acknowledged / Unacknowledged</p> | Uninitialized |
| ALARM_STATE Alarm State | R | <p>A discrete enumeration which gives an indication of whether the alert is active and whether it has been reported.</p> <p>Setting: Uninitialized / Clear - reported / Clear - not reported / Active - reported / Active - not reported</p> | Uninitialized |
| TIME_STAMP Time Stamp | R | <p>The time when evaluation of the block was started and a change in alarm/event state was detected that is unreported. The time stamp value will be maintained constant until alert confirmation has been received – even if another change of state occurs.</p> <p>Setting: MM / DD / YY (Month / Day / Year) HH:MM:SS (Hour:Minute:Second)</p> | Uninitialized |

| Parameter DD name | Access | Description and settings | Initial Value |
|-------------------------------|--------|--|----------------|
| SUB_CODE Subcode | R | An enumeration specifying the cause of the alert to be reported. | Other |
| VALUE Value | R | The value of the associated parameter at the time the alert was detected. | |
| FD_OFFSPEC_MAP Offspec Map | RW | <p>This parameter enables or disables conditions to be detected as active for this alarm category.</p> <p>Setting:</p> <ul style="list-style-type: none"> • (00) Check Function • (01) Cond01 • (02) Cond02 • (03) Cond03 • (04) Cond04 • (05) Cond05 • (06) Snapshot invalid • (07) Audio Signal Offset outside Range • (08) Reference Position outside Range • (09) Pulse Flange Lost • (10) No Probe detected • (11) Reference Lost Error • (12) Oscillator Frequency failure • (13) Temperature Above +75°C • (14) Temperature Below -35°C • (15) Overfill Warning • (16) Level Lost warning • (17) Temperature out of range (warning) • (18) Local operation • (19) Overfill Error • (20) Level lost error • (21) Temperature out of range Error • (22) Converter Voltage Error • (23) Converter ROM Error • (24) Converter RAM Error • (25) Converter EEPROM Error • (26) Sensor not compatible • (27) Internal Communication Error • (28) Sensor Voltage Error • (29) Sensor ROM Error • (30) Sensor RAM Error • (31) Sensor EEPROM Error | Nothing mapped |

| Parameter DD name | Access | Description and settings | Initial Value |
|---|--------|--|-------------------|
| FD_OFFSPEC_MASK Offspec Mask | RW | <p>This parameter allows the user to suppress any single or multiple conditions that are active, in this category, from being broadcast to the host through the alarm parameter.</p> <p>Setting:</p> <ul style="list-style-type: none"> • (00) Check Function • (01) Cond01 • (02) Cond02 • (03) Cond03 • (04) Cond04 • (05) Cond05 • (06) Snapshot invalid disabled • (07) Audio Signal Offset outside Range disabled • (08) Reference Position outside Range disabled • (09) Pulse Flange Lost disabled • (10) No Probe detected • (11) Reference Lost Error • (12) Oscillator Frequency failure disabled • (13) Temperature Above +75°C disabled • (14) Temperature Below -35°C disabled • (15) Overfill Warning disabled • (16) Level Lost warning disabled • (17) Temperature out of range (warning) disabled • (18) Local operation disabled • (19) Overfill Error disabled • (20) Level lost error disabled • (21) Temperature out of range Error disabled • (22) Converter Voltage Error disabled • (23) Converter ROM Error disabled • (24) Converter RAM Error disabled • (25) Converter EEPROM Error disabled • (26) Sensor not compatible disabled • (27) Internal Communication Error disabled • (28) Sensor Voltage Error disabled • (29) Sensor ROM Error disabled • (30) Sensor RAM Error disabled • (31) Sensor EEPROM Error disabled | Nothing masked |
| FD_OFFSPEC_PRI Offspec Priority | RW | <p>This parameter allows the user to specify the priority of this alarm category.</p> <p>Setting: 0...15</p> | 0 |

| Parameter DD name | Access | Description and settings | Initial Value |
|---------------------------------------|--------|---|---------------|
| FD_RECOMMEN_ACT Recommended Action | R | <p>This parameter is a device enumerated summarization of the most severe condition or conditions detected. The DD help should describe by enumerated action, what should be done to alleviate the condition or conditions.</p> <p>Setting:</p> <ul style="list-style-type: none"> • Uninitialized • The device operates satisfactorily. No action is required. • The "Simulate" jumper is installed. Remove the jumper to go back to normal operation. • The Transducer Block into AUTO mode. Set Transducer Block into AUTO mode. • Make sure that the HART Slave operates satisfactorily • Contact the supplier • Replace the electronics module or contact the supplier • Check the power supply at the device terminals. If the voltage is correct, contact the supplier. • Measure the voltage at the device terminals. Make sure that the internal cable is connected between the front end and the back end. For remote configuration, make sure that that the electrical wires are connected to the terminals. If necessary, contact the supplier. • Temperature is above +85°C / +185°F or below -45°C / -49°F. Process temperature or ambient temperature is above the maximum limit or below the minimum limit. Action: Measure the device temperature. • Firmware incompatibility. Contact the supplier. • Replace the electronics module or contact the supplier • Measure the level signal amplitude of the device. Configure the device. If necessary, contact the supplier. • The level signal is in the blocking distance. Action: Lower the level until it is below the blocking distance. • Make sure that the probe is attached to the process connection. If necessary, contact the supplier. • Risk of device failure. Replace the electronics module or contact the supplier. • Do a check of the device, the tank and the process. Action: do a new snapshot of the tank contents. Use the snapshot to filter parasitic signals. If necessary, contact the supplier. • Risk of device failure. Replace the electronics module or contact the supplier. • Risk of device failure. Replace the electronics module or contact the supplier. • The electronics block is near to its minimum or maximum operating temperature. Action: Measure the device temperature. • The electronics block is near to its minimum or maximum operating temperature. Action: Measure the device temperature. • Temperature is above +85°C / +185°F or below -45°C / -49°F. Process temperature or ambient temperature is above the maximum limit or below the minimum limit. Action: Measure the device temperature. • Check the level signal amplitude of the device. Configure the device. If necessary, contact the supplier. Recommended action for Condition 27 • The level signal is in the blocking distance. Action: Lower the level until it is below the blocking distance. • The device is in configuration mode after a user used the local display to enter a menu. Action: Use the local display to go back to normal mode. • Unknown Alarm Event appeared | Uninitialized |

| Parameter DD name | Access | Description and settings | Initial Value |
|--|--------|--|---------------|
| FD_SIMULATE Field Diagnostic Simulate | | Used as the field diagnostic condition when the simulation is enabled. | |
| DIAGNOSTIC_SIMULATE E_VALUE Diagnostic Simulate Value | RW | <p>Allows the conditions to be manually supplied when simulation is enabled. The simulate jumper is required for simulation to be enabled.</p> <p>Setting:</p> <ul style="list-style-type: none"> • (00) Check Function • (01) Cond01 • (02) Cond02 • (03) Cond03 • (04) Cond04 • (05) Cond05 • (06) Snapshot invalid • (07) Audio Signal Offset outside Range • (08) Reference Position outside Range • (09) Pulse Flange Lost • (10) No Probe detected • (11) Reference Lost Error • (12) Oscillator Frequency failure • (13) Temperature Above +75°C • (14) Temperature Below -35°C • (15) Overfill Warning • (16) Level Lost warning • (17) Temperature out of range (warning) • (18) Local operation • (19) Overfill Error • (20) Level lost error • (21) Temperature out of range Error • (22) Converter Voltage Error • (23) Converter ROM Error • (24) Converter RAM Error • (25) Converter EEPROM Error • (26) Sensor not compatible • (27) Internal Communication Error • (28) Sensor Voltage Error • (29) Sensor ROM Error • (30) Sensor RAM Error • (31) Sensor EEPROM Error | Uninitialized |

| Parameter DD name | Access | Description and settings | Initial Value |
|---------------------------------------|--------|--|---------------|
| DIAGNOSTIC_VALUE Diagnostic Value | R | Current field diagnostic condition. Setting: <ul style="list-style-type: none"> • {00} Check Function • {01} Cond01 • {02} Cond02 • {03} Cond03 • {04} Cond04 • {05} Cond05 • {06} Snapshot invalid • {07} Audio Signal Offset outside Range • {08} Reference Position outside Range • {09} Pulse Flange Lost • {10} No Probe detected • {11} Reference Lost Error • {12} Oscillator Frequency failure • {13} Temperature Above +75°C • {14} Temperature Below -35°C • {15} Overfill Warning • {16} Level Lost warning • {17} Temperature out of range (warning) • {18} Local operation • {19} Overfill Error • {20} Level lost error • {21} Temperature out of range Error • {22} Converter Voltage Error • {23} Converter ROM Error • {24} Converter RAM Error • {25} Converter EEPROM Error • {26} Sensor not compatible • {27} Internal Communication Error • {28} Sensor Voltage Error • {29} Sensor ROM Error • {30} Sensor RAM Error • {31} Sensor EEPROM Error | Uninitialized |
| ENABLE_DISABLE Simulate En/Disable | RW | Enable/disable simulation. Setting: Uninitialized / Disabled / Active | Uninitialized |
| FD_VER Revision | R | The major version of the Field Diagnostics specification used for the development of this device. | 1 |
| PASSWRD Password | RW | Password to activate access rights to restricted parameters | 0 |
| PROTECT_INFO access protection | R | Setting: bit 5...7: not use / User / Service level / Production / Custody Transfer / Write Lock | Production |
| SERIAL_NUMBER Seriennummer | R | Device serial number, serial number of the system. | |
| SW_SIMULATE SW Simulation | RW | Enable/disable simulation like simulate hardware jumper. Setting: Disabled / Active | Disabled |

4.5 Analog Input Block (AI 1...3)

The following tables list the Analog Input Block parameters in alphabetical order.

It describes characteristics of the measurement values obtained from the Transducer Block in a user defined way and to deliver it to the control system. There are also some parameters in the Analog Input Block, that can be configured to get a measurement value quality as desired by the user.

The following tables contain short parameter description, factory settings (Initial Value (IV)) and possible settings.

| Parameter DD name | Access | Description and settings | Initial Value |
|----------------------------------|--------|---|----------------------|
| Alert Key | RW | The identification number of the plant unit. This information may be used in the host for sorting alarms, etc. Setting: 1...255 | 0 |
| BLOCK_ERR Block Error | R | This parameter reflects the error status associated with the hardware or software components associated with a block. It is a bit string, so that multiple errors may be shown. Setting: <ul style="list-style-type: none"> • Other: Non-specific error active • Block Configuration: Error detected in block configuration • Link Configuration: Error detected in link configuration • Simulation Active: Simulation enabled in this block • Local Override: Output tracking of fault state active • Device Fault State: Device fault state set • Device Maintenance: Device needs maintenance soon • Input Failure: Process variable has bad status • Output Failure: Failure detected in output hardware • Memory Failure: Memory error detected • Lost Static Data: Static parameters cannot be recovered • Lost NV Data: Non-volatile parameters cannot be recovered • Readback Check: Failure detected in READBACK • Maintenance Needed: Device NEEDS maintenance NOW • Power Up: Recovery from power failure • Out Of Service: Block actual mode is out of service | OOS (Out of Service) |
| MODE_BLK Block Mode | | The actual, target, permitted and normal modes of the block. | - |
| TARGET Target | RW | By setting this parameter to an allowed value (one of the value from permitted modes) user can change the block execution mode. Changing of modes is required to change the access permissions available to various parameters. Setting: Auto / OOS | OOS |

| Parameter DD name | Access | Description and settings | Initial Value |
|----------------------------------|--------|--|---------------|
| ACTUAL Actual | R | This is the current mode of the block, which may differ from the target based on operating conditions. 1st value is calculated as part of block execution. | OOS |
| | | Setting: Auto / OOS | |
| PERMITTED Permitted | RW | Defines the modes which are allowed for an instance in the block. The permitted mode is configured based on application requirements. | Auto / OOS |
| | | Setting: Auto / OOS | |
| NORMAL Normal | RW | This is the mode which the block should be set to during normal operating conditions. | Auto |
| | | Setting: Auto / OOS | |
| ST_REV Static Revision | R | The revision level of the static data associated with the function block. The revision value will be incremented each time a static parameter value in the block is changed. | 0 |
| | | Setting: 0...65535 | |
| STRATEGY Strategy | RW | The strategy field can be used to identify grouping of blocks. This data is not checked or processed by the block. | 0 |
| | | Setting: 0...65535 | |
| TAG_DESC Tag Description | RW | This is the user description of the intended application of the block. | blanks |
| | | Setting: ≤32 digits | |
| ACK_OPTION Acknowledge Option | RW | Selection of whether alarms associated with the function block will be automatically acknowledged. | Uninitialized |
| | | Setting: HiHi Alm Auto Ack / Hi Alm Auto Ack / LoLo Alm Auto Ack / Lo Alm Auto Ack / Blk Alm Auto Ack / Fail Alm Auto Ack / Off Spec Alm Auto Ack / Maint Alm Auto Ack / Check Alm Auto Ack | |
| ALARM_HYS Alarm Hysteresis | RW | The amount by which the PV must return within the alarm limits before the alarm condition clears. Alarm hysteresis is expressed as a percentage of the PV span. | 0.5 |
| | | Setting: 0...50% | |
| ALARM_SUM Alarm Summary | | The current alert status, unacknowledged states, unreported states and disabled states of the alarms associated with the function block. | |
| CURRENT Current | R | The active status of each alarm. | Uninitialized |
| | | Setting: HiHi Alarm / Hi Alarm / LoLo Alarm / Lo Alarm / Block Alarm | |

| Parameter DD name | Access | Description and settings | Initial Value |
|--|--------|--|---------------|
| UNACKNOWLEDGED Unacknowledged | R | The unacknowledged state of each alarm. Setting: HiHi Alarm Unack / Hi Alarm Unack / LoLo Alarm Unack / Lo Alarm Unack / Block Alarm Unack | Uninitialized |
| UNREPORTED Unreported | R | The unreported states of each alarm. Setting: HiHi Alarm Unrep / Hi Alarm Unrep / LoLo Alarm Unrep / Lo Alarm Unrep / Block Alarm Unrep | Uninitialized |
| DISABLED Disabled | R | The disabled state of each alarm Setting: HiHi Alarm Disabled / Hi Alarm Disabled / LoLo Alarm Disabled / Lo Alarm Disabled / Block Alarm Disabled | Uninitialized |
| BLOCK_ALM Block Alarm | | The block alarm is used for all configuration, hardware, connection failure or system problems in the block. The cause of the alert is entered in the subcode field. The first alert to become active will set the "Active" status in the "Status" attribute. As soon as the "Unreported" status is cleared by the alert reporting task, another block alert may be reported without clearing the "Active" status, if the subcode has changed. | - |
| UNACKNOWLEDGED Unacknowledged | RW | A discrete enumeration which is set to "Unacknowledged" when an alarm occurs, and set to "Acknowledged" by a write from a human interface device or other entity which can acknowledge that the alarm/event has been noticed. Setting: Uninitialized / Acknowledged / Unacknowledged | Uninitialized |
| ALARM_STATE Alarm State | R | A discrete enumeration which gives an indication of whether the alert is active and whether it has been reported. Setting: Uninitialized / Clear - reported / Clear - not reported / Active - reported / Active - not reported | Uninitialized |
| TIME_STAMP Time Stamp | R | The time when evaluation of the block was started and a change in alarm/event state was detected that is unreported. The time stamp value will be maintained constant until alert confirmation has been received - even if another change of state occurs. Setting: MM / DD / YY (Month / Day / Year) HH:MM:SS (Hour:Minute:Second) | Uninitialized |

| Parameter DD name | Access | Description and settings | Initial Value |
|--------------------------|--------|---|---------------|
| SUB_CODE Subcode | R | An enumeration specifying the cause of the alert to be reported. Setting: Other / Block Configuration / Link Configuration / Simulation Active / Local Override / Device Fault State / Device Maintenance / Input Failure / Output Failure / Memory Failure / Lost Static Data / Lost NV Data / Readback Check / Maintenance Needed / Power Up / Out Of Service | Other |
| VALUE Value | R | The value of the associated parameter at the time the alert was detected. Setting: 0...255 | 0 |
| CHANNEL Channel | RW | The number of the logical hardware channel that is connected to this I/O block. This information defines the transducer to be used going to or from the physical world. Setting: 0. Uninitialized 1. Level 2. Distance 3. Conversion 4. Distance conversion | 0 |
| FIELD_VAL Field Value | | Raw value of the field device in percent of the PV range, with a status reflecting the transducer condition, before signal characterization (L_TYPE) or filtering (PV_FTIME). | |
| STATUS Status | R | Digital transducers, unlike their analogue versions, can detect faults that make the measurement bad or prevent the actuator from responding. This additional, valuable information will be passed along with each transmission of a data value in the form of a status attribute. | |
| VALUE Value | R | A numerical quantity entered by a user or calculated by the algorithm. | 0.0 |
| GRANT_DENY Grant Deny | | Options for controlling access of host computers and local control panels to operating, tuning and alarm parameters of the block. | |
| GRANT Grant | RW | Depending on the philosophy of the plant, the operator or a higher level device (HLD) or a local operator's panel (LOP) in the case of "Local", may turn on an item of the "Grant" attribute - "Program, Tune, Alarm or Local". Setting: Program / Tune / Alarm / Local / Operate | Uninitialized |
| DENY Deny | RW | The deny attribute is provided for use by a monitoring application in an interface device and may not be changed by an operator. Setting: Program denied / Tune denied / Alarm denied / Local denied / Operate denied | Uninitialized |
| HI_ALM High Alarm | | The status for High Alarm and its associated time stamp. For settings of the 5 sub-elements, refer to the "Unacknowledged", "Alarm State", "Time Stamp", "Subcode" and "Value" items that follow. | - |

| Parameter DD name | Access | Description and settings | Initial Value |
|---|--------|---|---------------|
| HI_HI_ALM High High Alarm | | The status for High High Alarm and its associated time stamp. For settings of the 5 sub-elements, refer to the "Unacknowledged", "Alarm State", "Time Stamp", "Subcode" and "Value" items that follow. | - |
| Settings of 5 sub-elements for the parameters "High Alarm" and "High High Alarm": | | | |
| UNACKNOWLEDGED Unacknowledged | RW | Setting: Uninitialized / Acknowledged / Unacknowledged | Uninitialized |
| ALARM_STATE Alarm State | R | Setting: Uninitialized / Clear - reported / Clear - not reported / Active - reported / Active - not reported | Uninitialized |
| TIME_STAMP Time Stamp | R | Setting: MM / DD / YY (Month / Day / Year) HH:MM:SS (Hour:Minute:Second) | Uninitialized |
| SUB_CODE Subcode | R | Setting: Other/ Block Configuration / Link Configuration / Simulation Active / Local Override / Device Fault State / Device Maintenance / Input Failure / Output Failure / Memory Failure / Lost Static Data / Lost NV Data / Readback Check / Maintenance Needed / Power Up / Out Of Service | Other |
| VALUE Float Value | R | A numerical quantity entered by a user or calculated by the algorithm. | 0.0 |
| HI_HI_LIM High High Limit | RW | The setting for High High Alarm in engineering units. For the setting range, refer to the "x_y_LIM" item that follows. | NaN |
| HI_HI_PRI High High Priority | RW | Priority of the High High Alarm. For the setting range, refer to the "x_y_PRI" item that follows. | 0 |
| HI_LIM High Limit | RW | The setting for High Alarm in engineering units. For the setting range, refer to the "x_y_LIM" item that follows. | NaN |
| HI_PRI High Priority | RW | Priority of the High Alarm. For the setting range, refer to the "x_y_PRI" item that follows. | 0 |
| Setting range for the parameters "High High Limit" and "High Limit": x_y_LIM x_y_Limit | | -3.39 E38...+3.39 E38 / - INF (- infinite) / + INF (+ infinite) | |
| Setting range for the parameters "High High Priority" and "High Priority": x_y_PRI x_y_Priority | | Setting: 0...15 | 0 |
| IO_OPTS IO Options (IO = Input/Output) | RW | Options which the user may select to alter input and output block processing. Setting: Low Cutoff / Units Conversion | Uninitialized |
| L_TYPE Linearization Type | RW | Determines if the values passed by the TB to the AI block may be used directly (Direct) or if the value is in different units and must be converted linearly (Indirect) , or with square root (Ind Sqr Root), using the input range defined for the transducer and the associated output range. Setting: Uninitialized / Direct / Indirect / Ind Sqr Root | Uninitialized |
| LO_ALM Low Alarm | | The status for Low Alarm and its associated time stamp. For settings of the 5 sub-elements, refer to the "Unacknowledged", "Alarm State", "Time Stamp", "Subcode" and "Value" items that follow. | - |

| Parameter DD name | Access | Description and settings | Initial Value |
|--|--------|---|---------------|
| LO_LO_ALM Low Low Alarm | | The status for Low Low Alarm and its associated time stamp. For settings of the 5 sub-elements, refer to the "Unacknowledged", "Alarm State", "Time Stamp", "Subcode" and "Value" items that follow. | - |
| Settings of 5 sub-elements for the parameters "Low Alarm" and "Low Low Alarm": | | | |
| UNACKNOWLEDGED Unacknowledged | RW | Setting: Uninitialized / Acknowledged / Unacknowledged | Uninitialized |
| ALARM_STATE Alarm State | R | Setting: Uninitialized / Clear - reported / Clear - not reported / Active - reported / Active - not reported | Uninitialized |
| TIME_STAMP Time Stamp | R | Setting: MM / DD / YY (Month / Day / Year) HH:MM:SS (Hour:Minute:Second) | Uninitialized |
| SUB_CODE Subcode | R | Setting: Other / Block Configuration / Link Configuration / Simulation Active / Local Override / Device Fault State / Device Maintenance / Input Failure / Output Failure / Memory Failure / Lost Static Data / Lost NV Data / Readback Check / Maintenance Needed / Power Up / Out Of Service | Other |
| VALUE Float Value | R | A numerical quantity entered by a user or calculated by the algorithm. | 0.0 |
| LO_LIM Low Limit | R | The setting for Low Alarm in engineering units. For the setting range, refer to the "x_y_LIM" item that follows. | (-NaN) |
| LO_LO_LIM Low Low Limit | RW | The setting for Low Low Alarm in engineering units. For the setting range, refer to the "x_y_LIM" item that follows. | (-NaN) |
| LO_PRI Low Priority | RW | Priority of the Low Alarm. For the setting range, refer to the "x_y_PRI" item that follows. | 0 |
| LO_LO_PRI Low Low Priority | RW | Priority of the Low Low Alarm. For the setting range, refer to the "x_y_PRI" item that follows. | 0 |
| Setting range for the parameters "Low Low Limit" and "Low Limit": x_y_LIM x_y_Limit | | -3.39 E38...+3.39 E38 / - INF (- infinite) / + INF (+ infinite) | |
| Setting range for the parameters "Low Low Priority" and "Low Priority": x_y_PRI x_y_Priority | | Setting: 0...15 | 0 |
| LOW_CUT Low Cutoff | RW | Limit used in square root processing. A value of zero percent of scale is used in block processing if the transducer value falls below this limit, in %of scale. This feature may be used to eliminate noise near zero for a flow sensor. Setting: ≥0.0 | 0.0 |
| OUT Output | RW | The primary analogue discrete value calculated as a result of executing the function. | |

| Parameter DD name | Access | Description and settings | Initial Value |
|--|--------|--|---------------|
| STATUS Status | R | Digital transducers, unlike their analogue versions, can detect faults that make the measurement bad or prevent the actuator from responding. This additional, valuable information will be passed along with each transmission of a data value in the form of a status attribute. | |
| VALUE Value | RW | A numerical quantity entered by a user or calculated by the algorithm. | 0.0 |
| OUT_SCALE Output Scale | RW | The high and low scale values, engineering units code and number of digits to the right of the decimal point to be used in displaying the OUT parameter and parameters which have the same scaling as OUT. | |
| EU_100 EU at 100% | RW | The engineering unit value which represents the upper end of range of the associated block parameter. | 100.0 |
| EU_0 EU at 0% | RW | The engineering unit value which represents the lower end of range of the associated block parameter. | 0.0 |
| UNITS_INDEX Units Index | RW | Device Description units code index for the engineering unit descriptor for the associated block value. Setting: All units are possible. | Uninitialized |
| DECIMAL Decimal | RW | The number of digits to the right of the decimal point which should be used by an interface device in displaying the specified parameter. | 0 |
| PV Process Value | | Either the primary analog value for use in executing the function, or a process value associated with it. May also be calculated from the RBACK value of an AO block. | - |
| STATUS Status | R | Digital transducers, unlike their analogue versions, can detect faults that make the measurement bad or prevent the actuator from responding. This additional, valuable information will be passed along with each transmission of a data value in the form of a status attribute. | 0 |
| VALUE Value | R | A numerical quantity entered by a user or calculated by the algorithm. | 0.0 |
| PV_FTIME Process Value Filter Time | RW | Time constant of a single exponential filter for the PV, in seconds. Setting: 0.0...60.0 | 0.0 |
| SIMULATE Simulate | | Allows the transducer analog input or output to the block to be manually supplied when simulate is enabled. When simulate is disabled, the simulate value and status track the actual value and status. | |
| SIMUULATE_STATUS Simulate Status | RW | Used for the transducer status when simulation is enabled. | 0 |
| SIMULATE_VALUE Simulate Value | RW | Used for the transducer value when simulation is enabled. Setting: -3.39E38...+3.39E38 / -INF (-infinite) / + INF (+infinite) | 0.0 |
| TRANSDUCER_ STATUS Transducer Status | R | Status of value supplied by transducer. | 0 |
| TRANSDUCER_ VALUE Transducer Value | R | Current value supplied by transducer. | 0.0 |
| ENABLE_DISABLE Simulate En/Disable | RW | The parameter "SW_Simulated" in RB Block must be enabled. Setting: Uninitialized / Disabled / Active | Disabled |

| Parameter DD name | Access | Description and settings | Initial Value |
|----------------------------------|--------|--|---|
| STATUS_OPTS Status Option | RW | Options which the user may select in the block processing of status. | Uninitialized |
| | | Setting: Propagate Fault Forward / Uncertain if limited / BAD if limited / Uncertain if Man. | |
| UPDATE_EVT Update Event | | This alert is generated by any change to the static data. | |
| UNACKNOWLEDGED Unacknowledged | RW | A discrete enumeration which is set to "Unacknowledged" when an alarm occurs, and set to "Acknowledged" by a write from a human interface device or other entity which can acknowledge that the alarm/event has been noticed. | Uninitialized |
| | | Setting: Uninitialized / Acknowledged / Unacknowledged | |
| UPDATE_STATE Update State | R | A discrete enumeration which gives an indication of whether the alert has been reported. | Uninitialized |
| | | Setting: Uninitialized / Reported / Not Reported | |
| TIME_STAMP Time Stamp | R | The time when evaluation of the block was started and a change in alarm/event state was detected that is unreported. The time stamp value will be maintained constant until alert confirmation has been received - even if another change of state occurs. | Uninitialized |
| | | Setting: MM / DD / YY (Month / Day / Year) HH:MM:SS (Hour:Minute:Second) | |
| STATIC_REVISION Static Rev | R | The static revision of the block whose static parameter was changed and is being reported. It is possible for the present value of static revision to be greater than this because static can be changed at any time. | 0 |
| RELATIVE_INDEX Relative Index | R | The OD index of the static parameter whose change caused this alert, minus the FB starting index. If the update event was caused by a write to multiple parameters at the same time, then this attribute will be zero. | 0 |
| XD_SCALE Transducer Scale | RW | The high and low scale values, engineering units code and number of digits to the right of the decimal point used with the value obtained from the transducer for a specified channel. | - |
| EU_100 EU at 100% | RW | The engineering unit value which represents the upper end of range of the associated block parameter. | 100.0 |
| EU_0 EU at 0% | RW | The engineering unit value which represents the lower end of range of the associated block parameter. | 0.0 |
| UNITS_INDEX Units Index | RW | Device Description units code index for the engineering unit descriptor for the associated block value. | Depends on the type, the device is calibrated for |
| | | Units: m; cm; mm; ft; in; gal; L; ImpGal; m ³ ; bbl; ft ³ ; kg; t; STon; LTon | |
| DECIMAL Decimal | RW | The number of digits to the right of the decimal point which should be used by an interface device in displaying the specified parameter. | 0 |

4.6 Transducer Block (TB)

The following tables list the Transducer Block parameters in alphabetical order.

It describes characteristics of the sensor output functions required to read the measurement value from the Function Blocks.

The following tables contain short parameter description, factory settings (Initial Value (IV)) and possible settings.

4.6.1 Transducer "Level" Block

| Parameter DD name | Access | Description and settings | Initial Value |
|---------------------------------|--------|--|---------------|
| ALERT_KEY Alert Key | RW | The identification number of the plant unit. This information may be used in the host for sorting alarms, etc. Setting: 1...255 | 0 |
| BLOCK_ERR Block Error | R | This parameter reflects the error status associated with the hardware or software components associated with a block. It is a bit string, so that multiple errors may be shown. Setting: <ul style="list-style-type: none"> • Other: Non-specific error active • Block Configuration: Error detected in block configuration • Link Configuration: Error detected in link configuration • Simulation Active: Simulation enabled in this block • Local Override: Output tracking of faultstate active • Device Fault State: Device faultstate set • Device Maintenance: Device needs maintenance soon • Input Failure: Process variable has bad status • Output Failure: Failure detected in output hardware • Memory Failure: Memory error detected • Lost Static Data: Static parameters cannot be recovered • Lost NV Data: Non-volatile parameters cannot be recovered • Readback Check: Failure detected in READBACK • Maintenance Needed: Device NEEDS maintenance NOW • Power Up: Recovery from power failure • Out Of Service: Block actual mode is out of service | Other |
| MODE_BLK Block Mode | | The actual, target, permitted and normal modes of the block. | |
| TARGET Target | R/W | This is the mode requested by the operator. Only one mode from those allowed by the permitted mode parameter may be requested. Setting: Auto / OOS | Auto |
| ACTUAL Actual | R | This is the current mode of the block, which may differ from the target based on operating conditions. Its value is calculated as part of block execution. Setting: Auto / OOS | Auto |
| PERMITTED Permitted | R/W | Defines the modes which are allowed for an instance of the block. The permitted mode is configured based on application requirement. Setting: Auto / OOS | Auto OOS |

| Parameter DD name | Access | Description and settings | Initial Value |
|----------------------------------|--------|--|---------------|
| NORMAL Normal | R/W | This is the mode which the block should be set to during normal operating conditions. | Auto |
| | | Setting: Auto / OOS | |
| ST_Rev Static Revision | R | The revision level of the static data associated with the function block. The revision value will be incremented each time a static parameter value in the block is changed. | 0 |
| | | Setting: 0...65535 | |
| STRATEGY Strategy | RW | The strategy field can be used to identify grouping of blocks. This data is not checked or processed by the block. | 0 |
| | | Setting: 0...65535 | |
| TAG_DESC Tag Description | RW | The user description of the intended application of the block. | spaces |
| | | Setting: ≤32 digits | |
| BLOCK_ALM Block Alarm | | The block alarm is used for all configuration, hardware, connection failure or system problems in the block. The cause of the alert is entered in the subcode field. The first alert to become active will set the "Active" status in the "Status" attribute. As soon as the "Unreported" status is cleared by the alert reporting task, another block alert may be reported without clearing the "Active" status, if the subcode has changed. | |
| UNACKNOWLEDGED Unacknowledged | RW | A discrete enumeration which is set to "Unacknowledged" when an alarm occurs, and set to "Acknowledged" by a write from a human interface device or other entity which can acknowledge that the alarm/event has been noticed. | Uninitialized |
| | | Setting: Uninitialized / Acknowledged / Unacknowledged | |
| ALARM_STATE Alarm State | R | A discrete enumeration which gives an indication of whether the alert is active and whether it has been reported. | Uninitialized |
| | | Setting: Uninitialized / Clear - reported / Clear - not reported / Active - reported / Active - not reported | |
| TIME_STAMP Time Stamp | R | The time when evaluation of the block was started and a change in alarm/event state was detected that is unreported. The time stamp value will be maintained constant until alert confirmation has been received - even if another change of state occurs. | Uninitialized |
| | | Setting: MM / DD / YY (Month / Day / Year) HH:MM:SS (Hour:Minute:Second) | |
| SUB_CODE Subcode | R | An enumeration specifying the cause of the alert to be reported. | Other |
| | | Setting: Other / Block Configuration / Link Configuration / Simulation Active / Local Override / Device Fault State / Device Maintenance / Input Failure / Output Failure / Memory Failure / Lost Static Data / Lost NV Data / Readback Check / Maintenance Needed / Power Up / Out Of Service | |
| VALUE Value | R | The value of the associated parameter at the time the alert was detected. | 0 |
| | | Setting: 0...255 | |
| UPDATE_EVT Update Event | | This alert is generated by any change to the static data. | |

| Parameter DD name | Access | Description and settings | Initial Value |
|--|--------|--|---------------|
| UNACKNOWLEDGED Unacknowledged | R/W | A discrete enumeration which is set to "Unacknowledged" when an alarm occurs, and set to "Acknowledged" by a write from a human interface device or other entity which can acknowledge that the alarm/event has been noticed. Setting: Uninitialized / Acknowledged / Unacknowledged | Uninitialized |
| UPDATE_STATE Update State | R | A discrete enumeration which gives an indication of whether the alert has been reported. Setting: Uninitialized / Update reported / Update not reported | Uninitialized |
| TIME_STAMP Time Stamp | R | The time when evaluation of the block was started and a change in alarm/event state was detected that is unreported. The time stamp value will be maintained constant until alert confirmation has been received - even if another change of state occurs. Setting: MM / DD / YY (Month / Day / Year) HH:MM:SS (Hour:Minute:Second) | Uninitialized |
| STATIC_REVISION Static Revision | R | The static revision of the block whose static parameter was changed and is being reported. It is possible for the present value of static revision to be greater than this because static can be changed at any time. Setting: 0...65535 | 0 |
| RELATIVE_INDEX Relative Index | R | The OD index of the static parameter whose change caused this alert, minus the FB starting index. If the update event was caused by a write to multiple parameters at the same time, then this attribute will be zero. Setting: 0...65535 | 0 |
| AUTO_EPSILON_R Automatic calculation of dielectric constant | RW | Enables/disables automatic calculation of the dielectric constant of the filling medium. Setting: No / Yes | |
| BLOCKING_DISTANCE Blocking Distance | RW | The non-measuring range at the top of the probe. It depends on the probe type and the installation. Setting: 0...PROBE_LENGTH | |
| CAL_MIN_SPAN Calibration Minimum Span | R | The minimum calibration span allowed. Ensures that the two calibrated points (high and low) are not too close together. | |
| CAL_POINT_HI Calibration Highest Point | R | The highest calibrated value. | |
| CAL_POINT_LO Calibration Lowest Point | R | The lowest calibrated value. | |
| CAL_UNIT Calibration Units | R | The Device description engineering units code index for the calibration values. | |
| CALSPEED_ELECTRONIC Electronics Calspeed | RW | Electronics Calspeed | |
| CALSPEED_MECHANIC Mechanical Calspeed | RW | Mechanical Calspeed | |

| Parameter DD name | Access | Description and settings | Initial Value |
|--|--------|--|-------------------|
| COLLECTION_DIRECTORY Collection Directory | | A directory that specifies the number, starting indices and DD Item IDs of the data collections in each transducer within a Transducer Block. | - |
| COUNTERWEIGHT_HEIGHT Counterweight height | RW | For installations where a cable probe is used with a counterweight attached to it this parameter specifies the height of the counterweight. Setting: 0...PROBE_LENGTH | |
| EMPTY_AREA Empty Area | RW | Empty Area Setting: 0...PROBE_LENGTH | |
| EPSILON_R_GAS Dielectric constant of the gas | RW | A major parameter for TDR level measurement devices. If the gas above the filling medium is not air, set this value to the dielectric constant of the gas. Setting: 0.8...115 | |
| EPSILON_R_PRODUCT Dielectric constant of the product | RW | For measurement in TBF mode: Specifies the dielectric constant of the product. If possible, type in the exact value. If you do not know the exact value, use param. AUTO_EPSILON_R for automatic calculation of the exact value. A new dielectric constant that is too low will mean that level will read higher than its true value. Setting: 1...115 | |
| FULL_AREA | RW | Full Area Setting: 0...PROBE_LENGTH | |
| LEVEL_LOST Level Lost Alarm | RW | Level Lost Alarm Setting: Warning / Error | |
| LEVEL_OF_POINT_1_15 Level table | RW | Table entries 1-15 containing level values. | |
| LEVEL_OF_POINT_16_30 Level table | RW | Table entries 16-30 containing level values. | |
| LIN_TYPE Linerization Type | R | The linerization type used to describe the behavior of the sensor output. Setting: Linear with input | linear with input |
| MEASURE_THRESHOLD Measurement threshold | RW | If it is difficult to identify the level signal (for example: too many parasite signals) you can increase the threshold of the signal. A threshold of 1000 is equivalent to the amplitude of the measurement pulse. A threshold of 100 is equivalent to 10% of the amplitude of the measurement pulse. | |
| MINIMUM_LAYER Interface Minimum Layer | RW | Interface Minimum Layer | |
| OFFSET Offset | RW | Offset | |
| OVERFILL_ERROR Overfill Error | RW | Overfill Error Alarm Setting: Warning / Error | |

| Parameter DD name | Access | Description and settings | Initial Value |
|--|--------|--|---------------|
| POINTS_NUM Number of table entries | RW | Number of entries in the conversion table for mass/volume. | |
| | | Setting: 0...30 | |
| PRIMARY_VALUE_ TYPE1 Primary Value Type | R | The type of measurement represented by the primary value. For Example: Mass Flow, Absolute Pressure, Differential Temperature. | level |
| PRIMARY_VALUE_ 1 Level | | The measured level value and status of available to the Function Block. | - |
| STATUS Status | R | Digital transducers, unlike their analog versions, can detect faults that make the measurement bad or prevent the actuator from responding. This additional, valuable information will be passed along with each transmission of a data value in the form of a status attribute. | - |
| VALUE Value | R | A numerical quantity entered by a user or calculated by the algorithm. | - |
| PRIMARY_VALUE_ RANGE_1 Primary Value Range - Sensor 1 | | The High and Low range limit values, the engineering units code and the number of digits to the right of the decimal point to be used to display the Primary Value. | - |
| EU_100 max value | R | The engineering unit value which represents the upper end of range of the associated block parameter. | 100 |
| EU_0 min value | R | The engineering unit value which represents the lower end of range of the associated block parameter. | 0.0 |
| UNITS_INDEX Units Index | RW | Device Description units code index for the engineering unit descriptor for the associated block value. | m |
| | | Settings: m; cm; mm; in; ft | |
| DECIMAL Decimal | R | The number of digits to the right of the decimal point which should be used by an interface device in displaying the specified parameter. | 0 |
| PRIMARY_VALUE_ TYPE2 Primary Value Type | R | The type of measurement represented by the primary value. For Example: Mass Flow, Absolute Pressure, Differential Temperature. | distance |
| PRIMARY_VALUE_ 2 Distance | | The measured distance value and status of available to the Function Block. | - |
| STATUS Status | R | Digital transducers, unlike their analog versions, can detect faults that make the measurement bad or prevent the actuator from responding. This additional, valuable information will be passed along with each transmission of a data value in the form of a status attribute. | - |
| VALUE Value | R | A numerical quantity entered by a user or calculated by the algorithm. | - |
| PRIMARY_VALUE_ RANGE_2 Primary Value Range - Sensor 2 | | The High and Low range limit values, the engineering units code and the number of digits to the right of the decimal point to be used to display the Primary Value. | |
| EU_100 max value | R | The engineering unit value which represents the upper end of range of the associated block parameter. | 100 |
| EU_0 min value | R | The engineering unit value which represents the lower end of range of the associated block parameter. | 0.0 |

| Parameter DD name | Access | Description and settings | Initial Value |
|---|--------|--|---------------------|
| UNITS_INDEX Units Index | RW | Device Description units code index for the engineering unit descriptor for the associated block value. | m |
| | | Settings: m; cm; mm; in; ft | |
| DECIMAL Decimal | R | The number of digits to the right of the decimal point which should be used by an interface device in displaying the specified parameter. | 0 |
| PRIMARY_VALUE_3 Primary Value Type | R | The type of measurement represented by the primary value. For Example: Mass Flow, Absolute Pressure, Differential Temperature. | conversion |
| PRIMARY_VALUE_3 Conversion | | The measured conversion value and status of available to the Function Block. | |
| STATUS Status | R | Digital transducers, unlike their analog versions, can detect faults that make the measurement bad or prevent the actuator from responding. This additional, valuable information will be passed along with each transmission of a data value in the form of a status attribute. | - |
| VALUE Value | R | A numerical quantity entered by a user or calculated by the algorithm. | - |
| PRIMARY_VALUE_RANGE_3 Primary Value Range - Sensor 3 | | The High and Low range limit values, the engineering units code and the number of digits to the right of the decimal point to be used to display the Primary Value. | |
| EU_100 max value | R | The engineering unit value which represents the upper end of range of the associated block parameter. | 100 |
| EU_0 min value | R | The engineering unit value which represents the lower end of range of the associated block parameter. | 0.0 |
| UNITS_INDEX Units Index | RW | Device Description units code index for the engineering unit descriptor for the associated block value. | |
| | | Setting: kgal; L; ImpGal; m ³ ; bbl; ft ³ ; m; cm; mm; in; ft; kg, t; STon; LTon | |
| DECIMAL Decimal | R | The number of digits to the right of the decimal point which should be used by an interface device in displaying the specified parameter. | 0 |
| PRIMARY_VALUE_TYPE_4 Primary Value Type | R | The type of measurement represented by the primary value. For Example: Mass Flow, Absolute Pressure, Differential Temperature. | Conversion Distance |
| PRIMARY_VALUE_4 Conversion Distance | | The measured conversion distance value and status of available to the Function Block. | |
| STATUS Status | R | Digital transducers, unlike their analog versions, can detect faults that make the measurement bad or prevent the actuator from responding. This additional, valuable information will be passed along with each transmission of a data value in the form of a status attribute. | - |
| VALUE Value | R | A numerical quantity entered by a user or calculated by the algorithm. | - |
| PRIMARY_VALUE_RANGE_4 level range | | The High and Low range limit values, the engineering units code and the number of digits to the right of the decimal point to be used to display the Primary Value. | |
| EU_100 max value | R | The engineering unit value which represents the upper end of range of the associated block parameter. | 15.0 |

| Parameter DD name | Access | Description and settings | Initial Value |
|---|--------|---|-----------------------------------|
| EU_0 min value | R | The engineering unit value which represents the lower end of range of the associated block parameter. | 0.0 |
| UNITS_INDEX Units Index | RW | Device Description units code index for the engineering unit descriptor for the associated block value. Settings: m; cm; mm; ft; in; yd | m |
| DECIMAL Decimal | R | The number of digits to the right of the decimal point which should be used by an interface device in displaying the specified parameter. | 0 |
| PROBE_END_PULSE_TYPE Probe end pulse type | RW | Probe end pulse type Setting: Probe end disabled / emitted sign / opposite emitted sign | |
| PROBE_END_THRESHOLD Probe end threshold | RW | For measurement in TBF mode. If it is difficult to identify the probe end signal (for example: too many parasite signals) you can increase the threshold of the signal. A threshold of 1000 is equivalent to the amplitude of the measurement pulse. A threshold of 100 is equivalent to 10% of the amplitude of the measurement pulse. | |
| PROBE_LENGTH Probe Length | RW | The distance from the flange face / thread stop of the device down to the bottom end of the probe (including counterweight for cable versions). If probe length has been modified, enter the new value here. Setting: 0...40000 | |
| SECONDARY_VALUE electronic temperature | | The Electronic temperature. | |
| STATUS Status | R | Digital transducers, unlike their analog versions, can detect faults that make the measurement bad or prevent the actuator from responding. This additional, valuable information will be passed along with each transmission of a data value in the form of a status attribute. | -0 |
| VALUE Value | R | A numerical quantity entered by a user or calculated by the algorithm. | |
| SECONDARY_VALUE_UNIT electronic temperature unit | RW | The engineering units to be used with SECONDARY_VALUE (electronic temperature). Setting: K; °C; °F; °R | °C |
| SENSOR_CAL_DATE Sensor Calibration Date | R | The date of the last sensor calibration. | - |
| SENSOR_CAL_LOC Sensor Calibration Location | R | The last physical location at which the sensor was calibrated. (ex. Acme Labs) | - |
| SENSOR_CAL_METHOD Sensor Calibration method | R | The method of last sensor calibration. It could be one of the several standard calibration methods defined by ISO or some other method. | factory trim standard calibration |
| SENSOR_RANGE Sensor Range | | The High and Low range limit values, the engineering units code and the number of digits to the right of the decimal point for the sensor. | |
| EU_100 max value | R | The engineering unit value which represents the upper end of range of the associated block parameter. | |

| Parameter DD name | Access | Description and settings | Initial Value |
|--|--------|--|---------------|
| EU_0 min value | R | The engineering unit value which represents the lower end of range of the associated block parameter. | |
| UNITS_INDEX Units Index | R | Device Description units code index for the engineering unit descriptor for the associated block value. | |
| DECIMAL Decimal | R | The number of digits to the right of the decimal point which should be used by an interface device in displaying the specified parameter. | 2 |
| SENSOR_SN Sensor Serial Number | R | The sensor serial number. | |
| SENSOR_TYPE Sensor Type | R | The type of sensor. | Level |
| SENSOR_CAL_Who Sensor Calibration Who | R | The name of the person responsible for the last sensor calibration. | |
| TANK_HEIGHT Tank Height | RW | The distance from the tank connecting flange face/thread stop down to the tank bottom. Setting: 0...100000 | |
| TEMPERATURE_OUT_OF_RANGE Temperature Out of Range | RW | Temperature Out of Range Alarm Setting: Warning / Error | |
| TRACING_VELOCITY Tracing velocity | RW | This function sets the maximum rate of change of level. The measured value cannot change faster than the tracing velocity. | |
| TIME_CONST Time constant | RW | Using this function, the device processes several measurement readings to filter out disturbances. Increasing the time constant will smoothen the integrated readings, decreasing will roughen the readings. | |
| TRANSDUCER_DIRECTORY Transducer Directory Entry | | A directory that specifies the number and starting indices of the data collections in the Transducer Block. | |
| TRANSDUCER_TYPE Transducer Type | R | Identifies the transducer that follows. | Other |
| UNIT_CONVERSION unit conversion | RW | Unit used for entries in conversion table Setting: gal; L; ImpGal; m ³ ; bbl; ft ³ ; m; cm; mm; in; ft; kg; t; STon; LTon | |
| UNIT_LENGTH unit length | RW | Unit used for length parameter Setting: m; cm; mm; in; ft | |
| VOLUME_OF_POINT_1_15 Mass/volume conversion table | RW | Mass/volume values 1-15 corresponding to the entries in the level table. | |
| VOLUME_OF_POINT_16_30 Mass/volume conversion table | RW | Mass/volume values 16-30 corresponding to the entries in the level table.v | |

| Parameter DD name | Access | Description and settings | Initial Value |
|-------------------------------------|--------|--|---------------|
| XD_ERROR Transducer Error | R | One of the transducer error codes defined in section 4.7 "Block Alarm Subcodes" of the FF Transducer Specifications. Setting: Unspecified error / General error / Calibration error / Configuration error / Electronics Failure / Mechanical Failure / I/O Failure / Data Integrity Error / Software Error / Algorithm Error | Uninitialized |

4.6.2 Transducer "Display" Block

| Parameter DD name | Access | Description and settings | Initial Value |
|---------------------------------|--------|--|---------------|
| ALERT_KEY Alert Key | RW | The identification number of the plant unit. This information may be used in the host for sorting alarms, etc. Setting: 1...255 | 0 |
| BLOCK_ERR Block Error | R | This parameter reflects the error status associated with the hardware or software components associated with a block. It is a bit string, so that multiple errors may be shown. Setting: <ul style="list-style-type: none"> • Other: Non-specific error active • Block Configuration: Error detected in block configuration • Link Configuration: Error detected in link configuration • Simulation Active: Simulation enabled in this block • Local Override: Output tracking of faultstate active • Device Fault State: Device faultstate set • Device Maintenance: Device needs maintenance soon • Input Failure: Process variable has bad status • Output Failure: Failure detected in output hardware • Memory Failure: Memory error detected • Lost Static Data: Static parameters cannot be recovered • Lost NV Data: Non-volatile parameters cannot be recovered • Readback Check: Failure detected in READBACK • Maintenance Needed: Device NEEDS maintenance NOW • Power Up: Recovery from power failure • Out Of Service: Block actual mode is out of service | Other |
| MODE_BLK Block Mode | | The actual, target, permitted and normal modes of the block. | |
| TARGET Target | RW | This is the mode requested by the operator. Only one mode from those allowed by the permitted mode parameter may be requested. Setting: Auto / OOS | Auto |
| ACTUAL Actual | R | This is the current mode of the block, which may differ from the target based on operating conditions. Its value is calculated as part of block execution. Setting: Auto / OOS | Auto |
| PERMITTED Permitted | RW | Defines the modes which are allowed for an instance of the block. The permitted mode is configured based on application requirement. Setting: Auto / OOS | Auto OOS |

| Parameter DD name | Access | Description and settings | Initial Value |
|----------------------------------|--------|--|---------------|
| NORMAL Normal | RW | This is the mode which the block should be set to during normal operating conditions. Setting: Auto / OOS | Auto |
| ST_Rev Static Revision | R | The revision level of the static data associated with the function block. The revision value will be incremented each time a static parameter value in the block is changed. Setting: 0...65535 | 0 |
| STRATEGY Strategy | RW | The strategy field can be used to identify grouping of blocks. This data is not checked or processed by the block. Setting: 0...65535 | 0 |
| TAG_DESC Tag Description | RW | The user description of the intended application of the block. Setting: ≤32 digits | spaces |
| BLOCK_ALM Block Alarm | | The block alarm is used for all configuration, hardware, connection failure or system problems in the block. The cause of the alert is entered in the subcode field. The first alert to become active will set the "Active" status in the "Status" attribute. As soon as the "Unreported" status is cleared by the alert reporting task, another block alert may be reported without clearing the "Active" status, if the subcode has changed. | - |
| UNACKNOWLEDGED Unacknowledged | RW | A discrete enumeration which is set to "Unacknowledged" when an alarm occurs, and set to "Acknowledged" by a write from a human interface device or other entity which can acknowledge that the alarm/event has been noticed. Setting: Uninitialized / Acknowledged / Unacknowledged | Uninitialized |
| ALARM_STATE Alarm State | R | A discrete enumeration which gives an indication of whether the alert is active and whether it has been reported. Setting: Uninitialized / Clear - reported / Clear - not reported / Active - reported / Active - not reported | Uninitialized |
| TIME_STAMP Time Stamp | R | The time when evaluation of the block was started and a change in alarm/event state was detected that is unreported. The time stamp value will be maintained constant until alert confirmation has been received - even if another change of state occurs. Setting: MM / DD / YY (Month / Day / Year) HH:MM:SS (Hour:Minute:Second) | Uninitialized |
| SUB_CODE Subcode | R | An enumeration specifying the cause of the alert to be reported. Setting: Other / Block Configuration / Link Configuration / Simulation Active / Local Override / Device Fault State / Device Maintenance / Input Failure / Output Failure / Memory Failure / Lost Static Data / Lost NV Data / Readback Check / Maintenance Needed / Power Up / Out Of Service | Other |
| VALUE Value | R | The value of the associated parameter at the time the alert was detected. Setting: 0...255 | 0 |
| UPDATE_EVT Update Event | | This alert is generated by any change to the static data. | |

| Parameter DD name | Access | Description and settings | Initial Value |
|--|--------|--|---------------|
| UNACKNOWLEDGED Unacknowledged | RW | A discrete enumeration which is set to "Unacknowledged" when an update occurs, and set to "Acknowledged" by a write from a human interface device or other entity which can acknowledge that the alarm has been noticed. Setting: Uninitialized / Acknowledged / Unacknowledged | Uninitialized |
| UPDATE_STATE Update State | R | A discrete enumeration which gives an indication of whether the alert has been reported. Setting: Uninitialized / Update reported / Update not reported | Uninitialized |
| TIME_STAMP Time Stamp | R | The time when evaluation of the block was started and a change in alarm/event state was detected that is unreported. The time stamp value will be maintained constant until alert confirmation has been received - even if another change of state occurs. Setting: MM / DD / YY (Month / Day / Year) HH:MM:SS (Hour:Minute:Second) | Uninitialized |
| STATIC_REVISION Static Rev | R | The static revision of the block whose static parameter was changed and is being reported. It is possible for the present value of static revision to be greater than this because static can be changed at any time. Setting: 0...65535 | 0 |
| RELATIVE_INDEX Relative Index | R | The OD index of the static parameter whose change caused this alert, minus the FB starting index. If the update event was caused by a write to multiple parameters at the same time, then this attribute will be zero. Setting: 0...65535 | 0 |
| COLLECTION_ DIRECTORY Collection Directory | | A directory that specifies the number, starting indices and DD Item IDs of the data collections in each transducer within a Transducer Block. | - |
| DISPLAY_SETTING Display Setting | | Display Setting | |
| LANGUAGE Display language | R | Display language of the device display Setting: English / German / French / Italian / Spanish / Portuguese / Japanese / Chinese / Russian | |
| LENGTH_UNIT Display length unit | R | Length unit for level/distance to be shown on the device display Setting: m; cm; mm; in; ft | |
| CONVERSION_UNIT | R | Length/volume/mass conversion unit for the conversion table and to be shown on the device display Setting: m3; liter; US gal; GB gal; ft3; barrel; kg; metric ton; GB ton; US ton; m; cm; mm; inch; feet; ft3/h; m3/h | |
| SETTING_SEL Setting selector | RW | Parameter to select predefined display setting Setting: None / Setting 1 / Setting 2 | |
| SETTING_1 Display setting 1 | | Display setting 1 | |

| Parameter DD name | Access | Description and settings | Initial Value |
|---|--------|--|---------------|
| SET_LANGUAGE Display language | RW | Display language of the device display English / German / French / Italian / Spanish / Portuguese / Japanese / Chinese / Russian | |
| SET_LENGTH_UNIT Display length unit | RW | Length unit for level/distance to be shown on the device display Setting: m; cm; mm; in; ft | |
| SET_CONVERSION_U NIT Conversion unit | RW | Length/volume/mass conversion unit for the conversion table and to be shown on the device display Setting: m3; liter; US gal; GB gal; ft3; barrel; kg; metric ton; GB ton; US ton; m; cm; mm; inch; feet; ft3/h; m3/h | |
| SETTING_2 Display setting 2 | | Display setting 2 | |
| SET_LANGUAGE Display language | RW | Display language of the device display Setting: English / German / French / Italian / Spanish / Portuguese / Japanese / Chinese / Russian | |
| SET_LENGTH_UNIT Display length unit | RW | Length unit for level/distance to be shown on the device display Setting: m; cm; mm; in; ft | |
| SET_CONVERSION_ UNIT Conversion unit | RW | Length/volume/mass conversion unit for the conversion table and to be shown on the device display Setting: m3; liter; US gal; GB gal; ft3; barrel; kg; metric ton; GB ton; US ton; m; cm; mm; inch; feet; ft3/h; m3/h | |
| TRANSDUCER_ DIRECTORY Transducer Directory Entry | | A directory that specifies the number and starting indices of the data collections in the transducer block. | |
| TRANSDUCER_TYPE Transducer Type | R | Identifies the transducer that follows. | Other |
| XD_ERROR Transducer Error | R | One of the transducer error codes defined in section 4.7 "Block Alarm Subcodes" of the FF Transducer Specifications. Setting: Unspecified error / General error / Calibration error / Configuration error / Electronics Failure / Mechanical Failure / I/O Failure / Data Integrity Error / Software Error / Algorithm Error | Uninitialized |

4.6.3 Transducer "Diagnose" Block

| Parameter DD name | Access | Description and settings | Initial Value |
|----------------------------------|--------|--|---------------|
| ALERT_KEY Alert Key | RW | The identification number of the plant unit. This information may be used in the host for sorting alarms, etc. Setting: 1...255 | 0 |
| BLOCK_ERR Block Error | R | This parameter reflects the error status associated with the hardware or software components associated with a block. It is a bit string, so that multiple errors may be shown. Setting: <ul style="list-style-type: none"> • Other: Non-specific error active • Block Configuration: Error detected in block configuration • Link Configuration: Error detected in link configuration • Simulation Active: Simulation enabled in this block • Local Override: Output tracking of faultstate active • Device Fault State: Device faultstate set • Device Maintenance: Device needs maintenance soon • Input Failure: Process variable has bad status • Output Failure: Failure detected in output hardware • Memory Failure: Memory error detected • Lost Static Data: Static parameters cannot be recovered • Lost NV Data: Non-volatile parameters cannot be recovered • Readback Check: Failure detected in READBACK • Maintenance Needed: Device NEEDS maintenance NOW • Power Up: Recovery from power failure • Out Of Service: Block actual mode is out of service | Other |
| MODE_BLK Block Mode | | The actual, target, permitted and normal modes of the block. | - |
| TARGET Target | RW | This is the mode requested by the operator. Only one mode from those allowed by the permitted mode parameter may be requested. Setting: Auto / OOS | Auto |
| ACTUAL Actual | R | This is the current mode of the block, which may differ from the target based on operating conditions. Its value is calculated as part of block execution. Setting: Auto / OOS | Auto |
| PERMITTED Permitted | R/W | Defines the modes which are allowed for an instance of the block. The permitted mode is configured based on application requirement. Setting: Auto / OOS | Auto OOS |
| NORMAL Normal | R/W | This is the mode which the block should be set to during normal operating conditions. Setting: Auto / OOS | Auto |
| ST_Rev Static Revision | R | The revision level of the static data associated with the function block. The revision value will be incremented each time a static parameter value in the block is changed. Setting: 0...65535 | 0 |

| Parameter DD name | Access | Description and settings | Initial Value |
|---|--------|--|---------------|
| STRATEGY Strategy | R/W | The strategy field can be used to identify grouping of blocks. This data is not checked or processed by the block. | 0 |
| | | Setting: 0...65535 | |
| TAG_DESC Tag Description | R/W | The user description of the intended application of the block. | spaces |
| | | Setting: ≤32 digits | |
| BLOCK_ALM Block Alarm | | The block alarm is used for all configuration, hardware, connection failure or system problems in the block. The cause of the alert is entered in the subcode field. The first alert to become active will set the "Active" status in the "Status" attribute. As soon as the "Unreported" status is cleared by the alert reporting task, another block alert may be reported without clearing the "Active" status, if the subcode has changed. | - |
| UNACKNOWLEDG ED Unacknowledged | RW | A discrete enumeration which is set to "Unacknowledged" when an alarm occurs, and set to "Acknowledged" by a write from a human interface device or other entity which can acknowledge that the alarm/event has been noticed. | Uninitialized |
| | | Setting: Uninitialized / Acknowledged / Unacknowledged | |
| ALARM_STATE Alarm State | R | A discrete enumeration which gives an indication of whether the alert is active and whether it has been reported. | Uninitialized |
| | | Setting: Uninitialized / Clear - reported / Clear - not reported / Active - reported / Active - not reported | |
| TIME_STAMP Time Stamp | R | The time when evaluation of the block was started and a change in alarm/event state was detected that is unreported. The time stamp value will be maintained constant until alert confirmation has been received - even if another change of state occurs. | Uninitialized |
| | | Setting: MM / DD / YY (Month / Day / Year) HH:MM:SS (Hour:Minute:Second) | |
| SUB_CODE Subcode | R | An enumeration specifying the cause of the alert to be reported. | Other |
| | | Setting: Other / Block Configuration / Link Configuration / Simulation Active / Local Override / Device Fault State / Device Maintenance / Input Failure / Output Failure / Memory Failure / Lost Static Data / Lost NV Data / Readback Check / Maintenance Needed / Power Up / Out Of Service | |
| VALUE Value | R | The value of the associated parameter at the time the alert was detected. | 0 |
| | | Setting: 0...255 | |
| UPDATE_EVT Update Event | | This alert is generated by any change to the static data. | - |
| UNACKNOW- LEDGED Unacknowledged | R/W | A discrete enumeration which is set to "Unacknowledged" when an alarm occurs, and set to "Acknowledged" by a write from a human interface device or other entity which can acknowledge that the alarm/event has been noticed. | Uninitialized |
| | | Setting: Uninitialized / Acknowledged / Unacknowledged | |

| Parameter DD name | Access | Description and settings | Initial Value |
|--|--------|--|---------------|
| UPDATE_STATE Update State | R | A discrete enumeration which gives an indication of whether the alert has been reported. Setting: Uninitialized / Update reported / Update not reported | Uninitialized |
| TIME_STAMP Time Stamp | R | The time when evaluation of the block was started and a change in alarm/event state was detected that is unreported. The time stamp value will be maintained constant until alert confirmation has been received - even if another change of state occurs. Setting: MM / DD / YY (Month / Day / Year) HH:MM:SS (Hour:Minute:Second) | Uninitialized |
| STATIC_REVISION Static Rev | R | The static revision of the block whose static parameter was changed and is being reported. It is possible for the present value of static revision to be greater than this because static can be changed at any time. Setting: 0...65535 | 0 |
| RELATIVE_INDEX Relative Index | R | The OD index of the static parameter whose change caused this alert, minus the FB starting index. If the update event was caused by a write to multiple parameters at the same time, then this attribute will be zero. Setting: 0...65535 | 0 |
| ANALYSIS_DATA_UPDATE Analysis Data Update | RW | No help available Data to update / Start Update / Update in progress | |
| ANALYSIS_DATA_0 analysis data 0 | R | The analysis data of the device used in the DTM | |
| ANALYSIS_DATA_1 analysis data 1 | R | The analysis data of the device used in the DTM | |
| ANALYSIS_DATA_2 analysis data 2 | R | The analysis data of the device used in the DTM | |
| ANALYSIS_DATA_3 analysis data 3 | R | The analysis data of the device used in the DTM | |
| ANALYSIS_DATA_4 analysis data 4 | R | The analysis data of the device used in the DTM | |
| ANALYSIS_DATA_5 analysis data 5 | R | The analysis data of the device used in the DTM | |
| ANALYSIS_DATA_6 analysis data 6 | R | The analysis data of the device used in the DTM | |
| ANALYSIS_DATA_7 analysis data 7 | R | The analysis data of the device used in the DTM | |
| COLLECTION_DIRECTORY Collection Directory | | A directory that specifies the number, starting indices and DD Item IDs of the data collections in each transducer within a Transducer Block. | - |

| Parameter DD name | Access | Description and settings | Initial Value |
|---|--------|---|---------------|
| DIAGNOSIS_INFO diagnosis info | R | diagnosis info | |
| TEMPERATURE temperature | R | temperature | |
| CURRENT_IN_ LOOP current converter | R | Current value measured by the ADC of the converter board | |
| LOAD_CURRENT current capacitors | R | Current value which is loading the capacitors on the converter board | |
| VOLTAGE_5_6_V voltage 5.6V | R | Voltage value used by the sensor | |
| VOLTAGE_ON_C voltage capacitors | R | Voltage value on the capacitors | |
| VOLTGE_3_3_V voltage 3.3V | R | Voltage value which powers the CPU | |
| RAW_REF_PULSE _AMP Reference pulse amplitude | R | No help available | |
| RAW_LEV_PULSE _AMP Level pulse amplitude | R | Ratio of the amplitude of the TDR-pulse reflected by the filling material to the reference amplitude. | |
| RAW_PROBE_END PULSE_AMP Probe end pulse amplitude | R | Ratio of the amplitude of the TDR-pulse reflected by the probe end to the reference amplitude. | |
| RESET_COUNTER Reset Counter | R | No help available | |
| EPSILON_R Auto Epsilon R Calculation | | Auto Epsilon R Calculation | |
| DIELECTRIC_CST_ RAW Epsilon R Calculated | R | Epsilon R Calculated | |
| PULSES_INFO TDR-pulse information | | | |
| DISTANCE_VALUE _UNIT Distance value unit | R | No help available | |
| DISTANCE_VALUE Distance value | R | No help available | |
| REF_PULSE_AMP Reference pulse amplitude | R | No help available | |
| LEV_PULSE_AMP Level pulse amplitude | R | Ratio of the amplitude of the TDR-pulse reflected by the filling material to the reference amplitude. | |
| PROBE_END_PUL SE_AMP Probe end pulse amplitude | R | Ratio of the amplitude of the TDR-pulse reflected by the probe end to the reference amplitude. | |
| STATUS_INFO status info | | status info | |

| Parameter DD name | Access | Description and settings | Initial Value |
|---|--------|--|---------------|
| HARDWARE_ ERROR Hardware error | R | Hardware error | |
| | | Setting: Converter EEPROM error / Converter RAM error / Converter ROM error / Sensor EEPROM error / Sensor RAM error / Sensor ROM error / not defined / Oscillator Frequency failure | |
| VOLTAGE_ERROR Hardware error | R | Hardware error | |
| | | Setting: Converter Voltage error / Sensor Voltage error / Internal Communication error / Temperature out of range / Sensor version not compatible / not defined | |
| PULSE_ERROR Hardware error | R | Hardware error | |
| | | Setting: Reference Pulse Lost / Level Pulse Lost / not defined / Overfill Error / No Probe Detected / not defined | |
| WARNING_MAINT ENANCE Warning (Maintenance required) | R | Warning (Maintenance required) | |
| | | Setting: Flange Pulse Lost / not defined / Snapshot not valid / Reference Position Outside Range / Audio Signal Offset Outside Range / Temperature Below -35°C / Temperature Above +75°C | |
| WARNING_OUT_ OF_SPEC Warning (Out of Specifications) | R | Warning (Out of Specifications) | |
| INFORMATIONAL Information | R | Information | |
| | | Setting: First Start / Epsilon R Calculation Frozen / Epsilon R value low / Epsilon R value high / Temperature outside operating range of Local Display / not defined | |
| TRANSDUCER_ DIRECTORY Transducer Directory Entry | R | A directory that specifies the number and starting indices of the data collections in the Transducer Block. | |
| TRANSDUCER_ TYPE Transducer Type | R | Identifies the transducer that follows. | Other |
| XD_ERROR Transducer Error | R | One of the transducer error codes defined in section 4.7 "Block Alarm Subcodes" of the FF Transducer Specifications. | Uninitialized |
| | | Setting: Unspecified error / General error / Calibration error / Configuration error / Electronics Failure / Mechanical Failure / I/O Failure / Data Integrity Error / Software Error / Algorithm Error | |

4.7 Proportional Integral Derivative Block (PID)

The following tables list the PID Block parameters in alphabetical order.

The following tables contain short parameter description, factory settings (Initial Value (IV)) and possible settings.

| Parameter DD name | Access | Description and settings | Initial Value |
|---------------------------------|--------|--|-----------------------------------|
| ALERT_KEY Alert Key | R/W | The identification number of the plant unit. This information may be used in the host for sorting alarms, etc. Setting: 1...255 | 1 |
| BLOCK_ERR Block Error | R | This parameter reflects the error status associated with the hardware or software components associated with a block. It is a bit string, so that multiple errors may be shown. Setting: <ul style="list-style-type: none"> • Other: Non-specific error active • Block Configuration: Error detected in block configuration • Simulation Active: Simulation enabled in this block • Local Override: Output tracking of faultstate active • Device Fault State: Device faultstate set • Device Maintenance: Device needs maintenance soon • Input Failure: Process variable has bad status • Output Failure: Failure detected in output hardware • Memory Failure: Memory error detected • Lost Static Data: Static parameters cannot be recovered • Lost NV Data: Non-volatile parameters cannot be recovered • Readback Check: Failure detected in READBACK • Maintenance Needed: Device NEEDS maintenance NOW • Power Up: Recovery from power failure • Out Of Service: Block actual mode is out of service | Current Block Error |
| MODE_BLK Block Mode | Mix | The actual, target, permitted and normal modes of the block. | - |
| TARGET Target | R/W | This is the mode requested by the operator. Only one mode from those allowed by the permitted mode parameter may be requested. Setting: ROut / RCas / Cas / Auto / Man / OOS | OOS |
| ACTUAL Actual | R | This is the current mode of the block, which may differ from the target based on operating conditions. Its value is calculated as part of block execution. Setting: ROut / RCas / Cas / Auto / Man / OOS | Actual mode |
| PERMITTED Permitted | R/W | Defines the modes which are allowed for an instance of the block. The permitted mode is configured based on application requirement. Setting: ROut / RCas / Cas / Auto / Man / OOS | ROut, RCas, Cas, Auto, Man or OOS |
| NORMAL Normal | R/W | This is the mode the block should be set to during normal operating conditions. Setting: Auto | Auto |

| Parameter DD name | Access | Description and settings | Initial Value |
|--|--------|--|--------------------|
| ST_REV Static Revision | R | The revision level of the static data associated with the function block. The revision value will be incremented each time a static parameter value in the block is changed. | 0 |
| | | Setting: 0...65535 | |
| STRATEGY Strategy | R/W | This parameter can be used to create groups of blocks by control system. This data is not checked or processed by the block. | 0 (=uninitialized) |
| | | Setting: 0...65535 | |
| TAG_DESC Tag Description | R/W | The user description of the intended application of the block. | spaces |
| | | Setting: ≤32 digits | |
| ACK_OPTION Acknowledge Option | R/W | Selection of whether alarms associated with the function block will be automatically acknowledged. | No option selected |
| | | Setting: <ul style="list-style-type: none"> • HiHi Alm Disabled: HiHi alarm disabled • Hi Alm Disabled: Hi alarm disabled • LoLo Alm Disabled: LoLo alarm disabled • Lo Alm Disabled: Lo alarm disabled • DevHi Alm Disabled: Deviation Hi alarm disabled • DevLo Alm Disabled: Deviation Lo alarm disabled • Block Alm Disabled: Block alarm disabled | |
| ALARM_HYS Alarm Hysteresis | R/W | Amount the PV must return within the alarm limits before the alarm condition clears. Alarm hysteresis expressed as a percent of the span of the PV. | 0.5 |
| | | Setting: 0.0...50.0% | |
| ALARM_SUM Alarm Summary | Mix | The current alert status, unacknowledged states, unreported states and disabled states of the alarms associated with the function block. | - |
| Current | R | Setting: HiHi Alm Active / Hi Alm Active / LoLo Alm Active / Lo Alm Active / DevHi Alarm Active / DevLo Alm Active / Block Alm Active | Uninitialized |
| Unacknowledged | R | Setting: HiHi Alm Unack / Hi Alm Unack / LoLo Alm Unack / Lo Alm Unack / DevHi Alarm Unack / DevLo Alm Unack / Block Alm Unack | Uninitialized |
| Unreported | R | Setting: HiHi Alm Unrep / Hi Alm Unrep / LoLo Alm Unrep / Lo Alm Unrep / DevHi Alarm Unrep / DevLo Alm Unrep / Block Alm Unrep | Uninitialized |
| Disabled | R | Setting: HiHi Alm Disabled / Hi Alm Disabled / LoLo Alm Disabled / Lo Alm Disabled / DevHi Alarm Disabled / DevLo Alm Disabled / Block Alm Disabled | Uninitialized |
| BAL_TIME Balance Time | R/W | This specifies the time for the internal working value of bias or ratio to return to the operator set bias or ratio, in seconds. In the PID block, it may be used to specify the time constant at which the integral term will move to obtain balance when the output is limited and the mode is Auto, Cas or RCas. | 0 |
| | | Setting: 0.0 s | |

| Parameter DD name | Access | Description and settings | Initial Value |
|--|--------|--|---------------|
| BKCAL_HYS Back Calculation Hysteresis | R/W | Limits the minimum output value for modes other than "Manual". The limit status is turned off, expressed as a percent of the span of the output. | 0.5 |
| | | Setting: 0.0...50.0% | |
| BKCAL_IN Back Calculation Input | R/W | The value and status used for backwards tracking of the output, provided by a link to the back calculation output parameter of a downstream block. | - |
| Status | R/W | Status of BKCAL_IN | - |
| Value | R/W | Value of BKCAL_IN | - |
| BKCAL_IN Back Calculation Input | R | The output value and status provided to an upstream block for output tracking when the loop is broken or limited, as determined by the status bits. This information is used to provide bumpless transfer to closed loop control and to prevent windup under limited conditions when that becomes possible. | - |
| | | Status | |
| Value | R | Value of BKCAL_OUT | - |
| BLOCK_ALM Block Alarm | R/W | The block alarm is used for all configuration, hardware, connection failure or system problems in the block. The cause of the alert is entered in the subcode field. The first alert to become active will set the "Active" status in the "Status" attribute. As soon as the "Unreported" status is cleared by the alert reporting task, another block alert may be reported without clearing the "Active" status, if the subcode has changed. | - |
| Unacknowledged | R/W | A discrete enumeration which is set to "Unacknowledged" when an alarm occurs, and set to "Acknowledged" by a write from a human interface device or other entity which can acknowledge that the alarm/event has been noticed. | Uninitialized |
| | | Setting: Uninitialized / Acknowledged / Unacknowledged | |
| Alarm State | R | A discrete enumeration which gives an indication of whether the alert is active and whether it has been reported. | Uninitialized |
| | | Setting: <ul style="list-style-type: none"> • Uninitialized • Clear - reported: Alarm not active and reported • Clear - not reported: Alarm not active and not reported • Active - reported: Alarm active and reported • Active - not reported: Alarm active and not reported | |
| Time Stamp | R | The time when evaluation of the block was started and a change in alarm/event state was detected that is unreported. The time stamp value will be maintained constant until alert confirmation has been received - even if another change of state occurs. | Uninitialized |
| | | Setting: MM / DD / YY (Month / Day / Year) HH:MM:SS (Hour:Minute:Second) | |

| Parameter DD name | Access | Description and settings | Initial Value |
|-----------------------------|--------|---|---------------|
| Subcode | R | An enumeration specifying the cause of the alert to be reported. Setting: <ul style="list-style-type: none"> Other: Non-specific error active BlockConfiguration: Error detected in block configuration LinkConfiguration: Error detected in link configuration SimulationActive: Simulation enabled in this block LocalOverride: Output tracking or faultstate active DeviceFaultState: DeviceFaultState DeviceMaintenance: Device needs maintenance soon InputFailure: Process variable has bad status OutputFailure: Failure detected in output hardware MemoryFailure: Memory error detected LostStaticData: Static parameters cannot be recovered LostNVData: Non-Volatile parameters cannot be recovered ReadbackCheck: Failure detected in READBACK MaintenanceNeeded: Device NEEDS maintenance NOW PowerUp: Recovery from power failure OutOfService: Block actual mode is Out of Service | Other |
| Value | R | The value of the associated parameter at the time the alert was detected. Setting: 0...255 | 0 |
| BYPASS Bypass | R/W | The normal control algorithm may be bypassed through this parameter. When bypass is set, the setpoint value (in percent) will be directly transferred to the output. To prevent a bump on transfer to/from bypass, the setpoint will automatically be initialized to the output value or process variable, respectively, and the path broken flag will be set for one execution. Setting: <ul style="list-style-type: none"> ON: normal control algorithm bypassed, output based on setpoint OFF: normal control | Uninitialized |
| CAS_IN Cascade Input | R/W | This parameter is the remote setpoint value, which must come from another Fieldbus block or a DCS block through a defined link. | - |
| Status | R/W | Status of CAS_IN | - |
| Value | R/W | Value of CAS_IN | - |

| Parameter DD name | Access | Description and settings | Initial Value |
|--|--------|---|--------------------|
| CONTROL_OPTS Control Options | R/W | Options which the user may select to alter the calculations done in a control block. Setting: <ul style="list-style-type: none"> • Bypass Enable: This parameter, if true, allows BYPASS to be set. Some control algorithms cannot provide closed loop control if bypassed. • SP-PV Track Man: Permits the setpoint to track the process variable when the block mode is "Man". • SP-PV Track ROut: Permits the setpoint to track the process variable when the block mode is "ROut". • SP-PV Track LO-IMan: Permits the setpoint to track the process variable when the block mode is "LO or IMan". • SP Track retain: Permits the setpoint to track the RCas or Cas parameter based on the retained target mode when the actual mode of the block is "Man, LO, Man, or Rout". • Direct acting: Defines the relationship between changes in PV and changes to output - when direct is selected, an increase in PV results in an increase in the output. • Track enable: This enables the external tracking function – when TRK_ENA is 1, the preset value in TRK_VAL is output if TRK_IN_D becomes true. • Track in manual: This is used only if TRK_ENA is YES (1) - when the block mode is Man, TRK_IN_D will be acted on only if the TRK_OVMAN control option is set. • PV for BKCal_Out: The BKCAL_OUT value may be selected as the working SP or the PV - normally, BKCAL_OUT is the working SP. • Restrict SP to limits in Cas and RCas: If this option is selected, the setpoint will be restricted to the setpoint absolute and rate limits in Cas and Rcas modes. • No output limits in Man: Do not apply OUT_HI_LIM or OUT_LO_LIM when target and actual modes are "Man". | No option selected |
| DV_HI_ALM Deviation High Alarm | Mix | The status and time stamp associated with the high deviation alarm. | - |
| Unacknowledged | R/W | A discrete enumeration which is set to "Unacknowledged" when an alarm occurs, and set to "Acknowledged" by a write from a human interface device or other entity which can acknowledge that the alarm/event has been noticed. Setting: Uninitialized / Acknowledged / Unacknowledged | Uninitialized |
| Alarm State | R | A discrete enumeration which gives an indication of whether the alert is active and whether it has been reported. Setting: <ul style="list-style-type: none"> • Uninitialized • Clear - reported: Alarm not active and reported • Clear - not reported: Alarm not active and not reported • Active - reported: Alarm active and reported • Active - not reported: Alarm active and not reported | Uninitialized |
| Time Stamp | R | The time when evaluation of the block was started and a change in alarm/event state was detected that is unreported. The time stamp value will be maintained constant until alert confirmation has been received - even if another change of state occurs. Setting: MM / DD / YY (Month / Day / Year) HH:MM:SS (Hour:Minute:Second) | Uninitialized |

| Parameter DD name | Access | Description and settings | Initial Value |
|---|--------|---|---------------|
| Subcode | R | An enumeration specifying the cause of the alert to be reported. | Other |
| | | Setting: Settings see above parameter "BLOCK_ALM", subelement "Subcode". | |
| Value | R | The value of the associated parameter at the time the alert was detected. | 0 |
| | | Setting: 0...255 | |
| DV_HI_LIM Deviation High Limit | R/W | The setting of the high deviation alarm limit in engineering units. | +INF |
| DV_HI_PRI Deviation High Priority | R/W | Priority of the high deviation alarm. | 0 |
| | | Setting: 0...15 | |
| DV_LO_ALM Deviation Low Alarm | Mix | The status and time stamp associated with the low deviation alarm. | - |
| Unacknowledged | R/W | A discrete enumeration which is set to "Unacknowledged" when an alarm occurs, and set to "Acknowledged" by a write from a human interface device or other entity which can acknowledge that the alarm/event has been noticed. | Uninitialized |
| | | Setting: Uninitialized / Acknowledged / Unacknowledged | |
| Alarm State | R | A discrete enumeration which gives an indication of whether the alert is active and whether it has been reported. | Uninitialized |
| | | Setting: <ul style="list-style-type: none"> • Uninitialized • Clear - reported: Alarm not active and reported • Clear - not reported: Alarm not active and not reported • Active - reported: Alarm active and reported • Active - not reported: Alarm active and not reported | |
| Time Stamp | R | The time when evaluation of the block was started and a change in alarm/event state was detected that is unreported. The time stamp value will be maintained constant until alert confirmation has been received - even if another change of state occurs. | Uninitialized |
| | | Setting: MM / DD / YY (Month / Day / Year) HH:MM:SS (Hour:Minute:Second) | |
| Subcode | R | An enumeration specifying the cause of the alert to be reported. | Other |
| | | Setting: Settings see above parameter "BLOCK_ALM", subelement "Subcode". | |
| Value | R | The value of the associated parameter at the time the alert was detected. | 0 |
| | | Setting: 0...255 | |
| DV_LO_LIM Deviation Low Limit | R/W | The setting of the low deviation alarm limit in engineering units. | -INF |
| DV_LO_PRI Deviation Low Priority | R/W | Priority of the low deviation alarm. | 0 |
| | | Setting: 0...15 | |

| Parameter DD name | Access | Description and settings | Initial Value |
|---------------------------------------|--------|--|--------------------|
| FF_GAIN Feed Forward Gain | R/W | The gain that the feed forward input is multiplied by before it is added to the calculated control output. | 0 |
| FF_SCALE Feed Forward Scale | R/W | The feed forward input high and low scale values, engineering units code and number of digits to the right of the decimal point. | - |
| EU at 100% | R/W | The engineering unit value which represents the upper end of range of the associated block parameter. | 100 |
| EU at 0% | R/W | The engineering unit value which represents the lower end of range of the associated block parameter. | 0 |
| Units Index | R/W | Device Description units code index for the engineering unit descriptor for the associated block value. Setting: All units are possible. | Uninitialized |
| FF_VAL Feed Forward Value | R | The feed forward value and status. | - |
| Status | R | Status of FF_VAL | - |
| Value | R | Value of FF_VAL | - |
| GAIN Gain | R/W | Dimensionless value used by the block algorithm in calculating the block output. | 0 |
| GRANT_DENY Grant Deny | R/W | Options for controlling access of host computers and local control panels to operating, tuning and alarm parameters of the block. | - |
| Grant | R/W | Depending on the philosophy of the plant, the operator or a higher level device (HLD), or a local operator's panel (LOP) in the case of Local, may turn on an item of the Grant attribute - Program, Tuning, Alarm or Local. Setting: <ul style="list-style-type: none"> • Program: Host may change mode, setpoint or output of block • Tune: Host may change the tuning parameters of block • Alarm: Host may change the alarm parameters of block • Local: A local panel or handheld device may change the target mode, setpoint or output | No option selected |
| Deny | R/W | The "Denied" attribute is provided for use by a monitoring application in an interface device and may not be changed by an operator. Setting: <ul style="list-style-type: none"> • Program denied: Granting of program permission has been reset • Tune denied: Granting of tune permission has been reset • Alarm denied: Granting of alarm permission has been reset • Local denied: Granting of local permission has been reset | No option selected |
| HI_ALM High Alarm | Mix | The status for High Alarm and its associated time stamp. | - |
| Unacknowledged | R/W | A discrete enumeration which is set to "Unacknowledged" when an alarm occurs, and set to "Acknowledged" by a write from a human interface device or other entity which can acknowledge that the alarm/event has been noticed. Setting: Uninitialized / Acknowledged / Unacknowledged | Uninitialized |

| Parameter DD name | Access | Description and settings | Initial Value |
|-------------------------------------|--------|---|---------------|
| Alarm State | R | A discrete enumeration which gives an indication of whether the alert is active and whether it has been reported. | Uninitialized |
| | | Setting: <ul style="list-style-type: none"> • Uninitialized • Clear - reported: Alarm not active and reported • Clear - not reported: Alarm not active and not reported • Active - reported: Alarm active and reported • Active - not reported: Alarm active and not reported | |
| Time Stamp | R | The time when evaluation of the block was started and a change in alarm/event state was detected that is unreported. The time stamp value will be maintained constant until alert confirmation has been received - even if another change of state occurs. | Uninitialized |
| | | Setting: MM / DD / YY (Month / Day / Year) HH:MM:SS (Hour:Minute:Second) | |
| Subcode | R | An enumeration specifying the cause of the alert to be reported. | Other |
| | | Setting: Settings see above parameter "BLOCK_ALM", subelement "Subcode". | |
| Value | R | The value of the associated parameter at the time the alert was detected. | 0 |
| HI_HI_ALM High High Alarm | Mix | The status for High High Alarm and its associated time stamp. | - |
| Unacknowledged | R/W | A discrete enumeration which is set to "Unacknowledged" when an alarm occurs, and set to "Acknowledged" by a write from a human interface device or other entity which can acknowledge that the alarm/event has been noticed. | Uninitialized |
| | | Setting: Uninitialized / Acknowledged / Unacknowledged | |
| Alarm State | R | A discrete enumeration which gives an indication of whether the alert is active and whether it has been reported. | Uninitialized |
| | | Setting: <ul style="list-style-type: none"> • Uninitialized • Clear - reported: Alarm not active and reported • Clear - not reported: Alarm not active and not reported • Active - reported: Alarm active and reported • Active - not reported: Alarm active and not reported | |
| Time Stamp | R | The time when evaluation of the block was started and a change in alarm/event state was detected that is unreported. The time stamp value will be maintained constant until alert confirmation has been received - even if another change of state occurs. | Uninitialized |
| | | Setting: MM / DD / YY (Month / Day / Year) HH:MM:SS (Hour:Minute:Second) | |
| Subcode | R | An enumeration specifying the cause of the alert to be reported. | Other |
| | | Setting: Settings see above parameter "BLOCK_ALM", subelement "Subcode". | |
| Value | R | The value of the associated parameter at the time the alert was detected. | 0 |

| Parameter DD name | Access | Description and settings | Initial Value |
|--|--------|---|---------------|
| HI_HI_LIM High High Limit | R/W | The setting for High High Alarm in engineering units. | +INF |
| HI_HI_PRI High High Priority | R/W | Priority of the High High Alarm. | 0 |
| | | Setting: 0...15 | |
| HI_LIM High Limit | R/W | The High Limit imposed on the PV compensation term. | +INF |
| HI_PRI High Priority | R/W | Priority of the High Alarm. | 0 |
| | | Setting: 0...15 | |
| IN Input | R/W | Primary input value of the block, required for blocks that filter the input to get the PV. | - |
| Status | R/W | Status of IN | - |
| Value | R/W | Value of IN | - |
| LO_ALM Low Alarm | Mix | The status for Low Alarm and its associated time stamp. | - |
| Unacknowledged | R/W | A discrete enumeration which is set to "Unacknowledged" when an alarm occurs, and set to "Acknowledged" by a write from a human interface device or other entity which can acknowledge that the alarm/event has been noticed. | Uninitialized |
| | | Setting: Uninitialized / Acknowledged / Unacknowledged | |
| Alarm State | R | A discrete enumeration which gives an indication of whether the alert is active and whether it has been reported. | Uninitialized |
| | | Setting: <ul style="list-style-type: none"> • Uninitialized • Clear - reported: Alarm not active and reported • Clear - not reported: Alarm not active and not reported • Active - reported: Alarm active and reported • Active - not reported: Alarm active and not reported | |
| Time Stamp | R | The time when evaluation of the block was started and a change in alarm/event state was detected that is unreported. The time stamp value will be maintained constant until alert confirmation has been received - even if another change of state occurs. | Uninitialized |
| | | Setting: MM / DD / YY (Month / Day / Year) HH:MM:SS (Hour:Minute:Second) | |
| Subcode | R | An enumeration specifying the cause of the alert to be reported. | Other |
| | | Setting: Settings see above parameter "BLOCK_ALM", subelement "Subcode". | |
| Value | R | The value of the associated parameter at the time the alert was detected. | 0 |
| LO_LIM Low Limit | R/W | The setting for Low Alarm in engineering units. | -INF |
| LO_LO_ALM Low Low Alarm | Mix | The status of the Low Low Alarm and its associated time stamp. | - |

| Parameter DD name | Access | Description and settings | Initial Value |
|--|--------|--|---------------|
| Unacknowledged | R/W | A discrete enumeration which is set to "Unacknowledged" when an alarm occurs, and set to "Acknowledged" by a write from a human interface device or other entity which can acknowledge that the alarm/event has been noticed. Setting: Uninitialized / Acknowledged / Unacknowledged | Uninitialized |
| Alarm State | R | A discrete enumeration which gives an indication of whether the alert is active and whether it has been reported. Setting: <ul style="list-style-type: none"> • Uninitialized • Clear - reported: Alarm not active and reported • Clear - not reported: Alarm not active and not reported • Active - reported: Alarm active and reported • Active - not reported: Alarm active and not reported | Uninitialized |
| Time Stamp | R | The time when evaluation of the block was started and a change in alarm/event state was detected that is unreported. The time stamp value will be maintained constant until alert confirmation has been received - even if another change of state occurs. Setting: MM / DD / YY (Month / Day / Year) HH:MM:SS (Hour:Minute:Second) | Uninitialized |
| Subcode | R | An enumeration specifying the cause of the alert to be reported. Setting: Settings see above parameter "BLOCK_ALM", subelement "Subcode". | Other |
| Value | R | The value of the associated parameter at the time the alert was detected. | 0 |
| LO_LO_LIM Low Low Limit | R/W | The setting for Low Low Alarm in engineering units. | -INF |
| LO_LO_PRI Low Low Priority | R/W | Priority of the Low Low Alarm. Setting: 0...15 | 0 |
| LO_PRI Low Priority | R/W | Priority of the Low Alarm. Setting: Max. 15 | 1 |
| OUT Output | Mix | The primary analog value calculated as a result of executing the function block. | - |
| Status | R/W | Status of OUT | - |
| Value | R/W | Value of OUT | - |
| OUT_HI_LIM Output High Limit | R/W | Limits the maximum output value for modes other than "Manual". | 100 |
| OUT_LO_LIM Output Low Limit | R/W | Limits the minimum output value for modes other than "Manual". | 0 |
| OUT_SCALE Output Scale | R/W | The high and low scale values, engineering units code and number of digits to the right of the decimal point to be used in displaying the OUT parameter and parameters which have the same scaling as OUT. | - |
| EU at 100% | R/W | The engineering unit value which represents the upper end of range of the associated block parameter. | 100 |
| EU at 0% | R/W | The engineering unit value which represents the lower end of range of the associated block parameter. | 0 |

| Parameter DD name | Access | Description and settings | Initial Value |
|---|--------|--|---------------|
| Units Index | R/W | Device Description units code index for the engineering unit descriptor for the associated block value. Setting: All units are possible. | Uninitialized |
| Decimal Point | R/W | The number of digits to the right of the decimal point which should be used by an interface device in displaying the specified parameter. | 0 |
| PV Process Value | R | This alert is generated by any change to the static data. | - |
| Status | R | Status of PV | - |
| Value | R | Value of PV | - |
| PV_FT PV F Time (Process Value Filter Time Constant) | R/W | Time constant of a single exponential filter for the PV, in seconds. Setting: 0.0...30.0 | 0 |
| PV_SCALE Process Value Scale | R/W | The high and low scale values, engineering units code and number of digits to the right of the decimal point to be used in displaying the PV parameter and parameters which have the same scaling as PV. | - |
| EU at 100% | R/W | The engineering unit value which represents the upper end of range of the associated block parameter. | 100 |
| EU at 0% | R/W | The engineering unit value which represents the lower end of range of the associated block parameter. | 0 |
| Units Index | R/W | Device Description units code index for the engineering unit descriptor for the associated block value. Setting: All units are possible. | Uninitialized |
| Decimal Point | R/W | The number of digits to the right of the decimal point which should be used by an interface device in displaying the specified parameter. | 0 |
| RATE Rate | R/W | Defines the derivative time constant, in seconds. | 0 |
| RCAS_IN Remote Cascade Input | R | Target setpoint and status provided by a supervisory host to a analog control or output block. | - |
| Status | R | Status of RCAS_IN | - |
| Value | R | Value of RCAS_IN | - |
| RCAS_OUT Remote Cascade Output | R | Block setpoint and status after ramping - provided to a supervisory host for back calculation and to allow action to be taken under limiting conditions or mode change. | - |
| Status | R | Status of RCAS_OUT | - |
| Value | R | Value of RCAS_OUT | - |
| RESET Reset | R/W | The integral time constant, in seconds per repeat. | +INF |
| ROUT_IN Remote Out Input | R | Target output and status provided by a host to the control block for use as the output (ROut mode). | - |
| Status | R | Status of ROUT_IN | - |
| Value | R | Value of ROUT_IN | - |
| ROUT_OUT Remote Out Output | R | Block output and status - provided to a host for back calculation in ROut mode and to allow action to be taken under limited conditions or mode change. | - |
| Status | R | Status of ROUT_OUT | - |

| Parameter DD name | Access | Description and settings | Initial Value |
|---|--------|---|---------------|
| Value | R | Value of ROUT_OUT | - |
| SHED_OPT Shed Options | R/W | <p>Defines action to be taken on remote control device timeout.</p> <p>Setting:</p> <ul style="list-style-type: none"> Uninitialized NormalShed_NormalReturn: Actual mode changes to next lowest priority non-remote mode permitted, but returns to target remote mode after communications are re-established NormalShed_NoReturn: Target mode changes to next lowest priority non-remote mode permitted ShedToAuto_NormalReturn: Actual mode changes to "Auto", but returns to target remote mode after communications are re-established ShedToAuto_NoReturn: Target mode changes to "Auto" ShedToManual_NormalReturn: Actual mode changes to "Manual", but returns to target remote mode after communications are re-established NormalShed_NoReturn: Target mode changes to next lowest priority non-remote mode permitted ShedToRetainedTarget_NormalReturn: Shed to previous target mode and return target remote mode after communications are re-established ShedToRetainedTarget_NoReturn: Target mode changes to target retained mode | Uninitialized |
| SP Setpoint | R/W | Setpoint | 0 |
| Status | | Status of SP | |
| Value | | Value of SP | |
| SP_HI_LIM Setpoint High Limit | R/W | The setpoint high limit is the highest setpoint operator entry that can be used for the block. | 100 |
| SP_LO_LIM Setpoint Low Limit | R/W | The setpoint low limit is the highest setpoint operator entry that can be used for the block. | 0 |
| SP_RATE_DN Setpoint Rate Down | R/W | <p>Ramp rate at which downward setpoint changes are acted on in "Auto" mode, in PV units per second. If the ramp rate is set to zero or the block is in a mode other than "Auto", then the setpoint will be used immediately.</p> <p>Setting: 0.0...+INF</p> | +INF |
| SP_RATE_UP Setpoint Rate Up | R/W | <p>Ramp rate at which upward setpoint changes are acted on in "Auto" mode, in PV units per second. If the ramp rate is set to zero or the block is in a mode other than "Auto", then the setpoint will be used immediately.</p> <p>Setting: 0.0...+INF</p> | +INF |

| Parameter DD name | Access | Description and settings | Initial Value |
|---|--------|--|--------------------|
| STATUS_OPTS Status Options | R/W | Options which the user may select in the block processing of status. Setting: <ul style="list-style-type: none"> • IFS if Bad IN: Set Initiate Fault State status in OUT if the status of IN is "Bad". • IFS if Bad CAS_IN: Set Initiate Fault State status in OUT if the status of CAS_IN is "Bad". • Use Uncertain as Good: If the status of IN is "Uncertain", treat it as "Good" otherwise treat it as "Bad". • Target to Man if Bad IN: Set the target mode to "Man" if the status of the IN parameter is "Bad". This latches a PID block into the "Man" state of the input ever goes "Bad". • Target to next permitted mode if BAD CAS_IN | No option selected |
| TRK_IN_D Tracking Input Discrete | R/W | This discrete input is used to initiate external tracking of the block output to the value specified by TRL_VAL. | - |
| Status | R/W | Status of TRK_IN_D | - |
| Value | R/W | Value of TRK_IN_D | - |
| TRK_SCALE Tracking Scale | R/W | The high and low scale values, engineering units code and number of digits to the right of the decimal point associated with TRK_VAL. | - |
| EU at 100% | R/W | The engineering unit value which represents the upper end of range of the associated block parameter. | 100 |
| EU at 0% | R/W | The engineering unit value which represents the lower end of range of the associated block parameter. | 0 |
| Units Index | R/W | Device Description units code index for the engineering unit descriptor for the associated block value. Setting: All units are possible. | Uninitialized |
| Decimal Point | R/W | The number of digits to the right of the decimal point which should be used by an interface device in displaying the specified parameter. | 0 |
| TRK_VALUE Tracking Value | R/W | This input is used as the track value when external tracking is enabled by TRK_IN_D. | - |
| Status | R/W | Status of TRK_VAL | - |
| Value | R/W | Value of TRK_VAL | - |
| UPDATE_EVT Update Event | R | This alert is generated by any change to the static data. | - |
| Unacknowledged | R | A discrete enumeration which is set to "Unacknowledged" when an alarm occurs, and set to "Acknowledged" by a write from a human interface device or other entity which can acknowledge that the alarm/event has been noticed. Setting: Uninitialized / Acknowledged / Unacknowledged | Uninitialized |
| Update State | R | A discrete enumeration which gives an indication of whether the alert has been reported. Setting: Uninitialized / Reported / Not Reported | Uninitialized |

| Parameter DD name | Access | Description and settings | Initial Value |
|----------------------|--------|---|---------------|
| Time Stamp | R | <p>The time when evaluation of the block was started and a change in alarm/event state was detected that is unreported. The time stamp value will be maintained constant until alert confirmation has been received - even if another change of state occurs.</p> <p>Setting: MM / DD / YY (Month / Day / Year) HH:MM:SS (Hour:Minute:Second)</p> | Uninitialized |
| Static Revision | R | The static revision of the block whose static parameter was changed and is being reported. It is possible for the present value of static revision to be greater than this because static can be changed at any time. | 0 |
| Relative Index | R | The OD index of the static parameter whose change caused this alert, minus the FB starting index. If the update event was caused by a write to multiple parameters at the same time, then this attribute will be zero. | 0 |







KROHNE – Process instrumentation and measurement solutions

- Flow
- Level
- Temperature
- Pressure
- Process Analysis
- Services

Head Office KROHNE Messtechnik GmbH
Ludwig-Krohne-Str. 5
47058 Duisburg (Germany)
Tel.: +49 203 301 0
Fax: +49 203 301 10389
info@krohne.com

The current list of all KROHNE contacts and addresses can be found at:
www.krohne.com

KROHNE