



OPTIFLEX 2200 C/F Supplementary Instructions

Guided Radar (TDR) Level Transmitter for storage and process applications

Supplementary Instructions for NEPSI applications



1	General safety information	4
<hr/>		
1.1	Scope of the document	4
1.2	Device description	4
1.3	Standards and approvals.....	4
1.4	Equipment protection levels (EPL) and dust zones	5
1.4.1	Ex ia and Ex iaD-approved devices	5
1.4.2	Ex d ia and Ex iaD tD-approved devices	5
1.5	NEPSI nameplates.....	6
2	Installation	8
<hr/>		
2.1	Precautions.....	8
2.1.1	General notes.....	8
2.1.2	Electrostatic discharge.....	8
2.2	Operating conditions	10
2.2.1	Ambient and flange temperature	10
2.2.2	Maximum surface temperature of the housing for dust applications	16
2.2.3	Process pressure.....	16
3	Electrical connections	17
<hr/>		
3.1	General notes	17
3.2	Terminal compartment	17
3.2.1	How to open the terminal compartment	17
3.2.2	How to close the terminal compartment	19
3.3	Terminal tightening capacity.....	19
3.4	Equipotential bonding system	20
3.5	Ex ia and Ex iaD equipment.....	21
3.5.1	How to connect the electrical cables	21
3.5.2	Maximum intrinsically-safe values for the electrical circuit	21
3.5.3	Supply voltage	21
3.5.4	Electrical schematic	22
3.6	Ex d ia and Ex iaD tD equipment	23
3.6.1	General notes.....	23
3.6.2	How to connect the electrical cables	24
3.6.3	Supply voltage	24
3.6.4	Electrical schematic	24
4	Start-up	26
<hr/>		
5	Service	27
<hr/>		
5.1	Periodic maintenance.....	27
5.2	Keep the device clean.....	27
5.3	Manufacturer	27

5.4 Returning the device to the manufacturer.....	28
5.4.1 General information.....	28
5.4.2 Form (for copying) to accompany a returned device.....	29
6 Notes	30

1.1 Scope of the document

These instructions are applicable only to the explosion-protection version of the TDR level transmitter. For all other data, use the Quick Start and Handbook. If you do not have these documents, please contact the nearest office or download them from the manufacturer's internet site.

**INFORMATION!**

The information in these supplementary instructions only contains the data applicable to explosion protection. The technical data for the non-Ex version in the Handbook shall be valid in its current version, provided that it is not rendered invalid or replaced by these supplementary instructions.

**WARNING!**

Installation, commissioning and maintenance may only be carried out by "Personnel trained in explosion protection".

1.2 Device description

This device is a 2-wire level transmitter that uses TDR (Time Domain Reflectometry) / Guided Radar technology. It measures the level, distance, volume and mass of liquids, liquid gases, pastes, powders, slurries and granular products. Measurements are displayed via a DTM (device type manager) for remote communication or an optional integrated display screen with wizard-driven setup and online help functions.

**INFORMATION!****Devices used in China**

There are 4 device versions. The last letters in the model name identify the version:

- *C -L = for the compact version used in liquid applications*
- *C = for compact version used in other applications*
- *F -L = for the remote version used in liquid applications*
- *F = for the remote version used in other applications*

The level transmitter is approved for use in potentially explosive atmospheres when equipped with the appropriate options.

1.3 Standards and approvals

**DANGER!**

In compliance with NEPSI scheme regulations, the Ex ia, Ex iaD, Ex d ia and Ex iaD tD-approved versions of the device described in these Supplementary Instructions agrees with Chinese National Standards GB 3836.1-2010, GB 3836.2-2010, GB 3836.4-2010, GB 3836.19-2010, GB 3836.20-2010 and GB 12476.1-2013. The Ex ia, Ex iaD, Ex d ia and Ex iaD tD-approved versions are certified for use in hazardous areas by The National Supervision and Inspection Centre for Explosion Protection and Safety of Instrumentation (NEPSI) under GYJ18-1110X.

**WARNING!**

Carefully read the NEPSI explosion protection certificate of conformity. Obey the boundary conditions.

1.4 Equipment protection levels (EPL) and dust zones

1.4.1 Ex ia and Ex iaD-approved devices

The Ex ia-approved device is suitable for use in potentially explosive atmospheres of all flammable substances in Gas Groups IIA, IIB and IIC when fitted with appropriate options. It is certified for applications for which an EPL of Ga/Gb or Gb is necessary.

The Ex iaD-approved device is suitable for use in potentially explosive atmospheres of all flammable substances in Dust Zones 20/21 when fitted with appropriate options.

1.4.2 Ex d ia and Ex iaD tD-approved devices

The Ex d ia-approved device is suitable for use in potentially explosive atmospheres of all flammable substances in Gas Groups IIA, IIB and IIC when fitted with the appropriate options. It is certified for applications for which an EPL of Ga/Gb or Gb is necessary.

The Ex iaD tD-approved device is suitable for use in potentially explosive atmospheres of all flammable substances in Dust Zones 20/21 when fitted with the appropriate options.

1.5 NEPSI nameplates

Signal converter housing (compact and remote (field) versions)

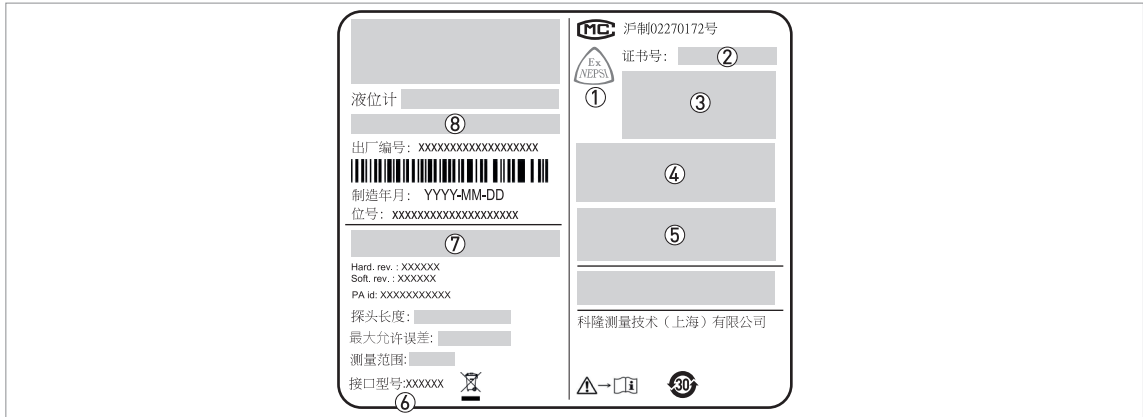

Figure 1-1: Nameplate on the signal converter housing (compact and remote (field) versions) – Chinese text for devices made in China

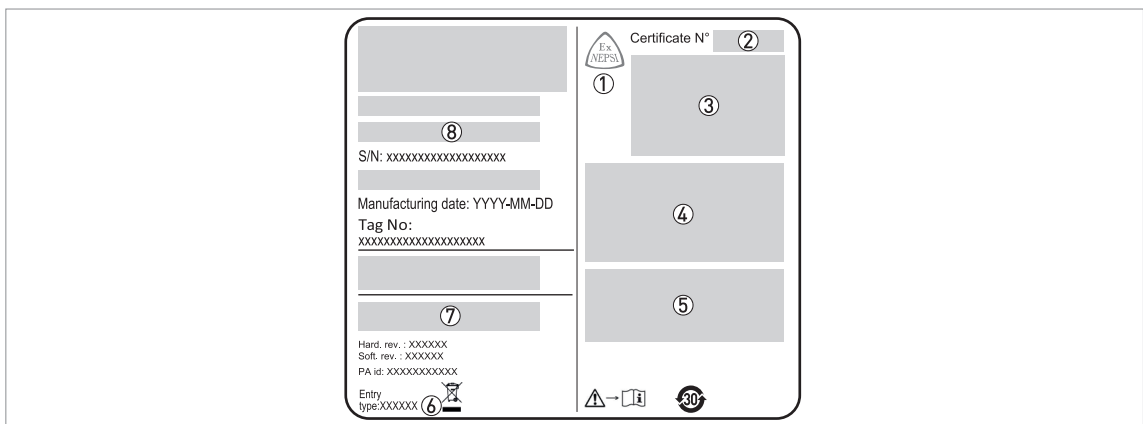

Figure 1-2: Nameplate on the signal converter housing (compact and remote (field) versions) – English text for devices made outside of China

- ① Approval logo
- ② NEPSI certification agency code
- ③ Types of device protection including approved Gas Groups and temperature classes (T6...T3 or T2 – depends on the probe type), equipment protection level, Dust Zones (certification agrees with test method "A"), maximum surface temperature and degree of ingress protection (if fitted with the appropriate cable glands)
- ④ **4...20 mA passive – HART output option (Ex ia approvals):** Intrinsically-safe circuit data
4...20 mA passive – HART output option (Ex d ia approvals): Maximum voltage in accordance with GB 3836.1. Refer to ⑥ for the input voltage range. Minimum waiting time after power-off before it is safe to open the terminal compartment.
Fieldbus (FF or PROFIBUS PA) options: Entity or FISCO power supply parameters
- ⑤ Text: For ambient temperature data, please refer to the installation and operating manual
- ⑥ Cable entry type and size (M20×1.5 or ½ NPT)
- ⑦ Input voltage range and maximum current (4...20 mA passive – HART) / basic current (FF or PROFIBUS PA)
- ⑧ Type code – for more data, refer to "Order code" in the handbook

Probe housing (remote (field) version)

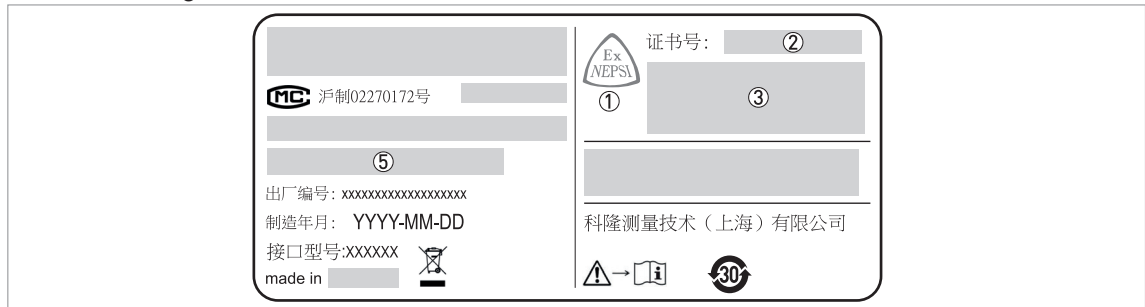

Figure 1-3: Nameplate on the probe housing (remote (field) version) – Chinese text for devices made in China

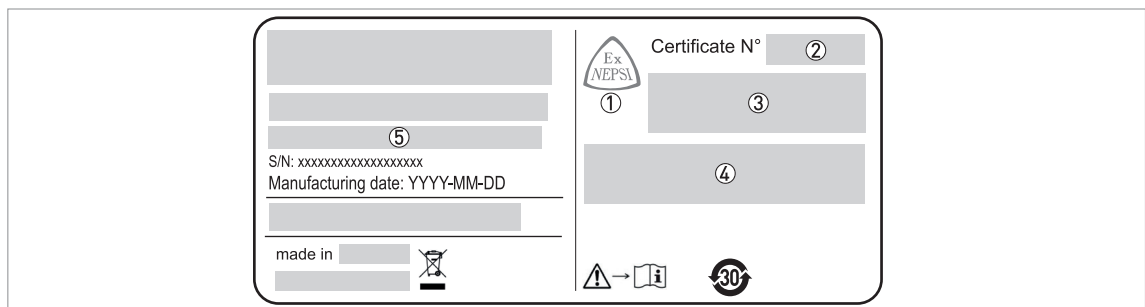

Figure 1-4: Nameplate on the probe housing (remote (field) version) – English text for devices made outside of China

- ① Approval logo
- ② NEPSI certification agency code
- ③ Types of device protection including approved Gas Groups and temperature classes (T6...T3 or T2 – depends on the probe type), equipment protection level, Dust Zones (certification agrees with test method "A"), maximum surface temperature and degree of ingress protection (if fitted with the appropriate cable glands)
- ④ Text: For ambient temperature data, please refer to the installation and operating manual
- ⑤ Type code – for more data, refer to "Order code" in the handbook

2.1 Precautions

2.1.1 General notes



WARNING!

When you install the device, obey the conditions in the certificate of conformity. You can download the certificate from our internet site.



DANGER!

This installation must agree with Chinese Law and NEPSI regulations. For more data, refer to the related NEPSI explosion protection certificates of conformity and these Chinese National Standards:

- **GB 505257:** Code for construction and acceptance of electric device for explosion atmospheres and fire hazard electrical equipment installation engineering,
- **GB 3836.13:** Electrical apparatus for explosive gas atmospheres – Part 13: Repair and overhaul for apparatus used in explosive gas atmospheres,
- **GB 3836.15:** Electrical apparatus for explosive gas atmospheres – Part 15: Electrical installation in hazardous area (other than mines), and
- **GB 3836.16:** Electrical apparatus for explosive gas atmospheres – Part 16: Inspection and maintenance of electrical installation (other than mines)



DANGER!

The device contains a PTFE boundary wall between the process and the signal converter. Do not use the device in the process if the PTFE part is not resistant to corrosion by the tank product.

2.1.2 Electrostatic discharge



DANGER!

Risk of electrostatic discharge from:

- *the painted surfaces of the aluminium housing*
- *the plastic protective sheathes (PVC, PVDF or PP) on single rod probes, and*
- *the coated single cable probes (PFA, PP, PTFE, FEP)*



DANGER!

Take the necessary antistatic precautions if:

- *you handle the device in potentially explosive atmospheres,*
- *you install the device in potentially explosive atmospheres or*
- *you use the device in potentially explosive atmospheres.*

Install the device correctly to prevent electrostatic discharge. Make sure that all equipment is correctly grounded.

Make sure that the housing and adjacent objects do not rub together.

If dirt collects on the device, clean it with a damp cloth.

Do not install in a location where the electrostatic charge can increase. This includes:

- locations near ventilation systems,
- locations where there is a risk of an increase in electrostatic charge caused by compressed air and dust,
- locations near machines that use friction,
- locations near systems that apply electrons as a spray (e.g. near electrostatic painting systems), and
- locations near other machines and systems that can have large electrostatic charges.

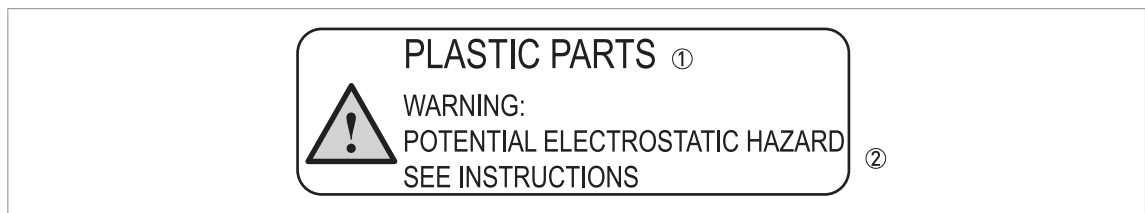

Figure 2-1: ESD warning sticker (below the device nameplate)

① Text: Plastic Parts

② Text: Warning! Potential electrostatic hazard – see instructions

2.2 Operating conditions

The allowable ambient temperature and corresponding flange temperature range for the device depends on the temperature classes marked on the nameplate.

2.2.1 Ambient and flange temperature

The equipment protection level and temperature class give the ambient temperature and related flange temperature ranges for the device.



WARNING!

The gasket temperature must be in the approved limits. For more data, refer to "Pressure and temperature ranges" in the Installation chapter of the handbook.

Definitions

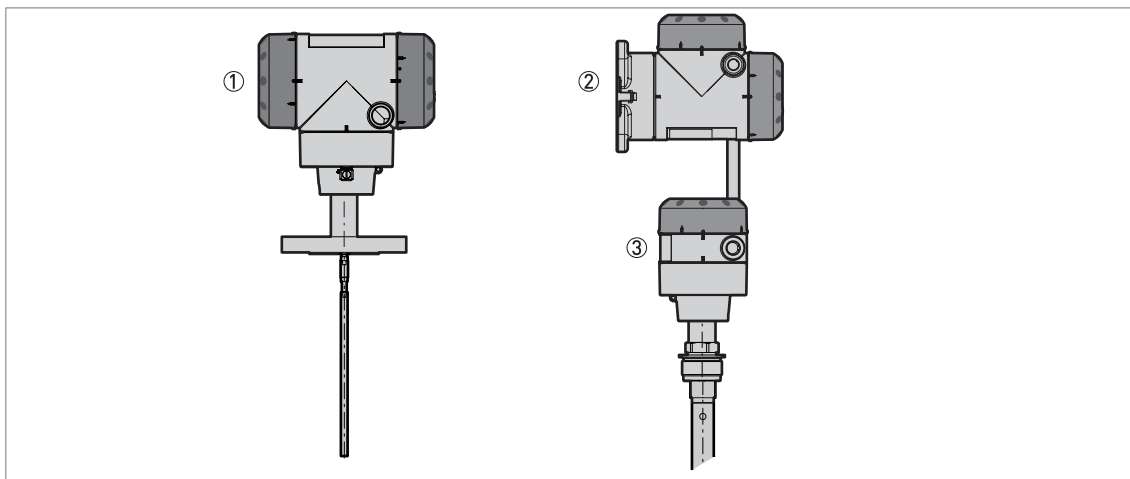

Figure 2-2: Definitions

- ① Compact version: Signal converter, process connection and probe
- ② Remote (Field) version: remote converter
- ③ Remote (Field) version: probe housing, process connection and probe



WARNING!

Compact version only: If the device is used in a potentially explosive atmosphere that contains dust, do not install the device on the side of the tank.

If the device must operate at a high process temperature, make sure that the maximum flange temperature and maximum ambient temperature are not more than the values given in the table.



INFORMATION!

If the device is equipped with the Metaglas® option or the Ø24/32 mm adaptor for the OPTIFLEX 1300 C, use the values that follow.

The temperature data that follows is applicable to devices that have the 4...20 mA passive - HART, PROFIBUS PA or FOUNDATION™ fieldbus output options.

Compact versions

EPL Ga/Gb: Ex ia and Ex d ia devices

Temperature class	Maximum ambient temperature						Max. flange temperature	
	Ø2 mm / Ø0.08" single cable probe (HT version)		Ø2 mm / Ø0.08" single cable probe (other versions)		All other probe types			
	[°C]	[°F]	[°C]	[°F]	[°C]	[°F]	[°C]	[°F]
T6	+54	+129	+52	+125	+53	+127	+60	+140
T5	+70	+158	+70	+158	+70	+158	+60	+140
T4	+80	+176	+80	+176	+80	+176	+60	+140

Temperature class	Minimum ambient temperature						Min. flange temperature	
	Ø2 mm / Ø0.08" single cable probe (HT version)		Ø2 mm / Ø0.08" single cable probe (other versions)		All other probe types			
	[°C]	[°F]	[°C]	[°F]	[°C]	[°F]	[°C]	[°F]
T6...T2	-40	-40	-40	-40	-40	-40	-20	-4

Compact version

EPL Gb: Ex ia and Ex d ia devices

Temperature class	Maximum ambient temperature						Max. flange temperature	
	Ø2 mm / Ø0.08" single cable probe (HT version)		Ø2 mm / Ø0.08" single cable probe (other versions)		All other probe types			
	[°C]	[°F]	[°C]	[°F]	[°C]	[°F]	[°C]	[°F]
T6	+54	+129	+52	+125	+53	+127	+60	+140
	+51	+124	+42	+107	+45	+113	+85	+185
T5	+69	+156	+67	+152	+68	+154	+75	+167
	+66	+151	+57	+134	+60	+140	+100	+212
T4	+79	+174	+77	+170	+78	+176	+85	+185
	+76	+169	+67	+152	+70	+158	+110	+230
	+73	+163	+57	+134	+62	+143	+135	+275
T3	+71	+160	+51	+124	+57	+134	+150	+302
	+68	+154	-	-	-	-	+180 ①	+356 ①
	+65	+149	-	-	-	-	+200 ①	+392 ①
T2	+60	+140	-	-	-	-	+250 ①	+482 ①
	+54	+129	-	-	-	-	+300 ①	+572 ①

① Make sure that gasket temperature is in the specified limits. For more data, refer to the handbook.

Temperature class	Minimum ambient temperature						Min. flange temperature	
	Ø2 mm / Ø0.08" single cable probe (HT version)		Ø2 mm / Ø0.08" single cable probe (other versions)		All other probe types			
	[°C]	[°F]	[°C]	[°F]	[°C]	[°F]	[°C]	[°F]
T6...T2	-40	-40	-40	-40	-40	-40	-40 ①	-40 ①
	-39	-38	-36	-32	-37	-34	-50 ①	-58 ①

① Make sure that gasket temperature is in the specified limits. For more data, refer to the handbook.

Remote (Field) versions (probe housing only)
EPL Ga/Gb: Ex ia and Ex d ia devices

Temperature class	Maximum ambient temperature						Max. flange temperature	
	Ø2 mm / Ø0.08" single cable probe (HT version)		Ø2 mm / Ø0.08" single cable probe (other versions)		All other probe types			
	[°C]	[°F]	[°C]	[°F]	[°C]	[°F]	[°C]	[°F]
T6	+51	+123	+49	+120	+49	+120	+60	+140
T5	+70	+158	+70	+158	+70	+158	+60	+140
T4	+80	+176	+80	+176	+80	+176	+60	+140

Temperature class	Minimum ambient temperature						Min. flange temperature	
	Ø2 mm / Ø0.08" single cable probe (HT version)		Ø2 mm / Ø0.08" single cable probe (other versions)		All other probe types			
	[°C]	[°F]	[°C]	[°F]	[°C]	[°F]	[°C]	[°F]
T6...T2	-40	-40	-40	-40	-40	-40	-20	-4



INFORMATION!

Remote converter

The maximum ambient temperature, T_a , permitted depends on the temperature class:

- $T_a = +60^\circ\text{C}$ for class T6
- $T_a = +70^\circ\text{C}$ for class T5
- $T_a = +80^\circ\text{C}$ for class T4

Remote (Field) version (probe housing only)
EPL Gb: Ex ia and Ex d ia devices

Temperature class	Maximum ambient temperature						Max. flange temperature	
	Ø2 mm / Ø0.08" single cable probe (HT version)		Ø2 mm / Ø0.08" single cable probe (other versions)		All other probe types			
	[°C]	[°F]	[°C]	[°F]	[°C]	[°F]	[°C]	[°F]
T6	+51	+123	+49	+120	+49	+120	+60	+140
	+48	+118	+39	+102	+43	+109	+85	+185
T5	+66	+150	+64	+147	+64	+147	+75	+167
	+65	+149	+54	+129	+58	+136	+100	+212
T4	+79	+174	+77	+170	+78	+176	+85	+185
	+75	+167	+64	+147	+68	+154	+110	+230
	+71	+160	+51	+124	+59	+138	+135	+275
T3	+69	+156	+43	+109	+54	+129	+150	+302
	+65	+149	-	-	-	-	+180 ①	+356 ①
	+62	+143	-	-	-	-	+200 ①	+392 ①
T2	+54	+129	-	-	-	-	+250 ①	+482 ①
	+47	+116	-	-	-	-	+300 ①	+572 ①

① Make sure that gasket temperature is in the specified limits. For more data, refer to the handbook.

Temperature class	Minimum ambient temperature						Min. flange temperature	
	Ø2 mm / Ø0.08" single cable probe (HT version)		Ø2 mm / Ø0.08" single cable probe (other versions)		All other probe types			
	[°C]	[°F]	[°C]	[°F]	[°C]	[°F]	[°C]	[°F]
T6...T2	-40	-40	-40	-40	-40	-40	-40 ①	-40 ①
	-39	-38	-35	-31	-36	-32	-50 ①	-58 ①

① Make sure that gasket temperature is in the specified limits. For more data, refer to the handbook.



INFORMATION!

Remote converter

The maximum ambient temperature, T_a , permitted depends on the temperature class:

- $T_a = +60^\circ\text{C}$ for class T6
- $T_a = +70^\circ\text{C}$ for class T5
- $T_a = +80^\circ\text{C}$ for class T4

Compact and Remote (Field) versions
Dust Zones 20/21: Ex iaD and Ex iaD tD devices

Maximum flange temperature		Maximum ambient temperature											
		Ø2 mm / Ø0.08" single cable probe (HT version)				Ø2 mm / Ø0.08" single cable probe (other versions)				All other probe types			
		Compact version		Remote (Field) version		Compact version		Remote (Field) version		Compact version		Remote (Field) version	
[°C]	[°F]	[°C]	[°F]	[°C]	[°F]	[°C]	[°F]	[°C]	[°F]	[°C]	[°F]	[°C]	[°F]
+80	+176	+80	+176	+80	+176	+80	+176	+80	+176	+80	+176	+80	+176
+90	+194	+79	+174	+79	+174	+76	+169	+75	+167	+77	+170	+76	+169
+100	+212	+78	+172	+77	+170	+72	+161	+70	+158	+74	+165	+73	+163
+110	+230	+76	+169	+76	+169	+68	+154	+64	+147	+70	+158	+69	+156
+120	+248	+75	+167	+74	+165	+64	+147	+59	+138	+67	+152	+65	+149
+130	+266	+74	+165	+73	+163	+59	+138	+54	+129	+64	+147	+61	+142
+140	+284	+73	+163	+71	+160	+55	+131	+49	+120	+61	+142	+58	+136
+150	+302	+72	+161	+70	+158	+51	+124	+43	+109	+57	+134	+54	+129
+160	+320	+71	+160	+68	+154	-	-	-	-	-	-	-	-
+170	+338	+69	+156	+67	+152	-	-	-	-	-	-	-	-
+180	+356	+68	+154	+65	+149	-	-	-	-	-	-	-	-
+190	+374	+67	+152	+64	+147	-	-	-	-	-	-	-	-
+200	+392	+66	+151	+62	+144	-	-	-	-	-	-	-	-
+210	+410	+65	+149	+61	+142	-	-	-	-	-	-	-	-
+220	+428	+64	+147	+59	+138	-	-	-	-	-	-	-	-
+230	+446	+62	+143	+58	+136	-	-	-	-	-	-	-	-
+240	+464	+61	+142	+56	+133	-	-	-	-	-	-	-	-
+250	+482	+60	+140	+55	+131	-	-	-	-	-	-	-	-
+260	+500	+59	+138	+53	+127	-	-	-	-	-	-	-	-
+270	+518	+58	+136	+52	+125	-	-	-	-	-	-	-	-
+280	+536	+57	+134	+50	+122	-	-	-	-	-	-	-	-
+290	+554	+55	+131	+49	+120	-	-	-	-	-	-	-	-
+300	+572	+54	+129	+47	+116	-	-	-	-	-	-	-	-

2.2.2 Maximum surface temperature of the housing for dust applications



WARNING!

Ex iaD and Ex iaD tD devices

If the ambient and flange temperatures of the device are not more than values given in the table for devices that operate in Dust Zones, the surface temperature of the housing (compact or remote version) will not be more than +90°C / +194°F. In these conditions, the maximum surface temperature of other parts (process connection etc.) can be more than the maximum housing surface temperature, but it will not be more than the process temperature.

For more data, refer to the table for devices that operate in Dust Zones 20 and 21 in the "Ambient and flange temperature" section.

2.2.3 Process pressure

Equipment protection level (EPL)	Allowable process pressure	
	[kPa]	[psi]
Ga/Gb	80...110	11.6...16
Others	As per non-Ex device	As per non-Ex device

3.1 General notes



WARNING!

- De-energize the circuit.
- Use the applicable cable glands for the cable entry openings in the housing (M20×1.5 or ½ NPT). For the cable entry size, refer to the device nameplate.
- If ambient temperature >65°C / >149°F, use heat-resistant cables, cable glands and cable entry plugs certified for continuous operation above +80°C / +176°F.

3.2 Terminal compartment

3.2.1 How to open the terminal compartment



WARNING!

If dirt collects on the housing, clean the device with a damp cloth before you remove the terminal compartment cover.

How to open the Ex i terminal compartment

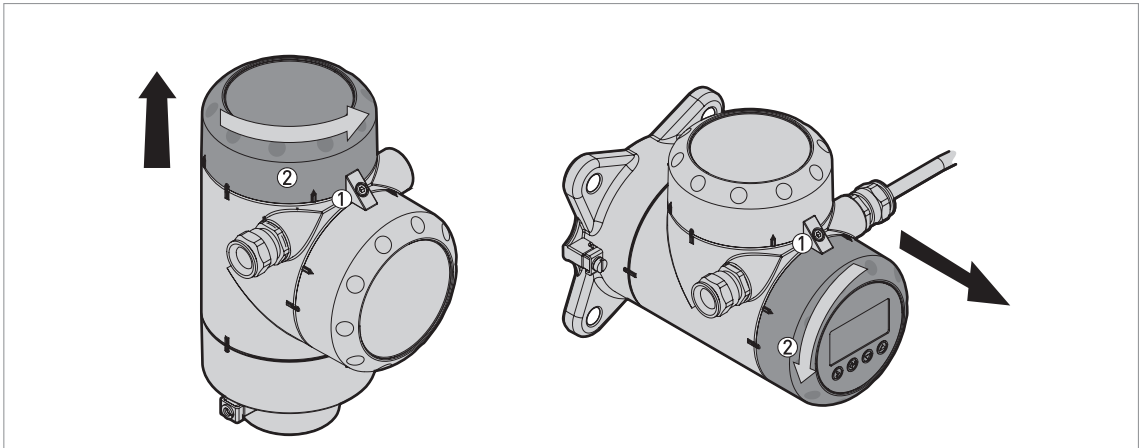

Figure 3-1: How to open the Ex i terminal compartment

How to open the Ex d / Ex t terminal compartment

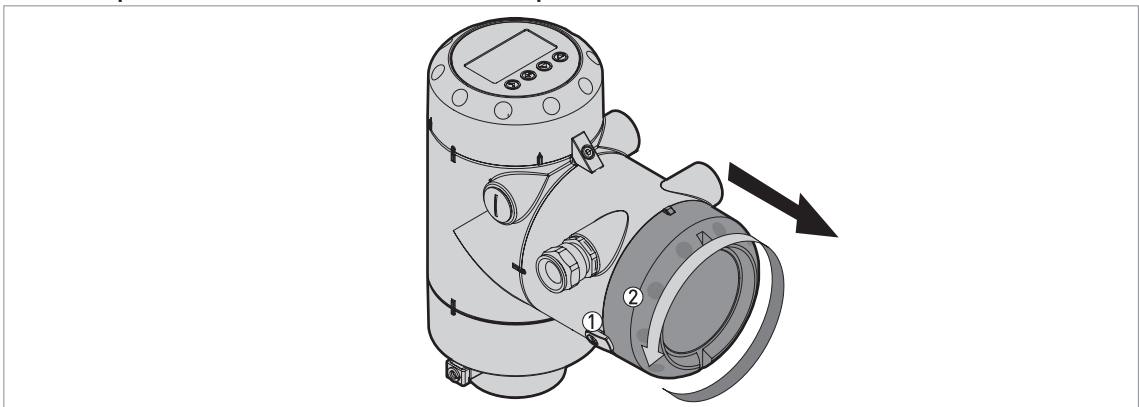

Figure 3-2: How to open the Ex d / Ex t terminal compartment

- ① Cover stop
- ② Terminal compartment cover

Equipment needed (not supplied)

- For Ex i-approved devices: 3 mm Allen wrench.
- For Ex d- / Ex t-approved devices: 2.5 mm Allen wrench.



INFORMATION!

Ex i applications

If you remove the terminal compartment cover, the device has a degree of ingress protection IP20.



WARNING!

Ex d / Ex t applications

Do not remove the terminal compartment cover while the electrical power is connected.



- De-energize the circuit.
- **Ex i-approved devices:** Remove the cover stop ①.
 ➡ Use a 3 mm Allen wrench.
- **Ex d- / Ex t-approved devices:** After the time given in the table that follows, remove the cover stop ①.
 ➡ Use a 2.5 mm Allen wrench.
- Remove the terminal compartment cover ②.

Temperature class	Waiting time before opening
	[minutes]
T6, T5	10
T4, T3, T2	Not necessary

3.2.2 How to close the terminal compartment



Ex i applications

- Attach the terminal compartment cover ②. Turn the terminal compartment cover carefully to prevent damage to the thread and the gasket.
- Make sure that the terminal compartment cover is tight.
- Use a 3 mm Allen wrench to attach the cover stop ①.
- Make sure that the cover stop ① screw is tight.



DANGER!

Ex d / Ex t applications

Make sure that the terminal compartment is correctly sealed. An explosion can cause death or injury to personnel and/or damage to equipment. Obey the instructions that follow:



Ex d / Ex t applications

- Attach the terminal compartment cover ②. Turn the terminal compartment cover carefully to prevent damage to the thread and the gasket.
- Make sure that the terminal compartment cover is tight.
- Use a 2.5 mm Allen wrench to attach the cover stop ①.
- Make sure that the cover stop ① screw is tight.

3.3 Terminal tightening capacity

The terminal tightening capacity for the current output terminal and the signal cable is:

Output option	Type of wire	Terminal tightening capacity	
		[mm ²]	[AWG]
4...20 mA + HART	Rigid	2.5	13
	Flexible	2.5	13
PROFIBUS PA or FOUNDATION™ fieldbus	Rigid	3.3	12
	Flexible	3.3	12

3.4 Equipotential bonding system

Compact version

There is a terminal at the bottom of the converter that can be used as an equipotential bonding conductor. Connect the device to the equipotential bonding system for the hazardous location.

Remote (Field) version

There is a terminal on the wall support and a terminal at the bottom of the probe housing that can be used as equipotential bonding conductors. Connect the device to the equipotential bonding system for the hazardous location.

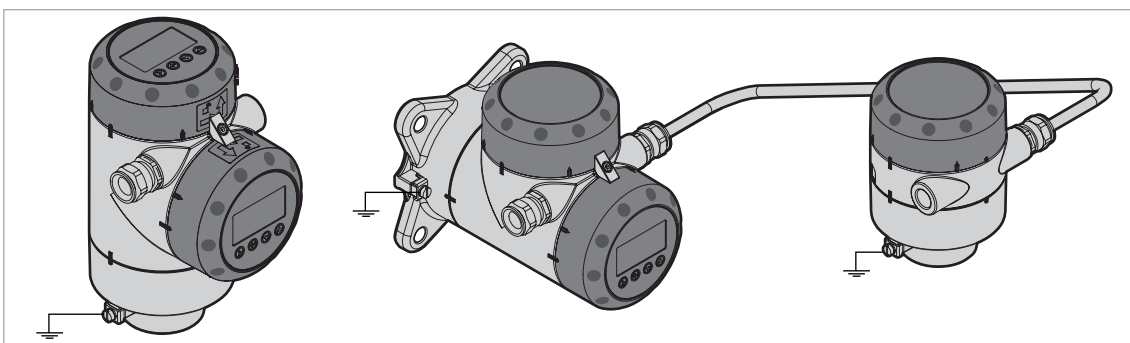

Figure 3-3: Ex i applications: Terminals for the equipotential bonding system

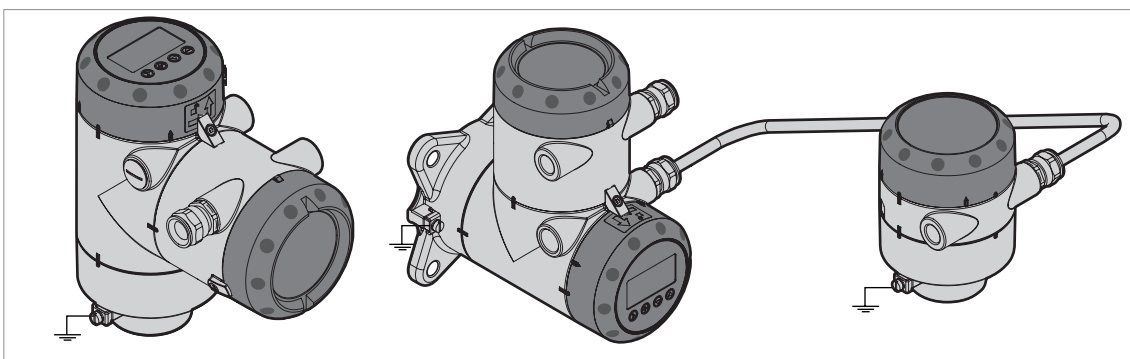

Figure 3-4: Ex d / Ex t applications: Terminals for the equipotential bonding system

3.5 Ex ia and Ex iaD equipment

3.5.1 How to connect the electrical cables

Refer to the handbook for data about the device terminals.

Cable glands are supplied on customer demand. If you supply the cable glands, this part must have a degree of ingress protection $IP \geq 6X$ (IEC 60529). We recommend that you use a part that has a degree of ingress protection $IP \geq 66$. Make sure that the cable gland is sealed.



Obey the instructions that follow:

- Use the electrical connection procedure in the Handbook.
- Put the electrical wires in position and safely attach them to prevent damage. The electrical wires must also be a sufficient distance from hot surfaces.
- Make sure that unused electrical wires are safely connected to the ground potential of the hazardous area. If this is not possible, make sure that each of the unused electrical wires are safely isolated (other electrical wires, ground etc.) and rated for a test voltage $\geq 500 V_{RMS}$.
- If it is necessary, make sure the electrical wire insulation gives good protection from corrosion.
- Connect only to separate certified, intrinsically-safe circuits. Make sure that the electrical circuit characteristics are not more than the values that follow.
- Do not remove more than 6 mm / 0.2" of insulation from the wire.

3.5.2 Maximum intrinsically-safe values for the electrical circuit

Output option		Intrinsically-safe values for the electrical circuit				
		U_i	I_i	P_i	C_i	L_i
		[V]	[mA]	[W]	[nF]	[μ H]
4...20 mA passive - HART		≤ 30	≤ 300	≤ 1	$= 16$	$= 27$
PROFIBUS PA FOUNDATION™ fieldbus	Entity	≤ 24	≤ 300	≤ 1.2	$= 1$	$= 2$
	FISCO	≤ 17.5	≤ 380	≤ 5.32	$= 1$	$= 2$

3.5.3 Supply voltage

Level transmitter with the 4...20 mA output option

	Minimum voltage at output terminals [V DC]	Maximum voltage at output terminals [V DC]
Current output terminals	11.5 ①	30 ①

① For a current output of 22 mA

Level transmitter with the PROFIBUS PA or FOUNDATION fieldbus output option

		Minimum voltage at output terminals [V DC]	Maximum voltage at output terminals [V DC]
Output terminals	Entity	9	24
	FISCO	9	17.5

3.5.4 Electrical schematic

Level transmitter with the 4...20 mA passive – HART output option

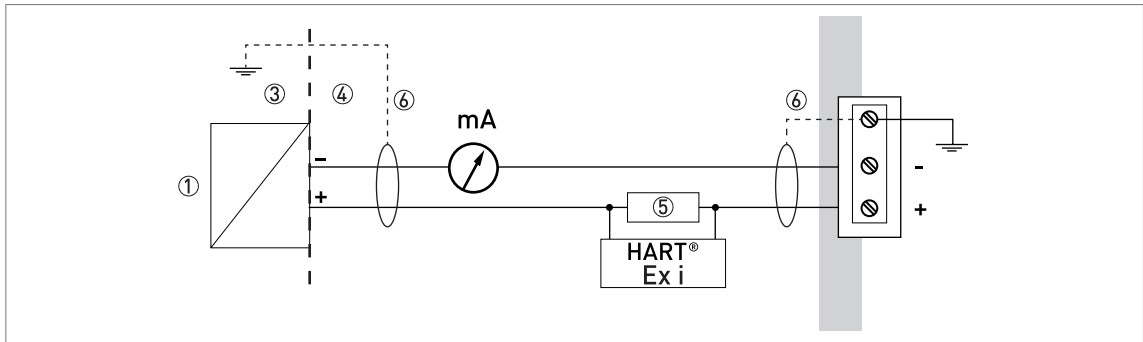

Figure 3-5: Electrical schematic for Ex ia and Ex iaD-approved equipment with the 4...20 mA passive – HART output option

Level transmitter with the FOUNDATION™ fieldbus or PROFIBUS PA output option

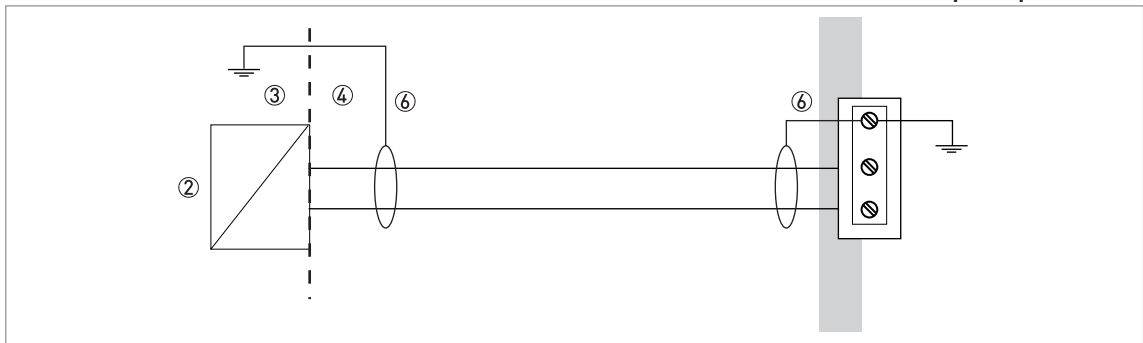

Figure 3-6: Electrical schematic for Ex ia and Ex iaD-approved equipment with the FOUNDATION™ fieldbus or PROFIBUS PA output option

- ① Intrinsically-safe power supply
- ② Approved barrier with entity parameters or FISCO power supply
- ③ Non-Ex zone
- ④ Ex zone
- ⑤ Resistor for HART® communication
- ⑥ Grounding wire – if the electrical cable is shielded (braided wire etc.). NOTE: Shielded electrical cable is mandatory for fieldbus output options.

Remote (Field) version

The signal cable (between the converter electronics and the probe electronics) is supplied by the manufacturer for NEPSI applications. The signal cable cannot be changed by the user. For more data, speak to the supplier.

3.6 Ex d ia and Ex iaD tD equipment

3.6.1 General notes

Ex d ia and Ex iaD tD-approved equipment have two separate compartments. The electronics in the electronics block compartment are Ex ia-approved and the terminals compartment is Ex d / Ex t-approved.

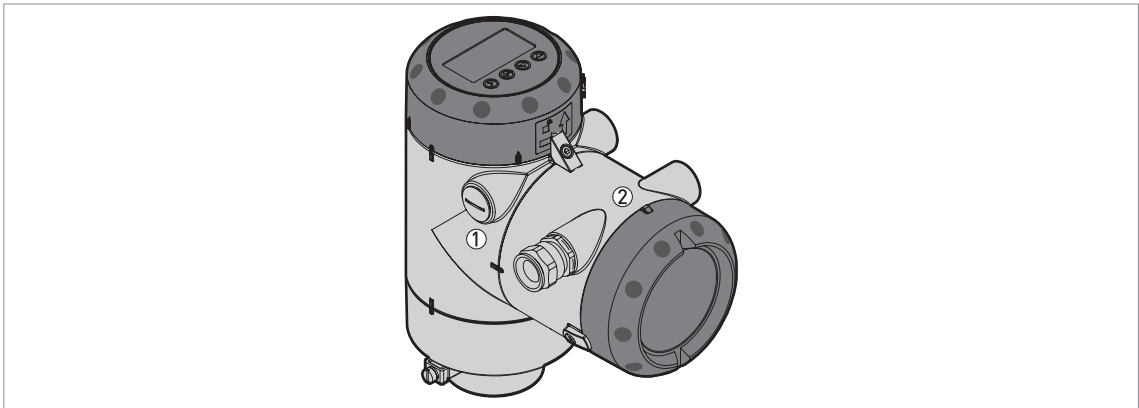

Figure 3-7:

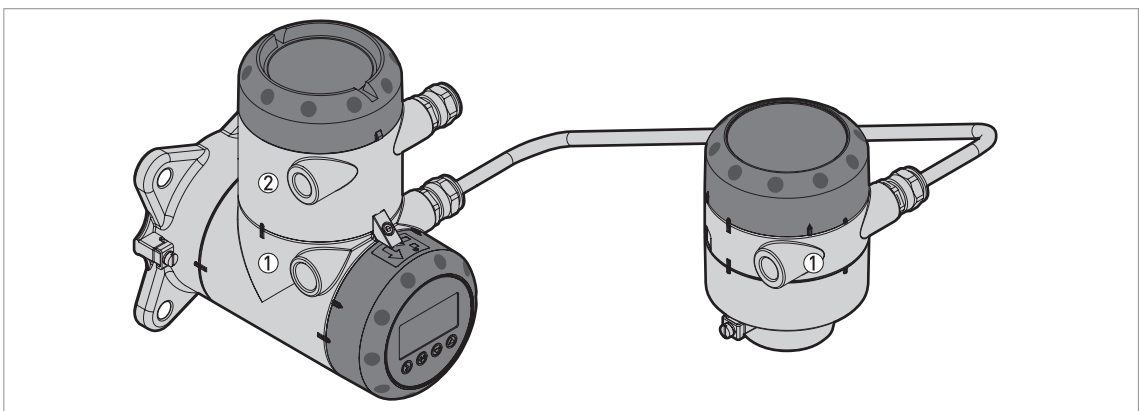

Figure 3-8: Remote (Field) version: Compartments in Ex d ia and Ex iaD tD-approved equipment

- ① Electronics block (Ex ia) compartment
- ② Terminal (Ex d / Ex t) compartment



INFORMATION!

For more data about the flamepath dimensions, speak or write to your supplier.

3.6.2 How to connect the electrical cables

Cable glands are supplied on customer demand. If you supply the cable glands, this part must have a degree of ingress protection $IP \geq 6X$ (IEC 60529).



WARNING!

*Use only Ex d-approved cable glands and plugs for Ex d applications. Use only Ex t-approved cable glands and plugs for Ex t applications.
Do not remove more than 6 mm / 0.2" of insulation from the wire.*



- Do not remove more than 6 mm / 0.2" of insulation from the wire.
- Connect the load resistor to the positive terminal of the power supply
- Ground the negative connection.
- If the load resistor has to be connected to the negative terminal, the loop resistance must not be more than 350 ohms.



CAUTION!

4...20 mA passive - HART output option: Do not ground the positive connection.

3.6.3 Supply voltage

Level transmitter with the 4...20 mA output option

	Minimum voltage at output terminals [V DC]	Maximum voltage at output terminals [V DC]
Current output terminals	13.5 ①	36 ①

① For a current output of 22 mA

Level transmitter with the PROFIBUS PA or FOUNDATION fieldbus output option

		Minimum voltage at output terminals [V DC]	Maximum voltage at output terminals [V DC]
Output terminals	Entity	9	24
	FISCO	9	17.5

For more data, refer to *Maximum intrinsically-safe values for the electrical circuit* on page 21.

3.6.4 Electrical schematic



DANGER!

Keep the grounding wire a minimum distance of 2 mm / 0.83" away from the output terminal.



CAUTION!

Make sure that you connect the load resistor to the positive side.

Level transmitter with the 4...20 mA passive – HART output option

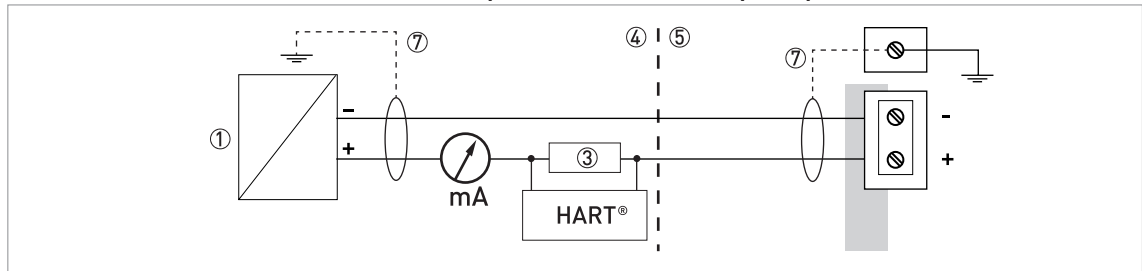

Figure 3-9: Electrical schematic for Ex d ia and Ex iaD tD-approved equipment (with galvanic isolation)

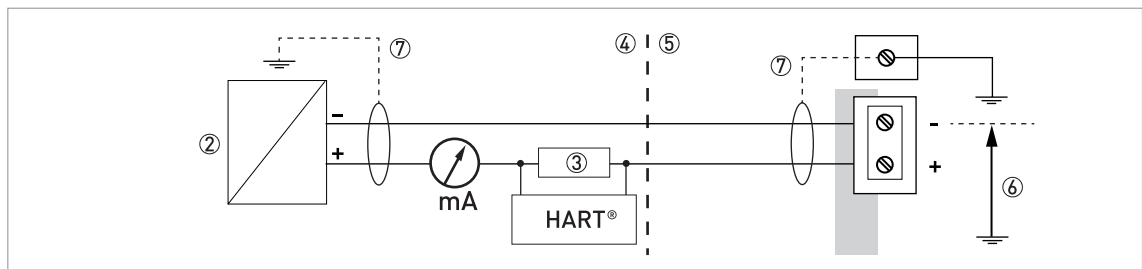

Figure 3-10: Electrical schematic for Ex d ia and Ex iaD tD-approved equipment (without galvanic isolation)

- ① Galvanically-isolated power supply
- ② Power supply
- ③ Resistor for HART® communication
- ④ Non-Ex zone
- ⑤ Ex zone
- ⑥ $|U| < 13\text{ V}$
- ⑦ Grounding wire – if the electrical cable is shielded (braided wire etc.)

Level transmitter with the FOUNDATION™ fieldbus or PROFIBUS PA output option

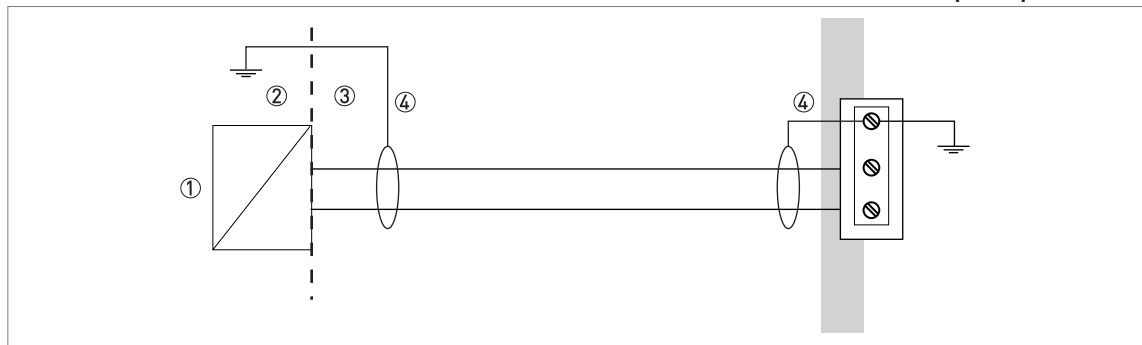

Figure 3-11: Electrical schematic for Ex d ia and Ex iaD tD-approved equipment with the FOUNDATION™ fieldbus or PROFIBUS PA output option

- ① Approved barrier with entity parameters or FISCO power supply. For more data, refer to *Maximum intrinsically-safe values for the electrical circuit* on page 21.
- ② Non-Ex zone
- ③ Ex zone
- ④ Grounding wire. NOTE: Shielded electrical cable is mandatory for fieldbus output options.

Remote (Field) version

The signal cable (between the converter electronics and the probe electronics) is supplied by the manufacturer for NEPSI applications. The signal cable cannot be changed by the user. For more data, speak to the supplier.

**WARNING!**

Make sure that it is safe to supply electrical power. Do a start-up check:



- Are the wetted components (gasket, flange and probe) resistant to corrosion by the tank product?
- Does the information given on the nameplate agree with the application?
- Did you connect the equipotential bonding system correctly?
- **Ex d applications:** Are the cable glands, plugs and adaptors Ex d-approved?
- **Ex t applications:** Are the cable glands, plugs and adaptors Ex t-approved?
- **Ex ia applications:** Are you using an intrinsically-safe barrier within the correct parameters? For more data, refer to *Ex ia and Ex iaD equipment* on page 21. The electrical circuit characteristics must not be more than the maximum intrinsically-safe values.
- Did you install the correct cable glands? Is the terminal compartment correctly sealed?

5.1 Periodic maintenance

No maintenance is necessary.



INFORMATION!

For more data about regular inspections and maintenance procedures for devices with Ex and other approvals, refer to the related supplementary instructions.

5.2 Keep the device clean



DANGER!

If dirt collects on the device, clean it with a damp cloth.

The device contains a PTFE boundary wall between the process and the signal converter. If the PTFE part is not resistant to corrosion by your cleaning agents, do not clean the device with them.

If you use the incorrect cleaning agent (i.e. the device is not resistant to corrosion by your cleaning agent), do not use the device in a hazardous location. If aid is necessary, speak or write to the supplier.

5.3 Manufacturer

If the serial number on the device nameplate starts with the letter "F", this device is made by:

KROHNE S.A.S.
2 Allée des Ors – B.P. 98
26103 Romans-sur-Isère CEDEX
France

If the serial number on the device nameplate starts with the letter "S", this device is made by:

KROHNE Measurement Technology (Shanghai) Co., Ltd.
Minshen Road 555 Songjiang Industrial Zone
Shanghai 201612
China

If you need to return your device for inspection or repair, make sure that you send it to the correct manufacturer and obey the instructions that follow.

5.4 Returning the device to the manufacturer

5.4.1 General information

This device has been carefully manufactured and tested. If installed and operated in accordance with these operating instructions, it will rarely present any problems.



WARNING!

Should you nevertheless need to return a device for inspection or repair, please pay strict attention to the following points:

- *Due to statutory regulations on environmental protection and safeguarding the health and safety of the personnel, the manufacturer may only handle, test and repair returned devices that have been in contact with products without risk to personnel and environment.*
- *This means that the manufacturer can only service this device if it is accompanied by the following certificate (see next section) confirming that the device is safe to handle.*



WARNING!

If the device has been operated with toxic, caustic, radioactive, flammable or water-endangering products, you are kindly requested:

- *to check and ensure, if necessary by rinsing or neutralising, that all cavities are free from such dangerous substances,*
- *to enclose a certificate with the device confirming that it is safe to handle and stating the product used.*

5.4.2 Form (for copying) to accompany a returned device



CAUTION!

To avoid any risk for our service personnel, this form has to be accessible from outside of the packaging with the returned device.

Company:		Address:	
Department:		Name:	
Tel. no.:		Fax no. and/or Email address:	
Manufacturer's order no. or serial no.:			
The device has been operated with the following medium:			
This medium is:	<input type="checkbox"/>	radioactive	
	<input type="checkbox"/>	water-hazardous	
	<input type="checkbox"/>	toxic	
	<input type="checkbox"/>	caustic	
	<input type="checkbox"/>	flammable	
	<input type="checkbox"/>	We checked that all cavities in the device are free from such substances.	
	<input type="checkbox"/>	We have flushed out and neutralized all cavities in the device.	
We hereby confirm that there is no risk to persons or the environment through any residual media contained in the device when it is returned.			
Date:		Signature:	
Stamp:			







KROHNE – Process instrumentation and measurement solutions

- Flow
- Level
- Temperature
- Pressure
- Process Analysis
- Services

Head Office KROHNE Messtechnik GmbH
Ludwig-Krohne-Str. 5
47058 Duisburg (Germany)
Tel.: +49 203 301 0
Fax: +49 203 301 10389
info@krohne.com

The current list of all KROHNE contacts and addresses can be found at:
www.krohne.com

KROHNE