



OPTISONIC 3400 Supplementary instructions

Ultrasonic flow meter

Addendum for hazardous area. These additional instructions are an extension to the OPTISONIC 3400 manual and quick start.



1 Introduction	4
<hr/>	
1.1 Safety instructions from the manufacturer	4
1.1.1 Copyright and data protection	4
1.1.2 Disclaimer	4
1.1.3 Product liability and warranty	5
1.1.4 Information concerning the documentation	5
1.1.5 Warnings and symbols used	6
1.1.6 Manufacturer	7
1.2 Safety instructions for the operator	7
1.3 Approval	7
1.4 OPTISONIC 3400 C(/i)-Ex	8
1.5 OPTISONIC 3000 F/...-Ex	8
1.6 UFC 400 F(/i)-Ex	9
1.7 Marking labels (examples)	10
1.7.1 I/O sticker	12
1.7.2 Nameplate for the measuring sensor (field version)	12
2 Temperature limits	14
<hr/>	
2.1 General	14
2.2 UFC 400 F(/i)-Ex	14
2.3 OPTISONIC 3400 C(/i)-Ex	14
2.4 OPTISONIC 3000 F/...-Ex	15
3 Connection of separate systems	16
<hr/>	
3.1 General	16
3.2 Cable marking	16
3.3 Cable parameters	16
3.4 Equipotential bonding	17
3.4.1 Signal converter	17
3.5 Signal cable connections (filed versions)	17
4 Electrical connections	19
<hr/>	
4.1 General	19
4.2 Cable glands	21
4.3 Field Wiring	21
4.4 Non-"Ex i" I/O connections	22
4.5 "Ex i" I/O connections	24
5 Maintenance and service	26
<hr/>	
5.1 Maintenance	26
5.2 Before and after opening	26
5.3 Replacement of mains fuse	27
5.4 Exchange of electronics unit	28
5.4.1 Field version	29

5.5 Service / repair information	31
5.6 Form (for copying) to accompany a returned device	32
5.7 Disposal	32
6 Notes	33

1.1 Safety instructions from the manufacturer

1.1.1 Copyright and data protection

The contents of this document have been created with great care. Nevertheless, we provide no guarantee that the contents are correct, complete or up-to-date.

The contents and works in this document are subject to copyright. Contributions from third parties are identified as such. Reproduction, processing, dissemination and any type of use beyond what is permitted under copyright requires written authorisation from the respective author and/or the manufacturer.

The manufacturer tries always to observe the copyrights of others, and to draw on works created in-house or works in the public domain.

The collection of personal data (such as names, street addresses or e-mail addresses) in the manufacturer's documents is always on a voluntary basis whenever possible. Whenever feasible, it is always possible to make use of the offerings and services without providing any personal data.

We draw your attention to the fact that data transmission over the Internet (e.g. when communicating by e-mail) may involve gaps in security. It is not possible to protect such data completely against access by third parties.

We hereby expressly prohibit the use of the contact data published as part of our duty to publish an imprint for the purpose of sending us any advertising or informational materials that we have not expressly requested.

1.1.2 Disclaimer

The manufacturer will not be liable for any damage of any kind by using its product, including, but not limited to direct, indirect or incidental and consequential damages.

This disclaimer does not apply in case the manufacturer has acted on purpose or with gross negligence. In the event any applicable law does not allow such limitations on implied warranties or the exclusion of limitation of certain damages, you may, if such law applies to you, not be subject to some or all of the above disclaimer, exclusions or limitations.

Any product purchased from the manufacturer is warranted in accordance with the relevant product documentation and our Terms and Conditions of Sale.

The manufacturer reserves the right to alter the content of its documents, including this disclaimer in any way, at any time, for any reason, without prior notification, and will not be liable in any way for possible consequences of such changes.

1.1.3 Product liability and warranty

The operator shall bear responsibility for the suitability of the device for the specific purpose. The manufacturer accepts no liability for the consequences of misuse by the operator. Improper installation and operation of the devices (systems) will cause the warranty to be void. The respective "Standard Terms and Conditions" which form the basis for the sales contract shall also apply.

1.1.4 Information concerning the documentation

To prevent any injury to the user or damage to the device it is essential that you read the information in this document and observe applicable national standards, safety requirements and accident prevention regulations.

If this document is not in your native language and if you have any problems understanding the text, we advise you to contact your local office for assistance. The manufacturer can not accept responsibility for any damage or injury caused by misunderstanding of the information in this document.

This document is provided to help you establish operating conditions, which will permit safe and efficient use of this device. Special considerations and precautions are also described in the document, which appear in the form of underneath icons.

1.1.5 Warnings and symbols used

Safety warnings are indicated by the following symbols.

**DANGER!**

This information refers to the immediate danger when working with electricity.

**DANGER!**

This warning refers to the immediate danger of burns caused by heat or hot surfaces.

**DANGER!**

This warning refers to the immediate danger when using this device in a hazardous atmosphere.

**DANGER!**

These warnings must be observed without fail. Even partial disregard of this warning can lead to serious health problems and even death. There is also the risk of seriously damaging the device or parts of the operator's plant.

**WARNING!**

Disregarding this safety warning, even if only in part, poses the risk of serious health problems. There is also the risk of damaging the device or parts of the operator's plant.

**CAUTION!**

Disregarding these instructions can result in damage to the device or to parts of the operator's plant.

**INFORMATION!**

These instructions contain important information for the handling of the device.

**LEGAL NOTICE!**

This note contains information on statutory directives and standards.

• **HANDLING**

This symbol designates all instructions for actions to be carried out by the operator in the specified sequence.

➔ **RESULT**

This symbol refers to all important consequences of the previous actions.

1.1.6 Manufacturer

The instrument is developed and manufactured by:
KROHNE Altometer
Kerkeplaat 12
3313 LC Dordrecht
The Netherlands

For information, maintenance or service please contact your nearest local KROHNE representative.

1.2 Safety instructions for the operator



WARNING!

- *Do not change the device. Unauthorized changes affect the explosion safety of the devices.*
- *The prescriptions and regulations as well as the electrical data described in the EC type examination certificate must be obeyed.*
- *Beside the instructions for electrical installations in non-hazardous locations according to the applicable national standard (equivalent to HD 384 or IEC 364, e.g. VDE 0100), especially the regulations in EN 60079-14 "Electrical installations in hazardous locations" or equivalent national standard (e.g. DIN VDE 0165 Part 1) must be strictly followed.*
- *Installation, establishment, utilization and maintenance are only allowed to be executed by personnel with an education in explosion safety!*

These additional instructions are an extension to the installation and operating instructions and only apply to the Ex- versions of the OPTISONIC 3400 C, OPTISONIC 3000 F/... and UFC 400 F/(i) ultrasonic flowmeters. All technical information as described in the Installation and Operating Instructions is applicable, when not specifically excluded, completed or replaced by the instructions in these additional instructions.

1.3 Approval

The OPTISONIC 3400 ultrasonic flowmeters are manufactured according to the European Directive 94/9 EC (ATEX 100a) and IECEx 02 Certification System. The flowmeters are approved for installation and use in hazardous classified locations of Zone 1 and 2 and are in accordance with the European Standards of the IEC/EN 60079 series. The flowmeters are approved for installation and use in hazardous classified locations of Class I, II and III, Division 1 or Division 2.

They have approval number:

DEKRA 13ATEX0092 X - IECEx DEK 13.0023X



INFORMATION!

If you need the EC type approval certificate, please download it from our website.

1.4 OPTISONIC 3400 C(/i)-Ex

The OPTISONIC 3400 C(/i)-Ex is the compact configuration of the UFC 400 ultrasonic signal converter and the OPTISONIC 3000 ultrasonic flow sensor. It provides the ultrasonic transducers in the flow sensor with intrinsically safe (Ex ia) signals; which are only internal circuits. The flow converter is provided with increased safety (Ex e) or intrinsically safe (Ex ia) in-/outputs, indicated by an "i" in the type name and listed as OPTISONIC 3400 C/i- Ex.

The in-/outputs and mains supply connections are located in the terminal compartment, which can either be ordered as "Ex e" (default) or "Ex d" (optional). The explosion safety marking is as follows:

OPTISONIC 3400 C-Ex;

"Ex d" terminal compartment	"Ex e" terminal compartment
II 2 G Ex d [ia] IIC T6...T3 Gb	II 2 G Ex d e [ia] IIC T6...T3 Gb

OPTISONIC 3400 C/i-Ex;

"Ex d" terminal compartment	"Ex e" terminal compartment
II 2(1) G Ex d [ia] [ia Ga] IIC T6...T3 Gb	II 2(1) G Ex d e [ia] [ia Ga] IIC T6...T3 Gb

1.5 OPTISONIC 3000 F/...-Ex

The OPTISONIC 3000 F/...-Ex is the remote (field) configuration of the ultrasonic flow sensor and has intrinsically safe transducer circuits. It is available in 4 versions as follows,

- Cryogenic: low temperature (LT) versions, suitable for process temperatures of -200...+180°C / -328...+356°F
- Standard versions: for process temperature of -45...+180°C / -58...+356°F
- Extra extended versions: (XXT) for process temperatures of -45...+250°C / -58...+482°F.
- High Viscosity versions (HV): for process temperatures of -45...+180°C / -58...+356°F

The normal and XXT-versions are also available as flow sensors, equipped with a closed steel circuit for hot medium (e.g. steam or hot oil), which is called heating jacket (HJ). The maximum temperature of the heating medium never exceeds the maximum permissible process temperature of 180°C (356°F) for the standard versions and 250°C (482°F) for the XXT version.

The flow sensor equipped with a heating jacket, ensures stable process temperatures.

Marking for the different flow sensor types, are listed below.

OPTISONIC 3000 F-Ex & 3000 F/HJ-Ex OPTISONIC 3000 F/LT-Ex	OPTISONIC 3000 F/XT-Ex OPTISONIC 3000 F/XT/HJ-Ex
II 2 G Ex ia IIC T6...T3 Gb	II 2 G Ex ia IIC T6...T2 Gb

The intrinsically safe (Ex ia) transducer circuits of the OPTISONIC 3000 F/...-Ex are connected to an associated device and have the following maximum values:

$U_i = 13,1 \text{ V}$	$I_i = 600 \text{ mA}$	$C_i = 11,6 \text{ nF}$	$L_i = 134 \text{ } \mu\text{H}$
------------------------	------------------------	-------------------------	----------------------------------



INFORMATION!

When thermally insulating the ultrasonic flow sensor, make sure that the temperature of the connection box does not exceed 90°C (194°F).

1.6 UFC 400 F(/i)-Ex

The UFC 400 F(/i)-Ex is the remote (field) configuration of the ultrasonic signal converter and has intrinsically safe (Ex ia) connections to the ultrasonic flow sensor in remote design. The ultrasonic signal converter is either provided with increased safety (Ex e) or intrinsically safe (Ex ia) signal in-/outputs indicated by an "i" in the type name as UFC 400 F/i-Ex. The in-/outputs and mains supply connections are located in the terminal compartment, which can either be configured as "Ex e" (default) or "Ex d" (optional).

The explosion safety marking is as follows:

UFC 400 F-Ex;

"Ex d" terminal compartment	"Ex e" terminal compartment
II 2 G Ex d [ia] IIC T6 Gb	II 2 G Ex d e [ia] IIC T6 Gb

UFC 400 F/i-Ex;

"Ex d" terminal compartment	"Ex e" terminal compartment
II 2(1) G Ex d [ia] [ia Ga] IIC T6 Gb	II 2(1) G Ex d e [ia] [ia Ga] IIC T6 Gb

The intrinsically safe transducer output connections have the following values:

$U_o = 8,2 \text{ V}$	$I_o = 210 \text{ mA}$	$P_o = 435 \text{ mW}$	$C_o = 1,3 \mu\text{F}$ or $0,8 \mu\text{F}$	$L_o = 0,5 \text{ mH}$ or $1,2 \text{ mH}$
-----------------------	------------------------	------------------------	--	--

1.7 Marking labels (examples)

See the marking labels (i.e. data stickers) below of respectively OPTISONIC 3400 C(/i)-Ex ultrasonic compact flowmeter, UFC 400 F(/i)-Ex ultrasonic signal converter in field design, OPTISONIC 3000 F-Ex ultrasonic flow sensor in field design and extended temperature flow sensor type OPTISONIC 3000 F/XXT-Ex.

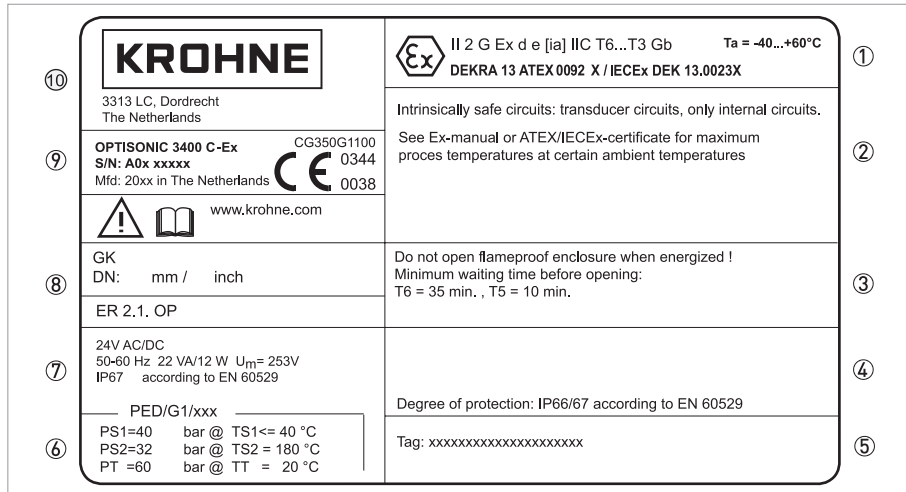

Figure 1-1: OPTISONIC 3400 C-Ex data sticker

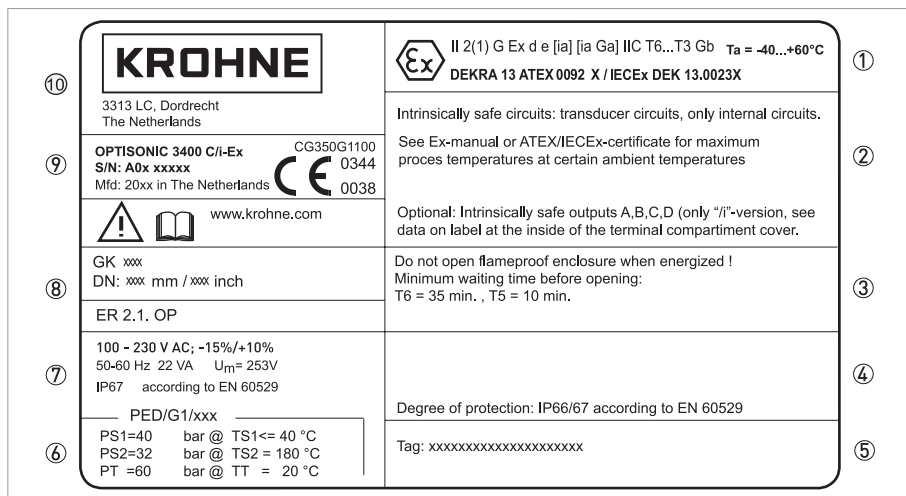

Figure 1-2: OPTISONIC 3400 C/i-Ex data sticker

1. Ex
2. Marking ATEX / IECEx & Certificate numbers / Ambient temperature
3. Ex specific remarks
4. Ex specific warnings
5. Protection class
6. Tag no.
7. PED data, type I / II / II or SEP
8. Mains supply data
9. Calibration data / Size info and Electronic Revision no.
10. Type designation of the flowmeter and CE sign with number(s) of notified body / bodies
11. Name and address of the manufacturer

⑪	KROHNE 3313 LC, Dordrecht The Netherlands	II 2(1) G Ex d e [ia] IIC T6 DEKRA 13 ATEX 0092 X / IECEx DEK 13.0023X Ta = -40...+60°C	①
⑩	UFC 400 F-Ex S/N: A0x xxxxx Mfd: 20xx in The Netherlands CG350xxxxx CE 0344	Intrinsically safe circuits: (xD, xU; x = 1,2 or 3): U _o = 8.2V C _o = 1.3 μF or C _o = 0.8 μF I _o = 210 mA L _o = 0.5 mH L _o = 1.2 mH P _o = 435 mW	②
⑨	GK xxx DN: xxx mm / xxx inch	Do not open flameproof enclosure when energized ! Minimum waiting time before opening: T6 = 35 min. , T5 = 10 min.	③
⑧	ER 2.1. OP		④
⑦	100 - 230 V AC, -15%/+10% 50-60Hz, 22 VA, Um=253V	Degree of protection: IP66/67 according to EN 60529	⑤
⑥	PED/G1/xxx : PS1=40 bar @ TS1<= 40 °C PS2=32 bar @ TS2 = 180 °C PT =60 bar @ TT = 20 °C	Tag: xxxxxxxxxxxxxxxxxxxxxxxx	

Figure 1-3: UFC 400 F-Ex data sticker

⑪	KROHNE 3313 LC, Dordrecht The Netherlands	II 2(1) G Ex d e [ia] [ia Ga] IIC T6 DEKRA 13 ATEX 0092 X / IECEx DEK 13.0023X Ta = -40...+60°C	①
⑩	UFC 400 F/i-Ex S/N: A0x xxxxx Mfd: 20xx in The Netherlands CG350xxxxx CE 0344	Intrinsically safe circuits: (xD, xU; x = 1,2 or 3): U _o = 8.2V C _o = 1.3 μF or C _o = 0.8 μF I _o = 210 mA L _o = 0.5 mH L _o = 1.2 mH P _o = 435 mW	②
⑨	GK xxx DN: xxx mm / xxx inch	Optional: Intrinsically safe outputs A,B,C,D (only "/i"-version, see data on label at the inside of the terminal compartment cover).	③
⑧	ER 2.1. OP	Do not open flameproof enclosure when energized ! Minimum waiting time before opening: T6 = 35 min. , T5 = 10 min.	④
⑦	100 - 230 V AC, -15%/+10% 50-60Hz, 22 VA, Um=253V	Degree of protection: IP66/67 according to EN 60529	⑤
⑥	PED/G1/xxx : PS1=40 bar @ TS1<= 40 °C PS2=32 bar @ TS2 = 180 °C PT =60 bar @ TT = 20 °C	Tag: xxxxxxxxxxxxxxxxxxxxxxxx	

Figure 1-4: UFC 400 F/i-Ex data sticker

1. Marking ATEX / IECEx & Certificate numbers / Ambient temperature
2. Circuit info
3. Ex specific remarks
4. Protection class
5. Tag no.
6. PED data, type I / II / III or SEP
7. Mains supply data
8. Electronic Revision number
9. Calibration data / Size info
10. Type designation of the flowmeter and CE sign with number(s) of notified body / bodies
11. Name and address of the manufacturer

1.7.1 I/O sticker



POWER PE (FE)	CG 35xxxxxx S/N A13xxxxx		KROHNE
	L(L+) N(L-)	 	
INPUT / OUTPUT	D - D	P	PULSE OUT / STATUS OUT I _{max} = 100 mA @ f ≤ 10 Hz ; = 20 mA @ f ≤ 12 kHz V _o = 1.5 V @ 10 mA; V _{max} = 32 VDC
	C - C	P	STATUS OUT I _{max} = 100 mA; V _{max} = 32 VDC
	B - B	P	STATUS OUT / CONTROL IN I _{max} = 100 mA V _{on} > 19 VDC, V _{off} < 2.5 VDC; V _{max} = 32 VDC
	A + A - A	A or P	CURRENT OUT (HART) Active (Terminals A & A+); R _{Lmax} = 1 kohm Passive (Terminals A & A-); V _{max} = 32 VDC

Figure 1-5: I/O sticker on cover of terminal compartment

Example of I/O sticker on the inside of the terminal compartment for modules;

- Fieldbus IO PA on IO board 1.
- Intrinsic safety option with current out active
- Pulse/Status Out/Control in on IO board 2

Other combinations are possible. See the approval description of the UFC 400 electronics unit

1.7.2 Nameplate for the measuring sensor (field version)

Examples for measuring sensor versions in HJ and XXT version.

⑦	KROHNE	Altometer, Dordrecht NL - 3313 LC	 II 2 G Ex ia IIC T6...T3 Gb DEKRA 13 ATEX 0092 X / IECEx DEK 13.0023X Ta= -40...+70 °C	①
	⑥	OPTISONIC 3000 F/ -Ex S/N: Axx xxxxx DN: xxx mm / xxx inch GK: xxx	CE 0344 Mfd: 20xx in the Netherlands PED/G1/xxx : PS1=40 bar @ TS1<=40°C PS2=32 bar @ TS2 =180°C PT =60 bar @ TT = 20°C	
⑤	IP66/67 acc. to EN 60529		MAXIMUM PROCESS TEMPERATURES: T6 (80°C) T4 (130°C) T5 (95°C) T3 (180°C) INTRINSICALLY SAFE SENSOR CIRCUITS: U _i = 13.1 V C _i ≤ 11.6 nF I _i = 600 mA L _i ≤ 134 μH	③
				④

Figure 1-6: Nameplate for the measuring sensor (field version)

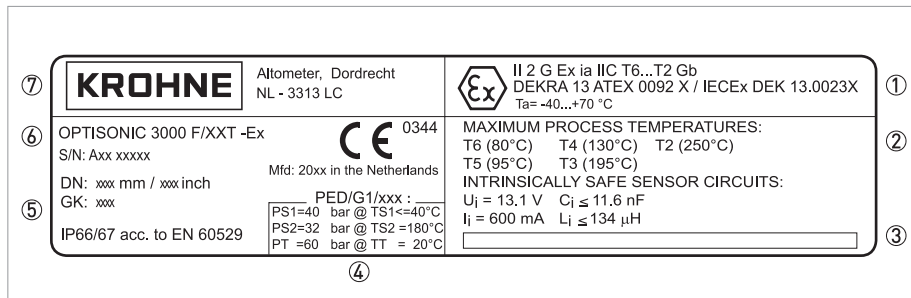

Figure 1-7: Nameplate for the measuring sensor (field version)

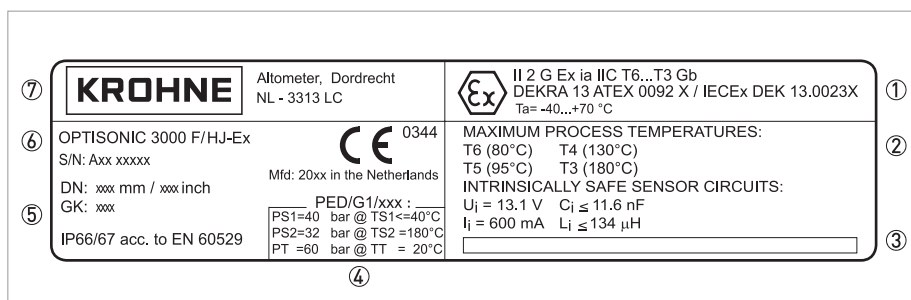

Figure 1-8: Nameplate for the measuring sensor (field version)

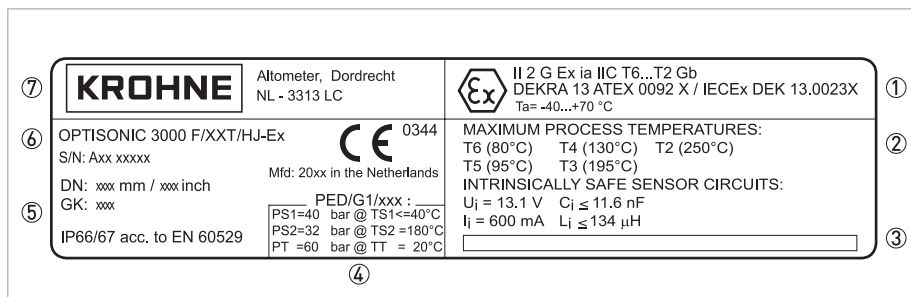

Figure 1-9: Nameplate for the measuring sensor (field version)

1. Specific sign for explosion protection, Ex codes and number of EC type examination certificate
2. Explosion safety notes
3. Tag number
4. PED data, type I / II / III or SEP
5. Calibration data
6. Type designation of the flowmeter and CE sign with number(s) of notified body / bodies
7. Name and address of the manufacturer

2.1 General

Due to the influence of the process medium temperature (and heating temperature for HJ-versions), ultrasonic flow sensors in field design with type designation OPTISONIC 3000 F/..Ex and ultrasonic compact flowmeters with type designation OPTISONIC 3400 C(/i)- Ex are not allocated to any fixed temperature class. See the temperature classification tables on the following page for more details. The temperature limits apply under the following conditions:

- The device is installed and operated in accordance with the installation directions given in the manual.
- The device is not heated up by any additional heat radiation (direct solar radiation, heat from adjacent plant parts) so causing it to operate above the permissible ambient temperature range.
- Insulation is not hindering free ventilation of the ultrasonic signal converter housing.

2.2 UFC 400 F(/i)-Ex

The UFC 400 F/...-Ex flow converter in remote design is suitable for ambient temperatures in the range -40 to +65°C when equipped with basic I/O and -40 to +60°C for all other I/O configurations.

The surface temperature always remains below 80°C. The flow converter in remote design is not influenced by the process temperature, because it is installed on a distance of the remote flow sensor. It therefore has a temperature rating of T6.

2.3 OPTISONIC 3400 C(/i)-Ex

The OPTISONIC 3400 C/...-Ex compact flowmeter is suitable for ambient temperatures in the range of -40...65°C, when equipped with basic I/O, and suitable for an ambient temperature range of -40...60°C for all the other I/O configurations.

The following temperature limitations should be maintained for the compact flowmeter with aluminum MH 300 housing and basic I/O.

Temperature classification OPTISONIC 3400 C-.. with aluminum MH 300 housing and basic I/O.

Temperature class	Maximum process temperature [°C] at ...			
	Ta ≤ 50°C	Ta ≤ 55°C	Ta ≤ 60°C	Ta ≤ 65°C
T6	80	80	80	40
T5	95	95	95	40
T4	130	130	95	40
T3	180	145	95	40

Temperature classification OPTISONIC 3400 C/i-.. with aluminum MH 300 housing and all other I/O configurations.

Temperature class	Maximum process temperature [°C] at ...			
	Ta ≤ 45°C	Ta ≤ 50°C	Ta ≤ 55°C	Ta ≤ 60°C
T6	80	80	75	25
T5	95	95	75	25
T4	130	130	75	25
T3	180	130	75	25

Temperature classification OPTISONIC 3400 C-.. with stainless steel MH 300 housing and basic I/O.

Temperature class	Maximum process temperature [°C] at ...					
	T _a ≤ 40°C	T _a ≤ 45°C	T _a ≤ 50°C	T _a ≤ 55°C	T _a ≤ 60°C	T _a ≤ 65°C
T6	80	80	80	80	65	30
T5	95	95	95	95	65	30
T4	130	130	130	105	65	30
T3	180	175	140	105	65	30

Temperature classification OPTISONIC 3400 C/i-.. with stainless steel MH 300 housing and all other I/O configurations.

Temperature class	Maximum process temperature [°C] at ...				
	T _a ≤ 40°C	T _a ≤ 45°C	T _a ≤ 50°C	T _a ≤ 55°C	T _a ≤ 60°C
T6	80	80	80	45	10
T5	95	95	80	45	10
T4	130	120	80	45	10
T3	155	120	80	45	10

2.4 OPTISONIC 3000 F/...-Ex

All the OPTISONIC 3000 F /...-Ex ultrasonic flow sensors in field version, are designed for an ambient temperature range of -40..+70°C.

The tables below shows the temperature classifications.

Temperature classification OPTISONIC 3000 F/... (default & LT / XXT).

Temperature class	Maximum process temperature [°C] at T _a = 70°C	
	OPTISONIC 3000 F-... & Cryogenic versions (LT)	OPTISONIC 3000 F & Extended temperature versions (XXT)
T6	80	80
T5	95	95
T4	130	130
T3	180	195
T2	n.a.	250

Temperature classification OPTISONIC 3000 F/.../HJ-... (with heating jacket).

Temperature class	Maximum process (& heating for HJ) temperature [°C] at T _a = 70°C	
	OPTISONIC 3000 F/HJ-...	OPTISONIC 3000 F/XXT/HJ-...
T6	80	80
T5	95	95
T4	130	130
T3	180	195
T2	n.a.	250

3.1 General

In the case of separate systems, the electrical connection between OPTISONIC 3000 F/...-Ex ultrasonic flow sensor and UFC 400 F...-Ex ultrasonic signal converter is established via a signal cable of type MR06-RG316. This cable consists of six coaxial cables surrounded by an additional screen and outer insulation layer. The ends of the coaxial cables are provided with SMB plugs. The signal cable is included with the field system by KROHNE.

3.2 Cable marking

The SMB plugs of the coaxial cables are marked by yellow tubing with a black number of subsequently 1.1, 1.2, 2.1, 2.2, 3.1 and 3.2. The first number represents the path 1, 2 or 3 and the second the transducer of that path (1 or 2). The marking of the SMB counter-plugs in the connection box of the signal converter is respectively 1.1, 1.2, 2.1, 2.2, 3.1 and 3.2. Also refer to *Signal cable connections (filed versions)* on page 17 for the connection of the several connection box types.

3.3 Cable parameters

The maximum permitted total capacitance and inductance for the connecting cable is:

C_L ; 1.29 μF or 0.79 μF

L_L ; 0.37 mH or 1.07 mH

The cable supplied by the manufacturer has the following parameters:

distributed capacitance C_C (core/screen) = 94 pF/m

distributed inductance L_C (core/screen) = 0.24 $\mu\text{H}/\text{m}$



INFORMATION!

The standard length of the signal cable is 5 m / 16.4 ft. In case a longer length is required, please contact your local representative for detailed information.



INFORMATION!

More than 30 m signal cable length is not recommendable, it will have a negative effect on the measuring accuracy.

3.4 Equipotential bonding

3.4.1 Signal converter

The UFC 400 F...-Ex ultrasonic signal converter **must always** be incorporated within the equipotential bonding system of the installation in the hazardous classified location. For this purpose it must be connected to the external U-clamp screw terminal (size M5) of the UFC 400 F converter.

The separate bonding conductor must be at least 4 mm² (11 AWG) or 2.5 mm² (14 AWG), in case it is mechanically protected, see Clause 413 of HD 384.4.41 or IEC 364-4-41. Make sure that the core of the bonding wire is properly mounted under the U-clamp of the PE-terminal and that the screw is tightly fixed.

The intrinsically safe transducer circuits of the UFC 400 F signal converter are galvanically isolated from earth, therefore an equipotential bonding conductor between the flow sensor (grounded intrinsically safe transducer circuits) and the signal converter (floating-intrinsically safe transducer circuits) does not have to be connected, but can be used if desired.



CAUTION!

When the ambient temperatures exceed 60°C / 140°F, the cables and cable gland used (for connection of the UFC 400F/...) must be suitable for at least 75°C / 167°F.

3.5 Signal cable connections (filed versions)

See the pictures below for details.

Electrical connection - Standard version

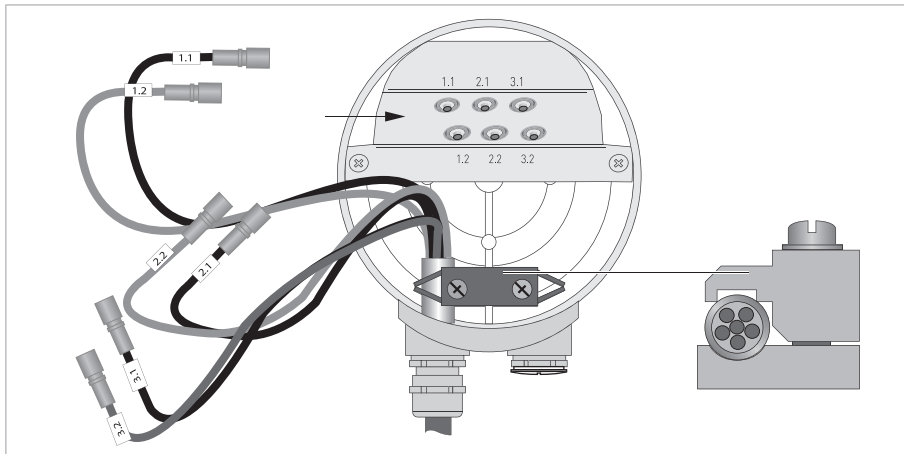

Figure 3-1: Connect the cables in the connection box of the flow sensor

Connection of flow sensor type Cryogenic and XXT

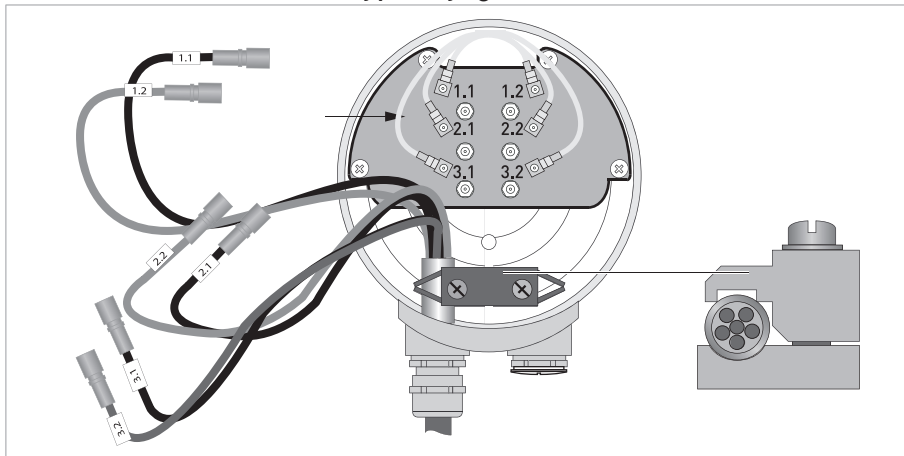

Figure 3-2: Connect the cables in the connection box of the flow sensor

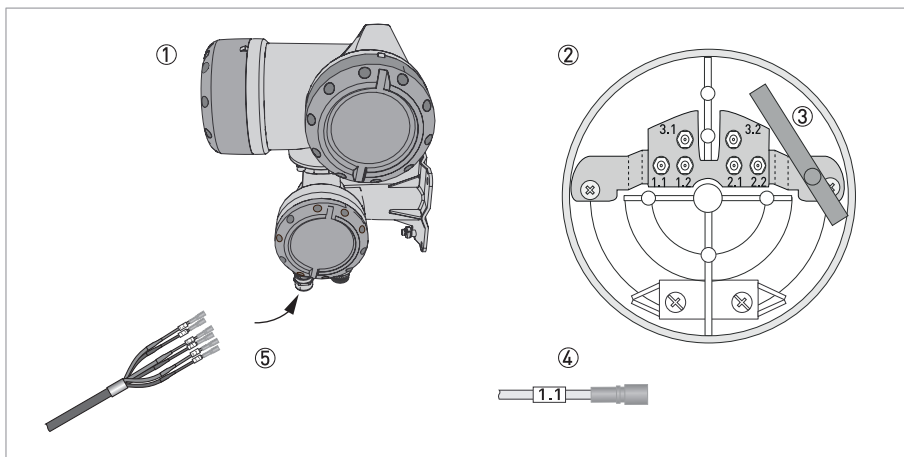

Figure 3-3: Construction of field version

- ① Signal converter
- ② Open connection box
- ③ Tool for releasing connectors
- ④ Marking on cable
- ⑤ Insert cable(s) into terminal compartment

4.1 General

The OPTISONIC 3400 C(/i) -Ex compact flowmeter and UFC 400 F(/i) -Ex signal converter (separate version) must be incorporated in the equipotential bonding system of the installation. This can be established internally by connection of the protective earth (PE) conductor of the mains supply system to the internal PE clamp, or externally, by connecting a separate equipotential bonding conductor to the external U-clamp terminal (size M5) at respectively the flange of the mounting support (in case of compact instruments) or at the mounting device (for signal converters in separate version). A separate bonding conductor must have a cross-sectional area of at least 4 mm².

The display cover seals the electronics compartment of the converter housing and provides type of protection "flameproof enclosure". The terminal compartment is default in type of protection "increased safety" ("Ex e") and can optionally be performed as flameproof enclosure ("Ex d"). The threaded joints formed by the covers and housing are a tight fit due to the requirements for type of protection "flameproof enclosure". Screw the covers on and off with care and never use excessive force !

Keep the screw-threads free of dirt and well-greased (e.g. with PTFE grease). The grease will help to prevent the threads from locking due to corrosion.

To unscrew the covers, first release the interlocking devices (one at each cover). Therefore unscrew the M4 head screw with internal hexagon socket set using a No. 3 Allen key until the interlocking device can be turned. After the covers are screwed back onto the housing, make sure that the interlocking devices are properly refitted.



WARNING!

Allow the electronics to de-energize before opening the electronics compartment of the flow converter housing. Wait at least 35 minutes for T6 and 10 minutes for T5 before opening.

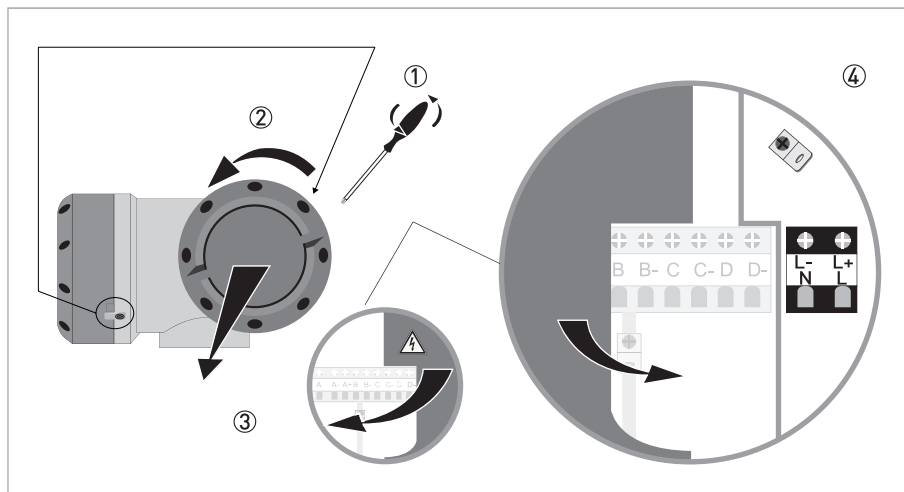

Figure 4-1: Electrical connections

- ① Unscrew interlocking head screw
- ② Turn cover counterclockwise and remove
- ③ Open / close safety lid of mains supply section
- ④ Mains supply & signal / data terminals

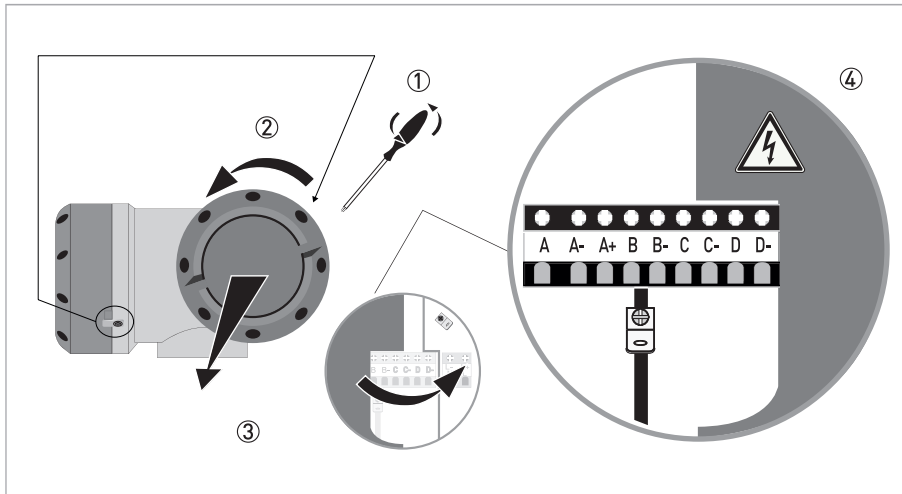

Figure 4-2: Electrical connections

- ① Unscrew interlocking head screw
- ② Turn cover counterclockwise and remove
- ③ Open / close safety lid of mains supply section
- ④ Mains supply & signal / data terminals

Terminals	Function, electrical data
L, N L+, L-	Connections for mains supply, always non-Ex i 100...230 V AC, +10%/-15%, 22 VA 12...24 V DC, +30%/-25%, 12 W 24 V AC, +10%/-15%, 22 VA 24 V DC, +30%/-25%, 12 W $U_m = 253 \text{ V}$
A, A-, A+ B, B- C, C- D, D-	Connections for signal I/Os (PELV circuits), non-“Ex i” or “Ex i”, are dependent on the specific version of the UFC 400 converter ordered. Consult the tables with CG35 numbers for details.

The exact I/O-configuration for circuits A, B, C and D is order-specific and can be determined by the CG35 number shown on the I/O sticker inside the terminal compartment. Therefore check the data on the back of the UFC 400 electronics unit. The CG35 number contains 10 characters of which the last three characters (XYZ) determine the configuration of the I/O circuits:

CG35	*	*	*	X	Y	Z
Pos 1...4	5	6	7	8	9	10
				determine I/O circuits		

For schematic overviews of the CG35 numbers, refer to *Non-“Ex i” I/O connections* on page 22 and refer to *“Ex i” I/O connections* on page 24. These overviews do not show all details. The exact connection diagram of a specific UFC 400 signal converter can be found on the sticker inside the terminal compartment.

4.2 Cable glands

The three cable entry holes in the MH-300-... housing have a M20x1.5 screw thread. Make sure that the custom selected cable glands and/or stopping plugs have the same screw thread.

For use in gaseous hazardous areas: the chosen cable glands and/or stopping plugs, must have the appropriate type of protection for the terminal compartment that is increased safety (Ex e) or flameproof enclosure (Ex d). They **MUST** be suitable for the conditions of use and correctly installed.

The flowmeter with the terminal compartment in type of protection increased safety "Ex e" is factory supplied with two "Ex e" approved cable glands and one "Ex e" approved blanking element (i.e. stopping plug).



WARNING!

When the terminal compartment performed as flameproof enclosure "Ex d", the MH 300-.. housing is supplied with one "Ex d" approved stopping plug and two temporary plugs. The temporary plugs are only intended for sealing the housing against entry of dust, moisture or else during transport, handling and storage. These temporary plugs must be replaced by suitable "Ex d" approved cable glands, stopping plugs or conduit adapters with sealing devices before the flowmeter is put into operation. Unused openings must be sealed by suitable certified plugs.

4.3 Field Wiring

The wiring of instruments has to be in accordance with the requirements as specified in the relevant national or international standard for electrical installations in hazardous areas, e.g. EN 60079-14. Section 9 (wiring systems) of this standard applies to all types of protection. Section 10 (additional requirements for type of protection "d" - flameproof enclosures), section 11 (additional requirements for type of protection "e" - increased safety) and section 12 (additional requirements for type of protection "i" - intrinsic safety) apply to respectively "Ex d", "Ex e" and "Ex i" performed connection (terminal) compartments.

4.4 Non-"Ex i" I/O connections

The following non-intrinsically safe I/O (inputs/outputs) are available:

I/O PCB	Input/output functions; $U_n < 32 \text{ V DC}$, $I_n < 100 \text{ mA}$, $U_m = 253 \text{ V}$
Basic I/O	Current Output, active or passive, with HART Status Output / Control Input Status Output Pulse / Status Output
Modular I/O	Current Output, active or passive, with HART Pulse / Status Output, active or passive, highC or Namur
Modular carrier with 1 or 2 I/O modules	Each module: 1 out of following 3 in-/output functions: Current Output, active or passive Pulse / Status Output, active or passive, highC or Namur Control Input, active or passive, highC or Namur
Fieldbus I/O	Foundation Fieldbus
	Profibus-PA
RS 485 Modbus	Modbus with or without termination

Notes:

- The options separated by "/" are software selectable (can be changed by the user).
- The options separated by "or" are hardware versions (must be ordered as such).
- All outputs are passive unless otherwise indicated.
- HighC means High Current input/output, Namur means that the in-/outputs are according to the NAMUR NE43 standard.

Overview of the possible combinations, defined by characters XYZ of the CG35 number					
Characters XYZ	Name of I/O circuits	Terminals A, A-, A+	Terminals B, B-	Terminals C, C-	Terminals D, D-
100	Basic I/O	CO CO(a) over A+	SO/CI	SO	PO/SO
488 to 4LL 588 to 5LL 688 to 6LL 788 to 7LL 888 to 8LL A88 to ALL B88 to BLL C88 to CLL	Modular I/O or Modular Carrier with 1 or 2 I/O modules	Many combinations possible			
D88	Fieldbus I/O Profibus PA	n.c.	n.c.	PA	PA
D8A to DLL	Fieldbus I/O Profibus PA with Module Carrier with 1 or 2 I/O modules	Many combinations possible		PA	PA
E88	Fieldbus I/O Foundation Fieldbus	n.c.	n.c.	FF	FF
E8A to ELL	Fieldbus I/O Foundation Fieldbus with Module Carrier with 1 or 2 I/O modules	Many combinations possible		FF	FF
G00 to GLL	RS485 Modbus	Many combinations possible		DP(a)	DP(a)
H00 to HLL	Modbus with 1 or 2 I/O modules			RS485	RS485
<p>Used abbreviations for in-/output functions: CO = Current Output, PO = Pulse Output, SO = Status Output, CI = Control Input, PA = Profibus PA, FF = Foundation Fieldbus, RS485 = RS485 Modbus, n.c. = not connected. All in-/outputs are passive unless otherwise noted as active with extension (a).</p>					

4.5 "Ex i" I/O connections

The following intrinsically safe I/O connections are available:

I/O PCB	I/O functions	
Ex i I/O	Current Output + HART communication Pulse / Status Output Current Output, active + HART communication	Ex ia IIC $U_i = 30 \text{ V}$, $I_i = 100 \text{ mA}$, $P_i = 1,0 \text{ W}$ $C_i = 10 \text{ nF}$, $L_i = \text{negligibly low}$ Ex ia IIC $U_o = 21 \text{ V}$, $I_o = 90 \text{ mA}$, $P_o = 0,5 \text{ W}$ Linear characteristics $C_o = 90 \text{ nF}$, $L_o = 2,0 \text{ mH}$ $C_o = 110 \text{ nF}$, $L_o = 0,5 \text{ mH}$
Ex i Option	Current Output Pulse / Status Output / Control Input Current Output, active	Ex ia IIC $U_i = 30 \text{ V}$, $I_i = 100 \text{ mA}$, $P_i = 1,0 \text{ W}$ $C_i = 10 \text{ nF}$, $L_i = \text{negligibly low}$ Ex ia IIC $U_o = 21 \text{ V}$, $I_o = 90 \text{ mA}$, $P_o = 0,5 \text{ W}$ Linear characteristics $C_o = 90 \text{ nF}$, $L_o = 2,0 \text{ mH}$ $C_o = 110 \text{ nF}$, $L_o = 0,5 \text{ mH}$
Fieldbus I/O	Profibus-PA Foundation Fieldbus	Ex ia IIC $U_i = 24 \text{ V}$, $I_i = 380 \text{ mA}$, $P_i = 5,32 \text{ W}$ $C_i = 5 \text{ nF}$, $L_i = 10 \mu\text{H}$ Suitable for connection to an intrinsically safe fieldbus in accordance with the FISCO model.

The I/O circuits titled "Ex i I/O" and "Ex i Option" are always provided with type of protection Intrinsic Safety (Ex ia). The I/O-circuits "Fieldbus I/O Profibus-PA" as well as "Fieldbus I/O Foundation Fieldbus" can be provided with type of protection Intrinsic Safety.

Up to a maximum of 4 intrinsically safe (Ex ia) in-/outputs are possible. All intrinsically safe circuits are galvanically isolated with respect to earth and each other. To avoid summation of voltages and current, the wiring of these "Ex ia"-circuits must be sufficiently separated, e.g. in accordance with the requirements of standard EN 60079-14, clause 12.2. The "Ex ia" in-/outputs may only be connected to other "Ex ia" or "Ex ib" approved devices (e.g. intrinsically safe isolation amplifiers), even if such devices are installed in a non-hazardous location !

Connection to non-"Ex i" devices, cancels the "Ex ia" properties of the flowmeter.

Terminals L and N (or L+ and L-) for connection of the mains supply are not available with type of protection "intrinsic safety". To achieve the necessary separation distances between the non-I.S. and I.S. according to EN 60079-11 between the non-"Ex i" and "Ex i" circuits, the mains terminals are provided with a semi-circular protection cover with a "snap-in" lock. This cover **MUST** be closed before establishing the power supply to the converter.



INFORMATION!

*For flow converters with an "Ex e" terminal compartment, installed in a Division 2, the non-incendive terminal compartment can be opened in an energized state for short periods of time, to access the intrinsically safe terminals for possible checks. However, the semi-circular insulation cover over the non-intrinsically safe mains supply terminals L and N (or L+ and L-) **MUST** be kept closed.*

Overview of possible "Ex ia" in-/outputs, defined by characters XYZ of the CG 35 numbers					
Characters XYZ	Name of I/O circuits	Terminals A, A-, A+	Terminals B, B-	Terminals C, C-	Terminals D, D-
200	Ex i I/O	n.c.	n.c.	CO(a)	PO/SO
300		n.c.	n.c.	CO	PO/SO
210	Ex i I/O with Ex i Option	CO(a)	PO/SO/CI	CO(a)	PO/SO
220		CO	PO/SO/CI	CO(a)	PO/SO
310		CO(a)	PO/SO/CI	CO	PO/SO
320		CO	PO/SO/CI	CO	PO/SO
D00	Fieldbus I/O Profibus PA	n.c.	n.c.	PA	PA
D10	Fieldbus I/O Profibus PA with Ex i Option	CO(a)	PO/SO/CI	PA	PA
D20		CO	PO/SO/CI	PA	PA
E00	Fieldbus I/O Foundation Fieldbus	n.c.	n.c.	FF	FF
E10	Fieldbus I/O Foundation Fieldbus with Ex i Option	CO(a)	PO/SO/CI	FF	FF
E20		CO	PO/SO/CI	FF	FF

Used abbreviations for in-/output functions: CO = Current Output, PO = Pulse Output, SO = Status Output, CI = Control Input, PA = Profibus PA, FF = Foundation Fieldbus, n.c. = not connected
All in-outputs are passive unless otherwise noted as active with extension (a).

5.1 Maintenance

The flowmeters are maintenance free with respect to the flowmetering properties. Within the scope of periodic inspections required for electrical equipment installed in hazardous areas it is recommended to check the flameproof converter housing and covers for signs of damage or corrosion.

For information about the flameproof joints please contact your KROHNE representative.

The four M6 bolts to screw the MH300-Ex housing have a strength of 700N/mm²

5.2 Before and after opening



WARNING!

the following instructions must always be carefully followed, if the housing of the signal converter has to be opened respectively closed again.

Before opening:

- Make absolutely sure that there is no explosion hazard!
- Make sure that all connecting cables are safely isolated from all external sources!
- Allow the electronics to de-energize before opening the electronics compartment of the converter housing. Wait at least 35 minutes for T6 and 10 minutes for T5 before opening.

When the instructions above are strictly followed, the display cover (includes glass window) of the electronics compartment may be removed. First unscrew the head screw with internal hexagon socket set (size M4) of the interlocking device by a No. 3 Allen key, until the cover can rotate freely.

After opening:

- Before the cover is screwed back onto the housing, the screw-thread must be clean and well-greased with an acid and resin-free grease, e.g. PTFE grease.
- Screw the cover as tight as possible onto the housing by hand, until it cannot be opened by hand anymore. Fixate the screw of the interlocking device tight with the No. 3 Allen key.

5.3 Replacement of mains fuse



WARNING!

Before commencing the work, refer to *Before and after opening* on page 26, then continue as follows:



- Pull the display unit of the mounting frame and turn display unit carefully aside.
- Unscrew the two screws size M4 that hold the mounting frame with the electronics unit.
- Carefully pull the mounting frame with electronics unit out of the housing, until the small printed circuit board with the six soldered coaxial cables can be pulled off of the sensor driver PC-board. Now carefully remove the unit from the housing, while keeping the small printed circuit board with coaxial cables down, close to the housing wall.
- The mains fuse is located in a fuse holder at the back-end of the electronics unit on the top printed circuit board (power supply PCB). The specifications must be as follows:

Fuse type: 5 x 20 mm (H) according to IEC 60127-2/V		
Power supply	Electrical data	KROHNE part number
12...24 V DC	250 V / 2 A	5060200000
24 V AC/DC	250 V / 2 A	5060200000
100...230 V AC	250 V / 0,8 A	5080850000



WARNING!

Before reassembling the unit, refer to *Before and after opening* on page 26, then:



- Reassemble the unit in reverse order.

5.4 Exchange of electronics unit

Important customer specific data should be documented before replacing the UFC 400 electronics unit. Under normal circumstances, the menu settings are stored on the backplane PC-board that is fixed inside the signal converter housing. When replacing the electronics unit, this information is automatically loaded into the new unit.

Contact KROHNE if:

- the unit to be replaced is damaged in such a way that the (customer) settings are lost.
- the new electronics unit contains a different (newer) software version that results in data error messages during start-up.



WARNING!

Before commencing the work, refer to Before and after opening on page 26, then continue as follows:



- Pull the display unit of the mounting frame and turn the display unit carefully aside.
- Unscrew the two screws size M4 that hold the mounting frame with the electronics unit.
- Carefully pull the mounting frame with electronics unit out of the converter housing, until the small printed circuit board with the four (default) or six (optional) soldered coaxial cables can be pulled off of the sensor driver PC-board (take care not to apply a large force on the circuit board while removing the connection board from the sensor driver board). Then remove the complete electronics unit from the housing.
- Check if the new electronics unit is undamaged and meets the same mains voltage specifications and in-/output properties.
- Carefully insert the new electronics unit until the small PC-board with six soldered coaxial cables can be clicked upon the sensor driver PC-board. Install the new unit completely into the housing and screw the two M4 screws. Put the display unit back onto the front of the mounting frame.



WARNING!

Before screwing the display cover back onto the housing, please refer to Before and after opening on page 26.

5.4.1 Field version

**DANGER!**

All work on the electrical connections may only be carried out with the power disconnected. Take note of the voltage data on the nameplate!

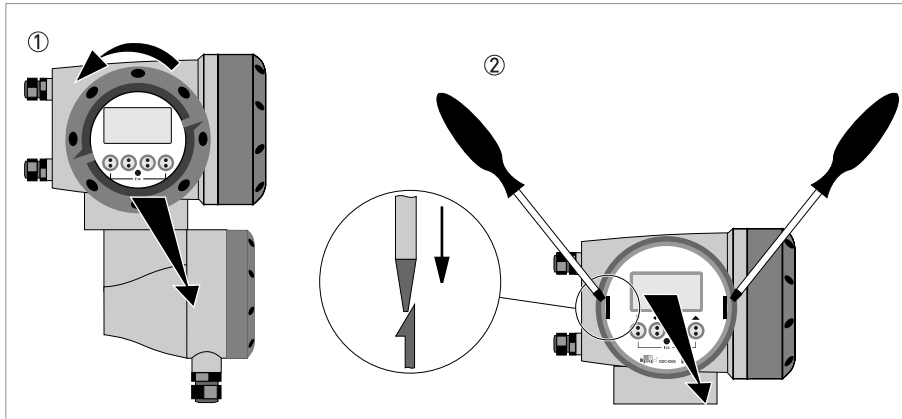

Figure 5-1: Unscrew the cover and remove the display

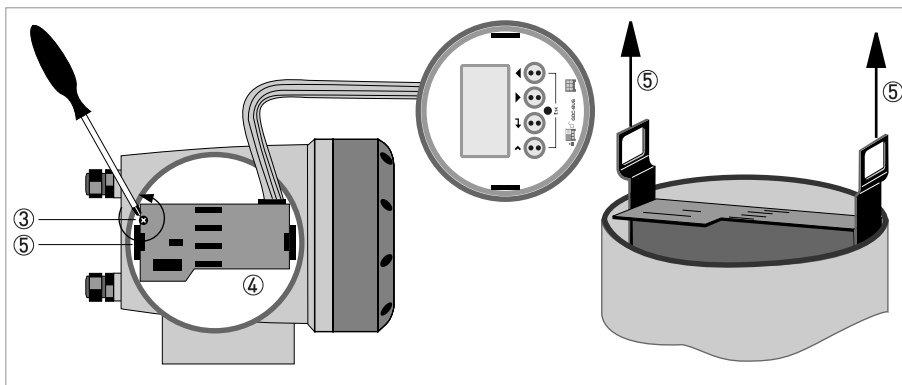

Figure 5-2: Pull off printed circuit board

**Perform the following procedures:**

- Unscrew the display cover of the electronics compartment by hand, by turning it counter clockwise ①.
- Remove the display by using two screwdrivers ②.
- Unscrew the two M4 screws ③ at the electronics unit ④.
- Pull the two metal pullers ⑤ at the left and right of the display, using a screwdriver or similar tool and partially pull out the electronics unit.

**CAUTION!**

Please pay attention that the same amount of force is applied on both pullers, otherwise the connector at the backside can be damaged.

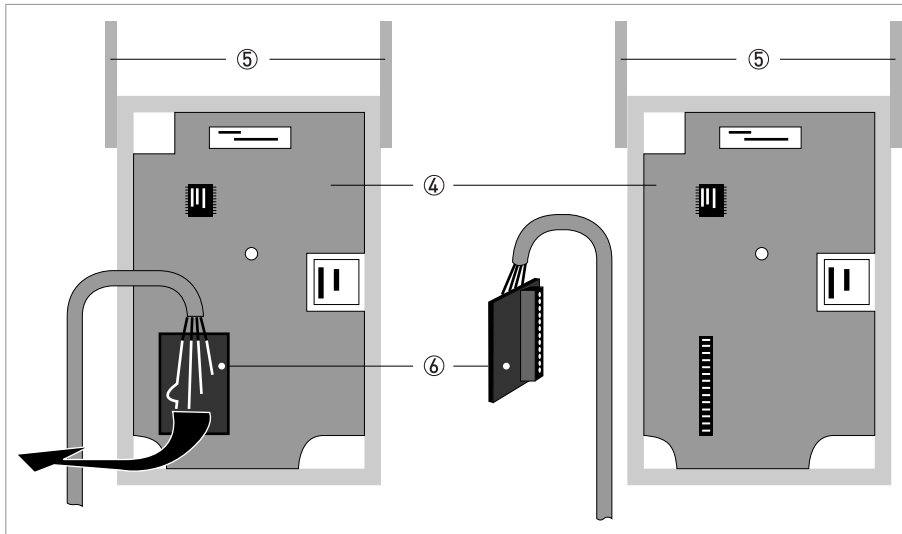

Figure 5-3: Small printed circuit board and electronics unit



DANGER!

Electrostatic discharge (ESD) can damage electronic parts. Make sure to discharge yourself by wearing a wrist strap. If no wrist strap is available, ground yourself by touching a metal surface that is grounded.



- Remove the printed circuit board ⑥ from the electronics unit ④.
- Check compatibility between the removed and new electronics unit ④, by checking the power voltage.
- Slide the new electronics unit ④ partially back into the housing.
- Mount the small printed circuit board back onto the electronics unit ④.
- Push the metal pullers ⑤ back to their original position.
Don't use excessive force, otherwise the connector at the backside can be damaged!
- Screw the electronics unit back to the housing.
- Re-install the display and make sure not to kink the display's flat ribbon cable.
- Replace cover and tighten by hand.
- Connect power.

5.5 Service / repair information

This device has been carefully manufactured and tested. If installed and operated in accordance with these operating instructions, it will rarely present any problems.



CAUTION!

Should you nevertheless need to return a device for inspection or repair, please pay strict attention to the following points:

- *Due to statutory regulations on environmental protection and safeguarding the health and safety of our personnel, the manufacturer may only handle, test and repair returned devices that have been in contact with products without risk to personnel and environment.*
- *This means that the manufacturer can only service this device if it is accompanied by the following certificate (see next section) confirming that the device is safe to handle.*



CAUTION!

If the device has been operated with toxic, caustic, flammable or water-endangering products, you are kindly requested:

- *to check and ensure, if necessary by rinsing or neutralizing, that all cavities are free from such dangerous substances,*
- *to enclose a certificate with the device confirming that is safe to handle and stating the product used.*

5.6 Form (for copying) to accompany a returned device

Company:		Address:	
Department:		Name:	
Tel. no.:		Fax no.:	
Manufacturer's order no. or serial no.:			
The device has been operated with the following medium:			
This medium is:	water-hazardous		
	toxic		
	caustic		
	flammable		
	We checked that all cavities in the device are free from such substances.		
	We have flushed out and neutralized all cavities in the device.		
We hereby confirm that there is no risk to persons or the environment through any residual media contained in the device when it is returned.			
Date:		Signature:	
Stamp:			

5.7 Disposal

**CAUTION!**

Disposal must be carried out in accordance with legislation applicable in your country.









KROHNE product overview

- Electromagnetic flowmeters
- Variable area flowmeters
- Ultrasonic flowmeters
- Mass flowmeters
- Vortex flowmeters
- Flow controllers
- Level meters
- Temperature meters
- Pressure meters
- Analysis products
- Products and systems for the oil & gas industry
- Measuring systems for the marine industry

Head Office KROHNE Messtechnik GmbH
Ludwig-Krohne-Str. 5
47058 Duisburg (Germany)
Tel.: +49 (0)203 301 0
Fax: +49 (0)203 301 10389
info@krohne.de

The current list of all KROHNE contacts and addresses can be found at:
www.krohne.com

KROHNE