



OPTIWAVE-M 7400 Supplementary Instructions

Supplementary Instructions for IECEx applications



1	General safety information	3
<hr/>		
1.1	Scope of the document	3
1.2	Device description	3
1.3	Standards and approvals.....	3
1.4	Equipment protection levels (EPL).....	4
1.5	IECEX nameplate	4
2	Installation	5
<hr/>		
2.1	Special conditions.....	5
2.2	Precautions.....	5
2.2.1	General notes.....	5
2.2.2	Electrostatic discharge	5
2.2.3	Optional purging system.....	7
2.2.4	Optional pressure transmitter.....	7
2.3	Operating conditions	8
2.3.1	Ambient and process connection temperatures.....	8
3	Electrical connections	10
<hr/>		
3.1	General notes	10
3.2	Terminal compartment	11
3.2.1	How to open the terminal compartment	11
3.2.2	How to close the terminal compartment	12
3.3	Terminal tightening capacity.....	12
3.4	Equipotential bonding system	13
3.5	How to connect the electrical cables	13
3.6	Maximum intrinsically safe values for the electrical circuit	14
3.7	Supply voltage	14
4	Start-up	15
<hr/>		
5	Service	16
<hr/>		
5.1	Periodic maintenance.....	16
5.2	Keep the device clean.....	16
5.3	How to remove the device	16
5.4	OPTIWAVE 8300: Replacement of the signal converter.....	17
5.5	Manufacturer	17
5.6	Returning the device to the manufacturer.....	18
5.6.1	General information.....	18
5.6.2	Form (for copying) to accompany a returned device.....	19

1.1 Scope of the document

These instructions are applicable only to the explosion-protection version of the radar level transmitter. For all other data, use the Quick Start and Handbook. If you do not have these documents, please contact the nearest office or download them from the manufacturer's internet site.

**INFORMATION!**

The information in these supplementary instructions only contains the data applicable to explosion protection. The technical data for the non-Ex version in the Handbook shall be valid in its current version, provided that it is not rendered invalid or replaced by these supplementary instructions.

**WARNING!**

Installation, commissioning and maintenance may only be carried out by "Personnel trained in explosion protection".

1.2 Device description

The OPTIWAVE-M 7400 measures level, volume, distance to surface and reflectivity of liquids, pastes and slurries.

Measurements are displayed via a DTM (device type manager) for remote communication or on an optional integrated display screen with wizard-driven setup.

The level transmitter is approved for use in potentially explosive atmospheres when equipped with the appropriate options.

An external transmitter, to measure process pressure, is optional.

1.3 Standards and approvals

**DANGER!**

In compliance with the IECEx scheme rules, the IECEx version of the device described in these Supplementary Instructions agrees with International Standards IEC 60079-0:2017, IEC 60079-11:2011 and IEC 60079-26:2014. The device is certified for use in hazardous areas by Kiwa ExVision B.V. under certificate of conformity IECEx KIWA 17.0012X.

**WARNING!**

Carefully read the IECEx certificate of conformity. Obey the boundary conditions.

You can download the certificate from our internet site.

1.4 Equipment protection levels (EPL)

The device has the markings that follow:

PP Drop antenna

- Ex ia IIC T6...T5 Ga/Gb

All other versions

- Ex ia IIC T6...T3 Ga/Gb

The device is suitable for use in potentially explosive atmospheres of all flammable substances in Gas Groups IIA, IIB and IIC. It is certified for applications requiring EPL Ga/Gb. The equipment is also applicable for applications that agree with EPL Gb or EPL Gc. It agrees with temperature classes T6 thru T1 if the temperature limits are obeyed. For more data, refer to *Ambient and process connection temperatures* on page 8.



INFORMATION!

The equipment must have EPL Ga/Gb if it is installed in the boundary wall between zone 0 and zone 1 (the antenna is in zone 0 and the signal converter is in zone 1).

1.5 IECEx nameplate

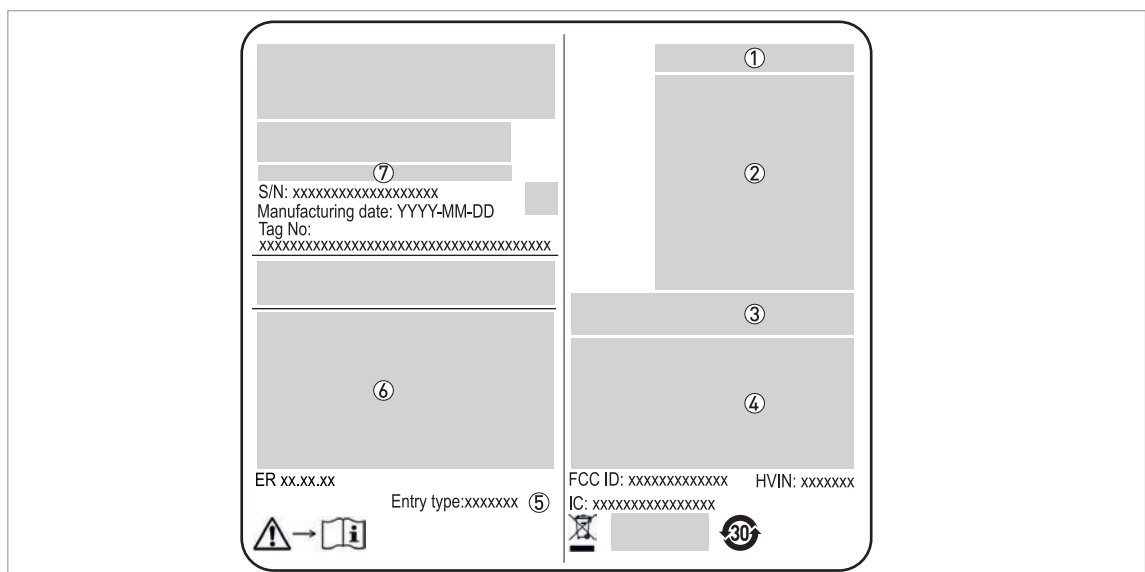

Figure 1-1: Nameplate on the signal converter housing

- ① IECEx certification number
- ② Types of device protection including approved Gas Groups, temperature classes and equipment protection level
- ③ Intrinsically safe circuit data. Refer to ⑥ for the input voltage range.
- ④ WARNING: Potential electrostatic charging hazard – see instructions
For more data, refer to *Electrostatic discharge* on page 5.
- ⑤ Cable entry type and size (M20×1.5, M25×1.5)
- ⑥ Input voltage range and maximum current
- ⑦ Type code

2.1 Special conditions

This device can be installed on the applicable auxiliary equipment: a bypass chamber, a stilling well or a communicating pipe.

2.2 Precautions

2.2.1 General notes



WARNING!

When you install the device, obey the conditions in the IECEx certificate of conformity. These conditions include:

- *The special conditions for safe use.*

You can download the certificate from our internet site.



DANGER!

This installation must agree with IEC 60079-14: Explosive atmospheres – Part 14: Electrical installations design, selection and erection.



DANGER!

The device contains a PTFE boundary wall between the process and the signal converter. Do not use the device if the PTFE part is not resistant to corrosion by the tank product.

Make sure that:

- you can get access to the device,
- there is sufficient space around the device for inspections,
- you can see the device nameplate, and
- there are no external forces applied on the device.

2.2.2 Electrostatic discharge



DANGER!

Risk of electrostatic discharge (ESD) from the Drop antenna and painted surfaces.

Do not install in a location where the electrostatic charge can increase. For example:

- locations near ventilation systems,
- locations where there is a risk of an increase in electrostatic charge caused by compressed air and dust,
- locations near machines that use friction,
- locations near systems that apply electrons as a spray (e.g. near electrostatic painting systems), and
- locations near other machines and systems that can have large electrostatic charges.



DANGER!

Make sure that the device and adjacent objects do not rub together.

Make sure that all personnel and equipment are correctly grounded.

If dirt collects on the device, clean it with a damp cloth.

ESD warning

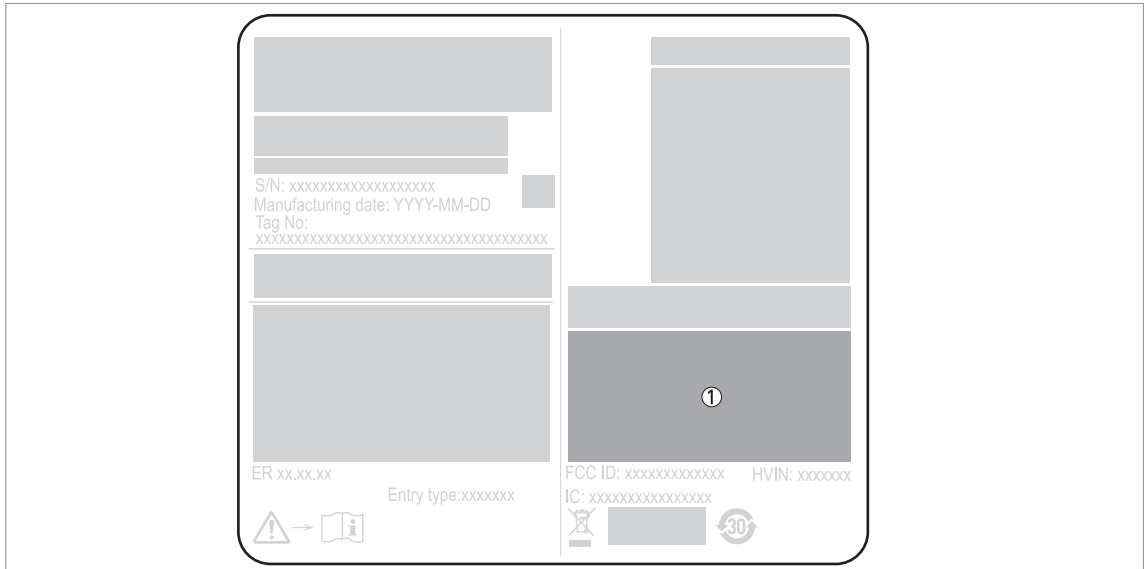

Figure 2-1: ESD warning (on the device nameplate)

① Text: Warning! Potential electrostatic hazard – see instructions

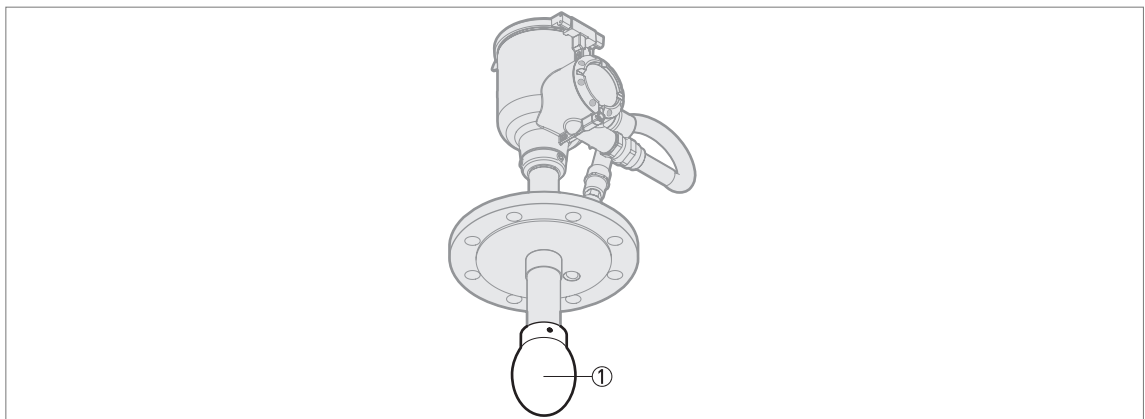

Figure 2-2: Risk of ESD

① Drop antenna

2.2.3 Optional purging system

This option is applicable to:

- devices that have horn antennas

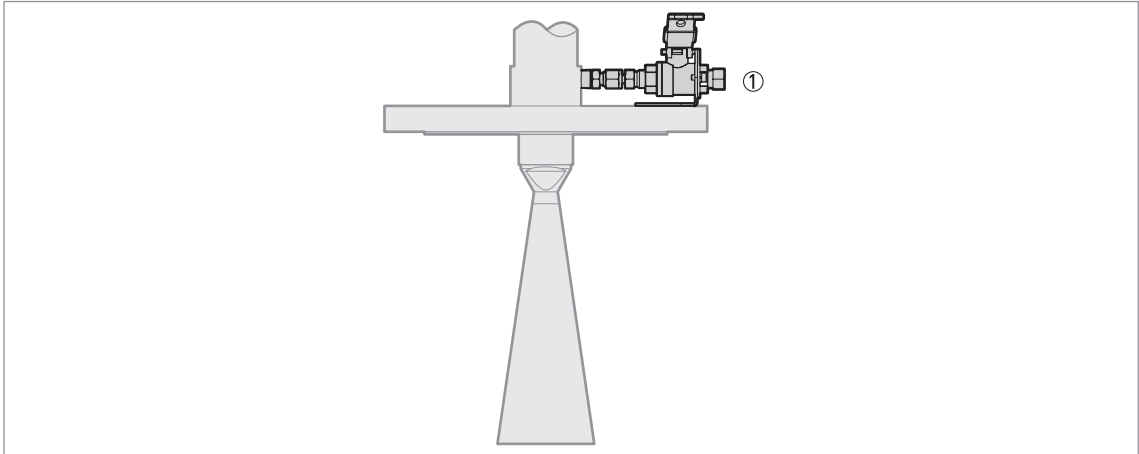

Figure 2-3: Purging system

① NPTF purging connection



INFORMATION!

If delivered with the device, the purging connection is plugged with a 1/4 NPTF screw and engaged on a minimum of 3½ threads.



CAUTION!

If the 1/4 NPTF screw is removed from the purging connection, make sure that the installation agrees with the Ex requirements for the purging system.

Connection and operation of the purging connection are the responsibility of the user. The operator is also responsible for selection of a suitable fluid to purge the device.

Devices installed in a gas atmosphere

- The purging fluid temperature must be less than the ignition temperature of the gas or vapour atmosphere
- The purging fluid temperature must be between the minimum and maximum limits for the gasket (for more data, refer to the handbook) and the type of antenna (for more data, refer to *Ambient and process connection temperatures* on page 8)

2.2.4 Optional pressure transmitter

If the device has the pressure transmitter option, it is attached to the flange with a threaded connection.



CAUTION!

If the device does not have the pressure transmitter option, the threaded hole in the flange is sealed with a screw plug. Do not remove this screw plug.

2.3 Operating conditions

The allowable ambient temperature and related process connection temperature range for the device depends on the temperature classes and maximum surface temperature marked on the nameplate.

2.3.1 Ambient and process connection temperatures



WARNING!

The gasket temperature must be in the approved limits. For more data, refer to "Pressure and temperature ranges" in the Installation chapter of the handbook. The type of gasket and gasket material must agree with the process.



WARNING!

The reference point for the process temperature is the flange facing of the device. In the tables that follow, this reference point will be referred to as the "process connection temperature".



WARNING!

An explosive atmosphere is a mixture of air and flammable gases, vapour, mist or dust in atmospheric conditions. If you do not use the device in these conditions ($T_{atm} = -20...+60^{\circ}\text{C}$ and $p_{atm} = 0.8...1.1 \text{ barg}$), do an analysis of the risk of ignition.

T_{atm} = atmospheric temperature and p_{atm} = atmospheric pressure.



WARNING!

Make sure that the maximum process connection temperature and maximum ambient temperature are not more than the values given in the tables.

The tables that follow are applicable in these conditions:

- Device installation must agree with the instructions given in the handbook.
- Make sure that the device temperature does not increase because of other heat sources (sunlight, adjacent system components etc.). The device must not be operated above the maximum permitted ambient temperature.
- Do not put insulation around the signal converter. Make sure that the airflow around the signal converter is sufficient. It is permitted to have insulation on the pipe or stilling well and the process connection.

Temperature class for EPL Ga/Gb, EPL Gb or EPL Gc	Maximum ambient temperature	Maximum process connection temperature (max. process temperature)
	[°C]	
T6	+60	+60
	+53	+85
T5	+75	+75
	+68	+100
T4 ①	+71	+115
	+65	+135
T3 ②	+62	+150
	+54	+180
	+49	+200

① Max. process connection temperature is +100°C, if the device has a PP Drop antenna

② Max. process connection temperature is +150°C, if the device has a PTFE Drop antenna

Temperature class for EPL Ga/Gb, EPL Gb or EPL Gc	Minimum ambient temperature	Minimum process connection temperature (min. process temperature)
	[°C]	
All classes ①	-40	-40

① Min. process connection temperature is -20°C, if a Kalrez® gasket is used

3.1 General notes



WARNING!

- *De-energize the circuit.*
- *Use the applicable cable glands for the cable entry openings in the housing (M20×1.5 or M25×1.5). For the cable entry size, refer to the device nameplate.*

3.2 Terminal compartment

3.2.1 How to open the terminal compartment



WARNING!

- Do not blow dust with compressed air if it collects on the housing. Clean the device with a damp cloth before you remove the terminal compartment cover.
- Make sure that no dust goes into the electrical compartment after you open the cover.

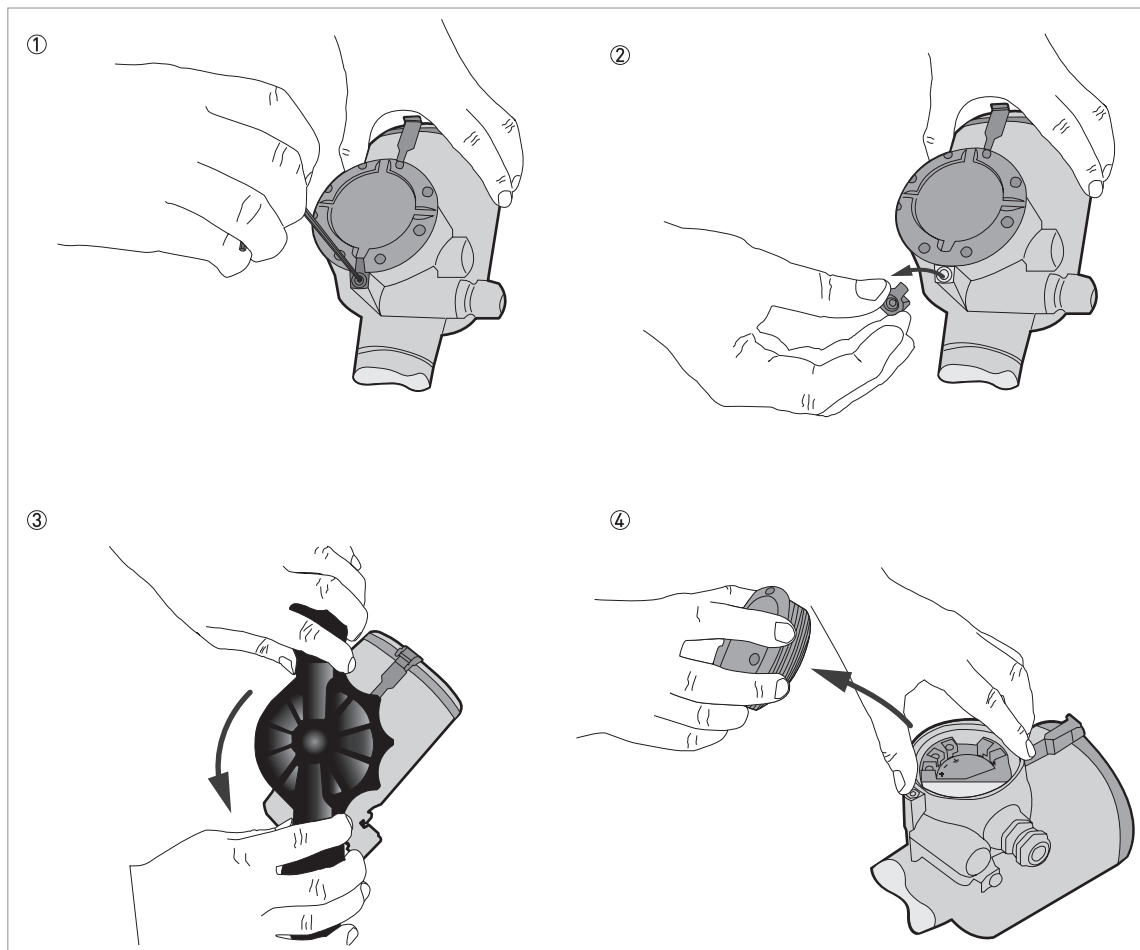

Figure 3-1: How to open the terminal compartment cover

Equipment needed

- Wrench (supplied)
- 3 mm Allen wrench (not supplied)



- Use the 3 mm Allen wrench to remove the cover stop.
- Use the wrench to remove the cover.

For more data about the procedure, refer to the handbook.

3.2.2 How to close the terminal compartment

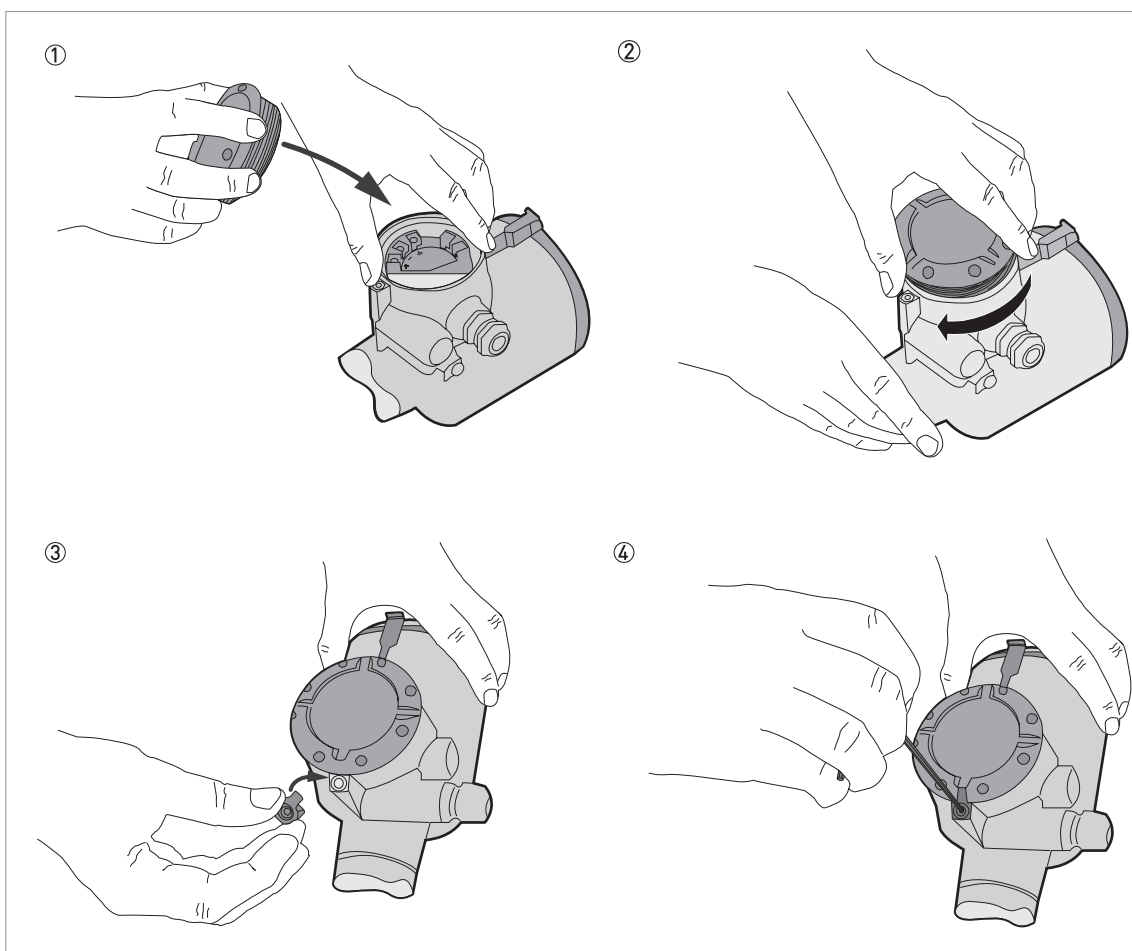

Figure 3-2: How to close the terminal compartment cover

Equipment needed

- Wrench (supplied)
- 3 mm Allen wrench (not supplied)



- Attach the cover. Make sure that a slot on the top of the cover is correctly aligned with the hole for the cover stop.
- Attach the cover stop (make sure that there is also a spring washer and a socket head screw). Tighten the screw with a 3 mm Allen wrench.

3.3 Terminal tightening capacity

The terminal tightening capacity of current output terminals is:

Type of wire	Terminal tightening capacity	
	[mm ²]	[AWG]
Flexible or rigid	2.5	13

3.4 Equipotential bonding system

Connect the device to the equipotential bonding system for the hazardous location.

You can use 2 terminals to connect the device to the equipotential bonding system:

- a ground connection in the terminal compartment and
- an external ground terminal adjacent to the cable entries

You can also use the process connection to connect the device to the equipotential bonding system. Make sure that there is a good electrical connection to the process connection (flange, thread etc.).

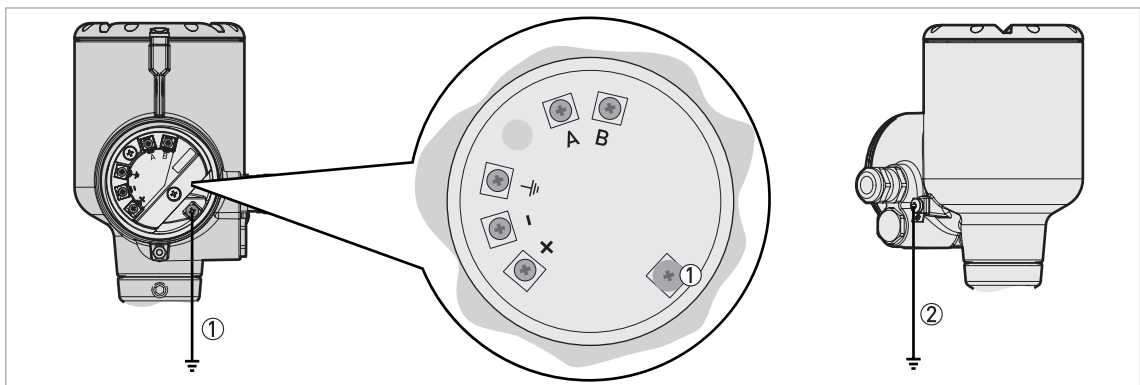

Figure 3-3: Examples of terminals for the equipotential bonding system

- ① Internal terminal
- ② External terminal (on the housing)

The device electronics are isolated with a rating of 500 V_{RMS}.

3.5 How to connect the electrical cables

Refer to the handbook for data about the device terminals.

Cable glands are supplied on customer demand. We recommend that you use a part that has a degree of ingress protection IP_{≥68}. Make sure that the cable gland is sealed.



Obey the instructions that follow:

- Electrical wires must agree with applicable standards (e.g. IEC 60079-14).
- Use the electrical connection procedure in the handbook.
- Put the electrical wires in position and safely attach them to prevent damage. The electrical wires must also be a sufficient distance from hot surfaces.
- Make sure that unused electrical wires are safely connected to the ground potential of the hazardous area. If this is not possible, make sure that each of the unused electrical wires are safely isolated (other electrical wires, ground etc.) and rated for a test voltage ≥ 500 V_{RMS}.
- If it is necessary, make sure the electrical wire insulation gives good protection from corrosion.
- Connect only to separate certified, intrinsically safe circuits. Make sure that the electrical circuit characteristics are not more than the values that follow.
- Do not remove more than 6 mm / 0.2" of insulation from the wire.

- The minimum thickness of the insulation must be 0.5 mm.



CAUTION!

Power supply:

Connect the electrical wires for the level transmitter to terminal "+" and "-". If your device has the optional pressure transmitter, connect electrical wires from the pressure transmitter to terminal "A" and "B".

3.6 Maximum intrinsically safe values for the electrical circuit

Level transmitter

Output	Intrinsically safe values for the electrical circuit				
	U_i	I_i	P_i	C_i	L_i
	[V]	[mA]	[W]	[nF]	[μ H]
4...20 mA passive – HART	≤30	≤130	≤1	=10	~ 0



WARNING!

Connect an intrinsically safe barrier to the level transmitter. If your device has the optional pressure transmitter, use a different intrinsically safe barrier for the pressure transmitter. These two intrinsically-safe circuits must be galvanically isolated. Make sure that the electrical wires are rated for a test voltage of 500 V_{RMS} .

Pressure transmitter (optional)

For the maximum intrinsically safe values, refer to the nameplate on the pressure transmitter.

3.7 Supply voltage

Level transmitter

Current output terminals	Minimum DC voltage at output terminals	Maximum DC voltage at output terminals
	[V]	
Terminals + / -	12	30

Pressure transmitter (optional)

For the power supply data, refer to the nameplate on the pressure transmitter.

**WARNING!**

Make sure that it is safe to supply electrical power. Do a start-up check:



- Are the wetted components (gasket, flange and antenna) resistant to corrosion by the tank product?
- Does the information given on the nameplate agree with the application?
- Did you connect the equipotential bonding system correctly?
- Are you using intrinsically safe barriers within the correct parameters? For more data, refer to *Maximum intrinsically safe values for the electrical circuit* on page 14. The electrical circuit characteristics must not be more than the maximum intrinsically safe values.
- Did you install the correct cable glands? Is the terminal compartment correctly sealed?
- Does the purging system agree with Ex requirements?

5.1 Periodic maintenance

In normal operational conditions, no maintenance is necessary. Only the manufacturer can repair the device and replace components. If it is necessary, maintenance must be done by approved personnel (the manufacturer or personnel approved by the manufacturer).



DANGER!

Do not open the device covers when the device is in an explosive atmosphere and energized.



CAUTION!

Do not replace an Ex i electronic block with a different block that is from a device which does not have an intrinsically safe barrier.

5.2 Keep the device clean

Obey these instructions:

- Keep the device clean to prevent dust contamination.
- Do not blow dust with compressed air.
- Clean the device with a damp cloth.



DANGER!

If dirt collects on the device, clean it with a damp cloth.

Do not use cleaning agents which can cause damage to the paint, the boundary wall (the PTFE process seal), the EPDM housing gaskets and the process connection gaskets (FKM/FPM or Kalrez®). Also make sure that the cleaning agent does not remove the data printed on the nameplate.

If you use the incorrect cleaning agent (i.e. the device is not resistant to corrosion by your cleaning agent), do not use the device in a hazardous location. If aid is necessary, speak or write to the supplier.

5.3 How to remove the device

The installation and removal of the device or the signal converter is a task for approved personnel (operator, fitter, electrician etc.). If you must change the signal converter or all of the device, refer to the procedures in the handbook.

If you must do work in a hazardous location:

- Disconnect the electrical wires. For more data refer to *How to open the terminal compartment* on page 11.
- Before you remove the device from the process connection, make sure that the tank is not pressurized. A pressurized tank can cause injury to persons when they do work on it.
- Make sure that all electrical wires are isolated from the ground. This is also applicable to Protective Earth (PE), Functional Earth (FE) and equipotential bonding conductors.

5.4 OPTIWAVE 8300: Replacement of the signal converter

You can replace the signal converter of an OPTIWAVE 8300 level transmitter that has an Ex approval that agrees with certificate of conformity IECEx KEM 06.0025X. But do the checks that follow:



DANGER!

Make sure that you use an intrinsically-safe barrier and electrical wires with the correct parameters. This data is given on the device nameplate of the new converter. Make sure that the signal converter was not installed in Zone 0 or Zone 20.



DANGER!

If an unserviceable OPTIWAVE 8300 has a Drop antenna, do not replace the signal converter. If it is necessary to replace the device, speak or write to your supplier.

You must attach an adaptor when you replace the signal converter with an OPTIWAVE-M 7400 signal converter. Use the spare parts list in the OPTIWAVE-M 7400 handbook to order the adaptor with the new signal converter.

If you replace the signal converter, the data (temperature, voltage etc.) given in these supplementary instructions agrees with the new device configuration.

5.5 Manufacturer

KROHNE S.A.S.
2 Allée des Ors – B.P. 98
26103 Romans-sur-Isère CEDEX
France

If you need to return your device for inspection or repair, speak or write to your supplier and obey the instructions that follow.

5.6 Returning the device to the manufacturer

5.6.1 General information

This device has been carefully manufactured and tested. If installed and operated in accordance with these operating instructions, it will rarely present any problems.



WARNING!

Should you nevertheless need to return a device for inspection or repair, please pay strict attention to the following points:

- *Due to statutory regulations on environmental protection and safeguarding the health and safety of the personnel, the manufacturer may only handle, test and repair returned devices that have been in contact with products without risk to personnel and environment.*
- *This means that the manufacturer can only service this device if it is accompanied by the following certificate (see next section) confirming that the device is safe to handle.*



WARNING!

If the device has been operated with toxic, caustic, radioactive, flammable or water-endangering products, you are kindly requested:

- *to check and ensure, if necessary by rinsing or neutralising, that all cavities are free from such dangerous substances,*
- *to enclose a certificate with the device confirming that it is safe to handle and stating the product used.*

5.6.2 Form (for copying) to accompany a returned device



CAUTION!

To avoid any risk for our service personnel, this form has to be accessible from outside of the packaging with the returned device.

Company:		Address:	
Department:		Name:	
Telephone number:		Email address:	
Fax number:			
Manufacturer order number or serial number:			
The device has been operated with the following medium:			
This medium is:	<input type="checkbox"/>	radioactive	
	<input type="checkbox"/>	water-hazardous	
	<input type="checkbox"/>	toxic	
	<input type="checkbox"/>	caustic	
	<input type="checkbox"/>	flammable	
	<input type="checkbox"/>	We checked that all cavities in the device are free from such substances.	
	<input type="checkbox"/>	We have flushed out and neutralized all cavities in the device.	
We hereby confirm that there is no risk to persons or the environment caused by any residual media contained in this device when it is returned.			
Date:		Signature:	
Stamp:			

KROHNE – Products, Solutions and Services

- Process instrumentation for flow, level, temperature, pressure measurement and process analytics
- Flow metering, monitoring, wireless and remote metering solutions
- Engineering, commissioning, calibration, maintenance and training services

Head Office KROHNE Messtechnik GmbH
Ludwig-Krohne-Str. 5
47058 Duisburg (Germany)
Tel.: +49 203 301 0
Fax: +49 203 301 10389
info@krohne.com

The current list of all KROHNE contacts and addresses can be found at:
www.krohne.com

KROHNE