



OPTIWAVE 1010 Supplementary instructions

Radar (FMCW) Level Transmitter for bypass chambers
and magnetic level indicators (BM 26 Advanced)

Supplementary Instructions for IECEx applications

1	General safety information	4
<hr/>		
1.1	Scope of the document	4
1.2	Device description	4
1.3	Standards and approvals.....	4
1.4	Equipment protection levels (EPL).....	5
1.4.1	Ex ia-approved devices	5
1.4.2	Ex db- and Ex tb-approved devices	5
1.5	IECEX nameplates	6
2	Installation	7
<hr/>		
2.1	Special conditions.....	7
2.2	Precautions.....	7
2.2.1	General notes.....	7
2.2.2	Electrostatic discharge	8
2.3	Operating conditions	9
2.3.1	Ambient and flange temperature	9
3	Electrical connections	11
<hr/>		
3.1	General notes	11
3.2	Terminal compartment	11
3.2.1	How to open the terminal compartment	11
3.2.2	How to close the terminal compartment	12
3.3	Terminal tightening capacity.....	12
3.4	Equipotential bonding system	13
3.5	Ex ia equipment	13
3.5.1	How to connect the electrical cables	13
3.5.2	Maximum intrinsically-safe values for the electrical circuit.....	14
3.5.3	Supply voltage	14
3.5.4	Electrical schematic	14
3.6	Ex db / Ex tb equipment.....	15
3.6.1	How to connect the electrical cables	15
3.6.2	Supply voltage	15
3.6.3	Electrical schematic	16
4	Start-up	17
<hr/>		
5	Service	18
<hr/>		
5.1	Periodic maintenance.....	18
5.2	How to clean the device.....	18
5.3	How to remove the device	19
5.4	Manufacturer	19
5.5	Returning the device to the manufacturer.....	20
5.5.1	General information.....	20
5.5.2	Form (for copying) to accompany a returned device.....	21

6 Notes

22

1.1 Scope of the document

These instructions are applicable only to the explosion-protection version of the radar level transmitter. If you do not have these documents, please contact the nearest office or download them from the manufacturer's internet site.

**INFORMATION!**

The information in these supplementary instructions only contains the data applicable to explosion protection. The technical data for the non-Ex version in the Handbook shall be valid in its current version, provided that it is not rendered invalid or replaced by these supplementary instructions.

**WARNING!**

Installation, commissioning and maintenance may only be carried out by "Personnel trained in explosion protection".

1.2 Device description

This device is an FMCW radar level meter designed for use with the BM 26 Advanced (a magnetic level indicator or MLI) or a bypass chamber. If the device is used with an MLI, it measures the distance to the float. If the device is used with a bypass chamber, it measures the distance to the surface of the liquid. Radar is a non-contact technology. Measurements are displayed via a DTM (device type manager) for remote communication.

The level meter is approved for use in potentially explosive atmospheres when equipped with the appropriate options.

1.3 Standards and approvals

**DANGER!**

In agreement with the IECEx scheme rules, the IECEx version of the device described in these Supplementary Instructions agrees with International Standards IEC 60079-0:2011, IEC 60079-1:2014, IEC 60079-11:2011, IEC 60079-26:2006, IEC 60079-31:2013. The Ex ia, Ex db and Ex tb versions are certified for use in hazardous areas by the Kiwa ExVision B.V. under KIWA 15.0012X.

**WARNING!**

Carefully read the IECEx approval certificate. Obey the boundary conditions.

1.4 Equipment protection levels (EPL)

1.4.1 Ex ia-approved devices

The Ex ia-approved device has the markings that follows:

- Ex ia IIC T6...T4 Ga/Gb;
- Ex ia IIC T6...T3 Ga/Gb;
- Ex ia IIIC T120°C Db

The Ex ia-approved device is suitable for use in potentially explosive atmospheres of all flammable substances in Gas Groups IIA, IIB and IIC when fitted with appropriate options. It is certified for applications requiring EPL of Ga/Gb or Gb equipment when fitted with the appropriate options. It agrees with temperature classes T6...T1.

EPL Ga/Gb equipment is used in zone 0, but it is installed in the boundary wall between zone 0 and zone 1 (the antenna is in zone 0 and the signal converter is in zone 1). EPL Gb equipment is used in zone 1.



WARNING!

Make sure that the installation of the device between zone 0 and zone 1 agrees with IEC 60079-26.

The Ex ia-approved device is suitable for use in potentially explosive atmospheres of all flammable substances in Dust Groups IIIA, IIIB and IIIC. It is certified for applications requiring EPL Db equipment when fitted with the appropriate options. The surface temperature of the device (without a layer of dust) cannot be more than +120°C / +248°F.

EPL Db equipment is used in zone 21.

1.4.2 Ex db- and Ex tb-approved devices

The Ex db- or Ex tb-approved device has the markings that follows:

- Ex db IIC T6...T4 Ga/Gb;
- Ex tb IIIC T120°C Db

The Ex db-approved device is suitable for use in potentially explosive atmospheres of all flammable substances in Gas Groups IIA, IIB and IIC. It is certified for applications requiring EPL Ga/Gb equipment or EPL Gb equipment when fitted with the appropriate options. It agrees with temperature classes T6...T1.

EPL Ga/Gb equipment is used in zone 0, but it is installed in the boundary wall between zone 0 and zone 1 (the antenna is in zone 0 and the signal converter is in zone 1). EPL Gb equipment is used in zone 1.

The Ex tb-approved device is suitable for use in potentially explosive atmospheres of all flammable substances in Dust Groups IIIA, IIIB and IIIC. It is certified for applications requiring EPL Db equipment when fitted with the appropriate options. The surface temperature of the device (without a layer of dust) cannot be more than +120°C / +248°F.

EPL Db equipment is used in zone 21.

1.5 IECEx nameplates

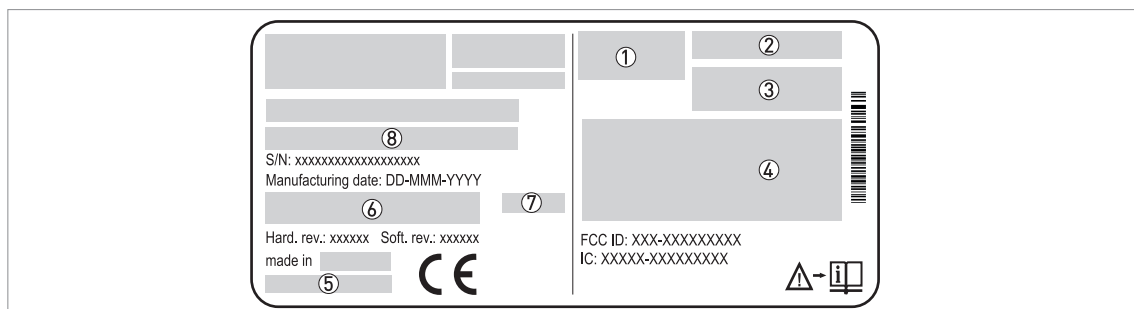

Figure 1-1: Nameplate on the signal converter housing

- ① Approval logo
- ② IECEx certification agency code
- ③ Types of device protection including approved Gas Groups, temperature classes and equipment protection level
Types of device protection including approved Dust Groups, maximum surface temperature and equipment protection level
- ④ **Ex ia approvals:** Intrinsically-safe circuit data
Ex db or Ex tb approvals: Maximum voltage in accordance with IEC 60079-0. Refer to ⑥ for the input voltage range.
- ⑤ Cable entry type and size (M20×1.5 or ½ NPT)
- ⑥ Input voltage range and maximum current (4...20 mA passive – HART)
- ⑦ Degree of ingress protection (if fitted with the appropriate cable glands)
- ⑧ Type code (defined in the "order code" section of the technical data sheet)

2.1 Special conditions

This device must be installed on the applicable auxiliary equipment: a bypass chamber, a stilling well or a communicating pipe.



CAUTION!

Do not install this device directly on the tank.

2.2 Precautions

2.2.1 General notes



WARNING!

When you install the device, obey the conditions in the IECEx approval certificate. These conditions include:

- *The special conditions for safe use.*
- *The Essential Health and Safety Requirements.*

You can download the certificate from our internet site.



DANGER!

This installation must agree with IEC 60079-14: Explosive atmospheres - Part 14: Electrical installations design, selection and erection.

Make sure that:

- you can get access to the device,
- there is sufficient space around the device for inspections
- you can see the device nameplate, and
- there are no external forces applied on the device.

2.2.2 Electrostatic discharge



DANGER!

Risk of electrostatic discharge from the painted surfaces of the aluminium housing. There is also a risk of electrostatic discharge if the stainless steel housing has painted surfaces.



DANGER!

Take the necessary antistatic precautions if:

- *you handle the device in potentially explosive atmospheres,*
- *you install the device in potentially explosive atmospheres or*
- *you use the device in potentially explosive atmospheres.*

Install the device correctly to prevent electrostatic discharge. Make sure that all equipment is correctly grounded.

Make sure that the housing and adjacent objects do not rub together.

If dirt collects on the device, clean it with a damp cloth.

Do not install in a location where the electrostatic charge can increase. This includes:

- locations near ventilation systems,
- locations where there is a risk of an increase in electrostatic charge caused by compressed air and dust,
- locations near machines that use friction,
- locations near systems that apply electrons as a spray (e.g. adjacent to electrostatic painting systems), and
- locations near other machines and systems that can have large electrostatic charges.

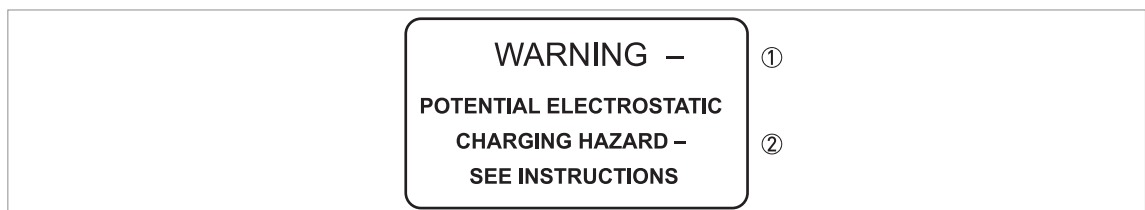

Figure 2-1: ESD warning sticker (below the device nameplate)

① Text: Warning

② Text: Potential electrostatic charging hazard – see instructions

2.3 Operating conditions

The allowable ambient temperature and corresponding flange temperature range for the device depends on the temperature classes marked on the nameplate.

2.3.1 Ambient and flange temperature

Because product temperature has an effect on the device, more than one temperature class is given. The temperature class is related to the product temperature and the temperature of the adjacent area.



WARNING!

The gasket temperature must be in the approved limits. The minimum gasket temperature is:

Gasket material	Minimum process connection temperature	
	[°C]	[°F]
EPDM	-40	-40
FKM/FPM	-40	-40
Kalrez® 6375	-20	-4

For more data, refer to "Pressure and temperature ranges" in the Installation chapter of the handbook.



WARNING!

If the device must operate at a high process temperature, make sure that the maximum flange temperature and maximum ambient temperature are not more than the values given in the table.



WARNING!

An explosive atmosphere is a mixture of air and flammable gases, vapour, mist or dust in atmospheric conditions. If you do not use the device in these conditions ($T_{atm} = -20...+60^{\circ}\text{C} / -4...+140^{\circ}\text{F}$ and $p_{atm} = 0.8...1.1 \text{ barg} / 11.60...15.95 \text{ psig}$), do an analysis of the risk of ignition.

T_{atm} = atmospheric temperature and p_{atm} = atmospheric pressure.

Words used in the tables:

- T_{amb} = ambient temperature
- T_m = process temperature
- T_F = process connection temperature
- Aluminium = the device with the aluminium housing option
- HT = high-temperature version of the device with the aluminium housing option
- Stainless steel = the device with the stainless steel housing option

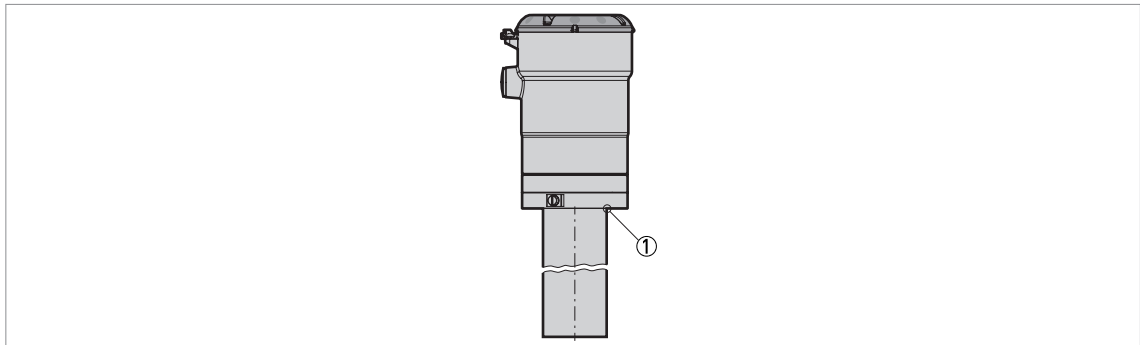

① Process connection temperature T_F



WARNING!

The maximum permitted product temperatures listed in the tables are applicable in these conditions:

- *The installation and operation of the device must agree with the handbook.*
- *Make sure that the device temperature does not increase because of other heat sources (sunlight, adjacent system components etc.). The device must not be operated above the maximum permitted ambient temperature.*
- *Do not put insulation around the signal converter. Make sure that the airflow around the signal converter is sufficient.*

Temperature class	Maximum process temperature or process connection temperature								Max. ambient temperature	
	Aluminium		HT		Stainless steel					
	Ex ia		Ex ia		Ex ia		Ex db			
	[°C]	[°F]	[°C]	[°F]	[°C]	[°F]	[°C]	[°F]	[°C]	[°F]
T6	+85	+185	+85	+185	+85	+185	+85	+185	+55	+131
T5	+85	+185	+100	+212	+90	+194	+90 ①	+194 ①	+70	+158
T4	+100	+212	+135	+275	+120	+248	+120	+248	+45	+113
	+95	+203	+135	+275	+100	+212	+100 ①	+212 ①	+60	+140
	+85	+185	+135	+275	+90	+194	+90 ①	+194 ①	+70	+158
T3...T1	+100	+212	+150	+302	+120	+248	+120	+248	+45	+113
	+95	+203	+150	+302	+100	+212	+100 ①	+212 ①	+60	+140
	+100	+212	+150	+302	+90	+194	+90 ①	+194 ①	+70	+158

① Use heat-resistant cables and cable glands certified for continuous operation above +90°C / +194°F

3.1 General notes



WARNING!

- De-energize the circuit.
- Use the applicable cable glands for the cable entry openings in the housing (M20×1.5 or ½ NPT). For the cable entry size, refer to the device nameplate.
- **Ex t- and Ex d-approved devices:** If ambient temperature <math><60^{\circ}\text{C}</math> / <math><140^{\circ}\text{F}</math>, use standard cables and cable glands certified for continuous operation above $+70^{\circ}\text{C}$ / $+158^{\circ}\text{F}$.
- **Ex t- and Ex d-approved devices:** If ambient temperature >math>>60^{\circ}\text{C}</math> / >math>>140^{\circ}\text{F}</math>, use heat-resistant cables and cable glands certified for continuous operation above $+90^{\circ}\text{C}$ / $+194^{\circ}\text{F}$.

3.2 Terminal compartment

3.2.1 How to open the terminal compartment



WARNING!

If dirt collects on the housing, clean the device with a damp cloth before you remove the terminal compartment cover.

How to open the Ex i terminal compartment

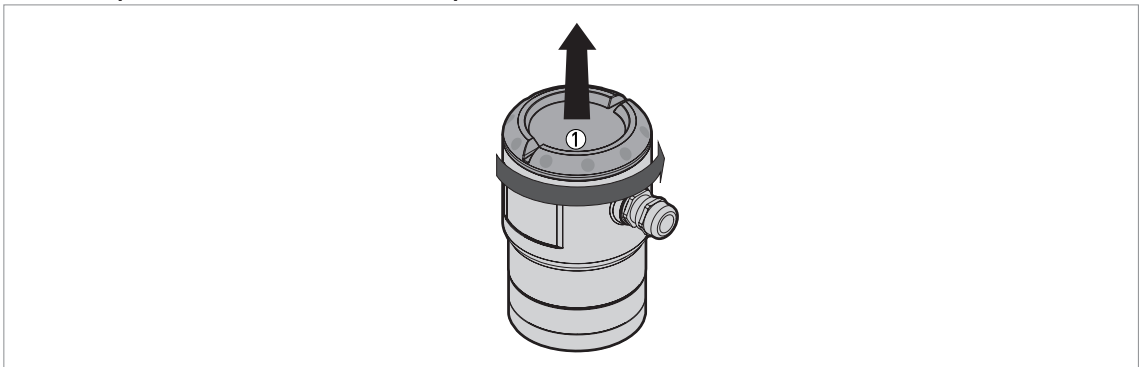

Figure 3-1: How to open the Ex i terminal compartment

- ① Terminal compartment cover

How to open the Ex d / Ex t terminal compartment

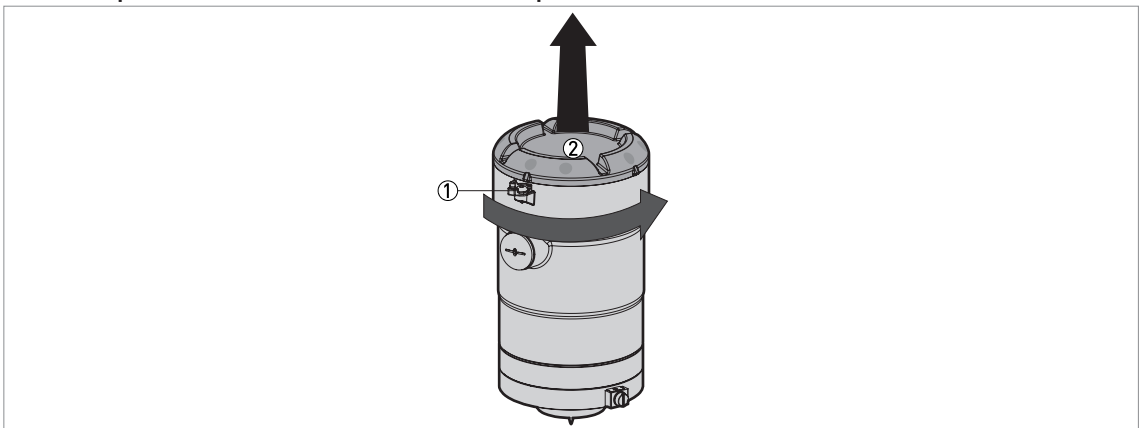

Figure 3-2: How to open the Ex d / Ex t terminal compartment

- ① Cover stop
② Terminal compartment cover

Equipment needed (not supplied)

- 2.5 mm Allen wrench.

**WARNING!****Ex d / Ex t applications**

Do not remove the terminal compartment cover while the electrical power is connected.



- De-energize the circuit.
- Remove the cover stop ①.
- ➡ Use a 2.5 mm Allen wrench.
- Remove the terminal compartment cover ②.

3.2.2 How to close the terminal compartment**Ex i applications**

- Attach the terminal compartment cover ②. Turn the terminal compartment cover carefully to prevent damage to the thread and the gasket.
- Make sure that the terminal compartment cover is tight.

**DANGER!****Ex d / Ex t applications**

Make sure that the terminal compartment is correctly sealed. An explosion can cause death or injury to personnel and/or damage to equipment. Obey the instructions that follow:

**Ex d / Ex t applications**

- Attach the terminal compartment cover ②. Turn the terminal compartment cover carefully to prevent damage to the thread and the gasket.
- Make sure that the terminal compartment cover is tight.
- Use a 2.5 mm Allen wrench to attach the cover stop ①.
- Make sure that the cover stop ① screw is tight.

3.3 Terminal tightening capacity

The terminal tightening capacity for the current output terminals is:

Type of wire	Terminal tightening capacity	
	[mm ²]	[AWG]
Rigid	4	11
Flexible	2.5	13

3.4 Equipotential bonding system

Connect the device to the equipotential bonding system for the hazardous location.

There are 2 terminals for connection to the equipotential bonding system:

- a ground connection in the terminal compartment and
- an external ground terminal at the bottom of the converter

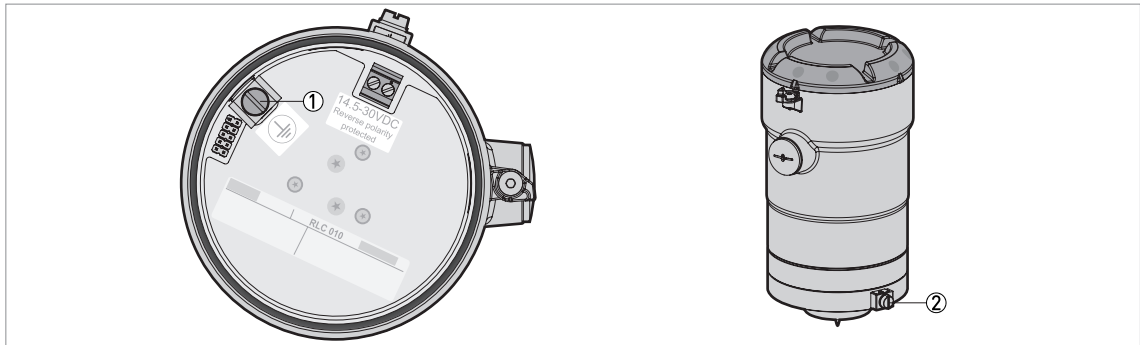

Figure 3-3: Terminals for the equipotential bonding system

- ① Ground connection in the terminal compartment
- ② External ground connection



INFORMATION!

Ground all remaining electrical wires in the hazardous location or make sure that they have good insulation. Electrical wires must not touch other wires or the ground. The device electronics are isolated with a rating of 500 V_{eff}.

3.5 Ex ia equipment

3.5.1 How to connect the electrical cables

Cable entries are supplied on customer demand. If you supply the cable entries, this part must have a degree of ingress protection IP_≥67 (IEC 60529). The electrical installation must agree with IEC 60079-14.

- Use the electrical connection procedure in the Handbook.
- Make sure that the wire is not in a location where it can be damaged. If it is necessary, make sure that the wire insulation gives good protection from corrosion.
- Make sure that the wiring does not touch the housing.
- Make sure that the wiring is not immediately adjacent to the housing.
- Supply the Ex i equipment connected to the device. Use only certified intrinsically-safe equipment.
- Make sure that you balance the electrical currents between different intrinsically-safe circuits.
- Cable glands supplied by the manufacturer keep dirt, water, or other unwanted materials out of the housing. Make sure that the ambient temperature of the cable glands is in the specified limits (T_{amb} = -40...+100°C / -40...+212°F). Make sure that the seals are tight.
- Connect only to separate certified, intrinsically-safe circuits. Make sure that the electrical circuit characteristics are not more than the values that follow.

- Do not remove more than 6 mm / 0.2" of insulation from the wire.

3.5.2 Maximum intrinsically-safe values for the electrical circuit

Output	Intrinsically-safe values for the electrical circuit				
	U _i	I _i	P _i	C _i	L _i
	[V]	[mA]	[mW]	[nF]	[μH]
4...20 mA passive – HART	≤30	≤130	≤1000	=10	~ 0

3.5.3 Supply voltage

	Minimum voltage at output terminals [VDC]	Maximum voltage at output terminals [VDC]
Current output terminals	14.5 ①	30 ①

① For a current output of 22 mA

3.5.4 Electrical schematic

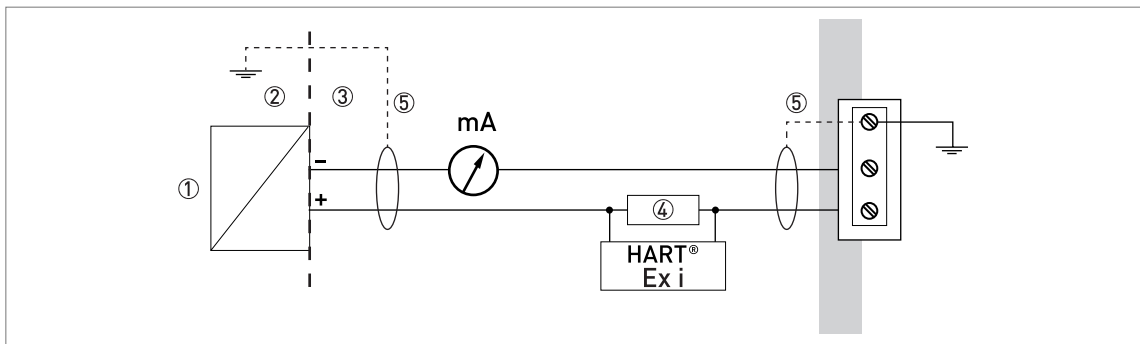

Figure 3-4: Electrical schematic for Ex ia-approved equipment

- ① Intrinsically-safe power supply
- ② Non-Ex zone
- ③ Ex zone
- ④ Resistor for HART® communication
- ⑤ Grounding wire – if the electrical wire is shielded (braided wire etc.)



INFORMATION!

For applications where EPL Gb is necessary, you must also connect the device to an intrinsically-safe circuit with protection concept "ib". If the device is connected to an intrinsically-safe circuit with protection concept "ia", the device operates with a higher level of safety.

3.6 Ex db / Ex tb equipment

3.6.1 How to connect the electrical cables

Cable entries are supplied on customer demand. If you supply the cable entries, this part must have a degree of ingress protection $IP \geq 67$ (IEC 60529).



WARNING!

If you use the device in potentially explosive atmospheres of all flammable substances in Gas Groups IIA, IIB and IIC, attach only Ex d-approved cable entries. If you use the device in potentially explosive atmospheres of all flammable substances in Dust Groups IIIA, IIIB and IIIC, attach only Ex t-approved cable entries.

Do not remove more than 6 mm / 0.2" of insulation from the wire.

Terminal compartment

- If you connect electrical wires to the terminals in the flameproof terminal compartment (volume, $V \leq 2000 \text{ cm}^3$), use approved flameproof cable glands (M20×1.5 or ½ NPT). The cable glands must have a test certificate that agrees with IEC 60079-1. Obey the instructions given on the test certificates. Make sure that that the tightening capacity of the cable entry is applicable to the diameter of the electrical wire.
- If you use conduits to connect electrical wires to the terminals in the flameproof terminal compartment, obey the instructions that follow. Make sure that the conduits are correctly attached and the flameproof compartment is sealed. The flameproof joint must have a minimum thread length of 8 mm / 0.32". The conduits must have a test certificate that agrees with . Use conduit stopping boxes that agree with precautions given in the test certificate and data in standards related to the installation of the conduit.
- If you connect electrical wires to the terminals in the dustproof terminal compartment, use approved flameproof cable glands (M20×1.5 or ½ NPT). The cable glands must have a test certificate that agrees with IEC 60079-31. Obey the instructions given on the test certificates. Make sure that that the tightening capacity of the cable entry is applicable to the diameter of the electrical wire.

Electrical wiring

- The electrical wiring must agree with the applicable standards (e.g. IEC 60079-14 / VDE 0165) and the maximum process temperature.
- Make sure that the wiring does not touch the housing.
- Make sure that the wiring is not immediately adjacent to the housing.
- Make sure that the wire is not in a location where it can be damaged. If it is necessary, make sure that the wire insulation gives good protection from corrosion.

3.6.2 Supply voltage

	Minimum voltage at output terminals [VDC]	Maximum voltage at output terminals [VDC]
Current output terminals	14.5 ①	32 ①

① For a current output of 22 mA

3.6.3 Electrical schematic

**DANGER!**

Keep the grounding wire a minimum distance of 2 mm / 0.83" away from the output terminals.

**CAUTION!**

Make sure that you connect the load resistor to the positive side.

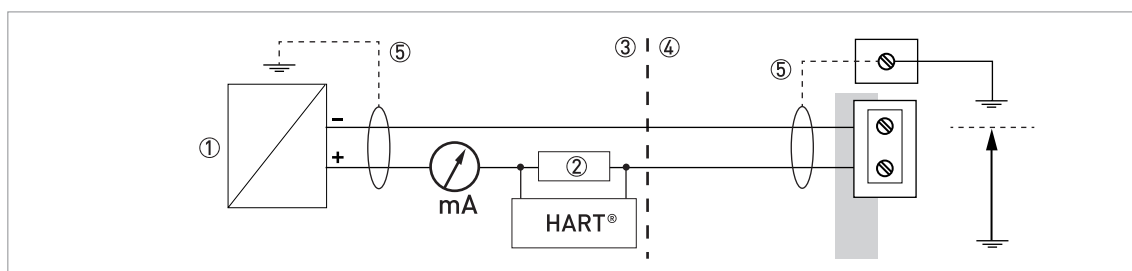

Figure 3-5: Electrical schematic for Ex db / Ex tb-approved equipment

- ① Power supply
- ② Resistor for HART® communication
- ③ Non-Ex zone
- ④ Ex zone
- ⑤ Grounding wire –if the electrical cable is shielded (braided wire etc.)

**WARNING!**

Make sure that it is safe to supply electrical power. Do a start-up check:



- Are the wetted components (gasket, flange and antenna) resistant to corrosion by the tank product?
- Does the data given on the device nameplate agree with the application and the process conditions?
- Did you connect the equipotential bonding system correctly?
- **Ex d applications:** Are the cable entries, plugs and adaptors Ex d-approved?
- **Ex t applications:** Are the cable entries, plugs and adaptors Ex t-approved?
- Are you using an intrinsically-safe barrier within the correct parameters? For more data, refer to *Ex ia equipment* on page 13. The electrical circuit characteristics must not be more than the maximum intrinsically-safe values.
- Did you install the correct cable entries? Is the terminal compartment correctly sealed?
- Make sure that the installation and wiring agree with local regulations.

**WARNING!**

Use the device only in the specified measuring range.

5.1 Periodic maintenance

In normal operational conditions, no maintenance is necessary. If it is necessary, maintenance must be done by approved personnel (the manufacturer or personnel approved by the manufacturer).

We recommend that you do regular inspections:

- Do a check of the housing cable entries and electrical wires for damage and corrosion.
- Make sure that the process connection and the signal converter are not clogged if there is a risk that dust will collect in recesses.
- Make sure that the process connection is sealed.
- Make sure that the device is included in process pressure tests.



WARNING!

Do not try to repair flameproof joints. If it is necessary to repair a flameproof joint, speak or write to your supplier.



WARNING!

Stainless steel housing with an Ex db or Ex tb approval

If you replace the signal converter, you must also replace the 4 screws below the process connection that hold the signal converter on the bypass chamber. The screws are supplied with the new signal converter by the manufacturer. For the part reference, refer to item ②c in the "Appendix: Spare parts" section of the handbook. These 4 screws are M6x35 hex socket head cap screws (external thread tolerance class: 6g), are made of A4-70 stainless steel, and agree with International Standard ISO 4762.

5.2 How to clean the device



DANGER!

If dirt collects on the device, clean it with a damp cloth.

5.3 How to remove the device

The installation and removal of the device or the signal converter is a task for approved personnel (operator, fitter, electrician etc.). If you must change the signal converter or all the device, refer to the procedures in the handbook. It is not necessary to remove the matching element from the process connection.

If you must do work in a hazardous location:

- Before you open the flameproof or dustproof terminal compartment, de-energize the device.
- Make sure that all electrical wires are isolated from the ground. This is also applicable to Protective Earth (PE), Functional earth (FE) and equipotential bonding conductors.
- Apply grease to dry housing cover seals after you open the terminal compartment. Use a multi-purpose grease (e.g. NONTRIBOS® Li EP2).
- Close the housing cover immediately after maintenance. Make sure that the housing is sealed.

When you attach the signal converter, use a 5 mm Allen wrench to tighten the hex head screws on the matching element to 8 N·m / 5.9 lbf·ft. If you changed the device, use a 6 mm Allen wrench to tighten the hex head screws of the Metaglas® component on the pipe connection to 20 N·m / 14.8 lbf·ft.

5.4 Manufacturer

This device is made by:

KROHNE S.A.S.
2 Allée des Ors – B.P. 98
26103 Romans-sur-Isère CEDEX
France

If you need to return your device for inspection or repair, obey the instructions that follow.

5.5 Returning the device to the manufacturer

5.5.1 General information

This device has been carefully manufactured and tested. If installed and operated in accordance with these operating instructions, it will rarely present any problems.



CAUTION!

Should you nevertheless need to return a device for inspection or repair, please pay strict attention to the following points:

- *Due to statutory regulations on environmental protection and safeguarding the health and safety of the personnel, the manufacturer may only handle, test and repair returned devices that have been in contact with products without risk to personnel and environment.*
- *This means that the manufacturer can only service this device if it is accompanied by the following certificate (see next section) confirming that the device is safe to handle.*



CAUTION!

If the device has been operated with toxic, caustic, flammable or water-endangering products, you are kindly requested:

- *to check and ensure, if necessary by rinsing or neutralising, that all cavities are free from such dangerous substances,*
- *to enclose a certificate with the device confirming that is safe to handle and stating the product used.*

5.5.2 Form (for copying) to accompany a returned device

**CAUTION!**

To avoid any risk for our service personel, this form has to be accessible from outside of the packaging with the returned device.

Company:		Address:	
Department:		Name:	
Tel. no.:		Fax no. and/or Email address:	
Manufacturer's order no. or serial no.:			
The device has been operated with the following medium:			
This medium is:	radioactive		
	water-hazardous		
	toxic		
	caustic		
	flammable		
	We checked that all cavities in the device are free from such substances.		
	We have flushed out and neutralized all cavities in the device.		
We hereby confirm that there is no risk to persons or the environment through any residual media contained in the device when it is returned.			
Date:		Signature:	
Stamp:			







KROHNE – Process instrumentation and measurement solutions

- Flow
- Level
- Temperature
- Pressure
- Process Analysis
- Services

Head Office KROHNE Messtechnik GmbH
Ludwig-Krohne-Str. 5
47058 Duisburg (Germany)
Tel.: +49 203 301 0
Fax: +49 203 301 10389
info@krohne.com

The current list of all KROHNE contacts and addresses can be found at:
www.krohne.com

KROHNE