



OPTIWAVE 7300 C Supplementary instructions

Non-contact Radar (FMCW) Level Meter for liquids

Supplementary Instructions for FOUNDATION Fieldbus communication



1	General safety information	3
<hr/>		
1.1	Scope of the document.....	3
1.2	Device description	3
1.3	Scope of delivery.....	3
2	FOUNDATION Fieldbus data	4
<hr/>		
3	Electrical connections	5
<hr/>		
3.1	Electrical installation: terminals	5
3.2	Electrical connection: PACTware™.....	6
4	Operation	7
<hr/>		
4.1	Description of device data	7
4.1.1	Resource block	7
4.1.2	Transducer block	7
4.1.3	Measurement data.....	8
4.1.4	Status data	8
5	Notes	9
<hr/>		

1.1 Scope of the document

These instructions are applicable only to the radar level transmitter with the FOUNDATION Fieldbus communication option. For all other data, use the Quick Start and other chapters of the Handbook. If you do not have these documents, please contact the nearest office or download them from the manufacturer's internet site.



INFORMATION!

The information in this chapter only contains the data applicable to FOUNDATION Fieldbus communication. The technical data in the Handbook shall be valid in its current version, provided that it is not rendered invalid or replaced by this supplement.

1.2 Device description

This device is a 4-wire level transmitter that uses FMCW (Frequency-Modulated Continuous Wave) radar technology. It measures level, volume, distance to surface, and reflectivity of liquids, pastes and slurries. It is suitable for installation on storage tanks, process tanks and stilling wells. Measurements are displayed via a DTM (device type manager) for remote communication or on an optional integrated display screen with wizard-driven setup and online help functions.

The level transmitter is approved for use in potentially explosive atmospheres when equipped with the appropriate options.

1.3 Scope of delivery

The information in this chapter only contains the data applicable to FOUNDATION Fieldbus communication. The technical data in the Handbook shall be valid in its current version, provided that it is not rendered invalid or replaced by this supplement.

A device for FOUNDATION Fieldbus communication is supplied with

- Supplementary Instructions for FOUNDATION Fieldbus communication
- Device description (DD) and capability (CCF) files on a CD-ROM supplied with the device

**INFORMATION!**

- The data that follows is applicable only for fieldbus communication networks. For general data, refer to the handbook.
- Additional information (certificates, special tools, software, files...) and complete product documentation is on the CD delivered with the device or can be downloaded free of charge from the website (Downloadcenter).

Description

Type	FMCW radar level transmitter
Output signal	Digital signal that agrees with the FF communication protocol
Test status	Registered

Data blocks

Registered features	Alarms, events, function blocks, linking and trending
Registered function blocks	1 x Resource Block (RB)
	4 x Analog Input Blocks (RB)
Other blocks	1 x Transducer Block (TB)
Communication Standard	Foundation Fieldbus protocol that agrees with IEC 61158-2
ITK version	5.1

Physical layer

Protocol	Foundation Fieldbus protocol that agrees with IEC 61158-2, galvanically isolated
Physical layer types	Standard power signaling, bus powered, non I.S.
Other features	Bus interface with integrated reverse polarity protection

Electrical connections

Device power supply (24 V input)	18...30 VDC
Current consumption on FOUNDATION Fieldbus network	20 mA

Input and output

Output data	Level, distance, level conversion, level mass, reflection, ullage conversion or distance mass
Input data	None
Error current FDE	Typically 0 mA (FDE =Fault Disconnection Electronic)
Link Master function	Not supported

3.1 Electrical installation: terminals

Electrical connection must agree with IEC 61158-2.

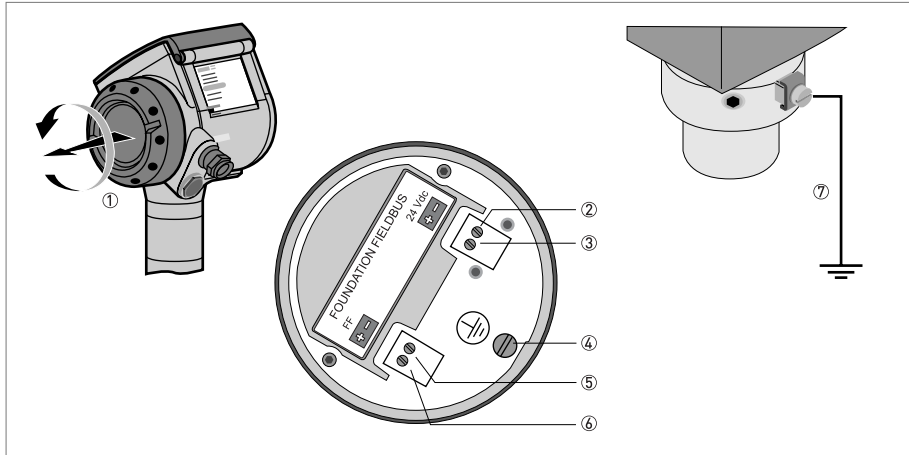

Figure 3-1: Electrical installation

- ① Terminal compartment cover
- ② Power supply terminal: 24 VDC -
- ③ Power supply terminal: 24 VDC +
- ④ Grounding terminal in the housing
- ⑤ Communication terminal: -
- ⑥ Communication terminal: +
- ⑦ Grounding terminal between the process connection and the converter



INFORMATION!

The **FF** terminal is connected to a *Fieldbus Power Hub*. The **24 VDC** terminal energizes the device.



Procedure:

- Remove the housing terminal compartment cover ①.
- Connect the FF segment to the communication terminals ⑤ and ⑥ of the device. Obey the national electrical codes and fieldbus specifications for communication networks.
- Make sure that the polarity of the wires is correct.
- Connect the power supply to the power supply terminals ② and ③ of the device. Obey the national electrical codes.
- Make sure that the polarity of the wires is correct.
- Attach the ground to ④ or ⑦. Both terminals are technically equivalent.

3.2 Electrical connection: PACTware™

**CAUTION!**

Before you use PACTware™ to configure the device, disconnect the device from the FOUNDATION Fieldbus segment.

**CAUTION!**

The HART address of the device must be set to "1". If the device is not set to "1", the device will not operate in FOUNDATION Fieldbus networks. Refer to the Handbook for more data on how to change the HART address.

PACTware™ is an Open Source, open configuration software for all field devices. Use PACTware™ to configure your device. For more data, refer to "Start-up" in the handbook.

Attach a HART® converter to the terminals shown in the illustration that follows. We recommend the VIATOR converter that is available as an accessory for this device. Refer to the Handbook for more data on accessories.

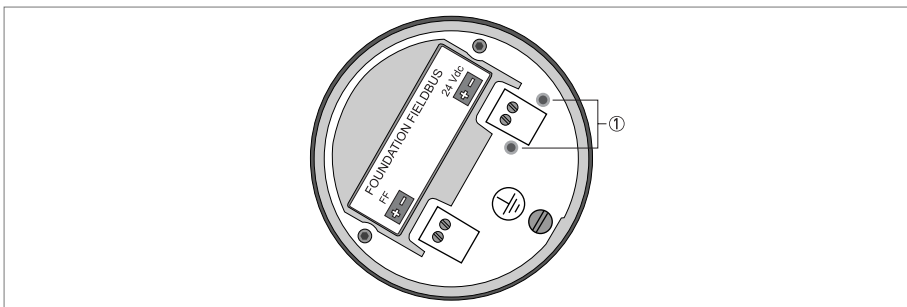

Figure 3-2: Electrical connection: PACTware™

① PACTware™ terminals

4.1 Description of device data

4.1.1 Resource block

The Resource Block supplies data about the device for operation in the FOUNDATION Fieldbus network. Its operation mode also has an effect on the data supplied by the device. The Resource Block has these operation modes:

- Automatic (Auto), and
- Out of Service (OOS)

In **Automatic** mode, all resources (including Transducer and Function blocks) can operate correctly.

In the **Out of Service** mode, all blocks are in Out of Service mode and no measurement and status data is supplied to the network. The blocks cannot change their mode until the Resource block is set again to Automatic mode. If a block is in Out of Service mode, this is shown in its BLOCK_ERR parameter.

4.1.2 Transducer block

The parameter MODE_BLK controls the mode set in the Transducer Block. The Transducer Block has these modes:

- Automatic (Auto),
- Manual (MAN), and
- Out of Service (OOS)

In **Automatic** mode, the Transducer operates correctly and supplies measurement values and status (PRIM_VAL_TYPE_0 to PRIM_VAL_TYPE_6).

The Transducer Block has a special error parameter **XD_ERROR**. If this parameter displays the error 'Electronics failure', it is possible that the device will not operate correctly. If the Transducer Block status does not change, please contact the local support desk of your supplier.

4.1.3 Measurement data

Use a master and the DD - CFF files to configure the device for the network. Set the measurement values (modules) that are regularly transmitted to the master device. The table that follows gives a list of measurement data (each value has a status) that is available in this sequence.

Measurement data

Foundation Fieldbus Variable	Measurement variable	Unit
PRIM_VAL_TYPE_0	Level	Meter
PRIM_VAL_TYPE_1	Distance	Meter
PRIM_VAL_TYPE_2	Level Conversion ①	Cubic meter
PRIM_VAL_TYPE_3	Level Mass ①	Ton (metric)
PRIM_VAL_TYPE_4	Reflection	%
PRIM_VAL_TYPE_5	Ullage Conversion ①	Cubic meter
PRIM_VAL_TYPE_6	Distance Mass ①	Ton (metric)

① if there is no conversion table, this measurement is not available. The message "Not_a Number (non signalling) is transmitted. The status is set to "Bad-Out of Service".

4.1.4 Status data



CAUTION!

Monitor the status of the device. The device transmits a measurement value when the device status is "good", "uncertain" or "bad". The status will tell you if the device measures correctly.









KROHNE product overview

- Electromagnetic flowmeters
- Variable area flowmeters
- Ultrasonic flowmeters
- Mass flowmeters
- Vortex flowmeters
- Flow controllers
- Level meters
- Temperature meters
- Pressure meters
- Analysis products
- Measuring systems for the oil and gas industry
- Measuring systems for sea-going tankers

Head Office KROHNE Messtechnik GmbH
Ludwig-Krohne-Str. 5
D-47058 Duisburg (Germany)
Tel.: +49 (0)203 301 0
Fax: +49 (0)203 301 10389
info@krohne.de

The current list of all KROHNE contacts and addresses can be found at:
www.krohne.com

KROHNE