

Supplementary Installation and Operating Instructions

HART Communicator 275
Field Communicator 375
Asset Management Solutions (AMS)
Process Device Manager (PDM)



UFC 030 Ultrasonic Flow Converter



1	General Information	3
2	IDs and Revision numbers	5
3	HART Communicator 275 (HC275), Field Communicator 375 (FC375)	6
3.1	Installation	6
3.2	Operating	6
4	Asset Management Solutions (AMS)	6
4.1	Installation	6
4.2	Operating	6
5	Process Device Manager (PDM)	7
5.1	Installation	7
5.2	Operating	7

1 General Information

The UFC 030 is a “four-wire” transmitter with 4...20mA current output and HART® capability. Dependent on device implementation it is available with active/passive current output (standard) or passive current output (MODIS).

General Characteristics of the UFC 030 HART® interface:

- Multidrop Mode is supported
- Burst Mode is not supported

Electrical connection: Refer to section “Electrical connection of the signal inputs and outputs” of the following manual:

- “Installation and Operating Instructions Universal 3-Beam ultrasonic flowmeter UFM 3030 Compact ultrasonic flowmeter UFC 030 Ultrasonic flow converter UFS 3000 Ultrasonic flow sensor” (KROHNE)

There are two ways of using the HART® communication:

- a) As a point-to-point connection between the UFC 030 and the HART® master equipment. The instrument's current output may be active or passive.

Point-to-Point Analog/Digital Mode

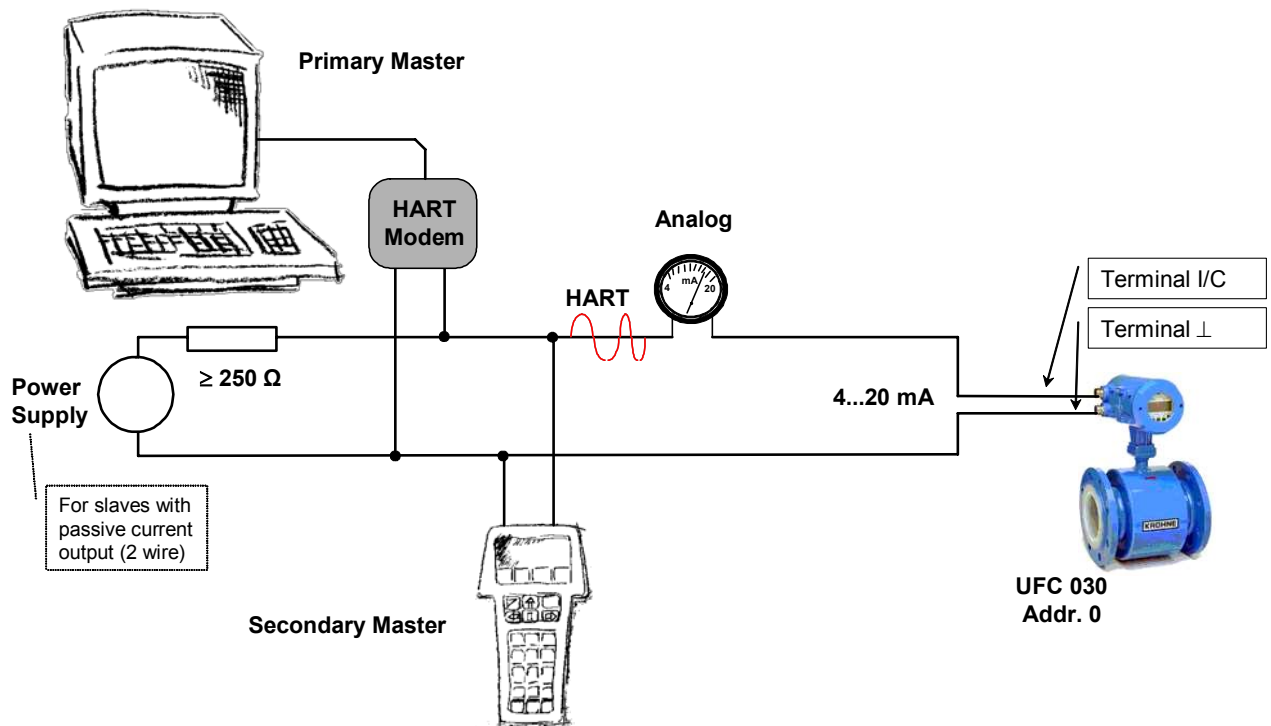

b) As a multipoint connection (multidrop) with up to 15 devices (UFC 030 or other HART® equipment) in parallel. The instrument's current outputs must be passive.

Multidrop Mode

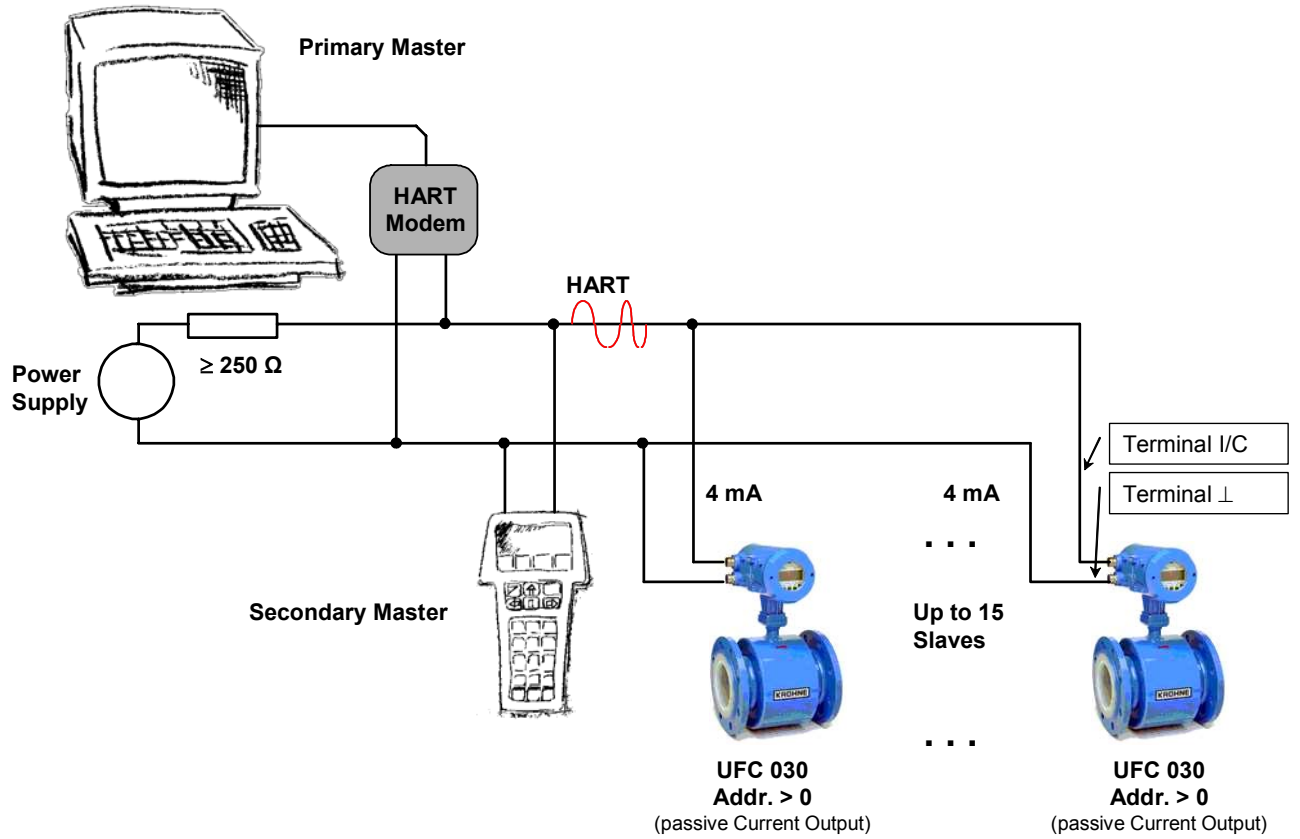

In case the UFC 030's current output shall work continuously active a 'third wire' is needed to properly connect it together with two-wire loop powered devices in the same network.

Multidrop Mode ('three-wire')

(Connecting two-wire and four-wire devices in the same network)

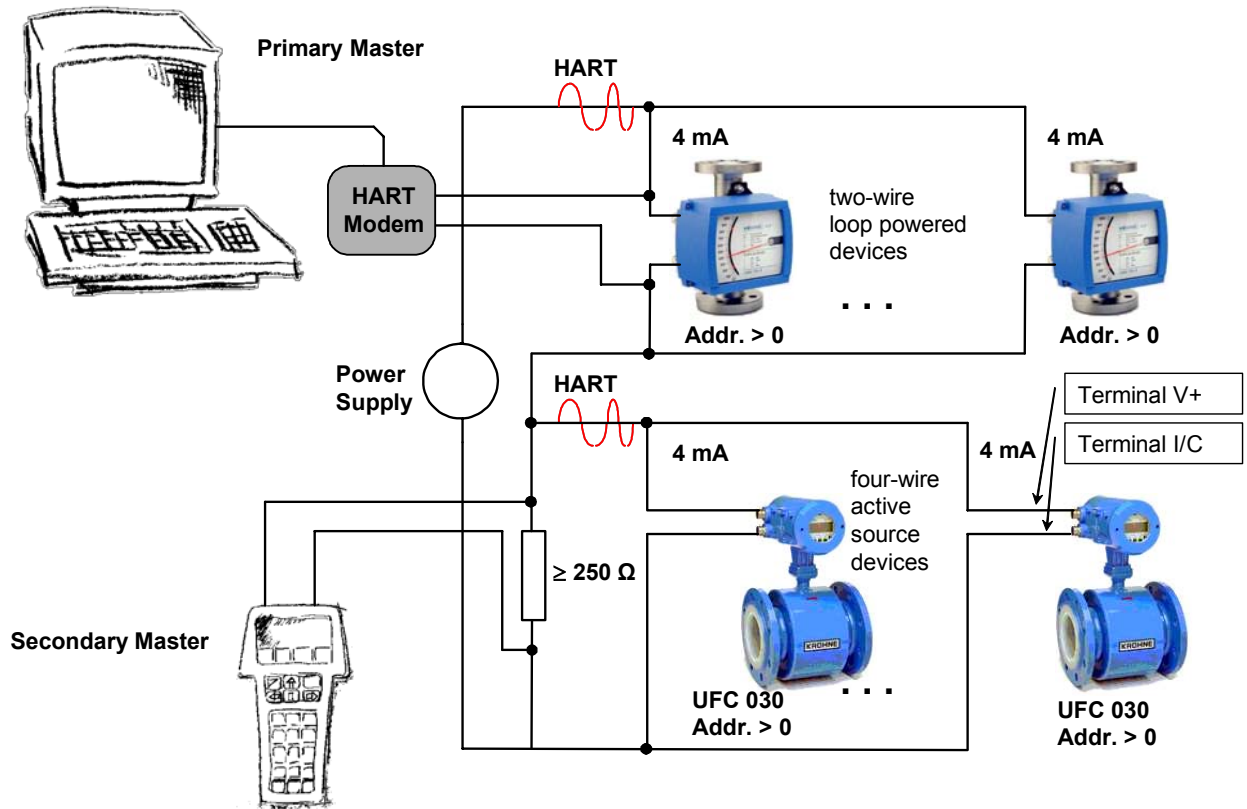

2 IDs and Revision numbers

The HART Device Descriptions described in this document have the following IDs and revision numbers:

Manufacturer ID:	69 (0x45)
Device Type:	231 (0xE7)
Device Revision:	2
DD Revision:	1
HART Universal Revision:	5
HC 275 OS Revision:	≥ 4.9
FC 375 System SW Rev.:	≥ 1.6
AMS Version:	≥ 6.0
PDM Version:	≥ 5.2
FDT Version:	≥ 1.2

For information about Transmitter Revisions and related Device Descriptions refer to the KROHNE HART Device List.

3 HART Communicator 275 (HC275), Field Communicator 375 (FC375)

3.1 Installation

The UFC 030 HART Device Description has to be installed on the HC275 and FC375 respectively. Otherwise the user will work with the instrument as a generic one thus losing opportunity for entire instrument control. For installing DDs on the HC275 a 'HART Communicator Module Programmer' is needed (see details in the 'Module Programmer User's Guide').

For installing DDs on the FC375 the 'Easy Upgrade Programming Utility' is needed and the FC375 must have a System Card with 'Easy Upgrade' option (see details in the '375 Field Communicator User's Manual').

3.2 Operating

Refer to the UFC 030 Menu Tree HC275 / FC375 (Attachment A).

The UFC 030 operation via HC275 / FC375 is made quite close to the manual instrument control via keypad.

Due to limitations of the HC275 / FC375 there are some peculiarities:

- The online help of each parameter is only a short form help. However it contains the function number as a reference to the device's local display and the "Installation and Operating Instructions" for a comprehensive description.
- Some selection lists (e.g. for output functions) may contain items which are actually not valid for the device concerned. However invalid settings are rejected when trying to send them to the device.

Parameter protection via passwords (Entry Code, Service Code) is the same as on local display. Please refer to the online help for valid symbols according to device's keypad.

The set of parameters of the HC275 "standard configuration" is only a partial set which doesn't contain service parameters. However the HC275 "full configuration" contains a complete set of parameters. Prior to sending a "full configuration" to a device the Service Code protection must be disabled in case. Both types of configurations can be transferred to AMS.

The FC375 always creates a "full" configuration for interaction with AMS. Still the FC375 considers only a partial parameter set (like the HC275 "standard configuration") when sending it to a device.

4 Asset Management Solutions (AMS)

4.1 Installation

If the UFC 030 Device Description is not already installed on the AMS System a so called *Installation Kit UFC 030 HART AMS* is needed (available as download from KROHNE 'Download Centre' on the internet or on floppy disk / CD-ROM from KROHNE).

For installing the DD with the Installation Kit refer to the "*AMS Intelligent Device Manager Books Online*" section "*Basic AMS Functionality / Device Configurations / Installing Device Types / Procedures / Install device types from media*". Please read also the "readme.txt", which is also contained in the Installation Kit.

4.2 Operating

Refer to the UFC 030 Menu Tree AMS (Attachment B).

Due to AMS requirements and conventions the UFC 030 operation differs to some extent from operation with HC275 / FC375 and via local keypad.

Due to limitations of the HC275 / FC375 which affect also AMS there are some peculiarities:

- The online help of each parameter is only a short form help. However it contains the function number as a reference to the device's local display and the "Installation and Operating Instructions" for a comprehensive description.
- Some selection lists (e.g. for output functions) may contain items which are actually not valid for the device concerned. However invalid settings are rejected when trying to send them to the device.

Parameter protection via passwords (Entry Code, Service Code) is the same as on local display. Please refer to the online help for valid symbols according to device's keypad.

5 Process Device Manager (PDM)

5.1 Installation

If the UFC 030 Device Description is not already installed on the PDM System a so called *Device Install* is needed (available as download from KROHNE 'Download Centre' on the internet or on floppy disk / CD-ROM from KROHNE).

For installing the DD with the Device Install refer to the "*PDM Manual*" section 11.2: "*Device Install / Integrating Devices in SIMATIC PDM with 'Device Install'*". Please read also the "readme.txt", which is also contained in the Device Install.

5.2 Operating

Refer to the UFC 030 Menu Tree PDM (Attachment C).

Due to PDM requirements and conventions the UFC 030 operation differs to some extent from operation with HC275 / FC375 and via local keypad.

Due to limitations of the HC275 / FC375 which affect also PDM there are some peculiarities:

- The online help of each parameter is only a short form help. However it contains the function number as a reference to the device's local display and the "Installation and Operating Instructions" for a comprehensive description.
- Some selection lists (e.g. for output functions) may contain items which are actually not valid for the device concerned. However invalid settings are rejected when trying to send them to the device.

Parameter protection via passwords (Entry Code, Service Code) is the same as on local display. Please refer to the online help for valid symbols according to device's keypad.

Attachment A

UFC 030 HART Menu Tree HC275 / FC375

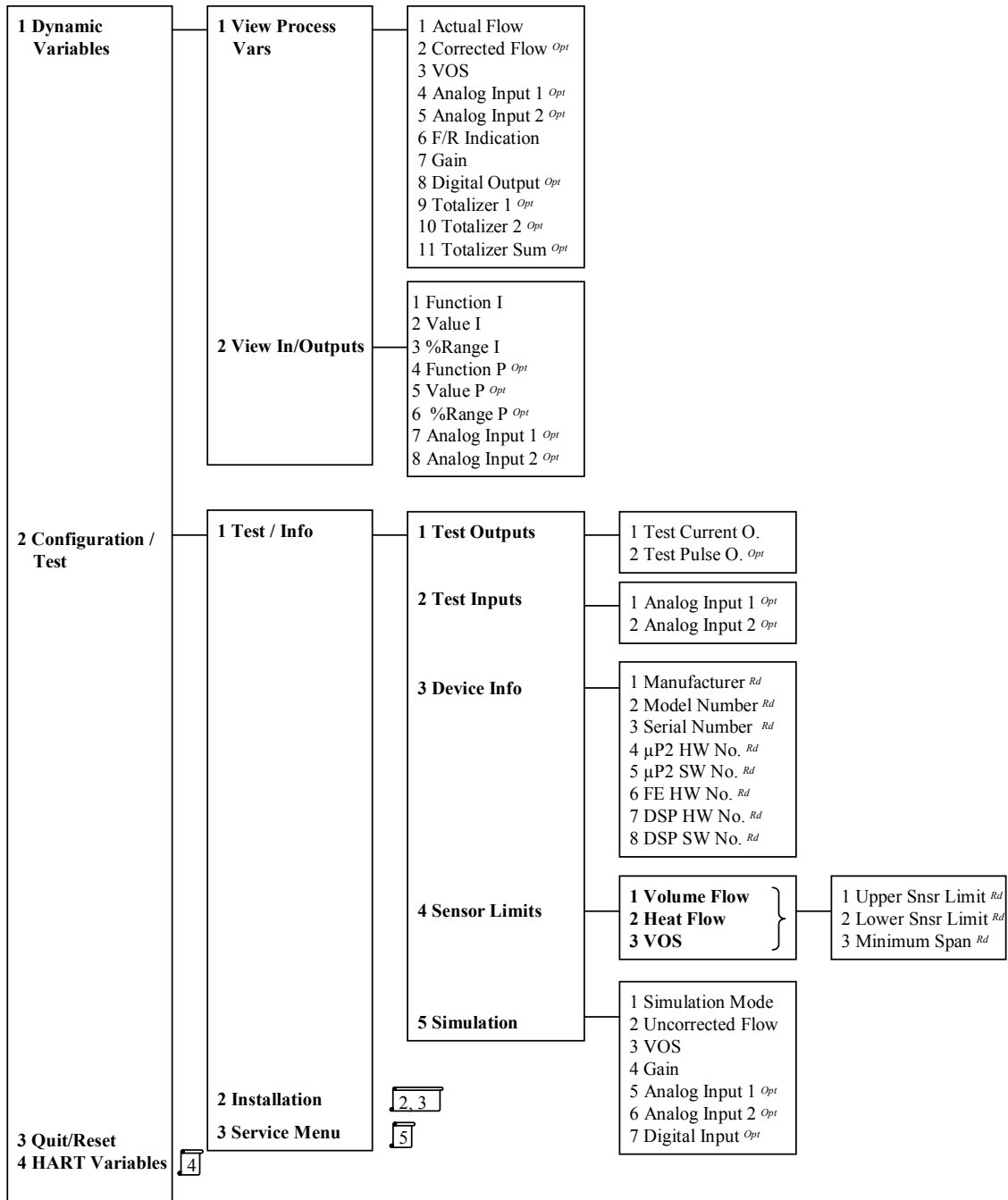

Designations:

Opt Optional, dependent on device implementation / configuration

Rd Read-only

Loc Local HC275/FC375, affects only HC275/FC375 views

KROHNE UFC030 HA 45e70201 (1/5)
05/04

UFC 030 HART Menu Tree HC275 / FC375

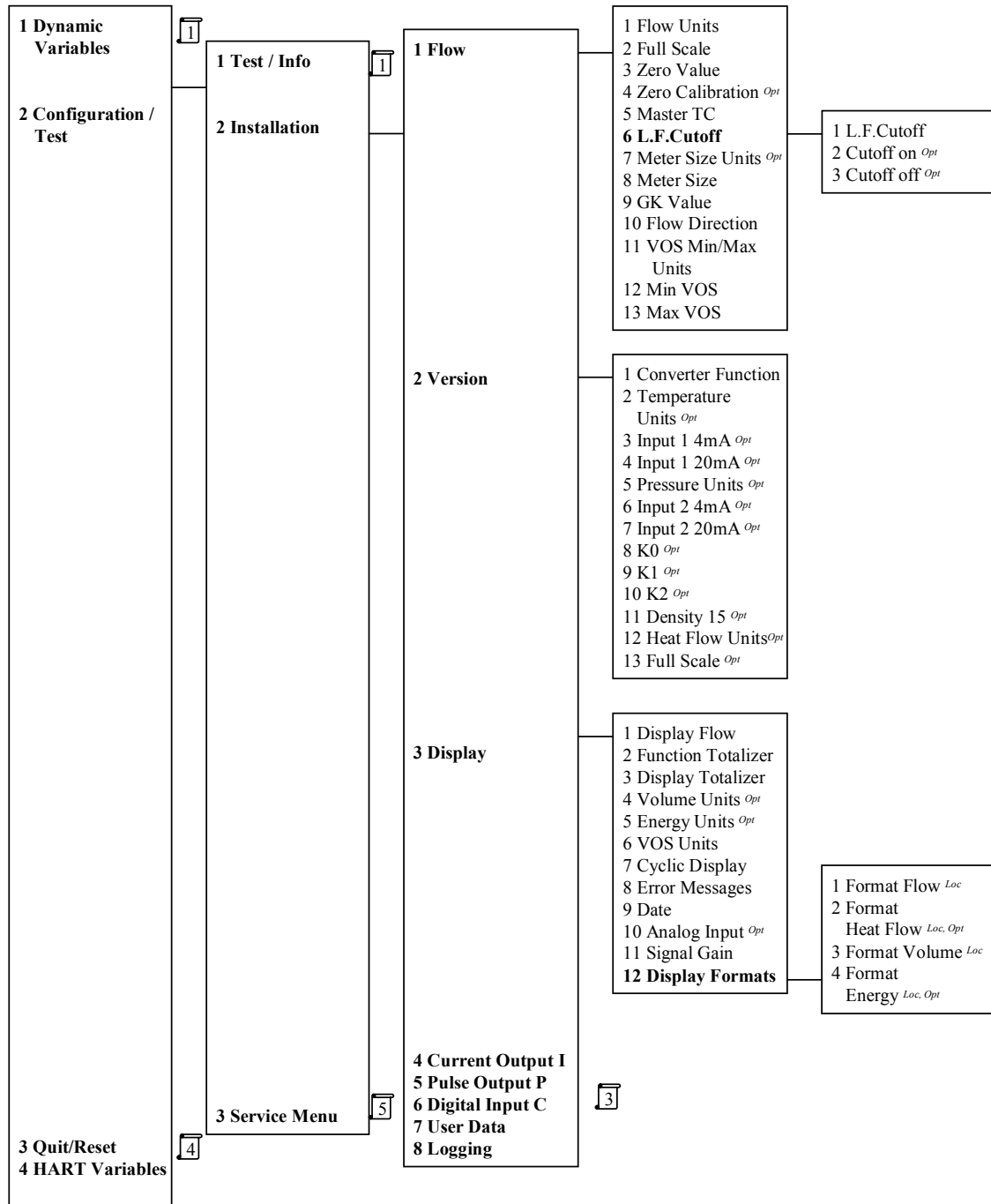

Designations:

Opt Optional, dependent on device implementation / configuration

Rd Read-only

Loc Local HC275/FC375, affects only HC275/FC375 views

KROHNE UFC030 HA 45e70201 (2/5)
 05/04

UFC 030 HART Menu Tree HC275 / FC375

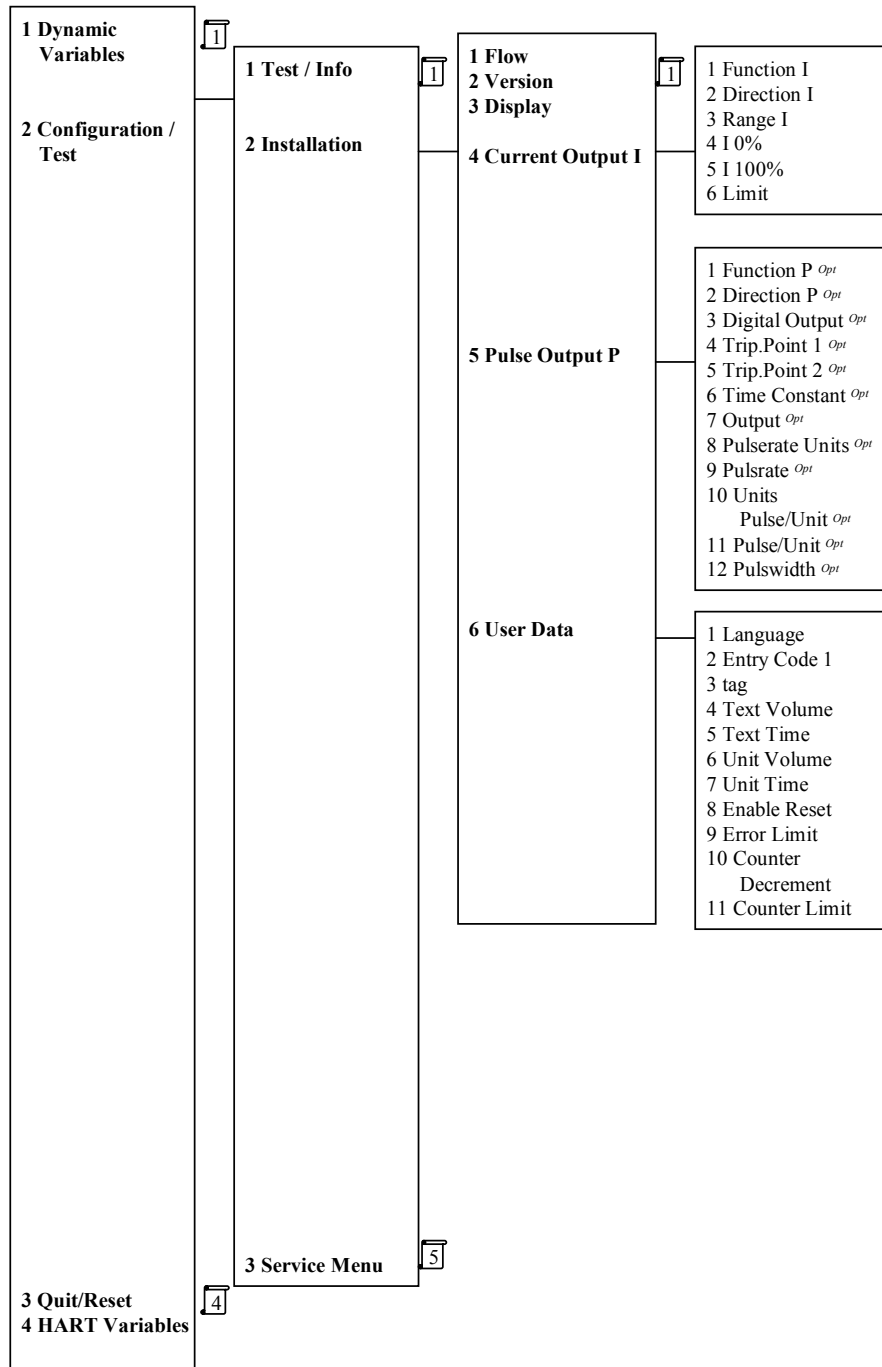

Designations:

Opt Optional, dependent on device implementation / configuration

Rd Read-only

Loc Local HC275/FC375, affects only HC275/FC375 views

KROHNE UFC030 HA 45e70201 (3/5)
 05/04

UFC 030 HART Menu Tree HC275 / FC375

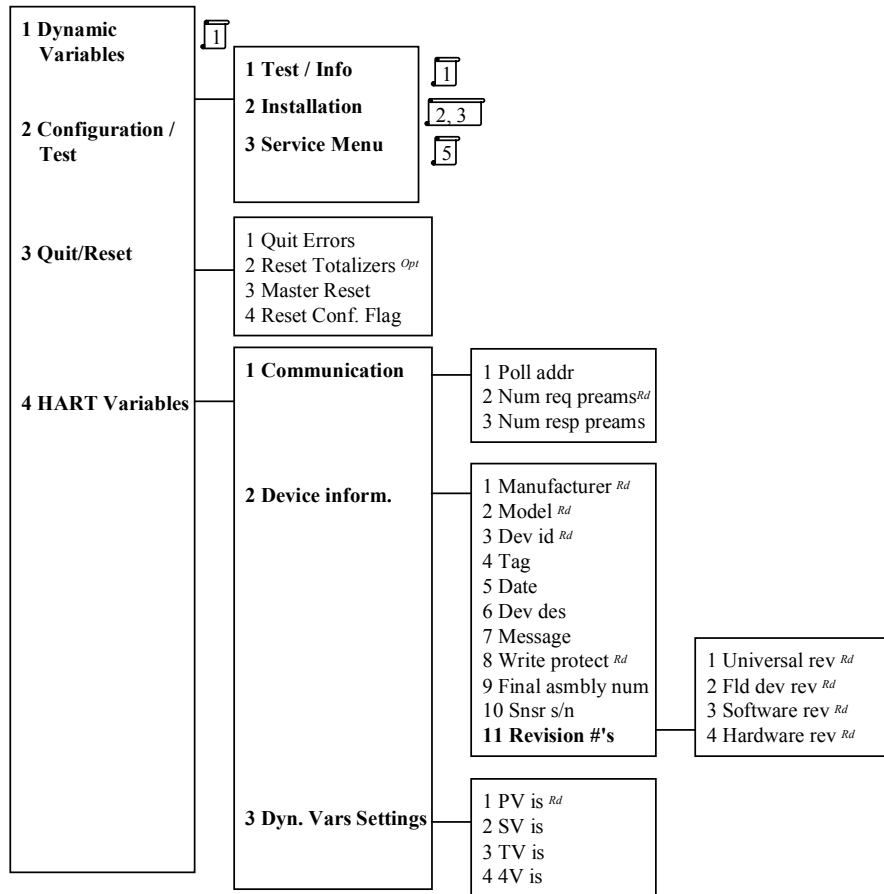

Designations:

Opt Optional, dependent on device implementation / configuration

Rd Read-only

Loc Local HC275/FC375, affects only HC275/FC375 views

KROHNE UFC030 HA 45e70201 (4/5)
05/04

UFC 030 HART Menu Tree HC275 / FC375

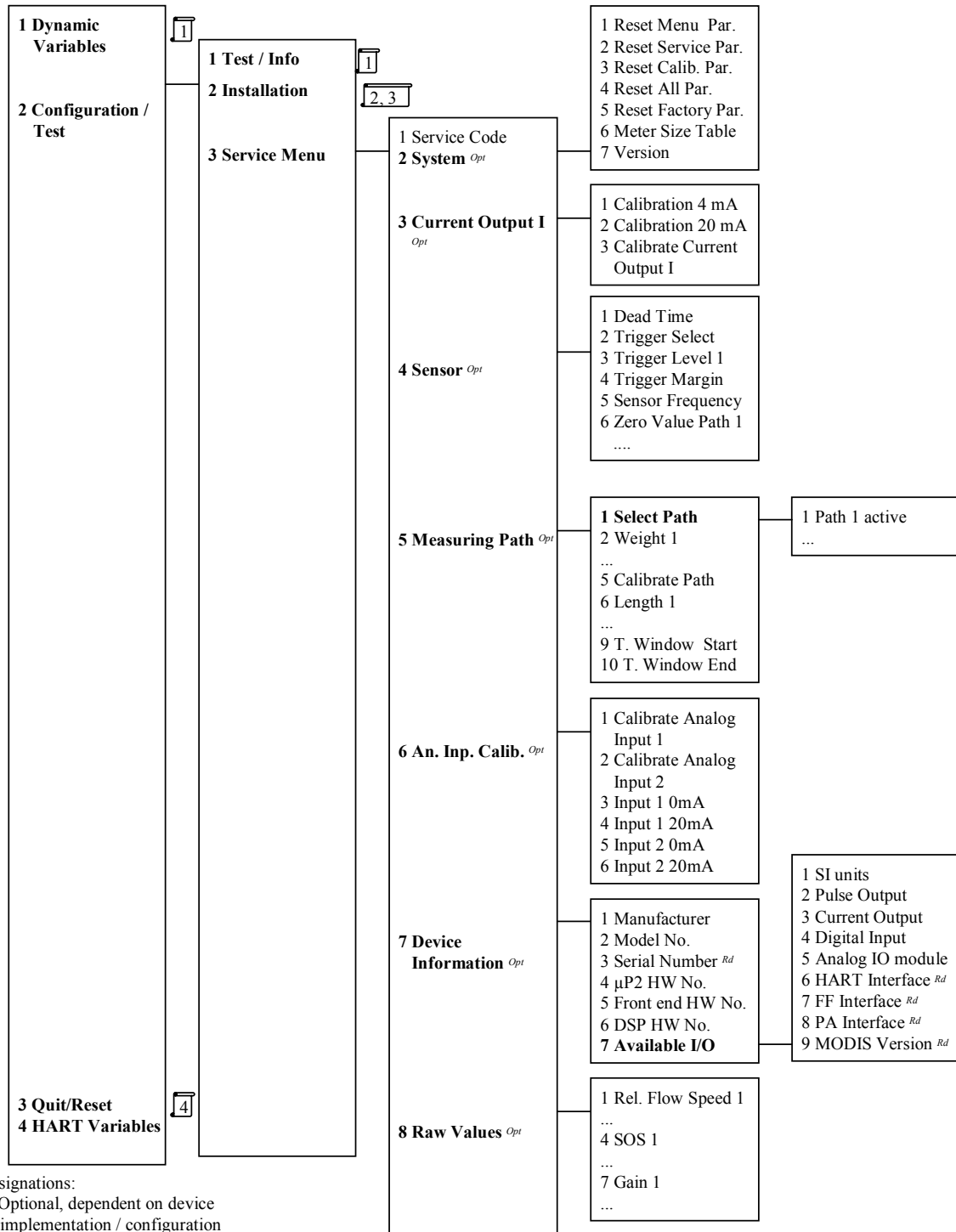

Designations:
Opt Optional, dependent on device implementation / configuration
Rd Read-only
Loc Local HC275/FC375, affects only HC275/FC375 views

KROHNE UFC030 HA 45e70201 (5/5)
05/04

UFC 030 HART Menu Tree AMS

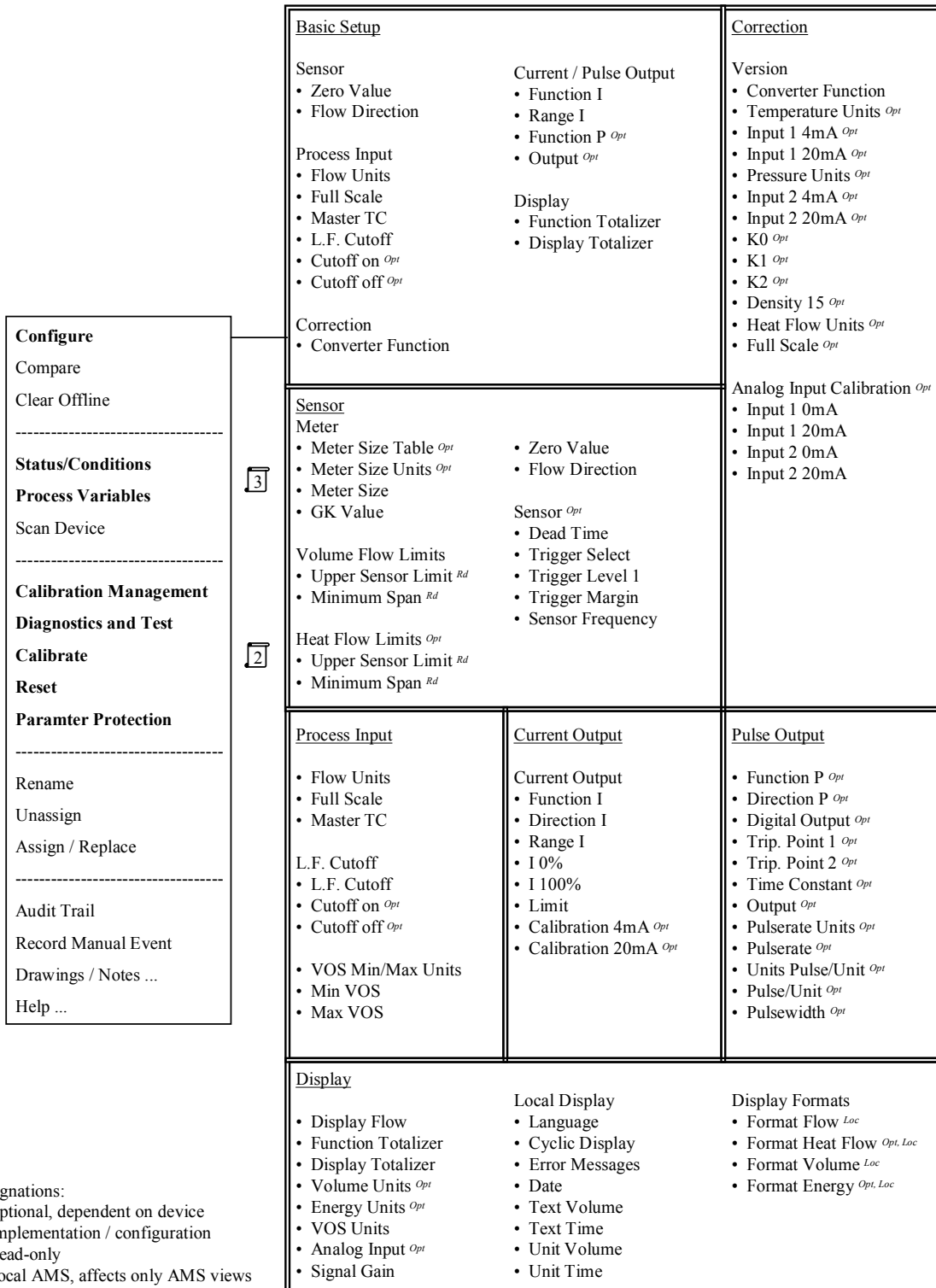

Designations:
Opt Optional, dependent on device implementation / configuration
Rd Read-only
Loc Local AMS, affects only AMS views

KROHNE UFC 030 HA 45e70201 (1/3)
09/04

UFC 030 HART Menu Tree AMS

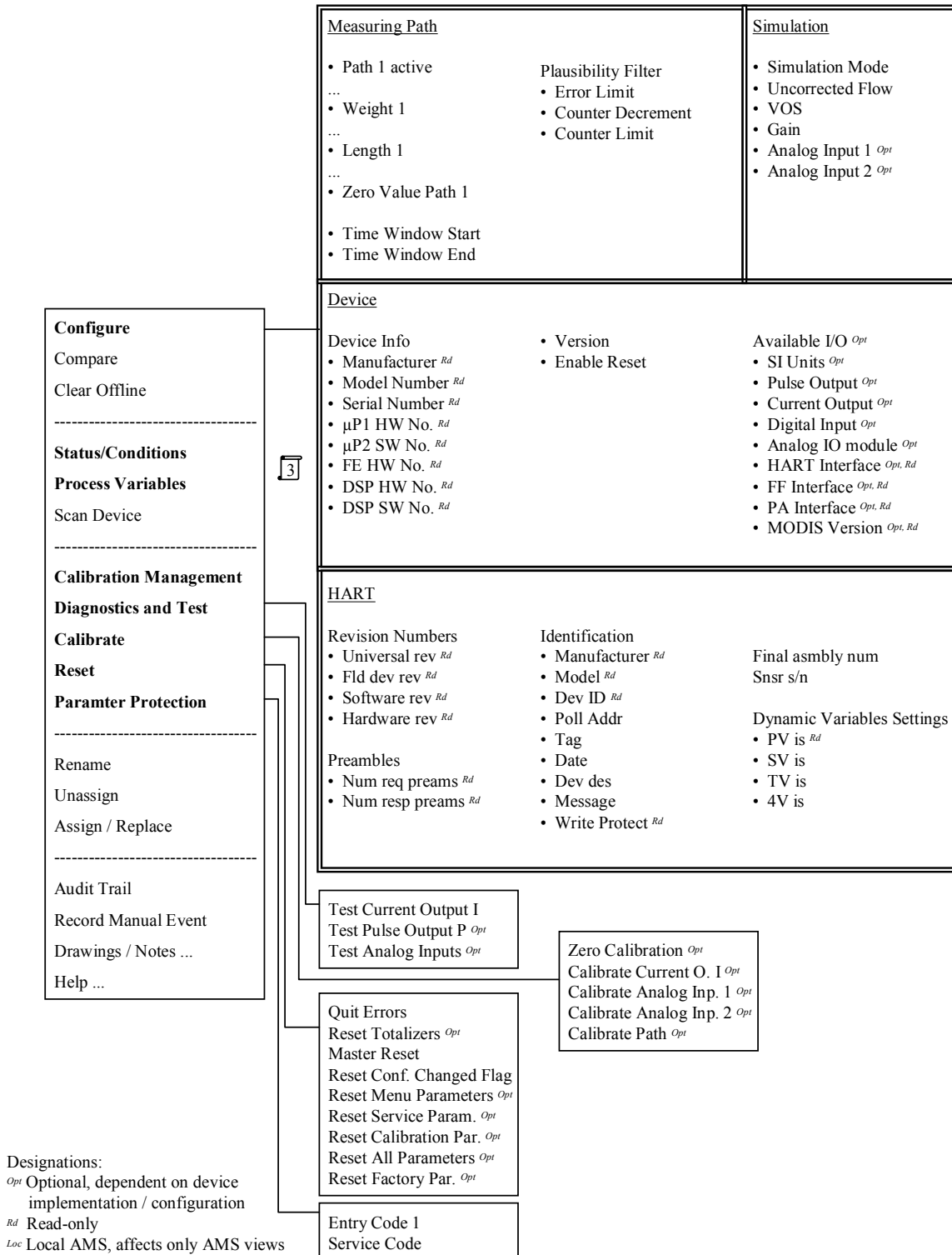

KROHNE UFC 030 HA 45e70201 (2/3)
09/04

UFC 030 HART Menu Tree AMS

1

Configure
Compare
Clear Offline

Status/Conditions
Process Variables
Scan Device

Calibration Management
Diagnostics and Test
2
Calibrate
Reset
Parameter Protection

Rename
Unassign
Assign / Replace

Audit Trail
Record Manual Event
Drawings / Notes ...
Help ...

Overview <ul style="list-style-type: none"> Primary variable out of limits Non-primary variable out of limits Primary variable analog output saturated Primary variable analog output fixed Cold start Configuration changed Field device malfunction 		Sensor / Device <ul style="list-style-type: none"> Path 1 Signal Failure ... Path 3 Signal Failure Sensor open Sensor short circuit Unreliable Empty Pipe Error Signal Proc. Contr. Error Peripheral Contr. Error HW error frontend Communication error EEPROM R/W Error Checks. err. service par. Checks. err. menu par. Simulation mode active Restart 	
IO / Totalizers <ul style="list-style-type: none"> Underrun analog input 1 Overrun analog input 1 Underrun analog input 2 Overrun analog input 2 20mA Analog Input HW Error Calibration Data Lost Current Output Overrange Current Output in fixed mode Pulse Output Overrange Pulse Output in fixed mode Totalizer Overrun Error Totalizer Storage Error PRimary flow Overrun Error SECOndary flow Overrun Error 		Raw Values <ul style="list-style-type: none"> Relative Flow Speed 1 ... 3 <i>Opt</i> SOS 1 ... 3 <i>Opt</i> Gain 1 ... 3 <i>Opt</i> 	
Process Values <ul style="list-style-type: none"> Actual Flow Corrected Flow <i>Opt</i> VOS 		Totalizers <ul style="list-style-type: none"> Totalizer 1 <i>Opt</i> Totalizer 2 <i>Opt</i> Totalizer Sum <i>Opt</i> 	
Correction <ul style="list-style-type: none"> Analog Input 1 <i>Opt</i> Analog Input 2 <i>Opt</i> 		Current Output <ul style="list-style-type: none"> Value Percent of Range 	
Additional Values <ul style="list-style-type: none"> F/R Indication Gain 		Pulse Output P <ul style="list-style-type: none"> Value <i>Opt</i> Percent of Range <i>Opt</i> 	
Device <ul style="list-style-type: none"> Tag Descriptor <i>Opt</i> 		HART <ul style="list-style-type: none"> Polling Address Device ID 	

Designations:

Opt Optional, dependent on device implementation / configuration

Rd Read-only

Loc Local AMS, affects only AMS views

KROHNE UFC 030 HA 45e70201 (3/3)
09/04

**UFC 030 HART Menu Tree PDM
Menu Bar**

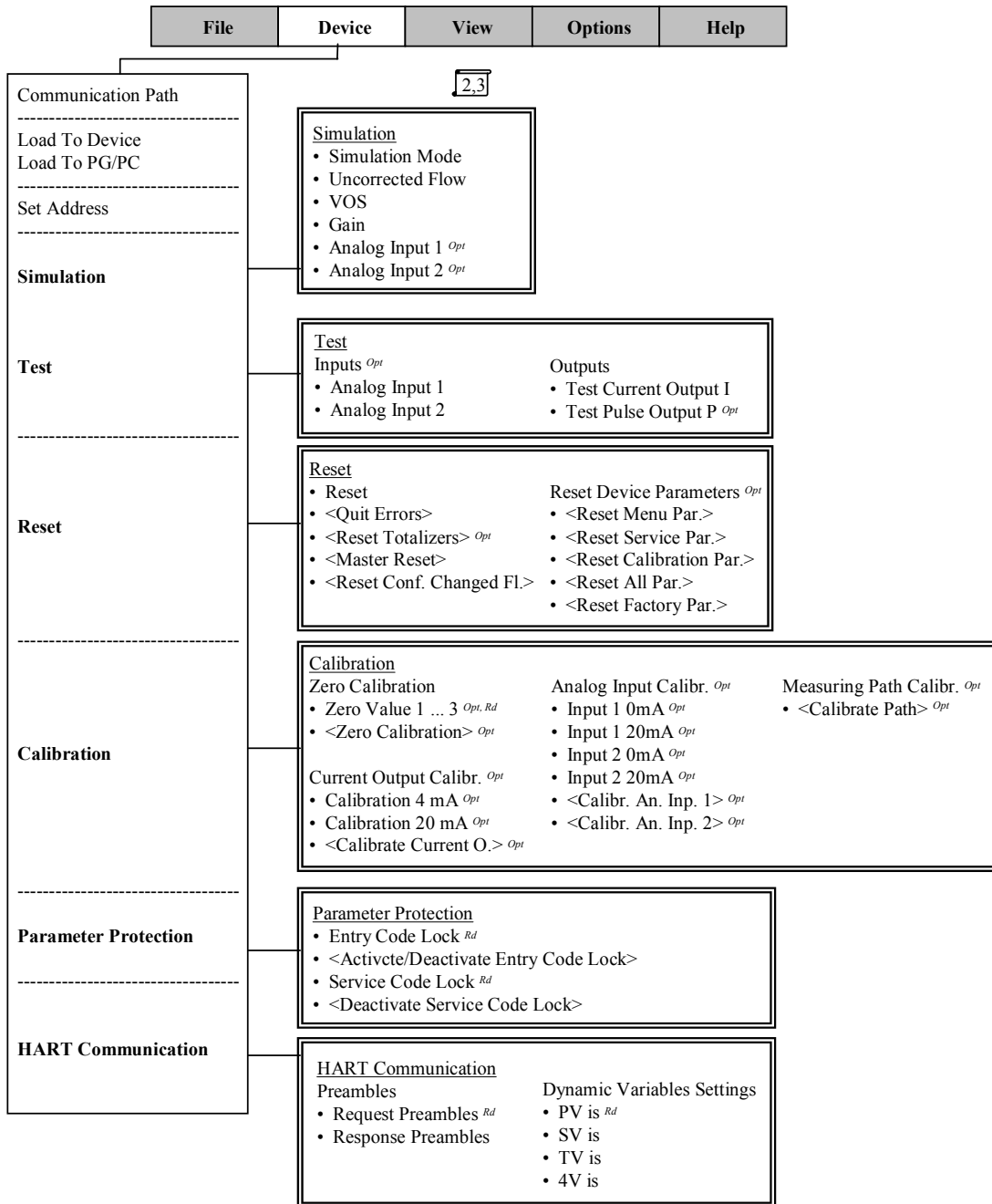

Designations:

Opt Optional, dependent on device implementation / configuration

Rd Read-only

Loc Local PDM, affects only PDM views

**UFC 030 HART Menu Tree PDM
Menu Bar**

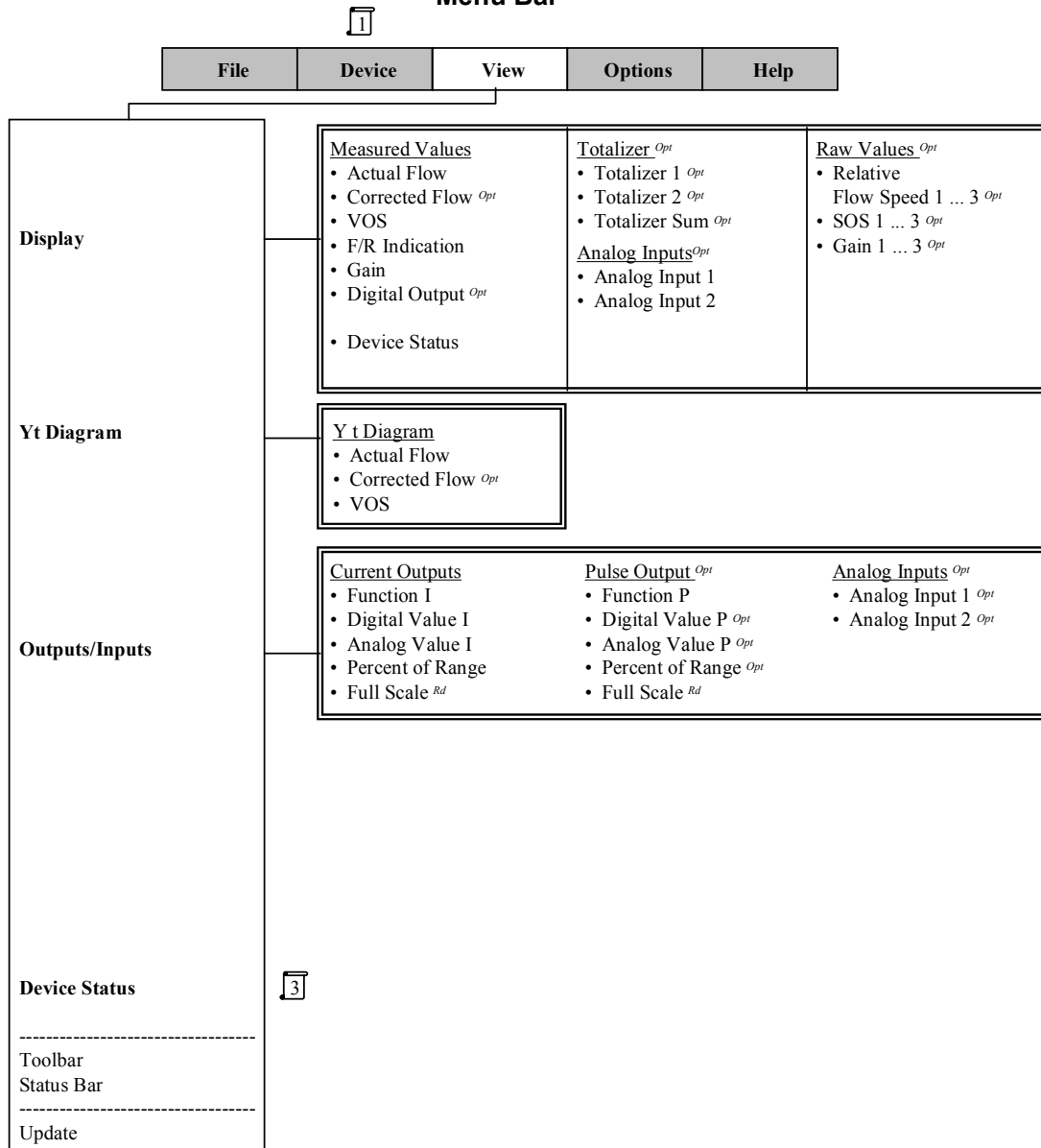

Designations:

^{Opt} Optional, dependent on device implementation / configuration

Rd Read-only

^{Loc} Local PDM, affects only PDM views

KROHNE UFC030 HA 45e80101 (2/5)
09.04

**UFC 030 HART Menu Tree PDM
Menu Bar**

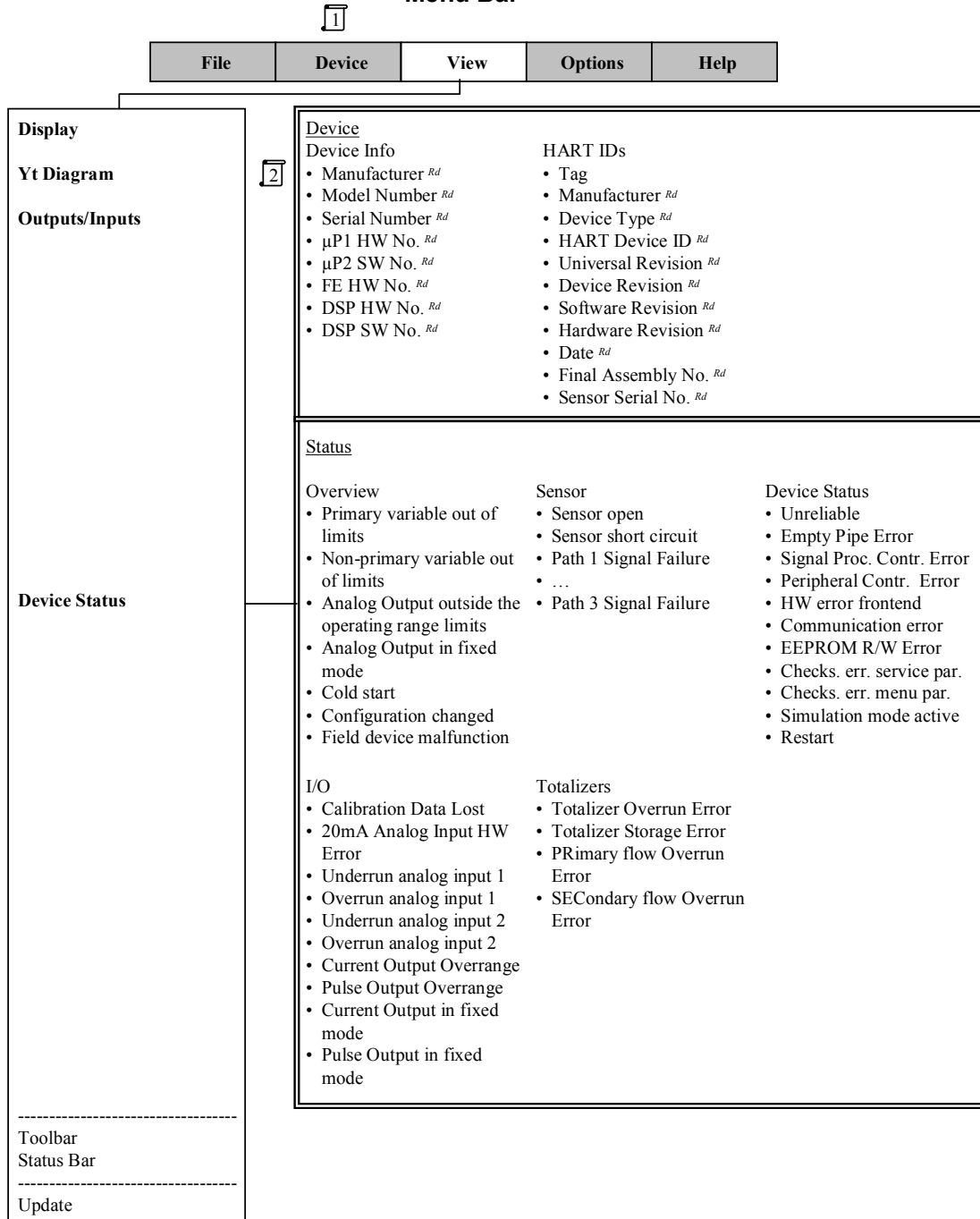

Designations:

Opt Optional, dependent on device implementation / configuration

Rd Read-only

Loc Local PDM, affects only PDM views

KROHNE UFC030 HA 45e80101 (3/5)
09.04

**UFC 030 HART Menu Tree PDM
Parameter Table**

<p>Identification</p> <p>Operation Unit</p> <p>Device</p> <p>-----</p> <p>Input</p> <p>Measuring Limits</p> <p>Operation Parameter</p> <p>Sensor</p> <p>Version</p> <p>Analog Input ^{Opt}</p> <p>Measuring Path ^{Opt}</p> <p>Plausibility Filter</p> <p>-----</p> <p>Output</p> <p>Current Output I</p> <p>Pulse Output P ^{Opt}</p> <p>-----</p> <p>Human Interface</p> <p>Local Display</p> <p>Display Formats</p>	<p>5</p> <p>5</p>	<p><u>Identification</u></p> <p><u>Operation Unit</u></p> <ul style="list-style-type: none"> • Tag • Descriptor • Message <p><u>Device</u></p> <ul style="list-style-type: none"> • Manufacturer Rd • Model Number Rd • Serial Number Rd • µP1 HW No. Rd • µP2 SW No. Rd • FE HW No. Rd • DSP HW No. Rd • DSP SW No. Rd • Version Rd • Meter Size Table ^{Opt} • Enable reset <p>Available I/O ^{Opt}</p> <ul style="list-style-type: none"> • SI Units • Pulse Output • Current Output • Digital Input • Analog IO module • HART Interface Rd • FF Interface Rd • PA Interface Rd • MODIS Version Rd • Time/log Module Rd <p>HART</p> <ul style="list-style-type: none"> • Manufacturer Rd • Device Type Rd • HART Device ID Rd • Universal Revision Rd • Field Device Revision Rd • Software Revision Rd • Hardware Revision Rd • Date • Final Assembly No. • Sensor Serial No. <p><u>Input</u></p> <ul style="list-style-type: none"> • Flow Units • Full Scale • Zero Value • Master TC • GK Value • Flow Direction • VOS Min/Max Units • Min VOS • Max VOS • L.F. Cutoff • Cutoff on ^{Opt} • Cutoff off ^{Opt} 	<p><u>Input</u></p> <p>...</p> <p><u>Process Connection</u></p> <ul style="list-style-type: none"> • Meter Size Table ^{Opt} • Meter Size Units ^{Opt} • Meter Size <p><u>Measuring Limits</u></p> <p><u>Volume Flow</u></p> <ul style="list-style-type: none"> • Upper Sensor Limit Rd • Minimum Span Rd <p><u>Heat Flow</u></p> <ul style="list-style-type: none"> • Upper Sensor Limit Rd • Minimum Span Rd <p><u>VOS</u></p> <ul style="list-style-type: none"> • Upper Sensor Limit Rd • Lower Sensor Limit Rd • Minimum Span Rd <p><u>Operation Parameter</u></p> <p><u>Sensor ^{Opt}</u></p> <ul style="list-style-type: none"> • Dead Time • Trigger Select • Trigger Level 1 • Trigger Margin • Sensor Frequency <p><u>Version ^{Opt}</u></p> <ul style="list-style-type: none"> • Converter Function • Temperature Units ^{Opt} • Input 1 4mA ^{Opt} • Input 1 20mA ^{Opt} • Pressure Units ^{Opt} • Input 2 4mA ^{Opt} • Input 2 20mA ^{Opt} • K0 ^{Opt} • K1 ^{Opt} • K2 ^{Opt} • Density 15 ^{Opt} • Heat Flow Units ^{Opt} • Full Scale ^{Opt} <p><u>Analog Input Calibration ^{Opt}</u></p> <ul style="list-style-type: none"> • Input 1 0mA • Input 1 20mA • Input 2 0mA ^{Opt} • Input 2 20mA ^{Opt} <p><u>Measuring Path ^{Opt}</u></p> <ul style="list-style-type: none"> • Path 1 active ... • Weight 1 ... • Length 1 ... • Zero Value 1 ... • Time Window Start • Time Window End <p><u>Plausibility Filter</u></p> <ul style="list-style-type: none"> • Error Limit • Counter Decrement • Counter Limit
---	-------------------	---	--

Designations:
^{Opt} Optional, dependent on device implementation / configuration
Rd Read-only
^{Loc} Local PDM, affects only PDM views

KROHNE UFC030 HA 45e80101 (4/5)
09.04

**UFC 030 HART Menu Tree PDM
Parameter Table**

<p>Identification</p> <p>Operation Unit</p> <p>Device</p> <hr/> <p>Input</p> <p>Measuring Limits</p> <p>Operation Parameter</p> <p>Sensor</p> <p>Version</p> <p>Analog Input <i>Opt</i></p> <p>Measuring Path <i>Opt</i></p> <p>Plausibility Filter</p> <hr/> <p>Output</p> <p>Current Output I</p> <p>Pulse Output P <i>Opt</i></p> <hr/> <p>Human Interface</p> <p>Local Display</p> <p>Display Formats</p>	<p>Output</p> <ul style="list-style-type: none"> • IO Fitted <i>Rd</i> <p><u>Current Output I</u></p> <ul style="list-style-type: none"> • Function I • Direction I • Range I • I 0% • I 100% • Limit • Calibration 4mA <i>Opt</i> • Calibration 20mA <i>Opt</i> <p><u>Pulse Output P <i>Opt</i></u></p> <ul style="list-style-type: none"> • Function P • Direction P • Digital Output <i>Opt</i> • Trip. Point 1 <i>Opt</i> • Trip. Point 2 <i>Opt</i> • Time Constant • Output <i>Opt</i> • Pulsrate Units <i>Opt</i> • Pulserate <i>Opt</i> • Units Pulse/Unit <i>Opt</i> • Pulse/Unit <i>Opt</i> • Pulsewidth <i>Opt</i> <hr/> <p><u>Human Interface</u></p> <ul style="list-style-type: none"> • Display Flow • Function Totalizer • Display Totalizer <i>Opt</i> • Volume Units <i>Opt</i> • Energy Units <i>Opt</i> • VOS Units • Analog Input <i>Opt</i> • Signal Gain <p>Local Display</p> <ul style="list-style-type: none"> • Language • Cyclic Display • Error Messages • Date <i>Opt</i> • Text Volume • Text Time • Unit Volume • Unit Time <p>Display Formats</p> <ul style="list-style-type: none"> • Format Flow <i>Loc</i> • Format Heat Flow <i>Opt, Loc</i> • Format Volume <i>Loc</i> • Format Energy <i>Opt, Loc</i>
---	---

Designations:

Opt Optional, dependent on device implementation / configuration

Rd Read-only

Loc Local PDM, affects only PDM views

KROHNE UFC030 HA 45e80101 (5/5)
09.04