



VA FLOWMETERS Supplementary Instructions

Variable area flowmeters
without electrical built-ins

Type series DK32, DK34, DK37 M8M, DK37 M8MR, H250 M8MG, H250 M8MGR,
H250 M40, H250 M40R, DK46, DK47, DK48, DK800, GA24, VA40

Equipment category II 2 G, II 2 D



1	Safety instructions	3
<hr/>		
1.1	General notes	3
1.2	EU conformity	3
1.3	UK conformity	3
1.4	Safety instructions	4
2	Device description	5
<hr/>		
2.1	Device description	5
2.2	Designation code	5
2.3	Marking	8
2.4	Flammable products	11
2.5	Equipment category	12
2.6	Types of protection	12
2.7	Ambient temperature / Product temperature	13
2.8	Surface temperature	15
2.9	Ignition hazard assessment / protective measures	16
3	Installation	17
<hr/>		
3.1	Mounting	17
3.2	Special conditions	17
3.3	Grounding and equipotential bonding	18
4	Operation	21
<hr/>		
4.1	Start-up	21
4.2	Operation	21
4.3	Static electricity	21
4.3.1	Electrostatic charge caused by ambient conditions	21
4.3.2	Charging non-conductive external parts by cleaning	22
4.3.3	Process dependent charging	22
5	Service	23
<hr/>		
5.1	Dismantling	23
5.2	Maintenance	23
6	Notes	25
<hr/>		

1.1 General notes

These additional instructions apply to explosion-protected versions of variable area flowmeters with protection type "design safety c", category II 2 G, category II 2 D. They complete the standard documentation for the non explosion-protected versions.

The information given in these instructions contains only the data relevant to explosion protection.

The technical details given in the manual for the non explosion-protected versions remain unchanged unless they will be excluded or replaced by this supplementary instruction.

1.2 EU conformity

The manufacturer declares with the EU declaration of conformity on his own responsibility conformity with the requirements of directive 2014/34/EU for use in hazardous areas with gas and dust.

Conformity with the regulations was checked by the manufacturer in accordance with ISO 80079-36:2016 und ISO 80079-37:2016.

Third party certification is not required in accordance with the conformity assessment procedure for non-electrical equipment group II according item 13, section 1b (ii) of the directive 2014/34/EU (ATEX).

The technical documentation has been stored at the Physikalisch- Technische Bundesanstalt (PTB), Braunschweig, Germany under the registration number:

PTB 03 ATEX D127 X

The "X" after the registration number refers to special conditions for safe use of the device, which have been listed in these instructions.

1.3 UK conformity

The manufacturer declares with the UK declaration of conformity on his own responsibility conformity with the requirements of UKSI 2016:1107 (as amended by UKSI 2019:696 – Schedule 3A, Part 6) for use in hazardous areas with gas and dust.

Conformity with the regulations was checked by the manufacturer in accordance with ISO 80079-36:2016 und ISO 80079-37:2016.

Third party certification is not required in accordance with the conformity assessment procedure for non-electrical equipment group II according amendment to regulation 39.

1.4 Safety instructions

If these instructions are not followed, there is a risk of explosion.

Assembly, installation, start-up and maintenance may only be performed by **personnel trained in explosion protection!**



CAUTION!

The operator or his agent is responsible for observing any additional standards, directives or laws if required due to operating conditions or place of installation.

This applies in particular to the use of easily detachable process connections when measuring flammable media.

2.1 Device description

Variable area flowmeters measure and display the flow of flammable and non-flammable gases and liquids.

2.2 Designation code

The safety designation code consists of the following elements *:

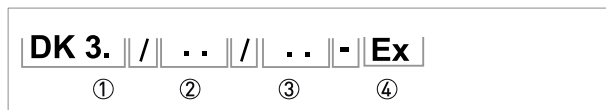

Figure 2-1: Safety designation code for the type series of DK32 / DK34

- ① **Type series of measuring unit DK**
32 - with valve and horizontal connection
34 - without valve and vertical connection
- ② **Optional flow regulator**
RE - for variable inlet pressure
RA - for variable outlet pressure
- ③ **High-temperature version**
HT - high-temperature version
- ④ **Version**
Ex - explosion-protected equipment

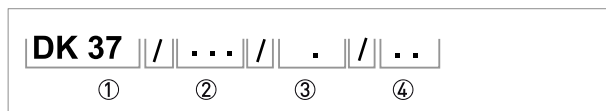

Figure 2-2: Safety designation code for the type series of DK37/M8M

- ① **Type series of DK37, optional with needle valve**
- ② **Type series of M8M, mechanical indicator**
- ③ **Design of indicator housing**
without - indicator housing in PPS
R - indicator housing in stainless steel
- ④ **Optional flow regulator**
RE - for variable inlet pressure
RA - for variable outlet pressure

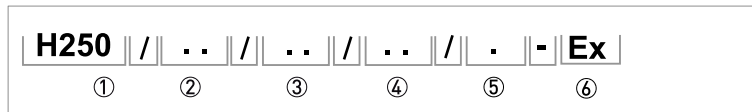

Figure 2-3: Safety designation code for the type series of H250/M8MG

- ① **Type series of measuring unit H250**
- ② **Materials / versions**
 - RR - stainless steel
 - C - PTFE or PTFE with ceramic liner
 - HC - Hastelloy®
 - Ti - Titanium
 - MO - Monel
 - IN - Inconel
 - F - Food
- ③ **Type series of indicators - M8**
- ④ **Design of indicator M8**
 - MG - mechanical indicator
- ⑤ **Design of indicator housing**
 - without - indicator housing in PPS
 - R - indicator housing in stainless steel
- ⑥ **Version**
 - Ex - explosion-protected version



Figure 2-4: Safety description code for the type series of H250 M40

- ① **Type series of measuring unit H250**
 - H250 - standard version, vertical upwards
 - H250H - horizontal orientation
 - H250U - vertical downwards
- ② **Measuring unit materials / versions**
 - RR - stainless steel
 - C - PTFE or PTFE/ceramics
 - HC - Hastelloy® C
 - Ti - Titanium
 - MO - Monel
 - IN - Inconel
 - F - Food
- ③ **Heating jacket version**
 - blank - without heating jacket
 - B - with heating jacket
- ④ **Signal converter version**
 - M40 - aluminium housing, painted (standard)
 - M40R - stainless steel housing
- ⑤ **High-temperature version**
 - blank - without HT extension
 - HT - with HT extension
- ⑥ **Version**
 - Ex - explosion-protected version

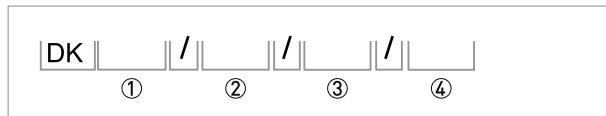

Figure 2-5: Safety designation code for the type series of DK glass

- ① R - with integrated inlet pressure regulator (DKR46 only)
- ② **Device type**
 - 46 - Overall length of measuring cone 65 mm / 2.6"
 - 47 - Overall length of measuring cone 150 mm / 5.9"
 - 48 - Overall length of measuring cone 300 mm / 11.8"
 - 800 - Overall length of measuring cone 100 mm / 3.9"
- ③ **Material for top and bottom fittings**
 - N - brass
 - R - stainless steel
 - PV - PVDF
- ④ **Flow regulator**
 - RE - flow regulator for variable inlet pressure
 - RA - flow regulator for variable outlet pressure

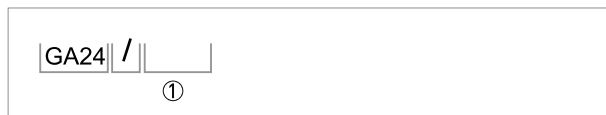

Figure 2-6: Safety designation code GA24

- ① **Material of connection**
 - R - stainless steel
 - PTFE - stainless steel with PTFE



Figure 2-7: Safety designation code VA40

- ① **Connection type**
 - V - screw connection
 - S - tube socket
 - F - flange connection
 - A - aseptic connection, conforming to food standards
- ② **Material of connection**
 - R - stainless steel 1.4404 (316 L)
 - ST - steel, electroplated and chromised
 - PV - plastic PVDF

* positions which are not needed are omitted (no blank positions)

2.3 Marking

The flowmeters are identified by the following nameplates (examples are not to scale):

Nameplate DK32, DK34, DK32 .. HT, DK34 .. HT



Figure 2-8: Example of a nameplate for DK32 HT (ATEX)

Nameplate DK32, DK34, DK32 .. HT, DK34 .. HT

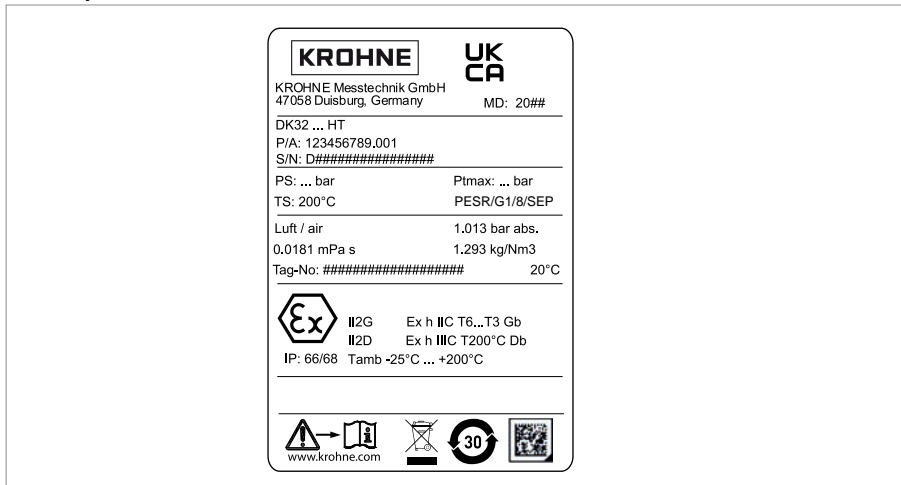

Figure 2-9: Example of a nameplate for DK32 HT (UKCA)

Nameplate H250/M40, DK37/M8M, DK37/M8M/R, H250/M8MG, H250/M8MG/R



Figure 2-10: Example of a nameplate for H250 M40 (ATEX)

Nameplate H250/M40, DK37/M8M, DK37/M8M/R, H250/M8MG, H250/M8MG/R



Figure 2-11: Example of a nameplate for H250 M40 (UKCA)

Nameplate VA40, GA24, DK46, DK47, DK48, DK800

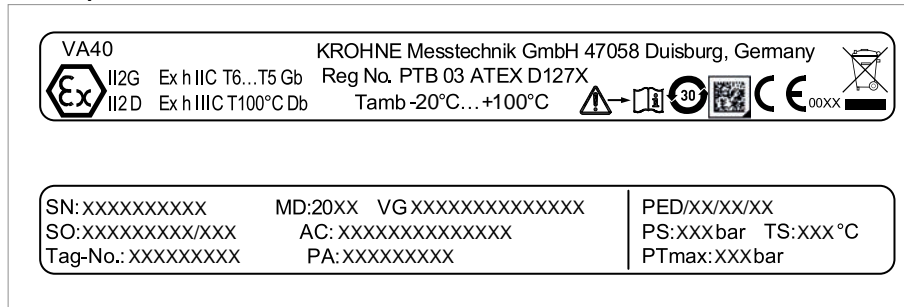

Figure 2-12: Example of a nameplate for VA40 (ATEX)

Nameplate VA40, GA24, DK46, DK47, DK48, DK800

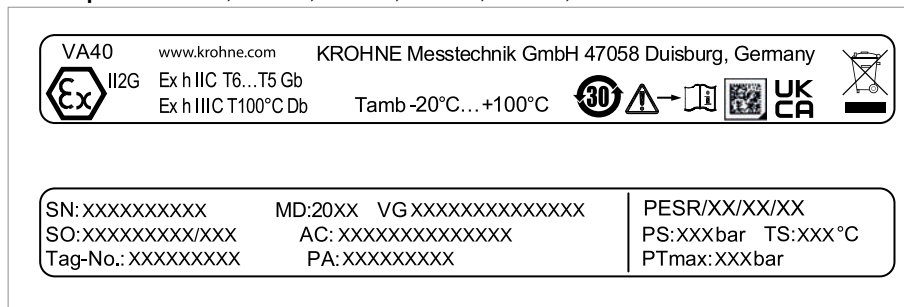

Figure 2-13: Example of a nameplate for VA40 (UKCA)



CAUTION!

The values stated on the nameplates (indicated with XXX) vary according to the individual device versions and can be found on the respective nameplate or standard manual for the device.

- SN - serial number and/or PA - production order number
- MD - manufacturing date
- PS - max. operating pressure (Pressure Specified)
- PT max. - max. test pressure (Pressure Test max.)
- TS - max. operating temperature (Temperature Specified)
- PED / PESR - Pressure Equipment Directive / Pressure Equipment Safety Regulation
- Tag-No. - tag identifier
- Reg.No. - registration number
- Tamb. - max. ambient temperature
- VG - V number, Germany
- SO - order number
- PA - production order number
- AC - article code

2.4 Flammable products

Atmospheric conditions:

The standard atmospheric conditions under which it may be assumed that Ex equipment can be operated are:

- Temperature: -20...+60°C / -4...+140°F
- Pressure: 80...110 kPa (0.8...1.1 bar) / 11.6...15.9 psi
- Air with normal oxygen content, typically 21%v/v

Ex equipment operating outside the standard temperature range must be tested and certified (e.g. for ambient temperature range -40...+65°C / -40...+149°F).

Ex equipment operating outside the standard atmospheric pressure range and standard oxygen content is not permitted.

Operating conditions:

The measuring unit of variable area flowmeters operate outside the standard atmospheric pressure range, which means that explosion protection, regardless of the zone assignment, is fundamentally not applicable for the measuring unit (piping).



WARNING!

Operation with flammable products is only permitted as long as no explosive fuel/air mixture builds up inside of the piping at the same time the atmospheric conditions are exceeded.

The operator is responsible to ensure that the flowmeter is operated safely in terms of the temperature and pressure of the products used. In case of operation with flammable products the measuring units must be included in the periodic pressure tests of the piping.

The max. allowable operating pressure PS printed on the nameplate is to be considered.

The following versions require dust-free gases or liquids. Gases containing solid particles or liquid droplets are not permitted. The products must reach the stated minimum conductivity. The limit of the stated maximum nominal flow rate must be observed.

Device type	Minimum conductivity in $\mu\text{S/m}$	Maximum flow rate Q_{max}
H250/C...	0.01	-
VA40	0.001	5-times
GA24	-	10-times
DK46 / DK47 DK48 / DK800	-	20-times
DK46PV / DK47PV DK48PV / DK800PV	0.001	20-times

Table 2-1: Minimum conductivity of product and maximum flow for the device type

2.5 Equipment category

Variable area flowmeters are designed in category II 2 G / II 2 D for use in zone 1 or zone 2 or zone 21 or zone 22. The inside of the measuring unit is also approved for zone 1.



INFORMATION!

Definition of zone 1:

An area in which an explosive atmosphere, as a result of the mixture of flammable substances in the form of gas, steam or mist with air, under normal operation may occasionally occur.

Definition of zone 21:

An area in which an explosive atmosphere may occasionally occur in the form of a cloud of flammable dust in the air under normal operation.

2.6 Types of protection

Non-electrical variable area flowmeters are designed in the protection type "design safety c" in accordance with ISO 80079-37.

The marking of the non-electrical versions for the device type is:

Device type	Gas range	Dust range
DK32 / DK34 / DK37	II 2G Ex h IIC T6...T3 Gb	II 2D Ex h IIIC T150°C Db
DK32 HT / DK34 HT H250/M8MG	II 2G Ex h IIC T6...T3 Gb	II 2D Ex h IIIC T200°C Db
H250/M40 / H250/M40R	II 2G Ex h IIC T6...T2 Gb	II 2D Ex h IIIC T300°C Db
H250/M40 HT / H250/M40R HT	II 2G Ex h IIC T6...T1 Gb	II 2D Ex h IIIC T450°C Db
DK46 / DK47 / DK48 / DK800 VA40	II 2G Ex h IIC T6...T5 Gb	II 2D Ex h IIIC T100°C Db
GA24	II 2G Ex h IIC T6...T4 Gb	II 2D Ex h IIIC T120°C Db

Table 2-2: Marking of the non-electrical versions for the device type

The marking contains the following information:

II	Explosion protection, group II
2	Equipment category 2
G	Gas explosion protection
D	Dust ignition protection
Ex h	Non-electrical device - Protection through design safety
IIC	Gas group, suitable for gas groups IIC, IIB and IIA
IIIC	Dust group, suitable for groups IIIC, IIIB and IIIA
T6...T2	Temperature class range, suitable for temperature classes T6...T1
T300°C	Maximum surface temperature of measuring unit
Gb	EPL, suitable for zone 1 and zone 2
Db	EPL, suitable for zone 21 and zone 22

Table 2-3: Description of the marking

2.7 Ambient temperature / Product temperature

Due to the influence of the product temperature, no fixed temperature class is assigned to variable area flowmeters. The temperature class of these devices is rather a function of the present product temperature and ambient temperature.

The correlation of the temperature class as a function of the ambient temperature and the process temperature is shown separately for each type series in the following table. The permissible ambient temperatures and process temperatures can be reduced for functional reasons.

Device type	Temp. class	Surface temperature	Maximum permissible	
			Ambient temperature in °C	Product temperature in °C
DK32 / DK34	T6	T85°C	-40...+70	-40...+85
	T5	T100°C		-40...+100
	T4	T135°C		-40...+135
	T3	T150°C		-40...+150
DK32 HT / DK34 HT	T6	T85°C	-25...+85	-25...+85
	T5	T100°C	-25...+100	-25...+100
	T4	T135°C	-25...+135	-25...+135
	T3	T200°C	-25...+200	-25...+200
DK37 / M8M	T6	T85°C	-40...+70	-40...+85
	T5	T100°C		-40...+100
	T4	T135°C		-40...+135
	T3	T150°C		-40...+150
H250 / M8MG	T6	T85°C	-40...+70	-40...+85
	T5	T100°C		-40...+100
	T4	T135°C		-40...+135
	T3	T200°C		-40...+200
H250 / M40 H250 / M40R H250 / M40 HT H250 / M40R HT	T6	T85°C	-40...+70	-40...+85
	T5	T100°C		-40...+100
	T4	T135°C		-40...+135
	T3	T200°C		-40...+200
H250 / M40	T2	T300°C	-40...+50	-40...+300
H250 / M40R			-40...+65	
H250 / M40 HT H250 / M40R HT			-40...+70	
H250 / M40R HT			-40...+120 Stainless steel type plate	
H250 / M40 HT H250 / M40R HT	T1	T450°C	-40...+70	-40...+450
H250 / M40R HT			-40...+120 Stainless steel type plate	
DK46 / DK47 DK48 / DK800	T6	T85°C	-20...+85	-5...+85
	T5	T100°C	-20...+100	-5...+100

Device type	Temp. class	Surface temperature	Maximum permissible	
			Ambient temperature in °C	Product temperature in °C
VA40	T6	T85°C	-20...+85	-20...+85
	T5	T100°C	-20...+100	-20...+100
GA24	T6	T85°C	-20...+85	-40...+85
	T5	T100°C	-20...+100	-40...+100
	T4	T120°C		-40...+120

Table 2-4: Temperature class and surface temperature in °C

Device type	Temp. class	Surface temperature	Maximum permissible	
			Ambient temperature in °F	Product temperature in °F
DK32 / DK34	T6	T185°F	-40...+158	-40...+185
	T5	T212°F		-40...+212
	T4	T275°F		-40...+275
	T3	T302°F		-40...+302
DK32 HT / DK34 HT	T6	T185°F	-25...+185	-25...+185
	T5	T212°F	-25...+212	-25...+212
	T4	T275°F	-25...+275	-25...+275
	T3	T392°F	-25...+392	-25...+392
DK37 / M8M	T6	T185°F	-40...+158	-40...+185
	T5	T212°F		-40...+212
	T4	T275°F		-40...+275
	T3	T302°F		-40...+302
H250 / M8MG	T6	T185°F	-40...+158	-40...+185
	T5	T212°F		-40...+212
	T4	T275°F		-40...+275
	T3	T392°F		-40...+392
H250 / M40 H250 / M40R H250 / M40 HT H250 / M40R HT	T6	T185°F	-40...+158	-40...+185
	T5	T212°F		-40...+212
	T4	T275°F		-40...+275
	T3	T392°F		-40...+392
H250 / M40 H250 / M40R H250 / M40 HT H250 / M40R HT	T2	T572°F	-40...+122	-40...+572
			-40...+149	
			-40...+158	
			-40...+248 Stainless steel type plate	
H250 / M40 HT H250 / M40R HT	T1	T842°F	-40...+158	-40...+842
			-40...+248 Stainless steel type plate	
DK46 / DK47 DK48 / DK800	T6	T185°F	-20...+185	-5...+185
	T5	T212°F	-20...+212	-5...+212

Device type	Temp. class	Surface temperature	Maximum permissible	
			Ambient temperature in °F	Product temperature in °F
VA40	T6	T185°F	-20...+185	-20...+185
	T5	T212°F	-20...+212	-20...+212
GA24	T6	T185°F	-20...+185	-40...+185
	T5	T212°F	-20...+212	-40...+212
	T4	T248°F		-40...+248

Table 2-5: Temperature class and surface temperature in °F

2.8 Surface temperature

It is to be assumed that a combustible fuel / air mixture can be in contact with the outer wall of the measuring tube and process connections. Any temperature gradient between the internal wall in contact with the product (product temperature) and the outer surface is not taken into consideration.

The actual maximum surface temperature does not depend on the device itself, but instead on the operating conditions. The device itself does not generate heat and, for this reason, the surface temperature is determined by the product temperature and, in versions with heating jackets, by the heating medium temperature as well.

The nameplate shows the maximum values of the temperature classes and the maximum surface temperature. Depending on the device version, these values may not be reached. The maximum permitted ambient and product temperatures can be found in the standard manual.

2.9 Ignition hazard assessment / protective measures

Non-electrical variable area flowmeters were subject to an ignition hazard assessment in accordance with ISO 80079-36. The following table lists the ignition hazards considered and the protective measures carried out or to be carried out by the operator.

Device type	Ignition hazard	Constructive protective measures	Construction site protective measures (note special conditions!)
All versions	Electrostatics	Electrostatic connection between conductive components, ground connection device	Include device in the equipotential bonding of the hazardous area. For installations in hazardous areas of group IIC, observe the notes for the elimination of electrostatic charge.
	Impact of sparking in measuring units	Float stop in measuring unit	Eliminate pressure surges in pipelines.
	Impact of sparking on surfaces	Materials (without titanium)	None
	Shock resistance Glass cones	Tests with low energy	If the degree of mechanical risk is higher, protective measures on-site must be taken.
	Shock resistance Metal cones	Tests with high energy	None
	Surface temperatures	None, as no self-warming occurs	Note max. permissible product and ambient temperatures.
	Oxygen in conjunction with titanium measuring units	None	Products with an oxygen content higher than 21% V/V are not permitted.
H250 M40 / H250 M8MG	Impact of sparking on titanium surfaces	Marking in the type marking (Ti)	Equipment with titanium surfaces may only be used in shock-resistant areas.
DK32 / DK34 / DK37		Marking with material code (e. g. 3.7025, 3.7035 or 3.7055) on the measuring unit	
H250/C...	Electrostatics	Minimum conductivity of the medium $\geq 10^{-8}$ S/m	Note the minimum conductivity of the medium.
VA40		Min. conductivity for liquids $\geq 10^{-9}$ S/m Flow rate $\leq 5 * V_{max}$ with dust-free gases and liquids	Note the minimum conductivity of the medium. Note the maximum flow rate.
GA24		Flow rate $\leq 10 * V_{max}$ with dust-free gases and liquids	Note the maximum flow rate.
DK46 / DK47 DK48 / DK800		Flow rate $\leq 20 * V_{max}$ with dust-free gases and liquids	
DK46PV / DK47PV DK48PV / DK800PV		Min. conductivity for liquids $\geq 10^{-9}$ S/m Flow rate $\leq 20 * V_{max}$ with dust-free gases and liquids	Note the minimum conductivity of the medium. Note the maximum flow rate.
DK3x HT..	Corrosion	None	Exclude corrosive environmental conditions.

Table 2-6: Ignition hazard assessment / protective measures

3.1 Mounting

Mounting and setup must be carried out according to the applicable installation standards by qualified personnel trained in explosion protection.

The information given in the manual and the supplementary instructions must always be observed.

Variable area flowmeters must be installed in such a way that

- there is no danger from mechanical impact effects.
- there are no external forces affecting the indicator part.
- the device is accessible for any necessary visual inspections and can be viewed from all sides.
- the nameplate is clearly visible.
- it can be operated from a location with secure footing.



CAUTION!

The manufacturer is not liable for any damage resulting from improper use or use other than the intended purpose. This applies in particular to hazards due to insufficient corrosion resistance and suitability of the materials in contact with product.



DANGER!

Components made of titanium in oxygen applications

*Variable area flowmeters with titanium components are **NOT** suitable for use in explosion-protected areas in conjunction with oxygen applications (products with an oxygen content which is significantly above the oxygen content in the earth's atmosphere)!*

3.2 Special conditions

Equipotential bonding

Variable area flowmeters must be included in the equipotential bonding of the hazardous area. For further information refer to *Grounding and equipotential bonding* on page 18.

Electrostatics

If the installation takes place in hazardous areas of group IIC, the instructions for electrostatics must be observed.

For further information refer to *Static electricity* on page 21.

Mechanical tests

All-metal design:

Variable area flowmeters are tested on measuring units, optional valves and controllers for shock resistance with 4 Joules in accordance with ISO 80079-36 for device group II with a low degree of mechanical risk. The sight glass is not tested on all-metal variable area flowmeters. The integrity of the sight glass is not relevant to explosion protection on these devices. If the degree of mechanical risk is higher, additional protective measures must be taken on-site.

Glass devices:

Variable area flowmeters are tested on measuring units, transparent sight glasses and controllers and protective covers for shock resistance with 4 or 2 Joules in accordance with ISO 80079-36 for device group II with a low degree of mechanical risk. If the degree of mechanical risk is higher, additional protective measures must be taken on-site.

Flammable products

Observe the safety instructions when operating with flammable products.
For further information refer to *Flammable products* on page 11.

Measuring units with titanium components

Observe the information regarding installation and safe operation.
For further information refer to *Mounting* on page 17 and refer to *Operation* on page 21.

Unpainted indicators

Unpainted DK3x..HT indicators must not be used in corrosive environments.

3.3 Grounding and equipotential bonding

If the device is not sufficiently electrostatically grounded via the process pipes, an additional ground connection must be established using the ground terminal ① or ② .
The location of the ground terminal is shown below according to type. This connection only ensures electrostatic grounding of the device and does not meet the requirements for equipotential bonding.

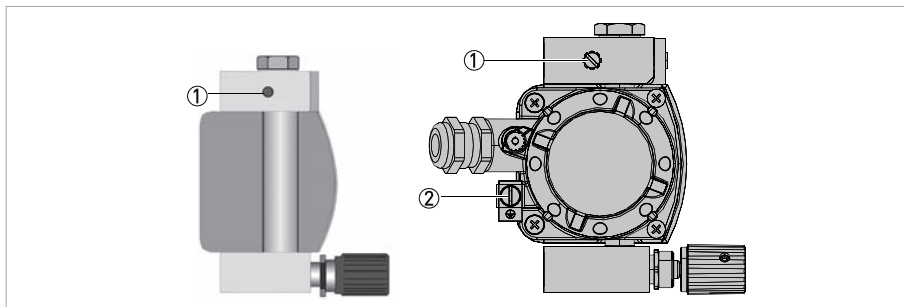

Figure 3-1: Ground terminal for DK3. mechanical flowmeter or DK32 with ESK3x transmitter

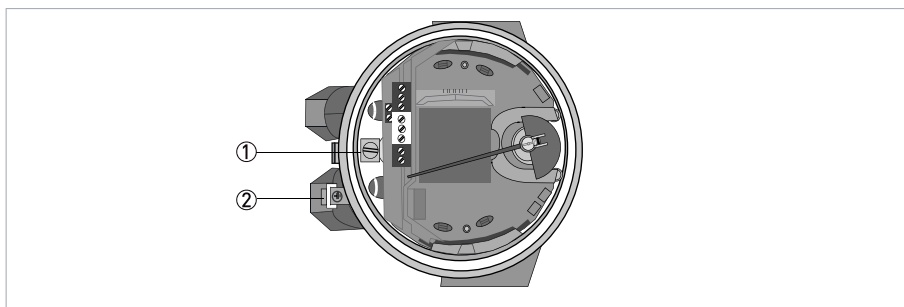

Figure 3-2: Ground terminal for H250/M40

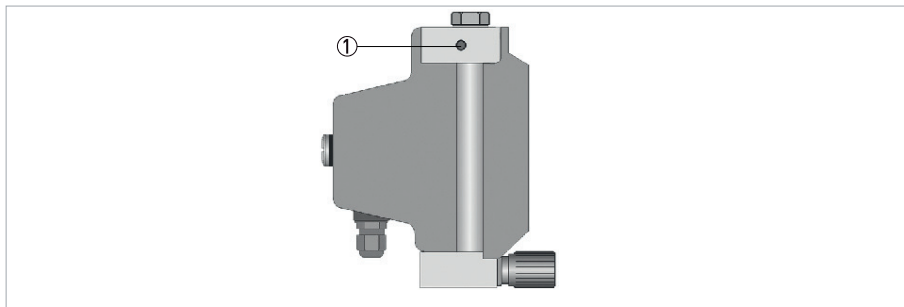

Figure 3-3: Ground terminal for DK37/M8M

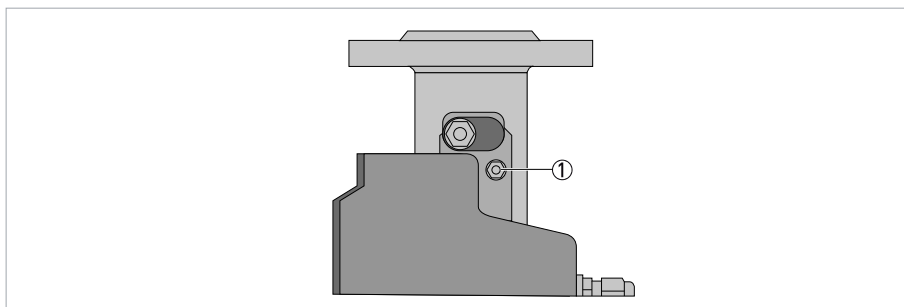

Figure 3-4: Ground terminal for H250/M8MG



INFORMATION!

The indicator housing of M8M is made of conductive plastic. Friction cannot cause electrostatic charge.

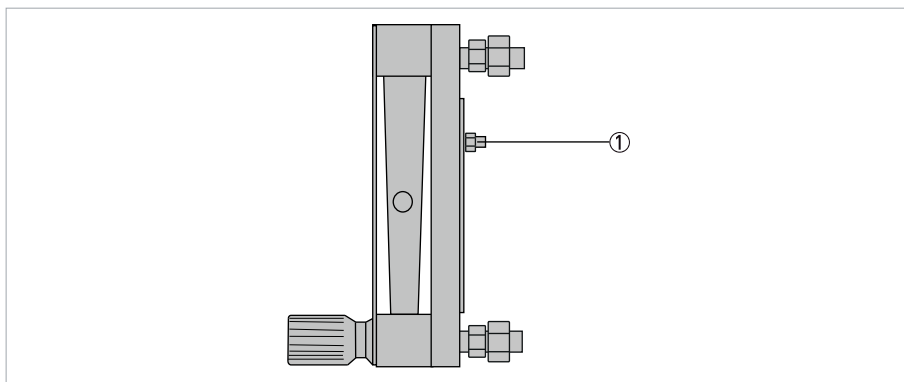

Figure 3-5: Ground terminal for DK46 / DK47 / DK 48 / DK800

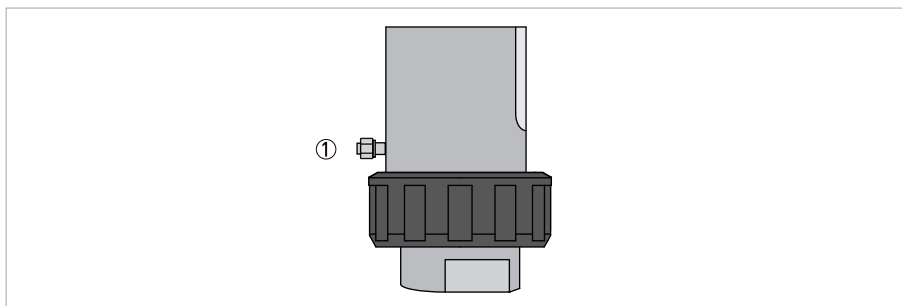

Figure 3-6: Ground terminal for VA40

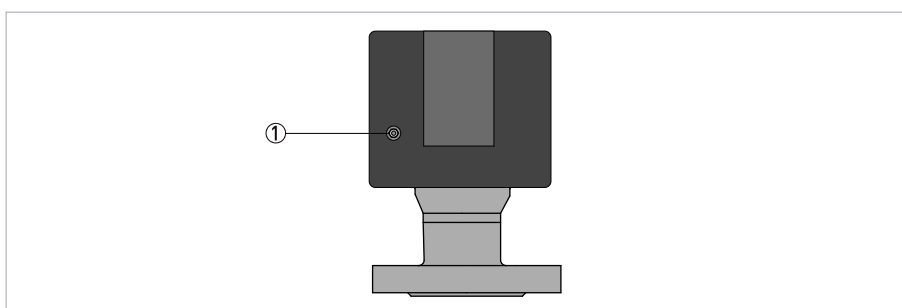

Figure 3-7: Ground terminal for GA24



INFORMATION!

The grounding ① and ② are equivalent.



INFORMATION!

The temperature at the electrostatic equalisation connector on the DK32, DK34 and DK37 measuring units corresponds to the process temperature. It is thus the responsibility of the operator to select the connecting cable according to the process temperature.

4.1 Start-up

Make the following checks before starting up the device:

- Check that it has been correctly mounted and connected to the system.
- Check that it is in proper state with regard to the installation requirements.
- Suitability of the materials used for the measuring unit and for the gaskets for adequate resistance to corrosion from the product.

The operator of the system has to check prior to start-up, if the start-up was in compliance with the national regulations for checks.

4.2 Operation

Variable area flowmeters must be operated in such a way that they remain within the maximum and minimum permissible temperatures and pressures.

Variable area flowmeters may only be operated if the equipment parts necessary for safety are effective in the long run, and are not rendered inoperable during operation.

In case of flammable products the measuring units must be included in the periodic pressure tests of the system.



WARNING!

Avoid ignition risks caused by pressure surges, impact or friction, particularly when using titanium measuring units (material number 3.7025, 3.7035 or 3.7055 on pressurised parts).

4.3 Static electricity

4.3.1 Electrostatic charge caused by ambient conditions

In order to avoid ignition hazards due to electrostatic charge, variable area flowmeters may not be used in areas with:

- processes that generate strong charges,
- mechanical friction and cutting processes,
- spraying of electrons (e.g. in the vicinity of electrostatic painting systems) or
- pneumatically conveyed dust is exposed.

4.3.2 Charging non-conductive external parts by cleaning

Area limits are taken into consideration with respect to the chargeability of non-conductive external parts under atmospheric conditions.

Devices of type VA40 for which it can be expected that combustible electrostatic charging will occur due to cleaning are marked with a warning label:



CAUTION!

Attention! Risk of electrostatic charge! Do not rub!

A cleaning cloth moistened with water, for example, should be used to clean surfaces that could be loaded with a charge.

4.3.3 Process dependent charging

In variable area flowmeters, it is possible under field conditions for charge separation to occur in the measuring tube due to the transport of non-conductive fluids and/or when the flow comes into contact with non-conductive built-ins (e.g. liners, floats).

For all metal devices, the measuring tube and the welded on process connections form a shield (Faraday cage) from which the electrical field cannot escape.

In glass devices, it is basically possible for the electrostatic field generated inside the measuring tube to "punch through" to the outside of the device. For that reason, variable area flowmeters need to be permanently grounded by the operator via the process connections in order to allow discharge of electrostatic charges.

The operator is also responsible for continuing the complete grounding of the process line. If grounding cannot be made via the process connections (plastic process connections or undefined connections), the measuring device should be connected to the described ground potential via the connection to ground. This connection only ensures the electrostatic grounding of the device and does not meet the requirements for equipotential bonding.

5.1 Dismantling

Replacing the indicator

Due to the modular design of the variable area flowmeters with metal measuring units, from a safety perspective it is possible to replace a complete indicator with an identical spare part.



CAUTION!

There may be a loss of measuring accuracy!

Exchanging the entire device

The dismantling and installation is within the responsibility of the operator.



CAUTION!

- *Pressurised pipes have to be depressurised before removing the measuring unit.*
- *In the case of environmentally critical or hazardous products, appropriate safety precautions must be taken with regard to residual liquids in the measuring unit.*
- *New gaskets have to be used when re-installing the device in the pipeline.*

5.2 Maintenance

Maintenance work of a safety-relevant nature within the meaning of explosion protection may only be carried out by the manufacturer, his authorised representative or under the supervision of authorised inspectors.

For systems in hazardous areas, regular checks are required in order to maintain the proper condition.

The following checks are recommended:

- Check the housing for corrosion or damage.
- Check the measuring unit and the piping connections for leakage.
- Check the measuring unit and the indicator for dust deposits.
- Include the flowmeter in the periodic pressure test of the process line.

During re-assembly after maintenance of the indicator (or replacement) or the flowmeter, the operator must take appropriate measures to ensure that

- no charge is applied to the surface of the housing.
- no charge is applied to the inner surfaces of the housing.
- any damaged gaskets are replaced.

The cover is to be closed following maintenance work on the M40 indicator.

Cleaning the measuring unit

Depending on the application, worst-case operating conditions may lead to reduced measuring performance as a result of fouling of the measuring system. Clean the measuring unit in accordance with the standard manual for non explosion-protected versions.

The measuring unit must be dismantled for cleaning. This dismantling will need to be coordinated with operating conditions (e.g. check for existence of a flammable liquid or explosive atmosphere in or at the tank or pressurised tank) and is within the responsibility of the operator.

To do this, follow the instructions for exchanging the entire device (for details refer to *Dismantling* on page 23).

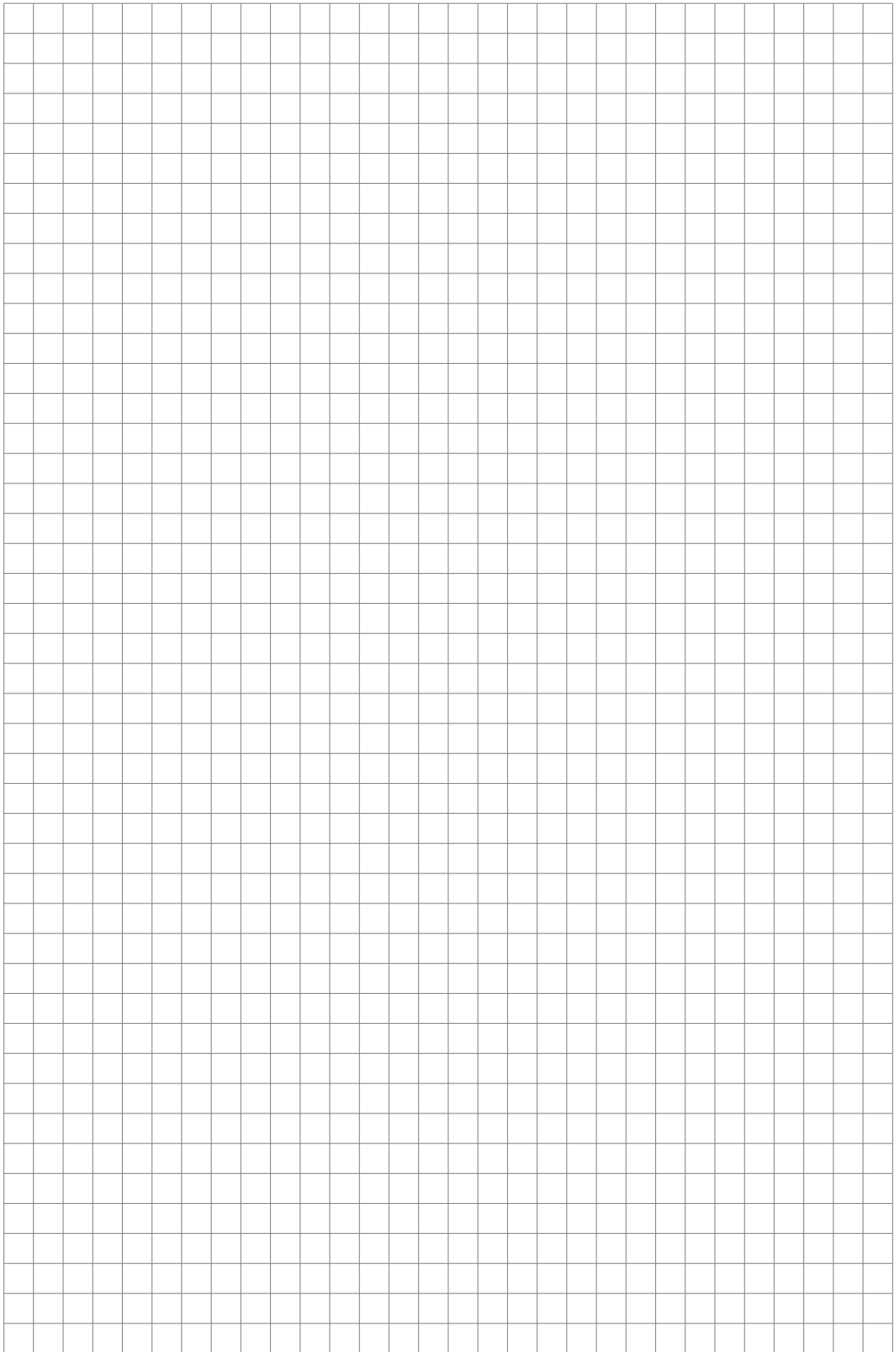

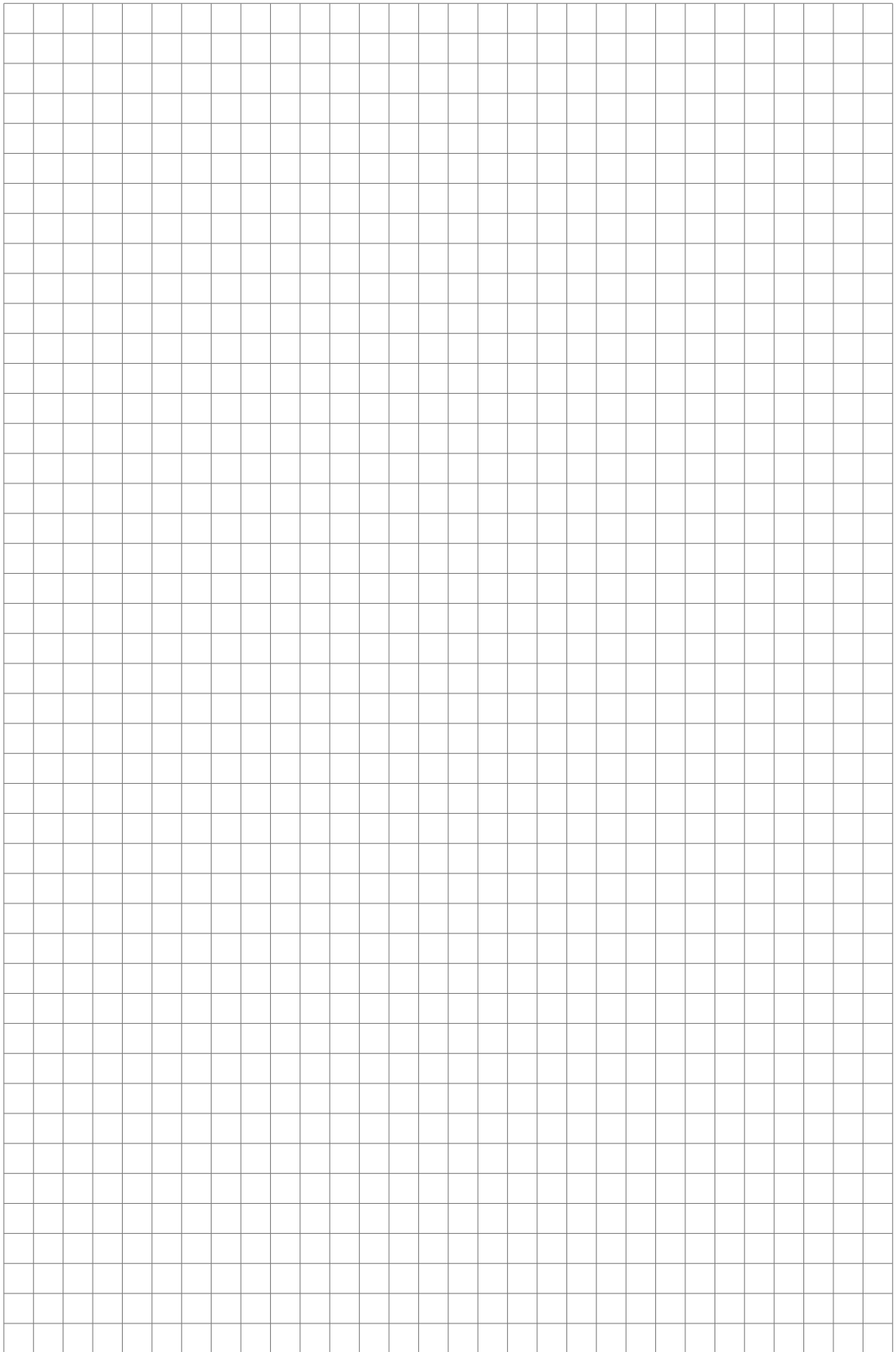

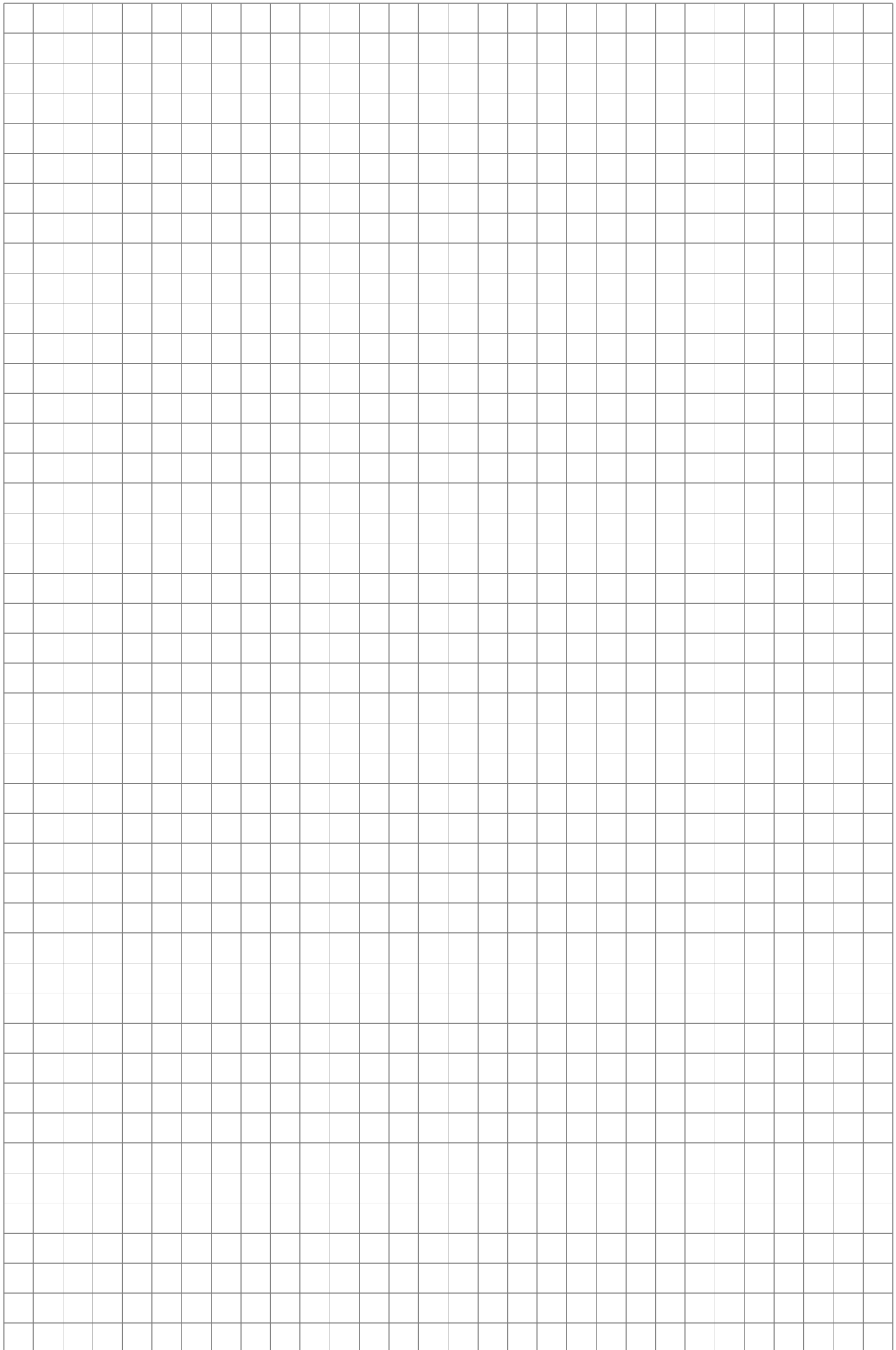

KROHNE – Products, Solutions and Services

- Process instrumentation for flow, level, temperature, pressure measurement and process analytics
- Flow metering, monitoring, wireless and remote metering solutions
- Engineering, commissioning, calibration, maintenance and training services

Head Office KROHNE Messtechnik GmbH
Ludwig-Krohne-Str. 5
47058 Duisburg (Germany)
Tel.: +49 203 301 0
Fax: +49 203 301 10389
info@krohne.de

The current list of all KROHNE contacts and addresses can be found at:
www.krohne.com

