

Installation and operating handbook

Optimass Series of Mass Flowmeters and 050/051 Converters

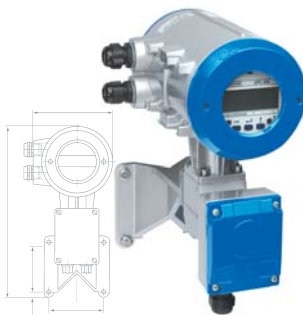
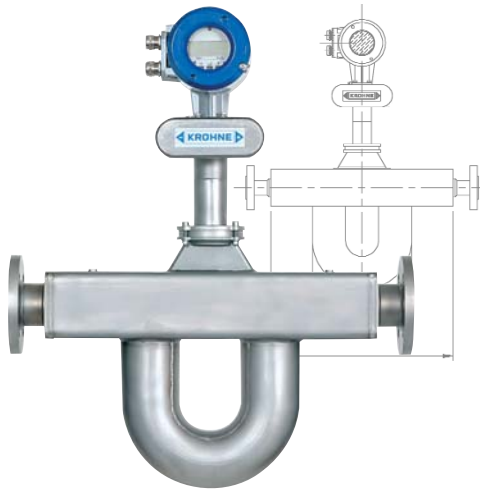

Electromagnetic flowmeters

Variable area flowmeters

Mass flowmeters

Ultrasonic flowmeters

Vortex flowmeters

Flow controllers

Level measuring instruments

Pressure and temperature

Heat metering

Communications technology

Switches, counters, displays and recorders

Engineering systems & solutions

Contents

1	MECHANICAL INSTALLATION	6
1.1	General principles	6
1.1.1	Transport and Lifting	8
1.2	OPTIMASS 7000 Single Straight Tube Meter	9
1.2.1	Specific Installation Guidelines	9
1.2.2	Ambient / Process temperatures	9
1.2.3	Pressure Equipment Directive (PED) requirements	9
1.2.4	Secondary Pressure containment	10
1.2.5	Pressure de-rating	10
1.2.6	Hygienic Applications	13
1.2.7	Heating and insulation	14
1.2.8	Purge Port Meters and Burst Disk Meters	18
1.2.9	Technical Data	19
1.2.10	Weights & Dimensions	20
1.3	OPTIMASS 3000 (7100) Single Z Shaped Tube Meter	23
1.3.1	Specific Installation Guidelines	23
1.3.2	Ambient / Process temperatures	24
1.3.3	Pressure Equipment Directive (PED) requirements	24
1.3.4	Secondary Pressure containment	25
1.3.5	Pressure de-rating	25
1.3.6	Heating and insulation	26
1.3.7	Purge Port Meters and Burst Disk Meters	26
1.3.8	Technical Data	27
1.3.9	Weights & Dimensions	28
1.4	OPTIMASS 8000 / 9000 Meter with Twin U Measuring Tubes	30
1.4.1	Specific Installation Guidelines	30
1.4.2	Ambient / Process temperatures	30
1.4.3	Pressure Equipment Directive (PED) requirements	30
1.4.4	Secondary Pressure containment	31
1.4.5	Pressure de-rating	31
1.4.6	Hygienic Applications	33
1.4.7	Heating and insulation	34
1.4.8	Purge Port Meters and Burst Disk Meters	35
1.4.9	Technical Data	35
1.4.10	Weights & Dimensions	35
2	ELECTRICAL INSTALLATION	39
2.1	Location and connecting cables	39
2.2	Connection to power	39
2.2.1	Power Supply Wiring MFC050	39
2.2.2	Power Supply Wiring MFC051 Non Ex	39
2.2.3	Power Supply Wiring MFC 051 Ex	40
2.3	Connection of remote meters	40
2.4	Hazardous Area requirements	41
2.5	Inputs and outputs	41
2.5.1	Inputs/Outputs MFC 050	41
2.5.2	Inputs / Outputs MFC051	46
2.6	Compact to Remote / Remote to Compact conversion instructions	48
2.7	Technical Data	48
2.7.1	MFC050	48
2.7.2	MFC051	49
3	START-UP	50
3.1	Factory Set Parameters	50
3.2	Initial Start-up	50
3.3	Zero point adjustment	51
3.4	Programming the converter with a bar magnet	51

4	PROGRAMMING THE CONVERTER MFC 050/051	52
4.1	Operating and check elements	52
4.2	OPTIMASS MFC 050/051 Operating Concept	53
4.3	Key functions	54
4.3.1	How to enter programming mode	55
4.3.2	How to terminate Programming mode	55
4.4	Table of programmable functions	58
4.5	Reset / Quit Menu - Totalizer reset and status indication acknowledgement	67
5	DESCRIPTION OF FUNCTIONS	68
5.1	Menu 1 - Initial Start up	68
5.2	Menu 2 – Functional Checks	74
5.3	Menu 3- Configuration Menu	78
5.4	Menu 4 - I/O Configuration	86
5.5	Menu 5 - Factory Settings	91
6	SERVICE AND TROUBLE SHOOTING	93
6.1	Diagnostic functions	93
6.2	Error Messages	94
6.3	Functional Tests and Troubleshooting	95
6.4	Replacing the Front End or Back End Electronics	97
6.4.1	Replacing the Front End	97
6.4.2	Replacing the Back End	98
6.5	Spares	99
7	EXTERNAL STANDARDS AND CODES	101
7.1	Standards	101
7.1.1	Mechanical	101
7.1.2	Electrical	101
7.2	Declaration of Conformity	102
7.3	PED Certificate	103
8	DEVICE CONFIGURATION SHEET	105
9	DECLARATION OF CLEANLINESS CERTIFICATE	107

How to use these installation and operating instructions

Congratulations on purchasing this high quality product. To get the best out of your mass flowmeter, please take some time to read through the instructions.

This instruction handbook is comprehensive and describes the many features and options available with this mass flow meter.

Please refer to the index for a list of detailed topics.



Note:

If applicable, a separate document is supplied that describes all ATEX hazardous area information.

Product liability and warranty

The OPTIMASS mass flow meter family is designed for the direct measurement of mass flow rate, product density and product temperature, and also indirectly enables measurement of parameters such as total mass, concentration of dissolved substances and the volume flow.

For use in hazardous areas, special codes and regulations are applicable which are specified in the section on Hazardous Area Installations.



Responsibility as to suitability and intended use of our instruments rests solely with the purchaser. The supplier does not accept any liability resulting from misuse by the customer.

Improper installation and operation of the flow meters may lead to loss of warranty. Warranty is also null and void if the instrument is damaged or interfered with in any way.

In addition, the "general conditions of sale" which forms the basis of the purchase agreement are applicable.

If you need to return OPTIMASS flow meters to KROHNE, please complete the form on the last page of the installation and Operating manual and return it with the meter to be repaired. KROHNE regrets that it cannot repair or check your flow meter unless accompanied by this completed form.

CE / EMC Standards /Approvals

- The OPTIMASS family with the MFC 050 / 051 / 010 signal converter meets all the requirements of the EU-EMC and PED Directives and bears the CE Symbol.
- The OPTIMASS system is approved for hazardous duty installations to the harmonised European Standards (ATEX) to Factory Mutual (FM) and CSA (Canadian Standards).

Technical data subject to change without notice

Unpacking the meter

When unpacking your meter, please ensure that no visible damage has occurred during transportation. If damage has occurred, please contact the carrier for claims.

Your high quality instrument has been fully tested and checked before shipping. The following items should be included with your instrument unless otherwise requested:

1. Mass Flow Meter OPTIMASS
2. Separate Converter with remote converter wall mount (not for compact version)
3. CD-ROM & Quick Start Guides
4. Spanner to open the electronic housing lids
5. Bar magnet for programming the meter
6. Screw driver for terminal connections
7. Calibration certificate
8. Factory and Material certification, if ordered.

If any of these items are missing, please contact your nearest KROHNE Office or representative (see back page).



Attention:

Please read the Handbook before installing the meter.

Many problems are avoided when the simple guidelines in this handbook are followed.

1 Mechanical Installation

1.1 General principles

The OPTIMASS mass flow meters provide high accuracy and excellent repeatability. Narrow band pass digital filtering, and the mathematically modelled internal primary head design with AST (Adaptive Sensor Technology) for the OPTIMASS sensor family provide exceptional immunity to external vibratory disturbances from nearby process equipment.

The accuracy of the flow meter is not affected by velocity profile.

The following installation guidelines are practical to implement, particularly if planned before the OPTIMASS meter is first installed. For further dimensions or connections, please refer to the relevant section.

For the OPTIMASS, in general, no special mounting requirements are necessary. However, good general engineering practice for the installation of flow meters should still be observed.

The general guidelines described in this section are valid for the complete OPTIMASS family of mass flow meters.

- The mass flow meters do not require any straight inlet or outlet runs.
- Due to the weight of the meters we recommend the use of supports.
- It is permissible to support the body of the meter.
- The meter can be installed horizontally, in an upward sloping pipeline or vertically. For best results, a vertical installation with flow in an upward direction is recommended.



This label on the meter shows the flow direction programmed into the converter in function 3.1.4. As default this is always in the direction of the '+' arrow, i.e. left-to right as the label is viewed.

Examples

Vertical mounting



Horizontal mounting



Upward sloping installation

Avoid mounting the meter with long vertical drops after the meter. This could cause siphoning and cause measurement errors.

Avoid mounting the meter at the highest point in the pipeline. Air or gas can accumulate here and cause faulty measurements

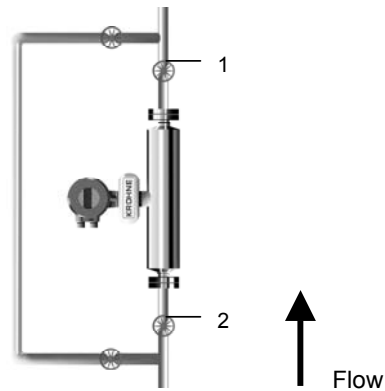
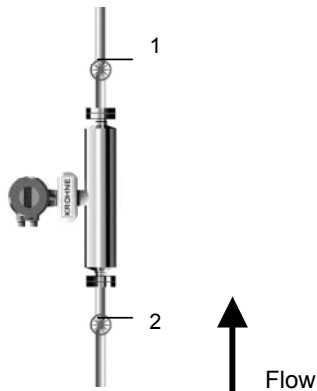
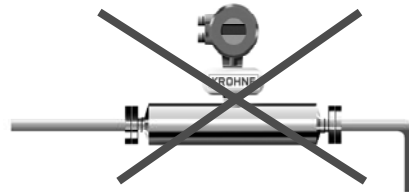

- 1 Valve for zeroing flow meter
- 2 The second valve is recommended if the pump is switched off to prevent reverse flow

To enable a good zero to be done, it is recommended that a shut-off valve be installed downstream of the flow meter.

1.1.1 Transport and Lifting

As the larger meters are heavy, care should be taken when lifting to install.

- Meters should be lifted or suspended using a well maintained sling.
- The meters should under **no** circumstances be lifted by the electronics housings.
- The meters can be lifted and suspended from the spigots as shown.

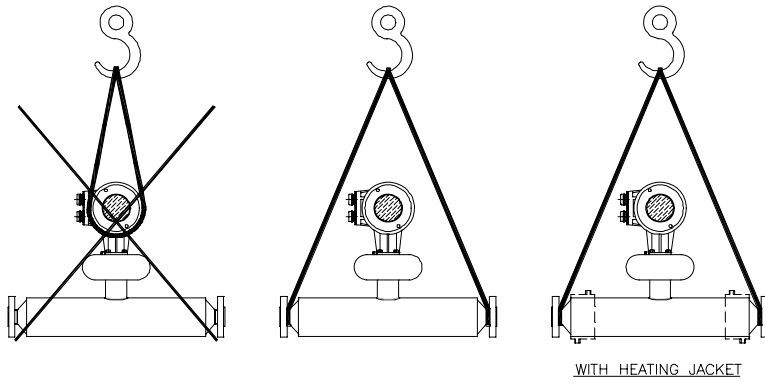

1.2 OPTIMASS 7000 Single Straight Tube Meter

1.2.1 Specific Installation Guidelines

- Tighten flange bolts evenly.
- Observe min and max pipe end loads at end of this section.



The use of reducers at the flanges is allowed. Extreme pipe size reductions should be avoided due to possibility of cavitation and degassing.

There are no additional installation requirements for the OPTIMASS 7000 sensors. Fixing of flexible hoses directly on the meter is allowed.

1.2.2 Ambient / Process temperatures

The specified and approved ambient and process temperatures must be observed.

		Titanium		HC22		SS318L	
		°C	°F	°C	°F	°C	°F
Process		-40 .. +150	-40 .. +300	0 .. +100	0 .. 212	0 .. +100	0 .. 212
		-20°C or 4°F for hygienic or aseptic connections					
Ambient	Compact	-40 .. +55	-40 .. +130	-40 .. +55	-40 .. +130	-40 .. +55	-40 .. +130
	Remote	-40 .. +60	-40 .. +140	-40 .. +60	-40 .. +140	-40 .. +60	-40 .. +140



Note:

Where meters are mounted in direct sunlight, it is recommended to install a sunshade. This is particularly important in countries with high ambient temperatures.

The maximum differential temperature between the process and ambient temperature without insulation is 130°C or 265°F for Titanium and 80°C or 115°F for Hastelloy and Stainless Steel meters.

1.2.3 Pressure Equipment Directive (PED) requirements.

To comply with the requirements of the PED in Europe, the following information is provided to assist the plant engineer in installing the meter.

Measuring tube:	Titanium Grade 9 Hastelloy C22 Stainless SS 318	Sealing Faces:	Titanium Grade 2 Hastelloy C22 Stainless SS 318
-----------------	---	----------------	---

The outer cylinder (Secondary Pressure containment) 304 / 304L is dual certified and with "O" rings in pairs of Viton and hydrogenated nitrile. (Optional outer cylinder of 316/316L).

Wiring feedthrough is made of Epoxy.

Flanges all 316 / 316 L dual certified.

Optional heating jacket 316 / 316L.



Note :

Outer cylinder is in contact with heating medium.

1.2.4 Secondary Pressure containment

The OPTIMASS 7000 meters are supplied with secondary pressure containment as standard.

Allowable maximum secondary containment pressures are 63 bar at 20°C or 914 psig at 70°F

If the user suspects that the primary tube has failed, the unit must be depressurised and removed from service as soon as possible.



Note:

In the 7000 Series there are high pressure feed through seals and 'O' rings that might not be compatible with the process fluid for an extended period if a primary tube fails. It is important to remove the meter ASAP

It is the user's responsibility to ensure that the materials used are compatible with this product. Other 'O' ring materials are available on request.

1.2.5 Pressure de-rating

Meter data plates are stamped with maximum pressure rating (at max. operating temperature) of connection, primary tube or secondary pressure containment (whichever is the lower). Higher pressures may be possible at lower temperatures.

Titanium Tubes and secondary pressure containment is	63 bar at 20°C or 910 psi at 4°F
De-rated to	40 bar at 150°C or 580 psi at 300°F

The titanium tubes could handle a higher pressure, but where this exceeds the pressure rating, a relief or bursting disk has to be fitted to the secondary pressure containment. This can be done as a special. (This is available for meter sizes up to 25 only)

Hastelloy and SS measuring tubes are rated for	50 bar at 20°C or 725 psi at 4°F
De-rated to	40 bar at 100°C or 580 psi at 210°F
Heating Jacket	10 bar at 100°C or 145 psi at 210°F

Pressure Derating

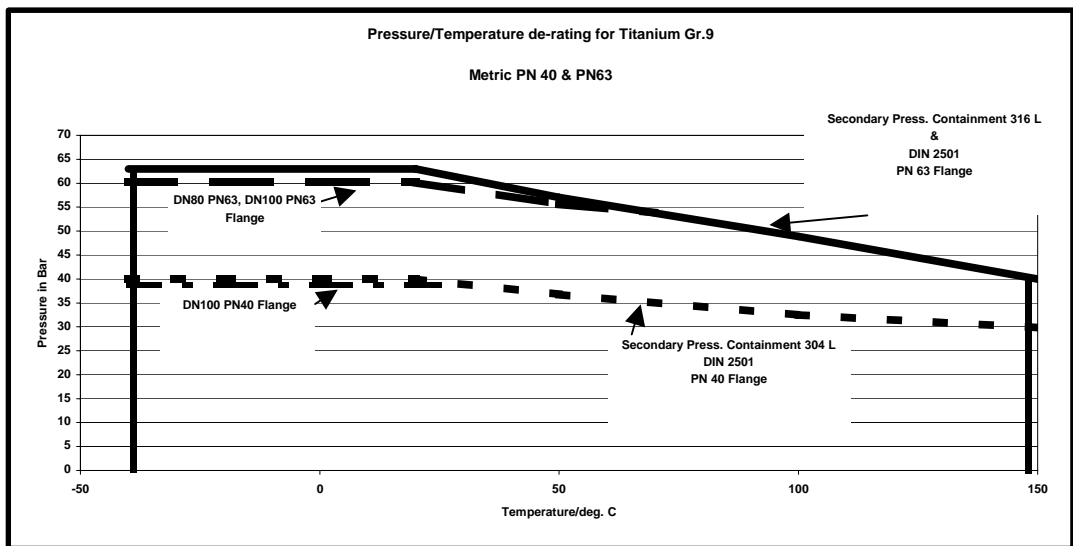

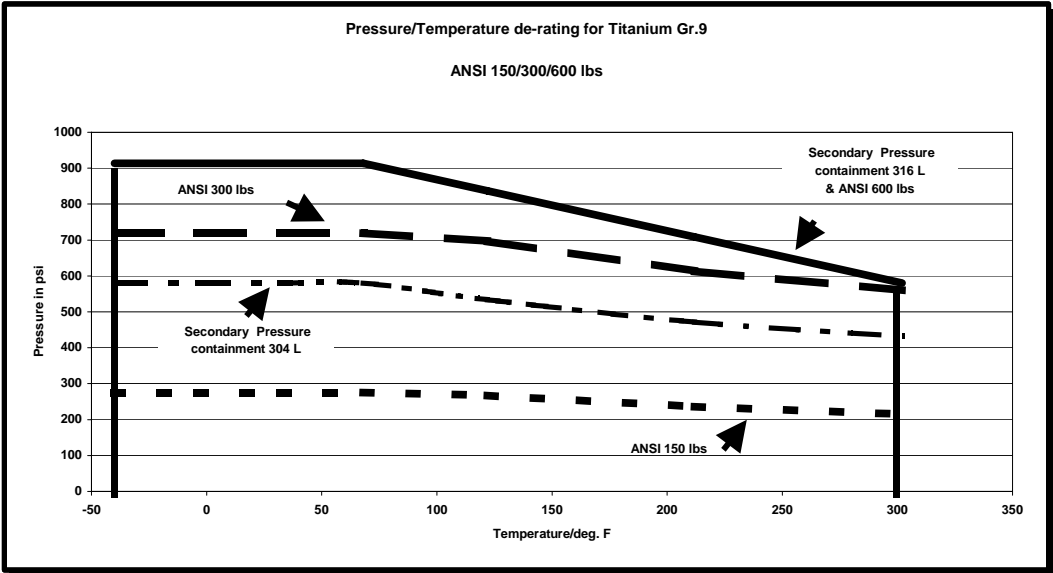
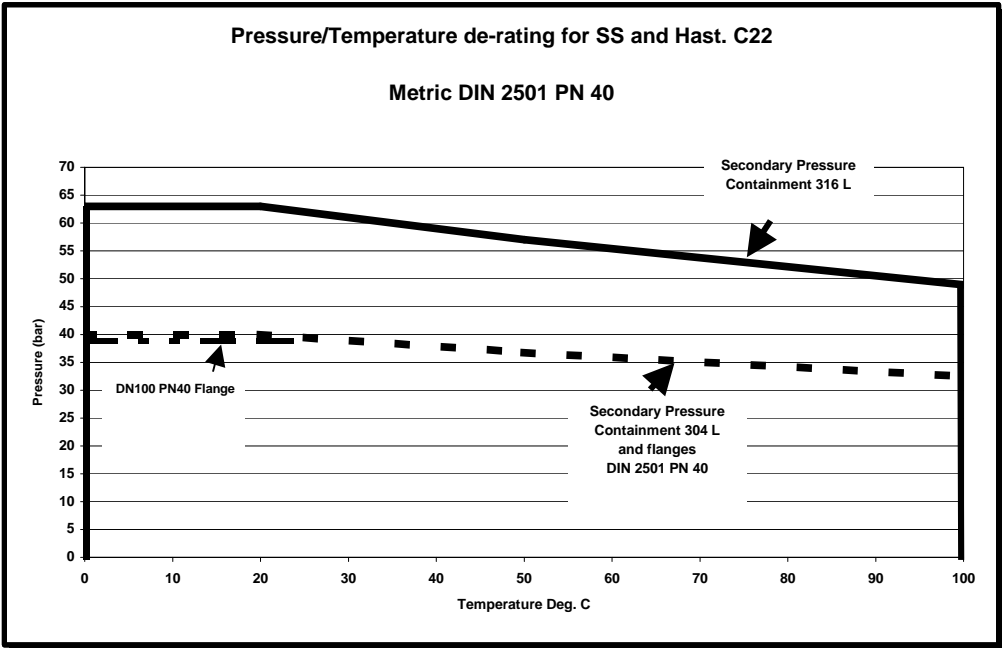

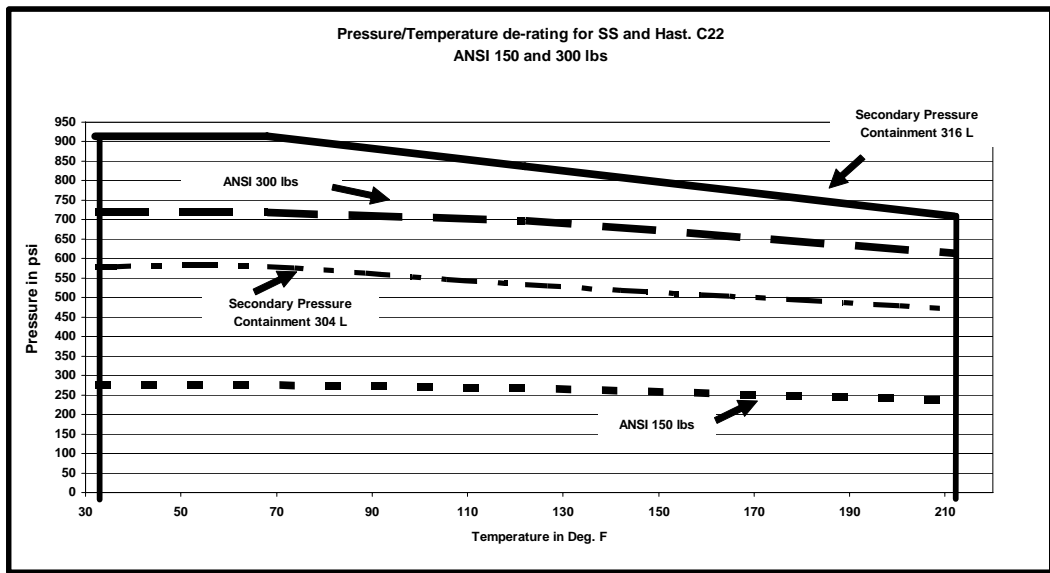

Maximum pipe work forces

The maximum forces exerted on the meter from the pipe work, compressive or tensile has been calculated for the 7000 Series (Straight tube meter) with Titanium, Hastelloy and SS measuring tubes as follows:

Titanium

Size	Max Force: Flanges	Max Force: Hygienic Connectors
06 T	19 KN	1.5 KN
10 T	25 KN	2 KN
15 T*	38 KN	5 KN
25 T	60 KN	9 KN
40 T	80 KN	12 KN
50 T	170 KN	12 KN
80 T	230 KN	30 KN

*On OPTIMASS 15 T with ½" ANSI flanges only – maximum end load is 19 KN.

Hastelloy and SS

Size	Max Force: Flanges	Max Force: Hygienic Connectors
06 S	19 KN	1.5 KN
10 H/S	25 KN	2 KN
15 H/S*	38 KN	5 KN
25 H/S	60 KN	9 KN
40 H/S	80 KN	12 KN
50 H/S	80 KN	12 KN
80 H/S	170 KN	18 KN

*On Optimass 15 H or S with ½" ANSI flanges only – maximum end load is 19 KN

Loads given in both tables are maximum static loads. If loads are cycling, particularly between tension and compression then these loads should be reduced. Please consult KROHNE for more information.

1.2.6 Hygienic Applications

The OPTIMASS 7000 series is available with a variety of hygienic process connectors.

When using / installing meters with hygienic process connectors, care should be taken to ensure the meter is well supported / clamped, as the meters are heavy and could injure when disconnected from the adjacent pipe work.

The recommended method of installation is to mount the meter against a support / wall with the body of the meter supported / clamped. The process pipe work can then be supported off the meter. The meter is too heavy to be supported from the thin walled piping usually associated with the hygienic industry.

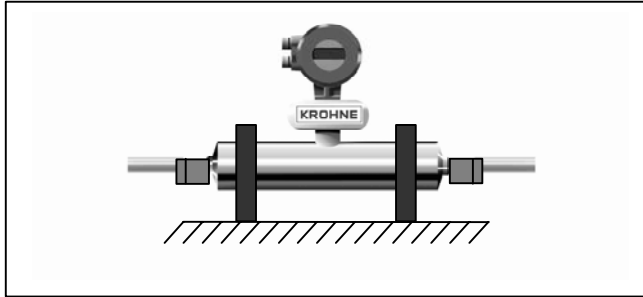

Meter supported from its body

Installation lengths

For installation lengths, please see section 1.2.10

Please check with KROHNE if you are unsure of the installation length. Many meters are built to customer requirements / specifications especially where special hygienic process connectors have been adapted to the meter. As these are normally non-standard, the installation length will not be given in the technical data.

It is also recommended that the seals be replaced regularly to maintain the hygienic integrity of the connection.

Hygienic Connection Materials

Version	Titanium Meter	SS 318 Meter
All welded DIN 11864	Titanium Grade 2	SS 318
All welded Tri-Clamps		
Adaptor versions	316L Stainless Steel EPDM seals	316L Stainless Steel EPDM seals

Unless specifically requested, internal surfaces are not polished and no warranty is made as to the surface finish. If polishing option and /or EHEDG, ASME Bio-Processing or 3A approvals was selected at time of order, all product contact surfaces are polished 0.5 micrometer Ra (Ra 20) finish or better.

Use of OPTIMASS 7000 SS sensors above 100°C – Hygienic Connections only

Sizes 25S, 40S, 50S and 80S sensors with hygienic connections may be exposed to temperatures above 100°C up to a maximum of 130°C for a maximum of 2 hours (e.g. for steam cleaning purposes). The maximum temperature shock permitted either from cold to hot or from hot to cold is 110°C.

E.g. A meter measuring a product at 20°C can be immediately steam cleaned at 130°C, but a meter measuring a product at 5°C can only be immediately steam cleaned at 115°C. Conversely, after steam cleaning at 130°C the minimum allowed temperature of the product introduced immediately afterwards is 20°C.

Operation outside of these guidelines may cause shifts in the mass flow and density calibration. Repeated shocking may also cause premature failure of the meter.

1.2.7 Heating and insulation

There are several methods to heat the meter. In most cases heating is unnecessary as the meter is designed as such that very little heat is lost or gained through the outer cylinder.

Insulation

Where insulation is required a variety of materials may be used to insulate the meter. Care must be taken not to insulate the meter above the halfway mark of the electronics support post as shown in the sketch.

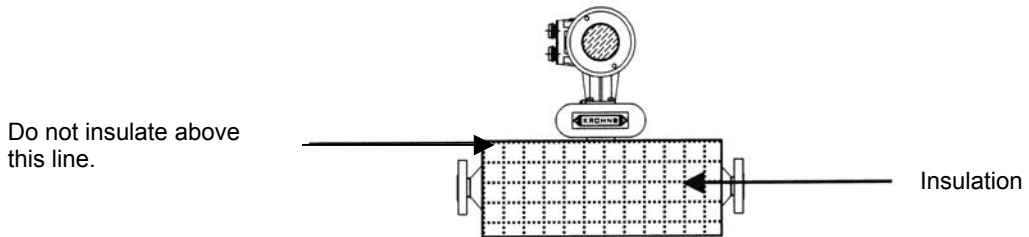

Electrical Heating

Electrical tape heating may be used. Care should be taken to only heat the sections where the best effect will be achieved. Do not heat above the converter mount centre line as shown above. The following guidelines must be observed.

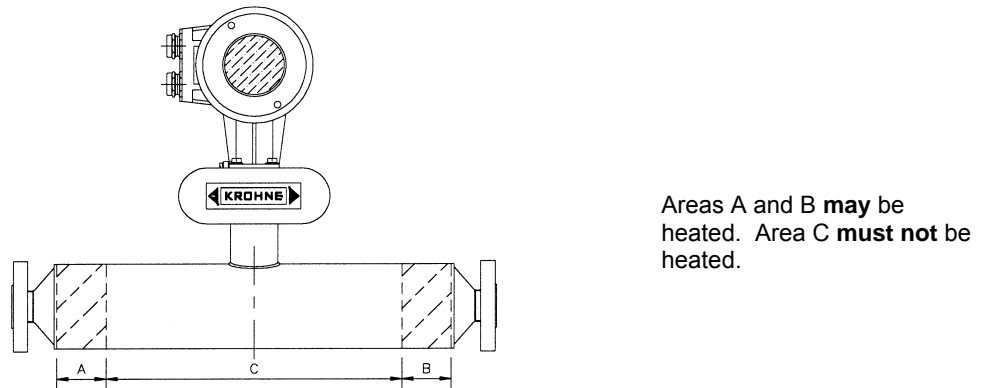

When insulating please observe guidelines as per insulation section.

Size	DIM A and B	
	Titanium	Hastelloy + SS 318
10	50	-
15	65	65
25	120	75
40	150	150
50	200	125
80	410	225

Liquid / Steam heating jacket

The meter can be supplied with a heating jacket. This jacket is designed to minimise the differential stress across the meter where differences in temperature between outer cylinder and measuring tube exist.

The connections to the heating jacket are NPT or Ermeto sockets.

It is recommended that reinforced flexible hoses be used to connect the heating jacket to the heat source.

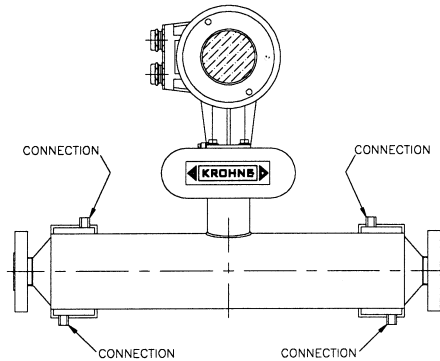

Important:

Always heat jacket to working temperature before flowing product in measuring tube.

It is important to avoid the use in the heating jackets of fluids which cause crevice corrosion.

Regarding jacket materials. Although all the jacket materials are 316L, the outer cylinders are 304L (Optional 316L).

Connections should be made to ensure all air can be vented on liquid systems and all condensate can be drained on steam systems.



Note :

Max heating medium pressure and temperature for heating jackets is 10 bar at 150°C or 145 psig at 300°F for titanium measuring tubes and 10 bar at 100°C or 145 psig at 210 °F for Hastelloy and Stainless Steel measuring tubes.

Heating Times

The following graphs are provided as a guide only. Heating times were calculated and tested using the following conditions:

- Ambient temperature 25°C or 80°F
- Meter insulated.

The Titanium meters were heated using a steam temperature of 150°C or 300°F and the Hastelloy and Stainless Steel meters using a temperature of 100°C or 210°F.

Heating times may vary depending on the quality of insulation (if any), ambient temperature and temperature of the heating medium. Once meter has been heated to a temperature where the product will not solidify, product may be introduced if required. This will bring the meter to operating temperature sooner.



Note:

The maximum heating temperature for a Titanium meter is 150°C or 300°F.
The maximum heating temperature for Hastelloy or SS meters is 100°C or 210°F.

If these temperatures are exceeded, the meter will be damaged.

KROHNE accepts no responsibility if this happens.

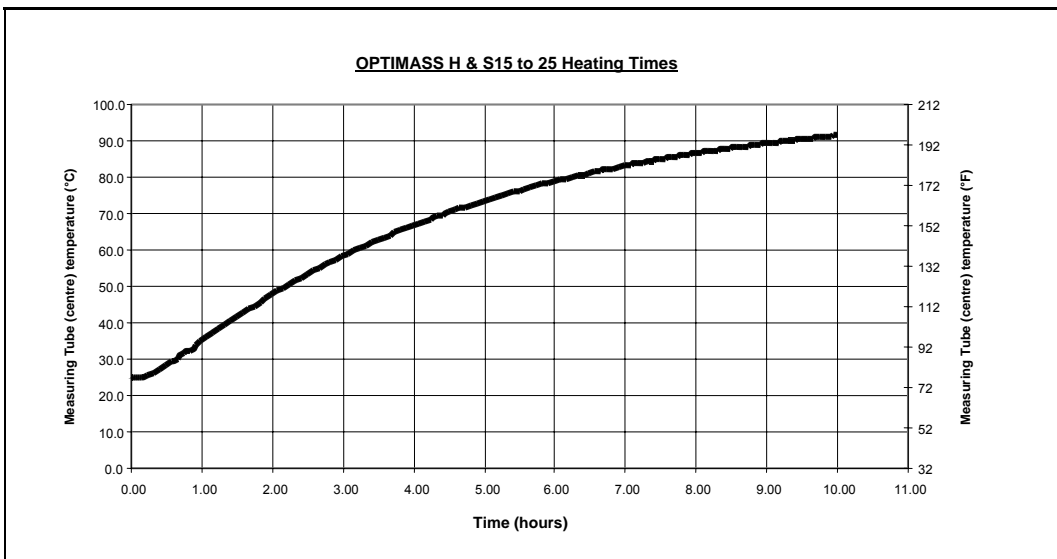
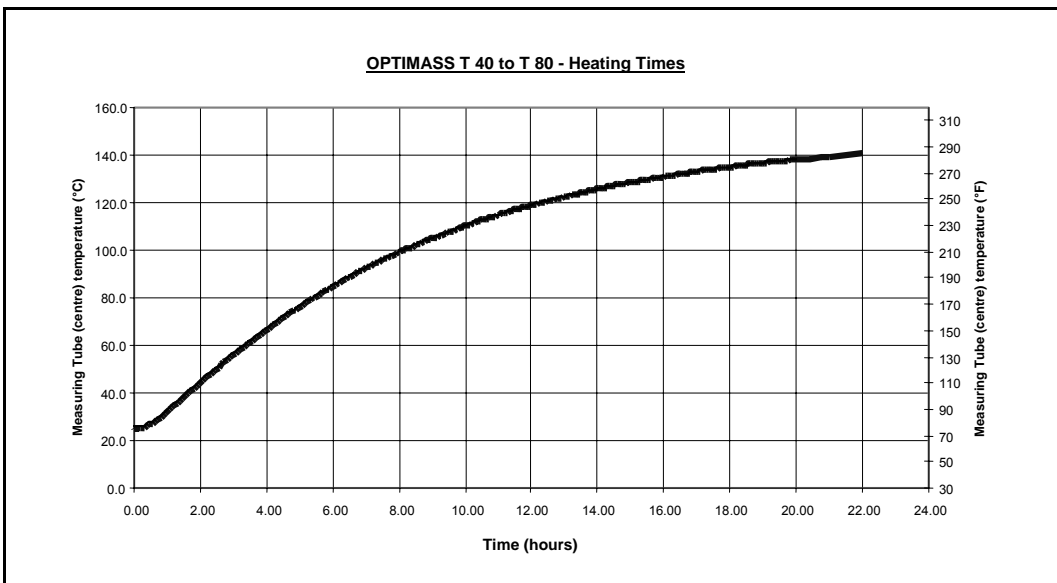
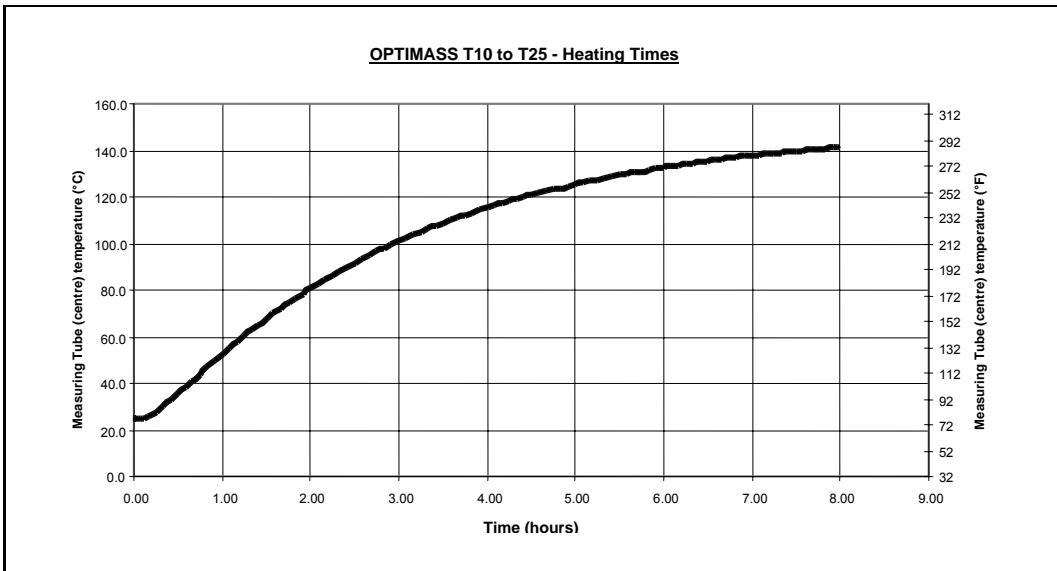

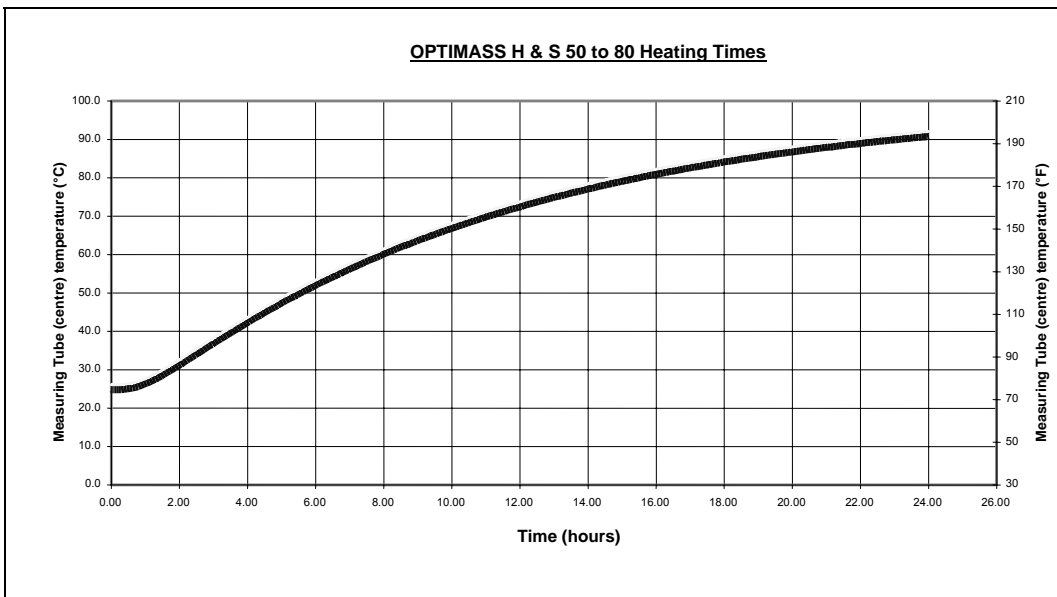
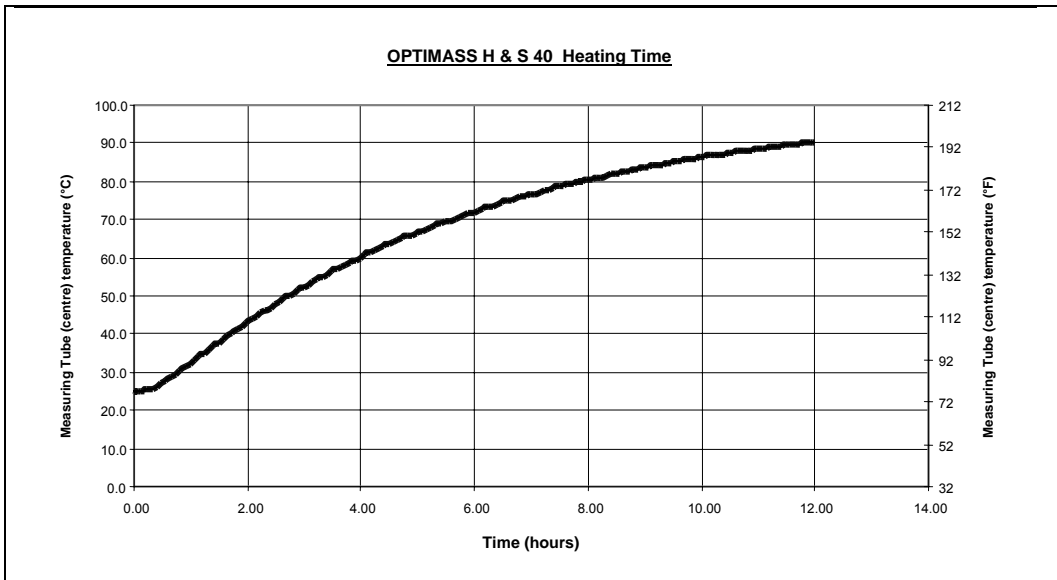

Cooling

Please consult KROHNE if cooling medium is to be used in the heating jacket.

1.2.8 Purge Port Meters and Burst Disk Meters

Purge Port Options

If the purge port option was selected at time of order, then your meter will be fitted with ½" NPT female connections – these will be clearly identified. These connections are sealed with NPT plugs and PTFE tape.



Important:

Do not remove these plugs.

The meter is factory sealed with a dry nitrogen gas fill and any ingress of moisture will damage the meter. The plugs should only be removed to purge the inside of the meter case of any product if it is suspected that the primary measuring tube has failed. This must only be done after the meter has been depressurised and removed from service. This should be done as soon as possible after failure is suspected (less than 3 days)

Burst Disk meters (Meters up to size 25 only)

OPTIMASS 7000 meters that have been ordered with a bursting (rupture) disk will be so fitted. This is fitted when the operating pressure of the measuring tube exceeds the design pressure of the secondary containment. The disk failure pressure is 20bar @ 20°C.



Important:

The burst disk is suitable for the designed application according to the process conditions and flow rates as per original order. If conditions alter, consult KROHNE for further advice regarding suitability of disk fitted.

If the product is in any way hazardous, it is strongly recommended that an exhaust tube is connected to the NPT male thread of the burst disk so that the discharge can be piped to a safe area. This tube should be large enough that pressure cannot build up in the meter case.

Ensure arrow on burst disk is pointing away from meter.

1.2.9 Technical Data

Nominal Flow Rates

	06	10	15	25	40	50	80
Kg/h	950	2,700	11,250	34,500	91,500	180,000	430,000
Lbs/min	35	100	400	1,250	3,350	6,600	15,800

Maximum flow rate

Typically 130 % of the nominal flow rate for the sensor size depending on application.

Minimum flow rate

Depending on measuring error required.

Tube materials:

- Titanium Gr. 9,
- Hastelloy C22 and
- SS 318.

The meter size has a prefix T, H, or S indicating the tube material.

Secondary pressure containment

- All 70 Series meters have secondary containment rated to 40 bar or 580 psi.
- An optional 63 bar or 914 psi is available.

Materials of construction

- Flanges: SS 316 L
- Spigots and outer cylinder: SS 304 L optional SS 316 L
- Front end housing and post: SS 316 L
- Converter housing: Epoxy coated aluminium

1.2.10 Weights & Dimensions

Weights

Weight of OPTIMASS 7000 sensor fitted with a typical standard flange in kg (lbs)

Size	06	10	15	25	40	50	80
Kg	16	20	23	35	80	145	260
lbs	35	44	51	77	176	319	572

Flanged versions

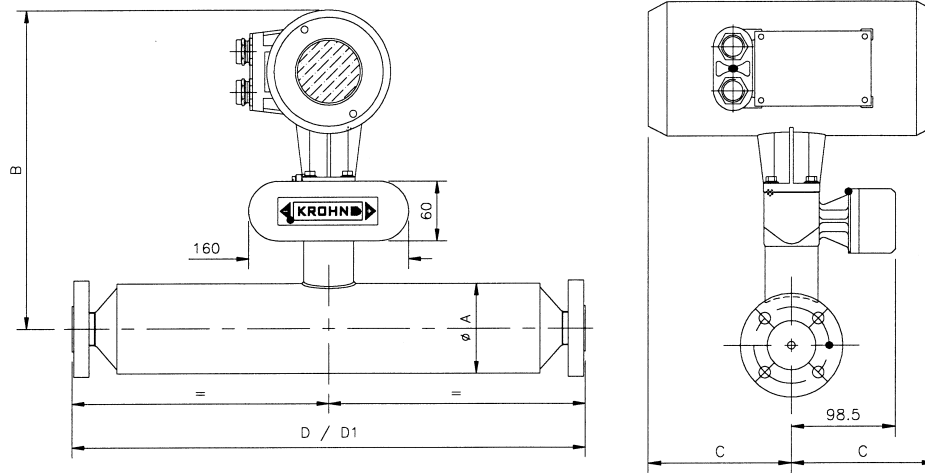

Dimensions

	Meter Size	ø A	B	C std	C Ex	D for std Flanges	D1 for ANSI 600# flg. & tongue/groove
mm	06	102	312	104	120	420±2	428±2
	10	102	312	104	120	510±2	518±2
	15	102	312	104	120	548±2	556±2
	25	115	319	104	120	700±2	708±2
	40	170	346	104	120	925±2	933±2
	50	220	371	104	120	1101±2	1109±2
inches	06	4.0	12.3	4.1	4.7	16.5±0.08	16.9±0.08
	10	4.0	12.3	4.1	4.7	20.1±0.08	20.4±0.08
	15	4.0	12.3	4.1	4.7	21.6±0.08	21.9±0.08
	25	4.5	12.6	4.1	4.7	27.6±0.08	27.9±0.08
	40	6.7	13.6	4.1	4.7	36.4±0.08	36.7±0.08
	50	8.7	14.6	4.1	4.7	43.3±0.08	43.7±0.08
	80	10.8	15.7	4.1	4.7	57.5±0.08	57.8±0.08

Hygienic Versions

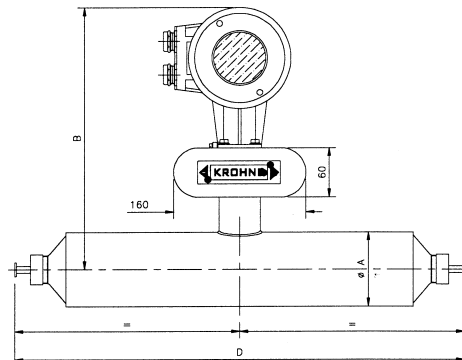

As for flanged meters except for dimension D opposite

Meter	connection size	Connection type	Connection standard	D in mm	D in inches
6	DN10	all welded	din 32676	484	19.1
	1/2"	all welded	tri-clover	480	18.9
10	DN10	all welded	DIN 11864	528	20.8
	DN10	all welded	DIN 32676	564	22.2
	1/2"	all welded	Tri-clover	558	22.0
	DN10	adaptor	DIN 11851	596	23.5
	DN10	adaptor	DIN 32676	590	23.2
	1/2"	adaptor	Tri-clover	597	23.5
	10A	adaptor	IDF Clamp	607	23.9
15	DN15	all welded	DIN 11864	566	22.3
	DN15	all welded	DIN 32676	602	23.7
	3/4"	all welded	Tri-clover	596	23.5
	DN15	adaptor	DIN 11851	634	25.0
	DN15	adaptor	DIN 32676	628	24.7
	3/4"	adaptor	Tri-clover	635	25.0
	15A	adaptor	IDF Clamp	626	24.6
	1"	adaptor	SMS	652	25.7
	1"	adaptor	IDF/ISS	664	26.1
	1"	adaptor	ISO 2852	665	26.2
	1"	adaptor	RJT	676	26.6
25	DN25	all welded	DIN 11864	718	28.3
	DN25	all welded	DIN 32676	761	30.0
	1.5"	all welded	Tri-clover	816	32.1
	1.5"	all welded	ISO 2852	816	32.1
	DN25	adaptor	DIN 11851	802	31.6
	DN25	adaptor	DIN 32676	787	31.0
	1.5"	adaptor	Tri-clover	855	33.7
	1.5"	adaptor	ISO 2852	855	33.7
	1.5"	adaptor	SMS	852	33.5
	1.5"	adaptor	IDF/ISS	854	33.6
	1.5"	adaptor	RJT	866	34.1
40	DN40	all welded	DIN 11864	948	37.3
	DN40	all welded	DIN 32676	986	38.8
	2"	all welded	Tri-clover	1043	41.1
	2"	all welded	ISO 2852	1043	41.1
	DN40	adaptor	DIN 11851	1040	40.9
	DN40	adaptor	DIN 32676	1017	40.0
	2"	adaptor	Tri-clover	1077	42.4
	2"	adaptor	ISO 2852	1077	42.4
	2"	adaptor	SMS	1074	42.3
	2"	adaptor	IDF/ISS	1076	42.4
	2"	adaptor	RJT	1088	42.8
50	DN50	all welded	DIN 11864	1124	44.3
	DN50	all welded	DIN 32676	1168	46.0
	3"	all welded	Tri-clover	1305	51.4
	3"	all welded	ISO 2852	1305	51.4
	DN50	adaptor	DIN 11851	1220	48.0
	DN50	adaptor	DIN 32676	1193	47.0
	3"	adaptor	Tri-clover	1355	53.3
	3"	adaptor	ISO 2852	1355	53.3
	3"	adaptor	SMS	1360	53.5
	3"	adaptor	IDF/ISS	1354	53.3
	3"	adaptor	RJT	1366	53.8
80	DN80	all welded	DIN 11864	1538	60.6
	DN80	all welded	DIN 32676	1584	62.4
	3"	all welded	Tri-clover	1527	60.1
	3"	all welded	ISO 2852	1527	60.1
	DN80	adaptor	DIN 11851	1658	65.3

Heating Jacket

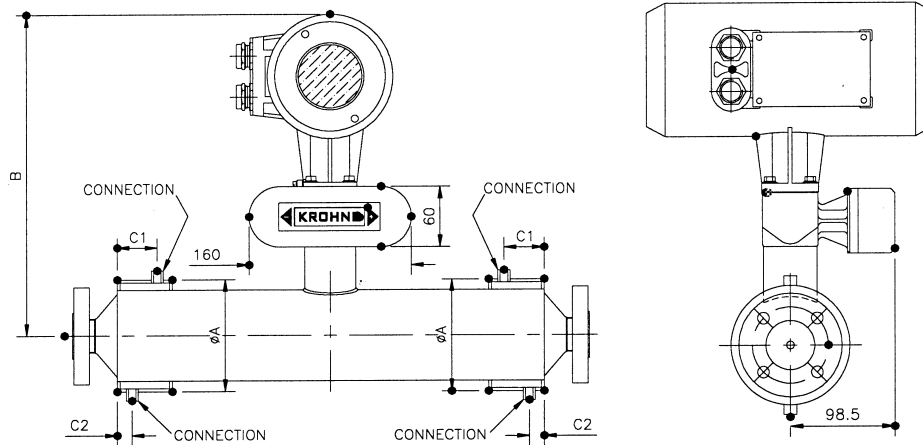

Dimensions

HJ	Meter Size	Connection Size	ø A	B	Titanium		Hastelloy	
					C 1	C 2	C 1	C 2
mm	10	1/2"(12 mm)	115±1	312	36±1	20		
	15	1/2"(12 mm)	115±1	312	51±1	20	51±1	20
	25	1/2"(12 mm)	142±1	319	100±1	20	55±1	20
	40	1/2"(12 mm)	206±1	346	130±1	20	130±1	20
	50	1/2"(12 mm)	254±1	371	180±1	20	105±1	20
	80	1"(25 mm)	305±1	398	385±2	26±1	200±2	26±1
inches	10	1/2"(12 mm)	4.5±0.04	12.3	1.4±0.04	0.8		0.8
	15	1/2"(12 mm)	4.5±0.04	12.3	2.0±0.04	0.8	2.0±0.04	0.8
	25	1/2"(12 mm)	5.6±0.04	12.6	3.9±0.04	0.8	2.2±0.04	0.8
	40	1/2"(12 mm)	8.1±0.04	13.6	5.1±0.04	0.8	5.1±0.04	0.8
	50	1/2"(12 mm)	10.0±0.04	14.6	7.1±0.04	0.8	4.1±0.04	0.8
	80	1"(25 mm)	12.0±0.04	15.7	15.2±0.08	1.0±0.04	3.9±0.08	1.0±0.04

Purge Ports (optional)

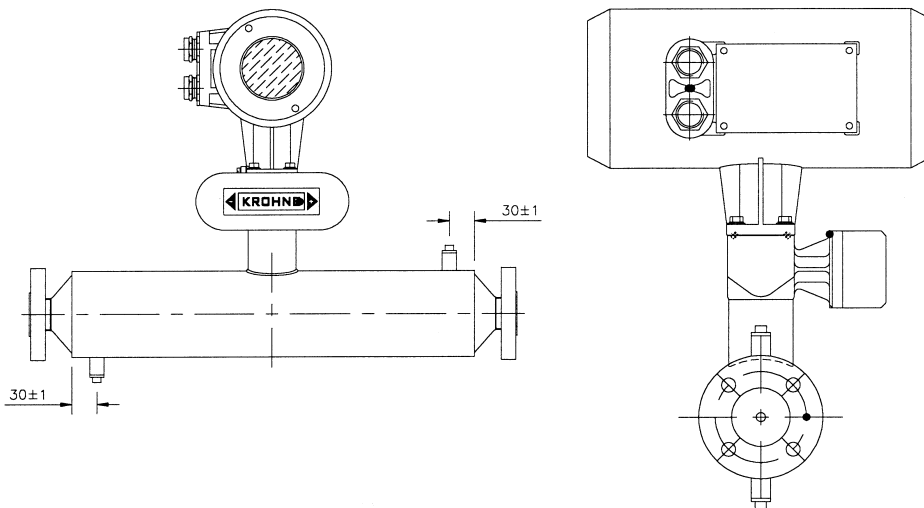

Note: For all other dimensions see compact version

1.3 OPTIMASS 3000 (7100) Single Z Shaped Tube Meter

1.3.1 Specific Installation Guidelines

When installing, please observe the following:

- Four holes are provided in the base plate and all four should always be used.
- The plastic inserts in the base plate mounting holes are important to ensure a rigid and stable connection to the mounting structure.
- It is important to mount on a firm and rigid structure to obtain a stable zero condition.
- The following guidelines are provided to assist the installer to select the best option:

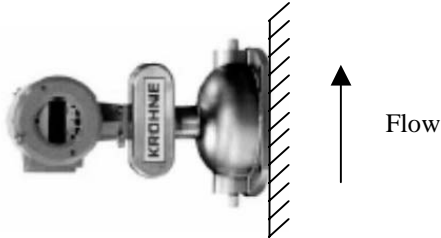

Vertical mount is possible.



Horizontal mount is possible.



Take care to avoid gas build up in top half of tube bends.

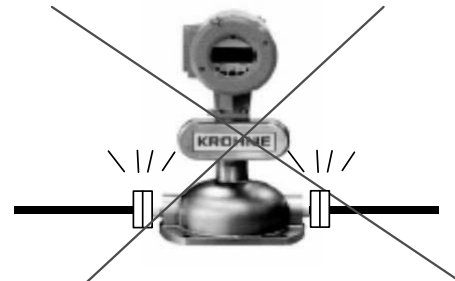

Do not suspend from flanges alone. Base must always be supported.

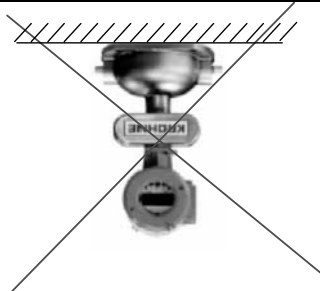

Do not install upside down

Flanged and Tri-clamp Meters

When installing these meters ensure that the pipework is supported behind the process flange, so that no unnecessary stress is applied to the meter flanges.

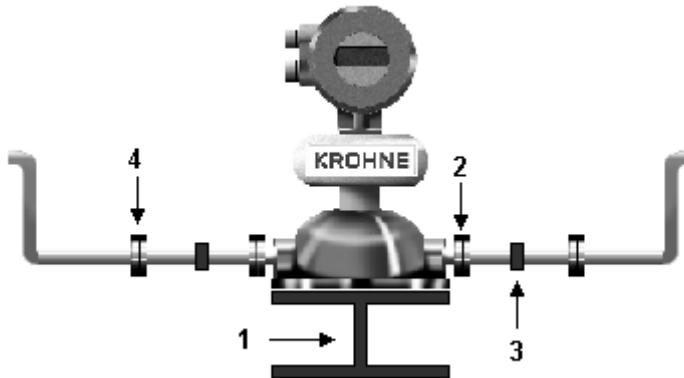

1. First fix meter to firm support
2. Carefully align process flanges and connect
3. Support process pipe close to flanges – do not pull pipe with clamps
4. Make final process connections – if no connections in this area, try to have some flexibility in process pipe



Note :

Please note that gas bubbles can also accumulate between flange and measuring tube due to the step change, mount vertically to avoid this.

1.3.2 Ambient / Process temperatures

The specified and approved ambient and process temperatures must be observed.

		SS316L or HC22	
		°C	°F
Process		-40 .. +150	-40 .. +300
Ambient	Compact	-40 .. +55	-40 .. +130
	Remote	-40 .. +60	-40 .. +140



Note:

Where meters are mounted in direct sunlight, it is recommended to install a sunshade. This is particularly important in countries with high ambient temperatures.

1.3.3 Pressure Equipment Directive (PED) requirements.

To comply with the requirements of the PED in Europe, the following information is provided to assist the plant engineer in installing the meter.

Measuring tube:	S	Stainless SS 316 L
	H	Hastelloy C22

The outer cylinder (Secondary Pressure containment) 304 / 304L is dual certified and with “O” rings in pairs of Viton and hydrogenated nitrile. (Optional outer cylinder of 316/316L).

Wiring feedthrough is made of Epoxy.

Flanges all 316 / 316 L dual certified.

Optional heating jacket 316 / 316L.



Note :

Outer cylinder is in contact with heating medium.

1.3.4 Secondary Pressure containment

The OPTIMASS 3000 (7100) meters are supplied with secondary pressure containment as standard.

Allowable maximum secondary containment pressures are 30 bar at 20°C or 435 psig at 70°F, and is de-rated as follows :

20 °C	50°C	100°C	150°C
30 bar	28.5 bar	26.1 bar	24 bar

The de-rating is based on the reduction of material strength with temperature for 316L (W No. 1.4404) material from DIN 17456.

Heating jacket is rated to 10 bar at 150°C or 145 psig at 300°F.

If heating jacket fitted, secondary containment is limited to 10 bar at 150°C or 145 psig at 300°F. This is because the jacket is fitted inside of the secondary containment dome.

If meter operating pressure is higher than the secondary containment allowable pressure then a relief or bursting disk option (fitted in the dome) **MUST** be ordered. In this case the meter data plate is stamped with maximum pressure rating (at maximum operating temperature) of the connection or the primary tube (whichever is the lower).



Note:

Burst disc options are not available in combination with a heating jacket.

1.3.5 Pressure de-rating

Meter data plates are stamped with maximum pressure rating (at max. operating temperature) of connection, primary tube or secondary pressure containment (whichever is the lower). Higher pressures may be possible at lower temperatures.

Stainless Steel tubes:

150 bar at 80°C or 2175 psi at 175°F
50 bar at 150°C or 725 psi at 300°F

Hastelloy C22 tubes:

150 bar at 150°C or 2175 psi at 300°F
(no de-rating required)

Pressure Derating

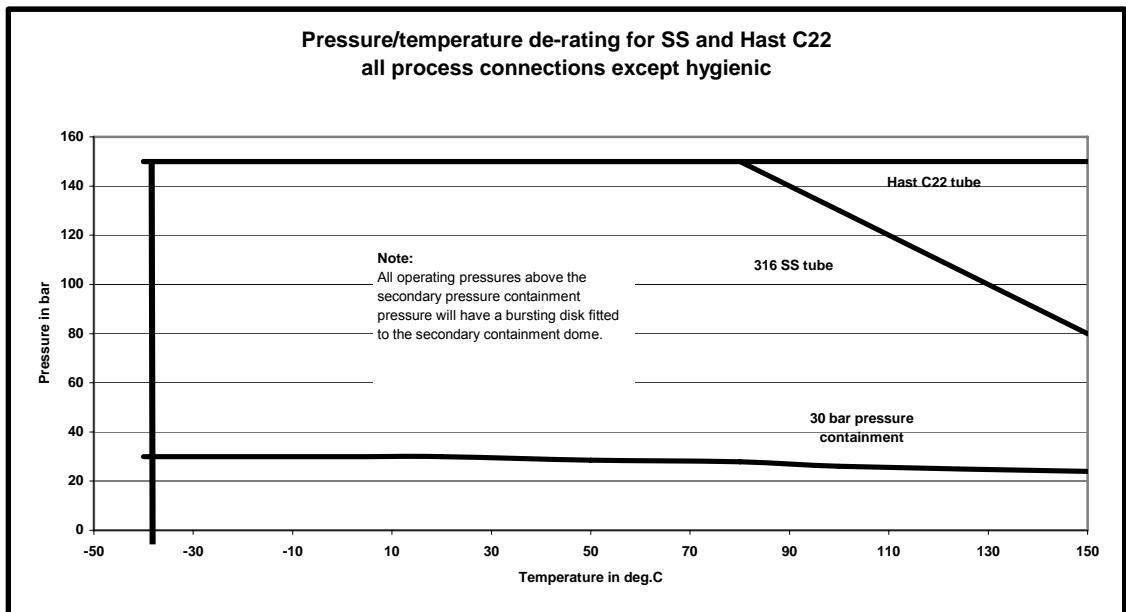

1.3.6 Heating and insulation

All secondary containment and heated jacket parts are 316L, except the 1/4" NPT Female connections, which are 316.

Max heating medium pressure and temperature is 10 bar at 150°C or 145 psig at 300°F.

The max secondary containment pressure on the OPTIMASS 3000 (7100) when fitted with a heating jacket is 10 bar at 150°C or 145 psig at 300°F.

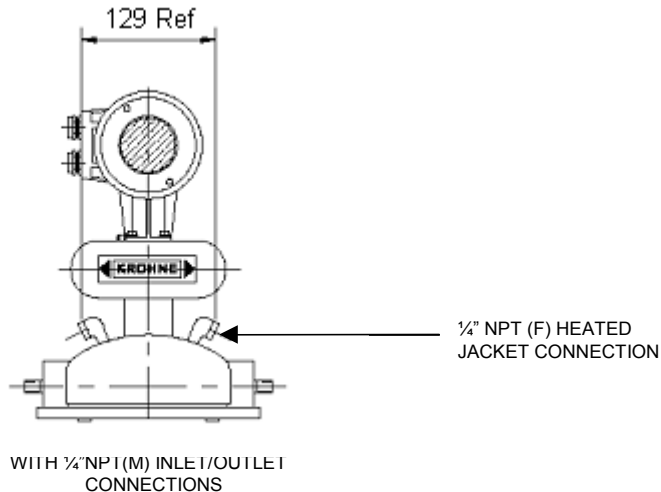

1.3.7 Purge Port Meters and Burst Disk Meters

Purge Port Options

If the purge port option was selected at time of order, then your meter will be fitted with 1/4" NPT female connections – these will be clearly identified. These connections are sealed with NPT plugs and PTFE tape.



Important:

Do not remove these plugs.

The meter is factory sealed with a dry nitrogen gas fill and any ingress of moisture will damage the meter. The plugs should only be removed to purge the inside of the meter case of any product if it is suspected that the primary measuring tube has failed. This must only be done after the meter has been depressurised and removed from service. This should be done as soon as possible after failure is suspected (less than 3 days)

Burst Disk meters

OPTIMASS 3000 (7100) meters that have been ordered with a bursting (rupture) disk will be so fitted. This is fitted when the operating pressure of the measuring tube exceeds the design pressure of the secondary containment. The disk failure pressure is 20bar @ 20°C.



Important:

The burst disk is suitable for the designed application according to the process conditions and flow rates as per original order. If conditions alter, consult KROHNE for further advice regarding suitability of disk fitted.

If the product is in any way hazardous, it is strongly recommended that an exhaust tube is connected to the NPT male thread of the burst disk so that the discharge can be piped to a safe area. This tube should be large enough that pressure cannot build up in the meter case.

Ensure arrow on burst disk is pointing away from meter.

1.3.8 Technical Data

Nominal Flow Rates

	01	03	04
Kg/h	15	100	350
Lbs/min	0.5	3.5	12.5

Maximum flow rate

Typically 130 % of the nominal flow rate for the sensor size depending on application.

Minimum flow rate

Depending on measuring error required.

Tube materials:

- S 316L
- Hastelloy C22

The meter size has a prefix S or H indicating the tube material.

Secondary pressure containment

- All OPTIMASS 3000 (7100) Series meters have secondary containment rated to 30 bar or 435 psi.

Materials of construction

- Connections: SS 316 L or HC22
- Secondary Containment: SS 316 L
- Front end housing and post: SS 316 L
- Converter housing: Epoxy coated aluminium

1.3.9 Weights & Dimensions

Weights

Weight of OPTIMASS 3000 (7100) sensor fitted with a typical standard connection in kg (lbs)

Size	01	03	04
Kg	12	12	12
lbs	26.4	26.4	26.4

Standard Connections

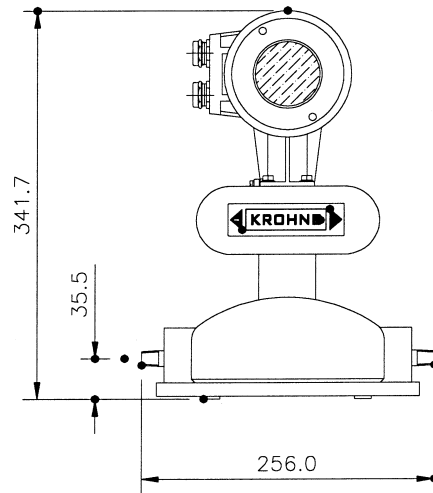

WITH 1/4" NPT(M) CONNECTIONS

Flanged and Hygienic Connections

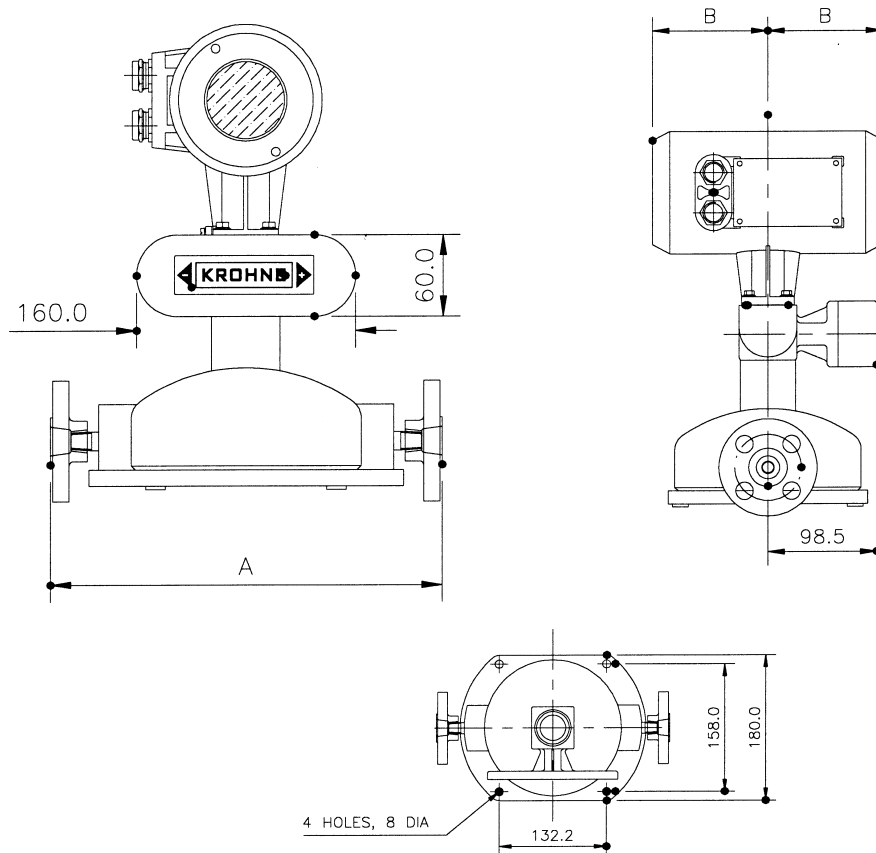

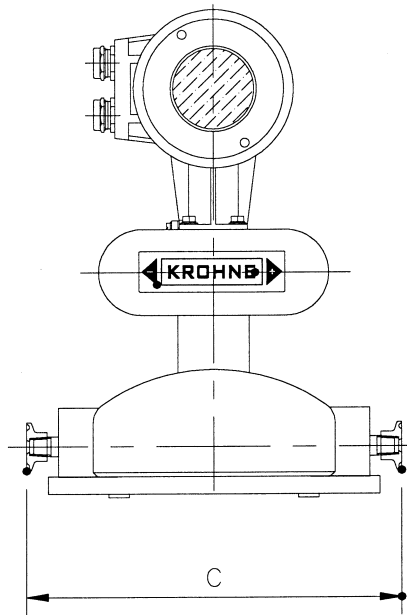

Dimensions

7100	Flange Size	ø A	B std	B Ex	C
mm	None	256	104	120	N/A
	ANSI 150	286±2	104	120	N/A
	ANSI 300	286±2	104	120	N/A
	ANSI 600	295±2	104	120	N/A
	DIN15 PN40	286±2	104	120	N/A
	DIN15 PN63	295±2	104	120	N/A
	DIN10 DIN 32676	N/A	104	120	260
	1/2" TRI CLOVER	N/A	104	120	261.6
inches	None	10.1	4.1	4.7	N/A
	ANSI 150	11.3	4.1	4.7	N/A
	ANSI 300	11.3	4.1	4.7	N/A
	ANSI 600	11.6	4.1	4.7	N/A
	DIN15 PN40	11.3	4.1	4.7	N/A
	DIN15 PN63	11.6	4.1	4.7	N/A
	DIN10 DIN 32676	N/A	4.1	4.7	10.2
	1/2" TRI CLOVER	N/A	4.1	4.7	10.3

1.4 OPTIMASS 8000 / 9000 Meter with Twin U Measuring Tubes

1.4.1 Specific Installation Guidelines

- Tighten flange bolts evenly.
- Do not stress the sensor mechanically. Clamp and support the connecting pipework accordingly.
- It is permissible to support the weight of the meter on the square body.
- Cavitation and Mechanical vibration should be avoided.
- Use of standard pipework reducers at the flange is allowed. Avoid extreme changes in pipe size (step changes).
- The use of flexible hoses directly at the meter is not permitted.
- Installation below 0°C - mount vertically, or horizontally with converter up to prevent freezing or condensation in housing.

Horizontal Mounting:

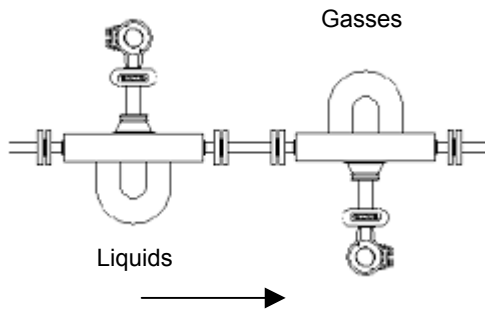

For liquids, measuring tube downwards so that no gas collects in tube if no-flow.

For gasses, measuring tube upwards, so no liquids can collect if no-flow.

1.4.2 Ambient / Process temperatures

The specified and approved ambient and process temperatures must be observed.

		8000		9000	
		°C	°F	°C	°F
Process	Safe Area	-180 .. +230	-292 .. +446	0 .. +350	0 .. 662
	ATEX/FM/CSA - Compact	-40 .. +190	-40 .. +374		
	ATEX/FM/CSA - Remote	-40 .. +230	-40 .. +446		
Ambient	Compact	-40 .. +55	-40 .. +130	-	-
	Remote	-40 .. +60	-40 .. +140	-40 .. +60	-40 .. +140



Note:

Where meters are mounted in direct sunlight, it is recommended to install a sunshade. This is particularly important in countries with high ambient temperatures.

The maximum differential temperature between the process and ambient temperature without insulation is 80°C or 176°F.

1.4.3 Pressure Equipment Directive (PED) requirements.

To comply with the requirements of the PED in Europe, the following information is provided to assist the plant engineer in installing the meter.

Measuring tube:	Stainless SS 316L Hastelloy C22	Sealing Faces:	Stainless SS 316L Hastelloy C22
Flanges:	SS316L		
Casing:	Stainless Steel 316 Typical burst pressure of case is in excess of 50 bar @ 20°C Not PED approved		

Insulation is strongly recommended above 100°C

For insulated meters without heating jackets, repeated heating or cooling at rates > 30°C per hour should be avoided to increase operational lifespan of meter.

1.4.4 Secondary Pressure containment

The OPTIMASS 8000/9000 series sensors do not have certified secondary containment.

If the user suspects that the primary tube has failed, the unit must be depressurised and removed from service as soon as possible.

1.4.5 Pressure de-rating

Meter data plates are stamped with maximum pressure rating (at max. operating temperature) of connection, primary tube or secondary pressure containment (whichever is the lower). Higher pressures may be possible at lower temperatures.

Measuring Tubes:

	Process Temperature Maximum 150 °C / 300 °F	Process Temperature Maximum 230 °C / 440 °F	Process Temperature Maximum 350 °C / 660 °F (9000 series only)
Meter size	barg psig	barg psig	barg psig
15	210 3045	185 2680	160 2320
25	165 2390	145 2100	125 1810
40	140 2030	120 1740	105 1520
80	125 1810	110 1595	95 1375
100	85 1230	75 1085	65 940

Flanges:

DIN flanges to EN1092-1. Note also pressure / temperature limits for measuring tubes above.

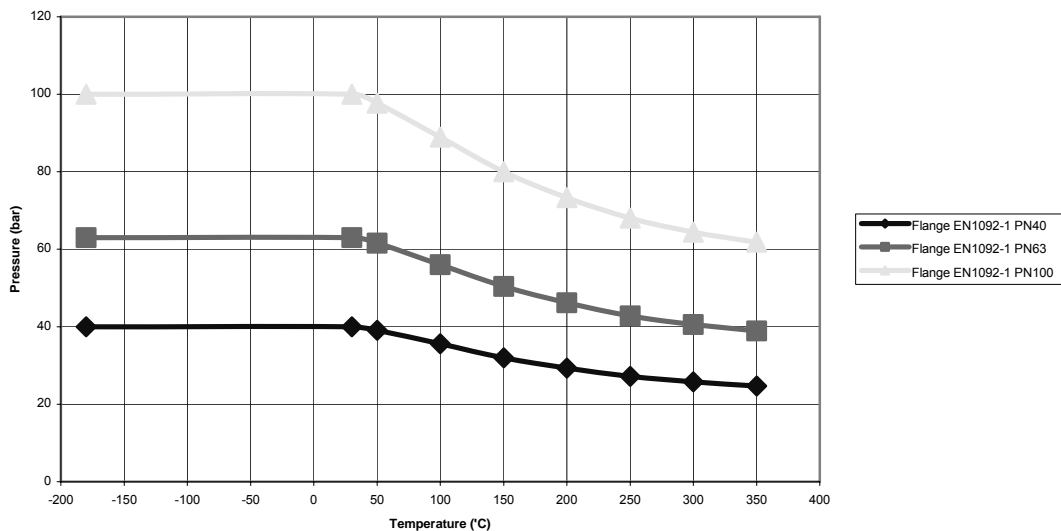

ANSI flanges to ASME B16.5. Note also pressure / temperature limits for measuring tubes above.

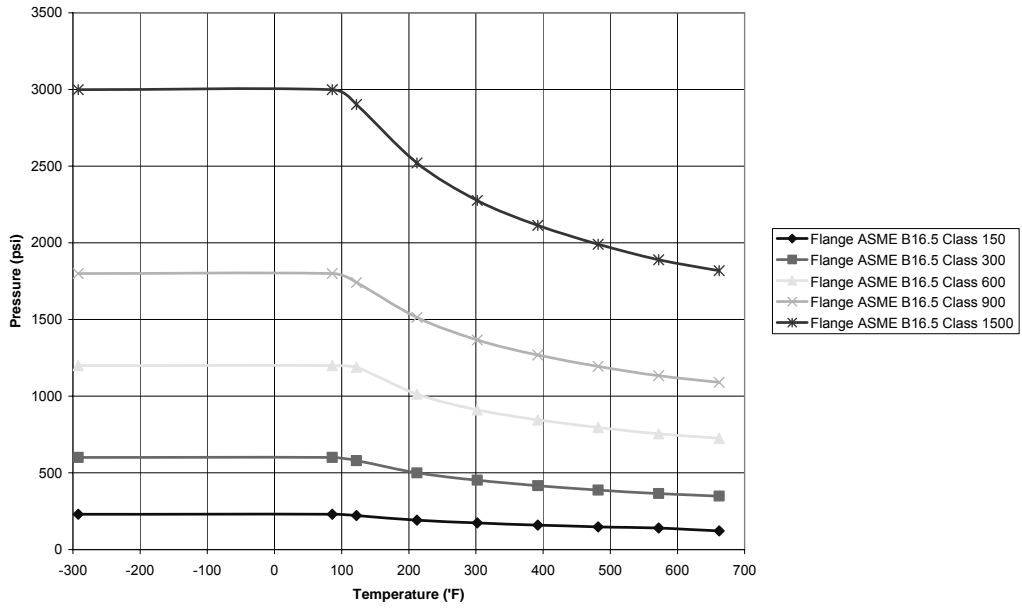

JIS flanges to 2220 B. Note also pressure / temperature limits for measuring tubes above.

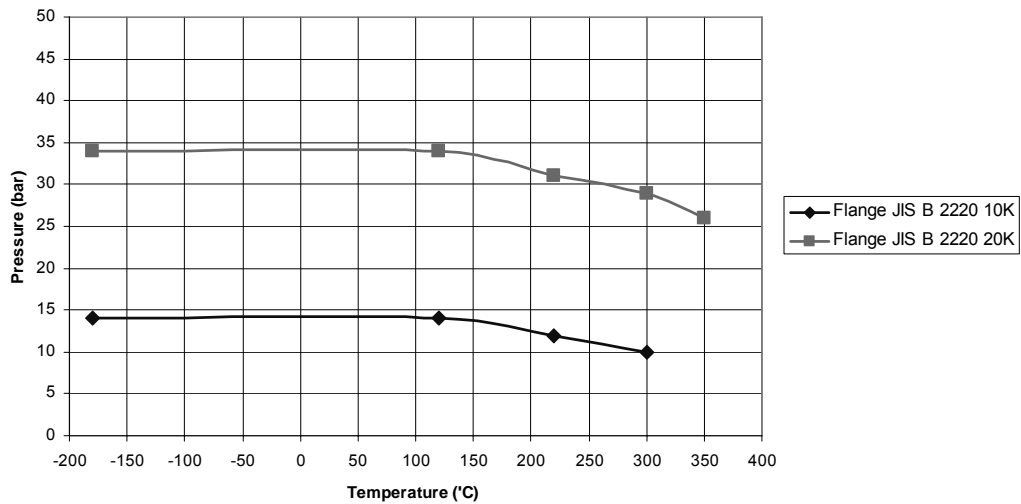

Hygienic and sanitary connections (all sizes)

Maximum pressure: 10 barg at 150°C or 145 psig at 302°F

Maximum pipe work forces

Forces exerted on the meter from the process pipe are not permitted. Mechanical installation should be designed to prevent such forces.

1.4.6 Hygienic Applications

The OPTIMASS 8000/9000 series is available with a variety of hygienic process connectors. When using / installing meters with hygienic process connectors, care should be taken to ensure the meter is well supported / clamped, as the meters are heavy and could injure when disconnected from the adjacent pipe work.

The recommended method of installation is to mount the meter against a support / wall with the body of the meter supported / clamped. The process pipe work can then be supported off the meter.

The meter is too heavy to be supported from the thin walled piping usually associated with the hygienic industry.

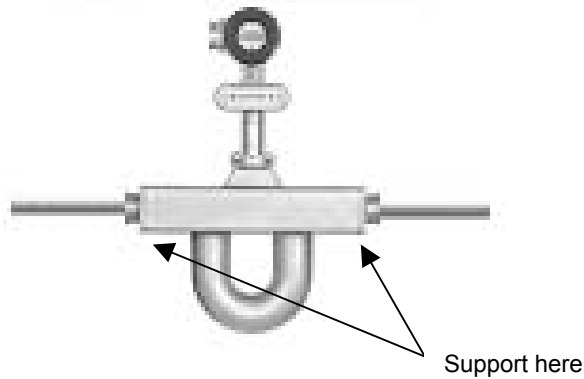

Meter supported from its body

Installation lengths

For installation lengths, please see section 1.4.10

Please check with KROHNE if you are unsure of the installation length. Many meters are built to customer requirements / specifications especially where special hygienic process connectors have been adapted to the meter. As these are normally non-standard, the installation length will not be given in the technical data.

It is also recommended that the seals be replaced regularly to maintain the hygienic integrity of the connection.

Hygienic Connection Materials

Material: SS 316L

Unless specifically requested, internal surfaces are not polished and no warranty is made as to the surface finish. If option of EHEDG, ASME Bio-Processing or 3A approvals was selected at time of order, all product contact surfaces are polished 0.8 micrometer Ra (Ra 32) finish or better. Only available for hygienic connections.

1.4.7 Heating and insulation

Insulation

OPTIMASS 8000

Where insulation is required a variety of materials may be used to insulate the meter. Care must be taken not to insulate the meter above the halfway mark of the electronics support post as shown in the sketch.

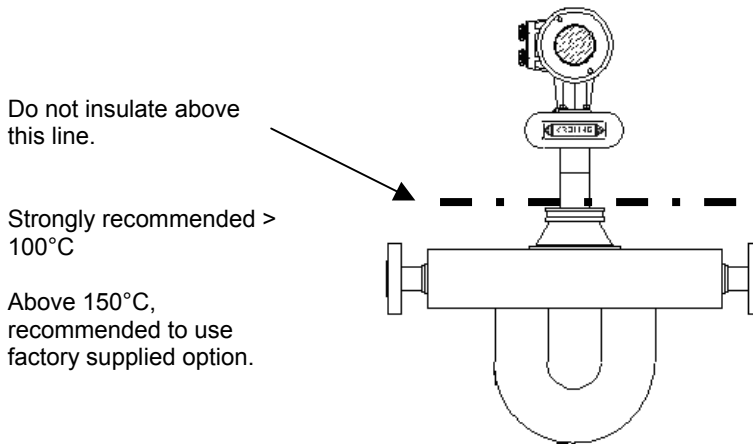

For insulated meters without heating jackets, repeated heating or cooling at rates $> 30^{\circ}\text{C}$ per hour should be avoided to increase operational lifespan of meter

OPTIMASS 9000 - The OPTIMASS 9000 will always be supplied with factory fitted insulation or heating option

Electrical Heating

Electrical tape heating may be used. Do not heat above line as shown above.

Max heating temperature is 230°C or 446°F for OPTIMASS 8000 and 350°C or 662°F for OPTIMASS 9000.

Observe Ex limits.

Liquid / Steam heating jacket

The meter can be supplied with a heating jacket.

This jacket is designed to minimise the differential stress across the meter where differences in temperature between outer cylinder and measuring tube exist.

The connections to the heating jacket are DN15 PN40, ANSI $\frac{1}{2}$ " 150lbs or JIS 10K 15A

Protection is IP54. Install protective roof if necessary.



Important:

Always heat jacket to working temperature before flowing product in measuring tube.

Repeated heating or cooling at rates $> 30^{\circ}\text{C}$ per hour should be avoided to increase operational lifespan of meter.



Note :

Max heating medium temperature is 230°C or 446°F for OPTIMASS 8000 and 350°C or 662°F for OPTIMASS 9000. Observe Ex limits also. Maximum heating medium pressure limited by jacket connections. Refer to de-rating curves as per section 1.4.5.

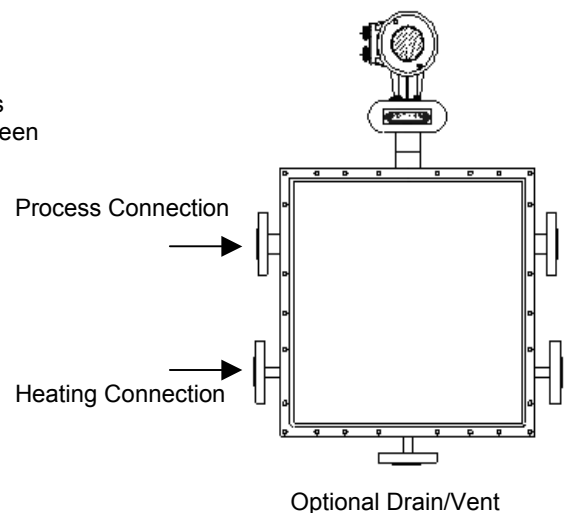

1.4.8 Purge Port Meters and Burst Disk Meters

Purge Port Options

If the purge port option was selected at time of order, then your meter will be fitted with 1/4" NPT female connections – these will be clearly identified. These connections are sealed with NPT plugs and PTFE tape.



Important:

Do not remove these plugs.

The meter is factory sealed with a dry nitrogen gas fill and any ingress of moisture will damage the meter. The plugs should only be removed to purge the inside of the meter case of any product if it is suspected that the primary measuring tube has failed. This must only be done after the meter has been depressurised and removed from service. This should be done as soon as possible after failure is suspected (less than 3 days)

Burst Disk meters

OPTIMASS 8000/9000 meters that have been ordered with a bursting (rupture) disk will be so fitted. This is fitted when the operating pressure of the measuring tube exceeds the design pressure of the secondary containment. The disk failure pressure is 20bar @ 20°C.



Important:

The burst disk is suitable for the designed application according to the process conditions and flow rates as per original order. If conditions alter, consult KROHNE for further advice regarding suitability of disk fitted.

If the product is in any way hazardous, it is strongly recommended that an exhaust tube is connected to the 3/4" NPT male thread of the burst disk so that the discharge can be piped to a safe area. This tube should be large enough that pressure cannot build up in the meter case.

Ensure arrow on burst disk is pointing away from meter.

1.4.9 Technical Data

Nominal Flow Rates

	15	25	40	80	100
Kg/h	2,700	9,000	32,000	85,000	250,000
Lbs/min	100	300	1,200	3,000	9,300

Maximum flow rate

Typically 130 % of the nominal flow rate for the sensor size depending on application.

Minimum flow rate

Depending on measuring error required.

Materials of construction

Measuring Tubes	SS 316L or HC-22
Flanges	SS 316L or SS316L backing with HC-22 raised face
Outer Casing	SS 304
Converter Mount & Front End electronics	SS 316L

1.4.10 Weights & Dimensions

Weights

Weight of OPTIMASS 8000/9000 sensor fitted with a typical standard flange in kg (lbs)

Model / Size	15		25		40		80		100	
	kg	lbs	kg	lbs	kg	lbs	kg	lbs	kg	lbs
8000 Sensor	10.9	24	14.4	32	23.4	51.5	61.4	135	89.4	197
9000 Sensor with insulation housing	14.9	32.8	20.4	44.8	30.9	68	79	174	125	275

Flanged & Hygienic Connections

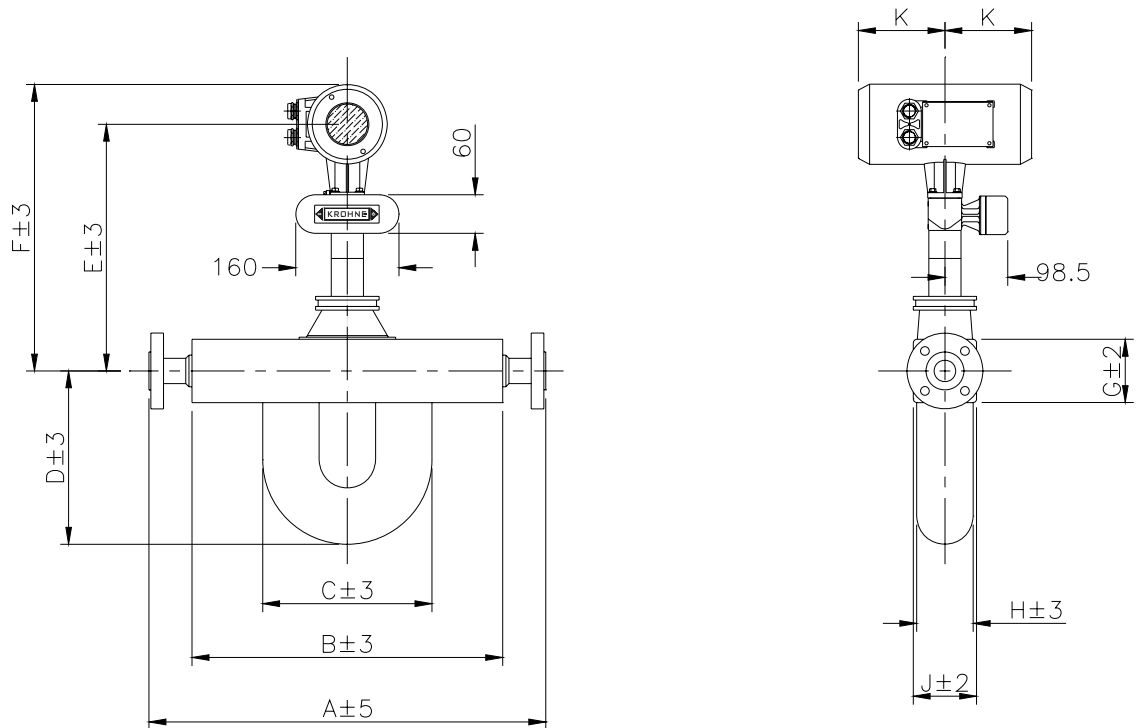

Dimension A

EN 1092-1	MATERIAL	SIZE 15		SIZE 25		SIZE 40			SIZE 80		SIZE 100	
		DN15	DN25	DN25	DN40	DN40	DN50	DN80	DN80	DN100	DN100	DN150
PN40	S/S	370	370	500	500	600	600	610	1000	1000	1100	1100
	HAST	-	390	500	520	-	620	620	1000	1000	-	-
PN 63	S/S	-	-	-	-	-	620	620	-	-	-	-
	HAST	-	-	-	-	-	-	-	-	-	-	-
PN100	S/S	380	390	520	560	620	660	730	-	-	-	-
	HAST	-	-	-	-	-	-	-	-	-	-	-

ANSI B16.5	MATERIAL	SIZE 15		SIZE 25		SIZE 40			SIZE 80		SIZE 100	
		½"	1"	1"	1.5"	1.5"	2"	3"	3"	4"	4"	6"
150 lb	S/S	370	370	500	500	600	600	610	1000	1000	1100	1100
	HAST	-	390	500	520	-	620	620	1000	1000	-	-
300 lb	S/S	-	370	-	510	-	600	620	-	-	-	-
	HAST	-	390	-	520	-	620	620	-	-	-	-
600lb	S/S	380	390	520	560	620	630	640	-	-	-	-
	HAST	-	-	-	-	-	-	-	-	-	-	-
900 lb	S/S	-	-	-	-	640	720	760	-	-	-	-
	HAST	-	-	-	-	-	-	-	-	-	-	-
1500lb	S/S	400	450	540	600	-	-	-	-	-	-	-
	HAST	-	-	-	-	-	-	-	-	-	-	-

JIS B 2220	MATERIAL	SIZE 15		SIZE 25		SIZE 40			SIZE 80		SIZE 100	
		DN15	DN25	DN25	DN40	DN40	DN50	DN80	DN80	DN100	DN100	DN150
10K	S/S	370	370	500	500	600	600	600	1000	1000	1100	1100
20K	S/S	370	370	500	500	600	600	600	1000	1000	1100	1100

Triclamp DIN32676 & ISO2852	Material	SIZE 15	SIZE 25	SIZE 40		SIZE 80
		DN25	DN40	DN50	DN65	DN100
	S/S	370	500	600	600	1020

Triclover Triclamp	Material	SIZE 15	SIZE 25	SIZE 40		SIZE 80
		1"	1 1/2"	2"	3"	4"
	S/S	370	500	600	600	1020

DIN 11851 Male	Material	SIZE 15	SIZE 25	SIZE 40		SIZE 80
		DN25	DN40	DN50		DN100
	S/S	380	510	600		1050

Other major external dimensions (for all process connections)

SIZE	B	C	D	E	F	G	H	J	K Std	K Ex
15	272	212	180	368	429	80	60	80	104	120
25	400	266	233	368	429	80	76	90	104	120
40	490	267	274	378	439	100	89	110	104	120
80	850	379	430	395	456	135	129	160	104	120
100	870	455	453	428	489	200	155	200	104	120

Insulated / Heated Jacket Meters

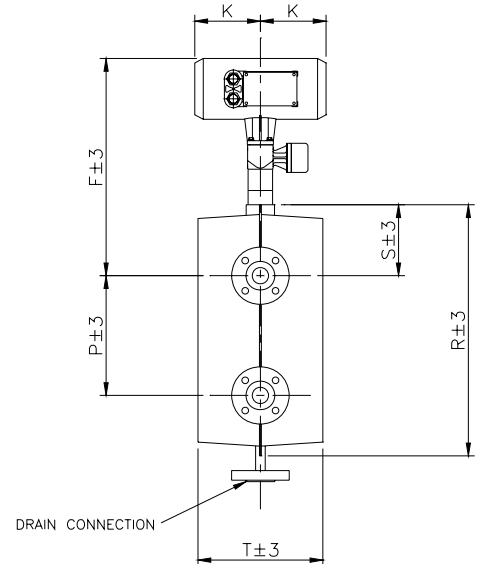
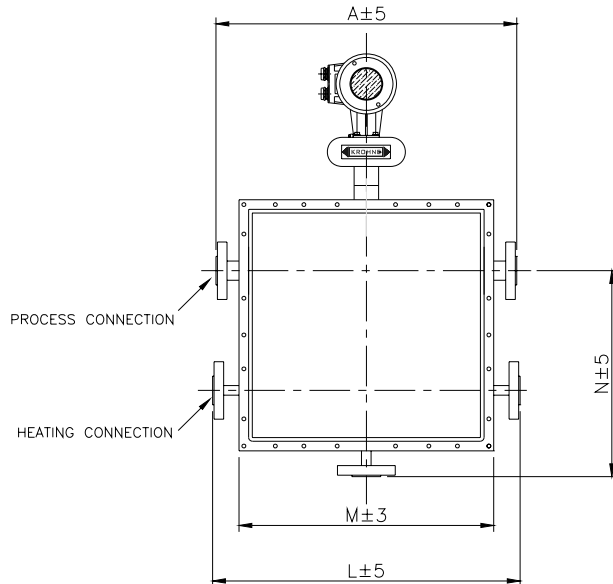
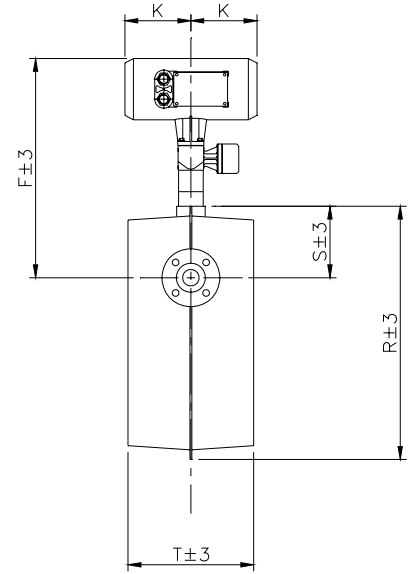
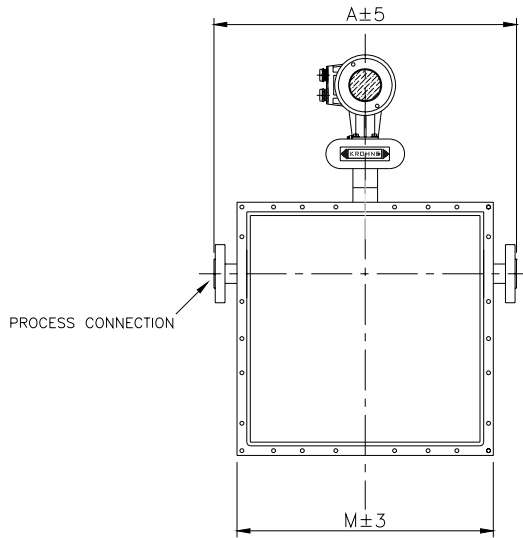

Major external dimensions of insulating and heating jacket options.

SIZE	L	M	N	P	R	S	T
15	420	310	330	200	411	138	240
25	540	439	380	250	464	138	260
40	640	530	430	250	524	148	260
80	1000	884	580	350	684	165	304
100	1040	932	590	350	730	200	343

2 Electrical Installation

2.1 Location and connecting cables

Location

Do not expose the compact flow meter to direct sunlight in hot climates. Install a sunshade if necessary.

Connecting cables

To conform to protection category requirements, observe the following recommendations:

- Fit blanking plug and apply sealant to unused cable entries.
- Do not kink cables directly at cable entries.
- Provide water drip point (U bend in cable).
- Do not connect rigid conduit to cable entries.
- Only cables of diameter 7 to 12 mm or ¼" to ½" can be used.

2.2 Connection to power



Please ensure that the information about power given on the data plate corresponds to the locally available mains voltage.

- Note information given on the instrument data plate (voltage, frequency)!
- Electrical connection in conformity with IEC 364 or equivalent national standard. Special regulations apply to installation in hazardous areas. (See supplementary installation and operating instructions)
- The PE protective ground conductor must be connected to the separate U-clamp terminal in the terminal box of the signal converter.
- Do not cross or loop the cables in the terminal box of the signal converter. Use separate cable glands for power and output cables.
- Ensure that the screw thread of the round cover on the terminal box is well greased at all times.



Note:

- The grease used must be non-corrosive to aluminium; typically it must be resin- and acid-free.
- Protect sealing ring from damage.

2.2.1 Power Supply Wiring MFC050

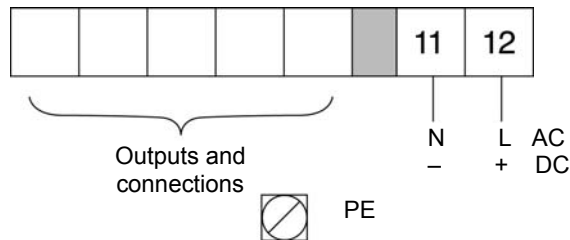

Power and signal connections for MFC 050

2.2.2 Power Supply Wiring MFC051 Non Ex 24 V AC/DC

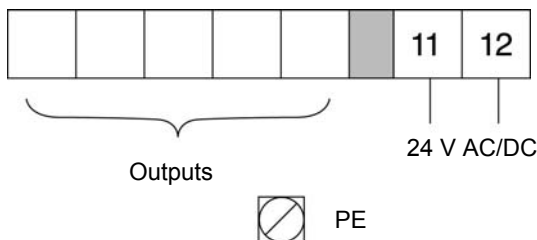

100 – 230 V AC mains

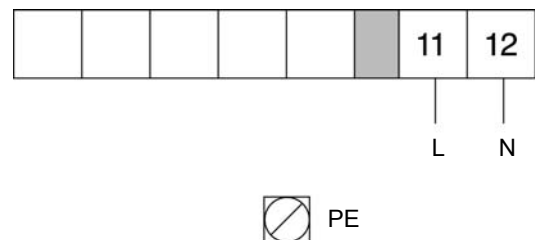

2.2.3 Power Supply Wiring MFC 051 Ex

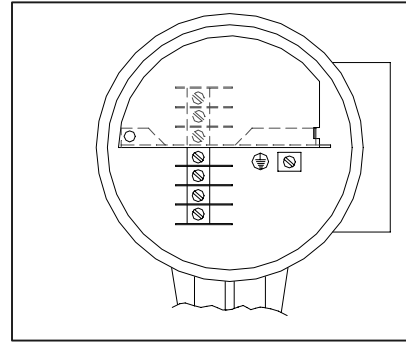
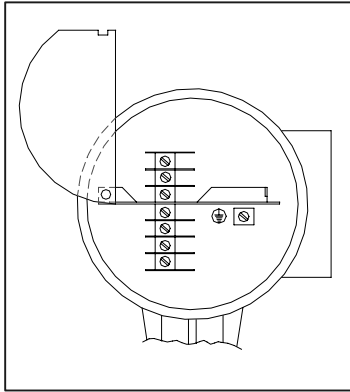

Slide the cover to the left to expose the power terminals. Power supply terminals covered.

Terminal designation as per section 2.2.2.

2.3 Connection of remote meters

The OPTIMASS meter can be supplied as a remote meter with up to 300 m or 1000 ft distance between sensor and converter.

Connect cable marked A, B, +, - to corresponding terminals in remote junction box as per sketch below.

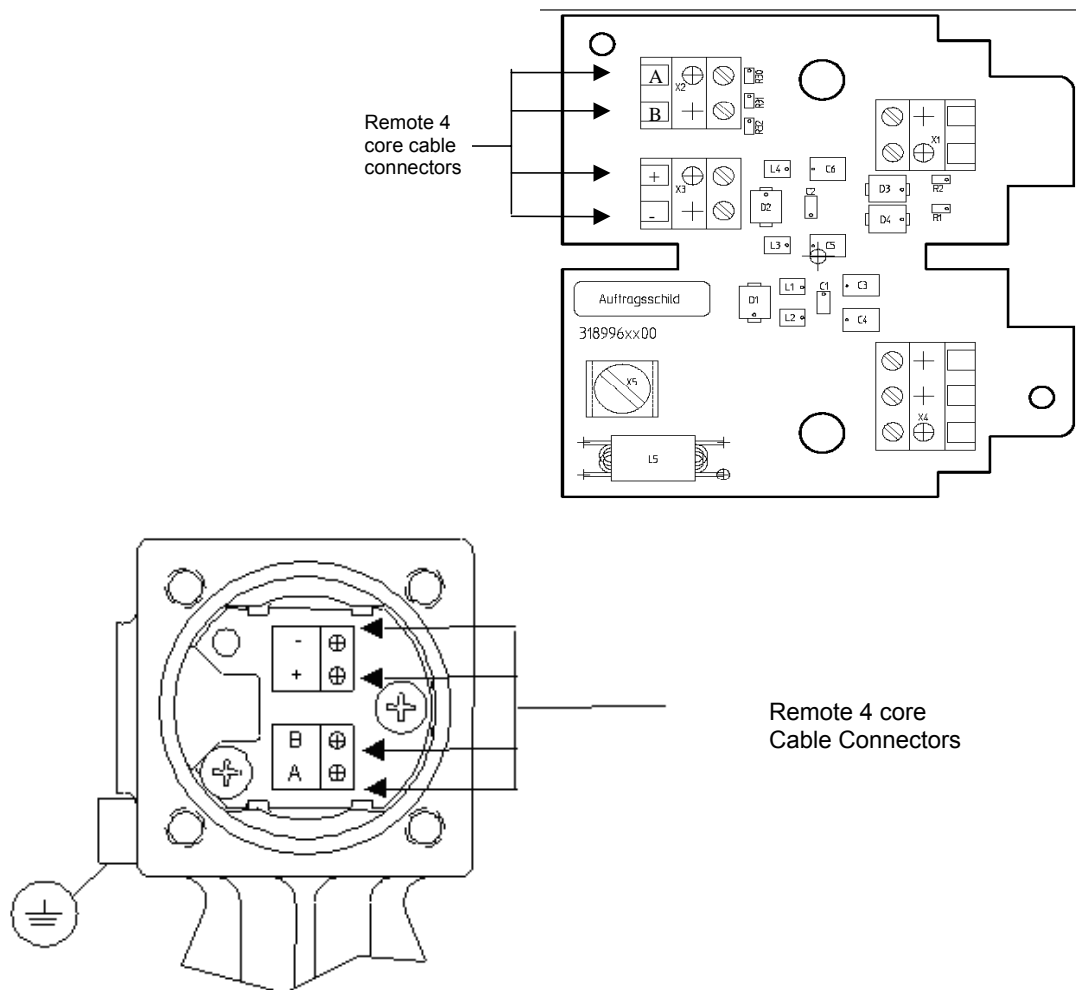

Shield is connected through the cable gland.

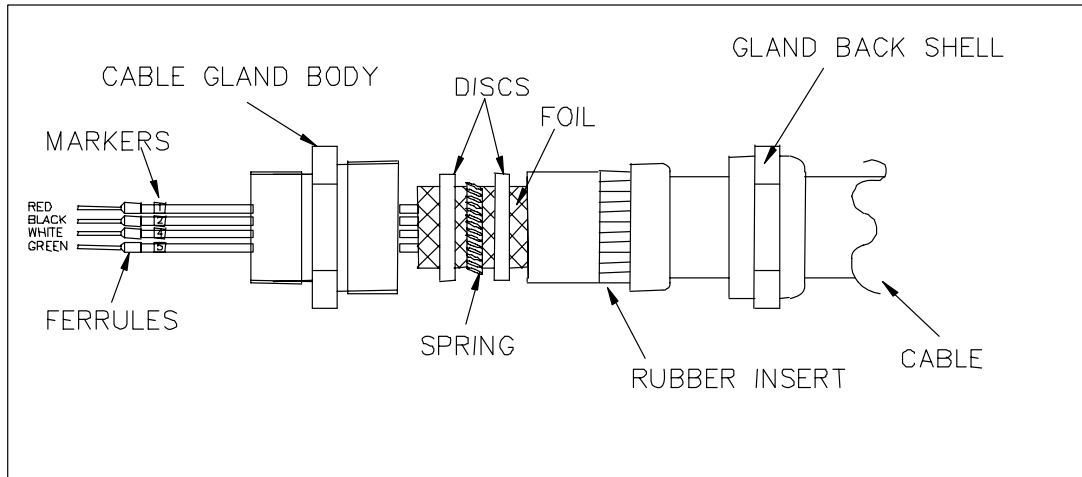

2.4 Hazardous Area requirements

- Hazardous Area Installation.
- For further information please see supplementary installation and operating instructions.
- Please follow these guidelines explicitly for mechanical and electrical connections.
- General cabling guidelines.

To maintain the IP 67 / NEMA 4x protection it is necessary to ensure that the correct size cable is used for the cable glands. Please ensure that the cable glands are well tightened. Provide a “drop” loop for water to drip off.

2.5 Inputs and outputs

2.5.1 Inputs/Outputs MFC 050

The MFC 050 has many options and variations for the inputs/outputs.

The meter is shipped from the factory with one of the following options pre-configured:

Option	Function
1	1 x current, 1 x pulse, 1 control input, 1 x status output-HART
2	1 x current plus Modbus
3	Dual phase frequency output, 1 x current, 1 x control input - HART
4	2 x current, 1 x pulse, 1 x control input, HART
5	2 x current, 1 control input, 1 x status output-HART
6	3 x current, 1 x pulse - HART
7	3 x current, 1 x control input - HART
8	3 x current, 1 x status output - HART

If you are not sure what option is fitted to the converter, this may be viewed at program Fct. 4.1 IO FITTED.

On the MFC050, the inputs/outputs have a common signal ground that is galvanically isolated from the Potential Earth (PE).



Note

HART® is available on the first current output except for option 2, where a communication option is already available.

Output Option 1

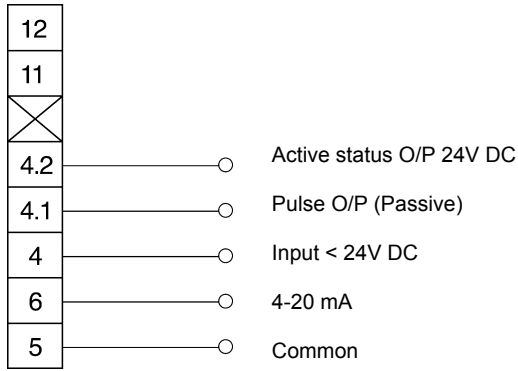

Active Status Output

The status output can be programmed to provide a constant 24V (20mA maximum) which can be used as the power source for the pulse output and control input.

Set Menu 4.6.1 to OFF
Set Menu 4.6.2 to ACTIVE LOW

Example Circuits

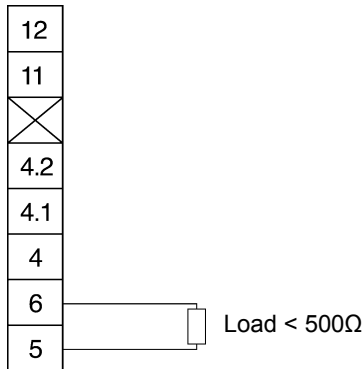

Fig 1 : 1 x current output

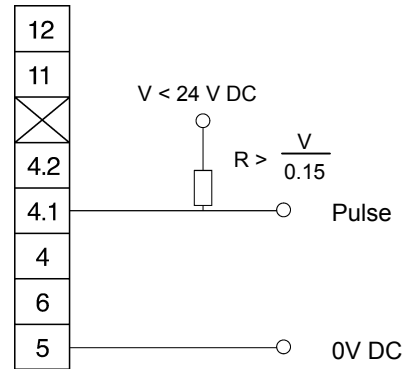

Fig 2 : Pulse output external power

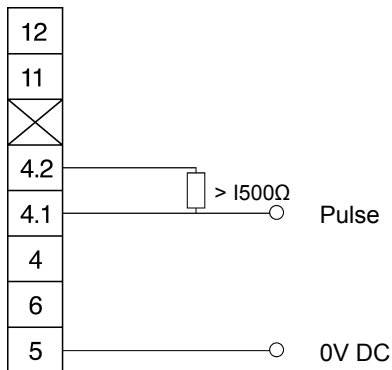

Fig 3 : Pulse output status powered

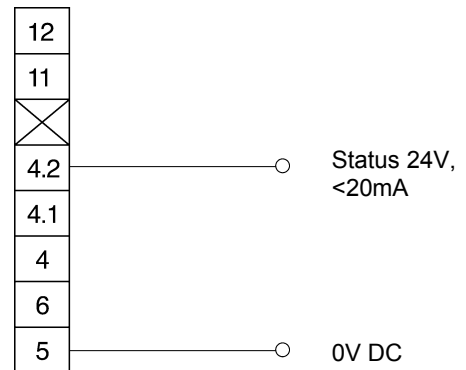

Fig 4 : Active status output

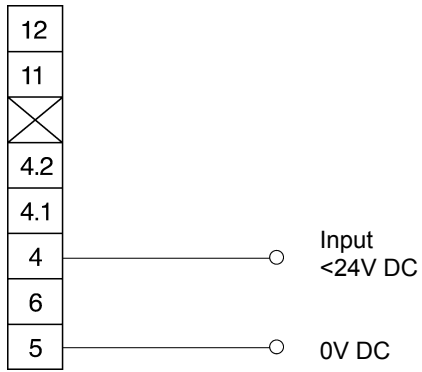

Fig 5 : Binary input

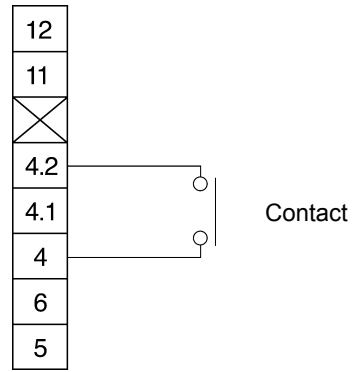

Fig 6 : Binary input status powered

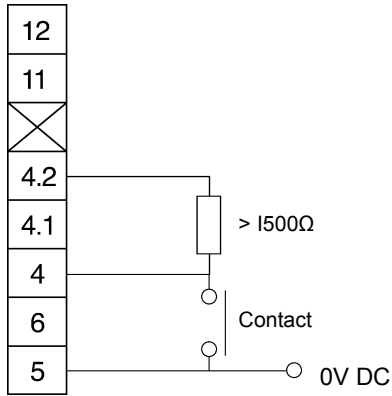

Fig 7 : Binary input status powered

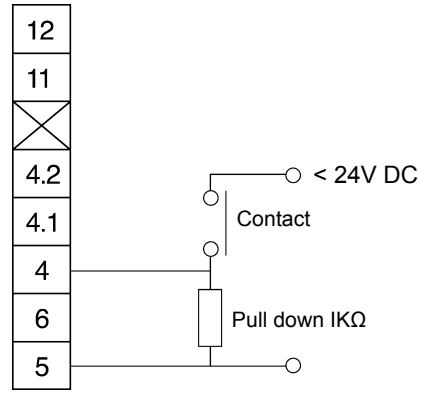

Fig 8 : Binary input external powered

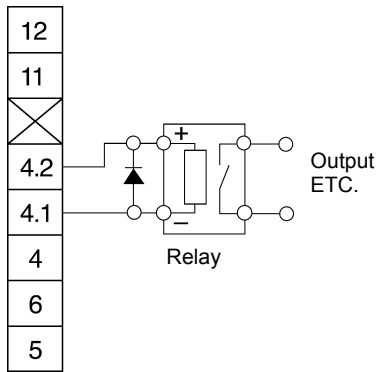

Fig 9 : Pulse relay status powered ; 24v DC <20mA relay

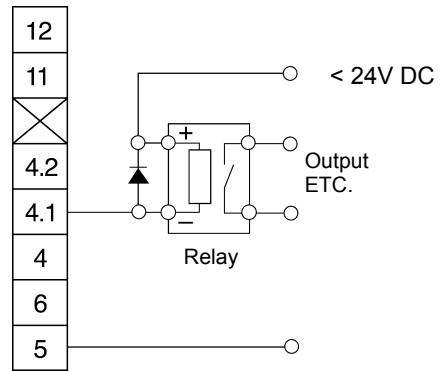

Fig 10 : Pulse relay, external powered ; 24VDC <150mA

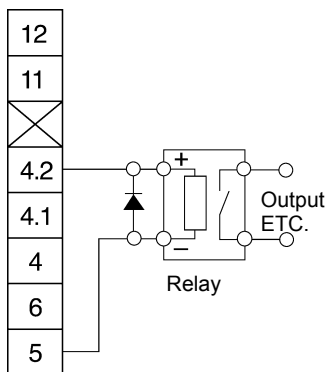
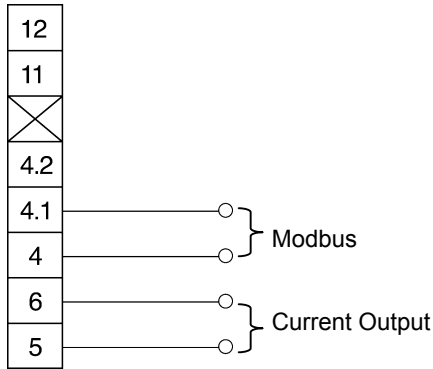

Fig 11 : Active status relay ; 24V DC <20mA relay

Output Option 2



Refer to communications handbook for details of Modbus connections

Output Option 3

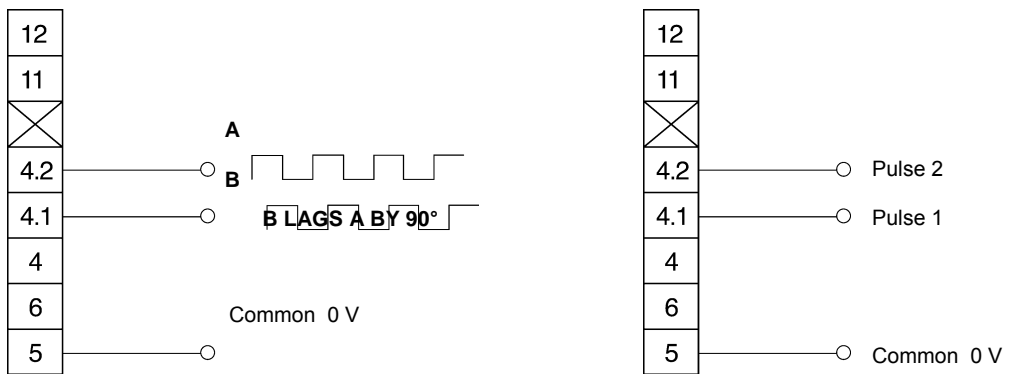

Phase shifted pulse (Passive) for Custody Transfer applications

Alternative to drive 2 pulse outputs.



Note:

It is not possible to provide two independently assignable and scaleable frequency outputs for two separate measurements.

Pulse output is passive. Refer to Figs. 2 & 10 for circuit examples.

Output Option 4

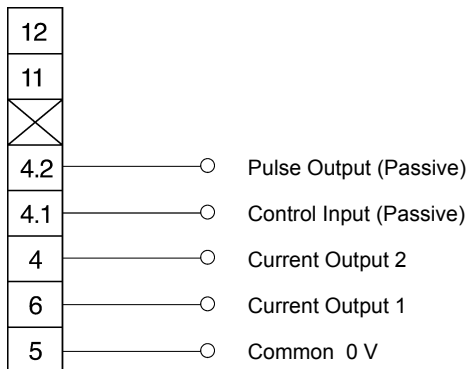

Output Option 5

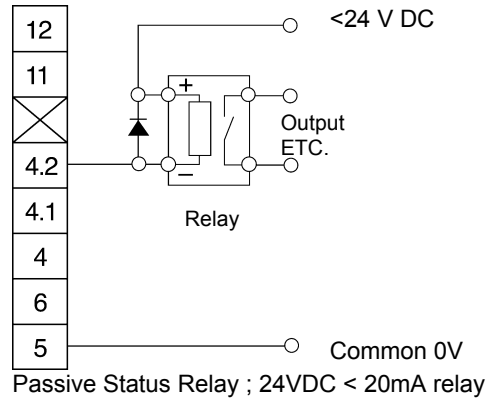
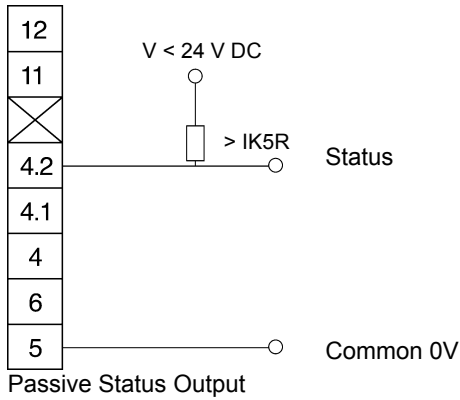
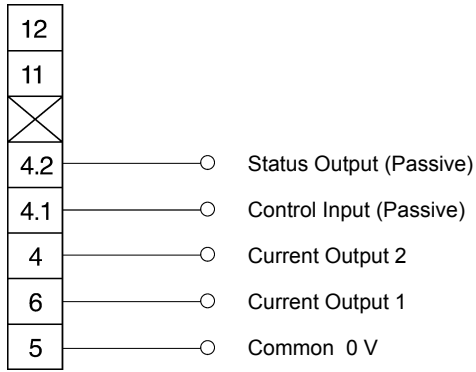

Output Option 6

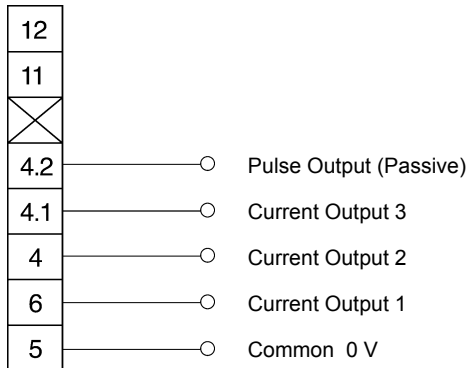

Output Option 7

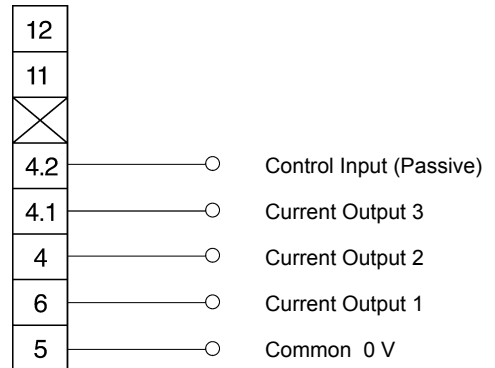

Output Option 8

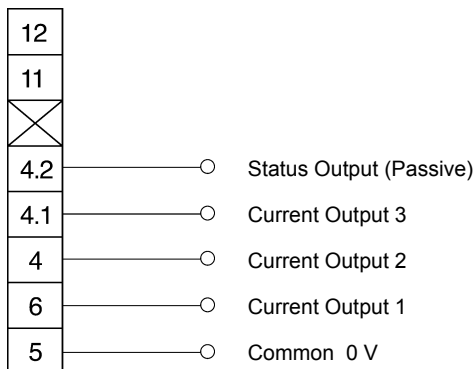

2.5.2 Inputs / Outputs MFC051

The MFC 051 offers galvanically separated outputs in the non-hazardous area version and intrinsically safe outputs for the Hazardous area approved version (see Supplementary Installation and Operating Instructions).

All outputs are passive.

The converter is shipped from the factory with the required output option fitted and configured. These cannot be changed in the field as the modules are soldered in place. The black covers over the modules are necessary to prevent spurious signals as the galvanic separation is done optically.

To view the actual outputs fitted, go to Fct. 4.1 I/O FITTED. The connection will also be indicated on an adhesive label in the lid of the terminal compartment.

Option	Function
1	2 x 4-20 mA-HART (outputs galvanically separated from each other)
2	1 x 4-20 mA, 1 X Pulse-HART
3	1 x 4-20 mA, 1 x Control input-HART
4	1 x 4-20 mA, 1 x Status output-HART
5	1 X 4-20 mA, 1 X Profibus PA



Note

HART[®] is available on the first 4...20 mA output except for option 5, where Profibus is available.

As the outputs are passive, HART[®] can be used in a multi-drop loop or as a point-to-point communication.

Output Option 1

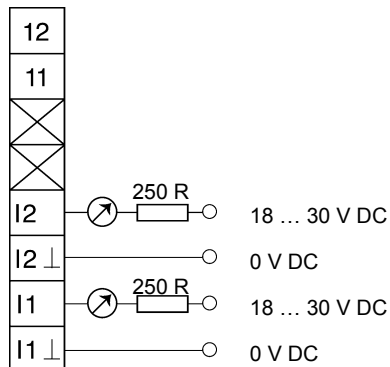

Passive current output

Output Option 2

In addition to the 1st 4...20mA, a passive pulse output can be wired as shown.

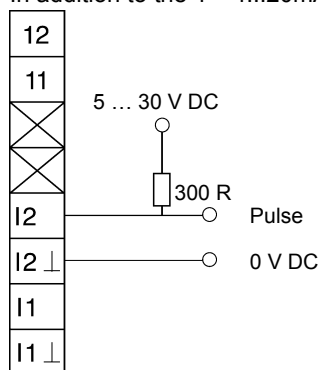

Output Option 3

In addition to the 1st 4...20mA, a control or binary input can be wired as shown.

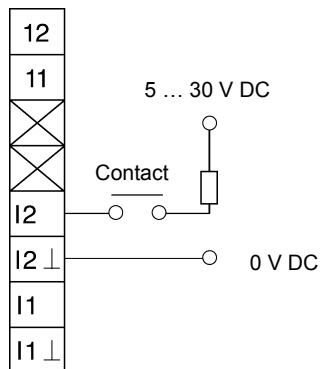

Output Option 4

In addition to the 1st 4...20 mA, a status or alarm output can be wired as shown.

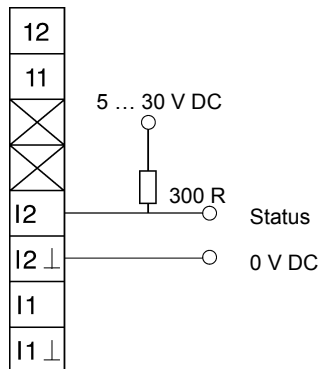

Output Option 5

The Profibus communication output available on this converter can be wired as shown in addition to a 4...20mA output. Refer to communication handbook for connection details

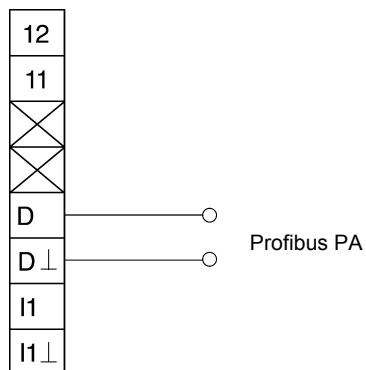

2.7.2 MFC051

Power Supply

Operating Voltage : 100 – 230V AC (+10% / -15%)
24V DC (+/- 30%)

Power consumption : AC – 18VA
DC – 10W

Inputs and Outputs

Current (mA) output

Function : Passive (externally powered)
Level : 4 ... 20mA
External Power supply : 8 ... 30V DC

Pulse Output

Function : Passive (externally powered) open collector transistor switch
Maximum Frequency : Frequency – 1300Hz, Pulse – 10 KHz
Pulse width : 0.05 ... 500 mS (settable)
External power supply : 6 ... 30V DC
Maximum circuit current : < 110mA

Control Input

Function : Passive (externally powered)
Input signal state high : 7 ... 30V DC
Input signal state low : < 2V DC or open circuit
Maximum circuit current : < 110mA

Status Output

Function : Passive (externally powered)
External circuit voltage : < 6 ... 30V DC
Maximum circuit current : < 110mA

Profibus PA

Hardware : According to IEC 61158-2 and FISCO model
External circuit voltage : 9 ... 30V DC
Maximum circuit current : < 300mA

3 Start-Up

3.1 Factory Set Parameters

The mass flow meter leaves the factory ready to be used. All process data has been programmed according to the customer order.

When no process details were supplied at the time of order, the mass flow meter is programmed to a standard default set of values and functions.

The current and pulse outputs treat all flows as positive. The actual flow and quantity is thereby measured independent of the flow direction. The indicator will indicate a " – " or " + " in front of the flow rate.

These factory-set settings for current and pulse may cause an error under the following conditions: When the pump is stopped and a reverse flow is present, which is larger than the low flow cut-off or when totalising should be indicated for both flow directions.

To avoid these possible problems:

- Set flow mode (Fct. 3.1.3) to either flow > 0 or Flow < 0, so that reverse flows are ignored.
or
- Increase Low Flow cut-off (Fct. 3.1.1) so that small reverse flows are ignored.
or
- Set the alarm output (Fct. 4.6.1) to DIRECTION so that external equipment can differentiate between positive and negative flows.

3.2 Initial Start-up

- Please check that the power supply corresponds to the information supplied on the data plate.
- Switch on the power supply.
- On switch-on, the signal converter first carries out a self-test. The following sequence is displayed:

```
* TEST
* SW.VER VX.XX
* OPTIMASS
  XX5X
* START UP
```

Mass flow will be displayed following a brief settling phase for the primary head.



A minimum warm-up time of 30 minutes is recommended to ensure stable measurement operation.

- For stable and accurate mass flow results the following should be checked:
 - a) The quality of the mechanical installation. See Sect. 1.
 - b) A good zero point calibration should be done. See Sect. 3.3. Further information regarding zero point calibration can be found in Sect. 5.

3.3 Zero point adjustment

After installation adjust the zero point. To do this, the primary head must be completely filled with the liquid product **without gas or air inclusions**. This is best obtained by allowing the liquid product to flow through the primary head for approx. 2 minutes at a throughput rate of greater than 50% of rated flow. Subsequently ensure that flow comes to a complete stop in the primary head (see Section 1.1) for setting the zero without interruption to product flow, use a bypass set-up as shown in Section 1.1.

Now initiate zero adjustment by way of the following keystroke combination:

Start from measuring mode

Key	Display	
	Line 1	Line 2
→	Fct. (1)	OPERATION
2x→ ↑	Fct. 1.1.(1)	AUTO. CALIB. CALIB. (YES)
↓	X.X	PERCENT ACCEPT. (YES)
↓ 3x↓ ↓	Fct. 1.1.(1)	AUTO. CALIB. ACCEPT. (YES) Display

Under certain conditions, it may not be possible to adjust the zero point:

- If the medium is in motion. Shut-off valves not tightly closed.
- If there are gaseous inclusions in the primary head. Flush the primary head and repeat the calibration.
- If resonant oscillations of the piping are interfering with the primary head. If there are active warning(s) in the status message list. (See section 6)

In such cases, the zero point adjustment procedure is automatically aborted and the following message is displayed:

ZERO.ERROR

Press ↓ and then the converter returns to the start of the function 1.1.1:

Fct. 1.1.1 AUTO. CALIB

Further information on zero point adjustment is given in Section 4.

The OPTIMASS is ready to operate after zero has been adjusted.

All parameters have been factory-set in keeping with the data specified in your order. Detailed information for further setting of the signal converter will be found in section 4 and 5 of the operating instructions.

3.4 Programming the converter with a bar magnet

- The converter can be programmed by means of the magnetic sensors mounted on the faceplate without removing the front lid.
- To do this, a bar magnet (standard supply) is used to activate the sensors by holding the magnet close to the glass window of the housing lid.
- These sensors then duplicate the functions of the push buttons.

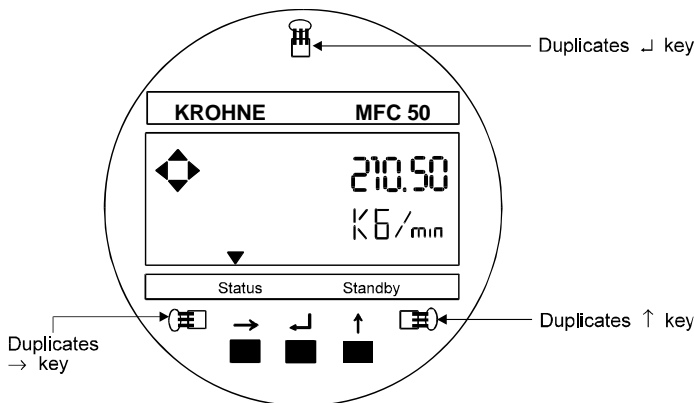

- This is mandatory in Ex environments
- Also recommended in humid environments

4 Programming the Converter MFC 050/051

4.1 Operating and check elements

The operating elements are accessible after removing the cover of the electronics section using the special wrench. The converter is also programmable with magnetic sensors and a bar magnet without removing the covers of the electronic housing.



Caution:

Do not damage the screw thread and the gasket, never allow dirt to accumulate, and make sure they are well greased at all times.

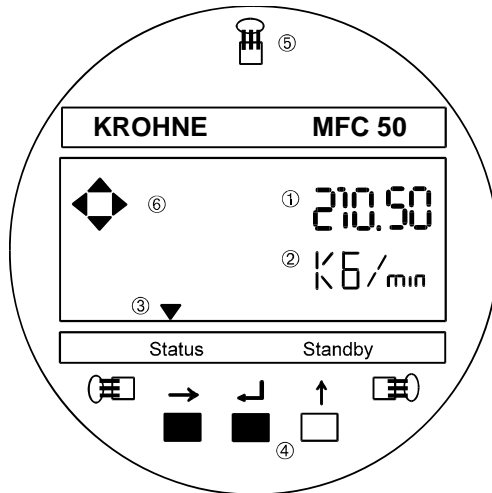

- 1 Display 1st (top) line
- 2 Display 2nd (middle) line
- 3 Display 3rd (bottom) line:
arrows (▼) to identify the state of the signal converter
 - Status message indicator
 - Standby mode
- 4 Keys for operator control of the signal converter.
- 5 Magnetic sensors to set the converter by means of a handheld bar magnet without opening the housing. Function of sensors same as keys (4).
- 6 Compass field, signals actuation of a key.

The operator control concept consists of five levels (horizontal). See next page.

Setting level:

This level is divided into 5 main menus:

Fct. 1.0 OPERATION: This menu contains most important functions for adjustment and calibration.

Fct. 2.0 TEST: Test menu for checking the signal converter (displays, outputs, measuring range) and meter diagnostics.

Fct. 3.0 CONFIG: All flow measurement- and flowmeter-specific parameters and functions can be set in this menu.

Fct. 4.0 I.O. CONFIG: The configuration of the outputs, input, communication and the system control can be set in this menu.

Fct. 5.0 FACTORY.SET: All meter related factory settings and meter constants can be monitored in this menu.

Reset/acknowledge level (Quit):

This menu has two tasks and is selected via Entry Code 2 (↵ ↑ →).

- Resetting of totalizer, provided that resetting is enabled under Fct. 3.5.3 ENABL.RESET, input YES.
- Status message and acknowledgement (Quit) messages that have occurred since the last acknowledgement are indicated in a list. After elimination of the cause(s) and acknowledgement, these messages are deleted from the list.

4.2 OPTIMASS MFC 050/051 Operating Concept

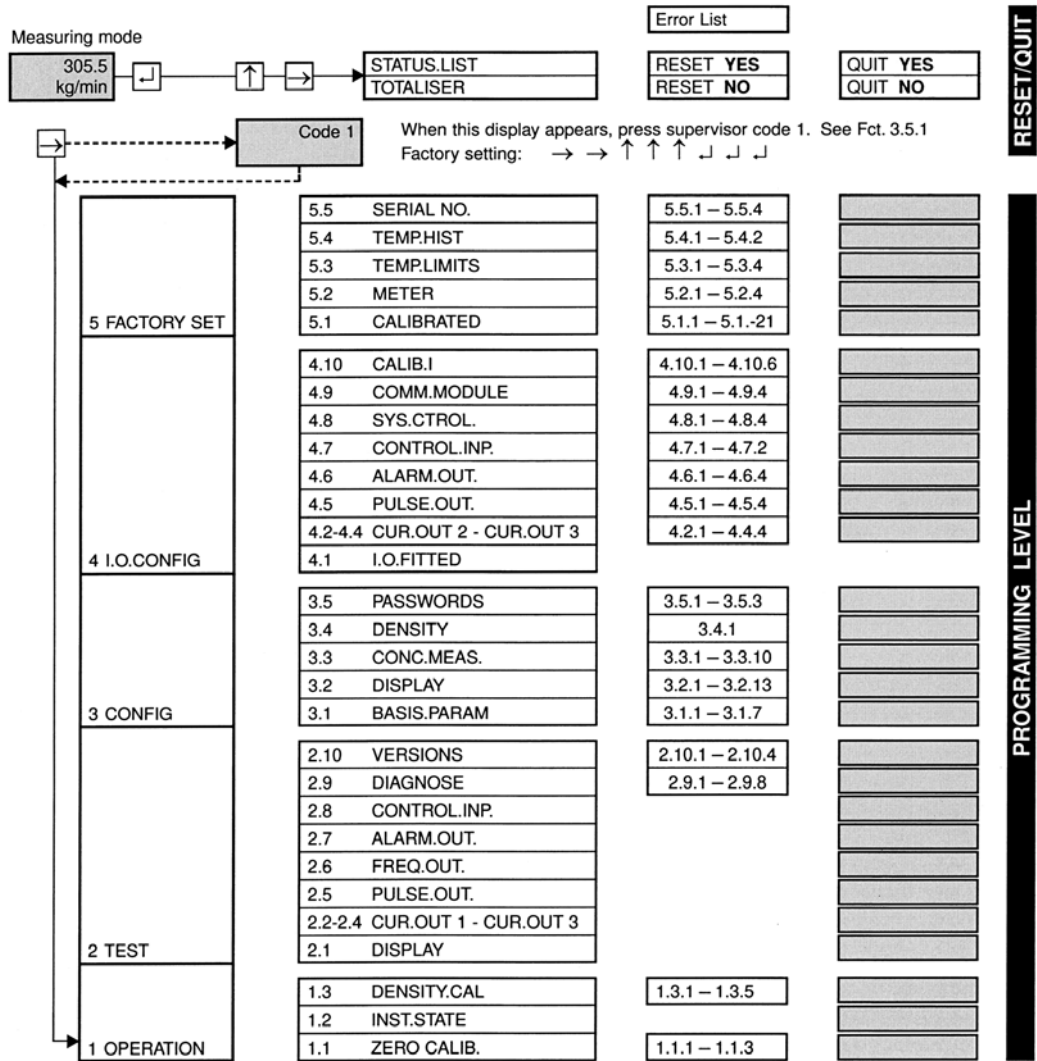

Split functions of keys between main and submenus.
The blinking part of the display (cursor) that may be changed is printed in bold.

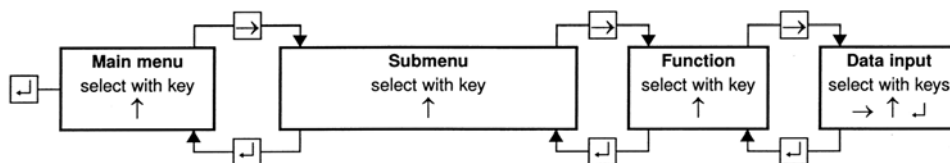

4.3 Key functions

Function of the keys	
Cursor	The location of the cursor on the display is indicated by flashing characters. This could be a single digit when entering number; numeric sign (+ or -) ; measurement units (g, kg, t etc.); or any other text field. Throughout this manual the location of the cursor, in programming examples, will be indicated by parentheses () around the flashing characters.
↑	Select or Up Key. This key changes the field/digit under the cursor.
	Digit: Increase value by 1 for each key press. (0 follows 9).
	Dec. pt.: Move decimal point. 0000(.)0000 changes to 00000(.)000
	Menu Increase menu number by 1. i.e. Fct. 1.(1).0 changes to Fct. 1.(2).0 When the menu number reaches its maximum the next ↑ changes the number to 1. i.e. Fct 1.(3)changes to Fct 1.(1)
	Text Change text field. i.e. "YES" to "NO" or "g" to "kg" to "t" etc. Sign Toggle "+" to "-"
→	Cursor or Right Key. This key moves the cursor onto the next field to be edited. (usually the next on the right).
	Number Move cursor from 12(3).50 to 123(.)50 to 123.(5)0
	Text Move to next field. i.e. (kg)/min to kg/(min)
	Menu Move to next menu column: i.e. from Fct 1.(1) to Fct. 1.1.(1) or if the cursor is already in the rightmost column: invoke that menu function. i.e. from Fct. 1.1.(1) press → to enter Zero adjustment.
↵	Accept or Enter Key.
	Within a function Accept changes (if any) and exit the function. Menu Move cursor to the next column on the left. i.e. from Fct. 1.1.(1) back to Fct. 1.(1) If the cursor is already in the leftmost column then ↵ exits the menus. See next box: "To terminate".



Note:

If numerical values are set that are outside the permissible input range, the display shows the min. or max. acceptable value. After pressing the ↵ the number may be corrected.

4.3.1 How to enter programming mode

To start:		
	Display	Comments
→ Press	Fct. 1 OPERATION or	If this appears, see box: "Function of the keys " in 4.3.
1 st - 8 th place (key)	CodE 1 -----	If this appears on the display, set the 9-keystroke Supervisor CodE 1 . Factory setting: → → → ↓ ↓ ↓ ↑ ↑ ↑
	CodE 1 *****-	Each keystroke acknowledged by " * " in display.
9 th place (key)	Fct. 1 OPERATION	If this appears, see box: "Function of the keys " in 4.3.
	XXXXX CODE WRONG	A wrong Supervisor CodE 1 was keyed in. Press any key and set the correct 9-keystroke Supervisor CodE 1.*

* If correct code is not known, note number given (XXXXX) and contact KROHNE for further instructions regarding decoding.

4.3.2 How to terminate Programming mode

To terminate:		
	Display	Comments
Press ↓ 1-5 times	Fct (1).0 OPERATION	Press ↓ 1...5 times until the cursor is under the extreme left menu column. (Fct. 1, 2, 3, 4 or 5).
↓	+ 12.3 kg/min or	If no changes have been made to the system's configuration return directly to the measurement mode.
↑	(ACCEPT YES)	Changes have been detected. Press ↓ to accept these changes.
	(ACCEPT NO)	Press ↓ to reject changes and return directly to measurement mode.
↑	(GO BACK)	Press ↓ to return to the menus, Fct. 1.(0) to make further changes
		Return to measurement mode.

Examples

The cursor (flashing part of display) has a grey background in the following examples:

To start programming

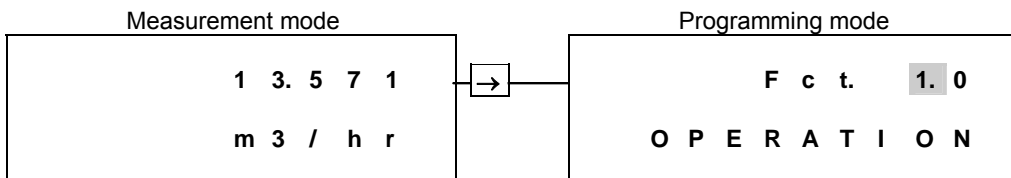

Note:

When "yes" is set under Fct. 3.5.1 SUPERVISOR, the following will appear in the display after pressing the → key:



CodE 1 -----

The 9-stroke entry code must now be entered.

Factory setting: → → → ↓ ↓ ↓ ↑ ↑ ↑.

Each keystroke is acknowledged by an "*" in the display.

To terminate programming

Press ↓ key repeatedly until one of the following menus are displayed:

Fct. 1.0 OPERATION, Fct. 2.0 TEST or Fct. 3.0 CONFIG

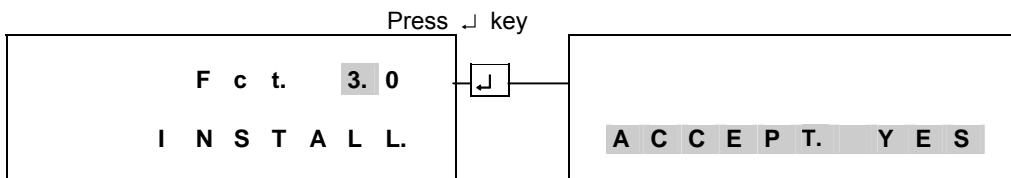

To accept the new parameters

Press ↓ to confirm.

"WAIT" will appear in the display.

The measuring mode will continue after a few seconds with the new parameters, when no errors are detected.

New parameters not to be accepted

When the new parameters are not to be accepted, the following keystrokes should be executed:

- Press ↑ key.
- The display will show "ACCEPT NO".

When the ↓ key is then pressed, the instrument will return to the measurement mode using the old parameters.

To review or change parameters further

- Press ↑ key twice
- The display will show "GO BACK".

When the ↓ key is then pressed, the instrument will return to the programming mode

To change numeric values

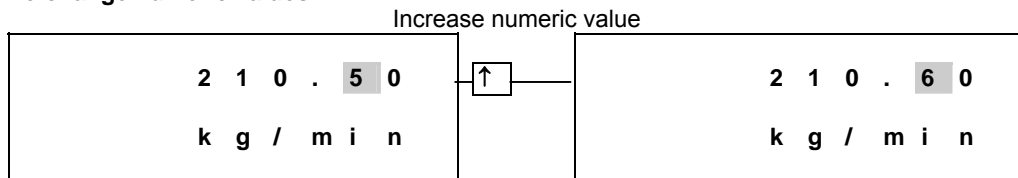

To move the cursor (flashing digit)

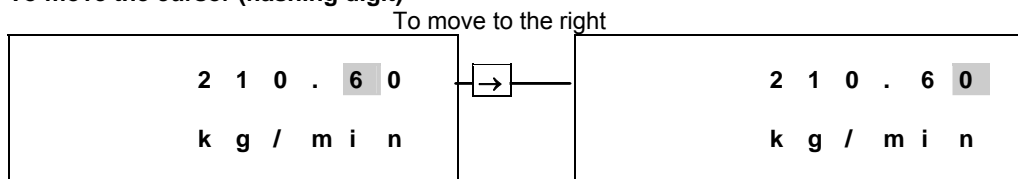

To move the decimal point

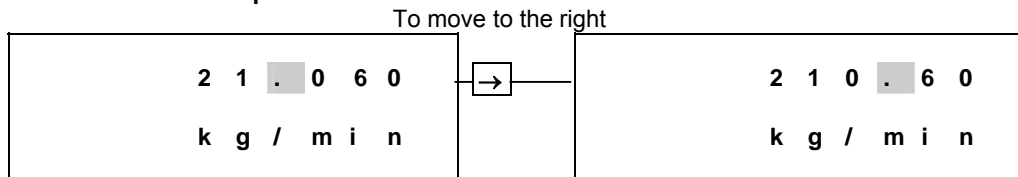

To change the text

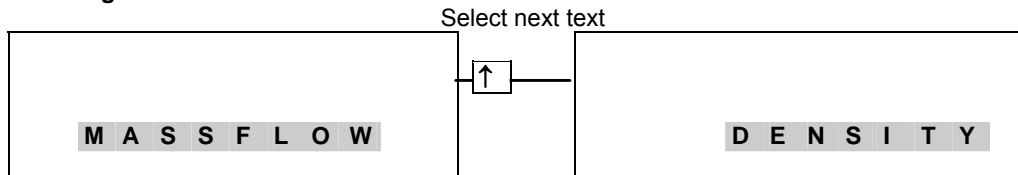

To change the units

Numeric values automatically converted

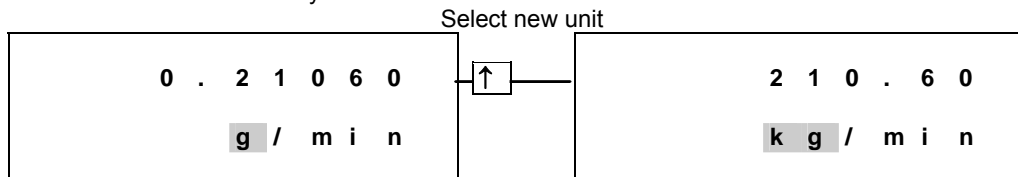

Alternative time unit

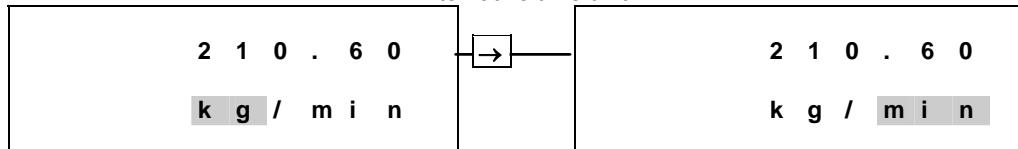

To change from numeric values back to text

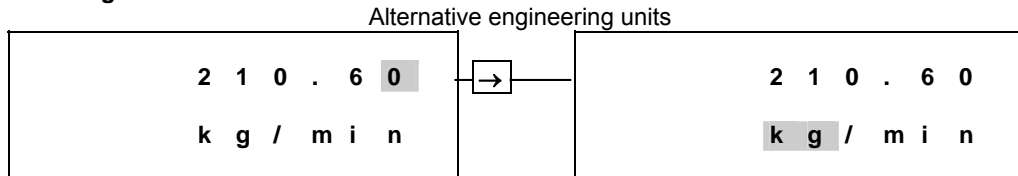

Return to function display

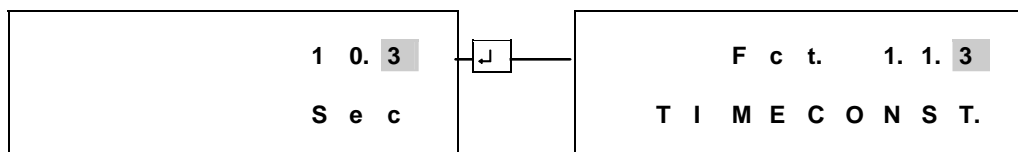

4.4 Table of programmable functions

Fct. No	Text	Description and settings
1	OPERATION	Main menu 1 Operation
1.1	ZERO CALIB.	Submenu 1.1 Zero adjustment
1.1.1	AUTO. CALIB.	Automatic zero adjustment *1) Select: SURE YES or NO *2) If YES: Calibration (approx. 30 sec. duration) Display: Actual flow rate as percent of the maximum rated flow for the primary head. ($Q_{100\%}$) *3) Select: ACCEPT YES or NO
1.1.2	MANUAL CAL.	Input manual zero offset * Direct input of a zero flow offset. Units: As selected by Fct.
1.1.3	DISP. ZERO	Display of the last zero in percent of nom. flow
1.2	INST. STATE	Input of the instrument state Use the key ↑ to switch between three states of operation, then press ↓: *MEASURE *STANDBY (tube vibrating, Mass Flow set to zero) *STOP (tube drive stopped)
1.3	DENSITY.CAL	Submenu 1.3 Density calibration
1.3.1	DISP. PT. 1	Display of last density calibration value point 1
1.3.2	DISP. PT. 2	Display of last density calibration value point 2
1.3.3	1 POINT.CAL.	Density calibration mode: 1 point calibration * SURE (NO). Use the ↑ key to select YES, then press ↓ Use the ↑ key to select desired calibration sample from the list below: * EMPTY * WATER * TOWN WATER * OTHER
1.3.4	2 POINT.CAL.	Density calibration mode: 2 point calibration 1 st access to menu 1.3.4: * SURE (NO). Use the ↑ key to select YES, then press ↓. Use the ↑ key to select between * CAL.SAMPLE1 * EXIT Press ↓ and use the ↑ key to select desired calibration sample from the list below then press ↓ * EMPTY * WATER * TOWN WATER * OTHER
	CALIB. OK.	Press ↓ to return to Fct. 1.3.4
1.3.4	2 POINT.CAL	2nd access to menu 1.3.4: * SURE (NO). Use the ↑ key to select YES, then press ↓. Use the ↑ key to select between * CAL.SAMPLE2 * RESTART * EXIT Press ↓ and use the ↑ key to select desired calibration sample from the list below then press ↓. * WATER * TOWN WATER * OTHER
	CALIB. OK	Press ↓ to return to Fct. 1.3.4
1.3.5	FACTORY.SET	Reset factory settings Restore density calibration to factory settings * SURE (NO). Use the ↑ key to select YES, then press ↓.

Fct. No	Text	Description and settings
2	TEST	Main Menu 2. Test functions
2.1	DISPLAY.	Carry out display test * SURE (NO). Use the ↑ key to select YES, then press ↵ (Duration of test approx. 30 sec.). Stop test at any time with the ↵ key.
2.2	CUR. OUT. 1	Test current output 1 * SURE (NO). Use the ↑ key to select YES, then press ↵. Use the ↑ key to select test signals from the list below. 0 mA 2 mA 12 mA 16 mA 20 mA 22 mA To exit test mode, press the ↵ key at any time.
2.3	CUR. OUT. 2	Test current output 2 see CUR. OUT. 1 above
2.4	CUR. OUT. 3	Test current output 3 see CUR. OUT. 1 Fct. 2.2 above
2.5	PULSE OUT.	Test frequency output * SURE (NO). Use the ↑ key to select YES, then press ↵. Use the ↑ key to select desired pulse width from the list below: * 0.05 mSec * 0.4 mSec * 1.0 mSec * 10.0 mSec * 100.0 mSec * 500.0 mSec Then press ↵. The system now sends pulses of the required width. To stop the test press ↵ twice.
2.6	FREQ. OUT.	Test frequency output * SURE (NO). Use the ↑ key to select YES, then press ↵. * LEVEL LOW 0 volt DC level will be output from the converter. Use the ↑ key to select test signals from the list below. * LEVEL HIGH (+ V volts dc) * 1 Hz * 100 Hz * 10 Hz * 1000 Hz
2.7	ALARM OUT.	Test alarm output * SURE (NO). Use the ↑ key to select YES, then press ↵ * LEVEL LOW. 0 Volts is output on the alarm terminal. Press the ↑ key to switch output to: * LEVEL HIGH . +24V dc is output on the alarm terminal. To exit test mode, press the ↵ key at any time.
2.8	CONTROL.INP	Test control input * SURE (NO). Use the ↑ key to select YES, then press ↵. The actual input level, HI or LO, and the selected functions are displayed see Fct. 3.6.1 End test by pressing the ↵ key.
2.9	DIAGNOSE	Submenu 2.9 Diagnose
2.9.1	TUBE TEMP.	Test temperature Start with the → key. The temperature in °C or °F is displayed. Use the ↑ key to display the temperature in °F. End the test by pressing the ↵ key.
2.9.2	STRAIN M.T.	Test strain measuring tube Start with the → key. The strain resistance in Ohms is displayed. End the test by pressing the ↵ key.
2.9.3	STRAIN I.C.	Test strain inner cylinder Start with the → key. The strain resistance in Ohms is displayed. End the test by pressing the ↵ key.
2.9.4	TUBE FREQ.	Monitor the primary head frequency Start test with the → key. End the test with the ↵ key.
2.9.5	DRIVE.ENERGY.	Monitor the primary head's drive level Start test with the → key. End test with the ↵ key.
2.9.6	SENSOR A	Monitor the amplitudes of sensor A and B as percentage of their max. value. Value should correspond to amplitude setting in Fct. 5.2.4 Start test with the → key. End the test with the ↵ key.
2.9.7	SENSOR B	
2.9.8	COMM.ERROR S	Monitor communication errors Start test with the → key. Number of communication errors since power on is displayed. End the test with the ↵ key.
2.10	VERSIONS	Submenu 2.10 Versions
2.10.1	BACKEND.SW	Monitor the backend software version Start test with the → key. End test with the ↵ key.
2.10.2	BACKEND.HW	Monitor the backend hardware version Start test with the → key. End test with the ↵ key.
2.10.3	FRONTEND.SW	Monitor the frontend software version Start test with the → key. End test with the ↵ key.

Fct. No	Text	Description and settings
3	CONFIG	Main menu 3 Configuration
3.1	BASIS.PARAM	Submenu 3.1 Base data
3.1.1	L.F. CUTOFF	Low flow cut-off Value: 0 to 10 percent of nominal flow
3.1.2	TIME CONST.	Time constant for output of measured values Range 0,2 ... 20 sec.
3.1.3	FLOW MODE	Define whether bi-directional or uni-directional flow is expected. Select either: * FLOW > 0 (Ignore negative flows) * FLOW < 0 (Ignore positive flows) * FLOW +/- (Allow positive and negative flows)
3.1.4	FLOW DIR.	Define direction of flow Select either FORWARD or BACKWARD
3.1.5	PIPE DIAM.	Select the pipe diameter Input of the pipe diameter in mm for the flow velocity measurement. Default value: Tube diameter for the sensor size
3.1.6	ADD. TOTAL	Use the key ↑ to add one additional totaliser Select, then press ↓: * NONE * MASS TOTAL * VOLUME TOT * CONC.TOTAL.
3.1.7	ERROR MSG	Which status messages to be displayed? Use the key ↑ to select, then press ↓ * BASIC.ERROR * TRANS.ERROR * I.O. ERRORS * ALL ERRORS
3.1.8	PRESS TIME	Pressure Suppression Time Range: 0.0 (OFF) ... 20.0 Seconds
3.1.9	PRESS CUTOF	Pressure Suppression Cut Off Range: 0.0 ... 10.0%
3.2	DISPLAY	Submenu 3.2 DISPLAY
3.2.1	CYCL. DISP.	Cyclic display required? Setting STATIC.DISP. or CYCLE.DISP. If CYCLE.DISP. is selected then in measurement mode the display will switch from Mass Flow to Density to Total to Temperature every 5 seconds.
3.2.2	MASS FLOW	Units and format for mass flow display * g, kg, t, oz, lb per s, min, h, d * Number of digits after the decimal point selectable.
3.2.3	TOTAL MASS.	Units and format for totaliser * g, kg, t, oz, lb * Number of digits after the decimal point selectable.
3.2.4	VOLUME.FLOW	Units and format for volume flow * Select OFF (no volume flow display) or * cm3, dm3, litre, m3, in3, ft3, USgal, or gallon per * s, min, hr, day * Number of digits after the decimal point selectable.
3.2.5	VOL.TOTAL	Units and format for totalizer * Select OFF (no volume total display) or cm3, dm3, liter, m3, inch3, ft3, US gal, gallon.
3.2.6	TEMPERATUR.	Units for temperature * °C or °F * Format fixed at 1 decimal place
3.2.7	DENSITY	Units and format for density * g, kg, t, per cm3, dm3, litre, m3 or oz, lb per in3, ft3, USgal, gallon or SG (Specific Gravity relative to water at 20°C) * Number of digits after the decimal point selectable.
3.2.8	CONC. FLOW	Units and format for mass flow of dissolved medium * Select OFF (no mass flow rate of the dissolved medium on display) or * g, kg, t, oz, lb per s, min, h, d * Number of digits after the decimal point selectable.
3.2.9	CONC. TOTAL	Units and format for mass totaliser of dissolved medium * Select OFF (no mass flow total of the dissolved medium on display) or * g, kg, t, oz, lb * Number of digits after the decimal point selectable.
3.2.10	CONC.BY.MASS	Monitor concentration by mass * Select OFF (no concentration by mass on display) or * PERCENT M

Fct. No	Text	Description and settings
3.2.11	CONC.BY.VOL.	Monitor concentration by volume * Select OFF (no concentration by volume on display or) * PERCENT V
3.2.12	VELOCITY	Monitor flow velocity * Select OFF (no flow velocity on display or) * m/sec * ft/sec
3.2.13	LANGUAGE	Language for display text * ENGLISH * FRANCAIS * ESPANOL * DEUTSCH
3.3	CONC. MEAS.	Submenu 3.3 Concentration measurement
3.3.1	CONC. MODE	* NOT FITTED (no concentration measurement available) or select option (only if concentration was ordered): * NONE * BRIX * GEN. CONC. * BAUME 144.3 * BAUME 145.0 * NAOH * PLATO
3.3.2	ENABLE.CONC	Enter the access code for concentration measurement
		If access is enabled:
3.3.2	OFFSET	Offset for concentration measurement Input manual concentration offset * Direct input of a concentration offset.
3.3.3	CONC TYPE	
3.3.4	CONC CF1	Refer to separate concentration manual
3.3.12	CONC CF12	
3.4	DENSITY	Submenu 3.4 Density
3.4.1	DENS. MODE	Option density mode Press key ↵, select with key → and ↑ unit and value, quit with key ↵ back to function 3.1.5. FIXED (Norm density) REFERRED (temperature-referred density) ACTUAL (operating density)
3.4.2	FIXED	Input of the fixed density for the option „FIXED“ only
3.4.2	REF TEMP	Input of the reference temperature for the option „REFERRED“ only
3.4.3	SLOPE	Input of the slope for the option „REFERRED“ only
3.5	PASSWORDS	Submenu 3.5 Passwords
3.5.1	SUPERVISOR	Supervisor code for accessing menus required? Use the key ↑ to select, then press ↵. * ENABLE PW * CHANGE PW (set a 9-keystroke code) * EXIT Default setting: → → → ↵ ↵ ↵ ↑ ↑ ↑
3.5.2	CUSTODY	Custody transfer code required?
3.5.3	TOTAL.RESET	Totaliser reset enabled? Use the key ↑ to select, then press ↵. * ALLOW.RESET (reset unblocked) * COMM RESET (reset via communication options is enabled) * NO RESET (reset blocked)
3.6	SETTINGS	Submenu 3.6 Settings
3.6.1	TAG ID.	Tag name setting (measuring point number) Required only for flow meters using the MIC 500 Hand Held Communicator (HHC), connected to current output.. Factory setting: "MFC 050 (or MFC 51)" Characters assignable to each place: A...Z / 0...9 / + / - / * / = / / / (> = blank character)

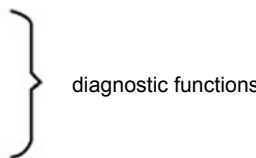
Fct. No	Text	Description and settings
4	I.O. CONFIG	Main menu 4 Input/output configuration
4.1	I.O. FITTED	Submenu 4.1 Fitted inputs and outputs
	MFC 050	<p>Setting of fitted input/output modules</p> <ul style="list-style-type: none"> * NONE * I * I F A B (1 current op, 1 pulse/frequency op, 1 alarm op, 1 control ip) * I Fcl B (1 current op, 1 dual phase shifted frequency op, 1 control ip) * I RS485 (1 current op, Modbus) <hr/> <p>Multi I/O outputs can be changed by programming:</p> <ul style="list-style-type: none"> * 2I A B (2 current op, 1 alarm op, 1 control ip) * 2I F B (2 current op, 1 pulse/frequency op, 1 control ip) * 3I F (3 current op, 1 pulse/frequency op) * 3I B (3 current op, 1 control ip) * 3I A (3 current op, 1 alarm op)
	MFC 051	<ul style="list-style-type: none"> * I F GI (1 current op, 1 pulse/frequency op, galv. isol.) * I A GI (1 current op, 1 alarm op, galvanically isolated) * I B GI (1 current op, 1 control ip, galvanically isolated) * 2I GI (2 current op, 1 alarm op, galvanically isolated) * I Bus GI (1 current op, 1 Profibus, galv. isolated)
4.2	CUR. OUT. 1	Submenu 4.1 Current output 1
4.2.1	FUNCTION	<p>Function current output I</p> <ul style="list-style-type: none"> * OFF (O/P current = 0 mA) * MASS FLOW (Mass flow in range LOW [Fct. 4.2.3] to HIGH [Fct. 4.2.4] output as current in range [Fct 4.2.2] 0/4-20mA) * DENSITY (Density in range LOW [Fct. 4.2.3] to HIGH [Fct. 4.2.4] output as current in range [Fct 4.2.2] 0/4-20 mA) * VOL.FLOW (Volume flow in range LOW [Fct. 4.2.3] to HIGH [Fct. 4.2.4] output as current in range [Fct 4.2.2] 0/4-20 mA) * TEMPERATUR (Temperature in range LOW [Fct. 4.2.3] to HIGH [Fct. 4.2.4] output as current in range [Fct 4.2.2] 0/4-20 mA) * CONC. FLOW Concentration measurement * CONC. BY MASS functions available if installed * CONC.BY.VOL. (see sep. instruction manual). * DIRECTION (Negative flow gives current of 0/4 mA, positive flow gives current of 20 mA) * REF.DENSITY (see DENSITY) * SENSOR AVG. * SENSOR DEV. * DRIVE.ENEY. * TUBE FREQ. * STRAIN M.T. * STRAIN I.C. * VELOCITY [flow velocity in range LOW [Fct. 4.2.3] to HIGH [Fct. 4.2.4] output as current in range[Fct 4.2.2] 0/4-20 mA) <div style="text-align: right; margin-top: 10px;">  <p>diagnostic functions</p> </div>
4.2.2	RANGE I	<p>Range for current output I:</p> <p>Select from the following by pressing ↑ key and then ↵ key.</p> <ul style="list-style-type: none"> * 0 -20 mA * 0-20/22 mA (O/P = 22 mA when error detected) * 4 -20 mA * 4-20/2 mA (O/P = 2 mA when error detected) * 4-20/3.5 mA (O/P = 3.5 mA when error detected) * 4-20/22 mA (O/P = 22 mA when error detected)
4.2.3	LOW LIMIT	Value of measured quantity as set by Fct. 4.2.1, that corresponds to the minimum output current (0 or 4 mA as set by 4.2.2)
4.2.4	HIGH LIMIT	Value of measured quantity as set by Fct. 4.2.1 that corresponds to an output current of 20 mA. Menu not available if Function 4.2.1 is set to OFF.
4.3	CUR. OUT. 2	Submenu 4.2 Current output 2 Display "NOT FITTED" after access if not available Programming see Submenu 4.2 CUR. OUT. 1
4.4	CUR. OUT. 3	Submenu 4.3 Current output Display "NOT FITTED" after access if not available Programming see Submenu 4.2 CUR. OUT. 1

Fct. No	Text	Description and settings
4.5	PULSE OUT.	Submenu 4.5 Pulse/frequency output
4.5.1	FUNCTION	<p>Function pulse/frequency output P</p> <ul style="list-style-type: none"> * OFF (Output = 0V DC) * MASS FLOW (Frequency output 0 to MAX Freq. Hz = Mass Flow in range: MIN. FLOW to MAX FLOW as set in Fct. 4.5.2 and 4.5.3) * DENSITY (Frequency output 0 to MAX Freq. Hz = Density in range: MIN.DENSITY to MAX.DENSITY as set in Fct. 4.5.2 and 4.5.3) * MASS TOTAL(1 pulse = fixed mass as set in Fct 4.5.2) * VOLUME.FLOW(Frequency output 0 to MAX Freq. Hz = Volume flow in range: MIN. V.FLOW to MAX. V.FLOW as set in Fct. 4.5.2 and Fct. 4.5.3) * VOL.TOTAL(1 pulse = fixed volume as set in Fct 4.5.2) * TEMPERAT. (Frequency output 0 to MAX Freq. Hz = Temperature in range: MIN. TEMP to MAX. TEMP as set in Fct. 4.5.2 and 4.5.3) <p> CONC. FLOW CONC. TOTAL CONC.BY.MASS CON:BY:VOL. </p> <p style="text-align: right;">} Concentration parameters if option installed. See separate instruction manual.</p> <ul style="list-style-type: none"> * DIRECTION (Negative flow gives output of 0 volts DC, Positive flow gives output of +V volts DC) * ADDITIONAL(1 pulse = fixed mass as set in Fct 4.5.2)
4.5.2	LOW LIMIT	Value of measured quantity that corresponds to 0 Hz output or Minimum Width in mS of Pulse for functions MASS TOTAL, VOL. TOTAL or CONC. TOTAL
or	PULSE.WIDTH	TOTAL
4.5.3	HIGH LIMIT	Value of measured quantity that corresponds to Max. Frequency or Mass or volume per pulse value for functions MASS TOTAL, VOL. TOTAL or CONC. TOTAL
or	PULSE VAL.	TOTAL
4.5.4	MAX FREQ	Value of max. frequency quantity that corresponds to the max. measured value Not accessible for functions OFF, MASS TOTAL, VOL. TOTAL or CONC. TOTAL

Fct. No	Text	Description and settings
4.6	ALARM. OUT	Sub menu 4.6 Process alarm output
4.6.1	FUNCTION	<p>Function for alarm output</p> <ul style="list-style-type: none"> * OFF (Output goes to its inactive state) * MASS FLOW (Alarm active if mass flow goes outside limits as set in Fcts. 4.2 to 4.5) * DENSITY (Alarm active if density goes outside limits as set in Fcts. 4.2 to 4.5) * MASS TOTAL (Alarm active if totaliser goes outside limits as set in Fcts. 4.2 to 4.5) * VOLUME.FLOW (Alarm active if volume flow go outside limits as set in Fcts. 4.2 to 4.5) * VOL.TOTAL (Alarm active ...) * TEMPERAT. (Alarm active if temperature goes outside limits as set in Fcts. 4.2 to 4.5) * CONC. FLOW * CONC. TOTAL * CONC.BY.MASS * CONC.BY.VOL. <p style="margin-left: 150px;">} Concentration option if installed. See separate instruction manual.</p> <ul style="list-style-type: none"> * DIRECTION (Output active for positive flows, inactive for negative flows) * SEVERE ERR. (Output active if a severe error is detected) * ALL ERRORS (Output active if any warnings occur) * I1.SAT (Alarm active if value output on current output exceeds the range as set in Fct. 4.2.3 and 4.2.4) * I2 SAT. and I3 SAT. see I1 SAT. * PULSE SAT (Alarm active if value output on pulse output is either: > 1.3 x Max Limit as set in Fct 4.5.3 or < Min Limit as set in Fct 4.5.2) * ANY O/P.SAT (Alarm active if value output on either current or pulse output exceeds the selected ranges) * VELOCITY (Alarm active if flow velocity goes outside limits as set in Fcts. 4.2 to 4.5) * ADDITIONAL (Alarm active if additional totaliser goes outside limits as set in Fcts. 4.2 to 4.5)
4.6.2	LOW LIMIT or	<p>Minimum allowable value for functions TOTAL MASS, MASS FLOW, DENSITY, TEMPERATUR, VOLUME.FLOW, VELOCITY, ADDITIONAL and concentration functions Units: depend on function but will correspond to those set in Submenu 3.2; Not accessible for all other functions.</p>
4.6.3	HIGH LIMIT. or	<p>Maximum allowable value for functions MASS TOTAL, MASS FLOW, DENSITY, TEMPERATUR, VOLUME.FLOW, VELOCITY, ADDITIONAL Units: depend on function but will correspond to those set in Submenu 3.2.; Not accessible for all other functions</p>
4.6.4	ACTIVLEVEL	<p>Select the desired voltage level for the active state</p> <ul style="list-style-type: none"> * ACTIVE.HIGH (24 V dc) * ACTIVE LOW (0 V dc)
4.7	CONTROL.INP	Submenu 4.7 Control input
4.7.1	FUNCTION	<p>Function of the control input</p> <ul style="list-style-type: none"> * INACTIVE (control input inactive) * STANDBY (When active converter switches to STANDBY) * STOP (When active converter switches to stop vibration) * ZERO CALIB. (Zero calibration triggered on the transition from inactive to active on the control input) * TOTAL.RESET (Totaliser reset to zero on the transition from inactive to active on the control input) * QUIT.ERRORS (Status warnings cleared on the transition from inactive to active on the control input)
4.7.2	ACTIVLEVEL	<p>Set the desired voltage level for the input to be active</p> <ul style="list-style-type: none"> * ACTIVE LOW (0...2 V) * ACTIVE.HIGH (4...24 V)

Fct. No	Text	Description and settings
4.8	SYS.CTROL	Submenu 4.8 System control
4.8.1	FUNCTION	Function for system control * OFF (System control inactive) * FLOW = 0 (Mass flow readings forced to zero, totaliser frozen) * FLOW = 0/RST. (Mass flow readings forced to zero, totaliser frozen while active but reset to zero as condition becomes inactive. Not available with Custody Transfer Protection) * OUTPUTS.OFF (Forces all outputs to their OFF states)
4.8.2	CONDITION	Condition for triggering the above function * DENSITY (Function is triggered if density goes outside Max or Min limits as set in Fcts 4.8.3 and 4.8.4) * TEMPERATUR (Function is triggered if temperature goes outside Max or Min limits as set in Fct 4.8.3 and 4.8.4). Function not available with Custody Transfer Protection.
4.8.3	LOW LIMIT	Minimum allowable value of temperature or density selected in Fct. 4.8.2 Units: depend on function but will correspond to those set in Fct. 3.2.6 and 3.2.7 Function not available with Custody Transfer Protection.
4.8.4	HIGH LIMIT	Maximum allowable value of temperature or density selected in Fct.4.8.2 Units: depend on function but will correspond to those set in Fct. 3.2.6 and 3.2.7 Function not available with Custody Transfer Protection
4.9	COMM.MODULE	Submenu 4.9 Communication modules
4.9.1	PROTOCOL	Display of communication protocol fitted (OFF, SERIAL, HART, MODBUS, PROFIBUS, FF BUS or KROHNE)
4.9.2	ADDRESS	Address (not available for selection OFF and SERIAL in Fct. 4.9.1)
4.9.3	BAUDRATE	Setting Baudrate (for option MODBUS in Fct. 4.9.1 only)
4.9.4	SER.FORMAT	Serial format (for option MODBUS in Fct. 4.9.1 only)
4.10	CALIB I	Submenu 4.10 Calibration current output 1
4.10.1	I 1 5 mA	Calibration of the current output 1 for 5 mA
4.10.2	I 1 18 mA	Calibration of the current output 1 for 18 mA
4.10.3	I 2 5 mA	see I 1 5 mA
4.10.4	I 2 18 mA	see I 1 18 mA
4.10.5	I 3 5 mA	see I 1 5 mA
4.10.6	I 3 18 mA	see I 1 18 mA

Fct. No	Text	Description and settings
5	FACTORY.SET	Main menu 5 Factory settings
5.1	CALIBRATED	Submenu 5.1 Calibration values
5.1.1	CF1	Display of transducer calibration coefficients 5.1.11(Read only)
5.1.2	CF2	
5.1.3	CF3	
5.1.4	CF4	
5.1.5	CF5	
5.1.6	CF6	
5.1.7	CF7	
5.1.8	CF8	
5.1.9	CF9	
5.1.10	CF10	
5.1.11	CF11	
5.1.12	CF12	
5.1.13	CF13	
5.1.14	CF14	
5.1.15	CF15	
5.1.16	CF16	
5.1.17	CF17	
5.1.18	CF18	
5.1.19	CF19	
5.1.20	CF20	
5.1.21	METER CORR.	Input of a meter correction factor
5.2	METER	Submenu 5.2 meter data
5.2.1	METER TYPE	Display the meter type
5.2.2	METER SIZE	Display the meter size
5.2.3	MATERIAL	Display the measuring tube material
5.2.4	TUBE AMP	Display of the tube amplitude in percent
5.3	TEMP.LIMITS	Submenu 5.3 Temperature limits
5.3.1	MAX. TEMP.	Display the maximum allowed temperature
5.3.2	MIN. TEMP.	Display the minimum allowed temperature
5.4	TEMP. HIST.	Submenu 5.4 Temperature history
5.4.1	MAX. TEMP.	Display the maximum recorded temperature
5.4.2	MIN. TEMP.	Display the minimum recorded temperature
5.5	SERIAL NO.	Submenu 5.5 Serial numbers
5.5.1	BACKEND	Display the Backend serial number
5.5.2	FRONTEND	Display the Frontend serial number
5.5.3	METER	Display the meter serial number
5.5.4	SYSTEM	Display the system serial number

4.5 Reset / Quit Menu - Totalizer reset and status indication acknowledgement

Totalizer reset

Button	Display	Description
	10.36 kg	Measurement mode
↵	Code 2 —	Enter access Code 2 for reset/quit menu: ↑ →
↑ →	RESET.TOTAL	Totalizer reset menu If the additional totaliser is selected (Fct. 3.1.6) a choice of reset options is presented: * RESET ALL Reset all totalisers * ADDITIONAL Reset only the additional totaliser Otherwise the following is presented: * SURE YES * SURE NO Note: The reset option can be disabled by Fct. 3.5.3 or Custody Transfer (CT) lock.

View status message(s) and quit

Button	Display	Description
	0.36 kg/min ▽	Measurement mode The presence of the ▽ marker above Status on the display indicates the presence of warning messages in the status list.
↵	Code 2 — ▽	Enter access code for reset/quit menu: ↑ →
↑ →	RESET.TOTAL ▽	Totalizer reset menu.
↑	STATUS.LIST ▽	View/Quit Status message menu
→	MASS FLOW ▽	Use either the ↑ or → keys to view other messages in the list. Otherwise press ↵ to exit.
→	QUIT YES ▽	At the end of the message list the QUIT YES prompt is shown. Selecting YES will clear if possible messages in the list. To cancel the operation press ↑ to get QUIT NO and then press ↵.
↵	STATUS.LIST	Assuming the conditions that caused the message have passed (i.e. mass flow is back within the meter's range) then the Status marker, ▽ will disappear.
↵		Returns to measuring mode.

An overview with typical status messages and descriptions will be given in the table in chapter 6.2.

View FE Status

Button	Display	Description
↵	Code 2 —	Enter access code for reset/quit menu: ↑ →
↑ ↑	RESET.TOTAL STATUS.LIST FE STATUS	Totalizer reset menu. View/Quit Status message menu View FE Status messages
→	Messages	Normally no messages are present. Further messages are sometimes present which indicate the various diagnostic indicators, primarily for service or trouble shooting purposes.

5 Description of Functions

In all the following examples, a short notation is used for the setting of the signal converter. Pushing a key several times is indicated by the number of times without the intermediate display messages. Only the final display output is listed.

5.1 Menu 1 - Initial Start up

Zero Point Adjustment Fct. 1.1

When operating the system for the first time, it is necessary to set the zero point of the instrument.

Once the zero point has been adjusted, the installation should not undergo any further modifications in order to maintain the quality of the measurement. This means that after system changes (such as the piping or changing the calibration factor), it is advisable to re-adjust the zero-point.

To achieve a successful zero calibration the primary head should be completely full of process fluid at normal operating pressures and temperatures. Ideally there should be no air inclusions in the fluid, particularly for horizontal installations, so it is recommended that the primary head be flushed with the process fluid at a high flow rate (>50%), for 2 minutes, prior to starting the adjustment. After flushing, flow in the primary head must be brought back to zero by tightly closing appropriate valves.

The zero off-set can either be measured automatically or entered manually using the display keys. If an automatic adjustment is to be made then the operator should trigger this, with the front cover still in place, using the bar magnet provided to operate the magnetic sensors on the display. This is to ensure that the zero adjustment is carried out with the mechanical installation exactly the same as for normal operation.

Begin from the measuring mode.

Key	Display
→ x 2	Fct. 1.(1) ZERO CALIB.
→	Fct. 1.1.(1) AUTO CALIB.
↑	or Fct. 1.1.(2) MAN CALIB.



Note :

The brackets around parts of the above text indicates the cursor position, these characters will be flashing on the display. Flashing values can now be changed with the ↑ key. Pressing the → key moves the cursor to the next "field" which then starts to flash.

The operator can now choose either A) Automatic (recommended) or B) manual adjustment.

A) Automatic adjustment::

Key	Display
	Fct 1.1.(1) AUTO CALIB
→	SURE (YES)
↵	X.XXX PERCENT*
↵	ACCEPT (YES)
4x↵	Return to measuring mode.

* Display of actual flow rate % of maximum value, for a period of 30 seconds.

B) Manual adjustment:

Key	Display
	Fct. 1.1.(2) MANUAL CALIB.
→	(+)0.0000000 g/sec
Input value using ↑ to change sign and digit and → to move cursor.	
5x↵	Return to measuring mode.

Under certain conditions, it may not be possible to adjust the zero point, for instance when:

- The medium is in motion, because the shut-off valves etc. are not functioning properly.
- There are still gaseous inclusions in the primary head because it was flushed insufficiently.

In such cases the zero point adjustment will not be accepted. If the zero adjustment was started by the binary input, the converter will show the message :

ZERO.ERROR

The converter also reports the ZERO.ERROR in the status list.

Under certain circumstances, when the media consists of unevenly mixed components, it might be difficult to adjust the zero point. In such a case, the zero point adjustment procedure must be carried out under special conditions:

- Media which tend to vaporise or degas should be kept under higher pressure.
- Two-phase media consisting of a separable solid component (slurry): In such a case it might be advisable to fill the primary head with the carrier medium only.
- Other two-phase media.

If it is not possible to separate the solid or gaseous components, the operator can fill the measuring system with a substitute liquid (e.g. with water).

Instrument State Fct. 1.2.

The instrument may be switched to a 'STANDBY' state. Once in this state, all outputs go to their off state and the mass totaliser is frozen. The main display will have the STANDBY indicator set and will display either the frozen totaliser or just STANDBY.

Begin from measuring mode

Key	Display	
	Line 1	Line 2
		STANDBY
↑	3.456	kg (Frozen Totalizer)
↑		STANDBY

Whilst in this state the measuring tube still vibrates and the measurements can come back on line in an instant.

There is an additional standby state, 'STOP', in this case the drive to the primary head is disabled and vibrations cease. However, when leaving STOP the converter has to return to STARTUP before measurements can resume.

The instrument can be switched to STANDBY or STOP either by the keys on the display or by the control input signal (see section 5.4). STOP can only be set by the keys.

To set STANDBY or STOP:
Begin from measuring mode

Key	Display	
	Line 1	Line 2
→ x 2	Fct. 1.(1)	ZERO CAL.
↑	Fct. 1.(2).	INST. STATE
→		MEASURE
↑		(STANDBY)
↑		(STOP)
	Use the ↑ key to select the desired mode.	
↵	Fct. 1.(2)	STANDBY

If STANDBY or STOP was selected the instrument goes immediately into that state.

To return to measurement, go back to Fct. 1.2 and select MEASURE.

**Note:**

When changing from STOP into STANDBY the instrument will run through the STARTUP mode.

In addition to these 'standby' modes the SYSTEM CONTROL function provides a fully automated way of switching to similar modes using either the density or temperature of the process fluid as a control (see submenu 4.8).

Density Calibration Fct. 1.3

Calibrating the points can only be done when product is in the meter.

The two samples that the density has been calibrated at can be seen in the menu 1.3.1 for point 1 'DISP PT 1' and 1.3.2 'DISP PT 2' for point 2.

If the product was air, pure water or town water then the product name will be displayed.
If the product type was 'other' the density will be shown in the units that the density was entered at calibration time.

Factory Calibration

This enables the user to recall the factory calibration settings.

- Menu 1.3.5 FACTORY.SET
- Enter the menu
- Sure Yes/No
- Yes displays please wait while the calibration is restored.
- CALIB OK or CALIB FAIL is then displayed.

One Point Calibration

Menu 1.3.3 '1 POINT CAL' - This does not allow the user to decide which point to move; the converter decides the most appropriate point to move. The user chooses the product type that is in the meter and moves the best point.

The choices are Air, Pure water, Town water and Other.

If "Other" is selected, the product density needs to be entered. You can enter the density in any of the normal density units.

If you select 'pure water', 'air' or 'town water' the density does not need to be entered.

Once selected PLEASE WAIT is displayed.

Density calibration should take about 1 second.

After this time the result of the calibration will be displayed.

CALIB OK - the point has been entered correctly.

To see which point has been changed go to menu 1.3.1 'DISP PT1' and 1.3.2 'DISP PT2'.

CALIB FAIL - the density calibration failed. There are a number of causes for this:

1. Not in measuring mode
2. The 2 points are too close
3. The 2 points fail a plausibility check

Normally a 1 point calibration is adequate for most density calibrations e.g. tailoring the density to the new installation.

The 1 point calibration can be done twice, with two different products to achieve a 2 point calibration.

However, there is no guarantee that the first point is entered will not be moved when the second point is entered. In this case, it is better to use the two point calibration method.

Two Point Calibration

This is when the user wants to enter 2 set points.

The 2 point calibration makes sure that the 2 points entered by the user are used.

Warning - 2 point calibration will restore the factory calibration data before calibrating the 1st point.

Menu 1.3.4 '2 POINT CAL'

Sure Yes/No

First (1st) Entered Sample

Option: CAL Sample 1

Exit - Do not calibrate and exit (Does not change the calibration details)

CAL Sample 1

This gives you a choice of the following products air, pure water, town water and other.

Enter the product that is in the meter.

PLEASE WAIT will be displayed.

Response CALIB OK or CALIB FAIL.

Once saved, the meter can be switched off and it will remember that point 1 of a 2 point calibration has been entered.

Once the first sample has been entered successfully the next time menu 1.3.4 '2POINT CAL' is entered new options are available.

CAL Sample 2

Options:

CAL SAMPLE 2 - Enter the second calibration sample.

RESTART - Restart allows the user to re enter sample 1, see 1st entered sample.

EXIT

Enter the sample type as previously described.

Once complete and CALIB OK is displayed then the 2 point density calibration has been completed.

Density of water as a function of temperature

Temperature in		Density in	
°C	°F	kg/m ³	lb/ft ³
0	32	999.8396	62.41999
0.5	32.9	999.8712	62.42197
1	33.8	999.8986	62.42367
1.5	34.7	999.9213	62.42509
2	35.6	999.9399	62.42625
2.5	36.5	999.9542	62.42714
3	37.4	999.9642	62.42777
3.5	38.3	999.9701	62.42814
4	39.2	999.9720	62.42825
4.5	40.1	999.9699	62.42812
5	41	999.9638	62.42774
5.5	41.9	999.9540	62.42713
6	42.8	999.9402	62.42627
6.5	43.7	999.9227	62.42517
7	44.6	999.9016	62.42386
7.5	45.5	999.8766	62.42230
8	46.4	999.8482	62.42053
8.5	47.3	999.8162	62.4185
9	48.2	999.7808	62.41632
9.5	49.1	999.7419	62.41389
10	50	999.6997	62.41125
10.5	50.9	999.6541	62.40840
11	51.8	999.6051	62.40535
11.5	52.7	999.5529	62.40209
12	53.6	999.4975	62.39863
12.5	54.5	999.4389	62.39497
13	55.4	999.3772	62.39112
13.5	56.3	999.3124	62.38708
14	57.2	999.2446	62.38284
14.5	58.1	999.1736	62.37841
15	59	999.0998	62.37380
15.5	59.9	999.0229	62.36901
16	60.8	998.9432	62.36403
16.5	61.7	998.8607	62.35887
17	62.6	998.7752	62.35354
17.5	63.5	998.6870	62.34803
18	64.4	998.5960	62.34235
18.5	65.3	998.5022	62.33650
19	66.2	998.4058	62.33047
19.5	67.1	998.3066	62.32428
20	68	998.2048	62.31793
20.5	68.9	998.1004	62.31141
21	69.8	997.9934	62.30473
21.5	70.7	997.8838	62.29788
22	71.6	997.7716	62.29088

Temperature in		Density in	
°C	°F	kg/m ³	lb/ft ³
22.5	72.5	997.6569	62.28372
23	73.4	997.5398	62.27641
23.5	74.3	997.4201	62.26894
24	75.2	997.2981	62.26132
24.5	76.1	997.1736	62.25355
25	77	997.0468	62.24563
25.5	77.9	996.9176	62.23757
26	78.8	996.7861	62.22936
26.5	79.7	996.6521	62.22099
27	80.6	996.5159	62.21249
27.5	81.5	996.3774	62.20384
28	82.4	996.2368	62.19507
28.5	83.3	996.0939	62.18614
29	84.2	995.9487	62.17708
29.5	85.1	995.8013	62.16788
30	86	995.6518	62.15855
30.5	86.9	995.5001	62.14907
31	87.8	995.3462	62.13947
31.5	88.7	995.1903	62.12973
32	89.6	995.0322	62.11986
32.5	90.5	994.8721	62.10987
33	91.4	994.7100	62.09975
33.5	92.3	994.5458	62.08950
34	93.2	994.3796	62.07912
34.5	94.1	994.2113	62.06861
35	95	994.0411	62.05799
35.5	95.9	993.8689	62.04724
36	98.6	993.6948	62.03637
36.5	97.7	993.5187	62.02537
37	98.6	993.3406	62.01426
37.5	99.5	993.1606	62.00302
38	100.4	992.9789	61.99168
38.5	101.3	992.7951	61.98020
39	102.2	992.6096	61.96862
39.5	103.1	992.4221	61.95692
40	104	992.2329	61.94510
40.5	104.9	992.0418	61.93317
41	105.8	991.8489	61.92113
41.5	106.7	991.6543	61.90898
42	107.6	991.4578	61.89672
42.5	108.5	991.2597	61.88434
43	109.4	991.0597	61.87186
43.5	110.3	990.8581	61.85927
44	111.2	990.6546	61.84657
44.5	112.1	990.4494	61.83376

Temperature in		Density in	
°C	°F	kg/m ³	lb/ft ³
45	113	990.2427	61.82085
45.5	113.9	990.0341	61.80783
46	114.8	989.8239	61.79471
46.5	115.7	989.6121	61.78149
47	116.6	989.3986	61.76816
47.5	117.5	989.1835	61.75473
48	118.4	988.9668	61.74120
48.5	119.3	988.7484	61.72756
49	120.2	988.5285	61.71384
49.5	121.1	988.3069	61.70000
50	122	988.0839	61.68608
50.5	122.9	987.8592	61.67205
51	123.8	987.6329	61.65793
51.5	124.7	987.4051	61.64371
52	125.6	987.1758	61.62939
52.5	126.5	986.9450	61.61498
53	127.4	986.7127	61.60048
53.5	128.3	986.4788	61.58588
54	129.2	986.2435	61.57118
54.5	130.1	986.0066	61.55640
55	131	985.7684	61.54153
55.5	131.9	985.5287	61.52656
56	132.8	985.2876	61.51150
56.5	133.7	985.0450	61.49636
57	134.6	984.8009	61.48112
57.5	135.5	984.5555	61.46580
58	136.4	984.3086	61.45039
58.5	137.3	984.0604	61.43489
59	138.2	983.8108	61.41931
59.5	139.1	983.5597	61.40364
60	140	983.3072	61.38787
60.5	140.9	983.0535	61.37203
61	141.8	982.7984	61.35611
61.5	142.7	982.5419	61.34009
62	143.6	982.2841	61.32400
62.5	144.5	982.0250	61.30783

Temperature in		Density in	
°C	°F	kg/m ³	lb/ft ³
63	145.4	981.7646	61.29157
63.5	146.3	981.5029	61.27523
64	147.2	981.2399	61.25881
64.5	148.1	980.9756	61.24231
65	149	980.7099	61.22573
65.5	149.9	980.4432	61.20907
66	150.8	980.1751	61.19233
66.5	151.7	979.9057	61.17552
67	152.6	979.6351	61.15862
67.5	153.5	979.3632	61.14165
68	154.4	979.0901	61.12460
68.5	155.3	978.8159	61.10748
69	156.2	978.5404	61.09028
69.5	157.1	978.2636	61.07300
70	158	977.9858	61.05566
70.5	158.9	977.7068	61.03823
71	159.8	977.4264	61.02074
71.5	160.7	977.1450	61.00316
72	161.6	976.8624	60.98552
72.5	162.5	976.5786	60.96781
73	163.4	976.2937	60.95002
73.5	164.3	976.0076	60.93216
74	165.2	975.7204	60.91423
74.5	166.1	975.4321	60.89623
75	167	975.1428	60.87816
75.5	167.9	974.8522	60.86003
76	168.8	974.5606	60.84182
76.5	169.7	974.2679	60.82355
77	170.6	973.9741	60.80520
77.5	171.5	973.6792	60.78680
78	172.4	973.3832	60.76832
78.5	173.3	973.0862	60.74977
79	174.2	972.7881	60.73116
79.5	175.1	972.4890	60.71249
80	176	972.1880	60.69375

5.2 Menu 2 – Functional Checks

Menu 2.0. contains a number of test functions. These allow the current, frequency and alarm outputs to be driven at a number of fixed test levels, so that the communication between the converter and the customer's equipment can be verified. In addition, other functions allow various measured parameters from the primary head to be viewed directly for trouble shooting purposes.

Testing the display Fct. 2.1

This function sends a test sequence to the LCD display which causes each element of the display to be lit in sequence. If any segments fail to light, this indicates that the display is faulty and should be replaced.

Begin from measuring mode.

Key	Display	
	Line 1	Line 2
→↑	Fct. (2).	TEST
→	Fct. 2.(1)	DISPLAY
→		SURE (NO)
↑		SURE (YES)
↵	Display starts test sequence. All segments are lit and flashing	

The test may be terminated at any time by pressing the ↵ key.

Testing current output 1. Fct 2.2

This function allows a number of fixed current levels from 0...22 mA to be driven from the current output. This function interrupts the normal operation of the output, so the operator will be asked if he is sure before the test commences.

Key	Display	
	Line 1	Line 2
→↑	Fct. (2).	TEST
→↑	Fct. 2.(2)	Cur.out.1
→		SURE (NO)
↑		SURE (YES)
↵		(0 mA) 0 mA is output
↑		(2 mA)
↑		(4 mA)
↑		(12 mA)
↑		(16mA)
↑		(20 mA)
↑		(22 mA)
↑		(0 mA)

Press the ↵ key at any time to stop the test and return the output to normal operation.



Note:

Test points 0 mA and 2 mA not available on MFC 051 Converter

Systems with two or three current outputs Fct. 2.3 and 2.4

The same procedure is used to test current outputs 2 and 3 if fitted. Current output 2 is in Menu 2.3 and current output 3 is in menu 2.4.

Testing the pulse output Fct. 2.5

To test the pulse output, connect an external counter to the output terminals. When testing the pulse output, the operator has the choice of the following pulse widths: 0.4 ms, 1.0 ms, 10.0 ms, 100.0 ms and 500 ms.

The operator should choose the pulse width that best matches the performance of his external pulse counter.

Connect a pulse counter to the impulse output and proceed as follows:

Key	Display	
	Line 1	Line 2
→↑	Fct. (2)	TEST
→	Fct. 2.(1)	DISPLAY
↑ x 4	Fct. 2.(5)	Pulse out
→		SURE (NO)
↑		SURE (YES)
↵		Select pulse width with ↑ key
↵	Start test pulse output	

The meter now issues a stream of pulses with the set width. The running total of pulses sent is shown on the display. The test stops when either 100,000 pulses have been sent or the operator presses the ↵ key. A connected counter will now count. Press ↵ to stop the counting. The meter display and counter should have matching totals.

If the counter reads a smaller number than the actual number of pulses sent, or the frequency meter under reads, then this indicates that a weak signal is reaching the frequency meter/pulse counter. In this case try the following suggestions:

- Decrease the external pull-up resistor
- Decrease/remove the filter capacitor.
- Decrease the cable length between the converter and the counter.
- Add external buffers to boost the signal.

If the pulse counter reads a larger number than the converter, or if the frequency meter reading is high or unstable, then this indicates the presence of external interference. Try one or more of the following:

- Add/increase the size of the filter capacitor. (10...100nF)
- Use high quality screened cable.
- Keep cable lengths as short as possible, avoiding high power equipment/switchgear and any cabling connected to them.
- Use external buffers.

Testing the Frequency Output Fct. 2.6

This function allows the frequency output to be tested. The Frequency output has an open collector transistor drive which requires a pull-up resistor to an external DC power supply. To test the frequency, connect a frequency counter to the output terminals and proceed as follows:

Key	Display	
	Line 1	Line 2
→↑	Fct. (2)	TEST
→	Fct. 2.(1)	DISPLAY
↑ x 5	Fct. 2.(6)	Freq. out
→		SURE (NO)
↑		SURE (YES)
↵		(Level Low) 0V on the output
↑		(Level High) +24V on the output
↑		1 Hz
↑		10 Hz
↑		100 Hz
↑		1000 Hz
A frequency counter connected to the output will show these frequencies in steps.		
↵	Return to Fct. 2.(6)	

Testing alarm output Fct. 2.7

This is a simple function that allows the alarm output to be tested at both its high and low states.

Key	Display	
	Line 1	Line 2
→↑	Fct. (2)	TEST
→	Fct. 2.(1)	DISPLAY
↑ x 6	Fct. 2.(7)	Alarm out
→		SURE (NO)
↑		SURE (YES)
↵		(Level Low) 0V on the output
↑		(Level High) +24V on the output *
↵	Fct. 2.(7)	Alarm out

* Actual voltage depends on supply if using a PASSIVE status output

Testing control input Fct. 2.8

This function allows the state of the control input signal to be tested.

Key	Display	
	Line 1	Line 2
	Fct. 2.(7)	Alarm out
↑	Fct. 2.(8)	Control inp.
→		SURE (NO)
↑		SURE (YES)
↵	Level HIGH or LOW depending on input voltage	
↵	Fct. 2.(8)	Control inp.

Line 2 of the display shows the current state of the input.

- HIGH = 4...24 Volts,
- LOW = 0...2 Volts.

As the voltage on the input changes so the display will change from HIGH to LOW accordingly. However, whilst using the test function no action will be taken in response to the input (i.e. the total will not be reset).



Note:

If the input is disconnected it will read LO

Viewing sensor signal conditions – Diagnose Fct. 2.9

Menu 2.9 allows the viewing of eight parameters

Key	Display	
	Line 1	Line 2
	Fct. 2.9	Diagnose
↑	Fct. 2.9.1	
This displays the temperature of the measuring tube. By pressing the → key, the temperature will be indicated. By pressing the ↵ key, you will be returned to the Function display.		
↑	Fct. 2.9.2	Strain M. T.
This displays the strain value of the measuring tube strain gauge in ohms (where fitted).		
↑	Fct. 2.9.3	Strain I. C.
This displays the strain value of the inner cylinder strain gauge in ohms (where fitted).		
↑	Fct. 2.9.4	Tube Freq.
This displays the current resonant frequency of the sensor. This value is primarily used to calculate the density of the process fluid.		
↑	Fct. 2.9.5	Drive energy
This value indicates the current to the driver in percent. The heavier the fluid, the higher the number. Air entrainment also shows up as a higher number.		
↑	Fct. 2.9.6	Sensor A
↑	Fct. 2.9.7	Sensor B
These display the sensor signal level. Should be as per Menu 5.2.4, and be within 2% of each other.		
↑	Fct. 2.9.8	Comm.Errors
This displays the number of serial communication errors between the Front End (sensor mounted) and the converter electronics since power up. Normally displays 0		

Viewing hardware and software versions fitted Fct. 2.10

Menu 2.10 allows the viewing of the hardware and software versions installed in the mass flowmeter.

Key	Display	
	Line 1	Line 2
	Fct. 2.10	Versions
→	Fct. 2.10.1	Backend SW
This displays the software version in the converter MFC 050/051		
→	Fct. 2.10.2	Backend HW
This displays the hardware version of the converter MFC 050/051		
→	Fct. 2.10.3	Frontend SW
This displays the software version installed in the front end electronics mounted on the sensor.		

5.3 Menu 3- Configuration Menu

To access this menu, enter programming mode

Key	Display	
	Line 1	Line 2
→	Fct. 1	Operation
↑	Fct. 2	Test
↑	Fct. 3	Config.
→	Fct. 3.1	Basic Param.
→	Fct. 3.1.1	Low Flow cut off

Low Flow Cut Off Fct. 3.1.1

If the flow mode in (Fct. 3.1.3. is set to Flow +/- then at zero flow small signal fluctuations will average out to nothing and the totaliser will remain static.

However, if 'unidirectional' flow is selected, this process will not work and the totaliser reading will increment slowly with time. To prevent this, the Low Flow cut off should be set.

The Low Flow cut off is entered as a percentage of the rated nominal flow of the primary head. The cut off may be set from 0 to 10% in increments of 0.1%. Thus for example a 7000 T25 (nominal flow 34500 kg/h or 1250 lbs/min) with a low flow cut off of 0.2%, any flow less than 69kg/hr or 2.5 lb/min will indicate zero on the display.

To set the low flow cut off to 1%:

Key	Display	
	Line 1	Line 2
From	Fct. 3.1.1	Low Flow cut off
→	(0)0.5	Percent
→	(0).5	Percent
→	(1).5	Percent
→	1.(5)	Percent
↑	Repeat till (0) then	
↵	to accept the value.	

Time Constant Fct. 3.1.2

Measurements taken from the sensor are digitally filtered to provide stable readings in the event of fluctuating flows. The degree of filtering also affects the response time of the reading due to rapid changes in the flow.

Short time constant:

- Fast response
- Fluctuating reading

Long time constant:

- Slow response
- Stable reading

The figure below shows the typical response of the measurement for varying time constants and a rapid change in flow.

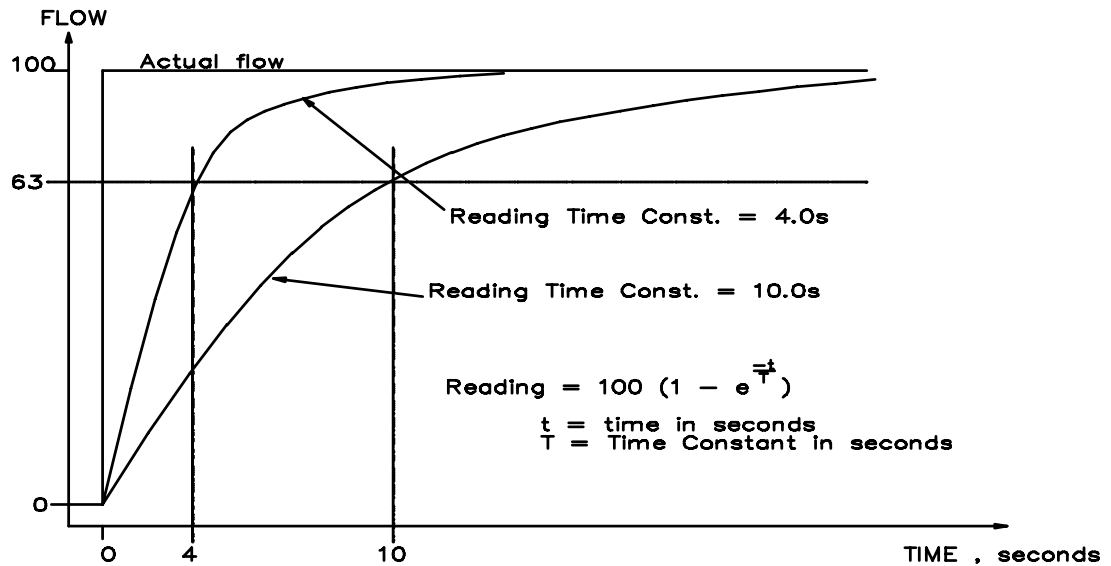

To set a time constant: e.g. 0.5 sec

Key	Display	
	Line 1	Line 2
From	3.1.(2)	Time. Const.
→	(0)0.3	Time. Const.
→	(0).2	Time. Const.
→	0.(2)	Time. Const.
↑	Repeat ↑ key till 5 is reached, then	
↵	to accept the value.	

The standard range for the time constant is 0.2...20 seconds.

The filtering only applies to mass and volume flow readings and any outputs programmed to these values. The mass totaliser, volume totaliser, density and temperature measurement outputs are independent of the programmed time constant.

Flow Mode Fct. 3.1.3

This setting allows the user to select the option of measuring flow in one direction only or in both directions.

To select the option required:

Key	Display	
	Line 1	Line 2
From	3.1.(3)	Flow mode
→	(Flow +/-)	default setting
The ↑ key allows the selection of one of the following:		
Flow>0 Ignores negative flows		
Flow<0 Ignores positive flows		
Flow +/- Allows positive and negative flows		
When the correct option is in the display the ↵ key may be pressed to accept the option.		



Note:

The totaliser will increment AND decrement if flow ± is selected according to the flow direction. Status options are available to indicate whether a reverse or forward flow is registered.

Flow direction Fct. 3.1.4

This function allows the user to select the direction of the flow measurement in relation to the arrows on the Front End housing. (see section 1.1 General Principles). 'Forward' is selected if the flow is in the same direction as the + arrow and 'Backward' if the flow is in the reverse or negative direction, i.e. same direction as the – arrow.

Note: if flow meter is installed in the line with the flow in the 'wrong' direction, this can be corrected by selecting the required direction for the measurement in this menu.

To select the option required:

Key	Display	
	Line 1	Line 2
From	3.1.(4)	Flow Dir.
→	(FORWARD) or 'BACKWARD' can be selected using the ↑ key	
When the correct option is in the display the ↓ key may be pressed to accept the option.		

Pipe diameter Fct. 3.1.5.

This function provides the user with an additional measurement of velocity. To provide this measurement, the pipe diameter of the measurement tube is required for the calculation. This value can be either the sensor tube internal diameter (default), or the internal diameter of the process pipe.

To set/check this value:

Key	Display	
	Line 1	Line 2
From	3.1.(5)	Pipe Diam.
→	e.g. 06.00	mm (default for 06 sensor)
This can be changed using the → the ↑ keys to change these values if not correct.		
When the correct option is in the display the ↓ key may be pressed to accept the option.		

The setting of the Velocity function to an output is described in Section 5.4 (Fct 4.2.1)

Additional Totaliser Fct. 3.1.6

An additional totaliser can be viewed on the display by allocating a function to it in this menu.

The options available are:

- None
- Mass Total
- Volume Total
- Conc. Total

To select an option:

Key	Display	
	Line 1	Line 2
From	3.1.(6)	Add. Total
→	(none)	
By using the ↑ key one of the options can be selected from the list.		
When the correct option is in the display the ↓ key may be pressed to accept the option.		

Error Messages Fct. 3.1.7

The menu allows the user to select which status message is to be displayed in the event of a malfunction. One of the following can be selected according to groups described in Section 7.2:

- Basic Errors
- Transducer Error
- I/O Errors
- All Errors

To select an option

Key	Display	
	Line 1	Line 2
From	Fct. 3.1.(7)	Error MSG
→	Basic Errors)	
By using the ↑ key one of the options can be selected from the list.		
When the correct option is in the display the ↓ key may be pressed to accept the option.		

Pressure Suppression Fct. 3.1.8 and 3.1.9

The Pressure Suppression feature eliminates any influences on the measurement result of sudden termination of flow, such as when a valve is shut. When this occurs the propagation of pressure waves along the pipe work and through the meter may produce an "Over-shoot" or "ringing" effect, where the flow rate will oscillate backwards and forwards until it settles to a stable zero flow condition, as is indicated in the diagram below. Typically this will only be noticeable on high pressure applications.

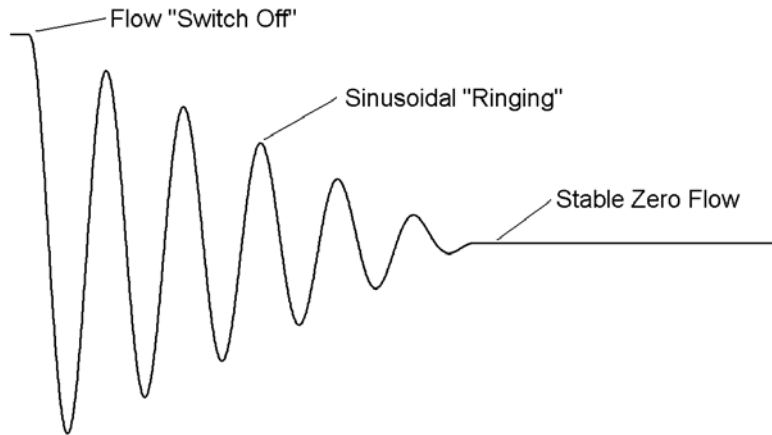

In most cases the amplitude of the ringing will be below the "Low Flow Threshold" and will therefore not influence the result. In some cases however the amplitude of the ringing is above the Low Flow Threshold and could contribute an error in the totaliser values.

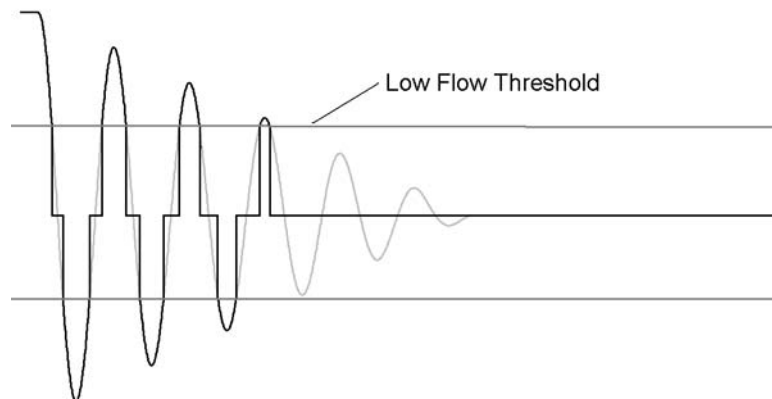

The pressure suppression function eliminates this effect, by increasing the Low Flow Cutoff for a short period of time, triggered when the flow first drops below the Low Flow Threshold. For a set time period (set in Fct. 3.1.8) the pressure suppression threshold (set in Fct 3.1.9) is added to the standard Low Flow Threshold (set in Fct. 3.1.1).

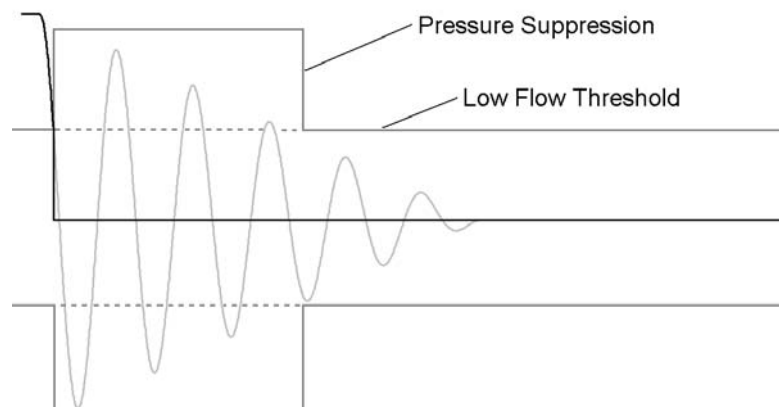

Settings of these parameters depend on actual process conditions and characteristics of the pipework and so can only be determined by experimentation in-situ.

Cyclic Display Fct. 3.2.1

The display can be programmed to cycle between all values or to remain static at the selected variable.

To select an option:

Key	Display	
	Line 1	Line 2
From	Fct. 3.2.1	Cycle Disp.
→	STATIC DISPLAY	
↑	CYCLE DISPLAY	
↑	STATIC DISPLAY	
Press ↵ to select the required option.		

Mass Flow Fct. 3.2.2

The units and the measurement resolution can be set in this menu.

Key	Display	
	Line 1	Line 2
From	Fct. 3.2.2	Mass Flow.
→	00000.000	(kg) / min
↑	Changes the eng. units selectable kg, t, oz, lb, g.	
When unit selected press → to select time base. kg / (min)		
↑	Changes the time units selectable min, hr, day, sec.	
When time unit selected press → . This will now allow the selection of the decimal position.		
Press ↑ to select the decimal position.		
When selection complete press ↵.		

Mass Total Fct. 3.2.3

This menu allows the setting of the units for the mass totalizer.

Key	Display	
	Line 1	Line 2
From	Fct. 3.2.3	Mass Flow.
→	00000.000	(kg)
The ↑ selects the units. Choose from kg,t,oz,lb,g.		
→	now allows the decimal position to be selected.	
↑	Shifts the decimal position.	
When selection complete press ↵.		

Volume Flow Fct. 3.2.4

Allows the selection of volume flow and the associated units.

Key	Display	
	Line 1	Line 2
From	Fct. 3.2.4	Volume Flow.
→		(off) – default is off.
↑	00000.000	(cm ³)/sec
↑	Selects the units. Selection of cm ³ , dm ³ , litre, m ³ , in ³ , ft ³ , US gal, Impgal, off.	
→	Allows the setting of the time base. Selection of sec, min, hr, day.	
When selection complete press ↵.		

Volume Total Fct. 3.2.5.

Parameters for the volume totalizer are selected in this menu.

Key	Display	
	Line 1	Line 2
From	Fct. 3.2.5	Volume Tot.
→		(off) – default is off.
↑	Selects the totalizer display. 00000.000 (cm ³)	
↑	Selects the units. Selection of cm ³ , dm ³ , litre, m ³ , in ³ , ft ³ , US gal, Impgal, off.	
→	Allows the position of the decimal place to be changed.	
When selection complete press ↵.		

Temperature Fct. 3.2.6.

Selects the temperature units.

Key	Display	
	Line 1	Line 2
From	Fct. 3.2.6	Temperature.
→		°C.
↑	Selects units. Choose from °C, °F.	
↵	After selection	

Density Fct. 3.2.7

Allows the selection of density units and measurement resolution.

Key	Display	
	Line 1	Line 2
From	Fct. 3.2.7	Density.
→	00000.000	(kg)/m ³ .
↑	Allows the selection of the units. Choose from kg, t, oz, lb, SG, g.	
→	Selects the volume units to be changed. Choose from m ³ , in ³ , ft ³ , US gal, Impgal, cm ³ , dm ³ , litre.	
→	The decimal position can now be selected using the ↑ key.	
When selection complete press ↵.		

Concentration Flow Fct. 3.2.8.

The concentration option has to be activated to access this menu. When this option has not been ordered the words "Not Fitted" will appear in the display.

If this option was ordered, please refer to separate manual supplied with this option.

Concentration Total Fct. 3.2.9.

As per Fct. 3.2.8

The concentration total will be indicated by the letter "C" in the left corner of the display.

Concentration by mass Fct. 3.2.10.

As per Fct 3.2.8.

Concentration by Volume Fct. 3.2.11

As per Fct. 3.2.8.

Velocity: Fct. 3.2.12

This function provides an additional measurement parameter. This is particularly useful when the velocity of hazardous materials is to be monitored where static build up is a danger. The mass flow meter will calculate the velocity based on the tube diameter and the mass flow rate. In this menu the units for velocity may be selected.

Key	Display	
	Line 1	Line 2
From	Fct. 3.2.12	Velocity.
→		(off) - default
↑	Selects the velocity units. Choose from m/sec, ft/sec and off.	
↵	Accepts the selection.	

Language: Fct. 3.2.13

The language of choice may be selected from this menu.

Key	Display	
	Line 1	Line 2
From	Fct. 3.2.13	
→		Language
→		English
↑	Selects further languages. Choose from Francais, Espanol, Deutsch.	
↵	To select.	
Note: The language in the text will only change once you have exited the programming mode and accepted the changes.		

Concentration Measurement Fct. 3.3

Menu 3.3 is the Concentration menu.

If concentration has been ordered then please refer to the concentration manual, which will accompany the meter.

Density Mode Fct. 3.4.1

This menu allows the user to select the type or mode of the density measurement.

Key	Display	
	Line 1	Line 2
From	Fct. 3.4.1	Dens. mode
→		Actual
↑	Selects further options, e.g. Fixed – This is used for products where the fixed density is used for a volume calculation e.g. gas measurements. Referred – Used for applications where the mass or volume of a product is measured, referred to a base density.	
↵	Confirms the selection.	

Menu 3.5 Passwords

This menu contains all the settings to protect the configuration of the instrument from accidental or deliberate changes.

Key	Display	
	Line 1	Line 2
From	Fct. 3.5.1	Supervisor
→	By pressing this button Enable PW appears.	
↑	Selects further options, change PW or Exit.	

Enable password – press ↵.

- Code 1 will appear with 9 open segments below.
- Press a combination of → ↵ ↑ arrows as a pre-selected password.



Note:

Make a note of the sequence as once enabled and the password is forgotten, access to the programming mode will no longer be possible.

- Once the 9 keystrokes have been entered, ↵ confirms the password.
- Comms Yes will appear in the display.
- If comms are used the option can be selected for comms as well. If not required, select No using the ↑ key.
- After pressing ↵ PW Enabled will appear.
- Once you have exited the programming mode you will need to enter this password to access the programming mode again.

If the password is to be disabled, enter the programming mode using the password.

Key	Display	
	Line 1	Line 2
From	Fct. 3.5.1	Supervisor
→	Disable PW appears.	
↵	To input the original password.	

Once the original password has been entered, the words PW disabled appear. The password has now been disabled and once ↵ is pressed, the program reverts to the last step.

If the → is pressed or you are in the password menu Exit can be selected with the ↑ key and after pressing ↵ you will exit the menu.

A password can also be changed by selecting Change PW using the ↑ key.

Custody Fct. 3.5.2 (applicable to Custody Transfer meters only).

The same procedure as above can be used to enter a unique password to protect the meter ranges, pulse information etc to be changed in a Custody Transfer application.

This password is normally kept by the Fiscal authorities when such applications are tested and the meter is subsequently sealed.

Total Reset Fct 3.5.3

This function allows the user to select whether the totalizer may be reset or not, as well as to block or allow the reset function via a communication option if used.

Key	Display	
	Line 1	Line 2
From	Fct. 3.5.3	Total Reset
→	Allow reset.	
↑	Selects further options, comm reset or no reset allowed.	
After selection press ↵		
Note: If no reset is selected, the totalizer cannot be reset at all. (See section 4.1 for reset totalizer function).		

Menu 3.6 Settings

This menu allows a Tag or ID number to be programmed. A combination of alphanumeric characters is available.

Key	Display	
	Line 1	Line 2
From	Fct. 3.6.1	Tag ID
→	Allows the programming of a Tag number.	
The ↑ provides the selection of character required while the → allows the selection of the next character to be selected. When complete the ↵ button must be pressed.		

5.4 Menu 4 - I/O Configuration

The actual output configuration can be read out in Fct. 4.1 I.O. FITTED. The menu 4.1 is "Read only" for the output options 1, 2 and 3 of the MFC 050 converter and for all options for the MFC 051 converter.

For the output options 4 to 8 the user can select between the following configuration options:

Fct. 4.1 I/O Fitted

Key	Fct. 4.1. I.O. FITTED		
	2I A B	Option 4	(2 current op, 1 alarm op, 1 control ip)
	2I F B	Option 5	(2 current op, 1 pulse/frequency op, 1 control ip)
	3I F	Option 6	(3 current op, 1 pulse/frequency op)
	3I B	Option 7	(3 current op, 1 control ip)
	3I A	Option 8	(3 current op, 1 alarm op)

After every change of the output configuration in Fct. 4.1 all current outputs needs recalibration (see Fct. 4.10).

For the configuration of the input/outputs see chapter 4.4 "Table of programmable functions"

Current Output 1 - Menu 4.2

Function Fct. 4.2.1.

This menu allows the allocation of one of the following functions to the output current (first 4-20 mA).

Key	Fct. 4.2.1. Function	
	Off	No function allocated. No output.
	Mass flow	Process functions
	Density	Process functions
	Volume flow	Process functions
	Temperature	Process functions
	Direction	Process functions
	Sensor Ave.	(for diagnostic purposes)
	Sensor Dev.	(for diagnostic purposes)
	Drive Energy	(for diagnostic purposes)
	Tube frequency	(for diagnostic purposes)
	Strain MT	(for diagnostic purposes – strain on measuring tube)
	Strain IC	(for diagnostic purposes – strain on Inner cylinder)
	Velocity	Process functions

Once option is selected press ↵ to save.

Range Fct. 4.2.2.

This allows the setting of the measurement range of the output. Choose from the following:

Key	Fct. 4.2.2. Range	
	4-20 mA	
	4-20/2 mA	defaults to 2 mA in case of a fault.
	4-20/3.5 mA	defaults to 3.5 mA in case of a fault (required by some control systems).
	4-20/22 mA	defaults to 22 mA in case of a fault.
	0-20 mA	
	0-20/22 mA	defaults to 22 mA in case of a fault.

Low Limit Fct. 4.2.3.

This menu allows the selection of the units as well as the minimum value for the function chosen. Note that these units will change according to the function selected in Fct. 4.2.1.

High Limit Fct. 4.2.4.

As above but for the upper limit of the measured function.

Current Output 2 – Menu 4.3

If a second current output is fitted, the same functions as above will be available.

Current Output 3 – Menu 4.4

If a third current output is fitted, the same functions as above will be available.

Pulse / Frequency Output – Menu 4.5**Function Fct. 4.5.1.**

Allows the following functions to be set to the pulse / frequency output:

Key	Fct. 4.5.1.	
	Off	no output
	Mass flow	
	Density	
	Mass total	
	Volume flow	
	Volume total	
	Temperature	
	Direction	
	Velocity	
	Additional	(This is the second or additional totalizer in the display)

Frequency**Low Limit Fct. 4.5.2.**

This allows the selection of the units and the minimum value for the measurement.

High Limit Fct. 4.5.3.

This allows the selection of the units and maximum value for the measurement.

Max Frequency Fct. 4.5.4.

The maximum frequency range can be set (Maximum value is 1000 Hz).

Pulse**Pulse width Fct 4.5.2**

Sets the minimum pulse width.

Pulse Value Fct 4.5.3

Sets the value of each pulse e.g. 0.5kg per pulse.

Alarm Output – Menu 4.6**Function Fct. 4.6.1.**

Any one of the following may be programmed / selected for the alarm output.

Key	Fct. 4.2.1. Function	
	Off	no alarm function
	Mass flow	
	Density	
	Mass total	
	Volume flow	
	Volume total	
	Temperature	
	Direction	
	Severe Error	
	All Errors	
	I1 Sat.	(Current S/P 1 Saturated)
	I2 Sat.	(Current S/P 2 Saturated)
	I3 Sat.	(Current S/P 3 Saturated)
	Pulse Sat.	(Pulse output Saturated)
	Any op. Sat.	(Any output Saturated)
	Velocity	
	Additional	(The range for the additional / second totalizer Saturated)

Active Level Fct. 4.6.2.

Allows the selection of the alarm level. High or Low.
(Normally open or normally closed).
Active high or active low.

Control Input – Menu 4.7

This menu allows the setting of certain functions via an external input (contact or binary).

Function Fct 4.7.1

Choose one of the following:

Inactive	Option not required.
Standby	This option puts the meter into a standby mode where the tube is still vibrated, but the outputs are frozen to zero. Can be used for example during a cleaning process. Meter will resume measurement mode almost instantaneously once contact is removed.
Stop	This option stops the meter vibrating and shuts all the measurements down. When the contact is removed, the meter will go through its plausibility checks before resuming measurement mode. This will take a few seconds.
Zero Calib.	This option will initiate a zero calibration externally generated via a push button or a contact from a valve or pump.
Total Reset	Will allow the resetting of the totalizer remotely (the option in menu 3.5.3 needs to be enabled).
Quit errors	Allows the acceptance and quitting of errors remotely.

Active Level Fct. 4.7.2

This allows the contact to be high or low (normally open or normally closed) as before.

System Control – Menu 4.8

This menu allows the setting up of certain instrument functions depending on the selected process condition. If a pre-determined condition arises (as selected in Fct. 4.8.2) then one of the following options can be selected.

Function	Fct. 4.8.1.	
Key	Fct. 4.8.1.	
	Off	Function not activated
	Flow = 0	If process condition arises, flow outputs will be forced to zero.
	Flow = 0 / RST	Flow outputs are driven to zero and totalizer is reset.
	Outputs off	All outputs switched off.

Condition Fct. 4.8.2.

This menu allows the setting of the process condition for the instrument actions as described in Fct. 4.8.1.

The following can be selected:

- Density or
- Temperature

If one or the other is selected then the limits can be set up in the reset menu.

Low Limit Fct. 4.8.3.

The minimum value may be programmed here.

If density was selected then the value and units for density will appear. The same for temperature. The units will depend on what was selected in density or temperature measurement menus Fct 3.2.3 or 3.2.7.

High Limit Fct. 4.8.4.

The maximum limit for density or temperature can be programmed here. Similar to Fct. 4.8.3.

Communication Options – Menu 4.9

This menu is normally a read only menu. It indicates the communications protocol used by the converter.

Protocol Fct. 4.9.1.

This menu displays the communication protocol fitted.

Options available:

- Off – no options fitted
- Serial – Internal KROHNE service and calibration protocol
- HART®
- Modbus
- Profibus PA
- Foundation Fieldbus
- KROHNE – Proprietary KROHNE protocol.

Address Fct. 4.9.2.

The instrument address on the bus can be programmed here. This function is not active if off or Serial has been selected in Fct. 4.9.1.

When HART has been selected only point to point is available with the MFC 050. If the MFC 051 is used, point to point as well as multi drop is possible.

- For HART on MFC 050 the address is defaulted to 0.
- For HART on MFC 051 the selectable address is from 0 to 16.

Baud Rate Fct. 4.9.3.

Available for Modbus when selected in Fct. 4.9.1.

Note that Modbus is only available in the MFC 050.

Ser. Format Fct. 4.9.4.

For option Modbus only.

Calibration – Menu 4.10

This menu allows the calibration of the current outputs. This is always factory set before shipment. It only requires performing if any of the configuration for outputs, or output modules have been changed.

I1 5mA Fct. 4.10.1.

Injects 5 mA on the output terminals for the first current output.

I1 18mA Fct. 4.10.2.

Injects 18 mA on the output terminals for the first current output.

These values can be measured at the receiving instrument / control system and may be adjusted by pressing the → button again. The output may then be adjusted to read the correct amount at the receiving end. This adjustment can also be used to compensate for losses due to long cable runs.

For the second and third current outputs (if fitted) the calibration can be performed in Fct. 4.10.3. to Fct. 4.10.6.

5.5 Menu 5 - Factory Settings

This menu allows the user to view certain information relating to the meter. E.g. calibration co-efficients, meter type, size, serial numbers etc.

Fct. 5.1.1. through to Fct. 5.1.20. Read only transducer co-efficients.

Meter Corr. Fct. 5.1.21.

Correction factor if meter over or under reads in an application.

If under reading, add the required value in + percent in this menu.

If over reading, deduct the required percentage i.e. change sign to – and program the percentage error.

Meter (sensor) description and settings – Menu 5.2

From this menu the relevant data concerning the sensor is stored.

Meter Type Fct. 5.2.1.

Displays the meter type.

- OPTIMASS 7000. Single Straight Tube meter.
- OPTIMASS 3000. Single bent tube low flow meter. (7100)
- OPTIMASS 8000. Dual U-tube meter (Max 230°C)
- OPTIMASS 9000. Dual U-tube meter (Max 350°C)
- OPTIGAS 5000. Dual Omega tube for CNG filling stations

Meter Size Fct. 5.2.2.

- If OPTIMASS 7000 is displayed in Fct. 5.2.1. then one of the following sizes will be displayed (See tech. datasheet for flow rates etc): 06; 10; 15; 25; 40; 50; 80.
- If OPTIMASS 3000 is displayed in Fct. 5.2.1. then one of the following sizes will be displayed: 01; 03; 04.
- If OPTIMASS 8000 or 9000 is displayed in Fct. 5.2.1. then one of the following sizes will be displayed: 15; 25; 40; 80; 100.
- If OPTIGAS 8000 or 9000 is displayed in Fct. 5.2.1. then one of the following sizes will be displayed: 15; 25.

Material Fct. 5.2.3.

Displays the measuring tube material of the meter.

- OPTIMASS 7000. One of the following: Titanium, Hastelloy, Stainless Steel.
- OPTIMASS 3000. One of the following: Stainless Steel, Hastelloy.
- OPTIMASS 8000/9000. One of the following: Stainless Steel, Hastelloy, Titanium
- OPTIGAS 5000. Stainless Steel

Tube Amp. Fct. 5.2.4.

Displays the set tube amplitude in percent.

Temperature Limits – Menu 5.3

Fct. 5.3.1 and Fct. 5.3.2 displays the maximum and minimum allowable process temperatures the meter may be used for.

Temperature History – Menu 5.4

This menu allows the viewing of the maximum and minimum recorded temperature the meter has been exposed to.

- Menu 5.4.1 is the maximum temperature.
- Menu 5.4.2 is the minimum temperature.

Serial numbers – Menu 5.5

All the components that make up the complete instrument have individual serial numbers.

This menu displays the serial numbers of the individual components.

These serial numbers are mainly used for service purposes. The system serial number is the only serial number that is required when communicating with the factory.

Back end Fct. 5.5.1.

Displays the back end or main signal converter serial number.

Front end Fct. 5.5.2.

Displays the front end serial number.

Meter Fct. 5.5.3.

Displays the meter or sensor serial number.

System Fct. 5.5.4.

Displays the system serial number. This is the main serial number that is on the main data plate as well as on the calibration plate.

6 Service and Trouble Shooting

6.1 Diagnostic functions

The following diagnostic functions are available in the submenu Fct. 2.9 DIAGNOSE:

Temperature (menu 2.9.1):

- Displays temperature in either °C or °F. The value should be stable.

Strain (menu 2.9.2 Strain measuring tube / 2.9.3 Strain inner cylinder):

- Value of strain in Ohms. The values should be in the range stated in the table in chapter 7.3. Wildly unstable value even after temperature stabilisation: the strain gauge has possibly become delaminated due to the meter being operated over maximum temperature for prolonged periods of time (please contact KROHNE UK service department).

Frequency (menu 2.9.4):

- Variations in the first digit after the decimal point indicate gas or air in the fluid.
- Worn or eroded flow tube: frequency will increase by around 2...4 Hz meter requires re-calibration
- Coatings can also alter the frequency
- Large fluctuations are seen if the meter is in 'Start Up'

Drive energy (Energy level/menu 2.9.5):

Typical values for the drive energy level with water as process fluid and no included air or gas are:

OPTIMASS 3000: (7100)	all sizes:	0...4
OPTIMASS 7000 :	06...40 50...80	0...6 4...10
OPTIMASS 8000:	all sizes:	0...5
OPTIMASS 9000:	all sizes:	0...5

Higher drive energy levels can occur due to gas or air in the fluid or at the measurement of high viscous fluids or fluids with high densities.

Sensor A and B (menu 2.9.6 , 2.9.7):

The displayed value should be around:

- 80% for OPTIMASS 7000 – sizes 06 ... 40, OPTIMASS 8000, OPTIMASS 9000
- 60% for OPTIMASS 7000– sizes 50 and 80
- 55% for OPTIMASS 3000 (7100) all sizes

Or as per Amplitude setting Menu 5.2.4.

Sensor values should be within 2% of each other.

Communication errors (menu 2.9.8):

Display of the number of communication errors.

6.2 Error Messages

- Basic Errors: These errors are displayed independently of which error message function is selected.
- Transducer Errors: These errors only occur when error message function is set to TRANS.ERROR or ALL ERRORS
- I/O Errors: These errors only occur when TRANS.ERROR or ALL ERRORS is set to I/O Errors or All Errors
- All Errors: All errors can occur
- Errors are encoded as follows:

Bit	Error Name	Error definition	Error type	Error Level
0	MASS FLOW	Measured mass flow value over range	Basic error	Light
1	ZERO ERROR	Excessive flow measured during zero calibration	Basic error	Light
2	TOTAL O/F	Fixed precision totaliser has rolled over	Basic error	Light
3	Not used			
4	Temperature	Temperature is outside the operating ranges	Basic error	Light
5	Sensor A	Sensor A voltage signal is less than 5% of desired value	Transducer error	Light
6	Sensor B	Sensor B voltage signal is less than 5% of desired value	Transducer error	Light
7	Ratio A/B	One sensor signal is much larger than the other	Basic error	Severe
8	DC A	DC voltage part of sensor A is larger than 20% ADC	Basic error	Severe
9	DC B	DC voltage part of sensor B is larger than 20% ADC	Basic error	Severe
10	Not used			
11	Sampling	No synchronization with primary head	Basic error	Severe
12	Not used			
13	ROM DEFAULT	EEPROM checksum error detected on start up. Default data has been loaded.	Basic error	Severe
14	Not used			
15	EEPROM	Unable to save data to EEPROM. Hardware fault	Basic error	Fatal
16	NVRAM	Checksum error detected on startup. Previous data lost	Basic error	Severe
17	NVRAM FULL	NVRAM has exceeded 50,000 Cycles	Basic error	Fatal
18	POWER.FAIL	Custody transfer only. There has been an interruption of power to the converter.	Basic error	Light
19	Watchdog	Converter reset by the watchdog. Last NVRAM save failed.	Basic error	Fatal
20	Not used			
21	Temp Custody	Temperature has drifted by 30 degrees from the zero calibration temp	Basic error	Light
22	RESIST.CIR	Resistance circuit has failed	Basic error	Light
23	I 1 SAT.	Current output 1 is outside the set ranges	I/O Error	Light
24	FREQ SAT.	Frequency/pulse output is outside the set ranges	I/O Error	Light
25	ALARM.OUT.A	Alarm output is outside the set ranges	I/O Error	Light
26	I 2 SAT	Current output 2 is outside the set ranges	I/O Error	Light
27	I 3 SAT	Current output 3 is outside the set ranges	I/O Error	Light
28	COMM.FAIL	Communication failure > 5 attempts without valid response	Basic error	Severe
29	SYS Changed	The front end or backend do not match. (One has been changed)	Basic error	Light
30	SYSTEM	Converter reset	Basic error	Severe
31	Not used			

Errors on POWER UP

- WIRING ERROR : Incorrect wiring detected on remote meters
- FRONT END ERROR :

6.3 Functional Tests and Troubleshooting

Min. and Max. recorded temperature (menu 5.4):

Records the maximum values of temperature and strain as experienced by the transducer.

Max. operating temperature:		Maximum	Minimum
		OPTIMASS 7000 - Titanium	150°C or 302°F
	OPTIMASS 7000 - Hastelloy	100°C or 212°F	0°C or 32°F
	OPTIMASS 7000 – SS	100°C or 212°F	0°C or 32°F
	Optional	130°C or 266°F	
	OPTIMASS 3000 (7100) – SS or Hastelloy	150°C or 302°F	-30 °C or -22°F
	OPTIMASS 8000 * (Depending on variant)	230°C or 446°F	-180 °C or -292°F
	OPTIMASS 9000	350°C or 662°F	0°C or 32°F

Application problems that appear to be Transducer Faults

- Leaky Valves will cause high zeros
- Entrained Air/gas will cause high energy levels and high zero
- Product coating on the inside of the tube will cause high/low density and high zero

The following faults have occurred (listed below with their symptoms):



Beware:

Application problems can cause similar symptoms, check this first!

Tube bore slightly eroded or corroded

- Density Low
- Frequency High
- Small Mass Flow Errors

Tube eroded or corroded through (fluid in housing)

- Tube will not start
- If fluid conductive - low resistance to ground

Open Circuit Drivers, Sensors, RTD's and Strain Gauges

- Detectable with Ohm meter

Typical Frequency values (at 20°C / 68°F)

Model Size	Titanium		SS		Hastelloy	
	Empty	Water	Empty	Water	Empty	Water
3000 - 01			137 ± 3	133 ± 3	141 ± 3	137 ± 3
3000 - 03			137 ± 3	133 ± 3	141 ± 3	137 ± 3
3000 - 04			195 ± 5	185 ± 5	195 ± 5	185 ± 5
7000 - 06	316 ± 10	301 ± 10	374 ± 6	361 ± 7		
7000 - 10	402 ± 10	367 ± 10	419 ± 15	394 ± 15	439 ± 7	415 ± 6
7000 - 15	507 ± 7	436 ± 6	573 ± 15	514 ± 15	574 ± 27	517 ± 27
7000 - 25	619 ± 6	488 ± 6	701 ± 10	589 ± 10	693 ± 10	586 ± 10
7000 - 40	571 ± 6	415 ± 6	642 ± 10	509 ± 10	633 ± 6	506 ± 6
7000 - 50	539 ± 5	375 ± 5	550 ± 14	435 ± 14	582 ± 11	453 ± 11
7000 - 80	497 ± 5	349 ± 5	502 ± 10	378 ± 12	492 ± 12	369 ± 12
8/9000 – 15			146 ± 3	136 ± 3	146 ± 3	136 ± 3
8/9000 - 25			181 ± 3	162 ± 3	181 ± 3	162 ± 3
8/9000 - 40			192 ± 3	164 ± 3	192 ± 3	164 ± 3
8/9000 - 80			119 ± 3	101 ± 3	119 ± 3	101 ± 3
8/9000 - 100			149 ± 3	117 ± 3	149 ± 3	117 ± 3

Zero Problems

- Perform auto zero, observe the displayed value, it should be stable and lower than +/- 0.5%
- If the result is bad:
Stop flow, set 3.1.1 Low flow cut off to 0, 3.1.3 Flow Mode to "+/-", perform auto zero, and totalise over 2 minutes. Compare totalised flow to specified zero stability.

For best process results, zero setting should be performed on process fluid at process temperature.

High Zero's can be caused by: Leaking valves, Air/Gas inclusions, Coating on tube.

Driver or Sensor Coil Fault

Typical inductance and resistance values:

OPTIMASS 7000

OPTIMASS 7000	Inductance (mH)		Resistance (Ohm)	
	Driver	Sensor A/B	Driver	Sensor A/B
06/10	5.30 (4.32)	17.32 (10.36)	37 - 42	147 - 152
15	11.7 (8.9)	17.32 (10.36)	47 - 51	147 - 152
25/40	13.1 (11.3)	17.32 (10.36)	40 - 41	147 - 152
50/80	23.5 (12.9)	17.32 (10.36)	49 - 51	147 - 152

- The above data are provided as a rough guide only.
- Damaged magnet coil assembly: Inductance values in brackets.
- Driver = Black and Grey.
- Sensor A = White and Yellow. Sensor B = Green and Purple.
- RTD = Red and Blue (530...550 Ω) at ambient temperature
- Tube strain = Red and Brown:
OPTIMASS 7000 – 06 600 - 800 Ω at ambient
OPTIMASS 7000 – 10...80 420 - 560 Ω at ambient
- IC strain = Brown and Orange OPTIMASS 7000 – 06...10 225 - 275 Ω at ambient
OPTIMASS 7000 – 15...80 Not fitted
- Resistance values outside these values could indicate a circuit failure. Meter may be in start-up or have measuring errors.
- All circuit should be isolated from ground (meter case) and each other: >20M Ω . If circuits are shorting to ground, meter may be in start-up.



Caution:

Fluid may be in secondary containment – possible tube failure. Depressurise and safely remove from line as soon as possible.

OPTIMASS 3000 (7100)

OPTIMASS 3000 (7100)	Inductance (mH)		Resistance (Ohm)	
	Driver	Sensor A/B	Driver	Sensor A/B
01	1.2 (1.2)	7.2 (7.2)*	54 – 60	105 - 110
03/04	2.6 (8.9)	10.5 (10.36)	43 – 50	132 - 138

- The above data are provided as a rough guide only.
- Damaged magnet coil assembly: Inductance values in brackets.
- Driver = Purple/Black and Orange/Grey.
- Sensor A = White and Yellow. Sensor B = Green and Yellow.
- RTD = Red and Blue (530...550 Ω) at ambient temperature
- Resistance values outside these values could indicate a circuit failure. Meter may be in start-up or have measuring errors.
- All circuit should be isolated from ground (meter case) and each other: >20M Ω . If circuits are shorting to ground, meter may be in start-up.



Caution:

Fluid may be in secondary containment – possible tube failure. Depressurise and safely remove from line as soon as possible.

OPTIMASS 8000 / 9000

OPTIMASS	Inductance (mH)		Resistance (Ohm)	
	Driver	Sensor A/B	Driver	Sensor A/B
8000	2.2	0.735	38	12.5
9000	2.6	0.95	67	25

- The above data are provided as a rough guide only.
- Driver = White / Brown
- Sensor A = Orange / Black. Sensor B = Grey / Blue
- RTD = Red / Purple (108Ω at 20°C if PT100, 540Ω at 20°C if PT500). Compensation leg = Purple / Yellow
- Resistance values outside these values could indicate a circuit failure. Meter may be in start-up or have measuring errors.
- All circuit should be isolated from ground (meter case) and each other: >20MΩ. If circuits are shorting to ground, meter may be in start-up.

6.4 Replacing the Front End or Back End Electronics

If a failure occurs in one or the other of the above electronics, these can be easily replaced with the minimum downtime. Please remember to disconnect or switch off the power supply to the meter when performing these tasks. Please observe the waiting time for Hazardous area approved meters.

To make exchanging the components easy, a copy of the Front End calibration coefficients are stored in the Back End as well. This facilitates the changes without the necessity of sensor calibration coefficients.



Note:

The following functions must only be performed by qualified personnel.

6.4.1 Replacing the Front End

- Please unscrew the four small screws holding the Front End in place (screws at the rear).
- Take care when removing to ensure that the connections are not damaged.
- Do not lose the gasket.
- Replace with new Front End electronics, ensuring that the gasket is well positioned and the connections have mated correctly.
- Do not force the connectors.
- Tighten securely.
- It is recommended that some lockite or similar compound is used for the screws.

After power up the measuring system will recognize a hardware change. The display will show Sys. Changed.

Key	Display
	Sys. Changed
→	Select with ↑ key between
↑	New FE (Front End).
→	Select with ↑ key between
↑	Sure No
↑	Sure Yes
Accept with ↵	
↵	Back End data will be used as master.

The Front End software is downloaded from the Back End electronics automatically. The system is now ready to measure. It is recommended that a zero calibration is performed if possible.

6.4.2 Replacing the Back End

Unscrew the front lid and undo the two screws holding the display in place. The two screws holding the converter in the housing can now be seen towards the rear on the steel frame. Take care not to damage any components while attempting to loosen these screws.

The converter will slide out easily after disengaging from the rear terminals in the case of EX/FM converters. If the converter is a general purpose / non EX converter then the plugable terminals in the rear terminal compartment need to be unplugged before the converter can be removed.

To retain the user-configured data, the small EEPROM can be removed and installed on the replacement converter. This will save re-programming the user range and output configuration data.

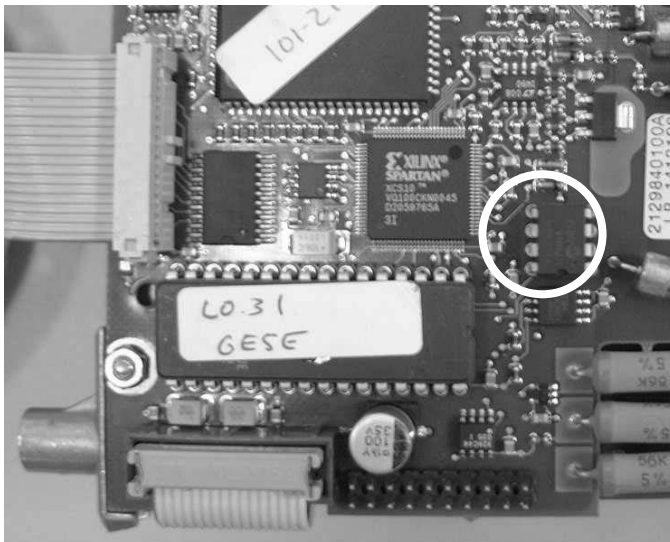

Position of small EEPROM.

The replacement converter can now be installed and fixed in place. Replace the display and close the converter housing. Switch power back on. The display will show Sys. Changed.

Key	Display
	Sys. Changed
→	Select with ↑ key between
↑	New FE (Front End).
↑	New BE (Back End).
→	Select with ↑ key between
↑	Sure No
↑	Sure Yes
Accept with ↵	
↵	Front End data will be used as master.

The meter is now ready to measure. A zero calibration is recommended if possible.



Note:

After Sure Yes has been accepted, the word Uploading will be displayed. Once complete, the meter will display start-up and continue. If the message Failed is displayed, then the configuration stored was not valid and the previous menu will be displayed after pressing the return key. Consult the factory.

6.5 Spares

Description	Part No
Converters	
Complete Display Ex + Non Ex	X2132750100
Front end electronics (cast in SS lid)	X2134330100
Front end gasket	X6870069989
Converter electronics insert (see main price list)	
Converter Output Modules (MFC 050 only)	
1 st current output module non GI	X2107010000
I/O Module, (input/output contact & pulse output)	X2107030000
*RS 485 Module (Modbus)	X2105850000
Dual Frequency output (phase shifted)	X2107620000

* Cannot work with HART module installed. This module must be removed before RS 485 is installed.

Note:



- When exchanging modules on Ex converters you must do a hi-pot test.
This is only recommended for experienced personnel at the Service centres
- Multi I/O modules need to be factory fitted
- Modules for MFC 051 are not field interchangeable

MFC050		
Converter power fuses	24 V DC 1.25 AT	X5090800000
Converter power fuses	100 - 120 V AC 315 m AT	X5058040000
Converter power fuses	200 - 240 V AC 160 m AT	X5073790000

MFC051		
Converter power fuses	100 - 230 V AC 800 m AT	X5080850000
Converter power fuses	24 V AC/DC 1.25 AT	X5116260100

EEPROM for MFC 050/051 (contains converter software) please specify software version required. Large chip	X5104980100
EEPROM for MFC 050/051 (contains customer/user parameter settings) please specify software version required. Small chip	X5104580100

Housings		
Standard housing	X2102900000	
Standard converter housing lid rear	X2117120100	
Standard converter lid front (window)	X2102730000	
Converter housing Ex de	X2102750000	
Converter housing Ex d (flame proof)	X2133350100	
Ex de housing lid rear	X3152210300	
Ex de housing lid front	X2102760100	
Ex d housing lid rear	X3152760500	
Ex d housing lid front	X2102760100	
Makralon window for lid (Food Industry)	X2102730100	
Housing lid "O" ring	X3144230100	
Rubber inserts for Electronics	price/pair	X5850599989
Conduit adaptor 1/2" NPT F (between sensor and converter)	price/pair	X3870959989
Conversion Kit from d housing to IS housing		XV015100535

Terminal Labels for MFC 050 Housing	Pack of 10
Opt 1: 1 x 4-20 mA, 1 x Pulse, 1 x Control input, 1 x Status output-HART	X386054
Opt 2: 1 x 4-20 mA, Modbus	X386056
Opt 3: 1 x 4-20 mA, 1 x Control input, 1 x dual phase frequency output-HART	X586057
Opt 4: 2 x 4-20 mA, 1 x Pulse, 1 x Control input-HART	X386058
Opt 5: 2 x 4-20 mA, 1 x Status output, 1 x Control input-HART	X386055
Opt 6: 3 x 4-20 mA, 1 x Pulse-HART	X886059
Opt 7: 3 x 4-20 mA, 1 x Control input-HART	X386050
Opt 8: 3 x 4-20 mA, 1 x Status output-HART	X386061

Terminal Labels for MFC 051 Housing	(IS outputs)	Pack of 10
Opt 1: 2 x 4-20 mA, outputs		X3159050300
Opt 2: 1 x 4-20 mA, 1 x pulse		X3159050200
Opt 3: 1 x 4-20 mA, 1 x control i/p		X3159050200
Opt 4: 1 x 4-20 mA, 1 x status o/p		X3159050200
Opt 5: 1 x 4-20 mA, 1 x Profibus PA		X3159050400

'O' Ring for Aseptic Unions to DIN 11864-2 –Form A (FDA Compliant)

Size	
DN10	X5874809989
DN15	X5874819989
DN25	X5874829989
DN40	X5874839989
DN50	X5874849989
DN80	X5874859989

Accessories

Housing Lid Wrench	X3310380200
Magnetic Pin for Programming	XVX20705300
Terminal Screwdriver	X5870949989
Grey Non-Ex remote cable	X5871059989
Blue Ex (intrinsically safe) remote cable	X5871069989
Remote cable preparation kit	X1870349989
Conversion kit - Compact to Remote (without cable)	X1870309989
Conversion kit - Remote to Compact	X1870319989
Terminal Separation Kit for IS housing	X1870359989

Service Tools

Simulator SIM 500 (complete with all cables and software) 220V	1861009989
Simulator SIM 500 (complete with all cables and software) 100 / 120V	1861109989
Spare simulator comms. cable (RS 232)	5873329989
Service harness (converter to PC/simulator)	1861019989
USB to 9 pin RS 232 serial converter for service harness or SIM 500	5870269989
Toolbox software only	3861159989

Note :

1. For service : Order service harness and software (for laptops with RS232 ports)
2. For service : Order service harness and software **plus USB converter** (for laptops with USB ports only)

7 External Standards and Codes

7.1 Standards

The OPTIMASS range of mass flow meters comply with some or all of the following standards or codes:

7.1.1 Mechanical



Pressure Equipment Directive PED (acc. to AD2000 Regelewerk)	97/23/EC
Hygienic	ASME Bioprocessing ASME BPEa-2000 Addenda to BPE-1997 3A Dairy Products Standard (28-03) Authorization No. 1246 EHEDG TNO report No. V5247/02
Protection Category IP67 (equiv. Nema 4x and 6) Insulation/Heating jacket on OPTIMASS 8000/9000 – IP54	EN 60529
Custody Transfer	OIML R117 PTB

7.1.2 Electrical

Electromagnetic Compatibility (EMC)	EN 50081-1 1992 EN 50082-2 1994 NAMUR NE21/5-93 89/336/EEC (EMC) 72/23/EEC (Low Voltage Directive)
European Hazardous Area Approval	ATEX – 94/9/EC
US Hazardous Area Approval	FM (Project ID 3015950) / CSA

Further details of approvals and certificates available on request

7.3 PED Certificate

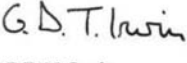
 Confédération Européenne d'Organismes de Contrôle	TÜV UK Ltd. Surrey House, Surrey Street, Croydon CR9 1XZ Tel. 020-8680 7711 Fax. 020-8680 4035 E-mail: london@tuv-uk.com	
CERTIFICATE Of APPROVAL		
No. 97/23/2002/012		
This is to certify that Krohne Limited, Rutherford Drive, Park Farm Industrial Estate, Wellingborough, Northants. NN8 6AE United Kingdom		
has successfully undergone an assessment in accordance with the requirements of Module H of The Pressure Equipment Regulations 1999 (Pressure Equipment Directive 97/23/EC), in conjunction with the AD-Regelwerk 2000, covering the design, manufacture, inspection and testing of OPTIMASS range of Mass Flow Meters within the scope identified on Annexe 1 attached. Krohne Limited is authorised to use the following markings on equipment of Hazard Category II and greater, supplied within the scope of approval:		
		
Issued 30 th October 2002 For and on behalf of TÜV UK Ltd.		
 F. Guyot Managing Director	 G.D.T. Irwin Design Engineer	



TUV UK Ltd.



Sunny House, Sunny Street, Croydon CR9 1XZ
Tel: 020-89967711 Fax: 020-89964035 E-mail: london@tuv-uk.com

Certificate No. 97/23/2002/012
Annexe 1

Product Types Approved under the Pressure Equipment
Regulations 1999:

The OPTIMASS 7000 Series Mass Flow Meter range as
follows:

OPTIMASS 7000 Type	First (Measuring Tube) Pressure Containment		Second (Outer Cylinder) Pressure Containment		Third (Heated Jacket) Pressure Containment	
	Category	Module	Category	Module	Category	Module
06	SEP	n/a	II	H	SEP	n/a
10	SEP	n/a	II	H	SEP	n/a
15	SEP	n/a	II	H	SEP	n/a
25	SEP	n/a	III	H	SEP	n/a
40	II	H	III	H	SEP	n/a
50	II	H	IV	H1	SEP	n/a
80	III	H	IV	H1	SEP	n/a

The OPTIMASS 7100 Series Mass Flowmeter Range as
follows:

OPTIMASS 7100 Type	First (Measuring Tube) Pressure Containment		Second (Outer Cylinder) Pressure Containment		Third (Heated Jacket) Pressure Containment	
	Category	Module	Category	Module	Category	Module
01, 03, 04	SEP	n/a	I (30 bar g)	H	SEP	n/a
01, 03, 04	SEP	n/a	II (63 bar g)	H	SEP	n/a

The certificate of approval identified above is valid until it is
superseded, withdrawn or 10 years have elapsed following the date of issue,
prior to which application may be made for extension.

Approval of Annexe 1

G.D.T. Irwin

G.D.T. Irwin
Design Engineer

Date: 30 October 2002

8 Device Configuration sheet

The following pages can be photocopied for your use when required.

Serial No.	Tag No.		
MENU 3 CONFIGURATION			
3.1.1 L.F. CUTOFF		3.2.6 TEMPERATUR.	
3.1.2 TIME CONST.		3.2.7 DENSITY	
3.1.3 FLOW MODE		3.2.8 CONC. FLOW	
3.1.4 FLOW DIR.		3.2.9 CONC. TOTAL	
3.1.5 PIPE DIAM.		3.2.10 CONC.BY.MASS	
3.1.6 ADD. TOTAL		3.2.11 CONC.BY.VOL.	
3.1.7 ERROR MSG		3.2.12 VELOCITY	
3.1.8 PRESS TIME		3.2.13 LANGUAGE	
3.1.9 PRESS CUTOF		3.3 CONC. MEAS.	See separate sheet in Concentration Manual
3.2.1 CYCL. DISP.		3.4.1 DENS. MODE	
3.2.2 MASS FLOW		3.4.2 FIXED	
3.2.3 MASS TOTAL		3.4.2 REF TEMP	
3.2.4 VOLUME.FLOW		3.4.3 SLOPE	
3.2.5 VOL.TOTAL		3.6.1 TAG ID.	
3.2.6 TEMPERATUR.			
MENU 4 INPUT / OUTPUT CONFIGURATION			
4.1 I.O. FITTED		4.6.1 FUNCTION	
4.2.1 FUNCTION		4.6.2 LOW LIMIT or	
4.2.2 RANGE I		4.6.3 HIGH LIMIT.	
4.2.3 LOW LIMIT		4.6.4 ACTIVLEVEL	
4.2.4 HIGH LIMIT		4.7.1 FUNCTION	
4.3.1 FUNCTION		4.7.2 ACTIVLEVEL	
4.3.2 RANGE I		4.8.1 FUNCTION	
4.3.3 LOW LIMIT		4.8.2 CONDITION	
4.3.4 HIGH LIMIT		4.8.3 LOW LIMIT	
4.4.1 FUNCTION		4.8.4 HIGH LIMIT	
4.4.2 RANGE I		4.9 COMM.MODULE	
4.4.3 LOW LIMIT		4.9.1 PROTOCOL	
4.4.4 HIGH LIMIT		4.9.2 ADDRESS	
4.5.1 FUNCTION		4.9.3 BAUDRATE	
4.5.2 LOW LIMIT or PULSE.WIDTH		4.9.4 SER.FORMAT	
4.5.3 HIGH LIMIT or PULSE VAL.			
4.5.4 MAX FREQ			
MENU 5 FACTORY SETTINGS (Read only)			
5.1.1 CF1		5.2 METER	
5.1.2 CF2		5.2.1 METER TYPE	
5.1.3 CF3		5.2.2 METER SIZE	
5.1.4 CF4		5.2.3 MATERIAL	
5.1.5 CF5		5.2.4 TUBE AMP	
5.1.6 CF6		5.3 TEMP.LIMITS	
5.1.7 CF7		5.3.1 MAX. TEMP.	
5.1.8 CF8		5.3.2 MIN. TEMP.	
5.1.9 CF9		5.4 TEMP. HIST.	
5.1.10 CF10		5.4.1 MAX. TEMP.	
5.1.11 CF11		5.4.2 MIN. TEMP.	
5.1.12 CF12		5.5 SERIAL NO.	
5.1.13 CF13		5.5.1 BACKEND	
5.1.14 CF14		5.5.2 FRONTEND	
5.1.15 CF15		5.5.3 METER	
5.1.16 CF16		5.5.4 SYSTEM	
5.1.17 CF17			
5.1.18 CF18			
5.1.19 CF19			
5.1.20 CF20			
5.1.21 METER CORR.			

Notes

9 Declaration of Cleanliness Certificate

Returning a device for testing or repair to KROHNE

This device has been carefully manufactured and tested. If installed and operated in accordance with these operating instructions, it will rarely present any problems. Should you nevertheless need to return a device for inspection or repair, please pay strict attention to the following points:

Due to statutory regulations on environmental protection and safeguarding the health and safety of our personnel, KROHNE may only handle, test and repair returned devices that have been in contact with products without risk to personnel and environment.

This means that KROHNE can only service this device if it is accompanied by the following certificate confirming that the device is safe to handle.

If the device has been operated with toxic, caustic, flammable or water-endangering products, you are kindly requested:

- to check and ensure, if necessary by rinsing or neutralizing, that all cavities are free from such dangerous substances,
- to enclose a certificate with the device confirming that is safe to handle and stating the product used.

We cannot service this device unless accompanied by such a certificate.

SPECIMEN certificate

Company: Address:
.....

Department: Name:

Tel. No.: Fax No.:

The enclosed device

Type:

KROHNE Order No. or Series No.:

has been operated with the following liquid:

Because this liquid is water-hazardous toxic caustic flammable

we have checked that all cavities in the instrument are free from such substances /

flushed out and neutralized all cavities in the device

We confirm that there is no risk to humans or environment through any residual liquid contained in this device.

Date: Signature:

Company stamp:

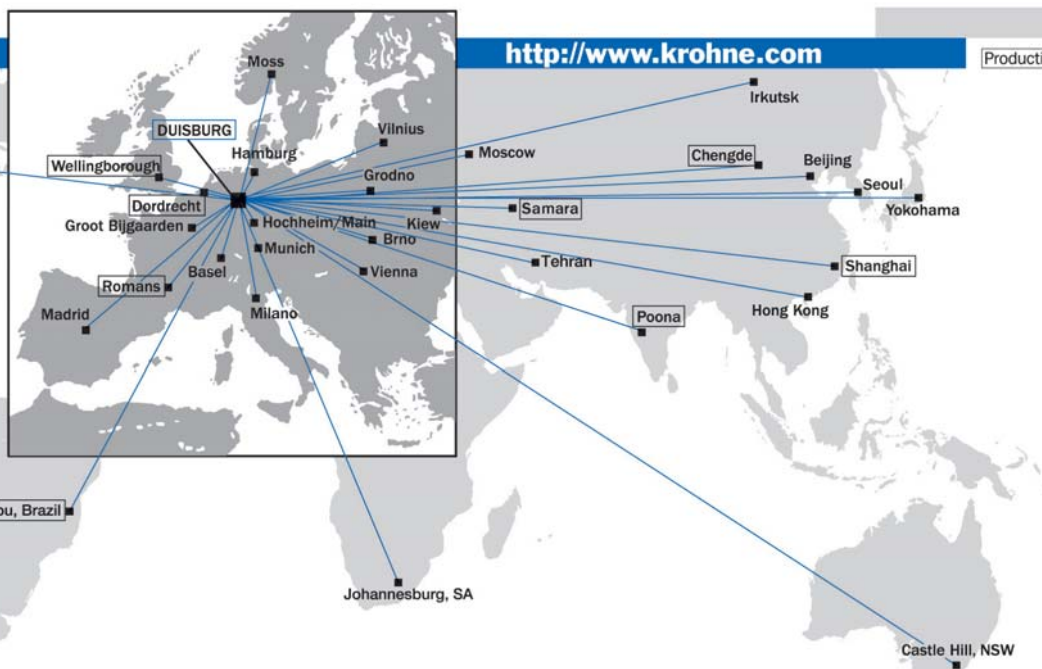

Australia

KROHNE Australia Pty Ltd
Quantum Business Park
10/287 Victoria Rd
Rydalmere NSW 2116
TEL: +61 2 8846 1700
FAX: +61 2 8846 1755
e-mail: krohne@krohne.com.au

Austria

KROHNE Austria Ges.m.b.H.
Modecenterstraße 14
A-1030 Wien
TEL: +43(0)1/203 45 32
FAX: +43(0)1/203 47 78
e-mail: info@krohne.at

Belgium

KROHNE Belgium N.V.
Brusselstraat 320
B-1702 Groot Bijgaarden
TEL: +32(0)2-4 66 00 10
FAX: +32(0)2-4 66 08 00
e-mail: krohne@krohne.be

Brazil

KROHNE Conaut
Controles Automaticos Ltda.
Estrada Das Águas Espraiadas, 230 C.P. 56
06835 - 080 EMBU - SP
TEL: +55(0)11-4785-2700
FAX: +55(0)11-4785-2768
e-mail: conaut@conaut.com.br

China

KROHNE Measurement Instruments
(Shanghai) Co. Ltd., (KMIC)
Room 1501, Tower A
City Centre of Shanghai
100 Zun Yi Road
Shanghai 200051
TEL: +86 21 6237 2770
FAX: +86 21 6237 2771
Cellphone: +86 (0) 139 01954185
e-mail: info@krohne-asia.com

CIS

Kanex KROHNE Engineering AG
Business-Centre Planeta, Office 404
ul. Marxistskaja 3
109147 Moscow/Russia
TEL: +7(0)095-9117165
FAX: +7(0)095-7428873
e-mail: krohne@dol.ru

Czech Republic

KROHNE CZ, spol. s r.o.
Sobesická 156
CZ-63800 Brno
TEL: +420 545 532 111
FAX: +420 545 220 093
e-mail: brno@krohne.cz

France

KROHNE S.A.S.
Les Ors
BP 98
F-26103 ROMANS Cedex
TEL: +33(0)4-75 05 44 00
FAX: +33(0)4-75 05 00 48
e-mail: info@krohne.fr

Germany

KROHNE Messtechnik
GmbH & Co. KG
Ludwig-Krohne-Str.
D-47058 Duisburg
TEL: +49(0)203-301-0
FAX: +49(0)203-301-10 389
e-mail: krohne@krohne.de

India

KROHNE Marshall Ltd.
A-34/35, M.I.D.C.
Industrial Area, H-Block,
Pimpri Poona 411018
TEL: +91(0)202-7442020
FAX: +91(0)202-7442020
e-mail: pcu@vsnl.net

Iran

KROHNE Liaison Office
North Sohrvardi Ave.
26, Sarhad St., Apt. #9
Tehran 15539
TEL: +9821-8874-5973
FAX: +9821-8850-1268
e-mail: krohne@krohneiran.com

Italy

KROHNE Italia Srl.
Via V. Monti 75
I-20145 Milano
TEL: +39(0)2-4 30 06 61
FAX: +39(0)2-43 00 66 66
e-mail: info@krohne.it

Korea

KROHNE Korea
Room 508 Miwon Bldg
43 Yoido-Dong
Youngdeungpo-Ku
Seoul, Korea
TEL: 00-82-2-780-1743
FAX: 00-82-2-780-1749
e-mail: krohnekorea@krohnekorea.com

Netherlands

KROHNE Altometer
Kerkeplaat 12
NL-3313 LC Dordrecht
TEL: +31(0)78-6306300
FAX: +31(0)78-6306390
e-mail: postmaster@krohne-altometer.nl

Netherlands

KROHNE Nederland B.V.
Kerkeplaat 14
NL-3313 LC Dordrecht
TEL: +31(0)78-6306200
FAX: +31(0)78-6306405
Service Direkt: +31(0)78-6306222
e-mail: info@krohne.nl

Norway

KROHNE Norway A.S.
Ekholtveien 114
NO-1526 Moss
P.O. Box 2178, NO-1521 Moss
TEL: +47(0)69-264860
FAX: +47(0)69-267333
e-mail: postmaster@krohne.no
Internet: www.krohne.no

Singapore

Tokyo Keiso - KROHNE Singapore Pte. Ltd.
14, International Business Park,
Jurong East
Chiyoda Building #01-01/02
Singapore 609922
Singapore
TEL: +65-65-67-4548
FAX: +65-65-67-9874

South Africa

KROHNE Pty. Ltd.
163 New Road
Halfway House Ext. 13
Midrand
TEL: +27(0)11-315-2685
FAX: +27(0)11-805-0531
e-mail: midrand@krohne.co.za

Spain

I.I. KROHNE Iberia, S.r.L.
Poligono Industrial Nilo
Calle Brasil, n.º. 5
E-28806 Alcalá de Henares-Madrid
TEL: +34(0)91-8 83 21 52
FAX: +34(0)91-8 83 48 54
e-mail: krohne@krohne.es

Switzerland

KROHNE AG
Uferstr. 90
CH-4019 Basel
TEL: +41(0)61-638 30 30
FAX: +41(0)61-638 30 40
e-mail: info@krohne.ch

United Kingdom

KROHNE Ltd.
Rutherford Drive
Park Farm Industrial Estate
Wellingborough,
Northants NN8 6AE, UK
TEL: +44(0)19 33-408 500
FAX: +44(0)19 33-408 501
e-mail: info@krohne.co.uk

USA

KROHNE Inc.
7 Dearborn Road
Peabody, MA 01960
TEL: +1-978 535-6060
FAX: +1-978 535-1720
e-mail: info@krohne.com

Other Representatives

- | | |
|-------------|--------------|
| Algeria | Kuwait |
| Argentina | Libya |
| Belarus | Lithuania |
| Cameron | Malaysia |
| Canada | Morocco |
| Chile | Mauritius |
| Colombia | Mexico |
| Croatia | New Zealand |
| Denmark | Peru |
| Ecuador | Poland |
| Egypt | Portugal |
| Finland | Romania |
| Gabon | Saudi Arabia |
| Ghana | Senegal |
| Greece | Slovakia |
| Hong Kong | Slovenia |
| Hungary | Sweden |
| Indonesia | Taiwan |
| Ivory Coast | Thailand |
| Iran | Turkey |
| Ireland | Tunisia |
| Israel | Venezuela |
| Japan | Yugoslavia |
| Jordan | |

Other Countries

KROHNE Messtechnik
GmbH & Co. KG
Ludwig-Krohne-Str.
D-47058 Duisburg
TEL: +49(0)203-301-0
FAX: +49(0)203-301-389
e-mail: export@krohne.de