

Installation and operating instructions

BATCHFLUX 5015 K

Compact electromagnetic
flowmeters



Please note!

Do not open the housing of the BATCHFLUX IFM 5015 K.

Danger of contamination with substances likely to destroy the moisture barrier of the electronic equipment (e.g. if CIP or SIP cleaned from the outside).

Therefore, please contact your KROHNE Service engineer before you open the housing.

Contents

System description	4
Standards and approvals	4
Product liability and warranty	4
Functional description BATCHFLUX IFM 5015 K	5
Part A System installation and start-up	6 - 16
1 Installation in the pipeline	6 - 11
1.1 Important information	6
1.2 Suggestions for installation	7
1.3 Installation requirements	8-9
1.3.1 Position of flange	9
1.3.2 Example: centering and sealing the primary head	9
1.3.3 Grounding	9
1.4 Installation of the primary head	10
1.4.1 Device description	10
1.4.2 Installation of the IFM 5015 K	10
1.5 Size of connections	11-12
1.5.1 Fastening with tie bolts	11
1.5.2 Fastening with tie bolts (option)	12
2 Electrical connection	13 - 14
2.1 Important information	13
2.2 Attachment plugs	13
2.3 Power supply and outputs	14
3 Start-up	15 - 16
3.1 Checking for availability	15
3.2 Factory settings	16
Part B IFC 015 signal converter	17 - 34
4 Operator control of signal converter with the HHT 010	17 - 27
4.1 Operator control concept	17
4.2 Operating and check elements	18
4.3 Function of keys	18 - 19
4.4 Table of settable functions	20 - 24
4.5 Error messages in measuring mode	25
4.6 Resetting totalizers and deleting error messages, RESET / QUIT menu	26
5 Description of functions	28 - 35
5.1 Full-scale range $Q_{100\%}$	28
5.2 Time constant	28
5.3 Low-flow cutoff	28
5.4 Display with HHT 010	29
5.5 Internal electronic totalizer	30
5.6 Current output I	30
5.7 Pulse output P	30 - 31
5.8 Status output S (option)	32
5.9 Language	32
5.10 Entry code	33
5.11 Primary head	33
5.12 User-definable unit	34
5.13 F/R mode, forward / reverse flow measurement	35
5.14 Characteristic of outputs	35

Part C Special applications, functional checks, and service	36 - 42
6 Special applications	36
6.1 RS 232 adapter and KROHNE software (option)	36
6.2 Operation via HHT 010 hand-held terminal (option)	36
7 Functional checks	37 - 39
7.1 Zero check with signal converter IFC 015	37
7.2 Test of measuring range Q, Fct. 2.1	38
7.3 Hardware information and error status, Fct. 2.2	39
8 Service	40 - 41
8.1 Important advice for removing the flowmeter from the pipeline – PLEASE NOTE	40
8.2 Removal from the pipe system	40
8.3 Removal of the electronics unit	41
8.4 Restart	41
9 Illustrations of printed circuit boards	42
Part D Technical Data, block diagram and measuring principle	43 - 49
10 Technical data	43 - 47
10.1 Flow during filling and fill volume	43
10.2 Flowmeters	43
10.3 Signal converter	44
10.4 Error limits at reference conditions	45
10.5 Dimensions and weights	46 - 47
10.6 Instrument nameplates	47
11 Block diagram	48
12 Measuring principle	49
Part E Annex	50 - 52
E1 Index	50 - 51
E2 Form to accompany returned device	52

Please note!

Do not open the housing of the BATCHFLUX IFM 5015 K.

Danger of contamination with substances likely to destroy the moisture barrier of the electronic equipment (e.g. if CIP or SIP cleaned from the outside).

Therefore, please contact your KROHNE Service engineer before you open the housing.

System description

The BATCHFLUX IFM 5015 K compact electromagnetic flowmeter is a precision instrument designed for the linear flow measurement of liquid products.

The products need to be electrically conductive:

- > 5 $\mu\text{S}/\text{cm}$ (except for water)
- > 20 $\mu\text{S}/\text{cm}$ (for water)

The full-scale range $Q_{100\%}$ can be set as a function of the meter size:

DN 2.5 – 40 and $1\frac{1}{10}$ " – $1\frac{1}{2}$ " $Q_{100\%} = 0.0015 - 15 \text{ l/s}$

This is equivalent to a flow velocity of 0.3 - 12 m/s.

Standards and approvals

- BATCHFLUX IFM 5015 K with the IFC 015 signal converter meets the **EU-EMC Directives** and bears the **CE and 3A symbol**.
- The 3A approval accepts only adapters shown in Sect. 1.5.
- All factories and production sequences are ISO 9001 certified.



Product liability and warranty

The compact BATCHFLUX IFM 5015 K electromagnetic flowmeter is designed exclusively for measuring the volumetric flowrate of electrically conductive, liquid process products.

The compact flowmeter is not suitable for use in hazardous areas. Other flowmeter series are available for such applications.

Responsibility as to suitability and intended use of this compact electromagnetic flowmeter rests solely with the operator.

Improper installation and operation of the flowmeters (systems) may lead to loss of warranty.

In addition, the "General conditions of sale" forming the basis of the purchase contract are applicable.

If BATCHFLUX IFM 5015 K flowmeters need to be returned to KROHNE, please note the information given on the last-but-one page of these instructions. KROHNE regret that they cannot repair or check your flowmeter(s) unless these are accompanied by the completed form sheet.

Functional description
BATCHFLUX IFM 5015 K

The volume to be filled into the container is measured "in line" by means of the electromagnetic flowmetering system. The batch controller closes the filling valve once the preset filling volume has been reached. It is always the preset target volume that is filled into the container.

The signal converter converts the measured flowrate signal into volume pulses that are intelligible to the batch controller. For a filling volume of 1000 ml, for example, this could be 10 pulses per ml; in other words, the batch controller switches the valve off after 1000 pulses have been received.

The influence of valve closing times and other dynamic factors can be corrected by the adaptive corrector of the batch controller.

The use of state-of-the-art microprocessor electronics and the high-speed analog/digital converter also enables changes in the flowrate to be sensed precisely. This technology ensures high reproducibility and long-term stability.

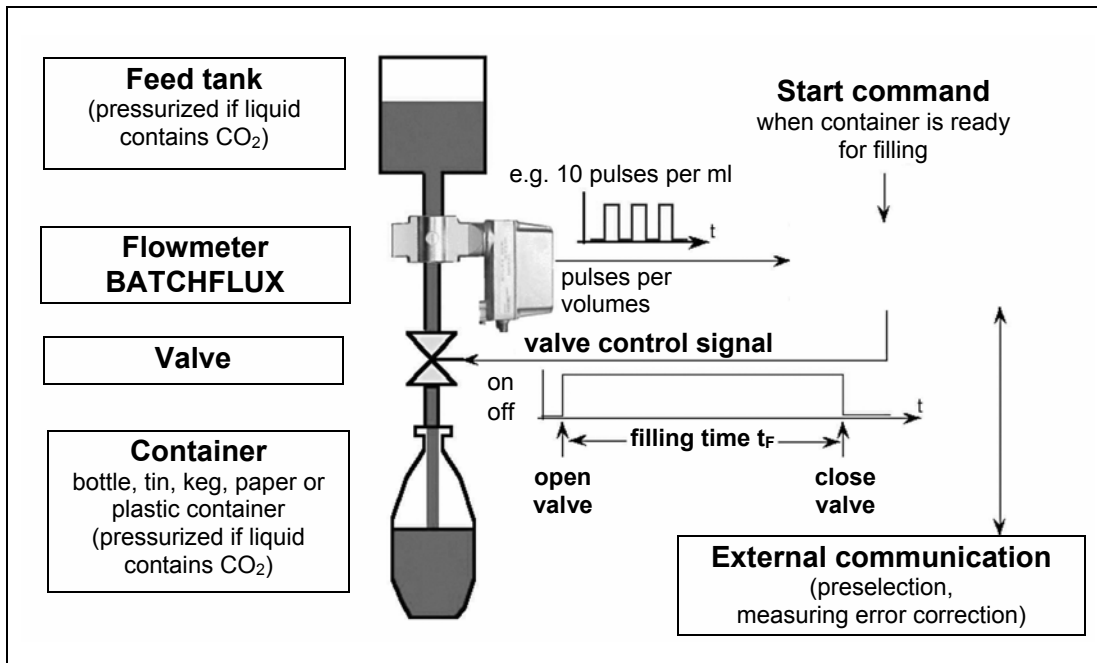

Part A System installation and start-up

1 Installation in the pipeline

1.1 Important information

The following recommendations should be observed to ensure proper functioning of the flowmeter – PLEASE NOTE.

- **Measuring tube must be completed filled at all times.**
 - **Direction of flow:** the red arrow on the housing of the primary head must point in the direction of flow. If for structural reasons the flowmeter can only be installed counter to the direction of flow, the direction of flow measurement can be reprogrammed.
 - **Stud bolts and nuts:** to fit, make sure there is sufficient room next to the pipe flanges.
 - **Vibration:** support the pipeline on both sides of the flowmeter. Vibration level to IEC 068-2-34: below 2,2g in the 20 - 2000 Hz frequency range.
 - **Radiant heat:** avoid e.g. from hot product tanks, insulate if necessary.
 - **Avoid strong electromagnetic fields** in vicinity of flowmeter.
 - **Straight Inlet run $\geq 5 \times \text{DN}$ and straight outlet run $\geq 2 \times \text{DN}$,** measured from the electrode axis (DN = meter size).
 - **Vortex or corkscrew flow:** increase length of inlet and outlet runs or install flow straighteners.
 - **Mixing different process liquids:** install flowmeter upstream of mixing point or at an adequate distance downstream, minimum of $30 \times \text{DN}$ (DN = meter size), otherwise display may be unsteady.
 - **Plastic pipes and internally coated metal pipes:** grounding rings required, see "Grounding", Section 1.3.3.
 - **Heat-insulated pipelines:** do not insulate flowmeter.
 - **Zero setting:** not required. For checking purpose, see Section. 7.1, it should be possible to set "zero" flow velocity in the completely filled measuring tube. Shutoff valves should therefore be provided either downstream or upstream and downstream of the flowmeter.
 - **Ambient temperature**
-25°C to +60°C
 - **Process temperature**
max. 140 °C
 - **Transport and storage temperature**
-25°C to +60°C
- Limits imposed by the material** used for the measuring tube for process temperature, thermal shock limit, pressure and vacuum, see Section 10.2 "Limits".
- Please note!**
The ceramic measuring tube must not contact metal parts (flange, pipeline). This can destroy the flowmeter!

1.2 Suggestions for installation



To avoid measuring errors due to air inclusion and vacuum, please observe the following:

Highest point of pipe run

(Air bubbles collect in measuring tube - faulty measurements!)

Preferred locations

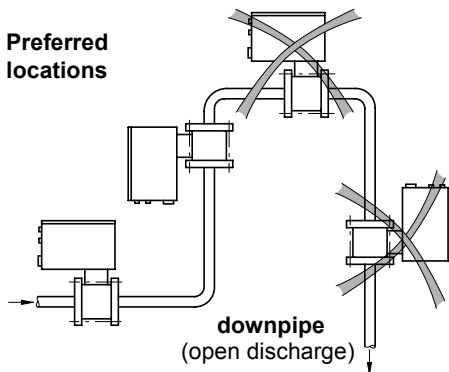

Avoid draining or partial filling of the measuring tube. Faulty measurements.

Horizontal pipe run

Install in slightly descending pipe section to prevent air from collecting, so avoiding faulty measurements and that meter can drain.

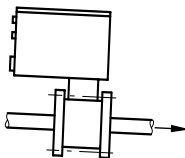

Control and shutoff valves: always install behind the flowmeter

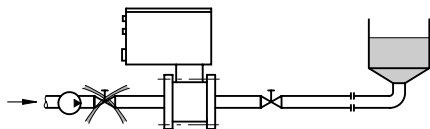

Pumps

Do not install flowmeter on pump suction side

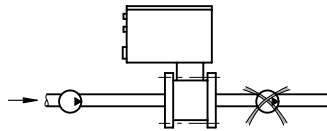

Open feed or discharge

Install meter in low section of pipe

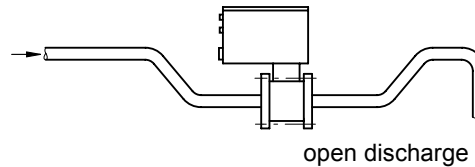

Selecting the installation location

Location and position as required, but electrode axis (X - - - - X) must be approximately horizontal in a horizontal pipe run.

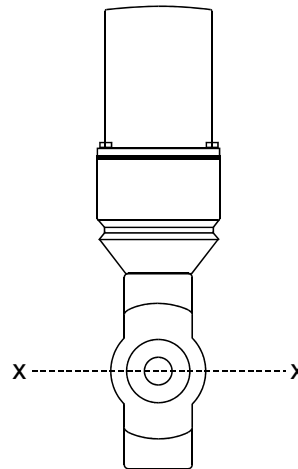

Direction of flow The red arrow on the primary head housing must point in the flow direction.



On high-temperature pipes and where process temperatures exceed 100 °C, provide facilities to compensate for longitudinal expansion on heat-up of the pipeline. Use flexible pipe elements (e.g. elbows).

1.3 Installation requirements

Items supplied with flowmeter

- BATCHFLUX IFM 5015 K compact flowmeter in the version as ordered
- Installation and operating instructions, as agreed
- Certificate of system calibration data (as agreed)

Excluding fitting accessories. Stud bolts, gaskets, etc., to be provided by customer.

All operating data and function values are factory set according to your order specifications.

Requirements

Use in the food industry

The IFM 5015 K is specifically suitable for use in the food and beverage industry or similar sterile processes.

The IFM 5015 K is steam-resistant and can be pigged.

The measuring tube can be SIP or CIP cleaned when in installed condition. During the cleaning the meter(s) must be switched off to maintain the reliability of the unit(s).

- Operating pressure, type, and space between pipe flanges: see Table.
- Tighten stud bolts uniformly down to the metal stop in diagonally opposed sequence. See Table for type and number of stud bolts.
- Install meter vertically or in a slope due to its conical in/outlet.
On DN 15 ($1/2''$) and DN 32 ($1\ 1/4''$), a BATCHFLUX with straight ceramic tube is available.

DIN 2501 and JIS	ANSI B 16.5	Space between pipe flanges	Bolts	Max torque		
				Nm	kpm	ft × lbf
DN 2.5	$1/10''$	51.8 mm (2.04")	4 x M12	10	1.0	7.2
DN 4	$1/8''$	51.8 mm (2.04")	4 x M12	10	1.0	7.2
DN 6	$1/4''$	51.8 mm (2.04")	4 x M12	10	1.0	7.2
DN 10	$3/8''$	51.8 mm (2.04")	4 x M12	10	1.0	7.2
DN 15	$1/2''$	51.8 mm (2.04")	4 x M12	10	1.0	7.2
DN 25	1"	58.0 mm (2.28")	4 x M12	10	1.0	7.2
DN 32	$1\ 1/4''$	83.0 mm (3.27")	4 x M16	43	4.3	31.0
DN 40	$1\ 1/2''$	83.0 mm (3.27")	4 x M16	43	4.3	31.0

1.3.1 Position of flanges

Install flowmeter in line with the pipe axis. Pipe flange faces must be parallel to each other, max. allowable deviation:

$$L_{\max} - L_{\min} \leq 0.5 \text{ mm} \leq 0.02''$$

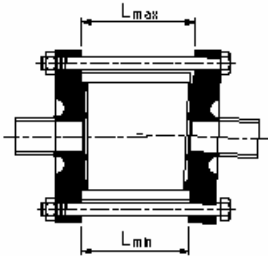

1.3.2 Example: centering and sealing the primary head

The primary head is centered between the pipe flanges with the aid of the precise geometric fitting (guide collar on primary head).

Detail drawings see Sect. 1.5.

1.3.3 Grounding

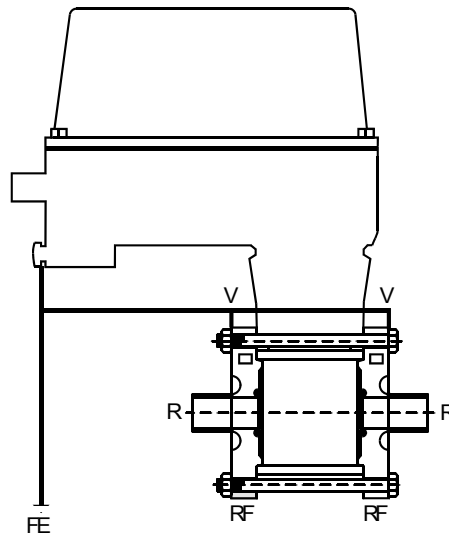

FE	Functional ground, wire > 4 mm ² Cu.
R	Pipeline
RF	Pipe flanges
V	Interconnecting wires, bolted to the housing



- All flowmeters **must** be properly grounded.
- The grounding wire should not transmit any interference voltages. Therefore do not ground any other electrical device simultaneously with this conductor.

Grounding is carried out via the **functional ground** that is connected to the U-clamp terminal (9). See also Section 2 "Electrical connection".

When connected to functional extra-low voltages,

24 V DC, protective separation (PELV) must be ensured (VDE 0100/VDE 0106 or IEC 364/IEC 536).

1.4 Installation of the primary head

1.4.1 Device description

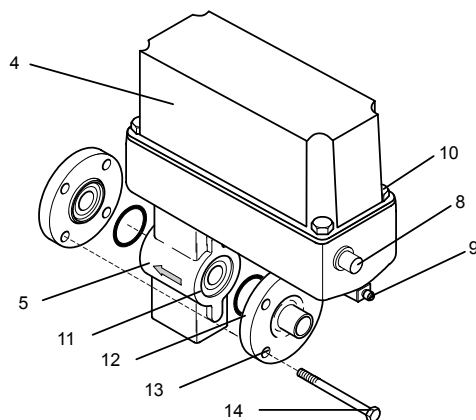

- **BATCHFLUX IFM 5015 K**

- 4 Cover, signal converter
- 5 Primary head
- 8 Connector for power and pulse output (optionally: and status output)
- 9 U-clamp terminal for functional ground
- 10 Fastening screws for cover
- 11 Locating collar, primary head

- **Accessories from system manufacturer**

- 12 O-ring gasket
- 13 Special pipe flange
- 14 Stud bolt with lock washer, plain washer and nut



To facilitate servicing of the primary head, please note the following points:

- It must be possible to shut off the flow through the pipeline upstream of the primary head (provide shutoff valve),
- Drain the pipe system before removing the primary head (provide drain valve),
- Support the pipeline on both sides of the flowmeter when located in a long, freely suspended section to facilitate removal of the primary head.

1.4.2 Installation of the IFM 5015 K

- Position gaskets (12) in the pipe flanges.
- Type and location of gaskets as specified by the manufacturer of the filling machine (see Sect. 1.3.2 "Centering of the primary head").
- Insert primary head (5) between the pipe flanges (13) in line with the pipe axis.
- For spacing and location of the pipe flanges, see Sect. 1.3 "Position of flanges".
- Press pipe flanges against flowmeter.



Centering ring of pipe flanges must snap into place in the guide collar (11) of the primary head.

- Insert stud bolts (14) with washers into the holes in the pipe flanges. Fit nuts to stud bolts with lock washer.
- Tighten stud bolts and nuts down to the metal stop symmetrically. Check all bolts after starting up the pipe system, and retighten when any leaks show.
- Connect ground conductor to U-clamp terminal (9).
- Connect power supply and passive pulse output to connector plugs (7, 8) on signal converter housing (4).

See Section 2.2 and 2.3 for details of electrical connection.

1.5 Size of connections

1.5.1 Fastening with tie bolts

All dimensions in mm (inches)

Flange-material: AISI 300 series
 O-ring material: 3A standard 18-03

Meter size		Centering device, pipe connection				O-Ring 75 Shore	Dimensions	
DN	inches	d _i	D1	D2	h		k	d
2.5	1/10	6 (0.24)	25.5 (1.00)	30 (1.18) <small>-0.05/-0.15 -0.002/-0.006</small>	1.5 (0.06) <small>-0.05/-0.15 -0.002/-0.006</small>	on request on request	60 (2.36)	8.5 (0.33)
4	1/8	7 (0.28)	25.5 (1.00)	30 (1.18) <small>-0.05/-0.15 -0.002/-0.006</small>	1.5 (0.06) <small>-0.05/-0.15 -0.002/-0.006</small>	on request on request	60 (2.36)	8.5 (0.33)
6	1/4	9 (0.35)	25.5 (1.00)	30 (1.18) <small>-0.05/-0.15 -0.002/-0.006</small>	1.5 (0.06) <small>-0.05/-0.15 -0.002/-0.006</small>	on request on request	60 (2.36)	8.5 (0.33)
10	3/8	12 (0.47)	25.5 (1.00)	30 (1.18) <small>-0.05/-0.15 -0.002/-0.006</small>	1.5 (0.06) <small>-0.05/-0.15 -0.002/-0.006</small>	on request on request	60 (2.36)	8.5 (0.33)
15	1/2	14 (0.55)	25.5 (1.00)	30 (1.18) <small>-0.05/-0.15 -0.002/-0.006</small>	1.5 (0.06) <small>-0.05/-0.15 -0.002/-0.006</small>	Ø 16×5 (Ø 0.47×0.20)	60 (2.36)	8.5 (0.33)
25	1	26 (1.02)	37.5 (1.48)	71.3 (2.81) <small>-0.1 -0.004</small>	2 (0.08) <small>+0.1 +0.04</small>	Ø 28×5 (Ø 1.10×0.20)	80 (3.15)	8.5 (0.33)
32	1 1/4	on request						
40	1 1/2	on request						

DN 2.5 - 15 / 1/10" - 1/2"

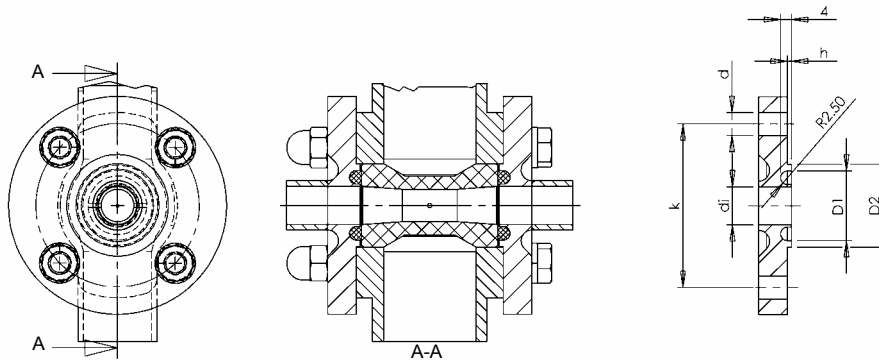

DN 25 / 1"

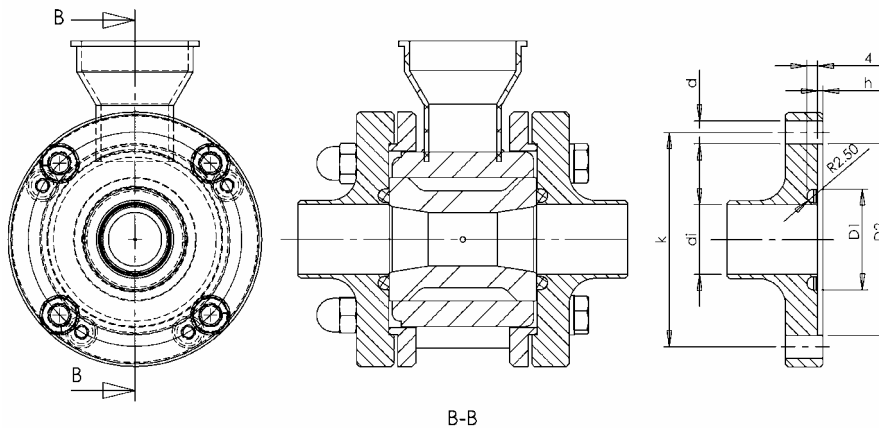

DN 32-40 /
1 1/4" - 1 1/2"

Dimensions
on request

1.5.2 Fastening with bolts (option)

All dimensions in mm (inches)

* Flange-material : AISI 300 series
O-ring material : 3A standard 18-03

Meter size		Centering device, pipe connection				O-ring gaskets	Screw thread (option)			
							2× M4		4× M6	
DN	inches	d _i	D1	D2	h	75 Shore	k	d	k	d
2.5	1/10	6	25.5	30	1.5	on request	60	8.5	56	6.4
		(0.24)	(1.00)	(1.18)	(0.06)	on request	(2.36)	(0.33)	(2.20)	(0.25)
4	1/8	7	25.5	30	1.5	on request	60	8.5	56	6.4
		(0.28)	(1.00)	(1.18)	(0.06)	on request	(2.36)	(0.33)	(2.20)	(0.25)
6	1/4	9	25.5	30	1.5	on request	60	8.5	56	6.4
		(0.35)	(1.00)	(1.18)	(0.06)	on request	(2.36)	(0.33)	(2.20)	(0.25)
10	3/8	12	25.5	30	1.5	on request	60	8.5	56	6.4
		(0.47)	(1.00)	(1.18)	(0.06)	on request	(2.36)	(0.33)	(2.20)	(0.25)
15	1/2	14	25.5	30	1.5	Ø 16×5 *	60	8.5	56	6.4
		(0.55)	(1.00)	(1.18)	(0.06)	(Ø 0.47×0.20)*	(2.36)	(0.33)	(2.20)	(0.25)

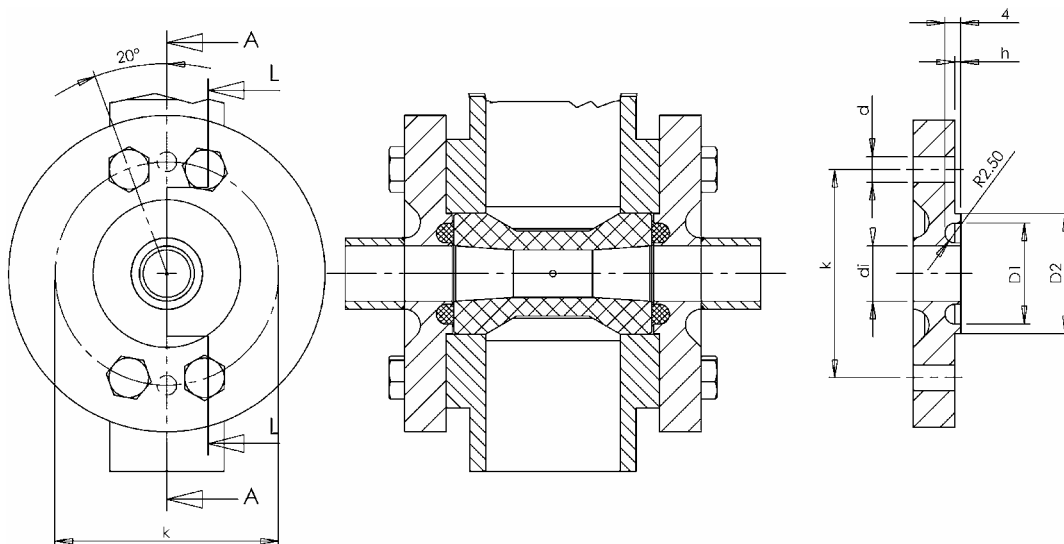

2 Electrical connection

2.1 Important information

Be sure to take note of the following information in order to ensure proper functioning of the signal converter.

Please note:

- 1) Overvoltage class:
In conformity with VDE 0120, equivalent to IEC 664, the compact flowmeters are designed for overvoltage category III in the supply circuits and overvoltage category II in the output circuits.
- 2) Safety isolation:
The compact flowmeters must be provided with an isolating facility.

Electrical connection and repairs may only be carried out by qualified personnel.

- Protect the flowmeter from direct **radiant heat** (e.g. hot-product tanks), insulate if necessary.
- Do not expose flowmeter to intense **vibration**. If necessary, support the pipeline to the right and left of the flowmeter. Level of vibration in accordance with IEC 068-2-34: below 2.2g in the 20 - 2000 Hz frequency range.
- Note information given on the **instrument nameplate**, voltage.
- The **FE functional ground** for the supply power should for measurement reasons be connected to the separate U-clamp terminal on the signal converter housing.
- **When connected to a functional extra-low voltage of 24 V DC**, protective separation (PELV) must be ensured (VDE 0100 / VDE 0106 or IEC 364 / IEC 536 or equivalent national regulations)..

2.2 Attachment plugs

Manufacturer	Series and type	Description
Binder	Series 715	Moulded plug, straight or angle-entry form
	Series 763	Integrally extruded plug with cable in various lengths
Hirschmann	E-Series	
	ELKA 4012 and ELWIK A 4012	Moulded plug, straight or angle-entry form
	ELKA KV 4412 and ELWIK A KV 4412	Integrally extruded plug with cable in various lengths
Lumberg	RK-Series	
	RKC and RKCW	Moulded plug, straight or angle-entry form
	RKT and RKWG	Integrally extruded plug with cable in various lengths
Amphenol	Series C 164 P	Moulded plug, straight or angle-entry form
	Series C 164 P compact	Integrally extruded plug with cable in various lengths
Coninvers	Series BC	Moulded plug, straight form, especially suitable for high-interference environments (keyword: EMC)

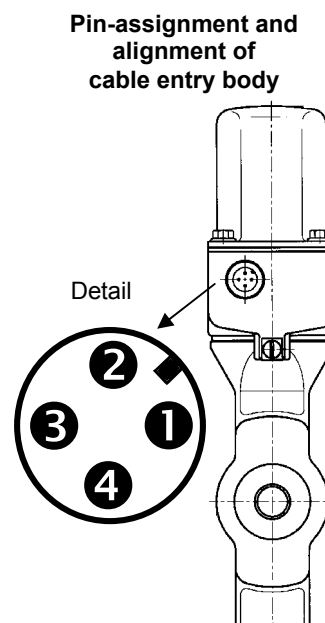

2.3 Power supply and outputs

Standard 4-pin connector M12x1 for 24 V DC power supply and passive pulse output

Pin	Standard
1	+ 24 V
2	pulse output
3	pulse output \perp
4	ground

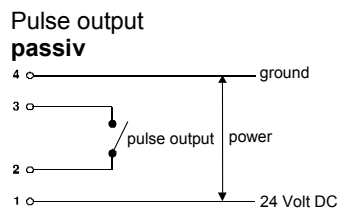

Pin assignment

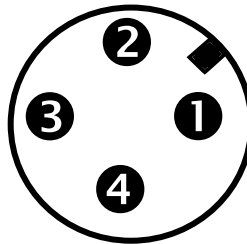

$$U_{\text{ext.}} \leq 30 \text{ V DC} / \leq 24 \text{ V AC}$$

$$I_{\text{max}} \leq 20 \text{ mA}$$

The pulse output is galvanically isolated from the 24 V power supply.

Pulse output

- All operating data and functions are settable (see Sect. 6).
- All data and functions are factory-set to your specifications. See also Sect. 3.2 "factory settings".
- Connection of electronic totalizers.
- Digital pulse division. Interpulse period non-uniform, therefore if frequency meters or cycle counters connected, allow for minimum counting interval: counter gate time [s] $\geq \frac{1000}{P_{100\%}[\text{Hz}]}$
- Pulse rate for Q = 100% max. 10 kHz, fixed or optionally in pulses per m³, litres, US gallons or user-defined unit
- Pulse width
 - ≤ 10 Hz: 50, 100, 200 or 500 ms
 - > 10 Hz: - automatic, pulse width = $\frac{1}{2 \times f_{100\%}}$
 - symmetrical 1:1

3 Start-up

Before powering the system, check that it has been correctly installed according to Sections 1 and 2.

The compact flowmeter is delivered ready for operational use. All operating data have been factory set in accordance with your specifications.

Power the unit, and the flowmeter will immediately start process flow measurement.

3.1 Check for availability

Please note!

Do not open the housing of the BATCHFLUX IFM 5015 K.

Danger of contamination with substances likely to destroy the moisture barrier of the electronic equipment (e.g. if CIP or SIP cleaned from the outside).

Therefore, please contact your KROHNE Service engineer before you open the housing.

- The measurement status is signalled by the light-emitting diodes (LED) below the cover of the converter housing (see amplifier board on right).

LED 1	LED 2	Function
flashing	off	in order
flashing	flashing	overdriving
on	flashing	Fatal Error (defective operating parameter)
off	on	defective hardware
off	off	no supply voltage or hardware is defective

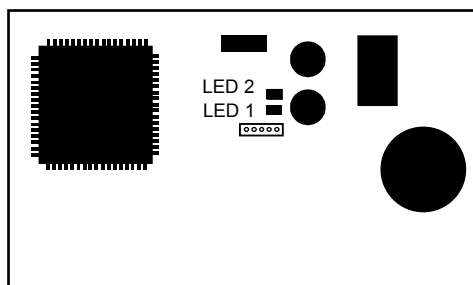

- Refer to Section 6 for operator control.

Furthermore, external facilities (hand-held communicator HHT 010, PC, etc.) can be connected on the pc board of the control electronics via the IMoCom interface. This will enable precise checking of the correct mode of operation of the Batchflux IFM 5015 K.

All operating data can be set and stored by means of a personal computer via the IMoCom interface. The digital IMoCom interface allows the complete filling procedure to be graphically represented on the PC, thus providing visualization of system and valve properties.

3.2 Factory settings

All operating data are factory-set according to your order specifications.

To facilitate easy and rapid initial start-up, pulse output is - unless specified otherwise - set to process flow measurement in "2 flow directions" so that the current flowrate is displayed and the volumetric flow counted independent of the direction of flow.

The factory setting for the current and pulse outputs may occasionally cause measuring errors, particularly in the case of volume flow counting. For example, if pumps are switched off and a "backflow" occurs that is not within the range of the low-flow cutoff (SMU), or if separate displays and counts are required for both flow directions. To avoid faulty measurements, therefore, it may be necessary to change the factory setting of some or all of the following functions:

- low-flow cutoff SMU, Fct. 1.3
- pulse output P, Fct. 1.6

Table of standard factory settings

Function	Setting
1.1 Full-scale range $Q_{100\%}$	see instrument nameplate
1.2 Time constant	3 s, for S (option)
1.3 Low-flow cutoff SMU (do not change setting!)	ON: 4 % OFF: 5 %
1.4 Display	
1.5 Current output I (NO HARDWARE !) (function must be set to "OFF"!)	OFF
1.6 Pulse output P Function Pulse value Pulse width	1 direction 1000 pulses/s automatically
1.7 Status output (NO HARDWARE !) (function must be set to "OFF"!)	OFF
3.1 Language for display only	English (or other)
3.2 Flowmeter Size Flow direction (see arrow on primary head)	see instrument nameplate + direction
3.4 Entry code	no
3.5 User-definable unit	Liter/h

Part B IFC 015 signal converter

4 Operator control of signal converter with HHT 010 (option)

4.1 Operator control concept

Please note!

Do not open the housing of the BATCHFLUX IFM 5015 K.
 Danger of contamination with substances likely to destroy the moisture barrier of the electronic equipment (e.g. if CIP or SIP cleaned from the outside).
Therefore, please contact your KROHNE Service engineer before you open the housing.

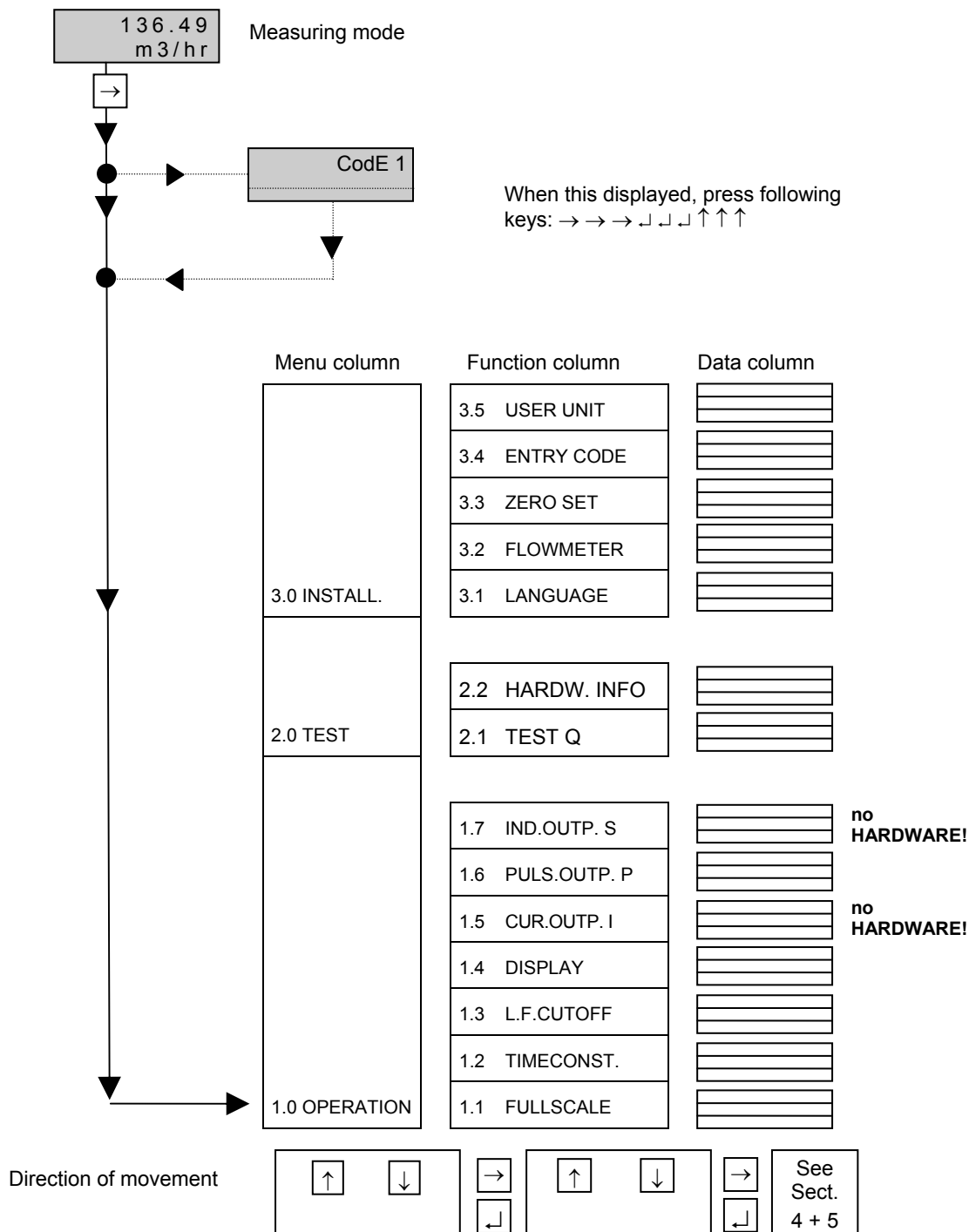

4.2 Operating and check elements

The following operating elements are featured on the hand-held communicator HHT 010:

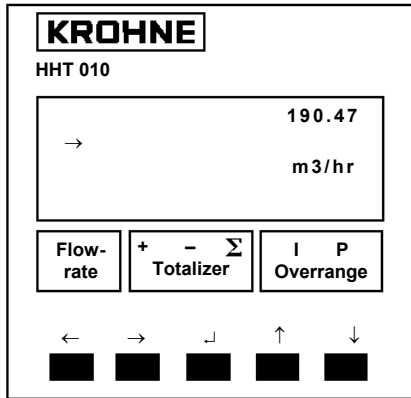

Display, 1st line

Display, 2nd line

Display, 3rd line: arrows to identify display

Flowrate current flowrate

Totalizer + totalizer
- totalizer
Σ sum totalizer (+ and -)

Overrange I overranging, current output
P overranging, pulse output P

Keys for operator control of signal converter

Compass field, signals actuation of a key

4.3 Function of the keys

The **cursor**, flashing part of display, has a **grey** background in the following descriptions.

To start operator control

Measuring mode



Operator control mode



PLEASE NOTE: when “YES“ is set under **Fct. 3.4 ENTRY CODE**, “**CodE 1** -----“ appears in the display after pressing key → . Now enter the 9-keystroke Entry Code 1: → → → ↓ ↓ ↓ ↑ ↑ ↑ (each keystroke acknowledged by “*“).

To terminate operator control

Press key ↓ repeatedly until one of the following menus **Fct. 1.0 OPERATION**, **Fct. 2.0 TEST** or **Fct. 3.0 INSTALL.** is displayed.

Press key ↓

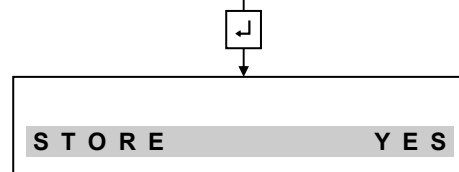
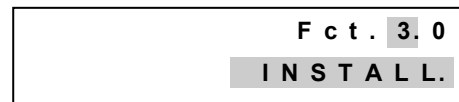

Store new parameters:

Confirm by pressing key ↓ . Measuring mode continued with the new parameters.

Do not store new parameters:

Press key ↑ to display “STORE.NO“. Measuring mode continued with the “old“ parameters after pressing key ↓ .

To change numbers

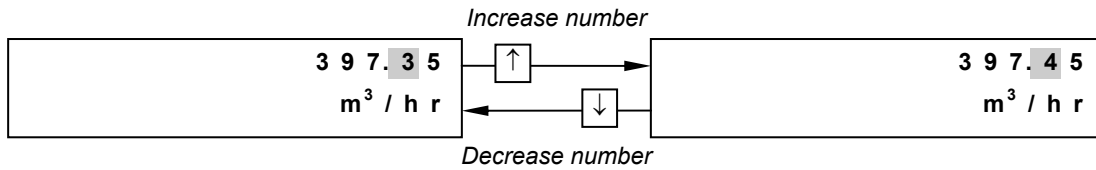

To shift cursor (flashing_position)

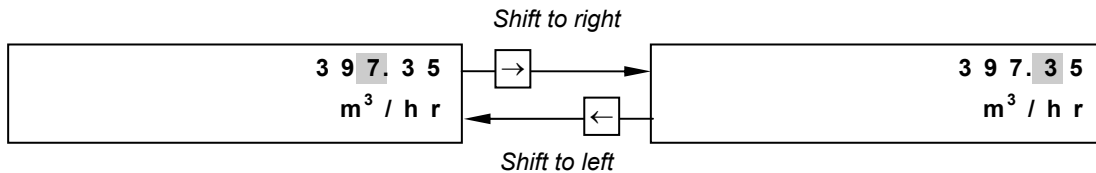

To alter texts (units)

For units, the numerical value is converted automatically

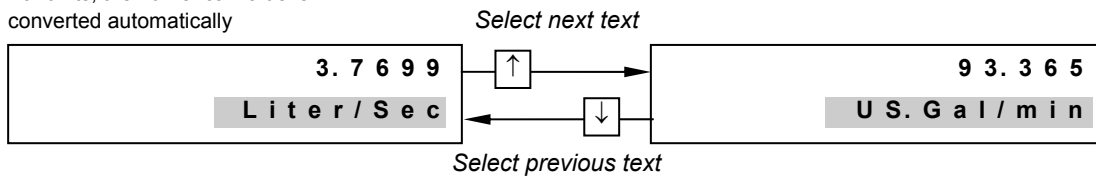

To transfer from text (unit) **to number setting**

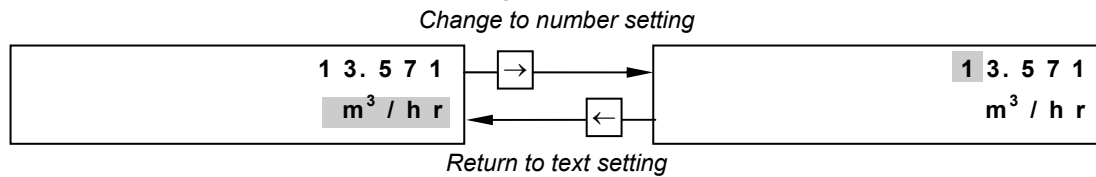

To transfer to subfunction

Subfunctions do not have a "Fct. No." and are identified by a "→".

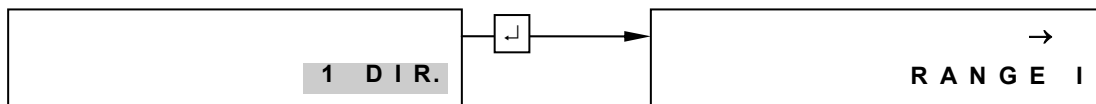

To revert to function display

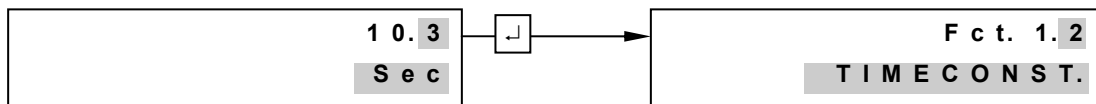

4.4 Table of settable functions

Abbreviations used

DN	Nominal size, meter size
F_{max}	Highest frequency of the pulse output
F_{min}	Lowest frequency of the pulse output
F_M	Conversion factor volume for any unit, see Fct. 3.5 "FACT.VOL."
F_T	Conversion factor time for any unit, see Fct. 3.5 "FACT.TIME"
GKL	Primary constant
I	Current output (no HARDWARE)
P	Pulse output
P_{max}	= F _{max} / Q _{100%}
P_{min}	= F _{min} / Q _{100%}
Q	actual flow rate
Q_{100%}	100% flow = full-scale range
Q_{max}	= $\frac{\pi}{4} DN^2 \times v_{max} / \text{max. full-scale range (Q}_{100\%})$ at v _{max} = 12 m/s
Q_{min}	= $\frac{\pi}{4} DN^2 \times v_{min} / \text{min. full-scale range (Q}_{100\%})$ at v _{min} = 0,3 m/s
S	Status output (no HARDWARE)
SMU	Low-flow cutoff for I and P
v	Flow velocity
v_{max}	Max. flow velocity (12 m/s) at Q _{100%}
v_{min}	Min. flow velocity (0,3 m/s) at Q _{100%}
F/R	Forward/reverse flow in F/R mode

Fct.	Text	Description and settings
1.0	OPERATION	Operations menu
1.1	FULL.SCALE	<p>Full-scale range for flowrate Q_{100%}</p> <p><u>Select unit</u></p> <ul style="list-style-type: none"> • m³/hr • Liter/Sec • US.Gal/min <p>• user unit, factory set is "Liter/hr" (see Fct. 3.5)</p> <p><i>Press key → to transfer to number setting!</i></p> <p><u>Setting ranges</u></p> <p>The ranges are dependent on the meter size (DN) and the flow velocity (v):</p> $Q_{min} = \frac{\pi}{4} DN^2 \times v_{min}$ $Q_{max} = \frac{\pi}{4} DN^2 \times v_{max}$ <ul style="list-style-type: none"> • BATCHFLUX IFM 5015 K : 0.0053 – 54 m³/hr 0.0015 – 15 Liter/Sec 0.02377 – 237.7619 US.Gal/min <p><i>Press key ↵ to return to Fct. 1.1 FULL SCALE.</i></p>
	→ VALUE P	<p>Change pulse value (see Fct. 1.6 "VALUE P")</p> <p>Appears only when "PULSE/VOL." set under Fct. 1.6 "SELECT. P" and the output frequency (F) has been over- or undershot:</p> $P_{min} = F_{min} / Q_{100\%}$ $P_{max} = F_{max} / Q_{100\%}$
1.2	TIME CONST.	<p>Time constant</p> <p><u>Selection:</u></p> <ul style="list-style-type: none"> • ALL (applies to display and all outputs) • ONLY I+S (display, current and status outputs only, no current output) <p><i>Press key ↵ to transfer to number setting!</i></p> <p><u>Range:</u></p> <ul style="list-style-type: none"> • 0.2 – 99.9 Sec <p><i>Press key ↵ to return to Fct.1.2 TIMECONST.</i></p>

Fct.	Text	Description and settings
1.3	L.F. CUTOFF	<p>Low-flow cutoff (SMU)</p> <ul style="list-style-type: none"> • OFF (fixed values: ON = 0.1% / OFF = 0.2%, at 100 Hz - 1000 Hz, see Fct.1.6, 1% and 2%) • PERCENT (variable values) ON 1 – 19% OFF 2 – 20% <p><i>Press key → to transfer to number setting!</i></p> <p>Note: cutoff "off" value must be greater than cutoff "on" value!</p> <p><i>Press key ↵ to return to Fct. 1.3 L.F.CUTOFF</i></p>
1.4	DISPLAY	Display functions
	→ DISP. FLOW.	<p>Select flow display (only HHT 010)</p> <ul style="list-style-type: none"> • NO DISP. • user unit, factory set is "Liter/hr" (see Fct. 3.5) • m³/hr • PERCENT • Liter/Sec • US.Gal/min • BARGRAPH (value and bargraph display in %) <p><i>Press key ↵ to transfer to subfunction "DISP.TOTAL".</i></p>
	→ DISP. TOTAL.	<p>Select totalizer display</p> <ul style="list-style-type: none"> • NO DISP. (totalizer switched on but not displayed) • OFF (totalizer switched off) • m³ • Liter • US.Gal • user unit, factory set is "Liter" (see Fct. 3.5) <p><i>Press key → to transfer to format setting!</i></p> <p>Format setting</p> <ul style="list-style-type: none"> • Auto (exponent notation) • # . ##### • ##### . ### • ## . ##### • ##### . ## • ### . ##### • ##### . # • #### . ##### • ##### <p><i>Press key ↵ to transfer to subfunction "DISP.MSG.".</i></p>
	→ DISP. MSG.	<p>Additional messages required in measuring mode?</p> <ul style="list-style-type: none"> • NO • YES <p>(cyclic change with meas. value displays)</p> <p><i>Press key ↵ to return to Fct.1.4 DISPLAY.</i></p>

Fct.	Text	Description and settings
1.5	CURRENT I	<p>Current output I</p> <p>No hardware available</p>
1.6	PULS.OUTP. P	Pulse output P
	→ FUNCTION P	<p>Select function for pulse output P</p> <ul style="list-style-type: none"> • OFF (switched off) • 1 DIR. (1 direction of flow) • 2 DIR. (forward/reverse flow, F/R flow measurement) <p><i>Press key ↵ to transfer to subfunction "SELECT P".</i></p>
	→ SELECT. P	<p>Select pulse type</p> <ul style="list-style-type: none"> • 100-1000 Hz • PULSE/VOL (pulses per unit volume, flow) • 100-1000 Hz • PULSE/TIME (pulses per unit time for 100% flow) <p><i>Press key ↵ to transfer to subfunction "PULSWIDTH".</i></p> <p><i>When 100 Hz - 1000 Hz selected, return to Fct.1.6 PULS.OUTP. P, (pulse width 50%, cyclic).</i></p>
	→ PULSWIDTH	<p>Select pulse width</p> <ul style="list-style-type: none"> • 50 mSec • 100 mSec • 200 mSec • 500 mSec <p><i>Press key ↵ to transfer to subfunction "VALUE P".</i></p>

Fct.	Text	Description and settings
1.6	→ VALUE P	<p>Set pulse value per unit volume (appears only when "PULSE/VOL." set under "SELECT.P" above)</p> <ul style="list-style-type: none"> • xxxx PulS/m3 • xxxx PulS/Liter • xxxx PulS/US.Gal • xxxx PulS/ user unit, factory set is "Liter" (see Fct. 3.5) <p>Setting range "xxxx" depends on the pulse width and the full-scale range:</p> $P_{min} = F_{min} / Q_{100\%}$ $P_{max} = F_{max} / Q_{100\%}$ <p>Press key ↵ to return to Fct.1.6 "PULS.OUTP.P".</p>
	→ VALUE P	<p>Set pulse value per unit time (appears only when "PULSE/TIME" set under "SELECT. P" above)</p> <ul style="list-style-type: none"> • xxxxx PulSe/Sec (=Hz) • xxxx PulSe/min • xxxx PulSe/hr • xxxx PulSe/user unit, factory set is "hr" (see Fct. 3.5) <p>Setting range "xxxx" depends on pulse width, see above.</p> <p>Press key ↵ to return to Fct. 1.6 "PULS.OUTP. P".</p>
1.7	STATUS. S	<p>Status output S</p> <p>No hardware available</p>

Fct.	Text	Description and settings
2.0	TEST	Test menu
2.2	TEST Q	<p>Test of range Q</p> <p><u>Precautionary query</u></p> <ul style="list-style-type: none"> • SURE NO <p>Press key ↵ to return to Fct. 2.1 "TEST Q".</p> <ul style="list-style-type: none"> • SURE YES <p>Press key ↵ and select value with keys ↑ and ↓: -110 / -100 / -50 / -10 / 0 / +10 / +50 / +100 / +110 PCT. of set measuring range Q_{100%} in each case.</p> <p>Displayed value present at outputs I and P.</p> <p>Press key ↵ to return to Fct. 2.1 "TEST Q".</p>
	HARDW. INFO	<p>Hardware information and error status</p> <p>Please note down all 6 codes before consulting factory.</p>
	→ MODUL ADC	<p>X . X X X X X . X X Y Y Y Y Y Y Y Y Y Y</p> <p>Press key ↵ to transfer to "MODUL I/O".</p>
	→ MODUL I/O	<p>X . X X X X X . X X Y Y Y Y Y Y Y Y Y Y</p> <p>Press key ↵ to transfer to "MODUL DISP".</p>
→ MODUL DISP.	<p>X . X X X X X . X X Y Y Y Y Y Y Y Y Y Y</p> <p>Press key ↵ to return to Fct. 2.2 "HARDW. INFO".</p>	

Fct.	Text	Description and settings
3.0	INSTALL.	Installation menu
3.1	LANGUAGE	Select language for display texts <ul style="list-style-type: none"> • GB / USA (English) • F (French) • D (German) • others on request <i>Press key ↵ to return to Fct. 3.1 "LANGUAGE".</i>
3.2	FLOW-METER	Set data for primary head
	→ DIAMETER	Select size from table of meter sizes <ul style="list-style-type: none"> • BATCHFLUX IFM 5015 K DN 2.5 - 40 mm equivalent to $1/10$ - $1\frac{1}{2}$ inches <i>Select with key ↑ or ↓.</i> <i>Press key ↵ to transfer to subfunction "FULL SCALE".</i>
	→ FULL SCALE	Full scale range for flow $Q_{100\%}$ To set, refer to Fct. 1.1 "FULL SCALE" above. <i>Press key ↵ to transfer to subfunction "GKL VALUE".</i>
	→ VALUE P	Change pulse value (see Fct. 1.6 "VALUE P") Appears only when "PULSE/VOL." has been set under Fct. 1.6 "SELECT. P" and the output frequency (F) has been over- or undershot: $P_{min} = F_{min} / Q_{100\%}$ $P_{max} = F_{max} / Q_{100\%}$
	→ GKL VALUE	Set primary constant GKL see instrument nameplate for primary head Range: • 1.0000 - 9.9999 <i>Press key ↵ to transfer to subfunction "FLOW DIR.".</i>

Fct.	Text	Description and settings
	→ FIELD FREQ.	Magnetic field frequency Do not change setting ! Values $1/2$, $1/6$ and $1/18$ of 50 Hz or 60 Hz, see nameplate. <i>Press key ↵ to transfer to subfunction "FLOW DIR.".</i>
	→ FLOW DIR.	Define direction of flow (in F/R mode: forward flow) Set according to direction of arrow on primary head. • + DIR. • - DIR. <i>Select with key ↑ or ↓.</i> <i>Press key ↵ to return to Fct. 3.2 "FLOWMETER".</i>

Fct.	Text	Description and settings
3.3	ZERO SET	<p>Zero calibration</p> <p>Note: Carry out only when flow is "0" and measuring tube is completely filled!</p> <p><u>Precautionary query</u></p> <ul style="list-style-type: none"> • CALIB. NO Press key \downarrow, return to Fct. 3.3 "ZERO". • CALIB. YES Press key \downarrow to start calibration. Duration approx. 10 seconds. Current flowrate displayed in the selected unit (see Fct. 1.4 "DISP.FLOW") A "WARNING" sign appears when flowrate "> 0". Confirm with key \downarrow. • STORE NO (do not store new zero value) • STORE YES (store (store new zero value) <p>Press key \downarrow to return to Fct. 3.3 "ZERO SET".</p>
3.4	ENTRY CODE	<p>Entry code required to enter setting mode?</p> <ul style="list-style-type: none"> • NO (= entry with \rightarrow only) • YES (= entry with \rightarrow and Code 1: $\rightarrow \rightarrow \rightarrow \downarrow \downarrow \downarrow \uparrow \uparrow \uparrow$) <p>Press key \downarrow to return to Fct. 3.4 "ENTRY CODE".</p>
3.5	USER UNIT	<p>Set any required unit for flowrate and counting</p>
	\rightarrow TEXT VOL.	<p>Set text for required flowrate unit (max. 5 characters) Factory-set: "Liter" (= Liters). <u>Characters assignable to each place:</u> • A-Z, a-z, 0-9, or „ – “ (= blank character) Press key \downarrow to transfer to subfunction "FACT. VOL.".</p>
	\rightarrow FACT. VOL.	<p>Set conversion factor (F_M) for volume Factory set: "1.00000 E+3" for "Liter" (exponent notation, here: 10^3). <u>Factor F_M</u> = volume per $1m^3$. <u>Setting range</u> • 1.00000 E-9 to 9.99999 E+9 (= 10^{-9} to 10^{+9}) Press key \downarrow to transfer to subfunction "TEXT TIME".</p>

Fct.	Text	Description and settings
	\rightarrow TEXT TIME	<p>Set text for required flow unit (max. 3 characters) Factory-set: "hr" (= hour). <u>Characters assignable to each place:</u> • A-Z, a-z, 0-9, or " – " (= blank character) Press key \downarrow to transfer to subfunction "FACT.TIME".</p>
	\rightarrow FACT. TIME	<p>Set conversion factor (F_T) for time Factory set: "3.60000 E+3" for "hour" (exponent notation, here: 3.6×10^3). <u>Factor F_T</u>: set in seconds. <u>Setting range</u> • 1.00000 E-9 to 9.99999 E+9 (= 10^{-9} bis 10^{+9}) Press key \downarrow to return to Fct. 3.5 "USER UNIT".</p>

4.5 Error messages in measuring mode

The following list gives all errors that are likely to occur during process flow measurement. Errors are shown in the display when "YES" is set in Fct. 1.4 DISPLAY, subfunction "DISP.MSG."

Error message	Description of error	Error clearance
LINE INT.	Power failure <u>Note:</u> no counting during power failure	Delete error message in RESET/QUIT menu. If necessary, reset totalizer.
PULS.OUTP. P	Pulse output overranged. <u>Note:</u> totalizer deviation possible.	Check instrument parameters and correct, if necessary. After cause has been eliminated, error message is deleted automatically.
ADC	Analog/digital converter overranged.	After cause has been eliminated, error message is deleted automatically.
FATAL. ERROR	Fatal Error; all outputs set to "Min. values".	Please consult factory.
TOTALIZER	Totalizer has been reset.	Delete error message in RESET/QUIT menu.

4.6 Resetting totalizer and deleting error messages, RESET / QUIT menu

Cancel error messages in RESET / QUIT menu

Key	Display	Description
	----- / ---	Measuring mode
↵	CodE 2 --	Key in Entry Code 2 for RESET/QUIT menu: → ↑
↑→	ERROR QUIT.	Menu for error acknowledgement
→	QUIT. NO	Do not delete error messages. Press ↵ twice = return to measuring mode.
↑	QUIT. YES	Delete error messages
↵	ERROR QUIT.	Error messages deleted
↵	----- / ---	Return to measuring mode

Reset totalizer(s) in RESET / QUIT menu

Key	Display	Description
	----- / ---	Measuring mode
↵	CodE 2 --	Key in Entry Code 2 for RESET/QUIT menu: → ↑
↑→	ERROR QUIT.	Menu for error acknowledgement
↑	TOTAL. RESET	Menu for resetting totalizer
→	RESET NO	Do not reset totalizer. Press ↵ twice = return to measuring mode.
↑	RESET. YES	Reset totalizer
↵	RESET QUIT.	Totalizer reset
↵	----- / ---	Return to measuring mode



Notes

5 Description of functions

Please note!

Do not open the housing of the BATCHFLUX IFM 5015 K.

Danger of contamination with substances likely to destroy the moisture barrier of the electronic equipment (e.g. if CIP or SIP cleaned from the outside).

Therefore, please contact your KROHNE Service engineer before you open the housing.

5.1 Full-scale range $Q_{100\%}$

Fct. 1.1 FULL SCALE

Press key \rightarrow .

Selection of unit for

full-scale range $Q_{100\%}$

- **m³/hr** (cubic metres per hour)
- **Liter/Sec** (litres per second)
- **US.Gal/min** (US gallons per minute)
- user-defined unit; factory-set is here "Liter/hr" (litres per hour), see Sect. 5.12

Select with keys \uparrow and \downarrow .

Use key \rightarrow to transfer to numerical setting, 1st digit (cursor) flashes.

Set full-scale range $Q_{100\%}$

The setting range is dependent on the meter size (DN) and the flow velocity (v):

$$Q_{\min} = \frac{\pi}{4} DN^2 \times v_{\min} \quad Q_{\max} = \frac{\pi}{4} DN^2 \times v_{\max}$$

(refer to flow table in Sect. 10.1)

Change flashing digit (cursor) with keys \uparrow and \downarrow . Use keys \rightarrow and \leftarrow to shift cursor 1 place to right or left.

Press key \downarrow to return to Fct. 1.1 FULL SCALE.

Note: if "VALUE P" is displayed after pressing key \downarrow . PULSE/VOL is set under Fct. 1.6 PULS.OUTPUT. P, subfunction "SELECT P". Due to the changed full-scale range $Q_{100\%}$, the output frequency (F) of the pulse output is over- or undershot:

$$P_{\min} = F_{\min} / Q_{100\%} \quad P_{\max} = F_{\max} / Q_{100\%}$$

Change pulse value accordingly, see Sect. 5.7 pulse output P, Fct. 1.6.

5.2 Time constant

Fct. 1.2 TIMECONST.

Press key \rightarrow .

Selection

- **ALL** (applies to HHT 010-display and all outputs)
- **ONLY I + S** (only valid for HHT 010 display, current and status outputs, no current output, no hardware)

Select with keys \uparrow and \downarrow .

Transfer to number setting with key \downarrow , 1st digit. (cursor) flashes.

Set numerical value

- **0.2 - 99.9 Sec** (seconds)

Change flashing digit (cursor) with keys \uparrow and \downarrow . Use keys \rightarrow and \leftarrow to shift cursor 1 place to right or left.

Press key \downarrow to return to Fct. 1.2 TIMECONST.

5.3 Low-flow cutoff

Fct. 1.3 L.F.CUTOFF (do not change setting!)

Press key \downarrow .

Selection

- **OFF**
(fixed trip points: ON = 0.1 % / OFF = 0.2 %, at 100 - 1000 Hz, see Fct.1.6, 1% and 2%)
- **PERCENT**
(variable trip points: ON = 1-19% /OFF = 2-20%)

Select with keys \uparrow and \downarrow . Transfer to number setting with key \rightarrow (only when "PERCENT" selected), 1st digit (cursor) flashes.

Setting the numerical value when "PERCENT" selected

- 01 to 19 (cutoff "on" value, left of hyphen)
- 02 to 20 (cutoff "off" value, right of hyphen)

Change flashing digit (cursor) with keys \uparrow and \downarrow . Shift cursor 1 place to right or left with keys \rightarrow and \leftarrow . Press key \downarrow to return to Fct. 1.3 L.F.CUTOFF.

Note: the cutoff "off" value must be greater than the cutoff "on" value.

5.4 Display with HHT 010

Fct. 1.4 DISPLAY

Press key \downarrow .

→ DISP.FLOW = Select unit for display of flowrate, press key →

- **NO DISP.** (not displayed)
- **m³/hr** (cubic metres per hour)
- **Liter/Sec** (litres per second)
- **US.Gal/min** (US gallons per minute)
- **User-defined unit;** factory-set is „Liter/hr“ (litres per hour), see Sect. 5.12
- **PERCENT** (percentage display)
- **BARGRAPH** (numerical value and bar graph display in %)

Select with keys \uparrow and \downarrow .

Press key \downarrow to transfer to subfunction „DISP.COUNT“

→ DISP.COUNT = Select unit for totalizer display, press key →

- **NO DISP.** (not displayed)
- **OFF** (internal totalizer switched off)
- **m³** (cubic metres)
- **Liter** (litres)
- **US.Gal** (US gallons)
- **user-defined unit;** factory-set is „Liter“, see Sect. 5.12

Select with keys \uparrow and \downarrow .

Transfer to totalizer format setting with key →.

Setting of totalizer format

- **Auto** (exponent notation)
- **# . #####** • **##### . ###**
- **## . #####** • **##### . ##**
- **### . #####** • **##### . #**
- **#### . #####** • **#####**

Select with keys \uparrow and \downarrow .

Transfer to subfunction „DISP.MSG.“ with key \downarrow .

→ DISP.MSG. = Additional messages required in measuring mode, press key →

- **NO** (no other messages)
- **YES** (display other messages, e.g. errors, in sequence with the measured values)

Select with keys \uparrow and \downarrow .

Press key \downarrow to return to Fct. 1.4 DISPLAY.

Note: „BUSY“ is displayed in the measuring mode when all displays are set to „NO DISP.“ and „NO“. Sequencing of displays is automatic. However, in the measuring mode, manual sequencing can be carried out with keys \uparrow and \downarrow . Return to automatic sequencing after approx. 3 minutes.

Please refer to Sect. 3.2

„Factory settings“.

5.5 Internal electronic totalizer

The internal electronic totalizer counts in m³, regardless of the unit set under Fct. 1.4, subfunction „DISP.FLOW“.

The counting range is dependent upon the meter size and has been selected such that the totalizer will count for a minimum of 1 year without overflow:

Meter size		Counting range
DN mm	inches	in m ³
2,5 - 40	¹ / ₁₀ - 1 ¹ / ₂	0 - 999 999.99999999

Only part of the totalizer count is shown in the display because it is not possible to output a 14-digit number. Unit and format of the display are freely selectable, see Fct. 1.4, subfunction „DISP.COUNT“ and Sect. 5.4. This determines which part of the count is to be displayed. Display overflow and totalizer overflow are independent of one another.

Example

Internal count	0000123 . 7654321	m ³
Format,		
display unit	XXXX . XXXX	Liter
Internal count		
in unit	0123765 . 4321000	Liter
Displayed	3765 . 4321	Liter

5.6 Current output I

No HARDWARE!
Function must be set to "OFF".

5.7 Pulse output P

Fct. 1.6 PULS.OUTP. P

Press key → .

→ **FUNCTION P = Select function for the pulse output,** *press key →*

- **OFF** (switched off, no function)
- **1 DIR.** (1 flow direction)
- **2 DIR.** (2 flow directions, F/R mode, forward/reverse)

Select with keys ↑ and ↓.

Transfer to *subfunction* "SELECT P" with key ↵. **Exception:** when "OFF" selected, return to Fct. 1.6 PULS.OUTP. P.

→ **SELECT P = Select pulse type,** *press key →*

- **100-1000 Hz**
- **PULSE/VOL.** (pulses per unit volume, flow)
- **PULSE/TIME** (pulses per unit time for 100 % flow)

Select with keys ↑ and ↓.

Transfer to *subfunction* "PULSEWIDTH" with key ↵.

Note: when 100-1000 Hz selected, return to Fct. 1.6 PULS.OUTP. P.

→ **PULSEWIDTH = Select pulse width,** *press key →*

- **50 mSec** \underline{F}_{\max} = 10 Hz
 - **100 mSec** \underline{F}_{\max} = 5 Hz
 - **200 mSec** \underline{F}_{\max} = 2.5 Hz
 - **500 mSec** \underline{F}_{\max} = 1 Hz
- for all \underline{F}_{\min} = 0.0056 Hz
(= 20 pulses / hr)

Select with keys ↑ and ↓.

Transfer to *subfunction* "VALUE P" with key ↵ or return to Fct. 1.6 PULS.OUTP. P, depending on selected pulse type in *subfunction* "SELECT P".

→ **VALUE P = Set pulse value per unit volume,**

(appears only when "PULSE/VOL." has been set under "SELECT P"),_press key →

- **XXXX PulS/m³**
- **XXXX PulS/Liter**
- **XXXX PulS/US.Gal**
- **XXXX PulS/** user-defined unit,
factory-set is "Liter", see Sect. 5.12.

Select with keys ↑ and ↓.

Transfer to number setting with key →, 1st digit (cursor) flashes.

Set numerical value

- **XXXX** (Setting range depends on pulse width and full-scale range:
 $P_{\min} = F_{\min} / Q_{100\%}$
 $P_{\max} = F_{\max} / Q_{100\%}$)

Change flashing digit (cursor) with keys ↑ and ↓,
 Shift cursor 1 place to right or left with keys → and ←.
 Press key ↵ to return to Fct. 1.6 PULS.OUTP. P.

or

→ **VALUE P = Set pulse value per unit time,**

(appears only when "PULSE/TIME" has been set under "SELECT P"),_press key →

- **XXXXX PulSe/Sec** (max. 10 kHz)
- **XXXX PulSe/min**
- **XXXX PulSe/hr**
- **XXXX PulSe/** user-defined unit,
factory-set is "hr", see Sect. 5.12.

Select with keys ↑ and ↓.

Transfer to number setting with key →, 1st digit (cursor) flashes.

Set numerical value

- **XXXX** (Setting range depends on pulse width)

Change flashing digit (cursor) with keys ↑ and ↓,
 Shift cursor 1 place to right or left with keys → and ←.
 Press key ↵ to return to Fct. 1.6 PULS.OUTP. P.

Please refer to Sect. 3.2

"Factory settings"

Refer to Sect. 2.3 for connection diagrams,
 and to Sect. 5.14 for characteristics.

5.8 Status output S (option)

No HARDWARE!
Function must be set to “OFF”.

5.9 Language

Fct. 3.1 LANGUAGE

Press key → .

Select language for texts in display

- **D** (German)
- **GB** (English)
- **F** (French)
- others available on request

*Select with keys ↑ and ↓.
Press key ↵ to return to Fct. 3.1 LANGUAGE.*

5.10 Entry Code

Fct. 3.4 ENTRY CODE

Press key → .

Selection

- **NO** (no code, press key → to enter setting mode)
- **YES** (enter setting mode with key → and Code 1: → → → ↓ ↓ ↓ ↑ ↑ ↑)

Select with keys ↑ and ↓.

Press key ↓ to return to Fct. 3.4 ENTRY CODE.

5.11 Primary head

Fct. 3.2 FLOWMETER

Press key → .

→ **DIAMETER = Set the meter size**
(see instrument nameplate) press key → .

Select size from table of meter sizes:

- **BATCHFLUX IFM 5015 K : DN 2,5 - 40 mm** equivalent to 1/10 - 1 1/2 inches

Select with keys ↑ and ↓.

Transfer to subfunction "FULL SCALE" with key ↓.

→ **FULL SCALE = Set the full-scale range,**
press key → .

Set as described in Sect. 5.1.

Transfer to subfunction "GKL VALUE" with key ↓.

Note: if "VALUE P" is displayed after pressing key ↓ .
PULSE/VOL. has been set under Fct. 1.6
PULS.OUTP. P, subfunction "SELECT P".
Because the full-scale range $Q_{100\%}$ has been changed, the output frequency (F) of the pulse output is over- or undershot:

$$P_{\min} = F_{\min} / Q_{100\%}$$

$$P_{\max} = F_{\max} / Q_{100\%}$$

Change pulse value accordingly, see Sect. 5.7
Pulse output P, Fct. 1.6.

→ **GKL VALUE = Set the primary constant GK,** press key → .

- **1.0000 - 9.9999** (note information on instrument nameplate, do not change setting !)

Change flashing digit (cursor) with keys ↑ and ↓ . Shift cursor 1 place to right or left with keys → and ← .

Transfer to subfunction "FLOW DIR." with key ↓.

→ **FIELD FREQ. = Magnetic field frequency,** press key → .

- **1/2** (1/2, 1/6 or 1/18 or 50 Hz or 60 Hz,
- **1/6** see instrument nameplate,
- **1/18** do **not** change setting !)

The magnetic field frequency is determined by the program.

Select with keys ↑ and ↓.

Transfer to subfunction "FLOW DIR." with key ↓.

→ **FLOW DIR. = Set the direction of flow,**
press key → .

- **+ DIR.**
- **- DIR.** (for identification of flow direction see "+" arrow on primary head, in F/R mode this identifies the "positive" flow direction)

Select with keys ↑ and ↓.

Press key ↓ to return to Fct. 3.2 FLOWMETER.

Zero check: see Fct. 3.3 and Sect. 7.1.

Please refer to Sect. 3.2
"Factory settings"

5.12 User-definable unit

Fct. 3.5 USER UNIT

Press key → .

→ **TEXT VOL. = Set the text for user-defined flow unit,** *press key* →

- **Liter** (max. 5 characters, factory-set is "Liter") Characters assignable to each place: **A-Z, a-z, 0-9**, or "-" (= blank)

Change flashing place (cursor) with keys ↑ and ↓. Shift cursor 1 place to right or left with keys → and ←. Transfer to subfunction "FACT.VOL" with key ↵.

→ **FACT. VOL. = Set factor F_M for volume,** *press key* →

- **1.00000 E+3** (factory-set is "1000" / Factor F_M = volume per 1 m³) Setting range: 1.00000 E-9 to 9.99999 E+9 (= 10⁻⁹ to 10⁺⁹)

Change flashing place (cursor) with keys ↑ and ↓. Shift cursor 1 place to right or left with keys → and ←. Transfer to subfunction "TEXT TIME" with key ↵.

→ **TEXT TIME = Set text für required time,** *press key* →

- **hr** (max. 3 places, factory-set is "hr = hour")
Characters assignable to each place: **A-Z, a-z, 0-9**, or "-" (= blank)

Change flashing place (cursor) with keys ↑ and ↓. Shift cursor 1 place to right or left with keys → and ←. Transfer to subfunction "FACT.TIME" with key ↵.

→ **FACT. TIME = Set Factor F_T for time,** *press key* →

- **3.60000 E+3** (factory-set is "3600" / set Factor F_T in seconds)
Setting range: 1.00000 E-9 to 9.99999 E+9 (= 10⁻⁹ to 10⁺⁹)

Change flashing place (cursor) with keys ↑ and ↓. Shift cursor 1 place to right or left with keys → and ←. Press key ↵ to return to Fct. 3.5 USER UNIT.

Factors for volume F_M (Factor F_M = volume per 1 m³)

Volumetric unit	Text examples	Factor F _M	Setting
Cubic metres	m ³	1.0	1.00000 E+0
Litres	Liter	1 000	1.00000 E+3
Hectolitres	h Lit	10	1.00000 E+1
Decilitres	d Lit	10 000	1.00000 E+4
Centilitres	c Lit	100 000	1.00000 E+5
Millilitres	m Lit	1 000 000	1.00000 E+6
US gallons	USGal	264.172	2.64172 E+2
Millions US gallons	USMG	0.000264172	2.64172 E-4
Imperial gallons	GBGal	219.969	2.19969 E+2
Mega imperial gallons	GBMG	0.000219969	2.19969 E-4
Cubic feet	Feet3	35.3146	3.53146 E+1
Cubic inches	inches3	61 024.0	6.10240 E+4
US barrels, liquid	US BaL	8.36364	8.38364 E+0
US barrels, ounces	US BaO	33 813.5	3.38135 E+4

Factors for time F_T (Factor F_T in seconds)

Time unit	Text examples	Factor F _T (seconds)	Setting
Seconds	Sec	1	1.00000 E+0
Minutes	min	60	6.00000 E+1
Hours	hr	3 600	3.60000 E+3
Day	DAY	86 400	8.64000 E+4
Year (= 365 days)	YR	31 536 000	3.15360 E+7

5.13 F/R mode, forward / reverse flow measurement

- Refer to Sect. 2.3 for electrical connection of the outputs.
- Define direction of forward (normal) flow, see Fct. 3.2, subfunction "FLOW DIR.":
in conjunction with F/R operation, set the direction for the forward flow here.
"+" signifies the same direction as shown by the arrow on the primary head, "-" signifies the opposite direction.
- Set the status indication output to "F/R INDIC.", see Fct. 1.7.
- Set the current and / or pulse output to "2 DIR.", see Fct. 1.5 and 1.6, subfunctions "FUNCTION I" and "FUNCTION P".

5.14 Characteristic of outputs

- P** Pulse output
P_{100%} Pulses at Q_{100%}, full-scale range
- Q_F** 1 flow direction, or forward flow in F/R mode
Q_R Reverse flow in F/R mode
Q_{100%} Full-scale range

1 direction of flow

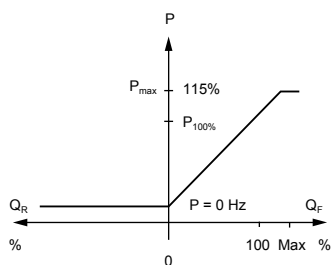

2 directions of flow F/R mode

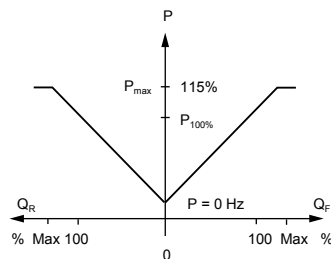

Part C Special applications, functional checks and service

6 Special applications

Please note!

Do not open the housing of the BATCHFLUX IFM 5015 K.

Danger of contamination with substances likely to destroy the moisture barrier of the electronic equipment (e.g. if CIP or SIP cleaned from the outside).

Therefore, please contact your KROHNE Service engineer before you open the housing.

6.1 RS 232 adapter and KROHNE software (option)

For operator control of the signal converter with MS-DOS PC, an RS 232 adapter (on request, with Imo monitor software) is available as an option. Detailed directions for use of the software are included.

Switch off power source before opening the housing !

- 1) Detach the 4 hex. screws and remove cover.
- 2) Plug the RS 232 adapter into the IMoCom jack on the printed circuit board of the signal converter (see Sect. 9), and connect to PC or laptop.
- 3) Switch on the power.
- 4) As described in the CONFIG directions, change data, parameters and measured values and/or have them called up for display.
- 5) Switch off the power.
- 6) Remove the RS 232 adapter from the amplifier board.
- 7) Replace the cover and tighten down the 4 screws.

Please refer to Sect. 3.2 "Factory settings".

6.2 Operation via HHT 010 hand-held terminal (option)

The HHT 010 hand-held terminal is available as an option for operation of the signal converter.

Switch off power source before opening the housing !

- 1) Detach the 4 hex. screws and remove cover.
- 2) Plug the HHT 010 connector into the IMoCom jack on the printed circuit board of the signal converter, see Sect. 9.
- 3) Power the unit.
- 4) Change data, parameters and measured values as described in Sect. 4 and 5 of these Instructions, and display.
- 5) Disconnect from power.
- 6) Detach HHT connector from the mother board.
- 7) Replace cover and tighten down the 4 screws with a torque of max.2 Nm.

Please refer to Sect. 3.2 "Factory settings".

7 Functional checks

7.1 Zero check with signal converter IFC 015

Please note!

Do not open the housing of the BATCHFLUX IFM 5015 K.

Danger of contamination with substances likely to destroy the moisture barrier of the electronic equipment (e.g. if CIP or SIP cleaned from the outside).

Therefore, please contact your KROHNE Service engineer before you open the housing.

Switch off power source before opening the housing

- Set “**zero**“ flow in the pipeline, but make sure that the **measuring tube** is **completely filled** with fluid.
- Switch on the system and wait 15 minutes.
- Press the following keys for zero measurement

Key	Displayed	Description
→		If “YES“ is set under Fct. 3.4 ENTRY CODE, key-in the 9-keystroke CODE 1: → → → ↵ ↵ ↵ ↑ ↑ ↑
	Fct. 1.0 OPERATION	
2x ↑	Fct. 3.0 INSTALL.	
→	Fct. 3.1 LANGUAGE	
2x ↑	Fct. 3.3 ZERO SET	
→	CALIB. NO	
↑	CALIB. YES	
↵	0.00 ----- / ---	Flowrate set in displayed unit, see Fct. 1.4 DISPLAY, subfunction “DISP.FLOW“.
		Zero measurement in progress, duration approx. 10 seconds.
		When flow “> 0“, “WARNING“ notice appears, confirm with key ↵ .
	STORE NO	If new value not to be stored, press key ↵ (3x) 4x = return to measuring mode.
↑	STORE YES	
↵	Fct. 3.3 ZERO SET	Store new zero value.
(2x) 3x ↵	----- ----- / ---	Measuring mode with new zero.

7.2 Test of measuring range Q, Fct. 2.1

Please note!

Do not open the housing of the BATCHFLUX IFM 5015 K.

Danger of contamination with substances likely to destroy the moisture barrier of the electronic equipment (e.g. if CIP or SIP cleaned from the outside).

Therefore, please contact your KROHNE Service engineer before you open the housing.

Switch off power source before opening the housing

- For this test a measured value can be simulated in the range of -110 to +110 percent of $Q_{100\%}$ (for set full-scale range see Fct. 1.1 FULL SCALE).
- Power the system.
- Press the following keys for this test:

Keys	Displayed	Description
→		If "YES" is set under Fct. 3.4 ENTRY CODE, key-in the 9-keystroke CODE 1: → → → ↓ ↓ ↓ ↑ ↑ ↑
	Fct. 1.0	OPERATION
↑	Fct. 2.0	TEST
→	Fct. 2.1	TEST Q
→		SURE NO
↑		SURE YES
↓	0	PERCENT
	± 10	PERCENT
↑ or ↓	± 50	PERCENT
	± 100	PERCENT
	± 110	PERCENT
↓	Fct. 2.1	TEST Q
		End of test; actual measured values again present at outputs.
(2x) 3x ↓	-----	----- / ---
		Measuring mode

7.3 Hardware information and error status, Fct. 2.2

Please note!

Do not open the housing of the BATCHFLUX IFM 5015 K.

Danger of contamination with substances likely to destroy the moisture barrier of the electronic equipment (e.g. if CIP or SIP cleaned from the outside).

Therefore, please contact your KROHNE Service engineer before you open the housing.

Switch off power source before opening the housing

- Before consulting the factory about errors/faults or flow measurement problems, please invoke Fct. 2.2 HARDW. INFO (hardware information).
- An 8-character and a 10-character status code are stored under this function in each of 3 "windows". These 6 status codes will enable rapid and simple diagnosis of your compact flowmeter.
- Power the system.
- Press the following keys for display of the status codes:

Key	Displayed		Description
→			If "YES" is set under Fct. 3.4 ENTRY CODE, key-in the 9-keystroke CODE 1: → → → ↵ ↵ ↵ ↑ ↑ ↑
	Fct. 1.0	OPERATION	
↑	Fct. 2.0	TEST	
→	Fct. 2.1	TEST Q	
↑	Fct. 2.2	HARDW. INFO	
→	→ MODUL ADC	-----	1st window
		-----	<u>Sample status code</u>
↵	→ MODUL I/O	-----	2nd window
		-----	3.25105.02 (8-character code, 1st line)
		-----	3A47F01DB1 (10-character code, 2nd line)
↵	→ MODUL.DISP.	-----	3rd window

PLEASE NOTE DOWN ALL 6 STATUS CODES !			
↵	Fct. 2.2	HARDW. INFO	End of hardware information
(2x) 3x ↵	-----	----- / ---	Measuring mode

If you need to return your flowmeter to KROHNE, please refer to the last-but-one page of these Instructions !

8 Service

Please note!

Do not open the housing of the BATCHFLUX IFM 5015 K.

Danger of contamination with substances likely to destroy the moisture barrier of the electronic equipment (e.g. if CIP or SIP cleaned from the outside).

Therefore, please contact your KROHNE Service engineer before you open the housing.

8.1 Important advice for removing the flowmeter from the pipeline – PLEASE NOTE

Attention is drawn to the following points to ensure reliable and proper dismantling of the flowmeter:

- Switch off the **power source** before dismantling the flowmeter.
- **Shut off the flow through the pipeline.**
- **Drain the pipes** upstream and downstream of the flowmeter.
- **Support** the ends of the pipes on both sides of the flowmeter when installed in a long and freely suspended section of the pipeline.
- **Shut off any compressed air supplies** used.
- **Drip pans or similar receptacles should be kept ready** and used to collect any residual liquids in the pipe system when dismantling the flowmeter.

8.2 Removal from the pipe system

- Detach power line from attachment plug (8) on signal converter housing.
- Disconnect grounding wire from U-clamp terminal (9) on converter housing.
- Detach status indication wire (option) from attachment plug (7).
- Remove air supply line: unscrew union nut from connection (6).
- Detach nuts from stud bolts (14).



Caution: risk of injury!

The pipe system can contract or extend when the flowmeter is removed. The pipeline must be relieved of stresses before the flowmeter is removed.

- Hold the flowmeter firmly. Pull out the stud bolts (14). Pull the pipe flanges slightly apart and remove the flowmeter.

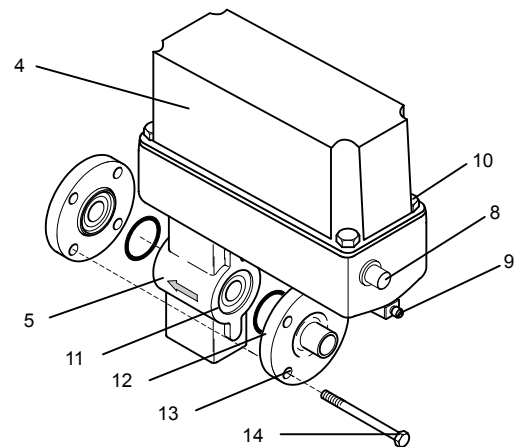

- 4 Cover, signal converter
- 5 Primary head
- 8 Plug connector power supply and pulse output (optional and status output)
- 9 U-clamp terminal for functional ground
- 10 Fastening screws for cover
- 11 Guide collar, primary head
- 12 O-ring gasket
- 13 Special pipe flange
- 14 Stud bolt with lock washer, plain washer and nut



Notes

9 Illustration of printed circuit board

Please note!

Do not open the housing of the BATCHFLUX IFM 5015 K.

Danger of contamination with substances likely to destroy the moisture barrier of the electronic equipment (e.g. if CIP or SIP cleaned from the outside).

Therefore, please contact your KROHNE Service engineer before you open the housing.

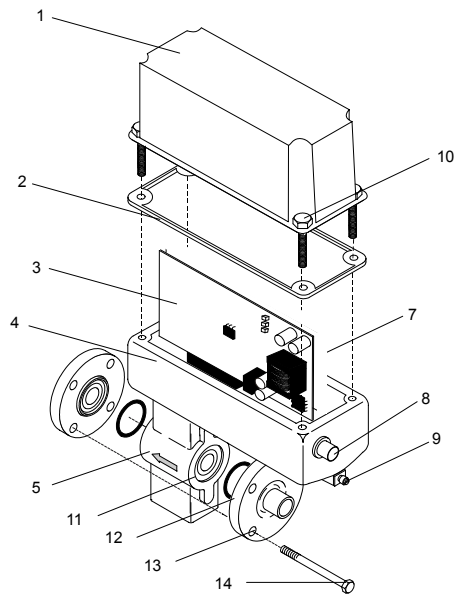

- 1 Cover, signal converter
- 2 Gasket
- 3 Electronic unit, signal converter
- 4 Housing, signal converter
- 5 Primary head
- 7 Printed circuit board
- 8 Plug connector power supply and pulse output
- 9 U-clamp terminal for functional ground
- 10 Fastening screws for cover
- 11 Guide collar, primary head
- 12 O-ring gasket
- 13 Special pipe flange
- 14 Stud bolt with lock washer, plain washer and nut

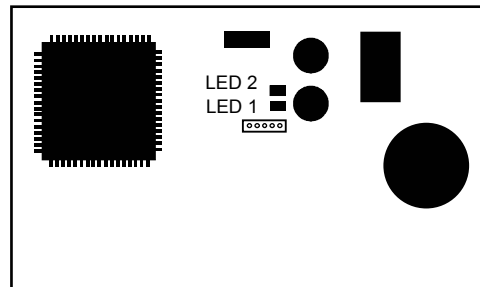

Part D Technical Data, block diagram and measuring principle

10 Technical data

10.1 Flow during filling, and fill volume

Meter size		Optimum flowrate for filling		Filling times > 1.5 s, filling volume	
DN mm	inches	ml/s	US Gal/min	ml	US Gal
2.5	1/10	3 - 10	0.048 - 0.159	≥ 10	≥ 0.003
4	1/8	10 - 30	0.159 - 0.476	≥ 20	≥ 0.005
6	1/4	20 - 60	0.317 - 0.951	≥ 40	≥ 0.011
10	3/8	60 - 200	0.951 - 3.170	≥ 100	≥ 0.026
15	1/2	150 - 500	2.378 - 7.925	≥ 200	≥ 0.053
25	1	400 - 1200	6.340 - 19.020	≥ 600	≥ 0.159
32	1 1/4	650 - 2250	10.300 - 35.663	≥ 975	≥ 0.257
40	1 1/2	1000 - 3000	15.850 - 47.551	≥ 1500	≥ 0.396

10.2 Flowmeter

Meter sizes	with venturi measuring tube DN 2.5, 4, 6, 10, 15, 25, 40 and 1/10", 1/8", 1/4", 3/8", 1/2", 1", 1 1/2"	
	with straight tube (option) DN 15, 32 and 1/2", 1 1/4"	
Connection	sandwich (flangeless) type with precisely defined sealing faces, centering devices and metallic stop face	
Electrical conductivity	≥ 5 µS/cm (≥ 20 µS/cm for demineralized cold water)	
Ambient temperature	-25 to +40 °C / -13 to +104 °F	
	-25 to +60 °C / -13 to +140 °F	
Process temperature	-60 to +140 °C / -76 to +356 °F	
	-60 to + 60 °C / -76 to +140 °F (information on higher provided on request) steam cleaning up to +150 °C / +302 °F	
Temperature shock resistance	<u>Temperature rising</u>	<u>Temperature falling</u>
sudden change	ΔT = 120 °C = 248 °F	ΔT = 90 °C = 194 °F
Temperature gradient	1 K/s	
Operating pressure	40 bar / 580 psig, dependent on gaskets used (10 bar / 145 psig for DN 15, 32 and 1/2", 1 1/4" with straight measuring tube)	
Electrode design	fused-in-place electrodes	
Protection category (EN 60 529/IEC 529)	IP 67, equivalent to NEMA 6 (overall device, incl. signal converter)	
Materials of construction		
Housing	stainless steel 1.4408 or 1.4404	
Measuring tube	fine-grain-stabilized, high-density HiTec ceramics, purity 99.7 % Al ₂ O ₃ (+ZrO ₂), CIP- and SIP-proof	
Electrodes	Cermet	
Cover seal	EPDM	

10.3 Signal converter

Low-flow cutoff	adjustable, cutoff 'on' value: 1 - 19 % cutoff 'off' value: 2 - 20 %
Power supply	
Voltage	24 V DC, ± 25% (18-30 V DC)
Power consumption	≤ 3 W
Electrical connection	M 12 plug-in connector
Operator control	All operating data factory-set to your specifications. Available as option for change of operating data: - HHT 010 hand-held terminal <u>or</u> - KROHNE software for operator control via PC. Options connected to the IMoCom interface
Pulse output	passive circuit
Function	All operating data factory-set to your specifications, connection of electronic totalizers, digital pulse division, interpulse period non-uniform, therefore if frequency meters counters connected, allow for minimum counting interval: gate time, counter $\geq \frac{1000}{P_{100\%}[\text{Hz}]}$
Pulse rate for Q = 100%	max. 10 kHz, fixed or optionally in pulses per m ³ , litres, US gallons, or in user-defined unit
Pulse width	≤ 10 Hz: 50, 100, 200 or 500 ms > 10 Hz: • automatic, pulse width = $\frac{1}{2 \times f_{100\%}}$ • symmetrical 1:1
Passive mode	external voltage: $U_{\text{ext}} \leq 30 \text{ V DC} / \leq 24 \text{ V AC}$ load rating: $I_{\text{max}} \leq 20 \text{ mA}$

10.4 Error limits at reference conditions

F = Error in % of MV

MV = measured value

Pulse output at flow velocity of ...	DN 2.5 – 6 / $1/10''$ – $1/4''$	DN 10 – 40 / $3/8''$ – $1 1/2''$
	$v \geq 1 \text{ m/s} \geq 3.3 \text{ ft/s}$	$F < \pm 0.5 \% \text{ of MV}$
$v < 1 \text{ m/s} < 3.3 \text{ ft/s}$	$F < \pm 0.4 \% \text{ of MV} + 1 \text{ mm/s}$ $< \pm 0.4 \% \text{ of MV} + 0.04 \text{ inch/s}$	$F < \pm 0.2 \% \text{ of MV} + 1 \text{ mm/s}$ $< \pm 0.2 \% \text{ of MV} + 0.04 \text{ inch/s}$
Repeatability	<u>Filling time T_F</u>	<u>Standard deviation σ</u>
	$1.5 \text{ s} < T_F \leq 3 \text{ s}$	$\leq 0.4 \%$
	$3.0 \text{ s} < T_F \leq 5 \text{ s}$	$\leq 0.2 \%$
	$5.0 \text{ s} < T_F$	$\leq 0.1 \%$

Reference conditions (similar to EN 29 104)

Liquid product	water +20 °C / +68 °F
Straight inlet/outlet runs	10× DN / 5 × DN (DN = meter size)
Valve closing time variation	< 1 ms
Flow velocity	1 m/s = 3.3 ft/s

Volumetrically wet calibration on EN 17025 accredited calibration rigs.

10.5 Dimensions and weights

in mm (inches)

DN 2.5 – 15 / $\frac{1}{10}$ " – $\frac{1}{2}$ "

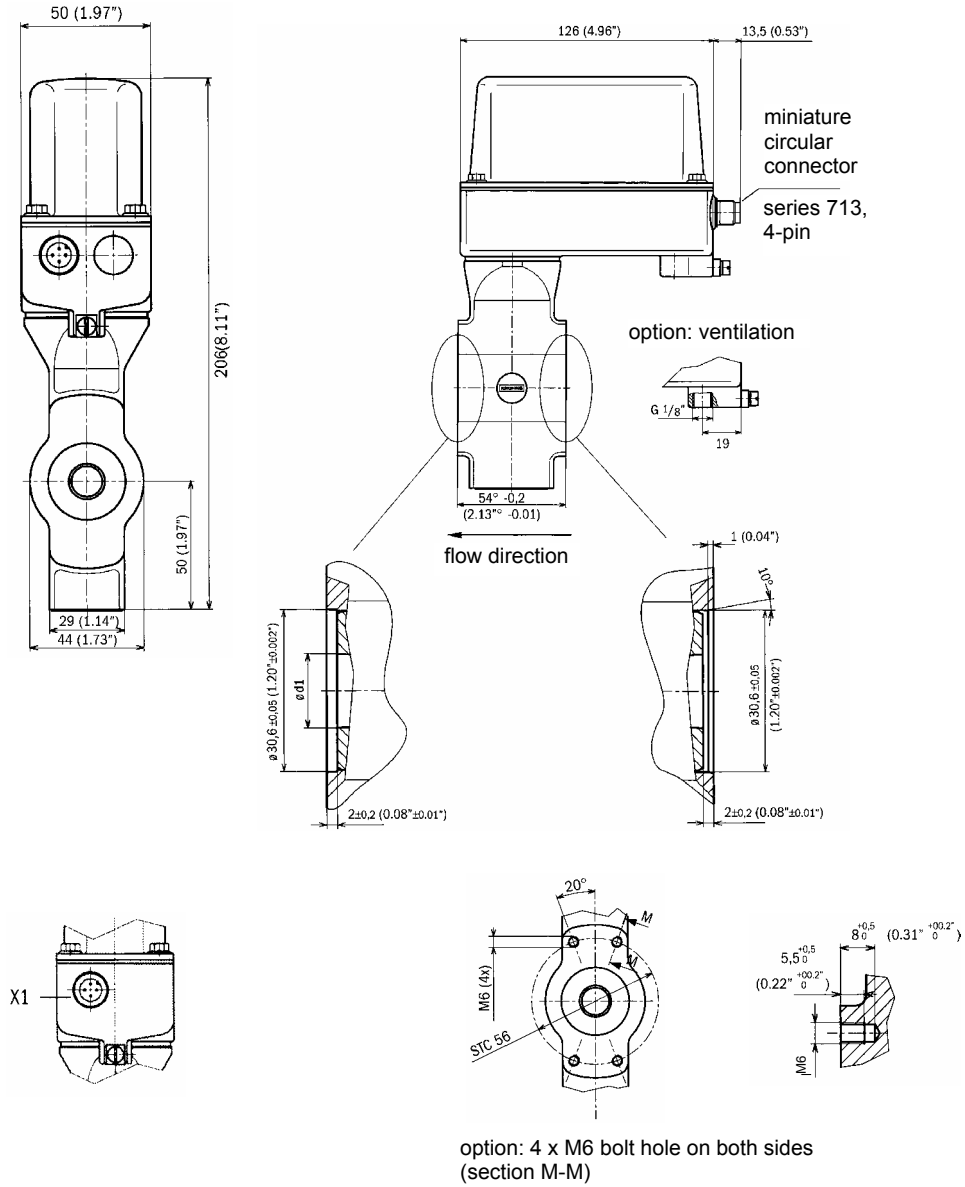

Meter size		Diameter d_1		Weight	
DN	inches	mm	(inches)	kg	lb
2.5	$\frac{1}{10}$	6	(0.24)	1.6	(3.6)
4	$\frac{1}{6}$	7	(0.28)	1.6	(3.6)
6	$\frac{1}{4}$	9	(0.35)	1.6	(3.6)
10	$\frac{3}{8}$	12	(0.47)	1.6	(3.6)
15	$\frac{1}{2}$	14.3	(0.56)	1.6	(3.6)

DN 25 – 40 / 1" – 1½"

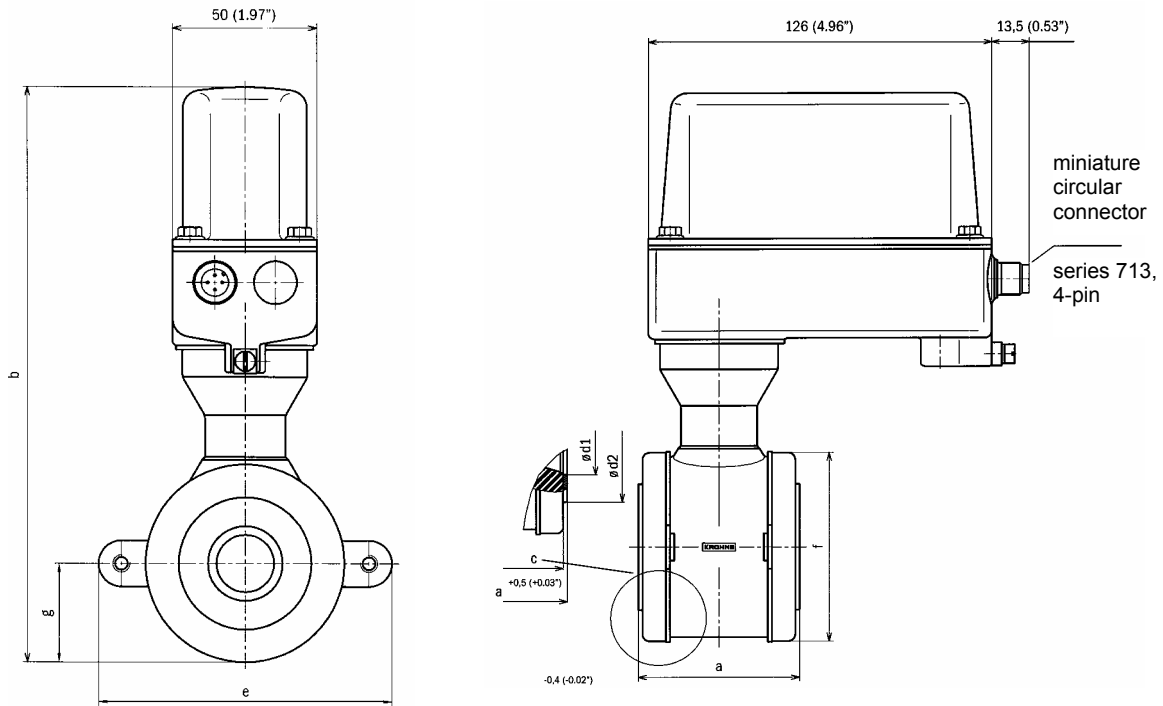

Meter size		Dimensions in mm (inches)							Weight	
DN	inches	a	b	f	g			kg	(lb)	
25	1	58 (2.28)	200 (7.87)	66 (2.68)	34 (1.34)			1.6	(3.6)	
32	1 ¼	83 (3.27)	215 (8.46)	81 (3.19)	42 (1.65)			2.3	(5.1)	
40	1½	83 (3.27)	215 (8.46)	81 (3.19)	42 (1.65)			2.3	(5.1)	

10.6 Instrument nameplates

Type designation
Serial No.
Insulation class of field coils
Protection category to IEC529/EN60529

KROHNE Holland IFM 5015 K / B / 2
Altometer A99 14900 ISO KL.E IP67 28-03

Pressure rating/flange class
Electrode material: platinum
Measuring tube material: Al₂O₃ aluminium oxide
Meter size: DN mm and inches

Measuring range
Primary constant

Q: 0- .5 l/s GK: --- GKL: 4.183 GKH: ---
P: 0-100 Hz

Tag:

11 Block diagram

The IFC 015 signal converter consists of 3 functional groups.

Functional group 1 contains an input amplifier, and a high-resolution analog/digital converter (ADC) that is controlled and monitored by microprocessor $\mu P1$. At the same time the processor controls functional groups 2 and 3. The function values of the device are stored in EEPROM 1 (ECOPROM), while all internal correction and calibration values are stored in EEPROM 2.

Functional group 2 generates a pulsed, electronically controlled direct current for the field coils of the primary head. This group is electrically connected to functional group 3.

Functional group 3 consists of passive FET optocouplers to allow control of electronic and electromechanical totalizers. This group is electrically separated from the other groups.

1/2/3	signal inputs
7/8	field coils
IMoCom bus	for connection of add-on devices, see Sect. 6
P	pulse output
	≤ 10.000 pulses/s (=Hz)

Block diagram IFC 015

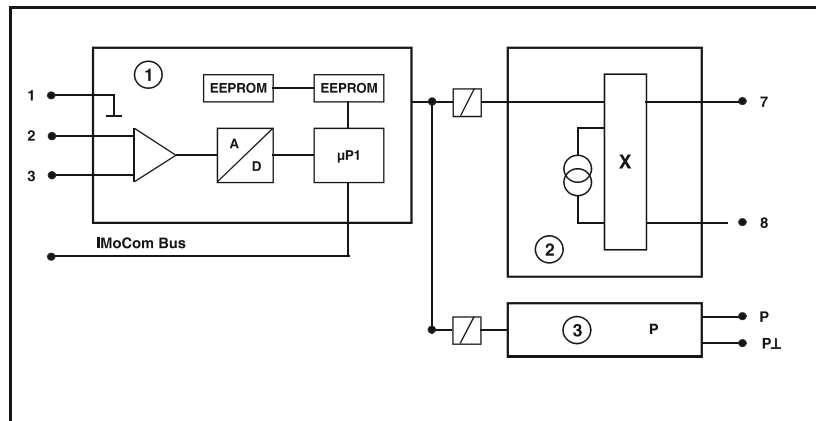

12 Measuring principle

Flowmeter for electrically conductive liquids.

Measurement is based on Faraday's law of induction, according to which a voltage is induced in an electrically conductive body passing through a magnetic field.

The following expression applies:

$$U = K \times B \times \bar{v} \times D$$

K	an instrument constant
B	magnetic field strength
\bar{v}	mean velocity
D	tube diameter

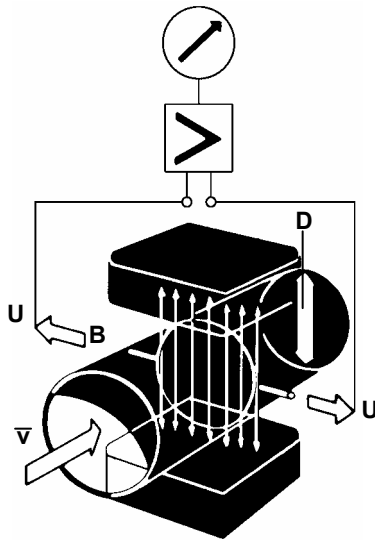

Thus, the induced voltage is proportional to the mean flow velocity, when the field strength is constant. Inside the electromagnetic flowmeter, the liquid passes through a magnetic field applied perpendicular to the direction of flow.

An electric voltage is induced by the movement of the liquid (which must have a minimum electrical conductivity), which is proportional to the mean flow velocity and thus to the volume of flow.

The induced voltage signal is picked up by two electrodes that are in conductive contact with the liquid, and transmitted to a signal converter for a standardized output signal.

Part E Annex

E.1 Index

Keyword	Section-No.	Fct-No.	Keyword	Section-No.	Fct-No.
A			Function of keys	4.1 - 4.3	
Abbreviations	4.4		Functional description	page 5	
ADC = analog/digital converter	4.5		Function(s)	4.4	
Ambient temperature	1.1.1, 10.6		Functional ground FE	1.3.3.2.1, 2.2	
Analog/digital converter = ADC	4.5		Function column	4.1,	
ANSI flanges	1.2		Functional check	7.1 ff	
			– hardware info	7.3	2.2
B			– zero	7.1	3.3
Block diagram IFC 015 K	12		– measuring range	7.2	
			Full-scale range Q100%	4.4, 5.1	1.1, 3.2
C			G		
Cable lengths	2.2		Gaskets	1.4.2, 10.3	
Cermet electrode	1.3.2		GKL values	4.4, 5.11	3.2
Characteristic	5.14		Grounding	1.3.3, 2.ff	
Check elements	4.2		Guide collar	1.4.2, 1.3.2	
Cleaning	1.1.1, 8.1				
Connection diagrams			H		
– outputs	2.3		Hand-held terminal HHT 010	4.2	
– power supply	2.2		Hardware info	7.3	2.2
Connection points					
– grounding	1.3.3		I		
– electricals (on housing)	1.4.1		I = current output	2.3.1, 5.6	1.5
Coding for Entry	5.11	3.4	IMoCom software	6.1	
CONFIG software	6.1		IMoCom bus (plug)	1.4.1	
Conversion factor			Impulses = pulses		
– volume	4.4, 5.12	3.5	Impulse output =		
– time	4.4, 5.12	3.5	pulse output P		
Current output I	2.3.1, 5.6	1.5	(frequency output)	2.3.2, 5.7	1.6
			Input		
D			– of entry code	5.11	3.4
Data	4.4		– programming	4	
–column	4.1-4.3		Installation of primary head	1.ff	
–error messages	4.5		Instrument nameplates	10.7	
Device description	1.4.1		Interface RS 232	6.1	
Deletion of error messages	4.6		internal electronic totalizer	5.5	1.4
DIN flanges	1.3.1, 1.4-1,		Interface adapter RS 232	6.1	
	10.4				
Display	4.2	1.4	K		
DN = meter size in mm	1.4, 5.5,	3.2	Keys	4.1 - 4.3	
	10.6,		Keystroke combinations for		
			– entry into setting level	4.1 - 4.3	3.4
E			– error cancelling	4.6	
Electrical connection			– quitting the setting level	4.1 - 4.3	
– outputs	2.3		– resetting totalizer(s)	4.6	
– power supply	2.2				
– status output	2.3.2		L		
– current output	2.3.2		Language of display texts	5.9	3.1
– pulse output	2.3.1		LCD display, see display	4.2, 4.4, 5.4	1.4
Electronic totalizer	5.4, 5.5	1.6	Limits	10.5	
Electrodes	10.2, 10.6		Liner	10.6	
EN Standards	1.1, 2.1		Liner / measuring section	10.2, 10.6	
Error List	4.5, 4.6		Line voltage, see power supply		
Errors	4.5		Low-flow cutoff	4.4 + 5.3	1.3
Error (messages)	4.5		Low-flow cutoff "off" value	5.3	1.3
– cancel	4.5				
– reset (delete)	4.6		M		
– diagnosis, see functional	7. ff		Main menus	4.1 - 4.3	1.0, 2.0,
check					3.0
			Main menu column	4.1	1.0, 2.0,
					3.0
F			Magnetic field frequency	4.4, 5.11	3.2
F = forward flow	4.4, 5.3	1.4 - 1.7	Materials of construction	10.2, 10.6	
Factory settings	3.2		Menu	4.1, 4.4	
Factor (time / volume)	5.12	3.5	Measuring principle	Page 5	
Fatal Error	4.5		Measuring tube	10.6	
FE = functional ground	1.3.3, 2.1		Metal pipeline, grounding of	1.3.3, 2.1	
Flange spacing (fitting dim."a")	1.3.1, 10.6,		Meter size (DN) = nominal dia.		
Flow (Q)	4.4, 5.1, 10.1	3.2	of measuring tube in mm or	4.4, 10.3,	3.2
Flow velocity v	4.4, 10.1, 5.1	3.2	inches	10.4	
Flow, direction of	4.4, 5.1.1	3.2			
Frequency output S					
– pulse output P	2.3.3, 4.4, 5.7	1.6			

Keyword	Section-No.	Fct-No.	Keyword	Section-No.	Fct-No.
N			S		
Number format of display	5.4, 5.5	1.4	S = status output	2.3.2, 4.4, 5.7	1.7
O			Safety conductor PE	1.2.3, 2.2	
Operating pressure	10.5		Scope of supply	1.3	
Option = add-on equipment = HHT 010	4.2, 6.1, 10.3-10.5,		Signalling cable A	1.3.4, 10.4	
Order numbers	9		Signal converter IFC 015		
Outputs			– connection, power	2.2	
– connection diagrams	2.3		– connection, HHT 010	4.2, 8.9	
– characteristic	5.14		– operator control	4.1 - 4.3	
– setting	4.4		– spare parts	9	
– I	5.6	1.5	– error limits	10.2	
– P	5.7	1.6	– functional checks	7.1 - 7.3,	
– S	5.8	1.7	– technical data	10.4	
Overflow display	5.5	1.4	SMU = low-flow cutoff	4.4, 5.3	1.3
P			Software	6.1	
P = pulse output	2.3.2, 4.4, 5.7	1.6	Special function = Option	6.1, 10.3-10.5	
PC software	6.1		Status indication output	5.8	
PCB = control electronics			Status output S	2.3, 4.4, 5.7	1.7
PE = protective conductor	1.3.3, 2.1, 2.2		Start-up	3	
Power supply (= line voltage)			Straight outlet run	1.1, 1.2	
– connection	2.2, 10.5		Straight inlet run	1.1, 1.2	
– failure	4.5, 7.4		Storage	1.1,	
– frequency	2.2, 10.5		Standards		
– power consumption	10.5		– ANSI ...	1.3, 10.3, 10.4, 10.6-10.8	
– voltage	2.2, 10.5		– DIN ...	1.2 10.3,10.4, 10.6-10.8	
– changeover	8.2		– EN ...	10.4	
Primary constant, see GKL	4.4, 5.11	3.2	– EMC	page 4	
Primary head	1.4.1		– IEC ...	1.1,1.3.3, 10.3-10.5, 10.9	
– installation	1.1 - 1.3		– VDE ...	1.3.3, 2.1, 2.1, 10.4	
– installation dimensions	1.3.1, 10.6		Submenu column	4.1 to 4.3	
Printed circuit boards, see PCB	8.9		T		
Process temperature	1.1, 10.5		T = time constant	5.2	1.2
Program organization	4.1		Technical data		
Programming area, entry into	4.1 - 4.3		– measuring section / liners	10.3	
Programming = input	4.1 - 4.3		– dimensions + weights	10.7, 10.8	
Protective rings	1.3.1		– error limits	10.2	
Pulse duration = pulse width	4.4, 5.7	1.6	– limits for liners	10.6	
Pulse output P / pulse width	4.4, 5.7	1.6	– signal converter IFC 015 K	10.2, 10.4	
Pulses per unit volume/time	4.4, 5.7	1.6	– primary head	10.5	
Q			Temperatures		
Q = flowrate	4.4 + 5.1	1.1, 3.2	– process product	10.3, 10.4, 10.6	
Q100% = full-scale range	4.4 + 5.1	1.1, 3.2	– ambient	10.2 - 10.4	
R			Tests, see functional checks	7.1, 7.2	
R = reverse flow	4.4, 5.13	1.4 - 1.7	Time constant (T)	5.2	1.2
Range setting	4.4, 5.1	3.1.1, 3.1.2	Torques	1.3, 1.4.2	
Removal of			Totalizer (internal electronic)	5.7	1.6
– control electronics	8.3		Transport	1.1.1	
– device (total)	1.4.2, 8.2		U		
Reset totalizer	4.6		Unit		
Return to			– display	4.4, 5.4	1.4
– functions column	4.1 - 4.3		– flow	4.4, 5.1	1.1
– main menu column	4.1 - 4.3		– pulse output	4.4, 5.7	1.6
– measuring mode	4.1 - 4.3		User-definable unit	4.4, 5.12	3.5
– submenu column	4.1 - 4.3		V		
Reverse flow (R)	4.4, 5.13	1.4 - 1.7	v = flow velocity	4.4 + 5.1	3.2
RS 232 adapter	6.1		Volumetric unit	5.12	3.5
			Z		
			Zero check (adjustment)	7.1	3.3

E.2 Form to accompany returned device

If you need to return flowmeters for testing or repair to KROHNE

Your electromagnetic flowmeter

- has been carefully manufactured and tested
- and volumetrically calibrated in one of the world's most accurate test rigs.

If installed and operated in accordance with these operating instructions, your flowmeter will rarely present any problems.

Should you nevertheless need to return a flowmeter for checkout or repair, please pay strict attention to the following points:

Due to statutory regulations concerning protection of the environment and safeguarding the health and safety of our personnel, Krohne may only handle, test and repair returned flowmeters that have been in contact with liquids if it is possible to do so without risk to personnel and environment.

This means that KROHNE can only service your flowmeter if it is accompanied by a certificate in line with the following model confirming that the flowmeter is safe to handle.

If the flowmeter has been operated with toxic, caustic, flammable or water-endangering liquids, you are kindly requested

- to check and ensure, if necessary by rinsing or neutralizing, that all cavities in the flowmeter are free from such dangerous substances.
(Directions on how you can find out whether the primary head has to be opened and flushed out or neutralized are obtainable from KROHNE on request.)
- to enclose a certificate with the flowmeter confirming that the flowmeter is safe to handle and stating the liquid used.

KROHNE regret that they cannot service your flowmeter unless it is accompanied by such a certificate.

Printed Form sheet (suitable for copying)

Company: Address:

Department: Name:

Tel. No.:

The enclosed electromagnetic flowmeter

Type: KROHNE Order No. or Series No.:

has been operated with the following process liquid

Because this process liquid is
water-endangering * / toxic * / caustic * / flammable *
we have

- checked that all cavities in the flowmeter are free from such substances *
 - flushed out and neutralized all cavities in the flowmeter *
- (* delete where not applicable)

We confirm that there is **no** risk to man or environment through any residual liquid contained in the flowmeter.

Date: Signature:

Company stamp:

<http://www.krohne.com>

Production

KROHNE

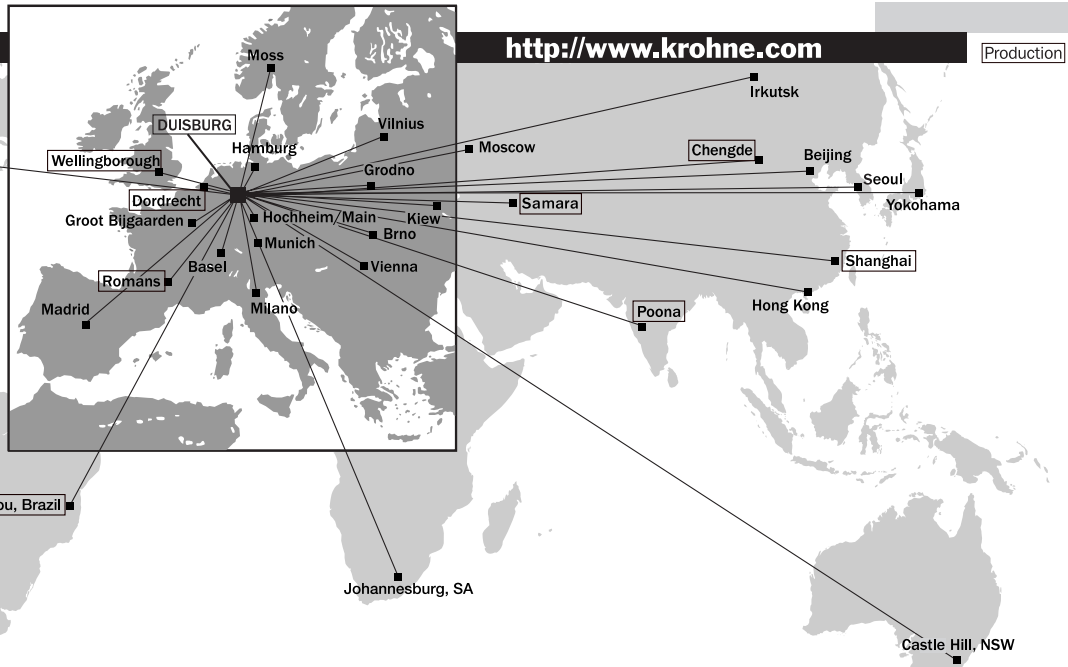

Australia

KROHNE Australia Pty Ltd.
Unit 19 No. 9, Hudson Ave.
Castle Hill 2154, NSW
TEL: +61(0)2-98948711
FAX: +61(0)2-98994855
e-mail: krohne@krohne.com.au

Austria

KROHNE Ges.m.b.H. Austria
Modecenterstraße 14
A-1030 Wien
TEL: +43(0)1-2 03 45 32
FAX: +43(0)1-2 03 47 78
e-mail: info@krohne.at

Belgium

KROHNE Belgium N.V.
Brusselstraat 320
B-1702 Groot Bijgaarden
TEL: +32(0)2-4 66 00 10
FAX: +32(0)2-4 66 08 00
e-mail: krohne@krohne.be

Brazil

KROHNE Conaut
Controles Automaticos Ltda.
Estrada Das Águas Espraiadas, 230 C.P.56
06835 - 080 EMBU - SP
TEL: +55(0)11-4785-2700
FAX: +55(0)11-4785-2768
e-mail: conaut@conaut.com.br

China

KROHNE Measurement Instruments Co. Ltd.
Room 7E, Yi Dian Mansion
746 Zhao Jia Bang Road
Shanghai 200030
TEL: +86(0)21-64677163
FAX: +86(0)21-64677166
Cellphone: +86(0)139 1885890
e-mail: ksh@ihw.com.cn

CIS

Kanex KROHNE Engineering AG
Business-Centre Planeta, Office 403
ul. Marxistskaja 3
109147 Moscow/Russia
TEL: +7(0)095-9117165
FAX: +7(0)095-9117231
e-mail: krohne@dol.ru

Czech Republic

KROHNE CZ, spol. s r.o.
Soběšická 156
CZ-63800 Brno
TEL: +420 545 532 111
FAX: +420 545 220 093
e-mail: brno@krohne.cz

France

KROHNE S.A.
Usine des Ors
B.P. 98
F-26 103 Romans Cedex
TEL: +33(0)4-75 05 44 00
FAX: +33(0)4-75 05 00 48
e-mail: info@krohne.fr

Germany

KROHNE Messtechnik
GmbH & Co. KG
Ludwig-Krohne-Straße
D-47058 Duisburg
TEL: +49(0)203-301-0
FAX: +49(0)203-301-389
e-mail: krohne@krohne.de

India

KROHNE Marshall Ltd.
A-34/35, M.I.D.C.
Industrial Area, H-Block,
Pimpri Poona 411018
TEL: +91(0)20-744 20 20
FAX: +91(0)20-744 20 40
e-mail: pcu@vsnl.net

Italy

KROHNE Italia Srl.
Via V. Monti 75
I-20145 Milano
TEL: +39(0)2-4 30 06 61
FAX: +39(0)2-43 00 66 66
e-mail: krohne@krohne.it

Korea

Hankuk KROHNE
2 F, 599-1
Banghwa-2-Dong
Kangseo-Ku
Seoul
TEL: +82(0)2665-85 23-4
FAX: +82(0)2665-85 25
e-mail: flowtech@unitel.co.kr

Netherlands

KROHNE Altometer
Kerkeplaat 12
NL-3313 LC Dordrecht
TEL: +31(0)78-6306300
FAX: +31(0)78-6306390
e-mail: postmaster@krohne-altometer.nl

Netherlands

KROHNE Nederland B.V.
Kerkeplaat 12
NL-3313 LC Dordrecht
TEL: +31(0)78-6306200
FAX: +31(0)78-6306405
Service Direkt: +31(0)78-6306222
e-mail: info@krohne.nl

Norway

Krohne Instrumentation A.S.
Ekholtveien 114
NO-1526 Moss
P.O. Box 2178, NO-1521 Moss
TEL: +47(0)69-264860
FAX: +47(0)69-267333
e-mail: postmaster@krohne.no
Internet: www.krohne.no

South Africa

KROHNE Pty. Ltd.
163 New Road
Halfway House Ext. 13
Midrand
TEL: +27(0)11-315-2685
FAX: +27(0)11-805-0531
e-mail: midrand@krohne.co.za

Spain

I.I. KROHNE Iberia, S.r.L.
Poligono Industrial Nilo
Calle Brasil, nº. 5
E-28806 Alcalá de Henares-Madrid
TEL: +34(0)91-8 83 21 52
FAX: +34(0)91-8 83 48 54
e-mail: krohne@krohne.es

Switzerland

KROHNE AG
Uferstr. 90
CH-4019 Basel
TEL: +41(0)61-638 30 30
FAX: +41(0)61-638 30 40
e-mail: info@krohne.ch

United Kingdom

KROHNE Ltd.
Rutherford Drive
Park Farm Industrial Estate
Wellingborough,
Northants NN8 6AE, UK
TEL: +44(0)19 33-408 500
FAX: +44(0)19 33-408 501
e-mail: info@krohne.co.uk

USA

KROHNE Inc.
7 Dearborn Road
Peabody, MA 01960
TEL: +1-978 535-60 60
FAX: +1-978 535-17 20
e-mail: krohne@krohne.com

Overseas Representatives

Algeria	Japan
Argentina	Jordan
Bulgaria	Kuwait
Cameroon	Marocco
Canada	Mauritius
Chile	Mexico
Columbia	New Zealand
Croatia	Pakistan
Denmark	Poland
Ecuador	Portugal
Egypt	Saudi Arabia
Finland	Senegal
French Antilles	Singapore
Greece	Slovakia
Guinea	Slovenia
Hong Kong	Sweden
Hungary	Taiwan
Indonesia	Thailand
Ivory Coast	Turkey
Iran	Tunisia
Ireland	Venezuela
Israel	Yugoslavia

Other Countries:

KROHNE Messtechnik
GmbH & Co. KG
Ludwig-Krohne-Str.
D-47058 Duisburg
TEL: +49(0)203-301 309
FAX: +49(0)203-301 389
e-mail: export@krohne.de