

Installation and operating instructions (Reference Manual)

Level Radar BM 70 A / BM 70 P

Non-contact level gauging
using electromagnetic waves



Variable area flowmeters

Vortex flowmeters

Flow controllers

Electromagnetic flowmeters

Ultrasonic flowmeters

Mass flowmeters

Level measuring instruments

Communications engineering

Engineering systems & solutions

Contents:

General advice on safety	3	8. User interface	35
Product liability and warranty	3	8.1 Local display	35
Items included with supply	3	8.2 Function of the keys	36
Software history	4	8.3 Operator control concept	37
1. Range of application	6	8.4 Table for settable functions (Version 3.00, 3.03, 4.02, 4.03)	39
2. Mode of operation and system structure.	6	8.5 Configuration examples.....	42
2.1 Operating principle	6	8.6 Description of functions	44
2.2 Signal processing (digital)	7	8.7 Functional checks.....	55
2.3 Modularity (signal converter, flange, antenna).....	7	8.8 Pointers and error messages during measurements.....	56
3. Input.....	8	8.9 Messages on start-up.....	58
3.1 Measured variable (distance, level, volume, reflection)	8	8.10 Faults and symptoms during start-up and measurement	58
3.2 Measuring range [0.5-35/40 m (1.64-115/131 ft)]	8	8.11 Calculation of the measured value	61
3.3 Block distance.....	8	8.12 User program PC-CAT for Windows	62
3.4 Out-of-range performance.....	8	9. Power supply	63
4. Output.....	9	9.1 Options, technical data.....	63
4.1 Variants.....	9	9.2 Fuses	63
4.2 Ex-e current output HART®	10	9.3 Changeover of operating voltage and replacement of fuses	63
4.3 Ex-i current output HART® (type of protection: Ex de [ia])	10	9.4 Advice on safety.....	64
4.4 HART® communication.....	11	10. Certificates and approvals.....	66
4.5 Current output (non-communicable)	11	10.1 Hazardous-duty approvals.....	66
4.6 Digital interface RS 485	11	10.2 Other approvals and certificates	66
4.7 Breakdown signal.....	13	10.3 Explosion proof acc. to ATEX	67
4.8 Digital input.....	13	10.4 Radio approval	68
5. Measuring accuracy.....	14	10.5 CE manufacturer's declaration.....	69
5.1 Reference conditions.....	14	11. Order information	70
5.2 Error of measurement	14	12. External standards, codes and directives	71
5.3 Repeatability	15	13. Quality assurance	71
5.4 Measured value resolution/hysteresis	15	Annex	
5.5 Transient recovery time	16	Annex A: Technical Data	72
5.6 Turn-on drift / turn-on characteristics	16	Annex B: Type code / nameplates.....	74
5.7 Long-term drift	16	Annex C: Spare parts	77
5.8 Effect of ambient temperature	16	Annex D: Signed declaration to accompany a device returned to KROHNE	80
6. Operating conditions	17	Annex E: Table on documentation of device configuration.....	81
6.1 Installation conditions	17	Annex F: Index.....	82
6.2 Ambient conditions.....	25		
6.3 Product conditions.....	26		
6.4 Maintenance	27		
7. Design.....	28		
7.1 Models	28		
7.2 Dimensions and weights	29		
7.3 Replacement of the signal converter	30		
7.4 Field assembly	30		
7.5 Selection of antenna type and size.....	31		
7.6 Materials of construction	32		
7.7 Process connection	32		
7.8 Electrical connection	33		
7.9 Terminating resistor for the RS 485 interface	34		

General advice on safety:

- **To carry:** the device will weigh between approx. 16 kg (35.5 lb) and 30 kg (66.1 lb) or more! To carry, use both hands to lift the device carefully by the converter housing. If necessary, use lifting gear.
- When **handling** the BM 70 A/P, avoid hard blows, jolts, impacts, etc.

Product liability and warranty:

The BM 70 A/P level gauge is designed solely for measuring the distance, level, volume and reflection of liquids, pastes, slurries, solids and particulate materials.

The BM 70 A/P level gauge does not form part of an overfill protection system as defined in WHG.

Special codes and regulations apply to its use in hazardous areas.

Responsibility as to suitability and intended use of these level gauges rests solely with the user.

Improper installation and operation of our level gauges may lead to loss of warranty.

In addition, the "General conditions of sale", forming the basis of the purchasing contract, are applicable.

If you need to return the level gauge to the manufacturer or supplier, please refer to the information given in Annex D.

Items included with supply:

The scope of supply encompasses, in the version as ordered:

- Signal converter bolted to waveguide window and antenna
Optionally: antenna extension, sunshade (with fastening material in each case)
- Shielding material with strap retainer (not for the US market)
- Report on factory settings for the signal converter
- Bar magnet for operator control / parameter assignment (only in version with local display)
- Wrench for the covers

Installation material (stud bolts, flange gasket and cabling) not supplied, to be provided by customer!

Documentation supplied:

- **Condensed instructions:** installation, connection, start-up and safety advice in condensed form, but sufficient for most applications. Please read through these instructions first!
- **Instruction card:** overview of the configuration menu and meaning of the markers in cheque card format.
- **Installation and operating instructions** (this manual): detailed user manual and reference book, including description of special versions and functions. This documentation is structured on lines similar to those given in the DIN V 19259 Standard.
- **Approval documents**, unless reproduced in the installation and operating instructions.

Software history

Signal Converter Firmware

For BM 70 A:

Introduction Mth./Yr	Firmware Version	Device Instructions	Remarks
06/97	3.00PREnn	06/97	Test versions
01/98	3.00	11/97-11/00	First serial version. Errors when empty spectrum recorded with WAVE-STICK; automatic reset when signal is extremely weak.
05/98	3.01	11/97-11/00	Elimination of errors in V. 3.00; improved application of empty spectrum at tank bottom.
07/99	3.02	05/98-11/00	Implementation of the ModBus protocol; adaptation to PROFIBUS interface; improved application of empty spectrum at tank bottom; improvement of PC-CAT protocol switching in multidrop operation; definition of 3.6 mA as lower error current for the IS current output; improved tank bottom tracing; improved spectrum evaluation at tank heights > 15 m.
11/99	3.03	05/98-11/00	Correction of a bug in the mode "Hold on Error" (output current went to 1 mA or 3.6 mA; only V. 3.02); Adaption of the HART protocol for operation with the program AMS, and some smaller error corrections; Improved "tank bottom recognition" (measured value now always goes to the programmed tank bottom position); If no measured value is found after start-up, the instrument goes directly into "tank bottom recognition" and the local display to level = 0, if Fct. 3.2.5 Error Messages = NO is set.

For BM 70 P:

Introduction Mth./Yr	Firmware Version	Device Instructions	Remarks
05/98	4.00PREnn 4.01PREnn 4.02PREnn	05/98	Test versions
07/99	4.02	05/98-11/00	First serial version.
11/99	4.03	05/98-11/00	Correction of a bug in the mode "Hold on Error" (output current went to 1 mA or 3.6 mA; only V. 4.02); Adaption of the HART protocol for operation with the program AMS, and some smaller error corrections; Improved "tank bottom recognition" (measured value now always goes to the programmed tank bottom position); If no measured value is found after start-up, the instrument goes directly into "tank bottom recognition" and the local display to level = 0, if Fct. 3.2.5 Error Messages = NO is set.

Compatibility between PC-CAT Software and BM 70x Level-Radar Instruments

Software ⁽¹⁾	Operating System	I N S T R U M E N T S			
		BM 70 BM 70 Nautic	BM 70 A BM 70 P	BM 700	BM 702
PC-CAT (DOS) 1.00	DOS \geq 3.00	YES ⁽²⁾	NO	NO	NO
PC-CAT (DOS) 2.00 ⁽⁴⁾	DOS \geq 3.00	YES ⁽³⁾	NO	NO	NO
PC-CAT (DOS) 2.10/2.11 ⁽⁴⁾	DOS \geq 3.00	YES	NO	NO	NO
PC-CAT (DOS) 2.30	DOS \geq 5.00 ⁽⁷⁾	YES	Up to firmw. 3.02/4.02 ⁽⁵⁾	Up to firmw. 5.02 ⁽⁵⁾	NO
PC-CAT (DOS) 3.00	DOS \geq 5.00 ⁽⁷⁾	YES	Up to firmw. 3.02/4.02	Up to firmw. 5.02	NO
PC-CAT (DOS) 3.01	DOS \geq 5.00 ⁽⁷⁾	YES	YES	YES	YES ⁽⁶⁾
PC-CAT Windows 4.00/4.01	Windows 95,98,2000,NT	NO	YES	YES	YES
PC-CAT Windows Lite 4.01	Windows 95,98,2000,NT	NO	YES	YES	YES

⁽¹⁾ table is not including PRE versions of PC-CAT

⁽²⁾ limited to configuration parameters up to firmware 2.02/2.10

⁽³⁾ limited to configuration parameters up to firmware 2.20

⁽⁴⁾ Attention!! Does not run on fast PCs !!

⁽⁵⁾ with reduced display and configuration capability

⁽⁶⁾ not with firmware 7.00/PRE0x

⁽⁷⁾ or DOS-Window in Windows 3.1x, 9x (not Windows NT, 2000)

1 Range of application

The BM 70 A/P Level-Radar level gauging system is designed to measure the distance, level, volume and reflection of liquids, pastes, slurries, solids and particulate materials. It can be operated on storage and process tanks and also on stilling wells.

BM 70 P is specially designed for applications on storage tanks with highest precision requirements.

BM 70 A/P Ex hazardous-duty versions are suitable for use in Ex-Zone 0, 1 and 2.

In Germany (and, depending on the respective radio approval, in some other countries as well) its use is restricted to closed tanks or containers made of metal or concrete. Because of the low output involved, however, the microwaves are not harmful to human beings.

2 Mode of operation and system structure

2.1 Operating principle (FMCW-Radar)

A radar signal is given via an antenna, reflected on the measuring surface and received after a delay time t .

FMCW: Frequency Modulated Continuous Wave

The FMCW-radar uses a high frequency signal (~ 10 GHz) which transmit frequency increasing linearly 1 GHz during the measurement (frequency sweep) (1). The signal is emitted, reflected on the measuring surface and received time-delayed (2).

For further signal processing the difference Δf is calculated from the actual transmit frequency and the receive frequency (3). The difference is directly proportional to the distance i.e. a large frequency difference correspond to a large distance and vice versa.

The frequency difference is transformed via a Fourier transformation (FFT) into a frequency spectrum and then the distance is calculated from the spectrum. The level results from the difference between tank height and distance.

Linearity of frequency sweeps

The measuring accuracy of a FMCW radar is determined from the linearity of the frequency sweeps and their reproducibility. The linearity correction is deduced via reference measurement of the oscillator.

The non-linearity is corrected up to 98% (BM 700/BM 70 A).

An immediate frequency regulation is necessary with the BM 70 P device because of the higher demand on the measuring accuracy.

With the PLL technology (Phase Locked Loop) the signal frequency is directly recorded as a digital data and the converter oscillator locks automatically on the right frequency.

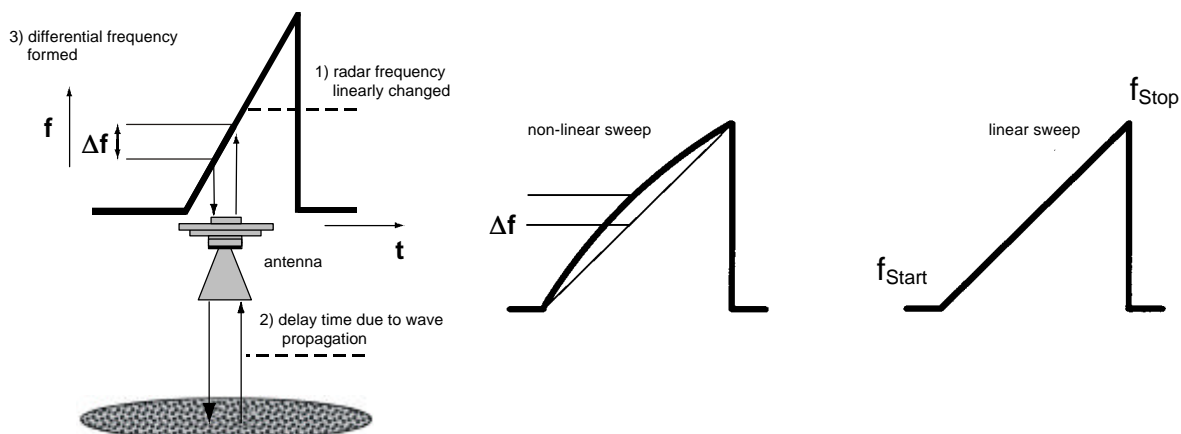

As the transmit frequency is changed during a short time interval by FMCW radar the transmitted frequency has to follow the nominal frequency within micro seconds. This ensues via modern, fast electronic and processors.

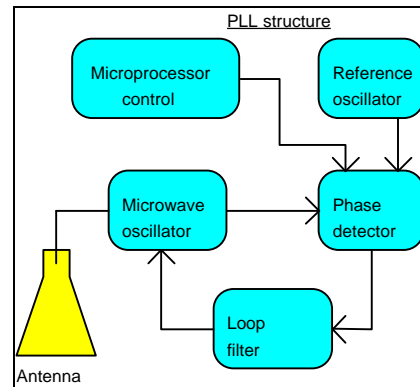

2.2 Signal processing (digital)

The radar signals are digitally processed by a microprocessor. The processing system is based on intelligent procedures that allow for plausibilities and history.

The following diagram describes the path of internal signal processing:

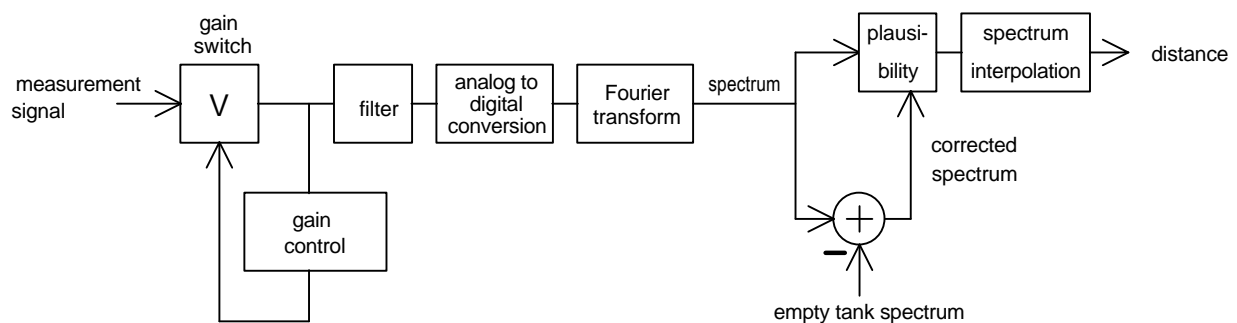

After automatic gain control, the measuring signal is filtered, digitized and converted into a frequency spectrum by means of the Fourier transform. Plausibility of the value obtained is assessed with the aid of the so-called empty-tank spectrum, which contains information about constant interference reflectors. Interpolation of the spectrum helps to improve resolution of the measured value.

2.3 Modularity (signal converter, flange, antenna)

The measuring system consists of the flange system and the signal converter.

The flange system contains the microwave window separating product from pressure, and the antenna system.

The compact signal converter contains the microwave generator and the entire signal processing system, including provision of a standardized output signal (4 - 20 mA or digital interface).

The signal converter can be separated from the flange system under process conditions, without loss of pressure or escape of product.

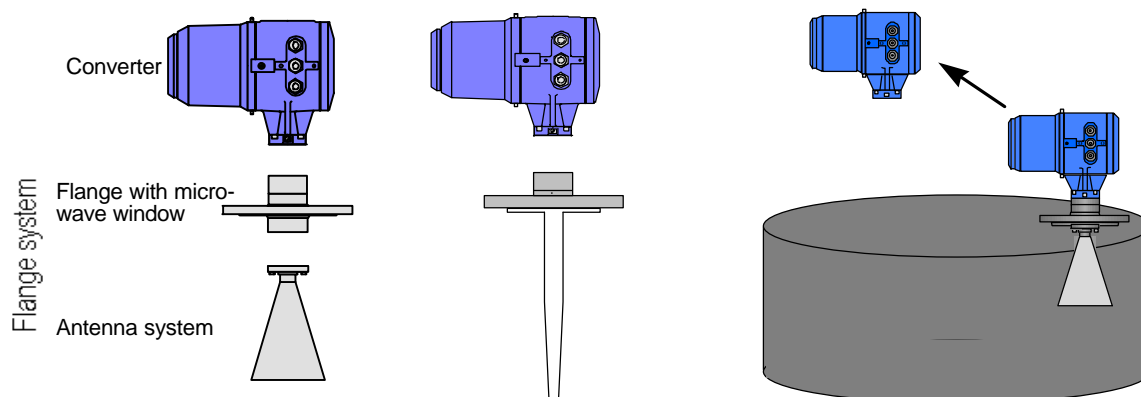

3 Input

3.1 Measured variable (distance, level, volume, reflection)

The primary measured variable is the distance between a reference point (as standard: tank mounting flange) and a reflecting surface (e.g. surface of the liquid).

The filling level is determined by allowing arithmetically for the entered tank height.

Volume measurements are possible by entering a conversion table (max. 50 points).

The strength of the reflected signal can be measured for qualitative assessment of the tank product or its surface.

3.2 Measuring range [0.5-35/40 m (1.64-115/131 ft)]

Minimum tank height		0.5 m (1.64 ft)
Maximum measuring	BM 70 A	40 m (131 ft) / optionally 100 m (328 ft)
	BM 70 A mit Wave-Stick	20 m (65.62 ft)
	BM 70 P	35 m (115 ft)

The useful range will depend on the antenna size, the reflection properties of the tank product, the installation position, and the presence of interference reflectors (see Sections 6.1 and 7.5).

3.3 Block distance

The block distance is the minimum measured distance between the mounting flange (reference point) and surface of the tank product.

Recommended minimum values: see following sketches.

Horn antenna without stilling well:

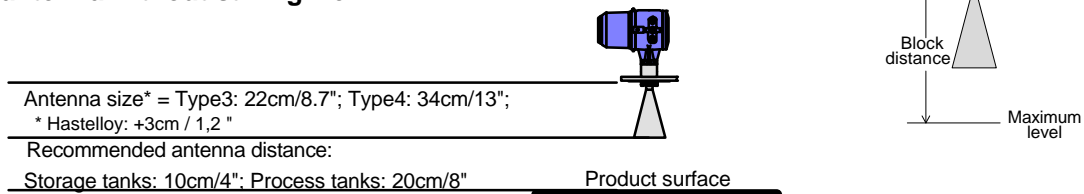

The length of any antenna extension used must be added on!

Stilling well / Wave-Guide

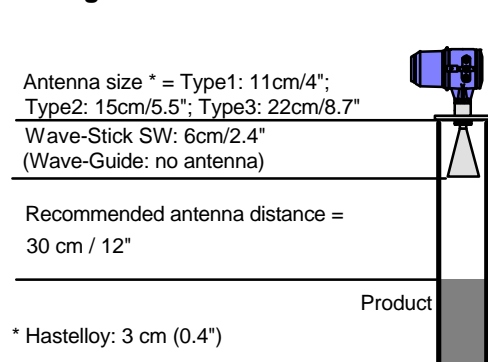

Wave-Stick

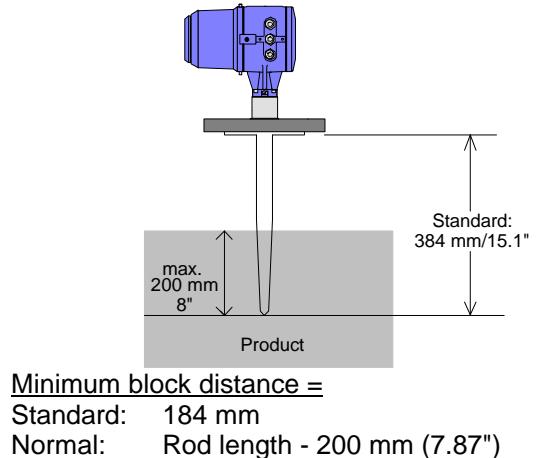

3.4 Out-of-range performance

When the level measuring range is exceeded (including flooding) the measured value will stick at the (adjustable) block distance (see Sect. 8.6.14).

If the measured value drops below the level range, it will stay put at the set lower range limit (distance = tank height).

4 Output

4.1 Variants

Variants	Remarks	Described in Section
Ex-e current output HART®	Ex-e; active; HART® protocol; together with switching output and digital input	4.2 + 4.4
Ex-i current output HART®	intrinsically safe; passive; HART® protocol (optionally with intrinsically safe switching output)	4.3 + 4.4
Current output	Ex-e; active; non-communicable	4.5
RS 485 + current output	BM70 protocol or ModBus-RTU or HART®	4.6 + 4.5
PROFIBUS-PA	intrinsically safe; see Supplementary Instructions	-
Foundation Fieldbus (FF)	intrinsically safe; see Supplementary Instructions	-

All versions with HART® or BM70 protocols can be operated with the PC-CAT PC program (see Section 8.12).

Overview of digital Communication possibilities:

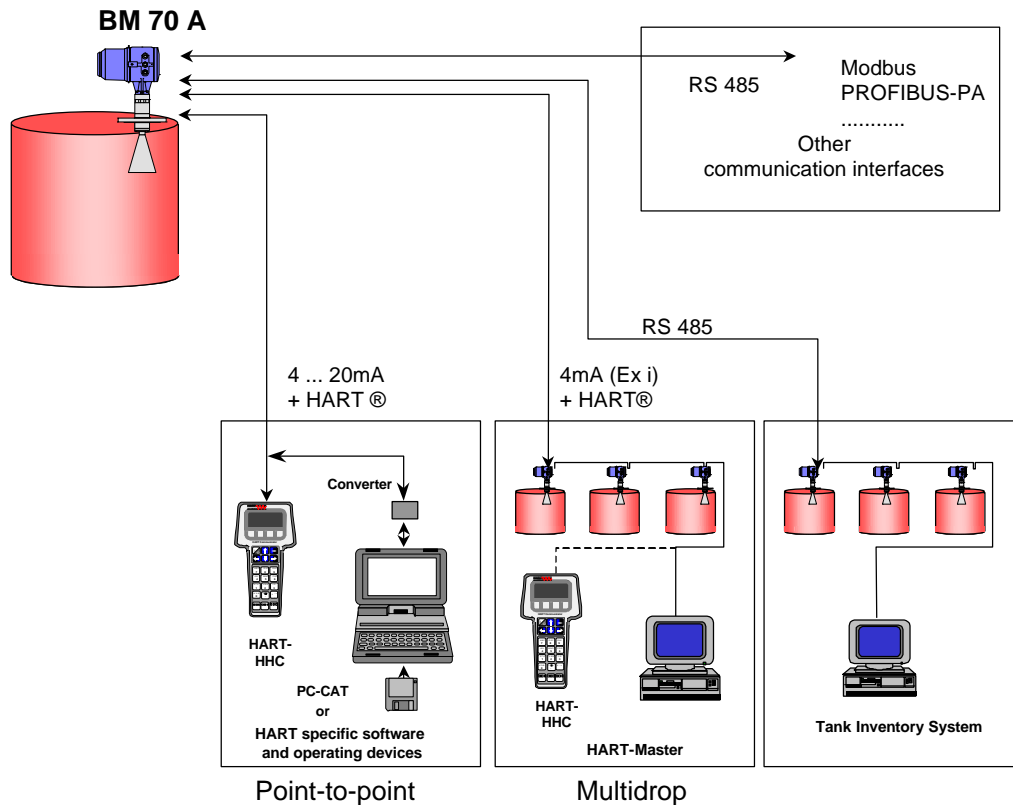

4.2 Ex-e current output HART®

Function	Level, distance, volume (conversion table) or reflection, and error identification; galvanically isolated from digital input and switching output
Current	4-20 mA; without or with error message (2 mA and 22 mA)
Accuracy/linearity	0.05 % (rel. 20 mA; at T = 20°C, 100Ω load impedance and nominal operating voltage)
Temperature drift	≤ 100 ppm/K (typically 30 ppm/K)
Load impedance	≤ 500 Ω
Effect of load impedance	≤ 0.02 % (rel. 20 mA for R _B = 0...500 Ω)
Effect of power	≤ 0.02 % (rel. 20 mA for U _B within limits of tolerance)
Hazardous-duty version:	Ex e

Note: together with switching output and digital input

Digital input (terminals 81/82):

Can be used to suspend the entire measurement procedure, i.e. measurements are "frozen" (standard setting), or to hot start the device (reprogramming by KROHNE Service).

Applicable voltage: 5...28 V DC

Input resistance: ≥ 1 kΩ

Switching output (terminals 41/42):

Can be programmed as a limit switch, alarm contact or error message.

The contact is open in the de-energized condition.

Operating data: max. 100 mA / 30 V DC or 30 V AC.

Internal resistance: ≤ 20 Ω

4.3 Ex-i current output HART® (type of protection: Ex de [ia])

Function	Level, distance, volume (conversion table) or reflection; and error identification; passive output (current sink)
Current	4-20 mA; without or with error message (3.6 mA / 22 mA); 4 mA constant, adjustable for HART®-Multidrop
Temperature drift	≤ 100 ppm/K (typically 30 ppm/K)
Accuracy/linearity	0.05 % (rel. 20 mA; at T = 20°C, 10 V supply voltage and nominal operating voltage)
Supply voltage U	8-30 V (between terminals 31 and 32)
Load impedance	≤ (U _S - 8V) / 22 mA (U _S = external supply voltage)
Effect of supply voltage	≤ 0.02 % (rel. 20 mA for U = 8...30 V)
Effect of power	≤ 0.02 % (rel. 20 mA for U _B within limits of tolerance)
Note:	Digital input not available.

Optional switching output (terminals 41/42):

can be programmed as limit switch, alarm contact or error message.

The contact is open in the de-energized condition.

Operating data: 6...30 V; I_{Low} ≤ 110 mA; U_{Low} ≤ 2V; I_{High} ≤ 900 μA (U=30V) and I_{High} = 200 μA (U=8V)

Ex-i safety limits

Signal circuit in type of protection: Intrinsic Safety EEx ia IIC/IIB or EEx ib IIC/IIB for connection to a certified intrinsically safe circuit with the following peak values:

U₀ = 30 V; I_k = 250 mA

Effective inner capacitance ≈ 0; effective inner inductance ≈ 0

4.4 HART® communication

The HART® Communications protocol can, in accordance with the Rosemount Standard, be used with a BM 70 A/P.

Electrical connection: see Section 7.8.

There are two ways of using the HART® Communication:

- a) As a **point-to-point** connection between the BM 70 A/P and the HART® master equipment.
A BM 70 A/P can be used either with an Ex-e current output HART® or with an Ex-i current output HART®.

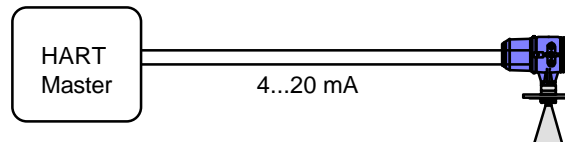

- b) As a **multipoint connection (multidrop)** with up to 15 devices (BM 70, BM 70 A/P or other HART® equipment), in parallel on a 2-wire **bus**:
A BM70 A/P is normally used with Ex-i current output, but an Ex-e current output can also be used (constant 4 mA in both cases.)

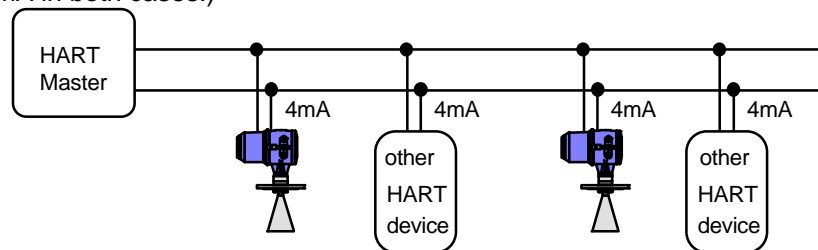

4.5 Current output (non-communicable)

Function	Level, distance, volume (conversion table) or reflection, and error identification
Current	4-20 mA; without or with error message (2 mA and 22 mA)
Accuracy/linearity	0.3 % (rel. 20 mA; at T = 20°C, 100 Ω load impedance and nominal operating voltage)
Temperature drift	≤ 200 ppm/K (typically 70 ppm/K)
Load impedance	≤ 250 Ω
Effect of load impedance	≤ 0.1 % (rel. 20 mA for R _B = 0...250 Ω)
Effect of power	≤ 0.1 % (rel. 20 mA for U _B within limits of tolerance)
Hazardous-duty version:	Ex e

When operated as a switching output (digital output):

Function	limit switch, alarm contact or error message
Low status	current < 2 mA
High status	current = 22 mA (when load ≤ 250 Ω)
No-load voltage	≤ 18 V

4.6 Digital interface RS 485

RS 485 is a bus that allows two-way Communication (half-duplex operation) with the BM 70 A/P Level-Radar. When the computer system sends out a request, the BM 70 A/P transmits: level, distance; volume (conversion table), reflection, setting parameters and status.

A PC can configure any BM 70 A/P via the bus (RS 485/RS232 converter required) by means of the PC-CAT program, provided no master is active. The maximum cable length - excluding amplifier - is 2000 m.

Transmission rate: 1200 to 38400 bauds
 Address: 0 to 255
 Protocols: KROHNE Protocol, HART®, Modbus RTU (from firmware V.3.02/4.02)
 Additional information: see "BM 70 A/P Communication RS 485" instructions
 Additional current output: The current output is conductively coupled to the RS 485 interface. Technical data: see Section 4.5
 Note: Switching contact and digital input are not available. However, the current output can be configured as a switching output.

Various bus configurations

A) Connection of a BM 70 A/P as a single RS 485 user:

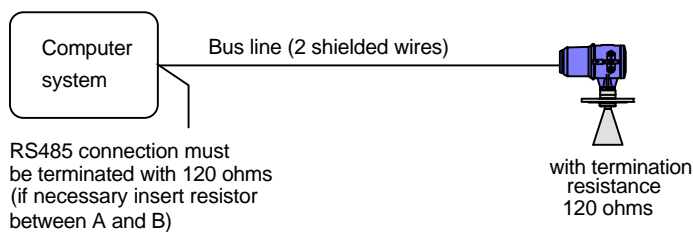

B) Connection of several BM 70 A/P in the RS 485 bus system via stubs to the bus cable:

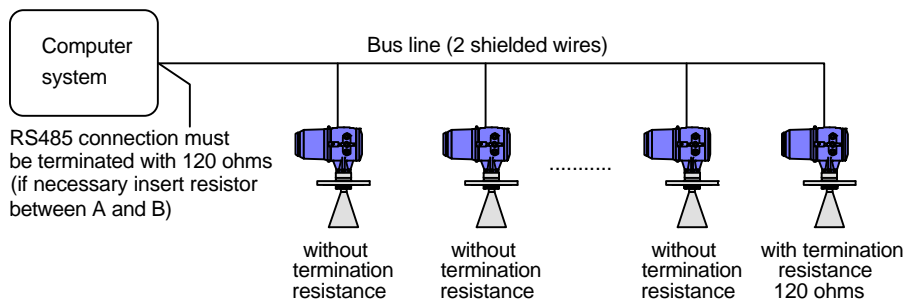

C) Connection of several BM 70 A/P in the RS 485 bus system, with bus cable looped through to further field instruments:

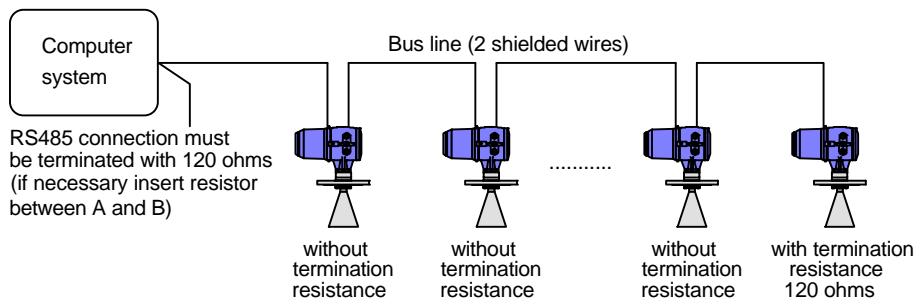

Notes:

- If other devices are operated together with the BM 70 A/P Level-Radar on one bus, all devices must use the same Communications protocol (e.g. ModBus devices of different makes or BM 70 A/P and TTM 70 with KROHNE Protocol).
- When "HART®" is set as the protocol type, use only the protocol in keeping with the "HART® Specification". The "Hardware Implementation RS 485" does not conform to the HART® Standard (see Sections 4.2 and 4.3).

- Since signal reflections at the line ends can interfere with Communication, both the line beginning (at the computer system) and the line end (at the last device) should be terminated with the typical surge impedance of the cable (120 Ω). To do this inside the BM 70 A/P: see Section 7.9.

4.7 Breakdown signal

Breakdown information can be called up via the following interfaces:

- Local display: flashing display, plain text information
- Current output: error signal 2 mA ($E_{xi} = 3.6$ mA) or 22 mA
- Switching output: contact opens or closes
- Digital interfaces: interrogation of error flags

4.8 Digital input

The digital input (for electrical data: see Section 4.2) can be used for temporarily "freezing" measurements or for carrying out a hot start. It is only available in the "Ex-e current output HART[®]" version.

The "freeze" function can be used to blank out larger, temporary interferences, e.g. very slow agitator, slide gate, ball valve in the stilling well. The last measured values in each case are present at outputs I and S, and in the display. The digital input is also taken into account when the empty-tank spectrum is being recorded (totalizer does not continue). marker 6 in the display indicates that the digital input is active in the "freeze" function.

NOTE: The function of the digital input is set as standard to "freeze". To switch the function to "hot start" or to deactivate it completely, the setting will need to be changed in the Service menu of the BM 70 A/P

5 Measuring accuracy

5.1 Reference conditions

- Temperature = +20°C / +68°F
- Pressure = 1013 mbar abs. / 14.5 psia
- Air humidity = 65%
- Highly reflecting product (e.g. water) with calm surface
- Tank diameter > 5 m / 16.4 ft
- Mounted at least 1/7 x tank height away from tank edge (BM 70 P: 1/5 x tank height)
- No interference reflections inside the radiation lobe ($\pm 6...9^\circ$; see Section 6.1.1)

5.2 Error of measurement

Since the measuring process primarily determines distance, measuring accuracy can only be specified as a function of the distance. For that reason, all figures given in this Section 5 refer to the measured distance.

BM 70 A: With antenna type 3 (139 mm / 5.47") or type 4 (200 mm / 7.87") or stilling well or Wave-Guide

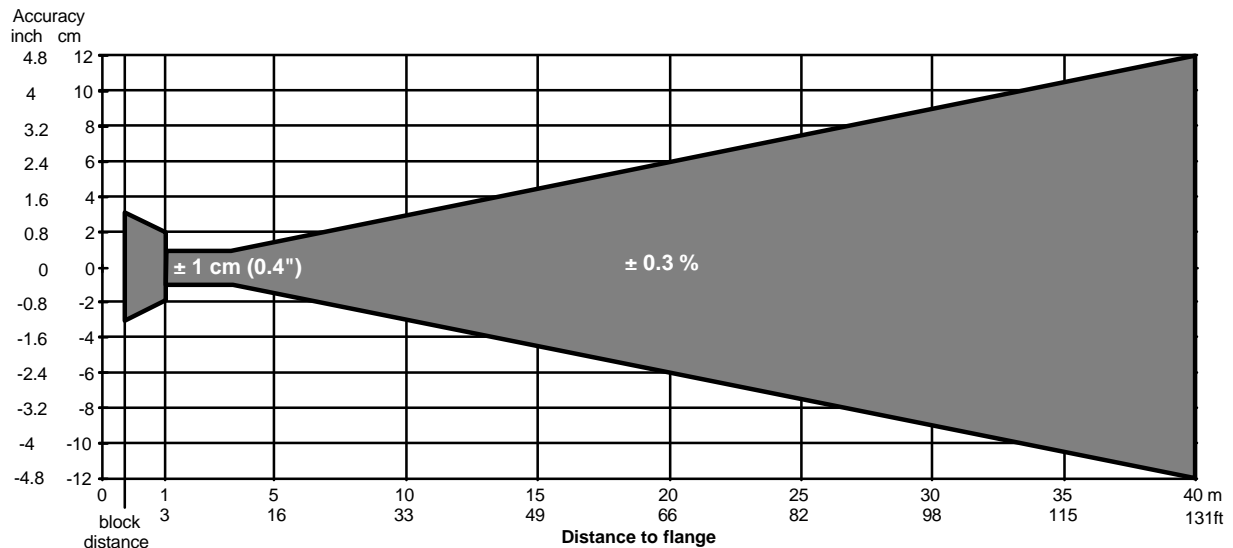

BM 70 A Wave-Stick:

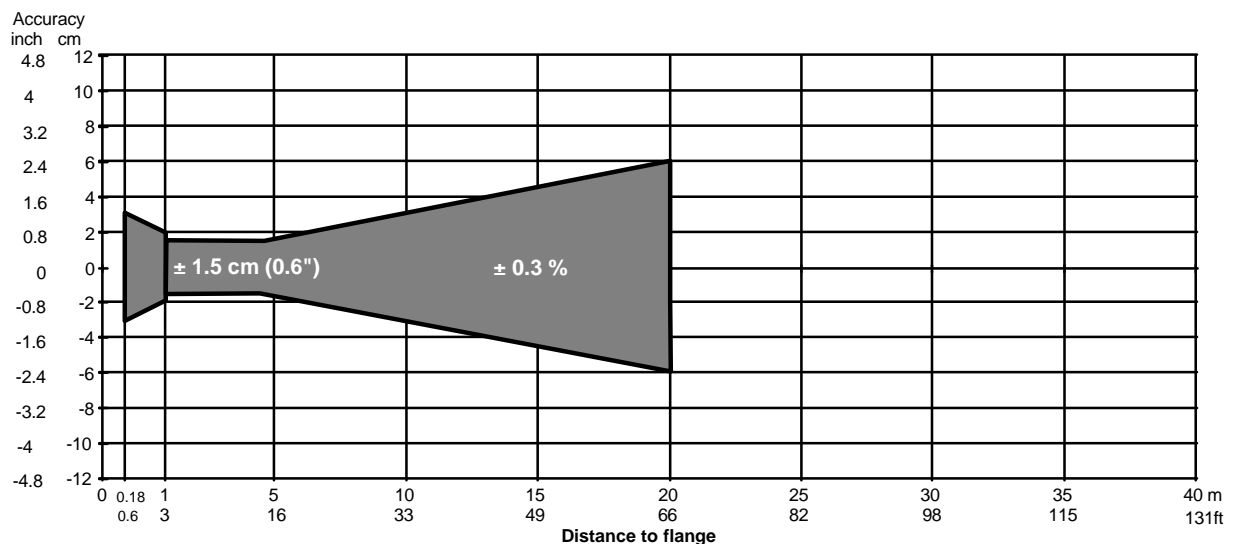

BM 70 A Precision (with special calibration and certificate):

Only with antenna type 4 (200 mm / 7.87") or stilling well 80 - 200 mm dia. (3 - 8")

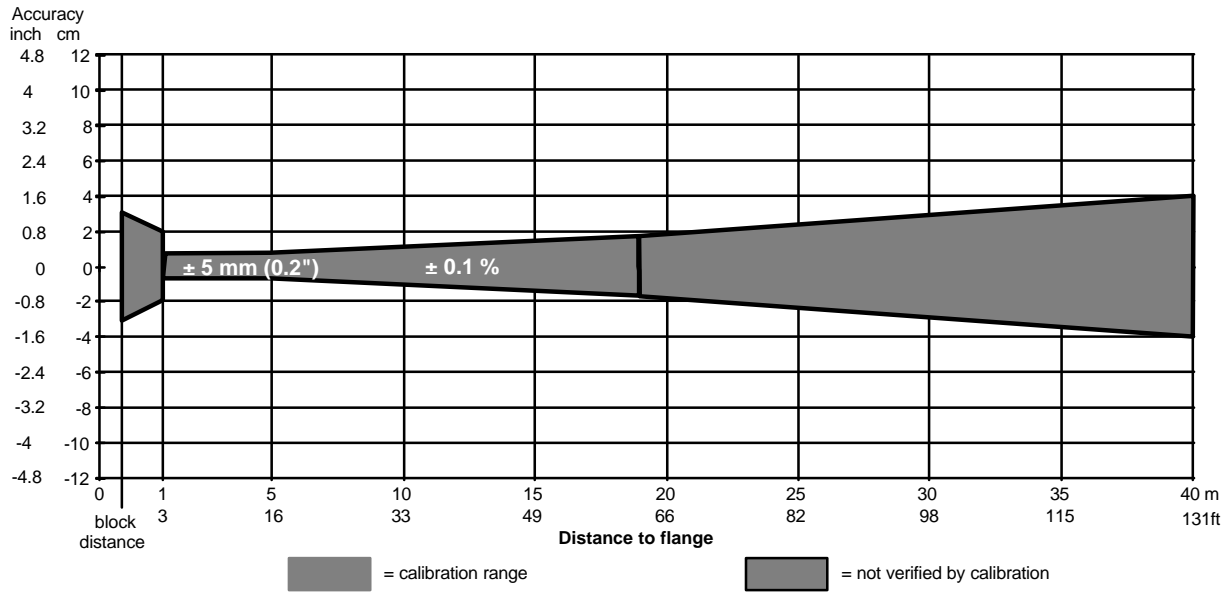

BM 70 P

Only with antenna type 4 (200 mm / 7.87") or stilling well 100 - 200 mm dia. (4 - 8")

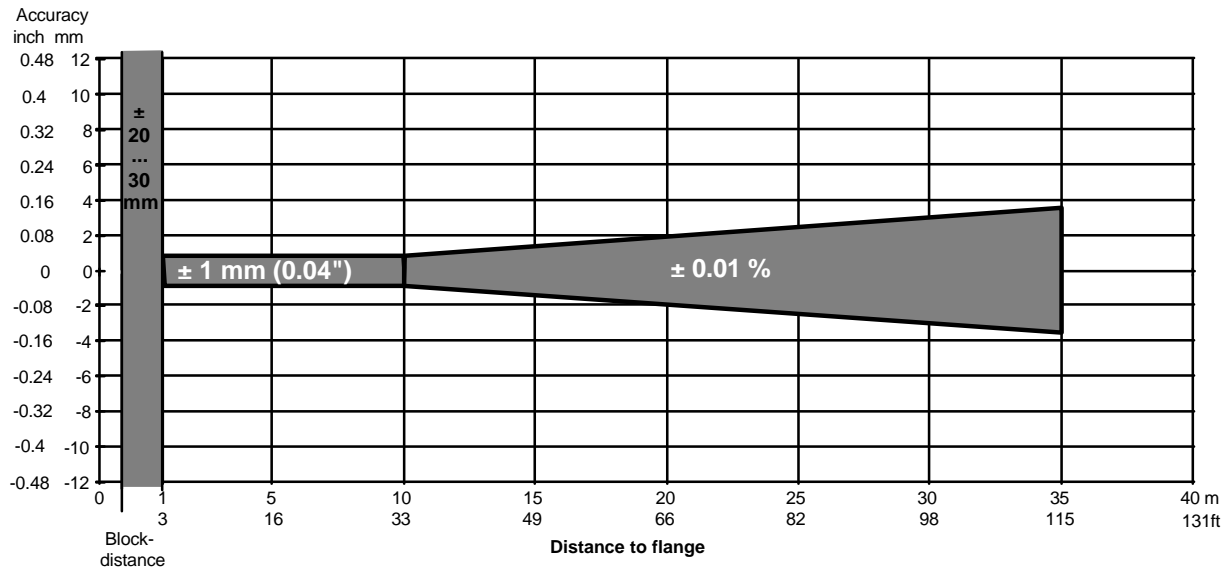

5.3 Repeatability

Repeatability is equal to half the value for the error of measurement.

5.4 Measured value resolution/hysteresis

Measured value resolution is: 1 mm / 0.04" for BM 70 A, and 0.1 mm / 0.004" for BM 70 P

Hysteresis is at least 20 times less than the error of measurement.

5.5 Transient recovery time

The transient recovery time is determined by the setting parameter "time constant" (1 ... 100 s).

The transient recovery time relative to 1% deviation from the steady-state value is approx. 4.6 times the time constant.

However, in the case of unusually rapid changes in level, the transient recovery time may deviate from this figure.

5.6 Turn-on drift / turn-on characteristics

A rough measured value is initially displayed about 1 minute after the BM 70 A has been switched on. The first self-calibration is completed after about 2 minutes. Full measuring accuracy is attained after 30 minutes operating time.

The measured value from the BM 70 P is accurate directly after the startup phase (approx. 1.5 minutes).

Typical turn-on drift (example):

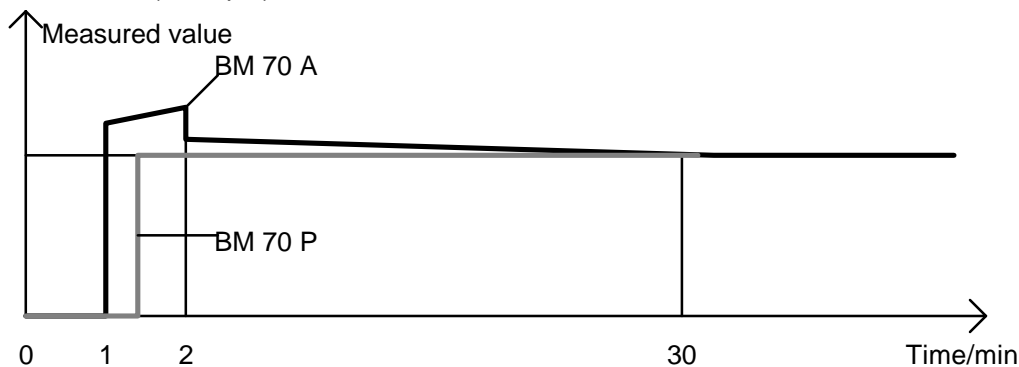

5.7 Long-term drift

The long-term drift is within the specified error of measurement.

5.8 Effect of ambient temperature

Temperature coefficient, signal output:

Ex-e current output HART®:	< 100 ppm/°C (typically: 30 ppm/°C)
Ex-i current output HART®:	< 100 ppm/°C (typically: 30 ppm/°C)
Current output:	< 200 ppm/°C (typically: 70 ppm/°C)
Digital interfaces:	no temperature effect

The temperature has no effect on the measured value as the device carries out a regular self-calibration.

The effect of temperature of the atmosphere above the liquid product results theoretically in -1ppm/°C for air.

In respect of proof of temperature effect with the aid of reference measurements in liquid tanks, it needs to be borne in mind that liquids generally have a high coefficient of cubic expansion (organic liquids: typically 0.15 %/°C)!

6 Operating conditions

Hazardous-duty systems

- The BM 70 A/P is certified in conformity with **European Standard** (ATEX) for use in Zone 0, 1 and 2 hazardous locations.
- The BM 70 A/P also has **FM Approval** (Factory Mutual) for CLASS I, DIV 1, GROUPS B,C,D; CLASS II/III, DIV 1, GROUPS E,F,G.
- Attention is drawn to the information given on the **nameplate** and the specifications in the **approval certificates**.
- When carrying out **installation, dismantling work** or making **electrical connections** in the hazardous area, be sure to observe the pertinent wiring and installation regulations, e.g. as specified in VDE 0165.
- Within the scope of routine checks required to be carried out on systems operated in hazardous areas (maintaining the system in good working order), the "flameproof enclosure" (large cover on signal converter) should also be **visually inspected** for signs of external damage and corrosion.
- Before **opening the "flameproof enclosure"** (e.g. to inspect the inside or for repair purposes) make absolutely certain in the hazardous location:
 - that the BM 70 A/P Level-Radar is disconnected from voltage, and then allow the prescribed waiting time of 22 minutes to elapse first,
 - and that there is no explosion hazard (gas-free certificate!).

Safety

- **Operator control via the keys:** on electrical safety grounds, operator control of the keys (below the display, with the housing open) may only be carried out by specialist personnel for service and repair work, **on no account, however, when there is risk of explosion!**
- **Surface temperature:** the housing of the signal converter can, in extreme ambient conditions, assume temperatures of more than 70°C (158°F)!

6.1 Installation conditions

Refer to Section 7.5 for selection of the optimum antenna type

6.1.1 Transmission angle

The transmission angle is defined as the angle α to the vertical, in which the power density of the radar waves assumes half the value of the maximum power density (half-power beamwidth):

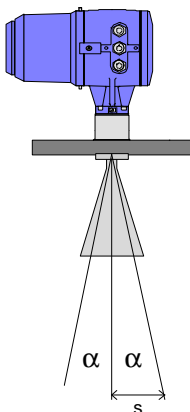

Antenna Type	Diameter mm (inches)	Transmission angle α	Lobe expansion s per metre distance
Type 4	200 (7.87)	6°	10 cm (3.94")
Type 3	140 (5.51)	8°	14 cm (5.51")
Type 2 *	100 (3.94)	12° *	22 cm (8.67")
Type 1 *	80 (3.15)	16° *	30 cm (11.8")
Wave-Stick	25 (0.98)	9°	16 cm (6.3")
Wave-Guide / stilling well	25-200 (0.98-7.87)	Propagation only inside the stilling well	

* Should only be used in stilling wells; the transmission angle given applies to line-of-sight propagation, i.e. without stilling well.

6.1.2 Recommendations for positioning on the tank

A) Horn antenna or Wave-Stick without stilling well

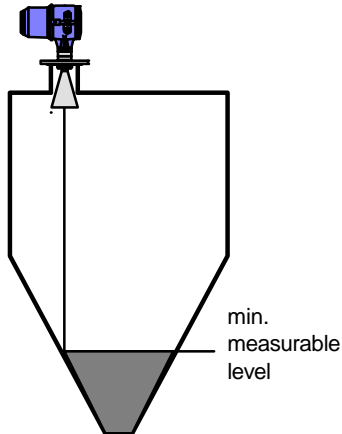
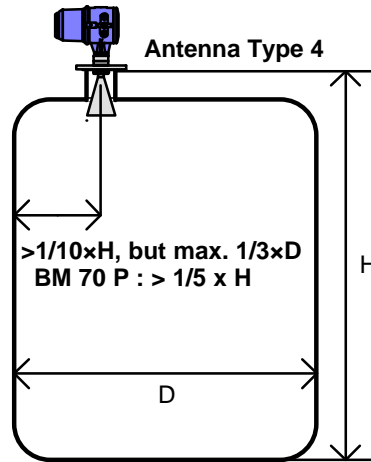
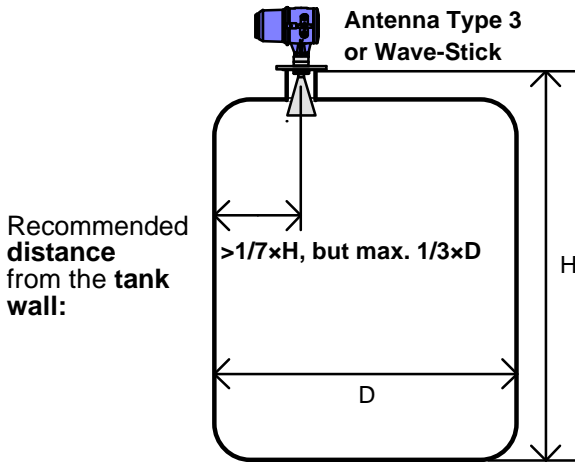

Lower measuring range limited when tank has tapered bottom.

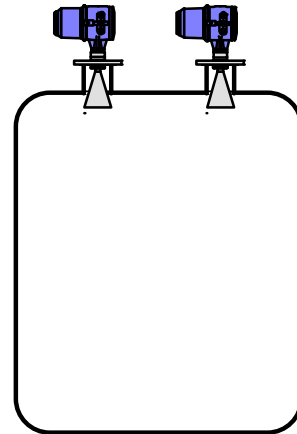

Several BM 70 A/P can be operated in one tank.

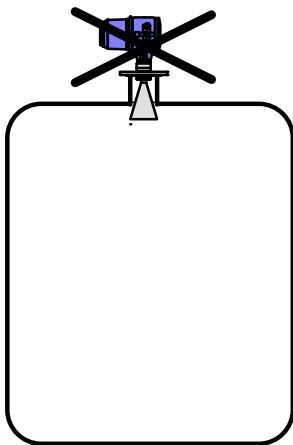

Do not position in tank **centreline!**
(multiple reflections!)

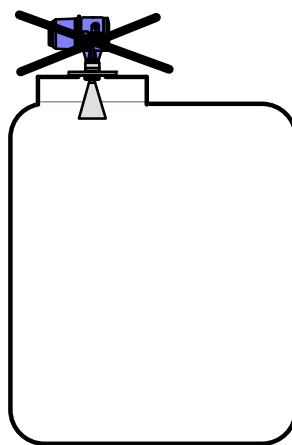

Do not mount **dead centre** on **manhole** cover!
(multiple reflections!)

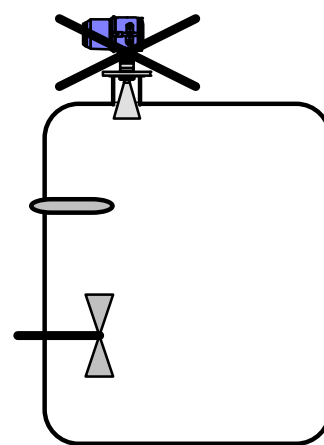

Do not position above **internals!**
(interference reflections!)

If these recommendations cannot be followed because of the tank geometry, please consult KROHNE.

B) Stilling well or Wave-Guide

A stilling well or Wave-Guide may be mounted in any position on the tank.
(For design layout: see also Section 6.1.4; for block distance: see Section 3.3).

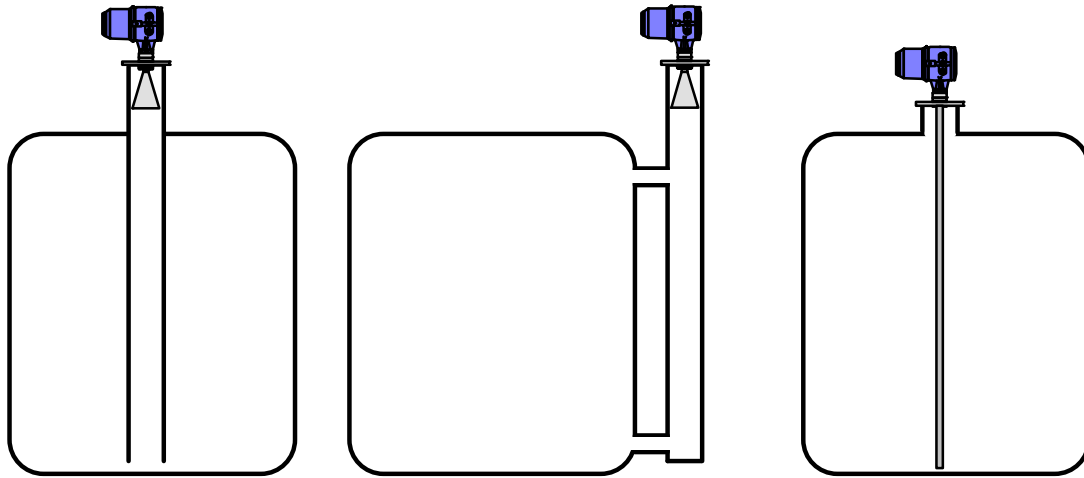

Stilling well application

In a side vessel

BM 70 A Wave-Guide

A stilling well or Wave-Guide is positively recommended for horizontal cylindrical tanks (to avoid multiple reflections):

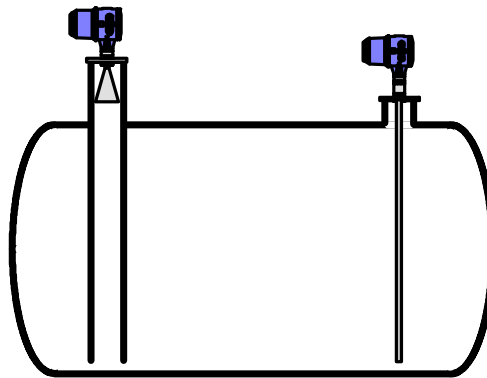

6.1.3 Mounting on tank fitting

A) Horn antenna

Should be mounted on the tank fitting as close to the horizontal as possible (deviation $\leq \pm 2^\circ$).

Exception: if product surface is not horizontal, (e.g. particulate materials) the flange can be aligned roughly parallel to it.

The antenna should project out of the fitting:

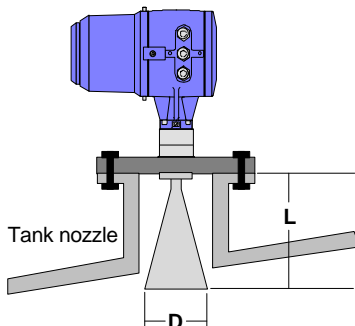

Antenna	Diameter D	Length l*
Type 4	200 mm (8")	335 mm (13.2")
Type 3	140 mm (5.5")	223 mm (8.8")

* Hastelloy: + 30 mm (1.2")

(subject to change without notice)

An antenna extension should be added if the antenna does not project out of the fitting:

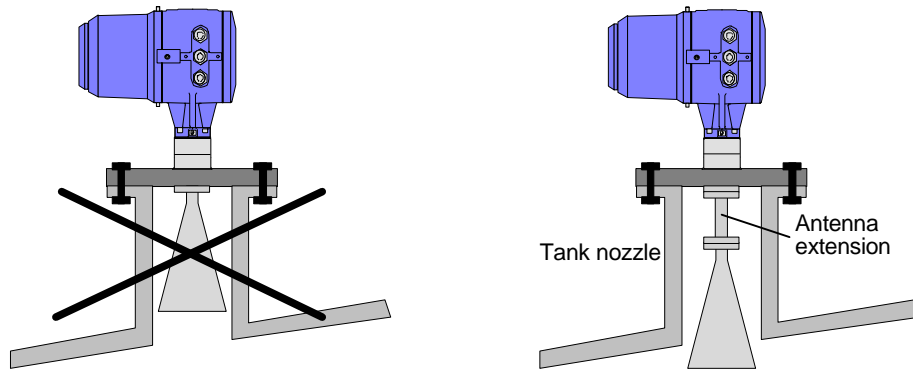

Antenna extensions are available from 100 to 2000 mm (3.94" to 78.74") in steps of 100 mm (3.94"). Several extensions can be joined up:

Exception:

When the tank fitting is symmetrical, the antenna may end in the fitting so as to enlarge the measuring range (minimum dead zone to tank cover, see Sect. 3.3 "block distance" and Sect. 5.2 "error of measurement"):

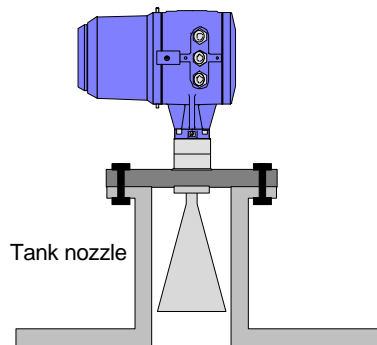

Narrow tank fitting

If the inside diameter of the fitting is smaller than the diameter of the antenna, and the fitting is accessible from inside the tank for mounting purposes, the antenna with extension can be mounted from the inside (not for versions made of titanium or tantalum). The antenna extension should be about 100 mm (3.94") longer than the height of the fitting.

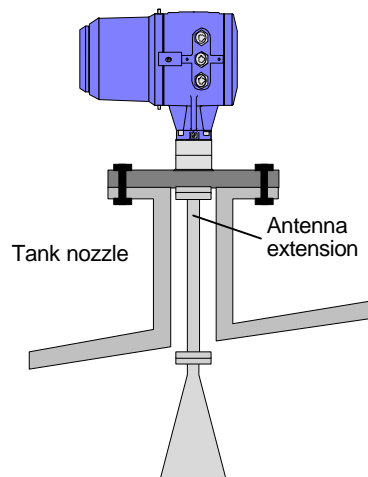

B) Wave-Stick

Note the requirements pertaining to diameter and length of the tank fitting:

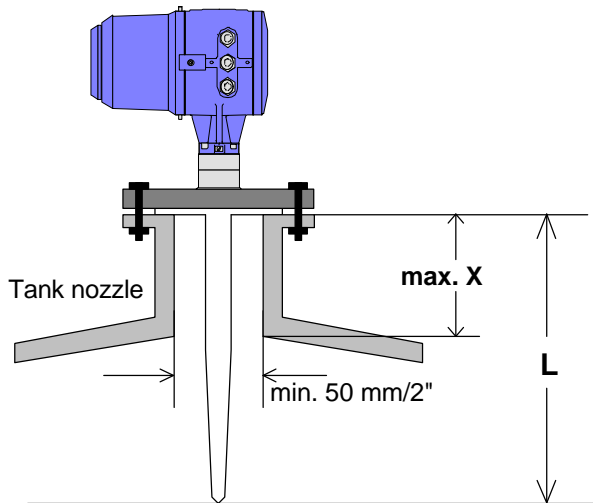

Version	Length L	max. height of fitting X
Standard	384 mm (15.12")	150 mm (15.12")
Option	500...1000 mm (19.7" - 39.4")	L - 234 mm (L - 9.2")

6.1.4 Mounting on stilling wells

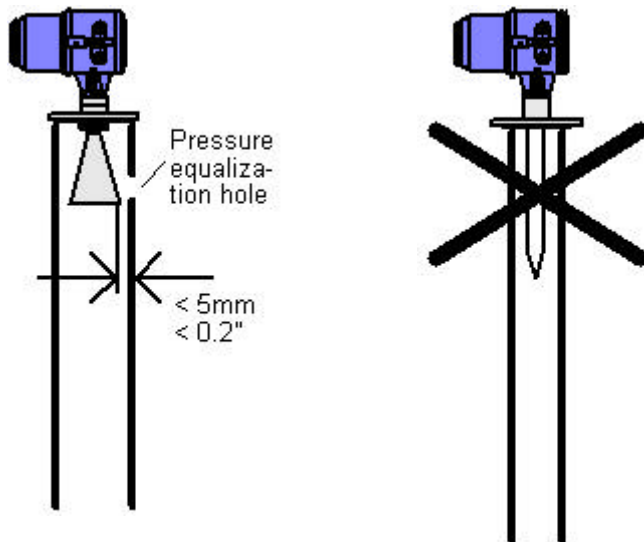

Antenna size must match inside diameter

A standard Wave-Stick will not function in a stilling well! For stilling wells 40-55 mm a type Wave-Stick SW can be used.

Antenna Type	Outside diameter
1	80 mm (3.15")
1s	76 mm (2.99")
2, 2s	100 mm (3.94")
3	140 mm (5.51")
3s	152 mm (5.98")
4, 4s	200 mm (7.87")

If necessary, turn antenna to size!

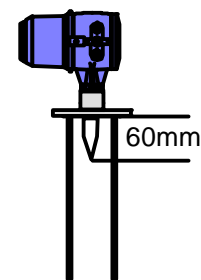

Further requirements concerning stilling wells:

- The well must be electrically conductive.
- Minimum inside diameter of well: 40 mm (1.57"). (BM 70 P: 80 mm, better ≥ 100 mm).
- If possible, use only smooth walled, straight stilling wells. If nevertheless an assembled stilling well is necessary, abrupt changes in diameter along the pipe should be less than 1 mm (0.04"). Surface roughness of the inside of the pipe should not be more than ± 0.1 mm (0.004").
- For the BM 70 P the antenna types 1s, 2s, 3s or 4s have to be used to achieve a high measuring accuracy.

It is possible to measure through a full-bore open ball valve if the valve and the pipe adapters above and below the valve are relatively smooth-walled.

- It is not possible to measure levels below the end of the stilling well.
- To ensure equalization of pressure, drill one or two small holes in the stilling well above the maximum filling level.
- If necessary, several holes can be drilled along the whole length of the pipe. All holes must be deburred. The holes should be as small as possible and spaced wide apart (Recommendation: see drawing on the right).
- It is advisable to fit a reference point at the end of the stilling well in the form of a rod or screw of approx. 6 mm (0.24") diameter. See drawing below.

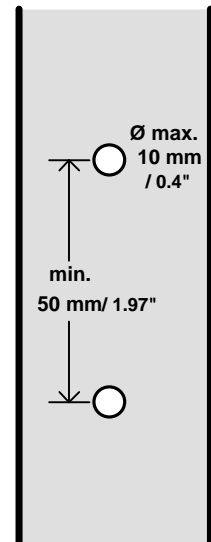
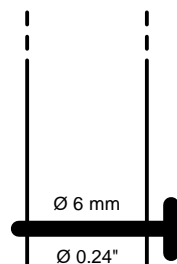

6.1.5 Wave-Guide

The "Wave-Guide" is a pipe with an outside diameter of 30 mm (1.18") and an inside diameter of 25 mm (0.98"), that is bolted direct to the BM 70 A flange system (in the same way as an antenna extension). It functions like a stilling well and can be used for clean products. The Wave-Guide is not practical in conjunction with the BM 70 P as it will not provide high measuring accuracy.

maximum length:

Ex: max. 3 m (9.84 ft) (except tantalum: max. 1 m (3.28 ft)).

Non-Ex: up to 3 m (9.84 ft) without additional support

Pipes longer than 3 m (9.84 ft) need to be fixed at two points.

6.1.6 Curved antenna extensions

Rectangular and S-shaped extensions are available for particularly difficult operating conditions. Such extensions can be used in cases where the antenna is exposed to especially high temperatures and where there are problems of space, (e.g. to avoid internals; positioning the antenna away from the centre of symmetry; lateral mounting of the signal converter).

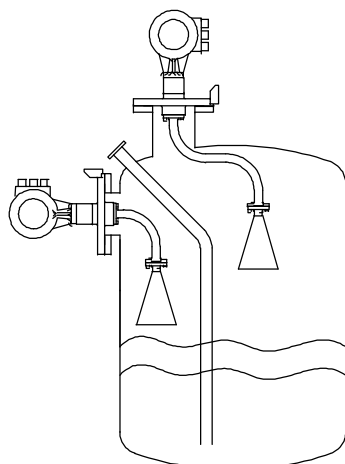

Standard sizes (others on request):

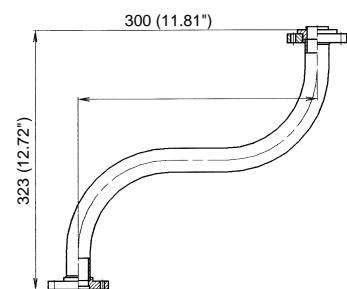
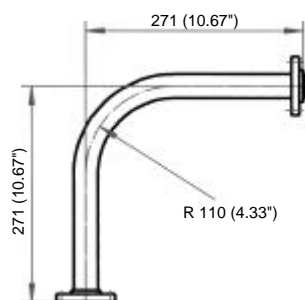

Dimensions in mm (inches)

6.1.7 Special options for the flange

Antenna heating/cooling device (\geq DN150/6")

Double-walled antenna for cooling or heating, e.g. to avoid condensation (recommended for liquid sulphur).

max. differential pressure at antenna:

Standard DN150

= 6 bar (87 psig) (information on other pressure levels provided on request)

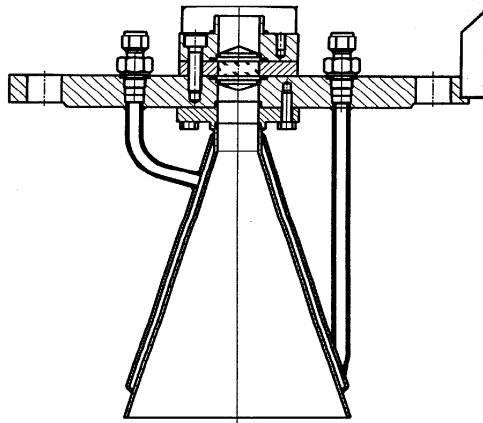

Purging device (\geq DN100)

With connection for purging the inside surface of the antenna to prevent heavy deposits of product or to heat or cool the antenna.

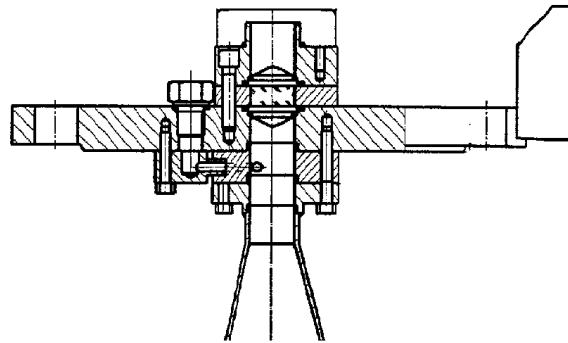

Hazardous-duty systems:

1. In Zone 0, the temperature of the heating system and antenna may not exceed 80 % of the ignition temperature of the stored material.
2. Continuous monitoring shall ensure, and operational inspections shall verify, that the 80% level of the ignition temperature stated in Point 1 above is not exceeded.

If a liquid is used for purging, this may interfere with the functioning of the BM 70 A/P during the process. Continuous purging with gas is not a problem as it does not interfere with measurements.

The purge connection is closed off by the manufacturers with a 1/4" screw. When this screw is removed to connect up a purging system, the operator is responsible for ensuring conformity with "Ex" requirements in connection with the purging circuit (e.g. fitting a flame trap).

6.1.8 Ultimate installation on the tank

- After carefully positioning the BM 70 A/P on the tank fitting flange (not forgetting the gasket), align the BM 70 A/P and the gasket.
 - Insert stud bolts and tighten nuts slightly (by hand). (These items not included with supply).
 - Press **shielding strip C*** in the gap between tank flange and the BM 70 A/P flange and secure with **strap retainer S*** (both items included with supply).
 - **Strap retainer S*** must fit closely and overlap both flanges.
- * only required for European radio approvals
- Tighten down stud bolts and nuts firmly. The torque is dependent on the strength properties of the stud bolts and the pressure rating of the tank.

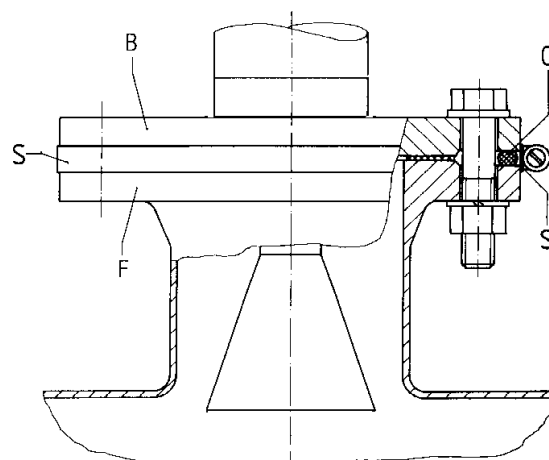

C* = shielding strip B = BM 70 A/P flange
S* = strap retainer F = tank flange

6.1.9 Sunshade

A sunshade **SD** is recommended to protect the signal converter from the effects of direct sunshine from above. This will increase the overall installation height by approx. 20 mm.

The sunshade is easily fitted/dismantled with the aid of 4 screws **S** (included). An Allen key (size 4 mm) is required.

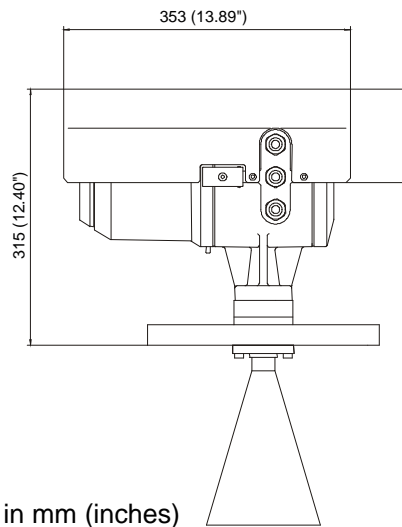

6.2 Ambient conditions

6.2.1 Hazardous locations

BM 70 A/P Ex is suitable for use in hazardous locations of the following zones: 0, 1, 2

Temperature classes: T6...T2; danger groups: IIA...IIC

For further information: see Section 10.

6.2.2 Ambient temperature of signal converter

BM 70 A/P with horn antenna or Wave-Guide: -20 ... +55°C (-4 ... +131°F)

A "BM 70 sunshade" should be fitted if the converter is located in the open with the likelihood of strong insolation (see Section 6.1.9).

6.2.3 Flange temperature

Horn antenna, Wave-Guide ($T_{amb}^* \leq 50^\circ\text{C}$): -30 ... +130°C (-22 ... +266°F)

Horn antenna, Wave-Guide ($T_{amb}^* \leq 55^\circ\text{C}$): -30 ... +120°C (-22 ... +248°F)

High-temperature version with distance piece and

FFKM gasket (Kalrez 4079 or Parofluor V3819-75): -30 ... +250°C ** (-22 ... +482°F)

Kalrez 2035 gasket: -30 ... +210°C (-22 ... +410°F)

Viton gasket: -30 ... +200°C (-22 ... +392°F)

FEP-sheathed gasket: -30 ... +200°C (-22 ... +392°F)

Wave-Stick, permanently: -20 ... +100°C (-4 ... +218°F)

Wave-Stick, pressure-dependent (see 6.3.5), with no mechanical loading radial to the rod: bis +150°C (302°F)

Wave-Stick, steam cleaning (CIP, SIP) for 30 minutes: max. +160°C (320°F)

* T_{amb} is the ambient temperature of the signal converter

** Safety limit: +280°C (536°F)

6.2.4 Ambient temperature limits

Signal converter:

Measuring function OK, but LCD "freezes up": min. -40°C (-40°F)

Functional upper limit, for max. 2 hours: max. +70°C (+158°F)

Flange system:

see Section 6.2.3

6.2.5 Storage temperature

-20 ... +60°C (-4 ... +140°F)

6.2.6 Environment class

Locations exposed direct to open-air climate, D1 Severity in conformity with EN 60654-1

6.2.7 Protection category

Signal converter: IP 66 / IP 67 (equivalent to NEMA 6)

6.2.8 Shock resistance

The device has been found to withstand the impact test in conformity with EN 61010, Section 8.2, with 0.5 J energy, and the drop test to prEN 50178:1994.

6.2.9 Vibration endurance limit

Type test conditions: to IEC 68-2-6 and prEN 50178 (10-57Hz: 0.075 mm / 57-150 Hz: 1 g)

6.2.10 EMC

The devices satisfy the requirements of EN 50081-1, EN 50082-2 and the NAMUR Recommendation.

6.3 Product conditions

6.3.1 Physical properties of the products

Physical properties (such as density, viscosity, conductivity, relative permittivity, magnetic properties, etc.) have no effect on measurement results.

The relative permittivity is merely required to have a minimum value in order to ensure reliable measurements (see Section 6.3.2).

6.3.2 Relative permittivity ($\epsilon_r \geq 1.5$)

The (relative) permittivity of the product (ϵ_r , Epsilon-R) determines the strength of the reflected signal. Measurement results are not affected so long as the reflected signal is strong enough, but reliability and the maximum measuring range are dependent upon the relative permittivity.

At $\epsilon_r < 3$, a stilling well should be used. The minimum relative permittivity of the product is approximately $\epsilon_r = 1.5$.

See also Section 7.5.

If the Wave-Stick is also to take measurements when immersed, ϵ_r will need to be ≥ 4 .

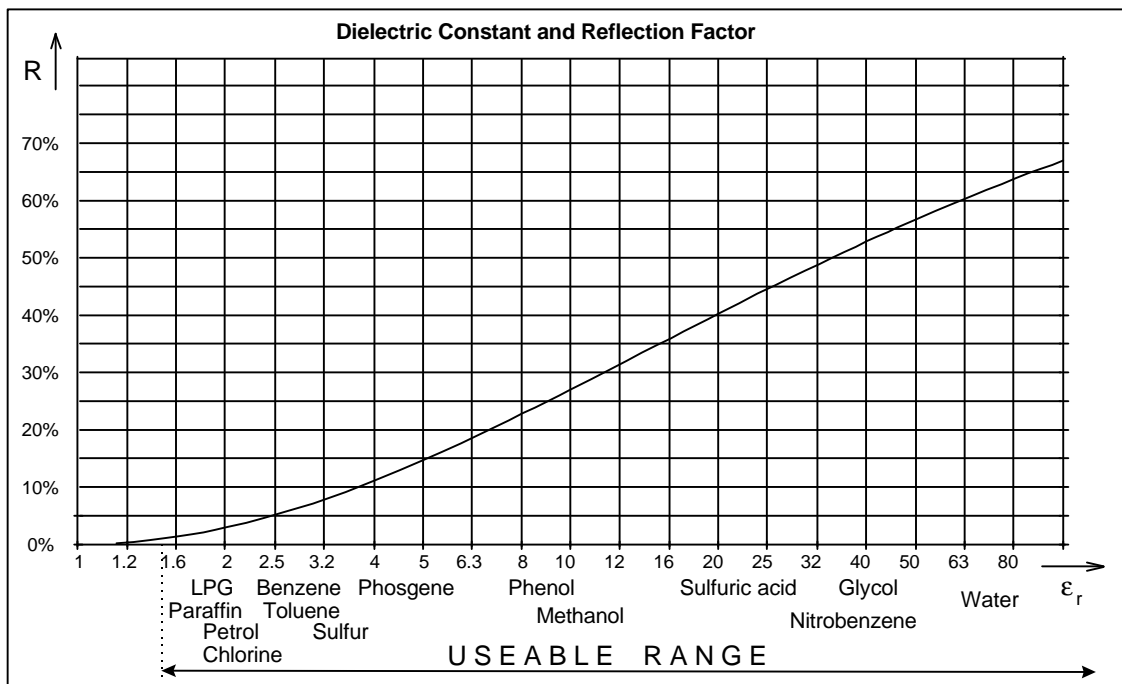

6.3.3 Product limitations

Radar-based level measuring devices are not suitable for the following products:

- liquid ammonia (NH₃)
- liquid hydrogen (H₂)
- liquid helium (He)

6.3.4 Product temperature (unrestricted)

The product temperature is not a relevant factor, provided the ambient temperature (see 6.2.2) and the flange temperature (see 6.2.3) are within the specified limits.

6.3.5 maximum allowable operating pressure (max. 64 bar / 928 psig)

Flange system with horn antenna or Wave-Guide:

	PN 16	PN 25	PN 40	PN 64
DN 80	16 bar (232 psig)	---	40 bar (580 psig)	64 bar (928 psig)
DN 100	16 bar (232 psig)	---	38 bar (551 psig)	55 bar (798 psig)
DN 150	16 bar (232 psig)	---	34 bar (493 psig)	47 bar (682 psig)
DN 200	16 bar (232 psig)	25 bar (363 psig)	32 bar (464 psig)	45 bar (653 psig)

Information on higher pressures (up to 400 bar / 5800 psig) supplied on request

Wave-Stick without plate resp. LP flange system: max. 2 bar / 29 psig

Wave-Stick with plate: max. 16 bar, dependent on temperature:

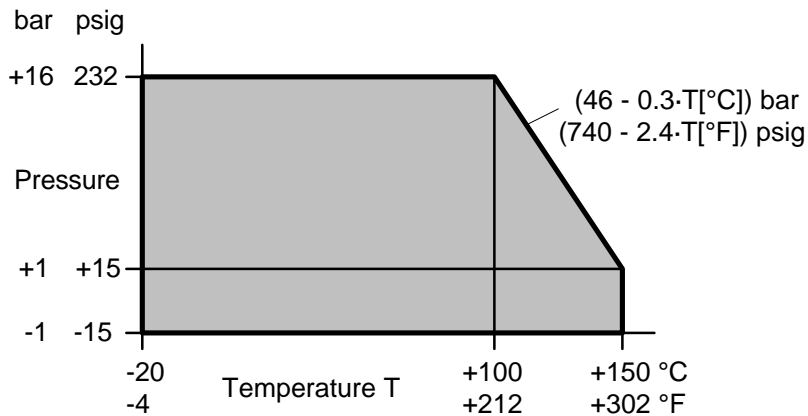

6.4 Maintenance

Cleaning the antenna

Particular process applications can cause severe contamination of the antenna. Microwaves cannot be properly emitted or received when reflected from deposits on the antenna. In such cases, the BM 70 A/P will usually indicate maximum level (volume) or minimum distance.

The level of contamination at which such errors occur depends firstly on the product concerned, and secondly on the reflection index, which is mainly determined by the relative permittivity ϵ_r .

Regular cleaning, or use of the purging device (see Sect. 6.1.7), is advisable if the product has a tendency to form deposits, etc.

When spraying, washing down, or cleaning with mechanical aids, take special care not to damage either the horn antenna or the bottom Teflon plug at the waveguide window (see Section 7.4 "Field assembly of the BM 70 A/P"). If cleaning agents are used, take material resistance into account!

7 Design

Hazardous-duty systems

The BM 70 A/P-Ex is approved to European Standard EN 50014/18/19/20 for use in hazardous locations of Zones 0, 1 and 2.

- **Electronics compartment:** Flameproof Enclosure "d"
- **Terminal compartment:**
 - Increased Safety "e" for signal output and power supply
 - Optionally: Intrinsic Safety "i" for the signal output and Increased Safety "e" for the power supply.
 - Special version: Flameproof Enclosure "d"
- **Pin coupler compartment:** Increased Safety "e"
- **Further details** are given in the Certificates of Conformity, see Section 10, and in the "**Hazardous-duty systems**" boxes (shaded grey in the text, e.g. at the beginning of Section 6), which should without fail be additionally heeded for the BM 70 A/P-Ex.

7.1 Models



BM 70 A/P with horn antenna



BM 70 A Wave-Guide



BM 70 A Wave-Stick

7.2 Dimensions and Weights

Basic version:

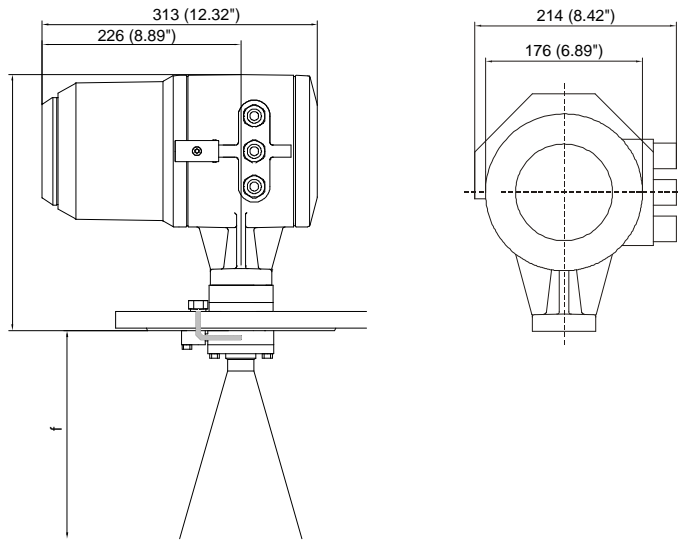

High-temperature version:

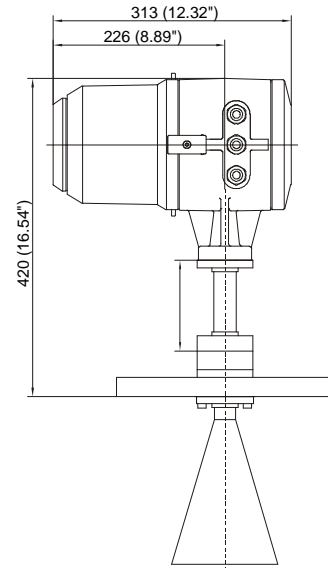

Meter size		Standard antenna			Length*		Weight	
DN (mm)	ANSI (")	Typ	ØA (mm)	ØA (")	f (mm)	f (")	kg	lb
80	3	1	80	3,15	110	4,33	17	37,48
100	4	2	100	3,94	148	5,83	18	39,68
150	6	3	140	5,51	223	8,78	23	50,71
200	8	4	200	7,87	335	13,19	30	66,14
80	3	1s	76	2,99	420	16,54	18	39,68
100	4	2s	100	3,94	620	24,41	19	41,89
150	6	3s	152	5,98	820	32,28	25	55,12
200	8	4s	200	7,87	820	32,28	32	70,55

* Hastelloy: + 30 mm (1.12")

Wave-Stick:

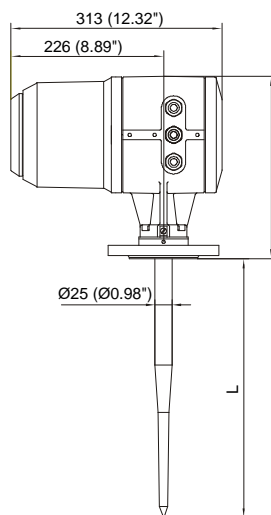

L = 384 mm Standard
500 – 1000 mm optional
60 mm Typ SW

Wave-Stick with hygienic connections:

(DIN 11851 "dairy") (with adapter for Tri-Clamp)

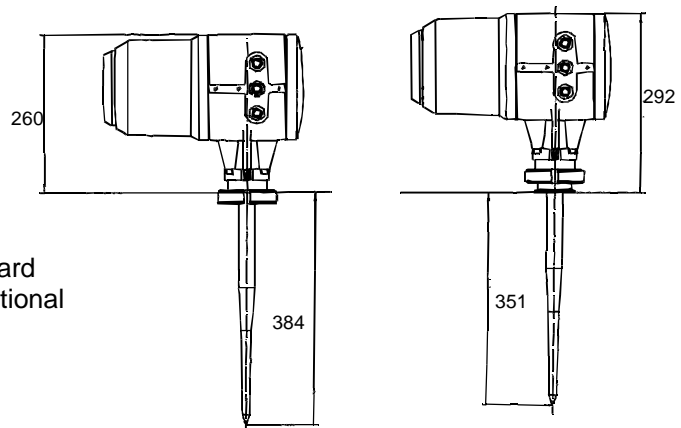

Flange size	dia. A in mm (inches)	Weight in kg (lb)
DN 50 / ANSI 2"	100 (3.94)	16 (35.27)
ANSI 3"	127 (5.0)	17 (37.5)
DN 80	138 (5.43)	17 (37.5)
DN 100 / ANSI 4"	158 (6.22)	18 (39.7)
DN 150 / ANSI 6"	216 (8.5)	23 (50.7)

Options:
Tri-Clamp 2", 3", 4"
SMS 51 mm, 63 mm, 76 mm
DIN 11851 (dairy)
DN 50, DN 65, DN 80

7.3 Replacement of the signal converter

Always disconnect from power source before commencing work!

Hazardous-duty systems

Before replacing the signal converter (instrument "head") in the hazardous location, make absolutely certain that there is no explosion hazard (gas-free certificate). Allow the prescribed waiting time of 22 minutes to elapse before opening the housing!

1. Remove safety lock (see Sect. 9.3) with machinist's wrench, size 4 mm, and unscrew cover from the terminal box with the special wrench. If a sunshade is fitted, remove this first (see Section 6.1.9).
2. Disconnect all cables from the terminals in the terminal compartment, see Section 7.8.
3. Remove the 4 Allen screws **M** (Allen key size 5 mm) and lift off the signal converter. The flange unit (incl. waveguide window) will remain tight, also on pressurized tanks.

Caution

On pressurized tanks, do not on any account remove the 4 screws **H** connecting the waveguide window to the BM 70 A/P flange! DANGER TO LIFE!

4. Install the new BM 70 A/P signal converter.
5. Check power voltage and fuse(s) (refer to instrument nameplate) and change or replace if necessary, see Sect. 9.2 and 9.3.
6. Reconnect all cables in the terminal compartment as described in Sect. 7.8.
7. Check against the attached report on settings whether the factory-set parameters are correct for your application. If not, reset the parameters as described in Sect. 8.
8. Subsequently, record the empty-tank spectrum, see Sect. 8.6.12.

Important:

Ensure that the screw thread of the covers on the terminal and electronic compartments is well greased at all times.

7.4 Field assembly

- When the BM 70 A/P needs to be field assembled, all required parts are included with the supply (stud bolts, washers, etc.).
- If supplied loose, bolt the waveguide window (flange assembly) or the distance piece to the BM 70 A/P. Tightening torque for the 4 Allen screws **M** (key size SW 5 mm): max. 8 Nm ~ 0,8 kpm.
- **Note:** The upper Teflon plug must be absolutely dry and clean! Moisture and dirt will negatively affect functionality of the BM 70 A/P!
- Bolt antenna and antenna extension together: torque for the 3 stud bolts: max. 8 Nm ~ 0.8 kpm.
- Do not on any account detach screws **H**!

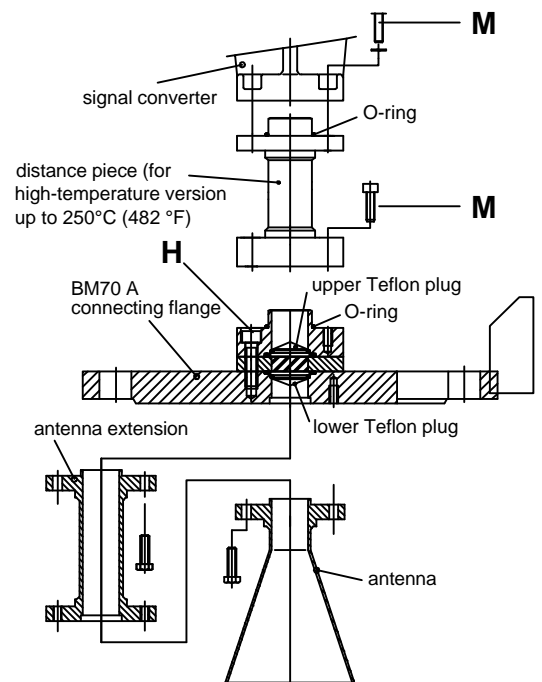

7.5 Selection of antenna type and size

This **BM 70 A recommendation** for the optimum application range is based on application experience and designed to minimize potential problems. If the recommended antenna is unacceptable, **any other configuration** may also be tested.

Type 1 and 2 antennas should only be used with stilling wells.

For **BM 70 P** always antenna type 4 or a stilling well > 100 mm / 4" is recommended.

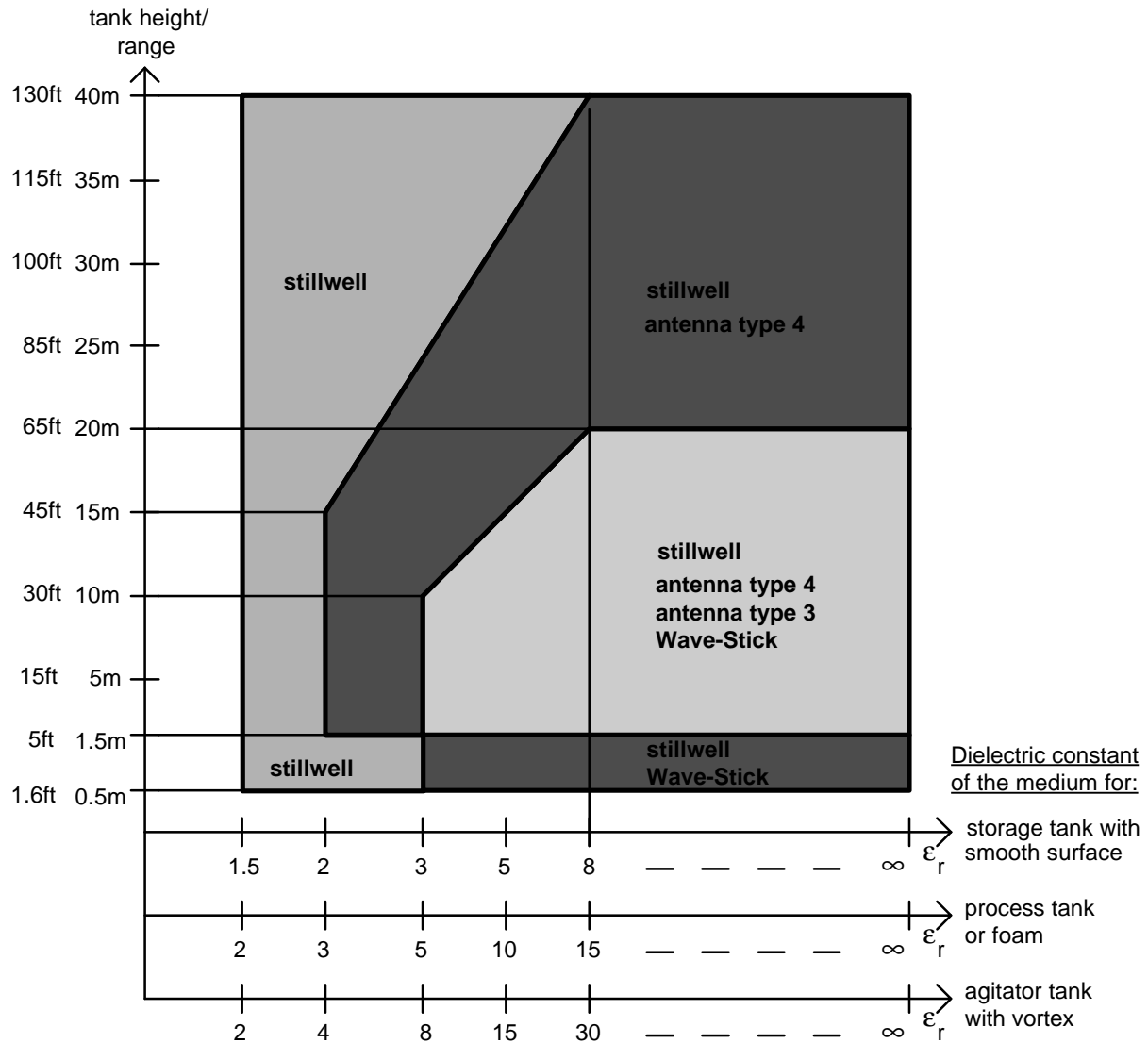

How to use the diagram:

- Determine the following application parameters:
 - a) Tank height or maximum measuring range/distance (e.g. H=15m)
 - b) Tank type (one of the three types shown, e.g. process tank)
 - c) Relative permittivity of the product (e.g. $\epsilon_r=5$)
- Find the relative permittivity on the relevant horizontal axis (e.g. 5 on the middle axis)
- Draw a line up to the required tank height = vertical axis (e.g. 15 m)
- The end of the line defines the application range. The text contained in that area indicates the suitable antenna types (in the example: stilling well or Type 4).

7.6 Materials of construction

Check the materials of the antenna, extension, flange, gaskets, and PTFE (contained in all versions) for compatibility with the product!

7.6.1 Signal converter

Housing: Aluminium with electrostatic powder coating to DIN 55990-3.

Sight window: Glass

7.6.2 Flange system

(Antenna, extensions and flange or flange plating)

Available materials for BM 70 A/P flange systems (in contact with the product):

	<i>DIN No.</i>	<i>AISI equivalent</i>
<u>Versions mit horn antenna or Wave-Guide:</u>		
Stainless steel	1.4571	316 Ti
Stainless steel	1.4435	316 L
Hastelloy C4	2.4610	-
Hastelloy B2	2.4617	-
Titanium	3.7035	-
Tantalum	-	-
Monell 400	2.4360	-
Inconell 600	2.4816	-

(Information on other materials supplied on request)

Wave-Stick:

In the versions with PTFE flange plate, only PTFE is in contact with the product (no metal in contact with the tank contents)

Flange made of stainless CrNi steel 1.4571 / 316 Ti

7.6.3 Seals and gaskets

Responsibility as to suitability rests solely with the user.

Available materials for internal device seals and gaskets in the flange system in contact with the product:

Material	Temperature resistance
FFKM (Kalrez 4079 or Parofluor V8545-75)	250°C/482°F (safety limit 280°C / 536°F)
DuPont Kalrez 2035	210°C/410°F
Viton (FPM)	200°C/392°F
FEP-coated	200°C/392°F

7.7 Process connection

The process connection is by way of standard flanges sized DN 50-200 or equivalent ANSI sizes (dependent on the version). Various hygienic connections are additionally available for the Wave-Stick (DIN 11851, Tri-Clamp, SMS).

Refer to Section 7.2 for further information on the various versions.

7.8 Electrical connection

The electrical connection for supply power and signal inputs/outputs is made in the terminal compartment (Ex-e) of the signal converter. Observe requirements specified in VDE 165, and consult the safety advice given in Section 9.4.

In the BM 70 A/P version with intrinsically safe signal output, only certified **intrinsically safe** equipment may be connected to the **blue** terminals, even if the device is not operated in the hazardous area!

- Terminals: conductor cross-section 0.5 - 2.5 mm² (solid conductor: max. 4 mm²)
- PE safety conductor and/or FE functional ground: U-clamp terminal (max. 4 mm² conductor cross-section) (see also terminal assignments below and in Sect. 9.4)
- Cable entries: 3x M25x1.5 (with standard cable gland: cable clamping area = 9-16 mm)
- Signal cable shielding: required for RS 485 line, recommended for current output when line lengths > 100 m (350 ft)
- "Ex" equipotential bonding: U-clamp terminal (max. 4 mm² conductor cross-section) on "neck" of signal converter

Rated temperature of power cables:

Version	Max. flange temperature	Rated temperature of power cables
w/o high temperature distance piece	≤ 100°C/212°F > 100°C/212°F	70°C/158°F 80°C/176°F
with high temperature distance piece	≤ 200°C/392°F > 200°C/392°F	70°C/158°F 80°C/176°F

Terminal assignment

Supply power:

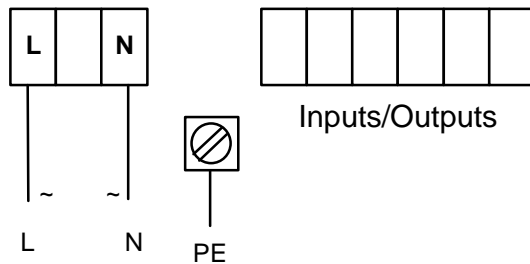

Connections for 115/230 V AC

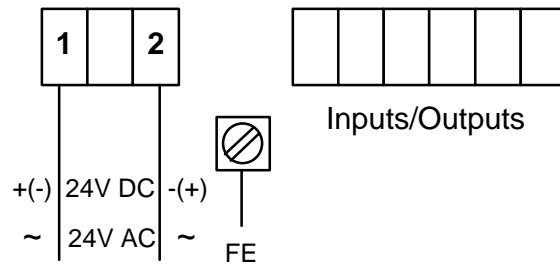

Connections for 24 V DC/AC (any polarity)
Connection of an FE functional ground is not mandatory.

Current output HART[®], Ex e:

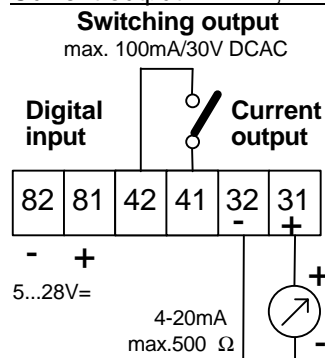

Ex-i current output HART[®]:

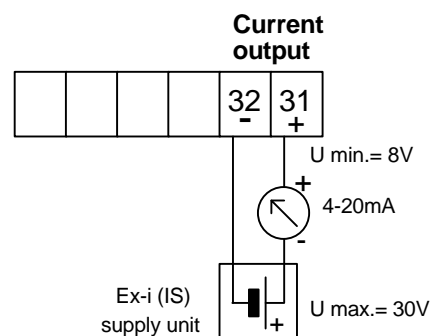

Ex-i Current output HART® with switching output:

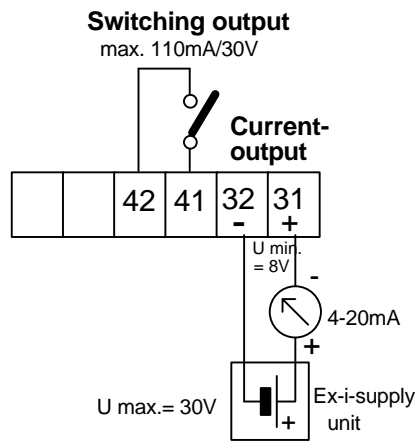

Current output (non-communicable):

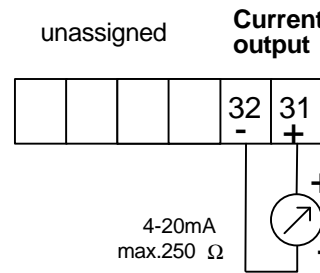

RS 485 version:

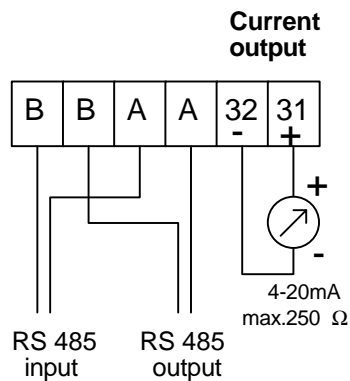

PROFIBUS-PA or Foundation Fieldbus (FF)

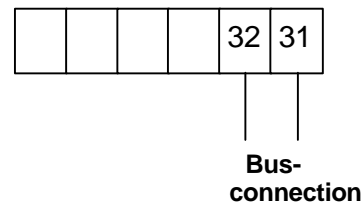

PROFIBUS-PA / FF with current output:

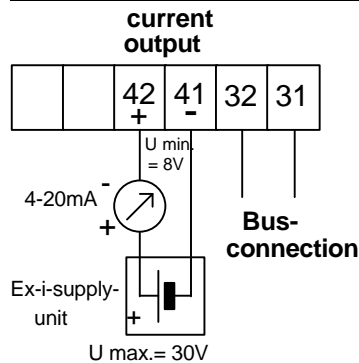

PROFIBUS-PA / FF with switching output:

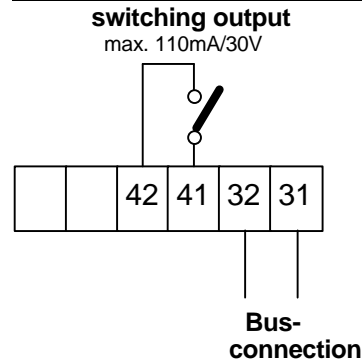

7.9 Terminating resistor for the RS 485 interface

A selector plug on the RS 485 board allows optionally a high-resistance termination (presetting) or a terminating resistor of 120 Ω at the RS 485 connections A and B. For this purpose, the housing (flameproof enclosure) of the BM 70 A/P signal converter needs to be opened (see Sect. 9.3) and the selector plug turned 180°, see sketch on the right.

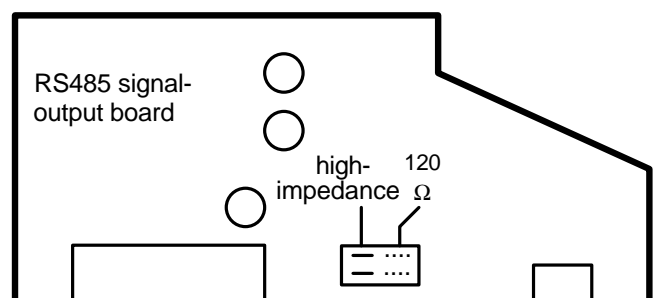

8 User interface

8.1 Local display

In the versions with local display at the BM 70 A/P signal converter, configuration can be carried out directly at the device. If a local display is not featured, the PC-CAT program (see Sect. 8.12) must be used to change the parameter setting (assuming a communicable interface is provided).

Two variants of the display are available:

- Standard display with 2-line LCD display (7 mm high digits for the measured value).
- Jumbo display with single-line LCD display and 16 mm high digits for the max. 5-digit measured value (restricted user friendliness for parameter setting, because 2nd line not visible).

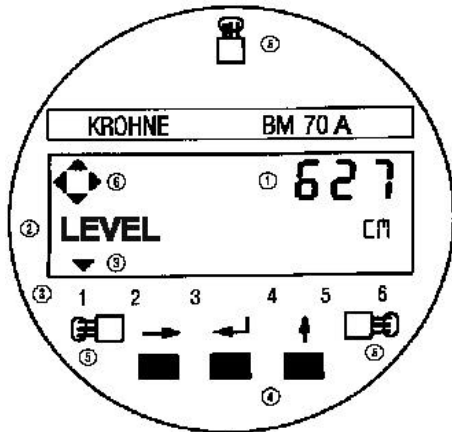

Standard display

- ① Numerical display of measured value
- ② Alphanumeric display of function/unit
- ③ 6 markers to indicate measuring status
- ④ 3 keys for configuration and error inquiry
- ⑤ magnetic sensors for control through the closed housing (function same as the 3 keys)
- ⑥ Compass field, signals actuation of a key

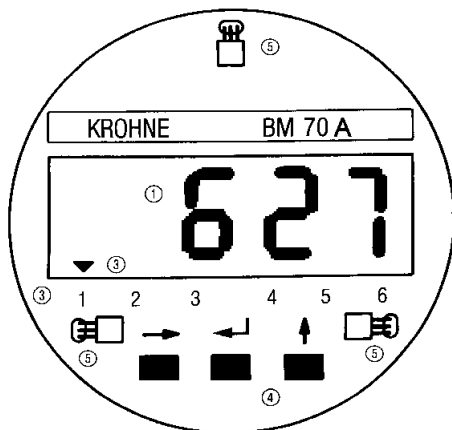

Jumbo display

- ① Numerical display of measured value (5 places)
- ③ 6 markers to indicate measuring status
- ④ 3 keys for configuration and error inquiry
- ⑤ magnetic sensors for control through the closed housing (function same as the 3 keys)

8.2 Function of the keys

The three keys have the following functions:

- (Cursor key):
 - selects the configuration menu,
 - branches the menu to the next lower level,
 - moves the cursor* to the right to the next column.
- ↑ (Select key):
 - branches the menu to the next digit in the same level,
 - changes the content (digit, character) at the cursor* position.
- ↵ (Enter key):
 - selects the error memory,
 - branches the menu to the next higher level,
 - stores newly entered parameters,
 - executes displayed functions.

* The cursor position is signalled by flashing of the character or selected point at the appropriate place.

To start operator control:

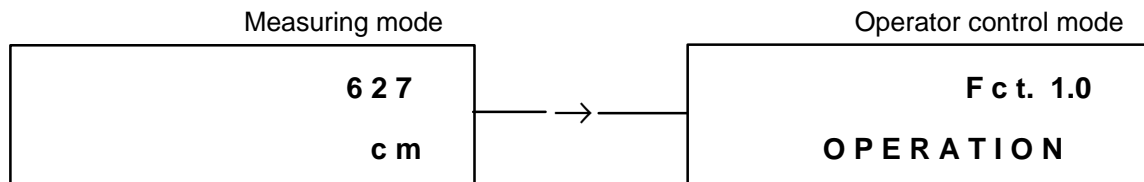

Please note: When "YES" is set under Fct. 3.4.2 and ENTRY CODE "CodE1 -----" appears in the display, the → key must be pressed.

The 9-keystroke Entry Code1 must then be entered:
 Factory setting: → → → ↵ ↵ ↵ ↑ ↑ ↑
 (each keystroke confirmed in the display by "*".)

To terminate operator control:

Press key ↵ repeatedly until one of the following menus is displayed.

Fct. 1.0 OPERATION, Fct. 2.0 TEST or Fct. 3.0 INSTALL.

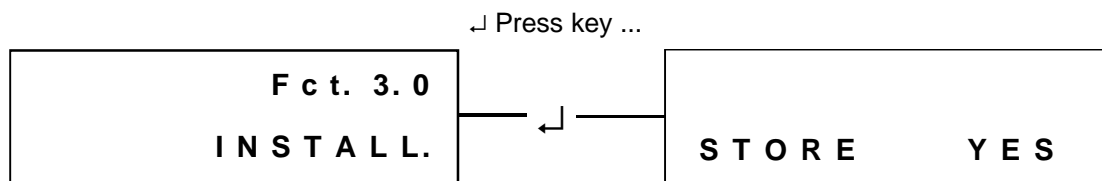

New parameters not to be stored

Press ↑ key to display "STORE.NO".
 Measuring mode continued with the "old" parameters after pressing the ↵ key; the "START" message is shown until a measured value is determined.

If instead you wish to return to Configuration, press the ↑ key first until "RETURN" is displayed, and then the ↵ key.

Store new parameters

Confirm by pressing the ↵ key, "START" is displayed, and the measuring mode is continued with the new parameters.

Examples of key functions

The cursor (flashing part of display) is shown boxed in by dotted lines in the following description.

To change numbers

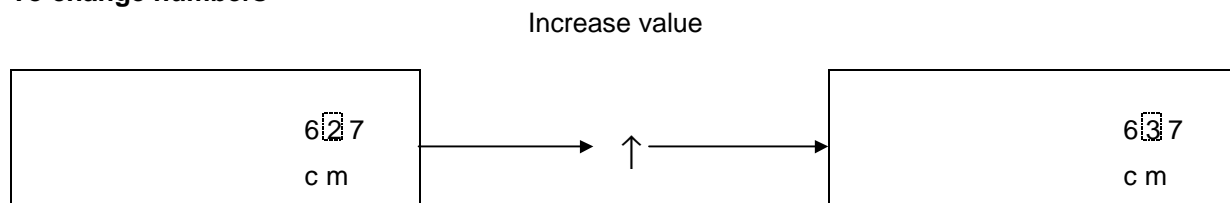

To shift cursor (flashing position)

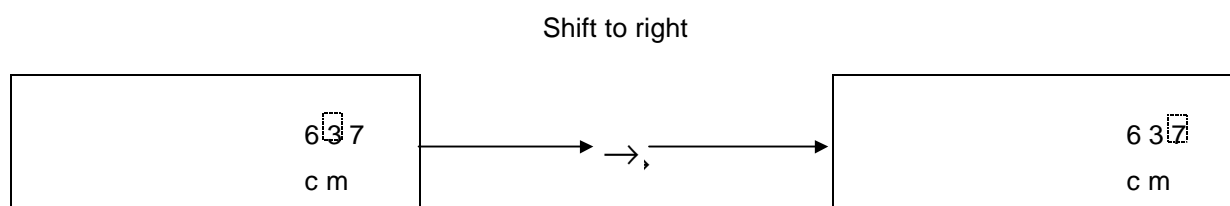

To change the text

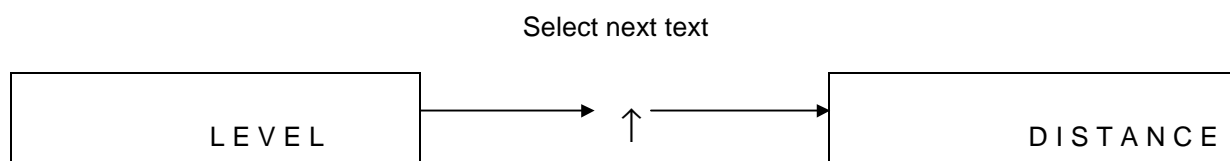

To change the unit (tank height)

Numerical values are converted automatically

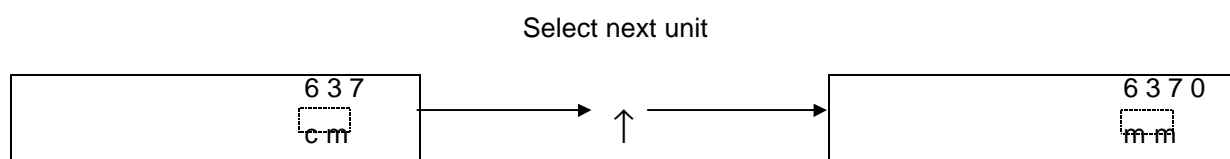

To revert from unit to number setting

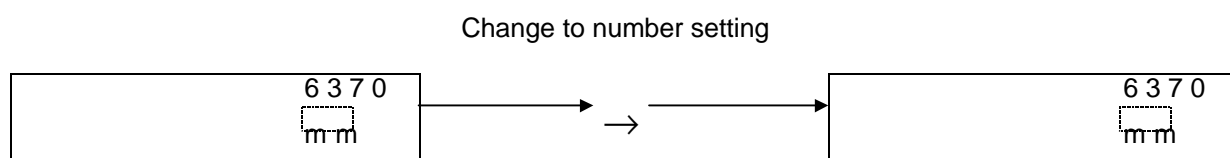

To revert to function display

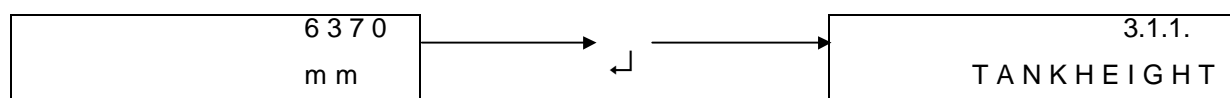

8.4 Table of settable functions (Versions 3.00, 3.01, 3.02, 3.03, 4.02, 4.03)

Function (Fct.)	Enter range	Default value	Description
1.0 OPERATION			
1.1 DISPLAY			
1.1.1 FCT.DISP	Options LEVEL DISTANCE CONVERSION REFLECTION	LEVEL	Select function of display (value to be displayed).
1.1.2 UNIT.LENGTH	Options m cm mm inch Ft PERCENT BARGRAPH	Meter [m]	Select unit for value of length to be displayed (level/distance).
1.1.3 UNIT. CONV.	Options m3 l US Gal GB Gal Ft3 bbl PERCENT BARGRAPH USER UNIT	Cubic meter [m3]	Select unit for conversion value to be displayed ("volume table").
2.0 TEST			
2.1 HARDWARE			
2.1.1 MASTER	Special function		Tests the hardware of the master.
2.1.2 DISPLAY	Special function		Tests the hardware of the display.
2.1.3 STATUS	Options Module DIS Module MW		Displays ID-Number and Status Bytes
2.2 CUR.OUTPUT			
2.2.1 VALUE I	Value display		Displays the actual value of the current output.
2.2.2 TEST I	Options 2 mA 4 mA 6 mA 8 mA 10 mA 12 mA 14 mA 16 mA 18 mA 20 mA 22 mA	2 mA	Output of selected value to the current output. IMPORTANT !!! With safety inquiry because of direct access to the current output !!! (Exi = min. 3.6 mA)
2.3 SW.OUTPUT			
2.3.1 TEST S	Options OPEN CLOSED	OPEN	Switching output on/off. IMPORTANT !!! With safety inquiry because of direct access to the switching output !!!
2.4 FIRMWARE			
2.4.1 MASTER	Display		Displays the firmware version of the master.
2.4.2 DISPLAY	Display		Displays the firmware version of the display.
3.0 INSTALL.			
3.1 BASIS.PARAM			
3.1.1 TANKHEIGHT	Options, unit m cm mm inch Ft Enter 0.50 [m] ... max. tank height	m 10.00 m* / 20.00 m *	To input the tank height. The tank height is defined as the vertical distance between the bottom edge of the flange and the tank bottom. The unit entered here is also used for all other length inputs.
3.1.2 BLOCKDIST	Enter 0.10 [m] ... tank height	0.50 m *	To input the block distance. The block distance marks the non-measurable range below the bottom edge of the flange.
3.1.3 ANTENNA	Options STANDARD WAVE STICK	STANDARD *	Selection of the antenna type. (WAVE STICK only for BM 70 A)
3.1.4 ANT.EXTENS.	Enter 0.00 [m] ... Tank height	0.00 m *	To input the length of the antenna extension.
3.1.5 DIST.PIECE	Enter 0 ... 2000 [mm]	0 mm *	To input the length of the flange distance piece in [mm] (high-temperature version = 120 mm).

Function (Fct.)	Enter range	Default value	Description
3.1.6 STILLWELL	Options NO YES If "YES": Enter (restraint) STILLWELL DIA. 25 ... 200 [mm]	NO 100 mm	Select: with or without stilling well. When "YES" selected, the inside diameter of the stilling well is additionally entered in [mm].
3.1.7 REF.OFFSET	Enter -10.00 ... + 10.00 [m]	0.00 m	To input the reference offset (relocation of the upper reference point).
3.1.8 TB. OFFSET	Enter -100.00 ... + 100.00 [m]	0.00 m	To input the tank bottom offset (relocation of the lower reference point).
3.2 DISPLAY			
3.2.1 FCT.DISP.	Options LEVEL DISTANCE CONVERSION REFLECTION	LEVEL	Select function of the display (value to be displayed).
3.2.2 UNIT.LENGTH	Options m cm mm inch Ft PERCENT BARGRAPH	Meter [m]	Select unit for length value to be displayed (level/distance). The unit selected here is used only for display of length values.
3.2.3 UNIT.CONV.	Options m3 l US Gal GB Gal Ft3 bbl PERCENT BARGRAPH USER UNIT	Cubic meter [m3]	Select unit for conversion values to be displayed ("volume table"). The unit selected here is used only for display of the conversion value.
3.2.4 USER UNIT	Text entry 10 ASCII characters	_____	Input of freely programmable unit for the conversion table (max. 10 characters).
3.2.5 ERROR MSG.	Options NO YES	YES	Select whether error messages are to be shown in the display.
3.3 SIGNAL.OUTPUT.			
3.3.1 FUNCTION I	Options OFF LEVEL DISTANCE CONVERSION REFLECTION SW.OUTPUT.	LEVEL	Select function of the current output (measured value to be displayed, or OFF = current output switched off = constant 4 mA).
3.3.2 RANGE I	Options 4-20 mA/E22 4-20 mA/E2 4-20 mA	4-20 mA/E22	Select the range for the current output and error output.
3.3.3 SCALE 4 mA	Enter -200.00 ... +200.00 [m] 0.00 ... 99999.99 [m ³] 0 ... 100 [Refl.]	0.00 m ₃ 0.00 m ³ 0	Input the lower range value for output to the current output. (Input is dependent on the selected function of the current output. The values for level and distance include the tank bottom and reference offset, resp.).
3.3.4 SCALE 20 mA	Enter -200.00 ... +200.00 [m] 0.00 ... 99999.99 [m ³] 0 ... 100 [Refl.]	10.00 m * 10.00 m ³ 100	Input of the full-scale range for output to the current output. (Input is dependent on the selected function of the current output. The values for level and distance include the tank bottom and reference offset, resp.).
3.3.5 BAUDRATE	Options 1200 Bd. 2400 Bd. 4800 Bd. 9600 Bd. 19200 Bd. 38400 Bd.	19200 Bd. *	Select the baud rate for the Communication interface (not relevant to HART [®] via current output). (For Fct. 3.3.7 = PROFIBUS-PA or F.FOUND.: deviating options.)
3.3.6 ADDRESS	Enter 0 ... 255	0	Input of the device address for Communication. (For Fct. 3.3.7 = PROFIBUS-PA or F.FOUND.: deviating input range)
3.3.7 PROTOCOL	Options HART [®] KROHNE/PC (MODBUS) (PROFIBUS-PA) (F.FOUND.)	HART [®]	Select the Communications protocol. (only when appropriate hardware provided)

Function (Fct.)	Enter range	Default value	Description
3.4 USER DATA			
3.4.1 LANGUAGE	Options GB/USA, D, F, I, E, P, S	GB/USA *	Select language to be used in the display (English, German, French, Italian, Spanish, Portuguese, Swedish)
3.4.2 ENTRY CODE 1	Options NO YES	NO	Switch the access lockout for the configuration menu on/off.
3.4.3 CODE 1	Enter code	RRREEUUU	Input of the Entry Code.
3.4.4 LOCATION	Text	BM70A-00 BM70P-00	Input of a max. 8-character device identifier.
3.5 APPLICAT.			
3.5.1 AUTO TANKH.	Special function		Automatic determination of the tank height.
3.5.2 EMPTY.SPEC.	Options OFF ON RECORD	OFF *	Switch the empty-tank spectrum (profile of the empty tank) on/off, or make new recording.
3.5.3 TIMECONST.	Value 1 ... 100 [s] (BM 70 A) 10 ... 100 [s] (BM 70 P)	10 s (BM 70 A) 30 s (BM 70 P)	Input of the time constant for measured-value filtering (low-pass).
3.5.4 TRACING.VEL.	Value 0.01 ... 10.00 [m/Min] (BM 70 A) 0.01 ... 1.00 [m/Min] (BM 70 P)	0.50 m/min (BM 70 A) 0.10 m/min (BM 70 P)	Input of the maximum rate of change in the level that can occur in operation.
3.5.5 MULT.REFL.	Options NO YES	NO	Switch the multi-reflection identifier on/off.
3.5.6 BD-DETECT.	Options NO YES	YES	Switch the block distance (overflow) detector on/off.
3.5.7 FUNCT. FTB	Options OFF PARTIAL FULL	OFF	Select function of the tank bottom tracking system. (FULL for BM 70 A only)
3.5.8 EPSILON R	Enter 1.1000 ... 8.0000	2.0000	Input of the relative permittivity of the product for the tank bottom tracking system.
3.5.9 TANKTYPE	Options STORAGE TANK PROC.TANK. AGITATOR	PROC.TANK.	Select the tank type. (AGITATOR for BM 70 A only)
3.6 SW.OUTPUTS.			
3.6.1 FUNCTION S	Options OFF LEVEL DISTANCE CONVERSION REFLECTION ERROR OPEN ERROR CLOSED	ERROR OPEN	Select the function of the switching output.
3.6.2 TYPE S	Option HIGH LOW	HIGH	Select type of limit value for the switching output. (not applicable to Function OFF, ERROR OPEN or ERROR CLOSED)
3.6.3 THRESHOLD	Value -200.00 ... +200.00 [m] 0.00 ... 99999.99 [m ³] 0 ... 100 [Refl.]	5.00 m 5.00 m ³ 50	Input of the threshold value for the switching output. (Input is dependent on the function of the switching output. The values for level and distance include the tank bottom and reference offset, resp.)
3.6.4 HYSTERESIS	Value 0.00 [m] ... Tank height 0.00 ... 99999.99 [m ³] 0 ... 100 [Refl.]	0.10 m 0.10 m ³ 10	Input of the hysteresis for the switching output. (Input is dependent on the function of the switching output.)

*: Default values following a parameter reset (use of a new EEPROM not yet described).
The factory setting for the parameters marked with * is dependent upon the device version and customer specifications (if the tank height is known at the time the order is placed).

8.5 Configuration examples

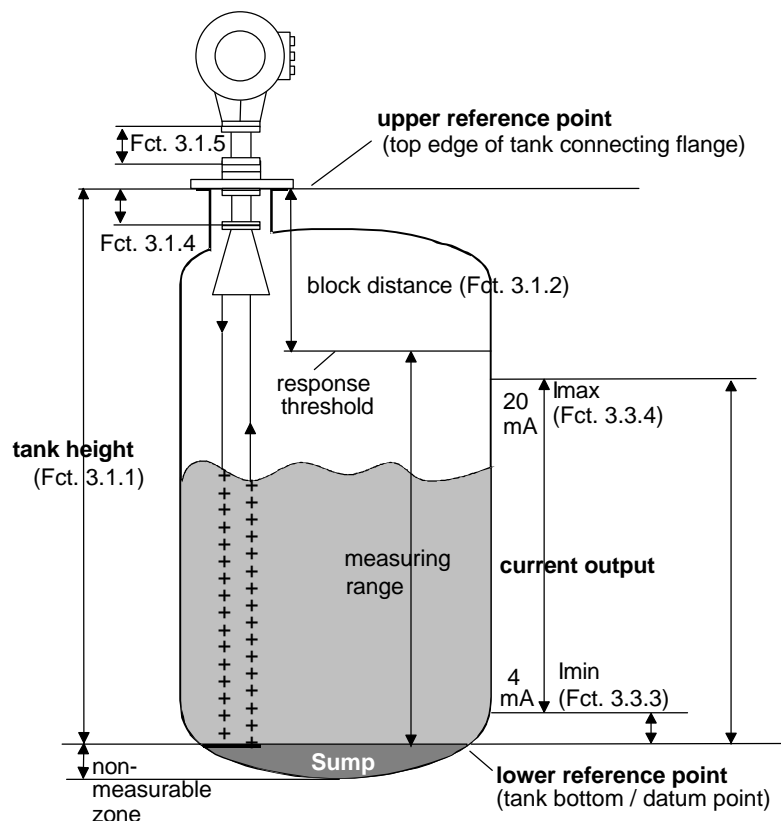

8.5.1 Level measurement (example)

Tank height (Fct. 3.1.1): 6.00 m

Antenna extension (Fct. 3.1.4): 0.20 m

Block distance (Fct. 3.1.2): 0.70 m

Response threshold or maximum measurable level = 5.30 m (calculated from lower reference point)

$$\begin{aligned}
 &= \text{tank height} - \text{block distance} \\
 &\quad (\text{Fct. 3.1.1}) \quad (\text{Fct. 3.1.2}) \\
 &= 6.00 \text{ m} - 0.70 \text{ m}
 \end{aligned}$$

Current output I	Function I (Fct 3.3.1):	LEVEL
	Range I (Fct. 3.3.2):	4 - 20 mA
	Scaling 4 mA (Fct. 3.3.3):	0.00 m, equivalent to 4 mA
	Scaling 20 mA (Fct. 3.3.4):	5.00 m, equivalent to 20 mA

Switching output	Function S (Fct. 3.6.1):	LEVEL
	Type S (Fct. 3.6.2):	LOW (= below threshold)
	Threshold (Fct. 3.6.3):	5.00 m
	Hysteresis (Fct. 3.6.4)	0.10 m

Display	Function, display (Fct. 3.2.1):	LEVEL
	Unit, length (Fct. 3.2.2):	m (meters)

Please note Display and outputs can also be used for different measured variables, e.g.: display for conversion, current output I for level, and switching output S for error messages.
The value for Scaling 20 mA should not be greater than the response threshold.

8.5.2 Volume measurement (example)

- In order to be able to measure volume with the BM 70 A/P, a conversion table (volume table) needs to be compiled with the PC-CAT program (see Sect. 8.12).
- By means of the volume table, various levels are allocated to specific volumes previously calculated or measured out.
- In the case of non-symmetrical tanks, e.g. tanks with dished bottom, the accuracy of volume measurement will depend on the number of set "level/volume pairs". The maximum number of pairs (points) that can be set is 50; the volume is linearly determined (interpolated) between 2 points.
- In the following **example**, 4 data pairs have been programmed.

Volume table	Unit volume (Fct. 3.2.3): m ³ Set table (PC-CAT):	Point	Level	Volume
		①	0.00 m	0.25 m ³
		②	0.25 m	0.70 m ³
		③	0.50 m	1.40 m ³
		④	5.30 m	16.80 m ³
Tank height (Fct. 3.1.1):	6.00 m			
Antenna extension (Fct. 3.1.6):	0.20 m			
Block distance (Fct. 3.1.2):	0,70 m			
Response threshold, maximum measurable level = 5.30 m, equivalent to a volume of 16.80 m³ (calculated from lower reference point)				
	= tank height - block distance (Fct. 3.1.1) (Fct. 3.1.2)			
	= 6,00 m - 0,70 m			
Current output I	Function I (Fct 3.3.1): Range I (Fct. 3.3.2): Scaling 4 mA (Fct. 3.3.3): Scaling 20 mA (Fct. 3.3.4):	CONVERSION 4 - 20 mA 0.00 m ³ , corresponds to 4 mA 16.80 m ³ , corresponds to 20 mA		
Switching output	Function S (Fct. 3.6.1): Type S (Fct. 3.6.2): Threshold(Fct. 3.6.3): Hysteresis (Fct. 3.6.4)	LEVEL LOW (=if level drops below threshold) 5.00 m 0.10 m		
Display	Function, display (Fct. 3.2.1): Unit, conversion (Fct. 3.2.2):	CONVERSION m ³ (cubic meter)		

8.6 Description of functions

8.6.1 Choice of units

Level/distance units

Select under Fct. 3.1.1 TANKHEIGHT

- m
- cm
- mm
- inch
- Ft

The unit selected here is also valid for the following functions:

- Block distance Fct. 3.1.2
- Antenna extension, Fct. 3.1.4
- Scaling 4 mA value, current output, Fct. 3.3.3
- Scaling 20 mA value, current output, Fct. 3.3.4
- Range for partial tank bottom tracing, Fct. 3.5.2
- Threshold (limit value), switching output, Fct. 3.6.3
- Hysteresis, switching output, Fct. 3.6.4
- Tracking speed, Fct. 3.5.4
(in m/min when Fct.3.1.1 = m, cm or mm
or in ft/min when Fct.3.1.1 = inch or ft)

The Fct. 3.2.2 (length unit for display) can be set independently of the unit selected under Fct. 3.1.1.

Conversion units

By conversion is meant the transposition of an arbitrary level value into a "conversion value" (usually volume), so as, for example, to realize a non-linear function as a factor of the level.

Options under Fct. 3.2.3 UNIT.CONV.

- m³
- l (= litres)
- US Gal
- GB Gal (Gal = gallons)
- Ft³
- bbl (petroleum barrels)

The unit selected here is also valid for the following functions:

- Scaling 4 mA value, current output, Fct. 3.3.3
- Scaling 20 mA value, current output, Fct. 3.3.4
- Threshold (limit value), switching output, Fct. 3.6.3
- Hysteresis, switching output, Fct. 3.6.4
- Display range:
 - 0.00 - 30000.00 m³
 - 0 - 9999999 Liter
 - 0 - 7925161 US Gal
 - 0 - 6599265 GB Gal
 - 0.0 - 999999.9 Ft³
 - 0.0 - 99999.9 bbl (petroleum barrel)

Note: When the display is set to Liter, ft³ or Barrel, it is possible that the max. volume will no longer be shown. In such cases, the special symbol "==" is displayed and a change possibly made to a different unit. The current output will in any case output the correct value.

Conversion measurement requires that a conversion table be set with the PC-CAT program. By means of this table a conversion value is allocated to each level value (level / conversion pairs). The values are linearly established (interpolated) between 2 points.

Also, for the local display an arbitrary (max. 10-character) text (Fct. 3.2.4) can be defined as a unit under Fct. 3.2.4. Internally, this "user unit" is treated in the conversion in the same way as "m³".

Examples of application and setting: see Sect. 8.5

Reflection units

The measuring range for "reflection" has a fixed setting of 0...100 (whole numbers). The "reflection" measured value is a relative measure of the strength of the reflected signal, converted into an exponential scale: each number step is approximately equivalent to a change by 0.4 dB; in other words, about 8 steps signify a doubling of the signal strength. At full reflection, a value of approx. 90...100 is measured.

Where measuring distances are greater, the natural weakening of the signal is automatically allowed for in the measured value (does not apply to stilling wells, i.e. when Fct. 3.1.6 = YES).

The measured reflection can be regarded as being a measure of the reflectivity of a product.

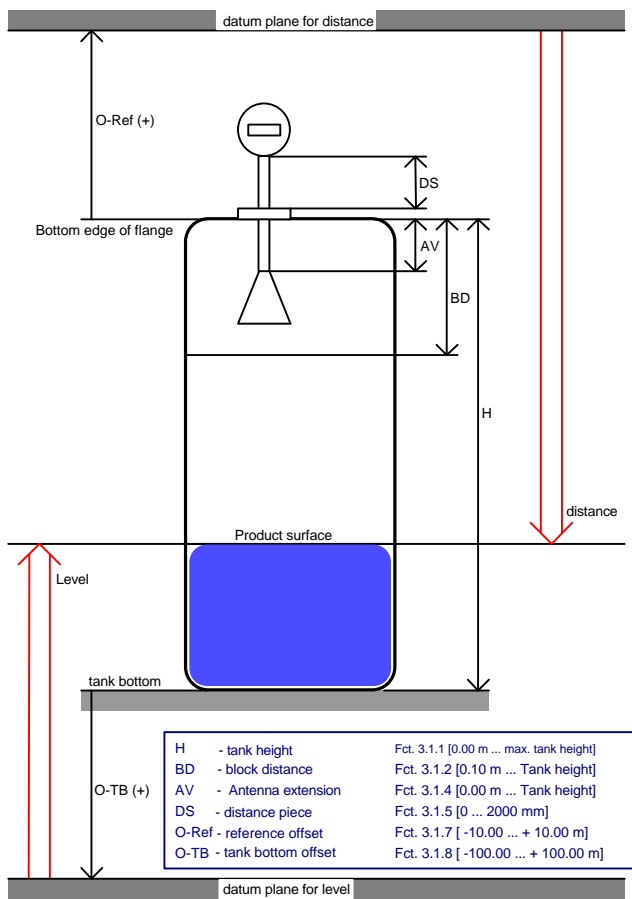

8.6.2 Vessel (tank) height

Fct. 3.1.1 TANKHEIGHT

- Definition of the tank height for the BM 70 A/P:
Distance between the top edge of the tank fitting and the lower reference point.
- The lower reference point is that "point" in the vessel on which the microwaves emitted by the BM 70 A/P impinge and from which they are reflected. This can be the tank bottom (symmetrical tank with flat bottom) or the non-horizontal part of the bottom (e.g. tank with dished bottom) or an additionally fitted plate. The BM 70 A/P cannot measure below the lower reference point (usually a "sump" is left in the tank, see diagram in Sect. 8.5).
- Selection of unit, see Sect. 8.6.1.
- Setting ranges for the tank height BM 70 A (standard):
 - 00.50 - 40.00 m
 - 0050 - 4000 cm
 - 00500 - 40000 mm
 - 0019.7 - 1574.74 inch
 - 001.64 - 131.22 ft

For BM 70 P: max. 35m / 1377.9 inch / 114.8 ft

- Depending on the version, it is also possible to set an upper limit for the tank height (e.g. Wave-Stick: 20 m). The maximum value can be increased by KROHNE Service to up to 100 m. (For BM 70 A only)
- The tank height set at this point is simultaneously the upper limit of the setting ranges for the following functions:
 - Block distance, Fct. 3.1.2
 - Antenna extension, Fct. 3.1.4
 - Hysteresis, switching output, Fct. 3.6.4
- If the tank height is changed to a value greater than 30 m, a new empty spectrum must subsequently be recorded, see Sect. 8.6.12. (not applicable to BM 70P).

8.6.3 Block distance, antenna type and antenna extension

Fct. 3.1.2 BLOCKDIST

- Caked deposits or contamination of the antenna, for example, can cause faulty measurements directly below the antenna. The function "block distance" is used to specify a zone below the flange in which measurements are not to be carried out.
- Signals within the block distance are suppressed; a rise in the level above this limit will result in a measurement corresponding to a distance = block distance, when Fct. 3.5.6 BD-DETECT = ON.
- Unit and setting range: same as Fct. 3.1.1 TANKHEIGHT.
- Recommended minimum value (see also Sect. 3.3):
 - for "Wave-Stick": 200 mm
 - for stilling wells and "Wave-Stick SW":
antenna length + 300 mm
 - all other versions in storage tanks:
antenna extension + antenna length + 100 mm
 - all other versions in process tanks:
antenna extension + antenna length + 200 mm

Fct. 3.1.3 ANTENNA

- The antenna type is factory-set here.
- STANDARD (all versions incl. "Wave-Stick SW" but excl. "Wave-Stick")
- WAVESTICK (not for "Wave-Stick SW")
- BM 70 P: only STANDARD setting possible.

Fct. 3.1.4 ANT.EXTENS.

The length of the supplied antenna extension is factory-set here.

- Unit and setting range: same as Fct. 3.1.1 TANKHEIGHT.

This setting may only be changed when a longer or shorter antenna extension is installed. Otherwise faulty measurements may result because the BM 70 A/P allows for this length when measuring. After changing any antenna extension, record a new empty spectrum, see Sect. 8.6.12. When a curved antenna extension is used, only the vertical component (vertical offset) should be entered here.

Example (S-shaped extension): Fct. 3.1.4 = 323 mm.

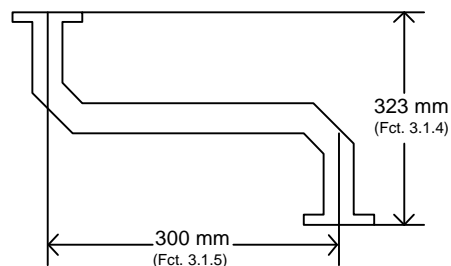

8.6.4 Distance piece

Fct. 3.1.5 DIST.PIECE

The length of any supplied distance piece above the mounting flange is factory-set here.

- Setting range: 0 ... 2000 mm
- Default value: 0 mm

The value of 120 mm should be entered for the high-temperature version of the flange system.

When a curved antenna extension is used, the horizontal component of this extension should additionally be entered (= geometric length of the pipe minus the vertical offset).

Example (see drawing above): Fct. 3.1.5 = 300 mm.

8.6.5 Stilling well

Fct. 3.1.6 STILLWELL

If the device is operated with a stilling well, the option Stilling well = YES and the inside diameter of the pipe should be entered here in mm.

- NO : operation without stilling well
- YES : operation with stilling well

If YES has been selected, proceed with ↵ and enter the inside diameter:

- Setting range: 25 ... 200 mm
- Default value: 100 mm

If the diameter of the stilling well is greater than 200 mm, enter the maximum value = 200 mm.

8.6.6 Reference and tank bottom offsets

Fct 3.1.7 REF. OFFSET

An arbitrary reference offset is added to the measured distance (positive when the reference point is above the flange; negative when the reference point is below the flange): see Example 1 below. The offset is effective for all distance values (local display, current output, switching output, digital information).

- Setting range: -10 m ... +10 m (32.8 ft)
- Default value: 0

Fct 3.1.8 TB.OFFSET

An arbitrary tank bottom offset is added to the measured level (positive, when the reference point is below the set tank height; negative, when the reference point is above the tank bottom): see Examples 2 and 3. The offset acts on all level values (local display, current output, switching output, conversion table, digital information).

- Setting range: -99.99 m ... +99.99 m (328 ft)
- Default value: 0

Examples of setting the reference offset and tank bottom offset:

Example 1: Reference point for distance measurement (ullage) differs from flange position (in the example, 1 m above the flange). Let the tank height be $H = 6$ m.

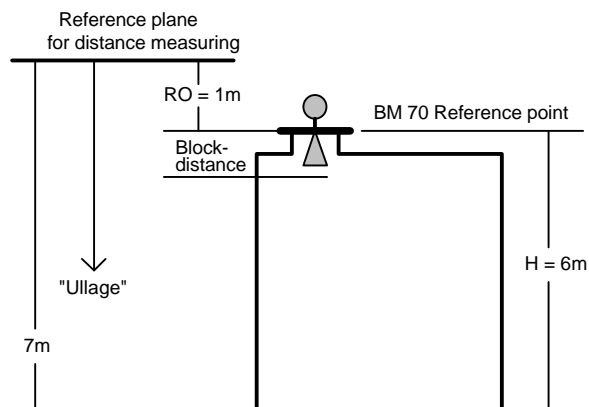

Input the following parameters:

Tank height = 6 m
Reference offset = + 1 m
Tank bottom offset = 0

The possible measuring range is:
Distance = (1 m + block distance) to 7 m.

Example 2: Reference point for level measurement differs from the programmed tank bottom position (in the example, 2 m below the tank bottom). Let the tank height be $H = 6$ m.

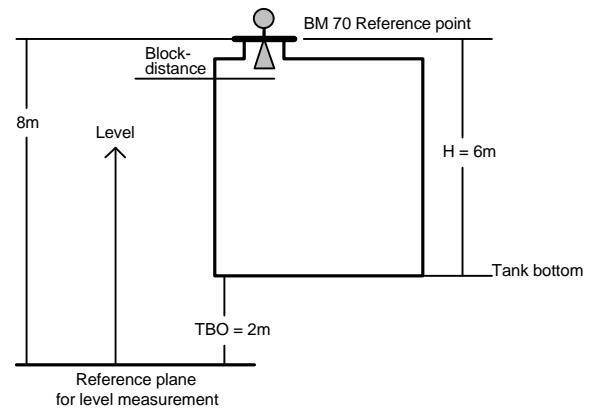

Input the following parameters:

Tank height = 6 m
Tank bottom offset = + 2 m
Reference offset = 0

The possible measuring range is:
Level = 2 m to (8 m - block distance).

Example 3: Only a specific part of the level in a very tall tank is to be measured (in the example, levels 50m ... 60m).

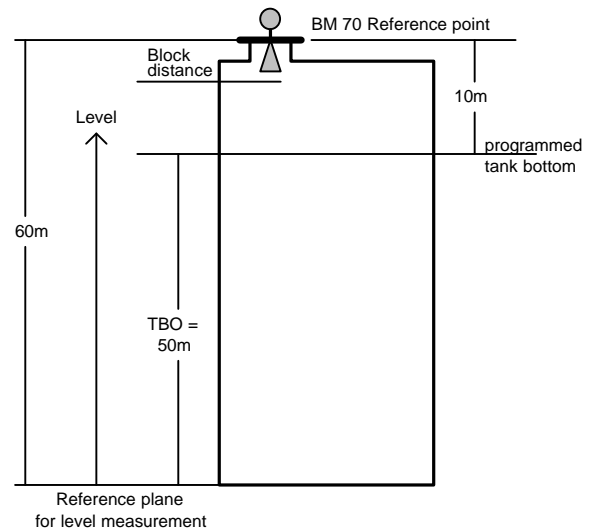

Input the following parameters:

Tank height = 10 m
Tank bottom offset = + 50 m
Reference offset = 0

The possible measuring range is:
Level = 50 m to (60 m - block distance).

8.6.7 Display

Fct. 3.2.1 (or Fct. 1.1.1) FCT.DISP.

This function is used to select the measured variable.

- LEVEL
 - DISTANCE
 - CONVERSION
 - REFLECTION
- } Measuring range, see Figure in Sect. 8.5.

If the conversion value is to be displayed, a conversion table must be programmed first otherwise a parameter error will occur.

Fct. 3.2.2 (or Fct. 1.1.2) UNIT.LENGTH

Use this function to select the unit for displaying level and distance.

- m
- inch
- PERCENT
- cm
- Ft
- BARGRAPH
- mm

The "percent display" refers to the scaling range of current output I. Therefore the current output must also be set to level or distance, otherwise a parameter error will occur.

Under "Bargraph", a maximum of 25 segments are displayed in the form of vertical lines in the first line of the display (0% = 1 segment, 100% = 25 segments).

Fct. 3.2.3 (or Fct. 1.1.3) UNIT.CONV.

Use this function to select the unit for conversion display.

- m3
- US Gal
- ft3
- PERCENT
- User Unit (see Fct. 3.2.4)
- litres
- GB Gal (Gal = gallons)
- bbl (petroleum barrels)
- BARGRAPH

The "percent display" refers to the scaling range of current output I. Therefore the current output must also be set to conversion, otherwise a parameter error will occur.

Under "Bargraph" in the first line of the display a maximum of 25 segments as vertical lines are displayed (0% = 1 segment, 100% = 25 segments).

Fct. 3.2.4 USER UNIT

Enter the text for the conversion "user unit" (see Fct. 3.2.3) here. It consists of a maximum of 10 alphanumeric characters.

- Characters assignable to each of the 10 places:
 - alpha characters A-Z / a-z
 - numbers 0-9 or
 - special signs + -
 - blank characters (= underscore)

Fct. 3.2.5 ERROR MSG.

Use this function to select whether errors are to be displayed during measurement.

- NO Error messages shown only in the error list, see Sect. 8.8
- YES When errors occur during measurement, display of the measured value will alternate with error messages.

8.6.8 Current output I

Fct. 3.3.1. FUNCTION I

Use this function to select the measured variable.

- OFF (= deactivated, the output supplies a constant 4 mA, e.g. necessary for HART® Multidrop; Fct. 3.3.2 to 3.3.4 cannot then be selected, i.e. they are skipped over).
- LEVEL
- DISTANCE
- CONVERSION
- REFLECTION
- SW.OUTP. (function and switching threshold are set in Fct. 3.6).

Fct. 3.3.2 RANGE I

Use this function to define the current in error condition.
E = Error at 2 mA or 22 mA.

- 4-20 mA (hold last measured value when error occurs)
- 4-20 mA/E=2 (min. 3.6 mA for Ex-i output!)
- 4-20 mA/E=22

Fct. 3.3.3 SCALE 4 mA

- This function does not appear (is skipped over) when "OFF" is set under Fct. 3.3.1.
- This function is used for $I_{\min} = 4$ mA to define the lower value for level, distance, conversion or reflection (scaling 4 mA).
- Setting LEVEL or DISTANCE under Fct. 3.3.1:
Setting range and unit for SCALE 4 mA same as for Fct. 3.1.1 TANKHEIGHT. If a reference or tank bottom offset is set, this must be allowed for!
- Setting CONVERSION under Fct. 3.3.1:
Unit for SCALE 4 mA same as in Fct. 3.2.3 UNIT.CONV. But value must be smaller than the maximum value in the conversion table.
- Setting REFLECTION under Fct. 3.3.1:
The setting range for SCALE 4 mA is 0...99.

Fct. 3.3.4 SCALE 20 mA

- This function does not appear (is skipped over) when "OFF" is set under Fct. 3.3.1.
- This function is used for $I_{\max} = 20$ mA to define the upper value for level, distance, conversion or reflection (scaling 20 mA)
- Setting LEVEL or DISTANCE under Fct. 3.3.1:
Setting range and unit for SCALE 20 mA as for Fct. 3.3.1 TANKHEIGHT. The value set here should not be greater than the response threshold. (Response threshold = tank height (Fct. 3.1.1) - block distance (Fct. 3.1.2)). If a reference or a tank bottom offset is set, this must be allowed for!
- Setting CONVERSION under Fct. 3.3.1:
Unit for SCALE 20 mA same as in Fct. 3.2.3 UNIT.CONV. The value set here must be greater than that of Fct. 3.3.3, otherwise error during Parameter Check.
- Setting REFLECTION under Fct. 3.3.1:
The setting range for $I_{\max} = 20$ mA is 1...100. The value set here must be greater than that of Fct. 3.3.3, otherwise error during Parameter Check.

Application and setting examples: see Sect. 8.5

8.6.9 Communication interfaces

Fct. 3.3.5 BAUDRATE

- This function defines the transmission rate for RS 485 Communication.
 - 1200 Bd.
 - 2400 Bd.
 - 4800 Bd.
 - 9600 Bd.
 - 19200 Bd.
 - 38400 Bd.

Default value = 19200 bauds

- For devices with PROFIBUS-PA (Ex-i) output the value has been set to 31250 bauds. and cannot be changed.
- The value set here is not relevant for digital Communication via the current output (e.g. HART®). For this, 1200 bauds are on principle processed, independent of the setting in Fct. 3.3.5!

Fct. 3.3.6 ADDRESS

- This function is used for entering valid addresses from 0 to 255 (PROFIBUS: 0 to 126).
- If several devices are operated on one digital bus or via HART®-Multidrop, each device must be set to an individual address under which it can then be addressed in the bus.
- The default value is the address "0".

Fct. 3.3.7 PROTOCOL

The following Communications protocols are available:

HART®:

The HART® protocol is a Communications protocol of the "HART® Communication Foundation". In addition to the "universal commands" and "common practice commands" there are "device-specific commands" for access to all parameters and functions of the BM 70 A/P. In addition there is the "device description" (DD) for BM 70 A/P, which can be used for universal HART® control units, such as the HART® Communicator or SIPROM.

The standard hardware platform for HART® is the current output 4-20 mA with superimposed FSK signals. For HART®-Multidrop (max. 15 devices on one bus), the version with Ex-i current output, set to a constant 4 mA (Fct. 3.3.1 = OFF) should be selected.

KROHNE/PC (KROHNE protocol):

The standard Communications protocol between the BM 70 A/P and the evaluation system is the standardized KROHNE protocol, which allows all dynamic values and setting parameters to be read and changed. If the BM 70 A/P is connected to existing user systems, this protocol must be applied to such systems. The protocol can also be used when the BM 70 A/P is connected to the KROHNE Tank Inventory System. For further information, please ask for the "BM70A/P PC Communication" description.

MODBUS:

(not yet included in V. 3.00/3.01/4.00)

The Modbus protocol constitutes a quasi-standard for linking to programmable logic controls (PLC) and other systems. The BM 70 A/P uses the Modbus RTU Protocol with extended facilities to permit access to all dynamic values and setting parameters. For further information, please ask for the "BM70A/P Modbus" description.

PROFIBUS-PA:

(special signal output required)

The PROFIBUS-PA is defined and standardized in DIN 19245, Parts 1 and 2. A large number of devices with PROFIBUS-PA capability are available on the market. The BM 70 A/P is easy to connect to such bus systems; it has a purely slave function and allows access to all dynamic values and to setting parameters. The hardware interface we use is the intrinsically safe bus interface.

For further information, please ask for the "BM70A/P PROFIBUS-PA" description.

F.FOUND.:

(special signal output required)

Bus interface in conformity with the "Foundation Fieldbus" (FF). For further information, please ask for the "BM70A/P Foundation Fieldbus" description.

- in preparation -

8.6.10 Display

Language of display texts

A choice of languages for the display texts is offered in

Fct. 3.4.1.

- GB/USA English
- D German
- F French
- I Italian
- E Spanish (Español)
- P Portuguese
- S Swedish

Coding desired for entry into setting level?

Set NO or YES in Fct. 3.4.2 ENTRY.CODE1.

- If NO set, simply press key → to get into the setting level.
- If YES set, press key → and then a 9-keystroke combination to get into the setting level.
- Factory-set Entry Code 1:
→ → → ↵ ↵ ↵ ↑ ↑ ↑
- To change Entry Code 1
Select Fct. 3.4.2 *ENTRY CODE 1*: set to YES.
Select Fct. 3.4.3 CODE 1.
Press key → , display shows: CODE 1 _ _ _ _ _

Key-in required 9-keystroke combination; each keystroke confirmed by "*". Then press the **same** keystroke combination again. "WRONG CODE" (= incorrect entry) appears if 1st and 2nd entries are **not equal**.

Press keys ↵ and → and repeat entries.

Take good note of the selected entry code!

Measuring-point identification (tag name)

- A max. 8-figure tag name can be set under Fct. 3.4.4 LOCATION (e.g. L123 A53)
- Characters assignable to each of the 8 places:
alpha characters A-Z / a-z; numbers 0-9;
special signs: + - ; blanks (= underscore character)

Factory setting: BM70A-00 or BM70P-00

8.6.11 Auto tank height

FCT. 3.5.1 AUTO TANKH.

With this function the height of the tank can be determined by the BM 70 A/P itself, provided the following conditions are met:

- The tank has been completely drained for at least 2 minutes.
- The tank bottom has good reflectivity (not suitable for dished and tapered bottoms without reference plate).
- The functions Fct. 3.1.3 (antenna), Fct. 3.1.4 (extension), Fct. 3.1.5 (distance piece) and Fct. 3.1.6 (stilling well) must previously have been correctly set.
- If the tank is taller than 30 m, the approximate tank height must previously be set manually with Fct. 3.1.1, as otherwise the measuring range will not suffice to locate the bottom.

After pressing the → key the display shows the currently measured value for the tank height. Press key ↵; the inquiry "SURE NO" now appears. If you are not sure whether the measured value coincides with the true tank height, reject the value by pressing key ↵.

If the measured value seems plausible for the tank height and you wish to store it, change the option to "SURE YES" by pressing key ↑, and then press key ↵.

If the message: NO MEAS.VAL. appears, this means that the quality of measurement is not adequate (inadequate bottom reflection or too many interferences) for automatic determination of the tank height. Press key ↵ to abort the operation. In this case you will need to enter the tank height manually with Fct. 3.1.1.

8.6.12 Empty spectrum

What is an empty spectrum ?

- Fixed and moving internals in the tank (including perhaps the tank wall) produce interference signals (reflections) that can result in incorrect measurements.
- To enable the BM 70 A/P to identify and blank out such interference signals, the tank profile (empty spectrum) needs to be recorded once only prior to (initial) startup.
- For this purpose, the tank should if possible be completely empty and all moving parts (e.g. agitators) switched on. If these conditions cannot be met during startup, the tank profile (empty spectrum) can also be recorded at a later time. Until it is recorded, however, measurements may be inaccurate.
- Recording of the tank profile involves 1000 measurements that are carried out by the BM 70 A/P and stored in the form of a so-called "empty spectrum".
- This allows the BM 70 A/P to discriminate between constant or regularly recurring interference signals and the actually useful or wanted signals (level). Interference signals are suppressed and only the useful signal is processed.
- If no appreciable interference from internals is to be expected, recording of the empty spectrum can also be omitted, because a partial empty spectrum (see below) of the flange system has been stored by the factory.

Recording of the empty spectrum (sequence, example)

Key	Displayed	Description
→	1.0	OPERATION
2 x ↑	3.0	INSTALL.
→	3.1	BASIS.PARAM.
4 x ↑	3.5	APPLICAT.
→ ↑	3.5.2	EMPTY.SPEC. ON
→		Partial empty spectrum already recorded by factory
↑		RECORD
↓		AVERAGE
		Factory-set is here AVERAGE (= normal empty spectrum). This setting is suitable for most applications (possible alternative)
↑		MAX. VALUES
↓		TOTAL
		Recording of the empty spectrum over the full range.
↑		PARTIAL
		If the tank cannot be drained over the full range
↓		40000 mm
		Enter distance value down to which the empty spectrum is to be recorded.
↓		WAIT 1000...0
		Empty spectrum being recorded. Duration: approx. 1.5 minutes. Countdown is from "1000" to "0".
↓	3.5.2	READY EMPTY.SPECT.
		After 1.5 minutes. Tank profile recorded.
4 x ↓		Revert to measuring mode with display of actual level, distance or conversion. Empty spectrum is now stored and will be taken into consideration for measurements.

FCT. 3.5.2 EMPTY.SPEC.

Under this function the empty spectrum is activated or deactivated, or recorded and stored. The display first gives information as to whether the empty spectrum is currently switched ON or OFF. You can then choose between:

- OFF: The empty spectrum is not considered for measurements but remains stored in the BM 70 A/P and can be activated again at a later date.
- ON: The empty spectrum is (again) activated and considered for measurements.
- RECORD: The previous empty spectrum is to be deleted and a new one recorded.

Conditions:

- Tank must be totally or partially drained.
- All moving parts, e.g. agitators, must be switched on.
- Tank height, antenna extension, distance piece and still well must be set correctly.

Note: where a **Wave-Stick** is involved

Due to an error in Firmware Version **3.00**, before the **empty spectrum** can be re-recorded, parameter 3.1.3 ANTENNA (see Section 8.6.3) must first be set to **STANDARD** and then set to **WAVE-STICK** after the empty spectrum recording has been made. If these directions are not observed, the "SPECT.ERR" error will be indicated, and the recording will need to be carried out again (correctly). This error has been rectified in subsequent firmware version (V. 3.01 and higher), and the empty tank spectrum can be recorded in the usual way for the Wave-Stick.

When you select "RECORD", the procedure is as follows: If other configuration parameters have previously been changed, you will first be asked by "STORE YES" whether you wish to store the data. Confirm by pressing key ↵.

The next step is a choice of the following:

- AVERAGE
Values are averaged. This setting can be used for most applications.
- MAX. VALUES
Only maximum values considered when the empty spectrum is recorded.
Of advantage in conjunction with "difficult" agitators, for example.

If the tank is not completely drained, the empty tank spectrum can nevertheless still be recorded up to a certain range. In this case, select menu item PARTIAL.

- After selecting AVERAGE or max. VALUES, press key ↵. Then select PARTIAL or TOTAL with key ↑, as follows.
- If TOTAL selected, the empty-tank spectrum is recorded over the complete range.
- If PARTIAL selected, interrogation is carried out via the ↵ key concerning input of the distance value up to which the empty-tank spectrum shall be recorded.
- The tank area below the current product level is excluded from the recording of the empty-tank spectrum.
- The distance value is entered in the same unit as used for the tank height, in the range of 0 m to tank height.
- It is recommended to maintain a safe distance of 20 to 30 cm (8" to 12") to the actual distance.

Subsequently press key ↵ to start recording of the empty-tank spectrum.

"WAIT" appears briefly in the display. Then countdown of measurements from "1000" to "0". "READY" is displayed after approx. 1.5 Minutes.

Press ↵ key 5 times to store the empty spectrum, which will then be taken into consideration during measurements.

Recording of the empty spectrum can be aborted by pressing key ↵. Displayed: BREAK. Confirm by pressing key ↵.

The "old" empty spectrum is retained in this case.

8.6.13 Time constant and tracking speed

Fct. 3.5.3 TIMECONST.

- New measured values are damped (filtered) with the time constant so as to avoid abrupt changes in measured values and thus also in the current output I and the display.
- Setting range: 001 - 100 Sec (BM 70 A)
010 - 100 Sec (BM 70 P)
- The tank bottom must supply a measurable reflection signal, so the method cannot be applied e.g. when a dished bottom is involved.
- Default value and recommended setting:
010 Sec (BM 70 A)
030 Sec (BM 70 P)

Fct. 3.5.4 TRACING.VEL.

To avoid faulty measurements, the BM 70 A/P places a symmetrical "plausibility range" around the last valid measured value in which the next measured value is expected. Measured values outside this range are identified as invalid and are suppressed.

If no valid measured value is identified, the BM 70 A/P enlarges the plausibility range with the tracing speed (Fct. 3.5.4) until a valid (plausible) measured value has again been found.

The measured value for level/distance cannot change at a faster rate than the set tracing speed.

- Under Fct. 3.5.4 the maximum rate at which the level can change in the tank should be set as the minimum value.
- Setting ranges:
BM 70 A
0.01 - 10.00 m/min (if Fct. 3.1.1. Unit m/ cm/ mm)
0.03 - 32.80 ft/min (if Fct. 3.1.1. Unit inch/ft)
BM 70 P
0.01 - 1.00 m/min (if Fct. 3.1.1. Unit m/ cm/ mm)
0.03 - 3.28 ft/min (if Fct. 3.1.1. Unit inch/ft)
- Default: 0.5 m/min (BM 70 A); 0.1 m/min (BM 70 P)
- See also Sect. 8.8 (error message: NO M.VALUE)

8.6.14 Multiple reflections and block distance detection

Fct. 3.5.5 MULT.REFL.

Multiple reflections frequently occur in storage tanks with an extremely calm surface, typically when the BM 70 A/P is mounted on a dome or centred on a "dished cover", or the vessel is fitted with a flat or only very slightly convex head.

Such multiple reflections tend to simulate lower-than-actual levels. In such cases, activate the multiple reflections identifier, and see also references in Sect. 8.8.

- NO (default)
Measurement **without** identification of multiple reflections.
- YES
Measurement **with** identification of multiple reflections.
A better solution, however, is to change the mounting location of the BM 70 A/P so as to prevent the occurrence of multiple reflections in the first place, or at least to diminish the strength of the multiple reflections (see Sect. 6.1.2).

To ensure satisfactory identification of the first measured value after the BM 70 A/P has been switched on, always carry out measurements with the "empty spectrum" (Fct. 3.5.2) when the "multiple reflection identifier" is activated, see Sect. 8.6.12.

Fct 3.5.6 BD-DETECT.

- NO
- YES (default)

To activate the block distance (overflow) detector:

So long as a significant signal is detected within the block distance, the measured value is "held" at the block distance limit. This avoids any possibility of the measured value skipping to a multiple reflection should the level rise into the block distance range.

The block distance can have a value that is at least equal to that specified in Sect. 8.6.3 as a recommendation!

marker 6 in the display indicates when the block distance detector is active. If the measured value skips (e.g. contamination of the antenna) erroneously to the block distance limit, the BD-DETECT should be deactivated.

8.6.15 Tank bottom tracing system

Description

- The BM 70 A/P firmware includes an additional function for measuring in tanks with poorly reflecting (i.e. relative permittivity $\epsilon_R \uparrow 3$) yet non-absorbing products. This function is designated "tank bottom tracing" (abbreviated to FTB) and utilizes the apparent shift of the tank bottom signal resulting from different microwave propagation rates in the air and in the tank product.
- It is necessary that the tank bottom is reflecting. Therefore this method is not applicable e.g. in tanks with a conical bottom.
- This requires that the relative permittivity ϵ_R of the tank product be as exact as possible. (This parameter can also be determined by a KROHNE Service technician from the recording of a tank filling or draining operation with the user program (see Sect. 8.12). The level in the tank should in this case change over the largest possible range.)
- When measurements are taken with activated FTB, an expectancy range for the measured value is determined on the basis of the shifted tank bottom signal, and inaccuracy of the ϵ_R value of $\pm 10\%$ is taken into consideration. If no evaluable measuring signal is obtained within this range, a substitute measured value is calculated direct from the tank bottom signal. This feature of the FTB even allows measurement in tanks without a direct useful signal, provided the tank bottom remains visible for the microwaves through the product.
- Since the exact position of the tank bottom must be known for this process, it is advisable when using the FTB to determine the tank height automatically with a completely empty tank, using Fct. 3.5.1, see Sect. 8.6.11.
- It needs to be borne in mind that, when measuring with the substitute measured value determined by way of the tank bottom signal, measuring accuracy will decrease by the factor $(\sqrt{\epsilon_R} - 1)$! For a ϵ_R of 2.25, accuracy decreases by one-half, i.e. the possible deviation will double; if ϵ_R is only 1.56, accuracy decreases to one-quarter.
- With **BM 70 P**: when the (Partical) tank bottom tracing system is used, the maximum measuring range is approx. 10% smaller, i.e. **max. tank height = 31.5 m !**

The tank bottom tracing system is operated by way of Fct. 3.5.7 and Fct. 3.5.8.

Fct. 3.5.7 FUNCT. FTB

The tank bottom tracing system is activated under this function:

- OFF
The FTB is deactivated; the device operates in the standard mode.
- PARTIAL
When this option has been selected, the tank bottom tracing system is activated only in the vicinity of the tank bottom, i.e. at low levels (max. 20% of the tank height but a minimum of 0.6 m). Given higher levels, the normal measuring method is used (reflection from the product surface). This method is sufficient for most applications with poorly reflecting products. The parameter EPSILON R (Fct. 3.5.8) must be as exact as possible.
- FULL (for BM 70 A only)
When this option is selected, the tank bottom tracing system is activated over the total measuring range (tank height). For tank heights above 16 m, however, measuring accuracy is additionally affected. The parameter EPSILON R (Fct. 3.5.8) must be as exact as possible.

Fct. 3.5.8 EPSILON R

Use this function to enter the relative permittivity.

- Allowable input range: 1.1000 - 8.0000
- Default: 2.0000

Enter the figure of 2.0000 if the relative permittivity is not known, as numerous products have a ϵ_R value ≈ 2 . However, expect reduced measuring accuracy and/or skipping of the measured value on changeover from tank bottom tracing to the normal measuring mode (= evaluation of reflection from the product surface), see following diagram:

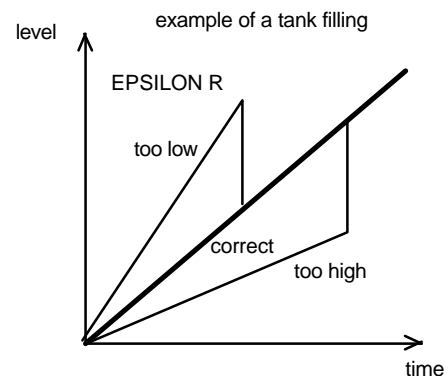

8.6.16 Tank type, movement of product surface

For optimum results, data acquisition and evaluation must be matched to typical tank characteristics: movement of the product surface, rapid or slow changes in the product level, agitators, etc.

Fct. 3.5.9 TANKTYPE

- **STORAGE T.**
Storage tank, still surface, slow rate of change in level
- **PROC.TANK**
Process tank, slight surface movement, rapid rate of change in level
- **AGITATOR** (for BM 70 A only)
Process tank with agitator, turbulent product surface

It is normally not critical if the tank type is set one step out. However, "AGITATOR" should not be set for a storage tank, and "STORAGE T." should not be set when an agitator is fitted.

It is possible, for instance, that the measured value will change in small steps rather than linearly or will "freeze" at times when the setting is grossly incorrect.

8.6.17 Switching output

The functions for the switching output can be applied to:

- a) the additional switching output in the Version "Ex-e or Ex-i current output HART[®]", or
- b) the current output if Fct. 3.3.1 FUNCTION I is set to "SW.OUTP."

Fct. 3.6.1. FUNCTION S

Use this function to select the measured variable.

- OFF (= deactivated; Fct. 3.6.2, 3.6.3 and 3.6.4 are no longer selectable, i.e. they are skipped over).
 - LEVEL
 - DISTANCE
 - CONVERSION
 - REFLECTION
 - ERROR OPEN (default)
 - ERROR CLOSED
- (Explanatory notes: see Table overleaf)

Fct. 3.6.2. TYPE S

- This function is not shown (is skipped over) when OFF or ERROR OPEN or ERROR CLOSED is set under Fct. 3.6.1. Not significant in this case!
- Use this function to set the type of switching output:
HIGH (= contact closes when **upper limit** of threshold + hysteresis / 2) exceeded
LOW (= contact closes when **lower limit** of threshold - hysteresis / 2) exceeded.

Fct. 3.6.3 THRESHOLD

- This function is not shown (is skipped over) when OFF, ERROR OPEN or ERROR CLOSED is set under Fct. 3.6.1. Not significant in this case!
- Use this function to define the threshold (limit value).
- Setting of LEVEL or DISTANCE under Fct. 3.6.1:
Unit same as for Fct. 3.1.1 TANKHEIGHT. If a reference or tank bottom offset is set, this must be taken into consideration!
- Setting: CONVERSION under Fct. 3.6.1:
Unit same as in Fct. 3.2.3 UNIT.CONV.
- Setting: REFLECTION under Fct. 3.6.1:
Setting range : 0...100.

Fct. 3.6.4 HYSTERESIS

- This function is not shown (is skipped over) when OFF, ERROR OPEN or ERROR CLOSED is set under Fct. 3.6.1. Not significant in this case!
- Use this function to define the hysteresis.
- Setting: LEVEL or DISTANCE under Fct. 3.6.1:
Setting range and unit same as for Fct. 3.1.1 TANKHEIGHT.
- Setting CONVERSION under Fct. 3.6.1:
Unit same as in Fct. 3.2.3 UNIT.CONV.
- Setting REFLECTION under Fct. 3.6.1:
Setting range: 0...100.

Examples of application and setting

see Sect. 8.5

Switching output characteristics

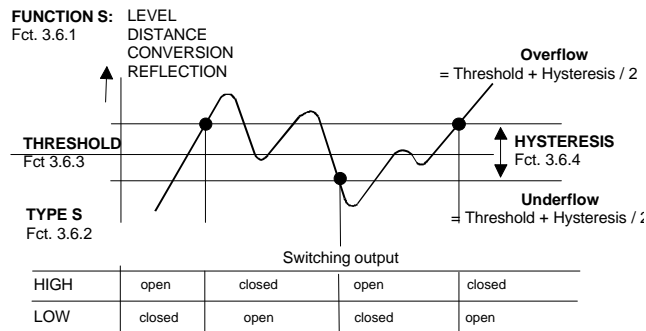

Sw.output application Examples see Sect. 8.5	Switching function settable by way of ...		Further parameters settable via ...	
	Fct. 3.6.1 <i>FUNCTION S</i>	Fct. 3.6.2 <i>TYPE S</i>	Fct. 3.6.3 <i>THRESHOLD</i>	Fct. 3.6.4 <i>HYSTERESIS</i>
Error message				
Contact opens when error occurs	ERROR OPEN	no *	no *	no*
Contact closes when error occurs	ERROR CLOSED	no *	no *	no*
Limit value, level				
- Contact closes when upper limit exceeded	LEVEL	HIGH	yes	yes
- Contact closes when lower limit exceeded	LEVEL	LOW	yes	yes
Limit value, distance				
- Contact closes when upper limit exceeded	DISTANCE	HIGH	yes	yes
- Contact closes when lower limit exceeded	DISTANCE	LOW	yes	yes
Limit value, conversion				
- Contact closes when upper limit exceeded	CONVERSION	HIGH	yes	yes
- Contact closes when lower limit exceeded	CONVERSION	LOW	yes	yes
Limit value, reflection				
- Contact closes when upper limit exceeded	REFLECTION	HIGH	yes	yes
- Contact closes when lower limit exceeded	REFLECTION	LOW	yes	yes
e.g. operation indicator				
Contact closed when supply power applied and open at power fail	OFF	no *	no *	no *

* Setting has no effect on the function of the switching output!

Overflow =
Measured value **higher than** limit value
(= threshold plus hysteresis / 2)

Underflow =
Measured value **lower than** limit value
(= threshold minus hysteresis / 2)

8.7 Functional checks

8.7.1 main menu 2.0 Test functions

Function (Fct.)	Input range	Description
2.0 TEST		
2.1.0 HARDWARE		
2.1.1 MASTER	Special function	Test of master hardware.
2.1.2 DISPLAY	Special function	Test of display hardware.
2.1.3 STATUS	Select Module DIS Module MW	Display of ID Number and status bytes.
2.2.0 CUR.OUTP.I		
2.2.1 VALUE I	Display of value	Display of actual value of the current output.
2.2.2 TEST I	Options 2 mA 4 mA 6 mA 8 mA 10 mA 12 mA 14 mA 16 mA 18 mA 20 mA 22 mA	Output of selected value to the current output. NOTE !!! With safety inquiry because current output is accessed direct !!! (Exi = min. 3.6 mA)
2.3.0 SW.OUTP.		
2.3.1 TEST S	Options OPEN CLOSED	Switches the switching contact on/off. NOTE !!! With safety inquiry because current output is accessed direct !!!
2.4.0 FIRMWARE		
2.4.1 MASTER	Display	Display of master firmware version.
2.4.2 DISPLAY	Display	Display of master firmware version.

8.7.2 Hardware test

Testing of the BM 70 A/P hardware can be initiated as required with these functions when the device is operating. When an error is established, a message appears in the display (see Sect. 8.8). This hardware test is carried out automatically every time the BM 70 A/P is started up.

Fct. 2.1.1 MASTER

- Select Function 2.1.1, as described in Sect. 8.2 and 8.3.
- "TEST" is shown in the display during the automatic test, followed by "READY" on completion of the test.
- During the test the current output holds the last measured value; digital Communication is not possible during that time.

Fct. 2.1.2. DISPLAY

- Select Function 2.1.2, as described in Sect. 8.2 and 8.3.
- Press the → key; all segments in the display are switched on.
- Press ↑ key; all segments are switched off.
- This procedure (switching on/off) can be repeated any number of times with the ↑ key.
- Press the ↓ key to terminate the test.

Fct. 2.1.3 STATUS

After selecting "Module DIS" or "Module MW" after pressing the ↓ key in each case an Identity Number and an 8-digit binary number are displayed. If an undefined error occurs, please inform KROHNE Service of these values. Terminate the test by pressing the ↓ key twice.

8.7.3 Test of current output

Fct. 2.2.1 VALUE I

- Select Function 2.2.1, as described in Sect. 8.2 and 8.3.
- Press → key to display the actual value of the current output (terminals 31 and 32) in "mA".
- Terminate test by pressing the ↓ key.

Fct. 2.2.2 TEST I

- A millia mmeter should be connected to terminals 31 and 32 for this test, see Sect. 7.8
- Select Function 2.2.2, as described in Sect. 8.2 and 8.3.
- Press → key.
- Safety inquiry: SURE NO } Select with
SURE YES } ↑ key

After SURE YES, press the ↓ key for the 1st value in the following list to be present at the current output.

- Select current values with the ↑ key:

2 mA	14 mA
4 mA	16 mA
6 mA	18 mA
8 mA	20 mA
10 mA	22 mA
12 mA	

- The connected millia mmeter indicates the selected current value.
- For instruments with Ex-i current output: in the 2 mA setting the minimum current of 3.6 mA is output.
- Terminate the test by pressing the ↓ key, and the actual measured value is again present at the current output.

8.7.4 Test of switching output

Fct. 2.3.1 TEST S

- In this test, the switching contact (terminals 41 and 42) can be closed or opened.
- Select Function 2.3.1 as described in Sect. 8.2 and 8.3.
- Press the → key.
- Safety inquiry: SURE NO } Select with ↑
SURE YES } key
- After SURE YES, press ↓ key.
- Displayed: OPEN = switching contact is open.
- Press the ↑ key.
- Displayed: CLOSED = switching contact is closed.
- Terminate the test by pressing the ↓ key, and the switching output will resume its normal operating condition.

8.7.5 Display of firmware version

Fct. 2.4.1 MASTER

This function MASTER shows the current main firmware version (e.g. V.3.00) in the configuration menu.

Fct. 2.4.2 DISPLAY

This function shows the current firmware version of the display part.

8.8 Pointers and error messages during measurement

8.8.1 Different kinds of messages

- a) **Pointers** (operating conditions) during measurement provided by 6 markers ▼ in the 3rd (bottom) line of the display, see Sect. 8.8.2.
- b) **Application errors**, indicating an application error condition in which no valid measured values are currently established. By changing the tank conditions (e.g. filling) this error can usually be remedied, see "Error list" in Sect. 8.8.3.
- c) **Minor errors**, indicating the failure of functions that usually do not affect measurement, see "Error List" in Sect. 8.8.3.
- d) **Correctable errors**, which can be remedied by operator action (manual) at the BM 70 A/P, or possibly by KROHNE Service, see "Error List" in Sect. 8.8.3.
- e) **FATAL ERROR** renders operation of the BM 70 A/P impossible; occurs only when the device is switched on (powered) or after special test functions have been executed, when the self-test identifies an error in the electronics of the BM 70 A/P, see "Error List" in Sect. 8.8.3.

8.8.2 Pointers provided by 6 markers ▼ during measurement

Marker	Cause	Explanation
1	No current measured value	The device is currently searching for a new measured value in which the "measuring window" is opened. If the search for a plausible level fails, "SIGNAL DOWN" appears in the Error List, see Sect. 8.8.3.
2	Signal too strong	Mean of reflected microwaves is very high. Gain is automatically stepped down. Brief showing of this marker, e.g. while tank is being filled or drained, is insignificant. In conjunction with stilling wells, the marker can also show for a longer time.
3	Poor spectrum	Number of acceptable spectra is too low. Brief showing of this marker has no significance. If permanently on, this may result in uncertain (incorrect) measured values or the error message "NO M.VALUE", see Sect. 8.8.3.
4	No measured value as yet	Evaluable measured values not available after the device has been started up. Measured value automatically set to the level of the tank bottom. This marker disappears when the first valid measured value is obtained.
5	Tank bottom	In tanks with dished bottom, for example, the measuring signal can "disappear" if measurements are carried out near the bottom (within a range of 10% of the tank height, see Fct. 3.1.1, but minimum of 20 cm or 8" and maximum of 60 cm or 24"). The measured value is then automatically set to the level of the tank bottom.
6	Measurement frozen	The digital input is active (voltage at terminals 81,82) or the device is in the range of the block distance detector (see Sect. 8.6.12). Measurement is thus suspended (frozen); last measured values present at the outputs and in the display.

8.8.3. Error messages and their representation in display and at outputs

The following list gives all error messages that can occur:

Error messages		Description of error	To correct device fault	Output of errors via display and outputs, depending on setting					
Type	Text In 2nd line of display			Display		Current output I		Switching output S	
(Sect. 8.8.1)				ERROR MSG. Fct. 3.2.4		RANGE I Fct. 3.3.2		FUNCTION S Fct. 3.6.1	
				YES	NO	4-20/2=E 4-20/22=E	4-20	ERROR OPEN ERROR CLOSED	OFF LEVEL DISTANCE CONVERSION REFLECTION
b)	NO M.VALUE	Evaluable measuring signals not available	If this error is displayed for a lengthy period, this could mean application-induced errors. Check the application conditions!	yes	no	yes	no	yes	no
c)	LINE INTERRUPT	Power failure detected	During restart following a brief power failure. Display vanishes as soon as a valid measured value is again present.	yes	no	yes	no	yes	no
	SWEEP LOW	Restricted functioning of microwave board	Measurement continued, possibly with reduced accuracy. If error present for longer time or "VCO SWEEP" error (see below) occurs, consult KROHNE Service!	yes	no	no	no	no	no
	WATCH DOG	Processor monitoring	If error present for longer time, this means an error on the CPU board; needs to be replaced by KROHNE Service!	yes	no	no	no	no	no
	SPECT. ERR.	Empty spectrum faulty	The current empty-tank spectrum does not match the changed operating parameters. Remedy: record new empty spectrum (Fct 3.5.2).	yes	no	no	no	no	no
	NO DISP.	Configuration faulty	Reset parameters for the displayed units (Fct. 3.2.2, 3.2.3).	yes	yes	no	no	no	no
	CAL. DATA	EEPROM error: current output calibration data	Calibration data of the current output need to be checked by KROHNE Service and reset if necessary.	yes	no	yes (22 mA)	no	yes	no
	CONFIG. ERR	EEPROM error: parameters faulty	Check all operating parameters and reset if necessary. If error persists: EEPROM defective. Needs to be replaced by KROHNE Service!	yes	yes	yes (22 mA)	no	yes	yes
d)	EEPROM ERR.	EEPROM defective	EEPROM defective. Needs to be replaced by KROHNE Service!	yes	no	yes	no	yes	no
	ADC ERR.	Analog/digital converter defective	CPU board defective. Needs to be replaced by KROHNE Service!	yes	no	yes	no	yes	no
	INTEGR.	Integrator defective	CPU board defective. Needs to be replaced by KROHNE Service!	yes	no	yes	no	yes	no
	SIGNAL DOWN	Measuring signal too weak for evaluation	No measuring signal, usually caused by a defect in the electronics.	yes	no	yes	no	yes	no
	VCO RISE	Fault on microwave board	Microwave board defective. Needs to be replaced by KROHNE Service!	yes	no	yes	no	yes	no
	VCO SWEEP	Fault on microwave board	Microwave board defective. Needs to be replaced by KROHNE Service!	yes	no	yes	no	yes	no
e)	FATAL ERROR	CPU board defective	After a device start-up. If still possible, invoke Error List and note down any other errors. Consult KROHNE Service!	yes	yes	no	no	no	no

8.8.4 Error display during measurement

In the setting level under Fct. 3.2.4 ERROR MSG. (error messages), it is possible to select whether errors are to be displayed during measurement. When YES set: "error message(s)" are displayed automatically to alternate with the measured value. The errors will continue to be displayed until their cause has been eliminated.

8.8.5 Error list

All errors are stored in an Error List in the BM 70 A/P. The errors are retained in this list until: **1.** the cause(s) of the error(s) has been eliminated **and 2.** the error has been acknowledged. Errors that have been acknowledged but whose cause has not been eliminated are retained in the Error List.

To invoke the Error List, press keys $\downarrow \uparrow \rightarrow \rightarrow$. With \rightarrow you can page through the list. For further information on the Error List: see Sect. 8.3.

8.9 Messages on start-up

When the BM 70 A/P is powered it will take about 1 minute before the first measured value is displayed (see also Sect. 5.6). During this time the following flashing messages appear in sequence in the display:
STARTUP - READY - START.

After a short line failure (lasting up to several minutes) it is possible that "LINE INTERRUPT" will be displayed. In such a case, measurement is continued subsequently taking into account the history prior to the interruption.

8.10 Faults and symptoms during start-up and measurement

- You will be able to eliminate most of the faults and symptoms likely to occur with the BM 70 A/P by consulting the following chart.
- For easy reference, faults and symptoms are divided into the following groups:
 - Group D Display
 - Group A Signal output
 - Group DA Display and signal output
 - Group M markers 1 - 6 ▼ in the display
 - Group S Switching output
- Please go through these charts before contacting KROHNE Service. Thank you!

Group D Display			
No.	Fault / Symptom	Cause	Corrective action
D1	Display totally "dead".	Power source switched off.	Switch on power source.
		Primary fuse defective.	Change primary fuse as described in Sect. 9.3.
D2	Display flashes "FATAL ERROR" shortly after power has been switched on.	BM 70 A/P is defective.	Replace BM 70 A/P signal converter (instrument head) as described in Sect.7.3 .
D3	Display flashes "MIN VALUE" or "MAX VALUE" when numerical values are being set.	The set numerical value is outside the acceptable setting range.	Note MIN. or MAX.VALUE displayed and set higher or lower numerical value.
D4	Display shows "START".	Device carries out a hot start after a parameter change.	Wait until measured value appears.
D5	Display flashes "SPECT.ERR.".	Newly set operating parameters do not tally with the stored spectrum when e.g. the tank height (Fct. 3.1.1) and/or the antenna extension (Fct. 3.1.4) have been changed.	Record new empty spectrum as described in Sect. 8.6.12 (Fct. 3.5.2).
D6	Display indicates error message alternating with the measured value.	An error has occurred.	Note down error messages, eliminate as described in Sect. 8.8

Group A Signal output			
No.	Fault / Symptom	Cause	Corrective action
A1	Receiver instruments connected to current output indicate "zero".	Polarity (connection) of receiver instruments is incorrect.	Connect up properly as described in Sect. 7.8.
		BM 70 A/P current output board or connected receiver instruments defective.	Test current output as described in Sect. 8.7.3. - All tests OK: Check receiver instruments and replace if necessary. - Test reveals faults: current output board defective; consult KROHNE Service or replace BM 70 A/P signal converter (see Sect. 7.3).
		"OFF" (= current output deactivated) is set under current output I, Fct. 3.3.1, "FUNCTION I".	Depending on the application, set LEVEL, CONVERSION, DISTANCE or REFLECTION under Fct. 3.3.1, see Sect. 8.6.8
A2	2 or 22 mA present at the current output.	An error has occurred.	Invoke display of error list, see Sect. 8.8. For cause and elimination, see Sect. 8.8. If error message not to be displayed via the current output, set 4-20 mA without error message, as described in Sect. 8.6.8 (Fct. 3.3.2).

A3	The measured value at the current output is incorrect, but the measured value in the BM 70 A/P display is correct.	Settings of the current output are incorrect.	Set current output correctly as described in Sect. 8.6.8 (Fct.3.3.1 - 3.3.4).
A4	Data Communication via the digital interface not functioning.	Communication interface set incorrectly.	Set Communication interface, Sect. 8.6.9, correctly (Fct.3.3.5 - 3.3.7).
		The computer system for Communication with the BM 70 A/P is incorrectly configured.	Check computer system.
		Incorrect connection to the interface.	Check connection.
		Communication interface is defective.	Consult KROHNE Service or replace BM 70 A/P instrument head as described in Sect. 7.3.

Group DA Display and signal output

No.	Fault / Symptom	Cause	Corrective action
DA1	Display and current output supply incorrect measured values.	Display and current output are set incorrectly.	Set display (Fct. 3.2.1 -3.2.4) and current output (Fct. 3.3.1 - 3.3.4) correctly, as described in Sect. 8.6.7 and 8.6.8.
		An error has occurred. Display and current output are, however, not set for error messages; markers 1-6 are perhaps ON.	Invoke Error List, see Sect. 8.8, also for cause and elimination. If (also) one or several markers ▼ are ON, see Sect. 8.8.2.
DA2	Display and current output supply a largely constant measuring error of approx. 19 cm.	Distance piece is provided but not configured correctly.	Set Fct. 3.1.5 DIST.PCE. (see Sect.8.6.4) to 120 mm when distance piece fitted, otherwise to 0 mm.
DA3	Display and current output supply a largely constant and large-size measuring error.	Tank height set incorrectly (level measurement).	Set Fct. 3.1.1 TANKHEIGHT (see Sect.8.6.2) correctly; if possible, use automatic tank height determination, Fct. 3.5.1 (see Sect. 8.6.11)
		Reference offset (distance measurement) or tank bottom offset (level measurement) incorrectly programmed.	Set offset values correctly, Fct. 3.1.7 - 3.1.8 (see Sect. 8.6.6).
DA4	Measuring error in the stilling well increases steadily in step with increasing distance.	Stilling well not included in the configuration.	Set Fct. 3.1.6 STILLWELL correctly (see Sect. 8.6.5).
DA5	major measuring errors (> 3 cm) with Wave-Stick in the close range (up to approx. 1 m distance)	Antenna type is incorrectly set.	Set Fct. 3.1.3. ANTENNA to "WAVE-STICK" (see Sect. 8.6.3)
DA6	When the empty tank is being filled, the measured value initially stays at "zero" and then, at 20...100 cm level, suddenly skips to the correct value.	The BM 70 A/P is receiving an additional signal from the tank bottom.	Activate "tank bottom tracking system", see Sect. 8.6.15 (Fct. 3.5.7 - 3.5.8)
DA7	Display and signal output do not respond to changes in level.	Digital input is activated, marker 6 ▼ is ON, measurement is suspended (frozen).	Deactivate the digital input, see Sect. 4.8.
		Device is within block distance detection range, marker 6 ▼ is ON; level too high or antenna contaminated.	Reduce level and/or clean antenna, or deactivate Fct. 3.5.6 BD-DETECT (see Sect. 8.6.14) or reduce size of Fct. 3.1.2 BLOCKDIST. (see Sect. 8.6.3).
		Foaming in vessel, inadequate reflectivity of the tank product, ϵ_R too small; additionally, markers 1+3 ▼ may be ON.	On tall storage tanks, mount the BM 70 A/P farther away from the tank wall. Select distance as recommended in Sect. 6.1.2.
DA8	Display and signal output indicate "zero" measured value, marker 5 ▼ is ON.	Tank with dished bottom: tank is more than 20% full, the BM 70 A/P is mistakenly located in the "tank bottom detection" range.	Drain tank or switch the BM 70 A/P off for a short while. If unsuccessful, please consult KROHNE Service.
DA9	Display and signal output indicate max. level but tank is empty.	Tank with dished bottom: the BM 70 A/P has stored an incorrect or incomplete empty spectrum.	Record new empty tank spectrum, see Sect. 8.6.12 (Fct. 3.5.2), or enlarge block distance (Fct. 3.1.2) as described in Sect. 8.6.3.

Group DA Display and signal output			
No.	Fault / Symptom	Cause	Corrective action
DA10	Display and signal output frequently indicate the maximum level.	Excessive amounts of vapour, condensate or dust in the tank, or heavy contamination (deposits thicker than approx. 3 - 7 mm or 0.1" - 0.3") on the antenna.	Clean antenna (install cleaning device if necessary). If unsuccessful, enlarge BLOCKDIST. under Fct. 3.1.2 (see Sect. 8.6.3) or deactivate Fct. 3.5.6 BD-DETECT (see Sect.8.6.14).
		Antenna cleaning operations cause strong reflections.	Activate digital input during cleaning (marker 6 ▼ is ON), measurement suspended (frozen), see Sect. 4.8.
DA11	Display and signal output indicate sizeable step changes in the direction of the maximum (possibly also minimum) level.	Storage tank: BM 70 A/P mounted centrally or on dome (manhole cover).	Change position of the BM 70 A/P. For recommended distance from tank wall, see Sect. 6.1.2, and note installation conditions in Sect. 6.1.3! Or activate "multiple reflection identifier" under Fct. 3.5.5, see Sect. 8.6.14.
		Process tank with extremely turbulent product surface.	Switch on tank type AGITATOR under Fct. 3.5.9, see Sect. 8.6.16.
DA12	Display and signal output indicate step changes: during filling → upwards during draining → downwards	Storage tank, smooth surface, steady filling or draining procedures, incorrect tank type set.	Set correct tank type (STORAGE TANK) under Fct. 3.5.9, see Sect. 8.6.16.
DA13	Signal output (recorder) shows sinusoidal variations about the actually measured value (deviation: up to ± 2 cm) in the upper part of the tank (approx 2 m).	This has physical reasons and occurs mostly with slow changes in level when sources of interference are located in the upper part of the tank.	Avoid all sources of interference in the upper part of the tank. A bigger antenna might help to solve the problem.
DA14	Display and signal output indicate constant measured values, although the level changes.	Fixed tank internals unfavourably positioned, thus permanently simulating a constant level to the BM 70 A/P. No empty spectrum recorded and/or measurements carried out without empty spectrum.	Activate the empty spectrum under Fct. 3.5.2 if measurements carried out without empty spectrum. If empty spectrum not recorded, record under Fct. 3.5.2, see Sect. 8.6.12.
		Digital input is activated, marker 6 ▼ is ON, measurement is suspended (frozen).	Deactivate the digital input, see Sect. 4.8
DA15	Display and signal output indicate measured values at the level of the agitator blades.	Tank with "difficult" agitator blades.	Record new empty spectrum with "MAX. VALUES" under Fct. 3.5.2. Or change position of the BM 70 A/P on the tank. Note conditions described in Sect. 6.1.2.
DA16	Display and/or signal output indicate incorrect conversion values, but level indication is correct.	Conversion table set incorrectly.	Reset conversion table with the PC-CAT program.
DA17	Display and signal output go suddenly to "zero" or block distance limit when tank continuously topped up.	Level located in range of block distance in front of antenna, see Fct. 3.1.2 in Sect. 8.6.3.	Avoid this operating condition or, if empty spectrum (Fct. 3.5.2) is sufficiently good, reduce block distance (Fct. 3.1.2) as described in Sect.8.6.3.

Group M markers 1-6 in display			
No.	Fault / Symptom	Cause	Corrective action
M1	markers 1-5 ▼ (one or several) ON.	Reference(s) to possible faulty measurements.	See Sect. 8.8 for significance of markers and elimination of possible faults.
M2	marker 2 ▼ ON for long periods or permanently.	Note: very strong reflection signal (e.g. measurement in the stilling well).	Not important if measured value is correct.
M3	marker 6 ▼ ON.	Digital input is activated, measurements suspended (frozen).	Deactivate digital input, see Sect. 4.8.
		Device located in block distance detection range.	Check conditions for block distance detection, see Sect. 8.6.14.
M4	markers 3 and 4 ▼ ON. Level indicator is "zero".	This is a status display and not an error. This usually occurs on tanks with dish bottom, when the tank is empty, after the BM 70 A/P has been switched on or after a new empty spectrum has been recorded.	Fill tank!

Group S		Switching output	
No.	Fault / Symptom	Cause	Corrective action
S1	Switching output does not operate at the desired limit value (threshold) or does so in the wrong mode (opens/closes).	Setting of switching function is incorrect.	Set switching output correctly as described in Sect. 8.6.17 (Fct. 3.6.1 - 3.6.4).
S2	Switching output does not operate.	Switching output defective.	Check switching output as described in Sect. 8.7.4: - Test OK: check setting and receiver instruments. - Test reveals faults: switching output defective. Consult KROHNE Service or replace BM 70 A/P signal converter as described in Sect. 7.3.

8.11 Calculation of the measured value

The following describes how the individual items of information are calculated from the measured distance:

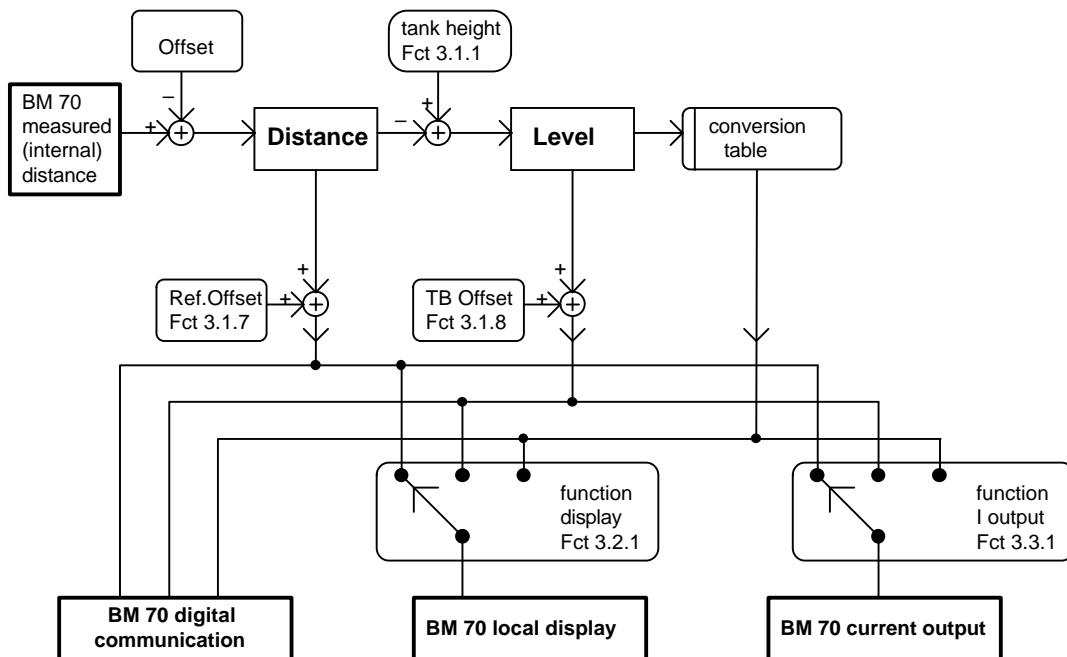

The measured primary distance is corrected by the offset and consequently standardized to the reference point (= flange). The level is calculated as the difference between tank height and distance. Optionally, distance, level or a converted function can be output to the signal output and the local display. All items of information can be accessed via the digital Communication. In addition, the measured value can be shifted by a reference offset (reference point for distance not equal to flange) or by a tank bottom offset (reference point for level not equal to tank bottom).

8.12 User program PC-CAT for Windows

Our instruments of the BM 70 product line are easy to install. To facilitate configuration, each unit is supplied with the intuitive and time-tried software, PC-CAT for Windows.

PC-CAT provides a number of useful features including:

- Quick on-site configuration
- Print-out of configuration protocol
- Simple conversion, volume or correction tables
- Check routine to monitor functionality of the instrument
- Monitoring and recording of the radar signal during operation
- Trend and evaluation of the signal during operation

PC-CAT works on all IBM-compatible PC's using Windows 9x or NT.

PC-CAT Version 4.00 and higher can communicate with all current KROHNE level radar gauges including BM 70 A/P, BM 700, BM 702 versions, also with HART[®] protocol and RS 485. The PC-CAT kit includes a PC adapter for current output. The adapter can be connected to the PC's standard RS 232 interface.

PC-CAT allows convenient remote control of all functions of the signal converter. The vessel can be shown in schematic form together with the associated measured values and the measured spectrum. A trend graph of the output signal and threshold signal strength is also provided. All relevant instrument data can be recorded in the form of a data set small enough to be stored on a floppy disk or transferred electronically. Stored data can also be used for configuring other units of the BM 70 product line.

PC-CAT files can later be used to analyse the performance of the level gauge. All graphs and screens can be exported a word processing systems or other programs.

The customer's PC containing PC-CAT is connected to the current output via the supplied Pcadapter Pcadapter, max. distance from the level gauge: 1000 m or 3300 ft. The PC adapter has no effect on in-line instruments such as millimeters, recorders, etc., connected to the current output.

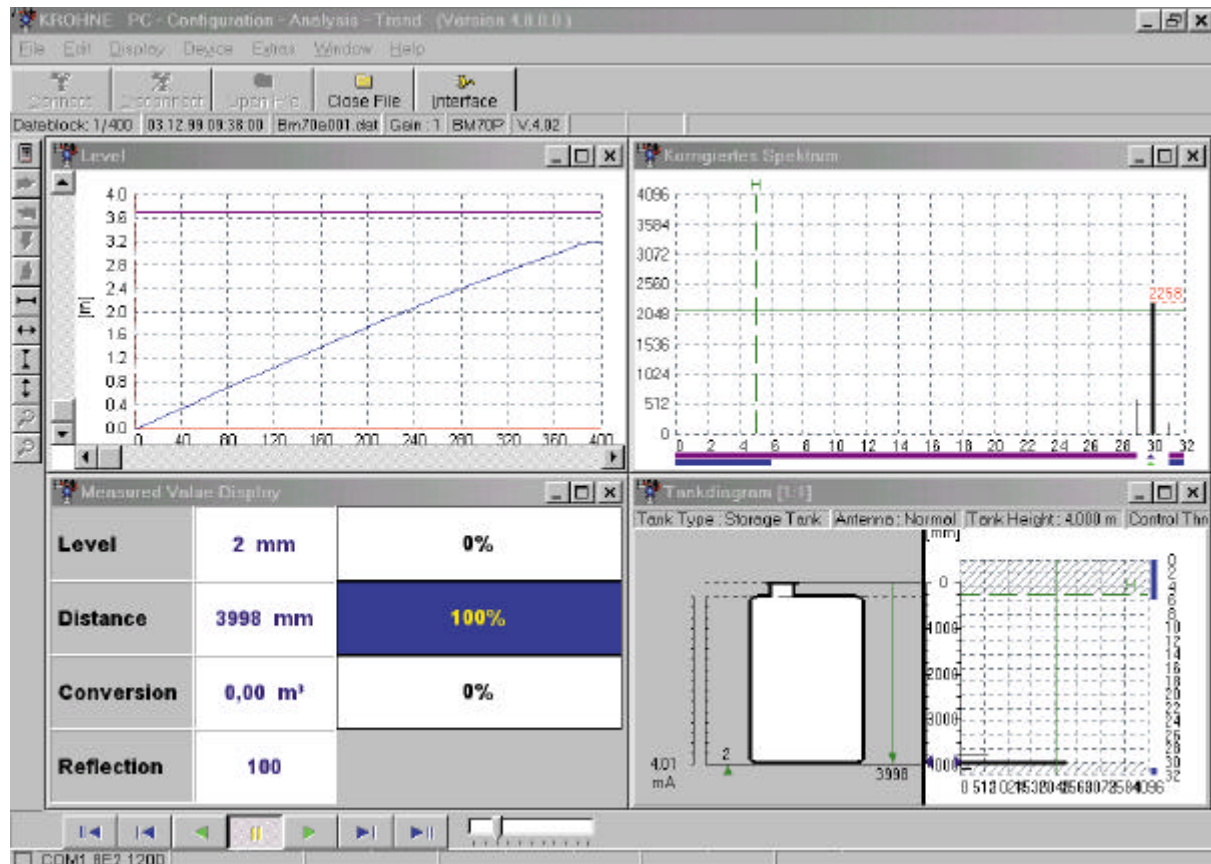

9 Power supply

9.1 Options, technical data

A choice is offered of 2 supply power versions:

Version	Voltage U	Tolerance	= voltage range	Frequency	Power (typical) *	max. ripple / harmonics
24V DCAC	24 V DC	-25% +30%	18-31.2 V	-	7.5 - 10 W	within limits of tolerance
	24 V AC	-25% +10%	18-26.4 V	45-66 Hz	10 VA	10%
115/230V AC	115 V AC	-25% +10%	85-127 V	45-66 Hz	12 VA	10%
	230 V AC	-25% +10%	170-254 V	45-66 Hz	12 VA	10%

* Hazardous-duty limit: 20W / 40 VA

9.2 Fuses

Device-internal fuses for power:	24 V DCAC*	T 1.25 A
	115 V AC**	T 315 mA
	230 V AC**	T 160 mA

*: Terminals 1 and 2 are both fuse-protected.

**: Only connection L (for TN system) is fuse-protected;
optionally also both connections N and L (for IT system), see Sect. 9.3.

Location of fuses on the "line" board and replacement of fuses: see Sect. 9.3.

In accordance with operative regulations, it may be necessary to provide additional fuse protection when installing the system.

Recommended line fuse protection:	24 V DCAC	min. T 2 A
	115 V AC	min. T 0.5 A
	230 V AC	min. T 0.25 A

9.3 Changeover of operating voltage and replacement of fuses

Always switch off power source before commencing work!

Hazardous-duty systems:

Before opening the "flameproof enclosure" (large cover on the signal converter) in the hazardous area, make absolutely certain that there is no explosion hazard. Allow the prescribed waiting time of 10 minutes to elapse first!

1. Unscrew sunshade **SD**, if fitted.
2. Detach safety lock **SV** using Allen key (size 4 mm).
3. Remove cover **DE** from the electronic compartment (flameproof enclosure) with the supplied special wrench.

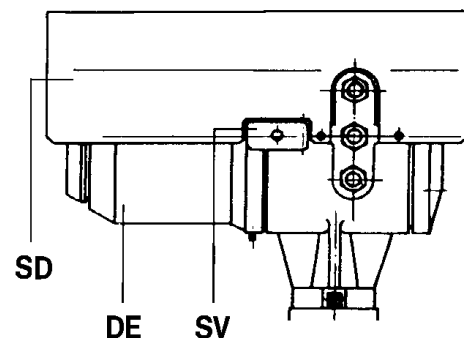

4.1 Replacement of power fuse(s)

Location of fuses: see drawings below. Use only the specified types.

4.2 Changeover of operating voltage (AC Version only)

Through a different orientation of the voltage selector switch on the "line" board you can switch over between 115 V AC (85-127V) and 230 V AC (170-254V). For this purpose, pull the plug next to the fuse holders up and out (see drawing below), turn it 180° and plug it back into the holder. Also change the two fuses F2 and F3 to suit the selected voltage.

Do not forget to alter the voltage information on the signal converter nameplate and in the terminal compartment!

4.3 Changeover between 1 fuse (TN system) and 2 fuses (IT system) (AC-Version only)

Plug the blue wire on the "line" board into the desired position "TN" or "IT". Do not forget to alter the information TN or IT on the signal converter nameplate ("field power").

5. Reassemble in reverse order, Points 3-1.

Important: Ensure that the screw thread of cover DE on the electronic compartment is well greased at all times.

Power supply unit 115/230 V AC

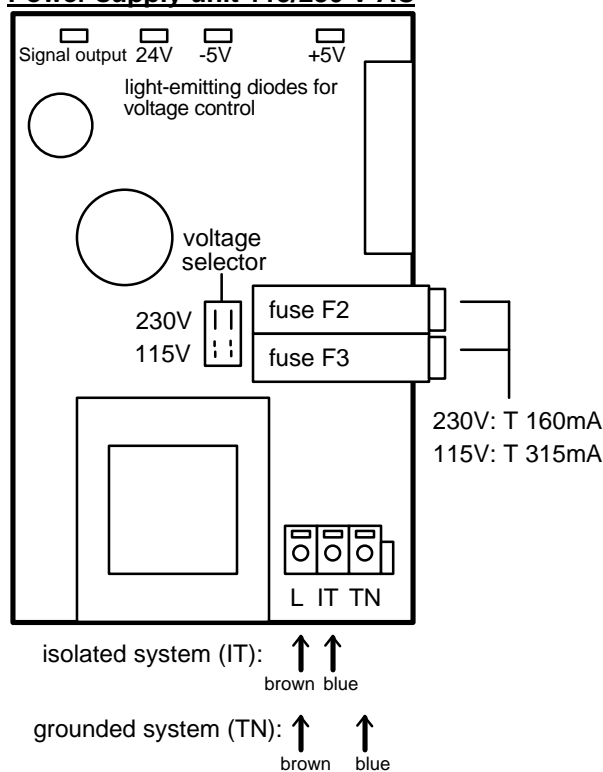

Power supply unit 24 V DCAC

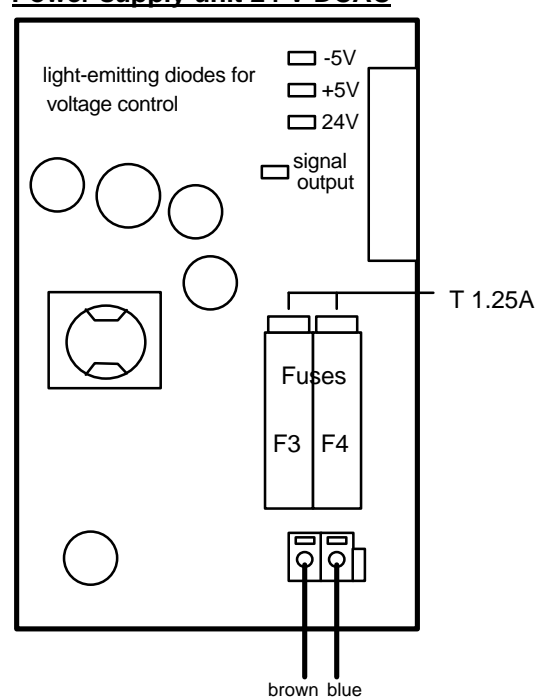

9.4 Advice on safety

Insulation rating

The insulation of type BM 70 A/P level gauges is rated in conformity with VDE 0110/01.89, equivalent to IEC 664, and takes into account the following ratings:

- Overvoltage category for the power line circuit: III
- Overvoltage category for the output circuit: II
- Insulation contamination level: 2 (inside the device)

Disconnecting device, miniature fuse

Type BM 70 A/P level gauges do not feature any device for switching or disconnection.

Class of protection

The BM 70 A/P level gauge is designed for Safety Class 1 in conformity with VDE 0106 Part 1.

24 V DCAC supply

When connected to a "**functional extra-low voltage with safety separation**" power source (SELV or PELV) in accordance with VDE 0100, Part 410 or equivalent (inter)national regulations, connection of a safety conductor (PE) is not required.

115/230 V AC supply

Connection to a power source with **dangerous contact voltage**: if due to protective measures in conformity with VDE 0100 a **safety conductor PE** is stipulated, it **must** be connected to the separate U-clamp terminal in the terminal compartment of the signal converter.

HAZARDOUS-DUTY SYSTEMS

- The incoming cables for **power supply** are **not of intrinsically safe design**, not even in the BM 70 A/P i version.
- **Electrical connection** to be in conformity with VDE 0165, Section 5.6, or equivalent national regulations.
- Before making the electrical connection, make sure all cables leading into the BM 70 A/P-Ex are **disconnected from supply!**
- When used in hazardous locations, the BM 70 A/P-Ex **must**, in conformity with VDE 0165, be incorporated in the **PA equipotential bonding system**, irrespective of the type of power supply. If the PA is connected via a separate conductor, this must be connected to the outer U-clamp terminal on the "neck" of the BM 70 A/P-Ex. Cancellation of equipotential bonding is only permitted when the BM 70 A/P-Ex is **disconnected from supply**.

10 Certificates and approvals

10.1 Hazardous-duty approvals

Country	Authority	Certificate No.	Class	Device type
Germany/Europe	PTB	PTB99 ATEX 2061X	EEx de IIC T6..T1 (Z.0)	BM 70
			EEx de [ia]/[ib] IIC/IIB T6..T3 (Z.0)	BM 70 i
USA	FM	J.I.3000813	I Div.1 Gr.B/C/D	BM 70
			II/III Div.1 Gr.E/F/G	BM 70
USA	FM	J.I.3006165	I/II/III Div.2 Gr. B/C/D/F/G	
			I Div.1 Gr.B/C/D	BM 70.i
			II/III Div.1 Gr.E/F/G	BM 70.i
			I Div.2 Gr. A/B/C/D	
			II/III Div.2 Gr. P/G	
Canada	CSA	in preparation		BM 70.
Japan	RIIS	in preparation		BM 70.

The texts of valid "Ex" certificates of conformity and type approvals are reprinted in the attached "Ex" documentation.

10.2 Other approvals and certificates

Type	Company	Date/Certificate No.
Radio approval	BZT	Vfg1117/1989; Vfg241/1995
Radio Licence	FCC	JH5BM70
Preliminary approval to German pressure vessel code DruckbehV/TRB511 (flange V 96)	RWTÜV	No. 5636602

10.3 Explosion proof acc. to ATEX

The instruments BM 70 A, BM 70 P and BM 700/702 are approved according to the new hazardous area directives **ATEX** 100a (certificate: PTB 99 ATEX 2061X).

Instruments were divided up to the following **Categories** according to the operating range:

Probability of hazardous atmosphere	Ex zone	Device in (G = gas/vapour/mist)
Always, long-term or frequent	Zone 0	Device category 1G
Occasional	Zone 1	Device category 2G
Not or seldom and then only short-term	Zone 2	Device category 3G

The marking of the BM 70 x instrument depends on the converter and the flange system:

	Converter with outputs in Ex-e	Converter with outputs in Ex-i
Flange system for zone 0 (1G)	1/2 G	1/2 G
Flange system for zone 1 (2G)	2 G	(1)2 G

Means:

1/2 G	Antenna system in zone 0 (1G), converter in zone 1 (2G)
2 G	Converter as well as antenna system only in zone 1 (2G)
(1)2 G	Converter and antenna system in zone 1 (2G), but intrinsically safe current loops can go to/through zone 0 (1G)

The available **flange systems** for BM 70 A, BM 70 P and BM 700/702 are:

Construction	Short term in ATEX certificate	Device category	Installation in Ex zone
Horn antenna or Wave-Guide (with Metaglass)	V96	1G ²⁾	Zone 0
Wave-Stick with flange plate and Metaglas	WS 1C ¹⁾	1G ²⁾	Zone 0
Wave-Stick with flange plate	WS 1B	2G	Zone 1
Wave-Stick without flange plate	WS 2A or 2B	2G	Zone 1
LP flange system (horn antenna/Wave-Guide)	Not in approval	Non-Ex	Non-Ex

Remarks:

1) For the Wave-Stick 1C (Zone 0) any electrostatic charging of the stick must be avoided in operation (otherwise only Zone 1).

2) Zone 0 is only defined for "**atmospheric conditions**". Therefore in the ATEX certificate the conditions T = -20...+60 °C and p = 0.8...1.1 bar are assigned to the 1G versions for installation in Zone 0. This is not new, but now explicitly mentioned in the type test.

10.4 Radio approval

Gazette 129, 20.11.1989

TeleCommunications

Decree 1117/1989

General licence No. 353 for radio transmitting and receiving installations

The installation and operation of the radio transmitting and receiving system "BM 70 Level Radar" and "BM 70-Ex Level Radar" manufactured by Firma KROHNE Messtechnik GmbH & Co. KG, 4100 Duisburg, for telecontrol purposes (level gauging in metal tanks) at a frequency in the 8.1 - 9.4 Ghz frequency range, is hereby authorized pursuant to §§ 1 and 2 of the law concerning teleCommunication systems as adopted in the official announcement dated 03.07.1989. The radio systems may only be operated inside totally enclosed metal tanks.

1. Other teleCommunication systems and teleCommunication equipment serving the public sector, including radio systems, must not suffer any interference.
2. Radio systems that are put onto the market under the above-mentioned type designations do not individually require special approval if they are electrically and mechanically consistent with the models examined and tested by the Central Approval Office for TeleCommunications (ZZF), and bear the following certification mark of the Deutsche Bundespost: "Postsignum Z G490353X" and the name of KROHNE Messtechnik GmbH & Co. KG, 4100 Duisburg, and the type designation "BM 70 Level Radar" or "BM 70-Ex Level Radar".
3. The identification mark must be embossed or engraved on the housing or on a plate made of metal or similarly strong material. The plate must be attached to the housing in such a way that it is impossible to remove or can only be removed by the use of force. *The identification mark must be visible at all times from the outside.*
4. The operator of such radio systems has no benefit of protection whatsoever against interference from other teleCommunication systems or teleCommunication equipment (e.g. including radio systems that are duly operated in the same frequency range).
5. The above-mentioned radio systems may not be linked to other teleCommunication systems or teleCommunication equipment without special approval from the Deutsche Bundespost.
6. This "general licence" can at any time be revoked in toto - or in isolated cases can also be revoked for individual radio systems by the relevant local licensing authority.

Additional notes for manufacturer and users

1. The manufacturer of these generally licensed radio systems has the responsibility towards the Deutsche Bundespost to ensure that a reprint of this "general licence" accompanies each and every instrument brought onto the market under the above-mentioned certification mark.
2. The licence to link these radio systems with other teleCommunication systems or teleCommunication equipment is governed by the respective requirements (provisions concerning private-sector cabled teleCommunication equipment, and the teleCommunication regulations). Information in this respect is available from the appropriate teleCommunication offices (acceptance and testing service).

281-3 A 3552-2/A

Bundesministerium für Post und Telekommunikation
1421

Gazette 23/95

Decree 241/1995

Extension of the general licence No. 353 for radio transmitting and receiving installations

To Gazette Decree 1117/1989, page 2066

The above-mentioned general licence for radio installations issued to the company of KROHNE Messtechnik GmbH & Co. KG, 47058 Duisburg, shall with immediate effect also include radio installations that operate at a frequency in the frequency range of 8.1 - 9.9 GHz, for the same purpose are placed by the company on the market and which are marked in accordance with the general licence. At the same time, the purpose **is extended to level measurements in concrete tanks having a minimum wall thickness of 19 cm.** The radio installations may only be **operated in fully enclosed tanks.**

314-1A 3552-2/A

10.5 CE Manufacturer's declaration

DECLARATION OF CONFORMITY

We, **KROHNE Messtechnik GmbH & Co.KG**
Ludwig - KROHNE - Straße
D - 47058 Duisburg

declare on our own responsibility that the products

- BM 70 A/P Level-Radar 24V DC/AC - Ex-e current output / RS 485
- BM 70 A/P Level-Radar 115/230V AC - Ex-e current output / RS 485

to which this declaration refers, are in conformity with the following standards:

- EN 50081 - 1 : 1993 - 3
- EN 50082 - 2 : 1995 - 3
- pr EN 50178 : 1994 - 8
- EN 61010 - 1 : 1993 - 4

in accordance with the provisions of Directives 89 / 336 / EEC und 73 / 23 / EEC.

Duisburg, 01.09.1997
(Place and date of issue)

(signed: Company management)

11 Order information

Technical information relevant to the order

BM 70 A/P Level-Radar

- ◆ Connecting flange: _____
- ◆ Flange and antenna material: ... _____
- ◆ Waveguide seal: Viton FFKM Kalrez2035 Other _____
- ◆ Antenna type: Type 4 (200 mm) Type 3 (140 mm)
..... Type 1 (74 mm) Type 2 (100 mm) [for stilling well dia.: _]
..... Wave-Stick Wave-Guide (length: _____)
- ◆ Antenna extension: _____
- ◆ Power supply: 24V DCAC 200-240V AC 100-120V AC
- ◆ Signal output: Current output: active (Ex-e) Ex-i passive
alternatively: Digital: RS 485 Bus: _____
- ◆ Explosion protection none Zone 0 Zone 1

Special items

- Additional calibration (BM 70 A Precision)
- High-precision version (BM 70 P)
- 90° Antenna extension S-shaped antenna extension
- Purge connection Antenna heating
- Others: _____

12 External standards, codes and directives

DIN V 19259: 1996-10. Documentation of devices, Data types with classification scheme for measuring equipment with analog or digital output for industrial process measurement [in German]

VDI/VDE 3519 (part 2): 1994-12. Level measurement of liquids and solids (bulk solids) [in German]

DIN VDE 0165: 1991-02. Installation of electrical apparatus in hazardous areas [in German]

DIN EN 50014: 2000-02. Electrical apparatus for potentially explosive atmospheres, General requirements

DIN EN 50018: 1995-03. Electrical apparatus for potentially explosive atmospheres, Flameproof enclosure "d"

DIN EN 50019: 1996-03. Electrical apparatus for potentially explosive atmospheres, Increased safety "e"

DIN EN 50020: 1996-04. Electrical apparatus for potentially explosive atmospheres, Intrinsic safety "i"

DIN EN 50284: 2000-02. Special requirements for construction, test and marking of electrical apparatus of equipment group II, category 1 G

DIN EN 50081-1 (VDE 0839 part 81-1): 1993-03. Electromagnetic compatibility (EMC), Generic emission standard, Part 1: Residential, commercial and light industry

EN 50082-2: 1995-03. Electromagnetic compatibility, Generic immunity standard, Part 2: Industrial environment

NE 21 NAMUR recommendation „Electromagnetic compatibility (EMC) of industrial process and laboratory control equipment“, 1998-08

DIN EN 61010-1 (VDE 0411 part 1):1993-04. Safety requirements for electrical equipment for measurement, control and laboratory use, general requirements

pr **EN 50178** / **DIN EN 50178:** 1994-08: Electronic equipment for use in power installations

Directive 89/336/EWG (**CE** marking)

DIN EN 60068-2 (IEC 68-2): 1995-03. Environmental tests

DIN IEC 68-2-6: 1990-06. Electrical engineering, Basic environmental test procedures

DIN EN 60654, part 1 (IEC 654-1): 1994-02: Industrial process measurement and control equipment; Operating conditions; Climatic Conditions

DIN EN 60529: 2000-09: Degrees of protection by enclosures (IP Code)

DIN 2501: 1972-02: Flanges - Fitting dimensions [in German]

DIN 2527: 1972-04: Blind flanges [in German]

ANSI B 16.5: 1988: Pipe Flanges and Flanged Fittings

DIN 11851: 1998-11: Fittings for food, chemical and pharmaceutical industry - Stainless steel screwed pipe connections - Design for rolling in and welding-on

DIN EN 10088, Teil 1: 1995-08: Stainless steels - Catalogue of the stainless steels

DIN 55990: 1979-12: Verification of paints and similar coating materials; Powder mould coatings [in German]

HUG-3: **HART** FSK Physical Layer Specification Rev. 7.2: 1993-05

13 Quality assurance

KROHNE Messtechnik GmbH & Co. KG is certified to:

- DIN ISO 9001 / EN 29001 and
- KTA 1401 QSP 4A (nuclear power engineering)

Annex A: Technical data

1	Range of application	Distance, level, volume and reflection measurement of liquids, pastes, slurries, solids and particulate material on storage and process tanks or containers made of metal or concrete, and also in stilling wells
2	Mode of operation / system structure	FMCW-Radar in the X-Band (8.5-9.9 GHz) with digital signal processing; compact device, modular design
3	Input	
	<u>Measured variable</u> <u>Measuring range</u>	Primary variables: distance, reflection; derived variables: level, volume Min. tank height: 0.5 m max. measuring range: 40 m (optionally upto 100m); Wave-Stick: 20 m, BM 70 P = 35m
	<u>Block distance</u> <u>Rate of change in level</u>	Min. 0.2 to 1.0 m; see Sect. 3.3 ≤ 10 m/min; BM 70 P ≤ 1m/min
4	Output	
	Variant 1 Ex-e current output HART®	Type active (current source); Ex-e Current range 4-20 mA (error: 2 mA or 22 mA) Accuracy/linearity 0.05 % (rel. 20 mA; 25°C) Temperature drift ≤ 100 ppm/K (typically 30 ppm/K) Load impedance ≤ 500 Ω
	with switching output: and digital input:	max. 100 mA / 30 V DC or 30 V AC; internal resistance ≤ 20 Ω; potential-free to "freeze" the measured value; voltage: 5 to 28 V DC; input resistance: ≥ 1 k Ω; potential-free
	Variant 2 Ex-i current output HART®	Type passive (current sink); Ex-i Current range 4-20 mA (error 3.6 or 22 mA); 4 mA constant for HART®-Multidrop Temperature drift ≤ 100 ppm/K (typically 30 ppm/K) Accuracy/linearity 0.05 % (rel. 20 mA; 25°C) Supply voltage 8-30 V (terminals 31 and 32) Load impedance ≤ (U _S - 8 V) / 22 mA, (U _S = external supply voltage)
	with optional switching output:	6 ... 30 V; I _{Low} ≤ 2 V; I _{High} ≤ 900 μA (U = 30 V), I _{High} = 200 μA (U = 8 V)
	Variant 3 RS 485 interface	Transmission rate 1200 to 38400 bauds Address: 0 to 255 Protocols: KROHNE Protocol, Modbus-RTU, HART®
	with additional current output	Type active (current source); not communicable; Ex-e Current range 4-20 mA (error 2 mA or 22 mA) Accuracy/linearity 0.3 % (rel. 20 mA; 25°C) Temperature drift ≤ 200 ppm/K (typically 70 ppm/K) Load impedance ≤ 250 Ω When operated as switching output: Low: I < 2 mA; High: I = 22 mA (R ≤ 250 Ω) and no-load voltage ≤ 18 V
	Variant 4: PROFIBUS-PA (Ex-i) Hardware	
	Physical	to IEC 61 158-2 and the FISCO model
	Bus characteristics	9 ... 30 V; 0.3 mA max.; 4.2 W max.
	Base current	10 mA
	Default current	6 mA
	Variant 5: Foundation Fieldbus (FF)	see Supplementary Instructions
	Breakdown signal	Current output: error signal 2/22 mA or 3.6 mA (Ex-i), plain text in local display Switching contact: opening or closing of the contact Digital interfaces: error flags
5	Measuring accuracy	
	<u>Error of measurement</u>	Reference conditions and error curves: see Sect. 5.1 and 5.2
	<u>Repeatability</u>	≤ 0.5 × error of measurement
	<u>Measured-value resolution</u>	BM 70 A: 1 mm; BM 70 P: 0.1 mm
	<u>Effect of ambient temperature</u>	No significant effect on measured value(- 1 ppm/°C); (see also signal outputs)
6	Operating conditions	
6.1	Installation conditions	Avoid interference reflections and multiple reflections
6.2	Ambient conditions	
	<u>Hazardous locations</u>	BM 70 A/P Ex: Zone 0,1,2; IIC/IIB, T6...T2
	<u>Ambient temperature at signal converter</u>	-20...+55°C (-24...+131°F)
	<u>Flange temperature</u>	Functional range: -40...+70°C (-40...+158°F) Horn antenna, Wave-Guide (T _{amb} ≤ 50°C/122°F): -30...+130°C (-22...+266°F)

Horn antenna, Wave-Guide (Tamb ≤ 55°C/131°F): -30...+120°C (-22...+248°F)
 High-temperature version with:
 - FFKM gasket (Kalrez 4079/Parofluor V8545-75): -30...+250°C (-22...+482°F)
 (safety limit 280°C/536°F)
 - Kalrez 2035 gasket: -30...+210°C (-22...+410°F)
 - Viton gasket: -30...+200°C (-22...+392°F)
 - FEP-sheathed gasket: -30...+200°C (-22...+392°F)
 -20...+100°C (-4...+212°F)

Wave-Stick:
Environment class

pressure-dependent up to +150°C/302°F
 Locations exposed direct to open-air climate, D1 Severity in conformity with EN 60654-1

Protection category
Shock resistance

(signal converter) IP 66 / IP 67
 Impact test to EN 61010, Sect. 8.2 with 0.5 J energy; drop test to prEN 50178

Vibration endurance limit
EMC

IEC 68-2-6 and prEN 50178 (10-57Hz:0.075 mm/57-150 Hz:1 g)
 EN 50081-1, EN 50082-2; NAMUR Recommendation

6.3 Product conditions

Physical properties

No effect on measurement results; to ensure reliable measurements, the relative permittivity should have the following minimum values:

Relative permittivity

$\epsilon_r \geq 1.5$; $\epsilon_r < 3$: stilling well recommended; Wave-Stick immersed: $\epsilon_r \geq 4$

Limitations

Liquid ammonia (NH₃); liquid hydrogen (H₂); liquid helium (He)

Temperature of product

unrestricted (but be aware of ambient and flange temperatures)

Operating pressure

dependent on flange size and pressure rating (see Table)

Horn antenna/Wave-Guide

Standard: max. 64 bar (higher on request)

Wave-Stick

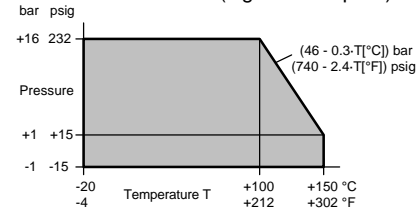

7 Component parts

Dimensions and weights

see Sect. 7.2

Materials

Housing: signal converter
 Flange system, antenna, extension

Aluminium with electrostatic powder coating; sight window: glass
 Stainless steel 1.4571 or 1.4435, Hastelloy C4 or B2, titanium, tantalum;
 (other materials on request)

Gaskets

FFKM (Kalrez 4079 or Parofluor V8545-75); Kalrez 2035; Viton (FPM); FEP-sheathed (basically, all versions include PTFE as the material in contact with the product)

Wave-Stick

only PTFE in contact with product; flange made of 1.4571 (316 Ti)

Process connection

Horn antenna/Wave-Guide

DIN 2501 / DIN 2526, Form C DN 50 ... DN 200 / PN 6 ... PN 64;
 ANSI B 16.5 2" ... 8", Class 150/300 lb/RF;

Wave-Stick

DIN 2501 / DIN 2526, Form C DN 50 ... 150;
 ANSI B 16.5 2" ... 6";

Dairy screw connection

DIN 11 851 DN 50, DN 65, DN 80
 SMS 1145 51 mm, 63 mm, 76 mm

Tri-Clamp connection

ISO 2852 2" ... 4"

Electrical connection

Cable entries: 3x M25x1,5
 Terminals: 0.5-2.5 mm² (solid conductor: max. 4 mm²)
 PE or FE and PA: U-clamp terminal (max. 4 mm²)
 Shielding for RS 485 cable and for current output cable > 100 m

8 User interface

Keypad

3 keys

Magnetic sensors

operation with magnetic pin without opening the housing

Local display

2-line illuminated LCD + 6 status markers

User language

German, English, French, Italian, Spanish, Portuguese, Swedish

Units of measurement

Length: m, cm, mm, inch, ft, %
 Volume: m³, Liter, US Gal, GB Gal, ft³, bbl, %
 Conversion unit: any text

9 Power supply

24 V DCAC

18-31.2 V DC or 18-26.4 V AC (45-66 Hz)

115/230 V AC

optionally: 100-120 V AC (tolerance: 85-127V),
 200-240 V AC (tolerance: 170-254V); 45-66 Hz

Power consumption

Typically 7.5 - 10 W / 12 VA

Annex B: Type code / nameplates

Type code

See nameplate on signal converter and flange system (places not needed in the type code may be omitted):

BM70 . . / . / . - E Ex
1 2 3 4 5 6

- 1: Tank level gauge
- 2: Signal converter series
 - 70A : Advanced
 - 70P : Precision
 - 700 : Low Cost
 - 702 : 2-wire
- 3: Symbol for type of protection for the signal outputs
 - i : intrinsically safe I/O function
 - unassigned : non intrinsically safe I/O function
- 4: Symbol for type of protection for the terminal compartment
 - E : terminal compartment in Increased Safety "e" (standard)
 - D : terminal compartment as Flameproof Enclosure "d" (option)
 - unassigned : intrinsically "ia" (BM 702)
- 5: Ambient temperature range
 - S : Extended range -40°C ... +55°C
 - unassigned : Standard range -20°C ... +55°C
- 6: Territory of application for explosion protection certification
 - E : Europe (EG, CENELEC)
- 7: Safety function
 - Ex : explosion-protected electrical equipment

Kennzeichnung des Flanschsystems (siehe Flansch-Datenschild):

..(1).. ..(2)..(3)..... nicht-explosionsgeschützte Ausführung
..(1).. ..(2)..(3)..... - E Ex ..(4).. explosionsgeschützte Ausführung

- (1) Flange system series
 - V96 : Flange system V96
 - WS : Flange system Wav-Stick
 - EA : Enamel antenna system
 - LP : LP flange system
- (2) Material of waveguide window
 - unassigned : standard (stainless steel)
 - H : Hastelloy window (T min = -60°C)
- (3) Materials of wetted parts
 - Flange system V96:
 - » Antennas and flanges, including coating:
 - SS : stainless steel
 - HB : Hastelly B
 - HC : Hastelloy C
 - Ti : Titanium
 - Ta : Tantalum
 - Mo : Monel
 - » Gasket materials:
 - FFKM : Kalrez™ 4079 or Parofluor™ V8545-75
 - K2035 : Kalrez™ 2035
 - K1091 : Kalrez™ 1091
 - FPM : Viton™
 - FEP : FEP-sheathed gasket

- Flange system WS
- LPTFE : PTFE conductive
- PTFE : PTFE non-conductive
- SS PTFE : stainless steel / PTFE non-conductive
- SS PP : stainless steel / PP non-conductive

- Flange system EA
- EM PTFE: Enamel + PTFE

- (4) Field of application, Device Group II
- 1G : Category 1G (application in Zone 0)
 - 2G : Category 1G (application in Zone 0)

Informationen on nameplates (example)

Signal converter:

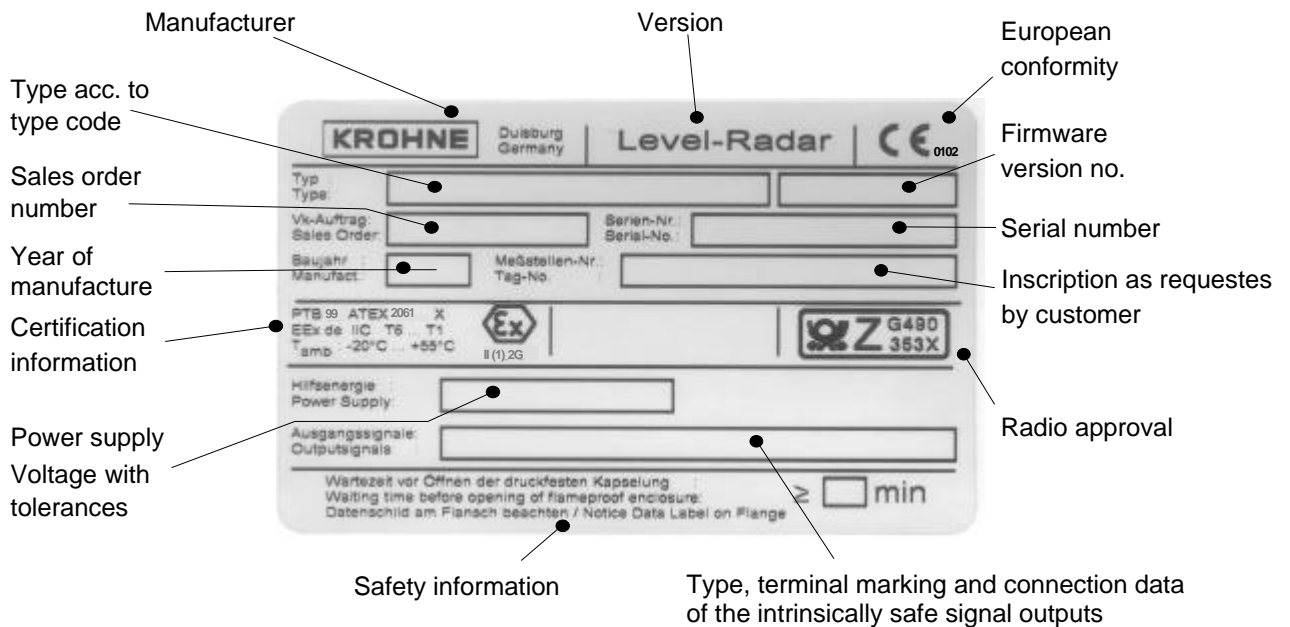

Flange system:

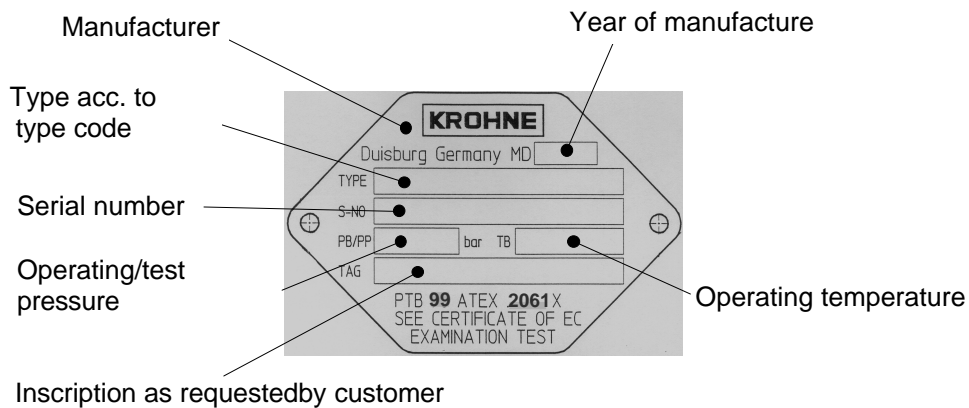

Sanitary connection / G 1 1/2" thread:

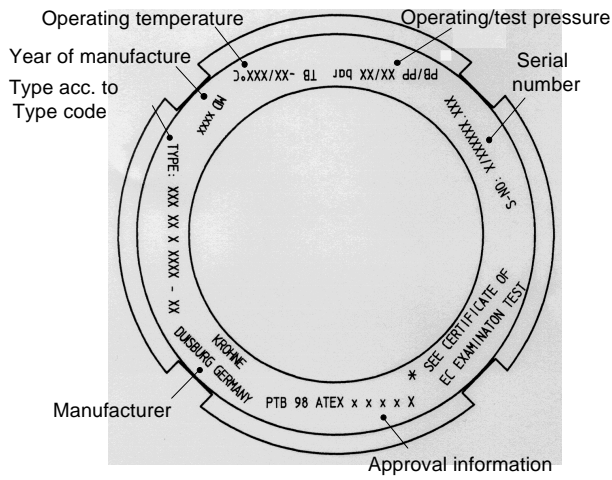

Attention!
 When mounting the G 1 1/2" screw connection you have to take care that the marking on the wrench faces will not be damaged (do not use pipe wrench!)

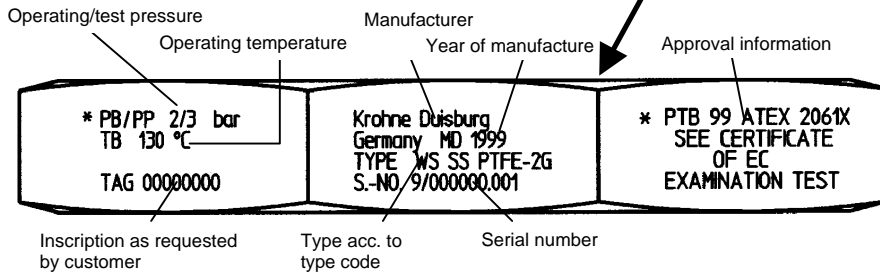

Annex C: Spare parts

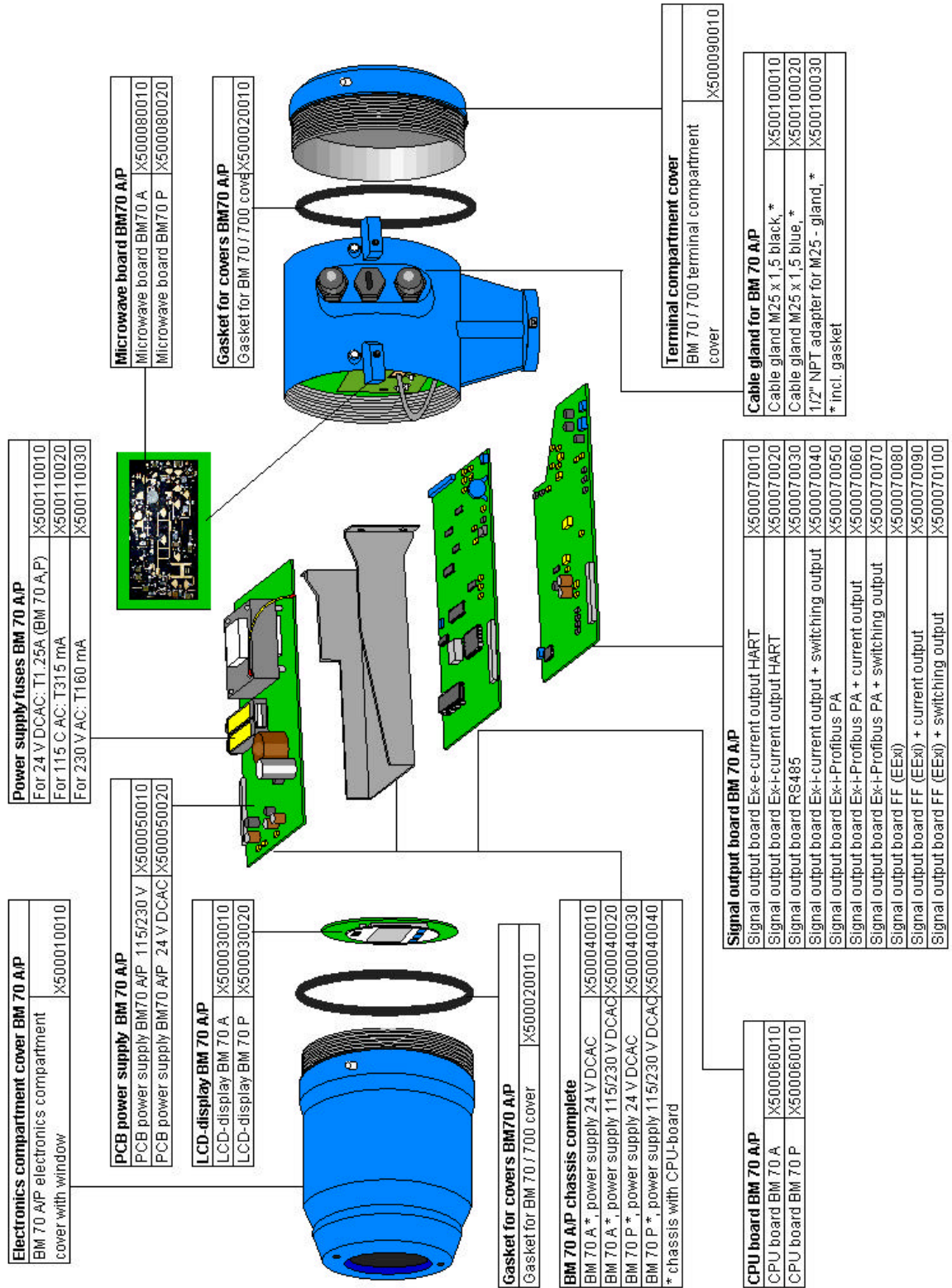

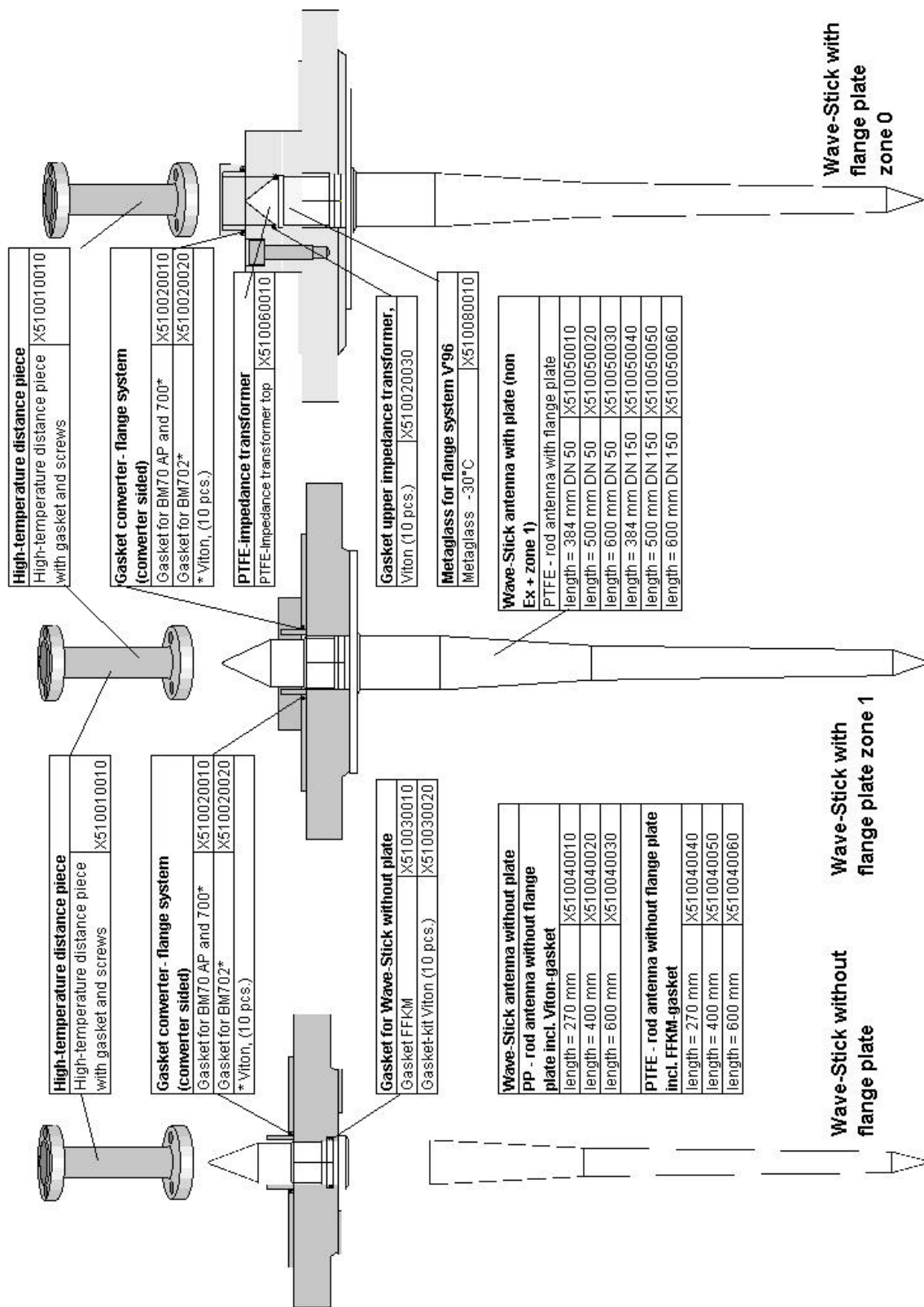

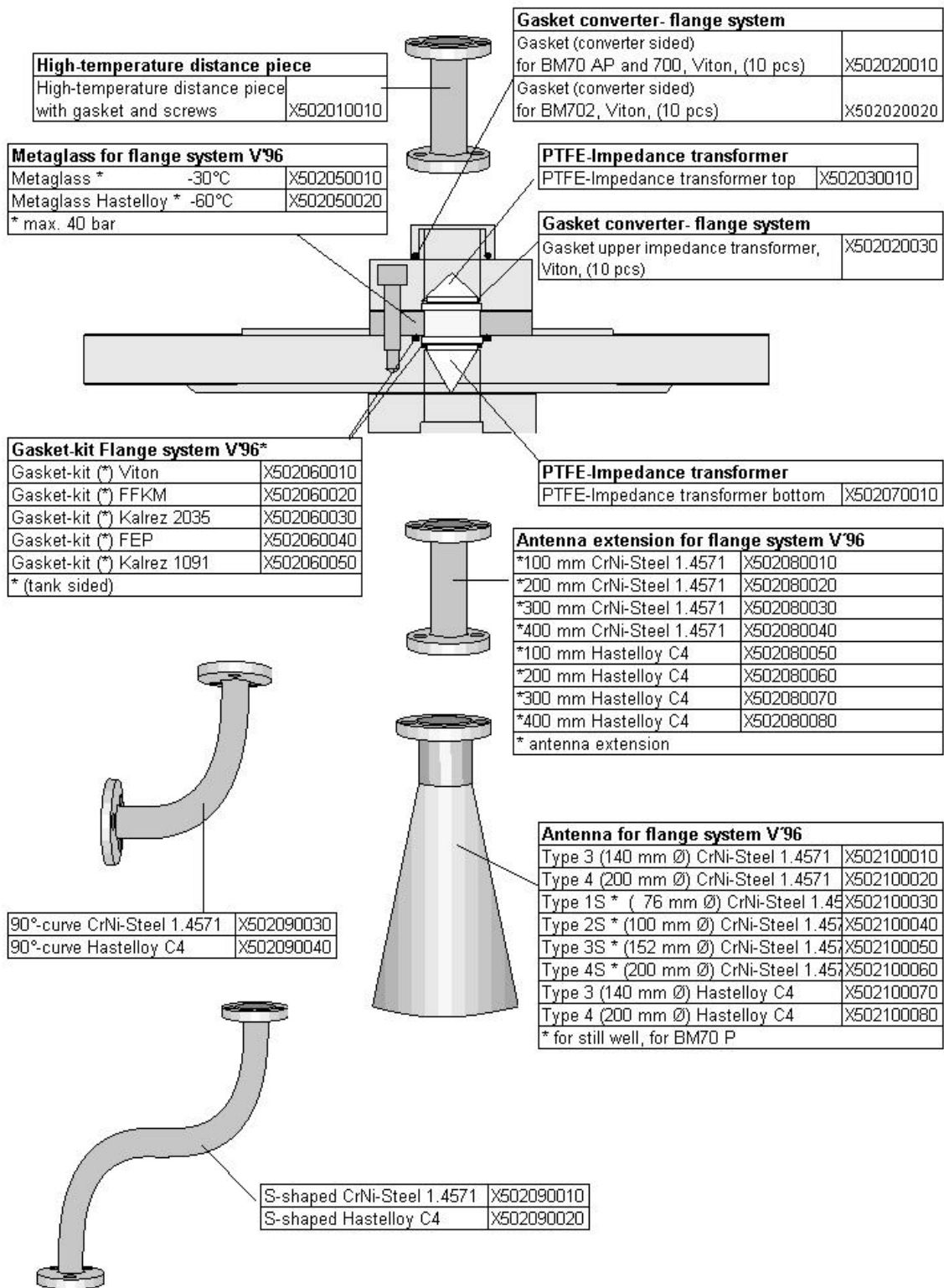

Annex D: Signed declaration to accompany a device returned to KROHNE

If you need to return level gauges for testing or repair to KROHNE

If installed and operated in accordance with these operating instructions, your level gauge will rarely present any problems.

Should you nevertheless need to return a device for checkout or repair, please pay strict attention to the following points.

Due to statutory regulations concerning protection of the environment and the health and safety of our personnel, KROHNE may only handle, test and repair returned level gauges that have been in contact with liquids if it is possible to do so without risk to personnel and environment. This means that KROHNE can only service your unit if it is accompanied by a certificate in line with the following model confirming that the device is safe to handle. If the unit has been operated with toxic, caustic, flammable or water-endangering liquids, you are kindly requested

- to check and ensure, if necessary by rinsing or neutralizing, that all cavities are free from such dangerous substances,
- to enclose a certificate with the level gauge confirming that it is safe to handle and stating the liquid used.

KROHNE regret that they cannot service your level gauge unless it is accompanied by such a certificate.

SPECIMEN certificate

Company: Address:

Department: Name:

Tel. No.:

The enclosed level gauge

BM70A/P: KROHNE Order No. or Series No.:

has been operated with the following liquid
.....

Because this liquid is

water-endangering * / toxic * / caustic * / flammable *

we have

- checked that all cavities in the unit are free from such substances *
- flushed out and neutralized all cavities in the unit *

(* delete where not applicable)

We confirm that there is no risk to man or environment through any residual liquid contained in this level gauge.

Date: Signature:

Company stamp:

Annex E: Table on documentation of device configuration

CHECK LIST PARAMETERS BM 70 A/P .Vers.:..... Date:			
Device No. : Comm. No.			
Location..... :			
Contact person..... : Telephone..... :			
Remarks :			
.....			
Menu item..... Changed on :			
.....			
Fct.	<u>Configuration parameters (excerpt)</u>		
3.1.1	Tank height	:	:
3.1.2	Block distance	:	:
3.1.3	Antenna	:	:
3.1.4	Antenna extension.....	:	:
3.1.5	Distance piece	:	:
3.1.6	Still well / diameter	:	:
3.1.7	Offset, reference	:	:
3.1.8	Offset, tank bottom.....	:	:
3.3.1	Current output, function	:	:
3.3.2	Current output, range/error.....	:	:
3.3.3	Min. scale for current	:	:
3.3.4	max. scale for current.....	:	:
3.3.5	Baud rate.....	:	:
3.3.6	Address	:	:
3.3.7	Protocol.....	:	:
3.5.2	Empty-tank spectrum	:	:
3.5.3	Time constant	:	:
3.5.4	Tracking speed	:	:
3.5.5	Multiple reflections (Yes/No)	:	:
3.5.6	Block distance detect.(Yes/No)	:	:
3.5.7	Function FTB	:	:
3.5.8	Epsilon-R	:	:
3.5.9	Tank type	:	:
3.6.1	Switching output, function	:	:
3.6.2	Switching output, limit type.....	:	:
3.6.3	Switching output, threshold	:	:
3.6.4	Switching output, hysteresis	:	:

Annex F: Index

Address	4.6, 8.6.9	Heating device	6.1.7
Agitator	7.5, 8.6.16	High-temperature version	6.2.3, 7.2, 7.4, 7.8, 10.3
Ambient temperature	5.8, 6.2.2	Horn antenna	3.3, 6.1.2, 6.1.3, 6.3.5, 7.2
Antenna extension	6.1.3, 7.4, 8.6.3	Hot start	4.2, 4.8
Antenna size	5.2, 6.1.4, 7.2, 7.5	Hysteresis	5.4, 8.6.17
Antenna type	8.6.3	Impact resistance	6.2.8
Application range	1	Installation	6.1
Approvals	6, 10	Insulation	9.4
Assembly	7.4	Interference	4.8, 8.10
Baud rate	4.6, 8.6.9	Internals	6.1.2, 6.1.6, 8.6.12
Block distance	3.3, 8.6.3	Intrinsic safety	4.3, 7, 7.8
Block distance detection	3.4, 8.6.14	IT system	9.2, 9.3
BM 70 A Precision	5.2	Keys	8.1, 8.2
Breakdown information	4.7	KROHNE Protocol	4.6, 8.6.9
Cable entries	7.8	Language of display texts	8.6.10
Configuration	8.4, 8.5, 8.6, Annex E	Load impedance	4.2, 4.3, 4.5
Configuration menu	8.3, 8.4	Local display	8.1
Connecting cable	7.8	Long-term drift	5.7
Connection diagrams	7.8	magnetic sensors	8.1
Conversion table	8.5.2, 8.6	maintenance	6.4
Cooling device	6.1.7	manhole cover	6.1.2
Current output	4.2, 4.3, 4.5, 7.8, 8.6.8, 8.7.8	markers	4.8, 8.1, 8.8.2
Curved extension	6.1.6, 8.6.3, 8.6.4	materials of construction	7.6
Cylindrical tank	6.1.2	Measured value, calculation of	8.11
Device configuration	8.4, 8.6, Annex E	Measured value, resolution of	5.4
Digital Communication	4.1, 4.6, 8.6.9	Measured variables	3.1
Digital input	4.2, 4.8	Measurement principle	2.1
Dimensions	7.2	Measuring accuracy	5
Display	8.1, 8.6.7	Measuring range	3.2
Distance piece	6.2.3, 7.4, 8.6.2	ModBus	4.1, 8.6.9
Documentation	Page 3	Modularity	2.3, 4.1
Electrical connection	7.8	Multidrop	4.1, 4.4
EMC	6.2.10, 10.5	Multiple reflections	8.6.14
Empty (-tank) spectrum	8.6.12	Nameplate	Annex B
Environment class	6.2.6	Operating pressure	6.3.5
Error	8.6.7, 8.6.8, 8.6.17, 8.8	Operating voltage	9.1, 9.3
Error message	4.7, 8.6.17, 8.8.3	Operating voltage, changeover of	9.3
Error of measurement	5.2	Operator control concept	8.3
Firmware version	page 4, 8.7.5	Order information	11
Flameproof enclosure	7, 9.3	Order numbers	Annex C
Flanges	7.2; 7.4	Out-of-range performance	3.4
Flange system	2.3, 7.4	Output	4
Flange temperature	6.2.3	Parameter setting, see Configuration	
FMCW-Radar	2.1	PC-CAT	8.12
Foundation Fieldbus (FF)	4.1, 8.6.9	Point-to-point	4.1, 4.4
Freeze	4.8	Positioning	6.1.2
Frequency sweep	2.1	Post Office /Radio approvals	10
FTB	8.6.15	Power supply	9
Functional checks	8.7	Pressure separation	2.3
Functional ground	7.8	Product conditions	6.3
Fuses	9.2, 9.3	Product temperature	6.3.4, 10.3
Gaskets	6.2.3, 7.6.3	Profibus	8.6.9
HART®	4.1, 4.4	Protection category	6.2.1, 6.2.7, 7
Hazardous-duty "Ex"	6, 6.2.1, 7, 9.3, 10		

Protocol	8.6.9	Volume measurement	3.1, 8.5.2
Purging device	6.1.7	Warranty	Page 3
Quality assurance	13	Wave-Guide	6.1.2, 6.1.5, 7.1
Reference conditions	5.1	Wave-Stick	3.3, 6.1.3, 7.1, 7.2, 7.5
Reference offset	8.6.6	Weight	7.2
Reflection	3.1, 8.6.1		
Rel. Permittivity	6.3.2		
Repeatability	5.3		
Replacement of signal converter	2.3, 7.3		
Returning the device	Annex D		
RS 485	4.1, 4.6, 8.6.9		
Safety conductor	9.4		
Safety lock	9.3		
Safety, advice on	Page 3, 6, 9.4		
Setting, see Configuration			
Shielding strip	6.1.8		
Side vessels	6.1.2		
Signal converter	7.6.1, 2.3, 7.4		
Signal output	4, 5.8		
Signal processing	2.2		
Software history	page 4		
Spare parts	Annex C		
Spectrum	2.2, 8.6.12		
Standards	12		
Stilling well	3.3, 6.1.4, 6.1.2,		
8.6.5			
Storage temperature	6.2.5		
Sunshade	6.1.9, 6.2.2		
Supply scope	Page 3		
Supply voltage	4.3		
Switching output	4.2, 7.8, 8.6.17		
Tag name	8.6.10		
Tank bottom offset	8.6.6		
Tank bottom tracking	8.6.15		
Tank fitting	6.1.3, 6.1.8		
Tank height	3.2, 8.5, 8.6.2, 8.6.11		
Tank type	8.6.16		
Tank wall	6.1.2		
Technical data	9.1, Annex A		
Temperature	5.8, 6.2.2, 6.2.3, 6.2.4, 6.2.5, 6.3.4, 10.3		
Temperature drift	5.8		
Terminals	7.8		
Terminating resistor	7.9		
Test functions	8.7.1		
Threshold	8.6.17		
Time constant	5.5, 8.6.13		
TN system	9.2		
Tracking speed	8.6.13		
Transient recovery time	5.5		
Transmission angle	6.1.1		
Transport	Page 3		
Turn-on characteristics	5.6		
Type code	Annex B		
Units	8.6.1		
Vessel, see Tank			
Vibration endurance limit	6.2.9		