

## Installation and operating instructions

# IFC 110 F V2.0 IFC 110 F-EE<sub>x</sub> V2.0

## Signal converters for electromagnetic flowmeters

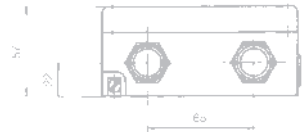
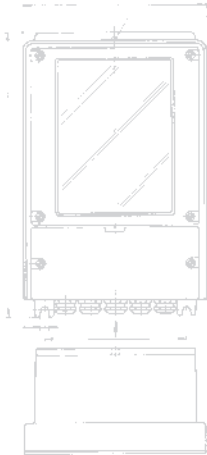

### Applicable to Software Versions

- Display & control unit  
No. **3.19937.02.00**
- A/D converter  
No. **8.13393.02.00**
- Outputs/inputs (I/O)  
No. **3.16230.01.00**

### How to use these Instructions

Flowmeters are delivered ready for operation.

The flow sensor must be installed in the pipeline as described in the instructions for installation inside the packing of the flow sensor.

- Connection of power supply (Sect. 1.1-1.2)
- Electrical connection between IFC 110 F and primary head (Sect. 1.3)
- Electrical connection of outputs and inputs (Sect. 2)
- Start-up (Sect. 3)

Pages 4- 5  
Pages 6-13  
Pages 14-22  
Page 23

**Power the flowmeter. THAT'S ALL. The system is operative.**

**Operator control of the IFC 110 F signal converter** is described in Sect. 4.

Variable area flowmeters

Vortex flowmeters

Flow controllers

**Electromagnetic flowmeters**

Ultrasonic flowmeters

Mass flowmeters

Level measuring instruments

Communications technology

Engineering systems & solutions

Switches, counters, displays and recorders

Heat metering

Pressure and temperature

## Signal converter versions

The operating data are factory-set to your ordered specifications.

- |   |   |
|---|---|
| <b>IFC 110 F / D</b><br>(Standard)          | <b>Standard version</b> , with local display and control elements   |
| <b>IFC 110 F / D / MP</b><br>(Option)       | <b>Same as display version</b> , additional with magnetic sensors (MP)                                    |
| <b>IFC 110 F / D / MP / EEx</b><br>(Option) | <b>Same as display version (D + MP)</b> ,<br>for operation with flow sensors installed in hazardous areas |
| <b>IFC 110 F / RS 485</b>                   | <b>Same as standard version</b> ,<br>but additionally with different interfaces                           |

## Items included with supply

- **Signal converter** in the version as ordered, see above.
- **Signal cable** in the version and length as ordered (standard: signal cable A, length 10 m / 30 ft)
- **Condensed installation and operating manual** in the ordered language for installation, electrical connection, start-up and operator control of the signal converter.
- **Service Manual** in english language.

### Please note!

In the **Installation and Operating Manual** there are hints with Sect. Numbers which you can find in the **Handbook / Service Manual** only!

## Instrument nameplates

### Signal converter (example)

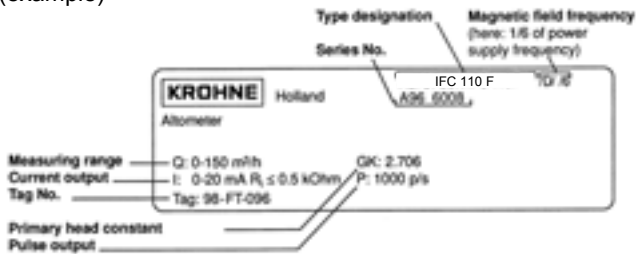

### Signal converter IFC 110F-EEx (example)

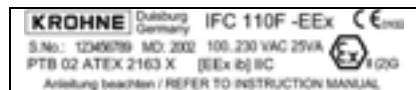

### Flow sensor (example)

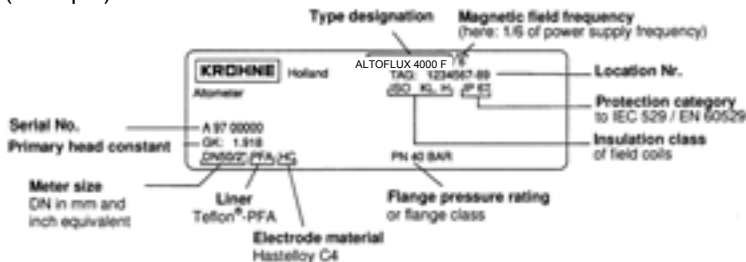

---

## System description

---

Electromagnetic flowmeters are precision instruments designed for linear flow measurement of liquid products

The process liquids must be electrically conductive:  $\geq 5 \mu\text{S/cm}$   
(for cold demineralized water  $\geq 20 \mu\text{S/cm}$ ).

The full-scale range  $Q_{100\%}$  can be set as a function of the meter size: flow velocity of 0.3 - 12 m/s or 1 - 40 ft/s (s. Section 10.4.).

---

## Product liability and warranty

---

The electromagnetic flowmeters are designed solely for measuring the volumetric flowrate of electrically conductive, liquid process products.

These flowmeters are available for use in hazardous areas.  
Special regulations apply in this case, which are given in the special EEx directions.

Responsibility as to suitability and intended use of these electromagnetic flowmeters rests solely with the operator.

Improper installation and operation of the flowmeters (systems) may lead to loss of warranty.

In addition, the "General conditions of sale" forming the basis of the purchase contract are applicable.

If flowmeters need to be returned to KROHNE, please note the information given on the last-but-one page of these Instructions. KROHNE regrets that it cannot repair or check your flowmeter(s) unless accompanied by the completed form sheet.

---

## CE / EMC / Standards / Approvals

---

The here described Electromagnetic flowmeters meet the NAMUR Directive NE21, the protection requirements of **Directive 89/336/EEC** in conjunction with **EN 61326-1** (1997) and **A1** (1998), as well as **Directives 73/23/EEC** and **93/68/EEC** in conjunction with **EN 61010-1**, and bear the **CE marking**.



---

## Software history

---

Display & control unit		Amplifier (ADC)		Inputs and outputs (I/O)	
Software	Status	Software	Status	Software	Status
<b>3.19937.02.00</b>	current	<b>8.13393.02.00</b>	current	<b>3.16230.01.00</b>	current



### IMPORTANT!

In respect of EEx versions, pay regard to all directions marked with the  symbol, and also the information given in Sect. 6.1 and 13.

**Only the EEx flow sensor may be installed in the hazardous area. The EEx certified signal converter must be installed outside the hazardous area!**

---

# 1 Electrical connection: power supply

---

## 1.1 Location and important installation notes ..... PLEASE NOTE !

- **Electrical connection in accordance with VDE 0100** "Regulations for the erection of power installations with nominal voltages up to 1000 V" or **equivalent national regulations**.
- Do not cross or loop **cables inside the terminal compartment**.
- Use **separate wiring** (PG screwed cable entries) for power supply, field current lines, signal lines, outputs and inputs.
- **Hazardous areas** are subject to special regulations, see Section 6.1 and special installation instructions for hazardous-duty versions.
- Do not expose signal converter and switchgear cabinets with built-in converters to direct **sunlight**. Install a sunshade if necessary.
- **Signal converters installed in switchgear cabinets** require adequate cooling (e.g. by fans or heat exchangers).
- Do not expose signal converters to intense **vibration**.
- Keep the **distance between the flow sensor and signal converter** as small as possible, for empty pipe detection (EPD)  $\leq 20$  m /  $\leq 66$  ft. Observe maximum lengths of signal and field current lines (see Section 1.3.4).
- Use **KROHNE signal line A** (type DS, standard) or **signal line B** (type BTS, bootstrap, optional), standard length 10 m (33 ft).
- Generally use bootstrap signal lines B (type BTS) for **PROFIFLUX 5000 F and VARIFLUX 6000 F flow sensors** sized at DN 2.5-15 and 1/10"-1/2" and for contaminated liquids which tend to form electrically insulating deposits.
- Always **calibrate** flow sensor and signal converter **together**. During installation particular care should therefore be given to **identical settings of flow sensor constant GK** (see instrument nameplate of flow sensor). In case GK constants are not identical, the signal converter must be adjusted to the flow sensor GK (see Sections 4 and 8.5).
- **Dimensions of signal converter** see Section 10.3.



### IMPORTANT!

For EEx versions, also pay regard to all directions included in Sect. 6.1 and 13. **Only the EEx flow sensor may be installed in the hazardous area. The EEx certified signal converter must be installed outside the hazardous area!**

## 1.2 Power supply - connection

### PLEASE NOTE !

- Type of enclosure IP 65 to IEC 529 / EN 60529 equivalent to NEMA 4/4X.
- Dimensioning: the flowmeter housing protecting the electronic equipment against dust and moisture must always be kept closed. The selected clearances and creeping distances comply with VDE 0110 and/or IEC 664 regulations for contamination grade 2. Supply circuits and output circuits are designed to meet standards of overvoltage classes III and II, respectively.
- Fuse protection, disconnecting device: fuse protection for the feeding power circuit, and also a disconnecting device (switch, circuit breaker) for isolating the signal converters must be provided (see also Sect. 1.3.5 and 1.3.6).

### 100-230 V AC (tolerance range 85-255 V AC)

- **Observe information on the instrument nameplate**, power supply voltage and frequency.
- The **protective conductor PE** of the power supply **must be connected** to the separate U-clamp terminal inside the terminal compartment of the signal converter.
- **CAUTION**: do not remove the internal connection (line) inside the terminal compartment of the signal converter (**yellow/green wire**) between the U-clamp terminal and terminal 10 - **protective conductor (protection class I instrument)**.
- **Connection diagrams I - IV** for the power supply and for the electrical connection between flow sensor and signal converter, see Sections 1.3.5 (Standard) and 1.3.6 (EEx).

### 24 V AC / DC (tolerance ranges: AC 20.4 - 26.4 V / DC 18 - 31.2 V)

- **Observe information on the instrument nameplate**, power supply voltage and frequency.
- For technical reasons concerning the measuring process, a **functional grounding conductor FE** has to be connected to the separate U-clamp terminal inside the terminal compartment of the signal converter.
- A facility providing a **reliable electrical separation (PELV)** has to be provided for connections to functional extra-low voltages (24 V AC / DC) - (VDE 0100 / VDE 0106 and/or IEC 364 / IEC 536 or equivalent national regulations).
- **Connection diagrams I - IV** for the power supply and for the electrical connection between flow sensor and signal converter, see Sections 1.3.5 (Standard) and 1.3.6 (EEx).



#### IMPORTANT!

For EEx versions, also pay regard to all directions included in Sect. 6.1 and 13. **Only the EEx flow sensor may be installed in the hazardous area. The EEx certified signal converter must be installed outside the hazardous area!**

**Warning:** Instrument must be properly grounded to avoid personnel shock hazard.

### 1.3 Electrical connection of flow sensors

#### 1.3.1 General remarks on signal lines A and B and field current line C

Proper operation of the equipment is ensured when KROHNE signal lines A and B are used with foil screen and magnetic shield.

- Signal lines must be firmly installed.
- Shields are connected via stranded drain wires.
- Underwater or underground routing is possible.
- Insulating material flame-retardant to IEC 332.1 / VDE 0742.
- Low-halogen, unplasticized signal lines which remain flexible at low temperatures.

#### Signal line A (type DS) with double shielding

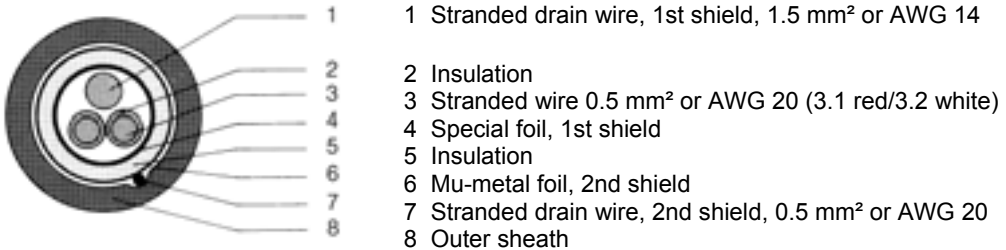

#### Signal line B (type BTS) with triple shielding (bootstrap line)

The bootstrap technology always controls the individual shields (3) of the signal converter exactly to the voltage which is supplied to the signal conductors (5). As this prevents voltage differences between the individual shields (3) and signal conductors (5), no current flows via the line capacitances between 3 and 5. The line capacitance seems to become "zero".

This allows greater cable lengths in case the electric conductivity of the liquid to be measured is low.

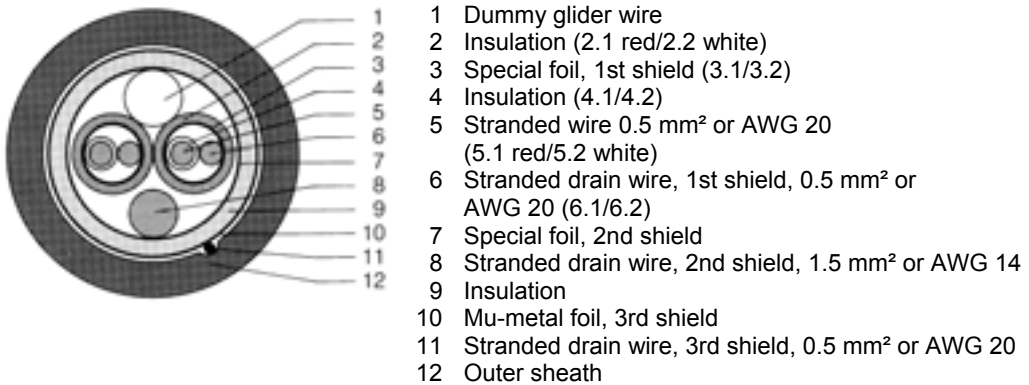

#### Field current line C1

Line 2 x 0.75 mm<sup>2</sup> (18 AWG) Cu or 2 x (4 x) 1.5 mm<sup>2</sup> (14 AWG) Cu (Cu = copper cross section)

The cross section depends on the required cable length.

For max. permissible cable lengths please refer to Section 1.3.4



#### **IMPORTANT!**

For EEx versions, also pay regard to all directions included in Sect. 6.1 and 13.  
**Only the EEx flow sensor may be installed in the hazardous area. The EEx certified signal converter must be installed outside the hazardous area!**

### 1.3.2 Stripping (preparation) of signal cables

**Please note:** The numbers in the drawings designate the stranded drain wires of signalling cables A and B, see sectional drawings in Sect. 1.3.1.

#### Flow sensor

Length	flow sensor	
	mm	inch
a	90	3.60
b	8	0.30
c	25	1.00
d	8	0.30
e	70	2.80

#### Converter

Length	Converter	
	mm	inch
a	50	2.00
b	8	0.40
d	8	0.40
e	20	0.80

**Signal cable A (type DS),  
double shielding  
for flow sensor**

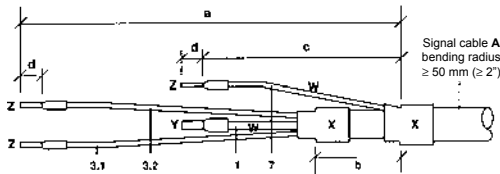

**Signal cable A (type DS),  
double shielding  
for IFC 110 F Converter**

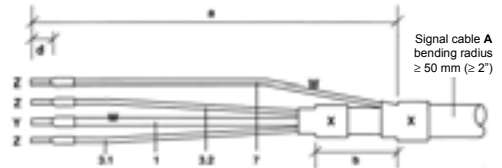

**Signal cable B (type BTS),  
with triple shielding (bootstrap)  
for flow sensor**

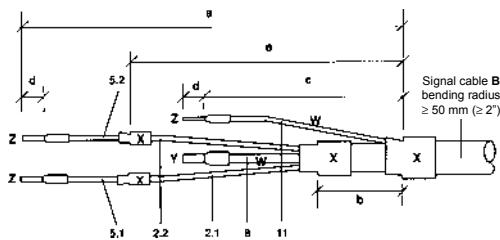

**Signal cable B (type BTS),  
with triple shielding (bootstrap)  
for IFC 110 F Converter**

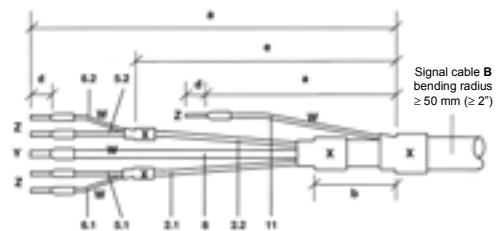

#### Customer-supplied materials

<b>W</b>	Insulation tubing (PVC), Ø 2.0-2.5 mm (Ø 1")
<b>X</b>	Heat-shrinkable tubing or cable sleeve
<b>Y</b>	Wire end sleeve to DIN 41 228: E 1.5-8
<b>Z</b>	Wire end sleeve to DIN 41 228: E 0.5-8

### 1.3.3 Grounding of flow sensor

- The flow sensor must be correctly connected to ground.
- The grounding cable may not transfer interference voltages.
- Do not use the grounding cable to connect more than one device to ground.
- In hazardous areas the grounding line is also used for potential equalizing purposes. Special grounding instructions are contained in the installation instructions for hazardous-duty instruments (only supplied together with such instruments).
- The flow sensor is connected to ground by means of a **functional grounding conductor FE**.
- Special grounding instructions for the connection of several flow sensors are contained in the separate **installation instructions of the flow sensors**.
- These instructions also contain detailed descriptions on how to use grounding rings and how to install flow sensors in metal or plastic pipes or in pipes which are coated on the inside.

**Warning:** Instrument must be properly grounded to avoid personnel shock hazard.



#### **IMPORTANT!**

For EEx versions, also pay regard to all directions included in Sect. 6.1 and 13.  
**Only the EEx flow sensor may be installed in the hazardous area. The EEx certified signal converter must be installed outside the hazardous area!**



### 1.3.4 Cable lengths (max. distance between signal converter and flow sensor)

#### Abbreviations and explanations

The abbreviations used in the following tables, diagrams and connection diagrams stand for:

- A** Signal line A (type DS) with double shielding, max. length see diagram
- B** Signal line B (type BTS) with triple shielding, max. length see diagram
- C** Field current line, minimum cross section ( $A_F$ ) and max. length see table
- D** High-temperature silicone line,  $3 \times 1.5 \text{ mm}^2$  (14 AWG) Cu, with single shield, max. length 5 m (16 ft)
- E** High-temperature silicone line,  $2 \times 1.5 \text{ mm}^2$  (14 AWG) Cu, max. length 5 m (16 ft)
- A<sub>F</sub>** Cross section of field current line C in Cu, see table
- L** Cable length in m or ft
- K** Electrical conductivity of the process liquid
- ZD** Intermediate connection box required in connection with lines D and E for flow sensors  
ALTOFLUX 4000 F, PROFIFLUX 5000 F and VARIFLUX 6000 F for process temperatures exceeding 150°C (302°F).

#### Recommended length of signal line

for magnetic field frequencies  $\leq 1/6 \times$  power frequency

Flow sensor	Meter size		Signal line
	DN mm	Inch	
VARIFLUX 6000 F	2.5 - 15	$1/10$ - $1/2$	B1
	25 - 80	1 - 3	A1 / B3
PROFIFLUX 5000 F	2.5 -	$1/10$ -	B1
	4 - 15	$1/6$ - $1/2$	B2
	25 - 100	1 - 4	A1 / B3
ALTOFLUX 4000 F	10 - 150	$3/8$ - 6	A1 / B3
	200 - 1200	8 - 48	A2 / B4
ALTOFLUX 2000 F	150 - 250	6 - 10	A2 / B4
ECOFLUX 1000 F	10 - 150	$3/8$ - 6	A1 / B3
M900	10 - 300	$3/8$ - 12	A2 / B4

#### Please note!

For application with empty pipe detection (EPD) max. length < 20 m / 66 ft.

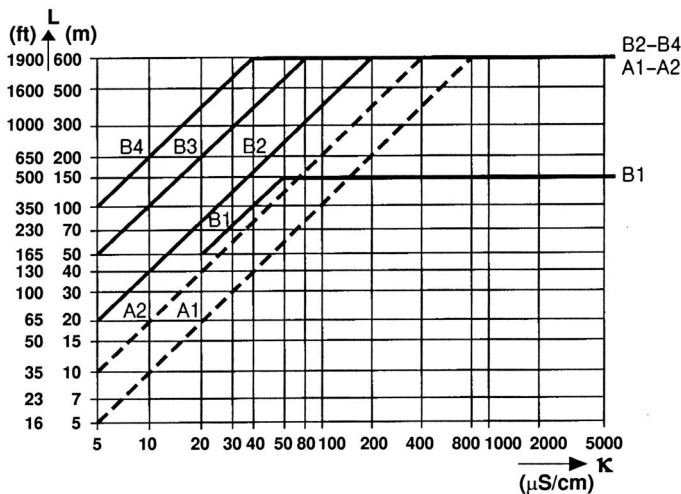

#### Max. length and minimum cross section of field current line

Length L		Cross section A <sub>F</sub> (Cu), minimum	
0 to 150 m	5 to 500 ft	2 x 0.75 mm <sup>2</sup> Cu	2 x 18 AWG
150 to 300 m	500 to 1000 ft	2 x 1.50 mm <sup>2</sup> Cu	2 x 14 AWG
300 to 600 m	1000 to 1900 ft	4 x 1.50 mm <sup>2</sup> Cu	4 x 14 AWG

### 1.3.5 Connection diagrams for power supply and flow sensors

#### Important remarks for circuit diagrams PLEASE NOTE !

- The figures in brackets indicate the stranded drain wires of the shields (see cross-sectional drawings of signal lines in Section 1.3.1).
- **Electrical connection to VDE 0100** "Regulations for the erection of power installations with nominal voltages up to 1000 V"
- **Power supply 24 V AC / DC:** protective extra-low voltages (PELV) acc. to VDE 0100/ VDE 0106 and/or IEC 364/IEC 365, or corresponding national regulations.
- **Systems to be used in hazardous areas** are subject to special regulations applying to electrical connections (see Section 1.3.6) for hazardous-duty instruments.
- **PE** = protective conductor      **FE** = functional ground conductor

	<p><b>IMPORTANT!</b></p> <p>Electrical connection of EEx flow sensors and EEx signal converters to be carried out as described in Sect. 1.3.6.</p>
--	--

<b>*</b>	Do not remove the internal connection (cable) inside the terminal compartment of the signal converter ( <b>yellow/green wire</b> ) between the U-clamp terminal and terminal 10 ( <b>protective conductor for protection class I instruments</b> ).
----------	---

**Process temperature below 150°C (302°F)**

**I Signal cable A (type DS)**

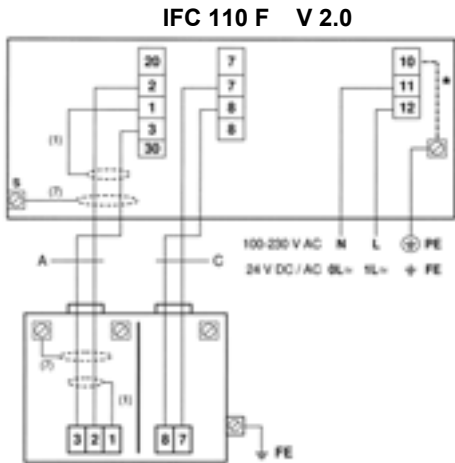

**Flow sensor**

**II Signal cable B (type BTS)**

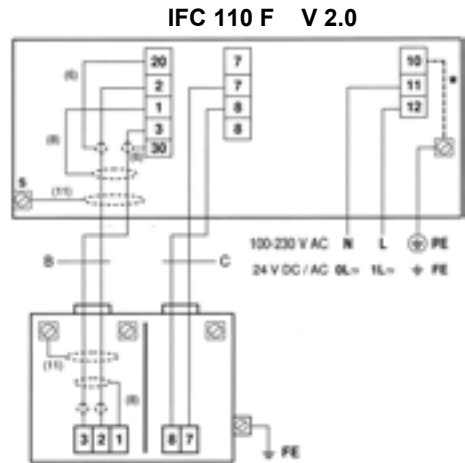

**Flow sensor**

**Process temperature above 150°C (302°F)**

**III Signal cable A (type DS)**

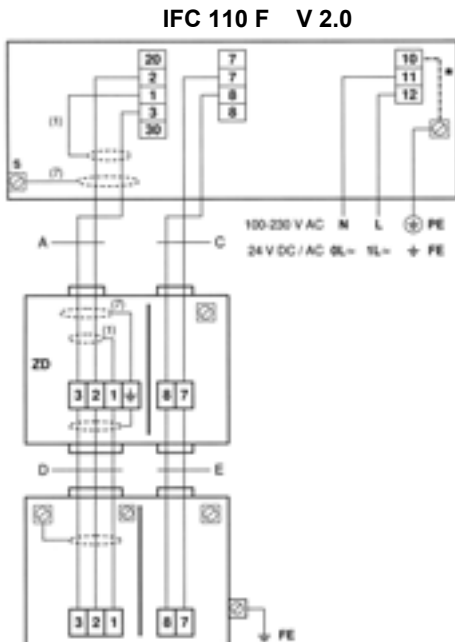

**Flow sensor**

**IV Signal cable B (type BTS)**

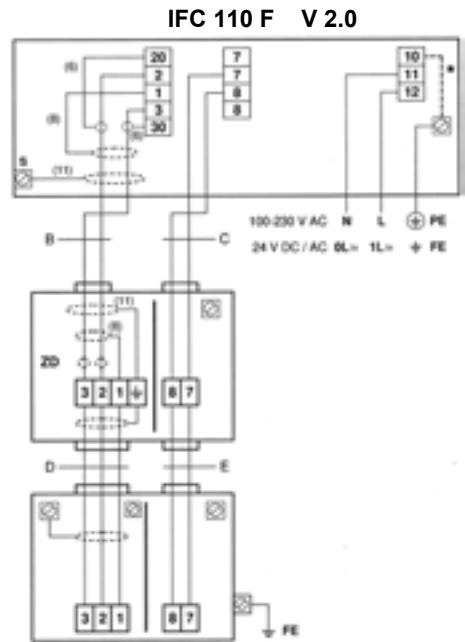

**Flow sensor**

### 1.3.6 EEx-Connection diagrams for power supply and flow sensors

#### PLEASE NOTE!

- The figures in brackets indicate the stranded drain wires for the shields (see cross-sectional drawing of signal cable in Section 1.3.1).
- The connections for the **intrinsically safe electrode circuit including the shield terminals** are safety-separated up to a peak value of 375 V from the terminals for the power supply, for the inputs/outputs and for the field circuit. They are galvanically isolated from the housing (PE/PA).
- For connection of the **intrinsically safe electrode circuit including shield terminals** to the primary head, please refer to Item 12 in EN 60079-14. The non-intrinsically safe field circuit to be connected to the primary head in keeping with the requirements of Item 9 in EN 60079-14 .
- The **non-intrinsically safe input and output circuits** may only be routed into the hazardous area in compliance with appropriate measures as specified in EN 60079-14.
- **Supply power (terminals 11,12)**  
In conformity with current regulations for electrical installations, an isolating facility is required to be provided for the signal converter. The housing of the IFC 110 F – EEx signal converter must be incorporated in the equipotential bonding system (via external PA connection).

#### Note!

A PE safety conductor is not connected if a functional extra-low voltage with safety separation (PELV) is used. Grounding is then carried out by way of the equipotential bonding conductor.

- **Electrode circuit (terminals 1, 20, 2, 3, 30 and shield terminal S)**  
In conformity with the requirements for separation of intrinsically safe circuits, Category ib to EN 50 020, the cable for the intrinsically safe electrode circuit must, up to the terminals, be separated from all non-intrinsically safe circuits. Terminals 20 and 30 are optionally provided for connecting cables with single shielding. The terminal for the outer shield (S) is capacitance grounded in the signal converter. The outer overall shield to be connected by the shortest possible wire to the shield terminal. Shields to be carefully insulated from ground and from each other.
- **Field circuit FSV (terminals 7, 8)**  
The field circuit is all-pole protected on the FSV circuit board with an **internal fusible link 160mA / 250V**.
- **Input/output circuits**  
The connection is made to functional extra-low voltage circuits with safety separation (PELV). The I/O functions and technical data are described in the Standard Installation and Operating Instructions.



#### IMPORTANT!

For EEx versions, also pay regard to all directions included in Sect. 6.1 and 13. **Only the EEx flow sensor may be installed in the hazardous area. The EEx certified signal converter must be installed outside the hazardous area!**

- \* Do not remove the internal connection (cable) inside the terminal compartment of the signal converter (**yellow/green wire**) between the U-clamp terminal and terminal 10 (**protective conductor for protection class I instruments**).

Process temperature below 150°C (302°F)

I Signal cable A (type DS)

II Signal cable B (type BTS)

IFC 110 F V 2.0

IFC 110 F V 2.0

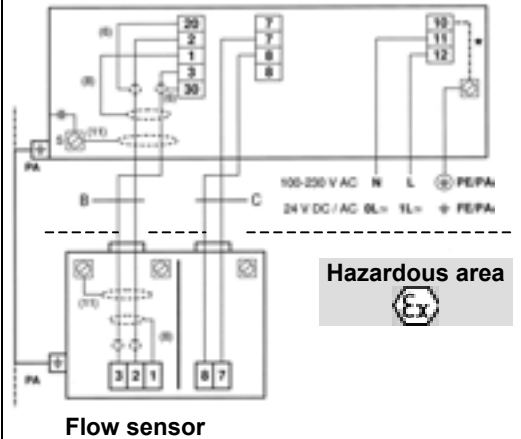
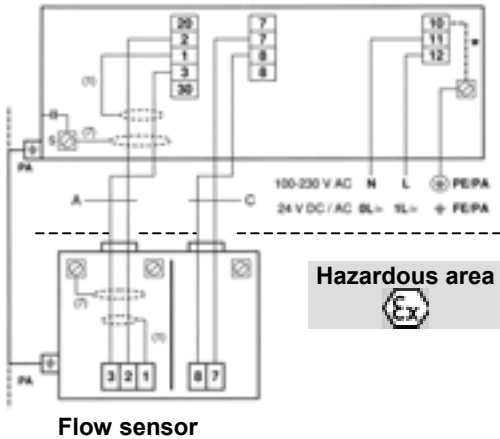

Process temperature above 150°C (302°F)

III Signal cable A (type DS)

IV Signal cable B (type BTS)

IFC 110 F V 2.0

IFC 110 F V 2.0

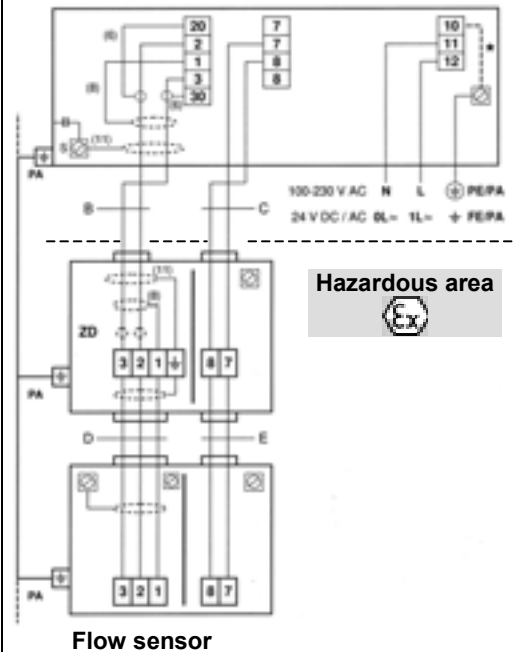
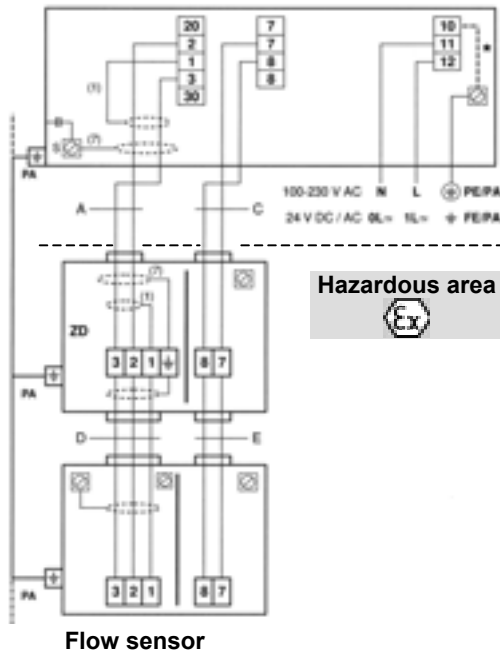

## 2 Electrical connection: outputs and inputs



### IMPORTANT!

For EEx versions, also pay regard to all directions included in Sect. 6.1 and 13.  
**Only the EEx flow sensor may be installed in the hazardous area. The EEx certified signal converter must be installed outside the hazardous area!**

### 2.1 Important information for outputs and inputs ..... PLEASE NOTE !

- The signal converter has the following **outputs and inputs**:

Output and input group	Symbol	Terminals	Remarks
Power output	I	I <sub>S</sub> / I	active / passive selectable
Current output	P	P / P	for electronic totalizers
Pulse output	A1* (P2)	A1* / A <sub>⊥</sub>	for electromechanical totalizers
Status outputs	A1* and A2	A1* / A <sub>⊥</sub> / A2	A <sub>⊥</sub> common centre grounding contact
Status outputs	D1 and D2	D1 / D <sub>⊥</sub> / D2	D <sub>⊥</sub> common centre grounding contact
Control inputs	C1 and C2	C1 / C <sub>⊥</sub> / C2	C <sub>⊥</sub> common centre grounding contact
Internal power supply	E	E+ / E-	for active mode of outputs and inputs

\* Output A1 can be used as a 2nd pulse output P2 for electromechanical totalizers or as a 4th status output, see Section 4.4, Fct. 3.07 HARDWARE.

- The output and input groups are electrically isolated from each other and from all other input and output circuits.
- Please note:**
  - A<sub>⊥</sub> common centre grounding contact for outputs **A1** and **A2**
  - D<sub>⊥</sub> common centre grounding contact for outputs **D1** and **D2**
  - C<sub>⊥</sub> common centre grounding contact for control inputs **C1** and **C2**
- Active mode:** the signal converter supplies the power for the operation (selection) of receiver instruments, observe max. operating data (terminals **E+** and **E-**).
- Passive mode:** the operation (selection) of receiver instruments requires an external power supply (**U<sub>ext</sub>**), observe max. operating data.
- Connection diagrams** of outputs and inputs are shown in **Section 2.6**.
- For **operating data** of outputs and inputs please refer to **Sections 2.6 and 10.1**.

## 2.2 Current output I

- The **current output is electrically isolated** from all other circuits.
- **Setting data and functions can note down in the Table in Sect. 3.**  
Please also refer to Section 2.7 "Standard factory settings".
- **All operating data and functions are adjustable** (see Sections 4.4 and 5.6, Fct. 1.05).
- **Max. load :** active operation 15-500  $\Omega$   
passive operation  $\leq 800 \Omega$
- **Selfcheck :** - interrupting the mA loop, and  
- short-circuit of mA loop via test function, see Fct. 2.03  
or when power supply is switched on in Fct. 3.07  
Error message on display (see Fct. 1.04, Section 5.4) and/or  
status output (see Fct. 1.07-1.10, Section 5.8).
- **Current value for error identification** is adjustable, see Fct. 1.05 and Section 5.6.
- **Range change-over**, automatically or externally by control input,  
see Sections 4.4 and 5.19, Fct. 1.07-1.10 and 1.11-12.  
Setting range from 5-80% of  $Q_{100\%}$   
(corresponding low to high range ratio from 1:20 to 1:1.25).  
Change-over from high to low range at approx. 85% of low range and vice versa at approx.  
98% of low range.  
The active range is signalled via one of the four status outputs.
- **Forward/reverse flow measurement** (F/R mode) is possible (see Section 5.15).
- **Connection diagrams see Section 2.6.**

## 2.3 Pulse outputs P and A1

### 2.3.1 Pulse output P for electronic totalizers (EC)

- **Pulse output P is electrically isolated** from all other circuits.
- **Setting data and functions can note down in the Table in Sect. 3.**  
Please also refer to Section 2.7 "Standard factory settings".
- **All operating data and functions are adjustable**, see Sections 4.4 and 5.7, Fct. 1.05.
- **Active mode:** uses the internal power supply, terminals E+/E-  
**Passive mode:** requires external power supply,  $U_{ext} \leq 32V$  DC/24V AC,  $I \leq 30mA$
- **Max. adjustable frequency 10 kHz**
- **Scaling** in pulses per unit time (e.g. 1000 pulses/s at  $Q_{100\%}$  flow) or in pulses per unit volume (e.g. 100 pulses/m<sup>3</sup> or US Gal).
- **Pulse width** symmetric, pulse duty factor 1:1, independent of output frequency, automatic, with optimum pulse width, pulse duty factor approx. 1:1 at  $Q_{100\%}$ , or pulse width range from 0.01 to 1 s adjustable as required for correspondingly lower output frequency.
- **Forward/reverse flow measurement (F/R mode)** is possible, see Section 5.15.
- **Connection diagrams see Section 2.6**
- **Schematic wiring diagram for pulse output P** for electronic totalizers **EC**  
Similar to a relay contact, this pulse output switches direct and alternating voltages.

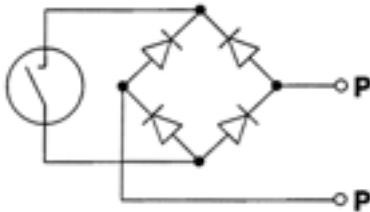



### 2.3.2 Pulse output A1 for electromechanical totalizers (EMC)

#### PLEASE NOTE:

The output terminal A1 can be used as status output A1 or as a 2nd pulse output A1 for electromechanical totalizers.

Setting is as described in Fct. 3.07 HARDWARE, see Sections 4.4 and 5.18.

- Pulse output A1 is electrically connected to status output A2 (common centre grounding contact A<sub>L</sub>) but electrically isolated from all other circuits.
- **Setting data and functions can note down in the Table in Sect. 3.**  
Please also refer to Section 2.7 "Standard factory settings".
- **All operating data and functions are adjustable**, see Sections 4.4 and 5.7, Fct. 1.07.
- **Active mode:** uses the internal power supply, terminals E+/E-
- **Passive mode:** requires external power supply,  $U_{\text{ext}} \leq 32\text{V DC}/24\text{V AC}$ ,  $I \leq 100\text{mA}$  ( $I \leq 200\text{mA}$  for polarized DC operation, see Section 6.3)
- **Max. adjustable frequency 50 kHz**
- **Scaling** in pulses per unit of time (e.g. 10 pulses/s at  $Q_{100\%}$  flow) or in pulses per unit of volume (e.g. 10 pulses/m<sup>3</sup> or US Gal).
- **Pulse width** symmetric, pulse duty factor 1:1, independent of output frequency, automatic, with optimum pulse width, pulse duty factor approx. 1:1 at  $Q_{100\%}$ , or pulse width range from 0.01 to 1 s adjustable as required for correspondingly lower output frequency.
- **Forward/reverse flow measurement (F/R mode)** is possible, see Section 5.15.
- **Connection diagrams see Section 2.6**
- **Schematic wiring diagram for pulse output A1** for electromechanical totalizers **EMC**.  
This pulse output has a MOSFET switch as output which switches direct and alternating voltages similar to a relay contact.

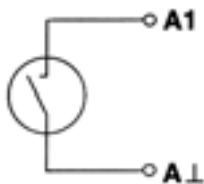

## 2.4 Status outputs A1 / A2 / D1 / D2

### PLEASE NOTE:

The output terminal A1 can be used as status output A1 or as a 2nd pulse output A1 for electromechanical totalizers.

Setting is as described in Fct. 3.07 HARDWARE, see Sections 4.4 and 5.18.

- **Status outputs A1/A2 and D1/D2** with the common centre grounding contacts A $\perp$  and B $\perp$  are **electrically isolated from each other and from all other circuits.**
- **Setting data and functions can note down in the Table in Sect. 3.**  
Please also refer to Section 2.7 "Standard factory settings".
- **All operating data and functions are adjustable**, see Sections 4.4 and 5.8, Fct. 1.07-1.10.
- **Active mode:** uses the internal power supply, terminals E+/E-  
**Passive mode:** requires external power supply,  $U_{ext} \leq 32V$  DC/24V AC,  $I \leq 100mA$   
( $I \leq 200mA$  for A1 in case of polarized DC operation, see Section 6.3)
- The **following operating conditions can be signalled** using the status outputs:
  - flow direction (F/R mode)
  - limits
  - error messages
  - active range in case of range change-over
  - inverse operation of A1 and A2 or D1 and D2,  
i.e. used as change-over switch with common centre grounding contact A $\perp$  or D $\perp$ .
- **Connection diagrams see Section 2.6**
- **Schematic wiring diagram for status outputs A1/A2 and D1/D2.**  
This status outputs have MOSFET switches as outputs which switch direct and alternating voltages similar to relay contacts.

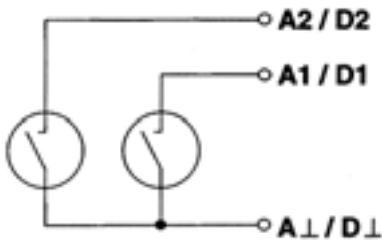

## 2.5 Control inputs C1 and C2

- **Control inputs C1 and C2 are electrically connected** (common centre grounding contact C $\perp$ ) but **electrically isolated from all other circuits.**
- **Setting data and functions can note down in the Table in Sect. 3.**  
Please also refer to Section 2.7 "Standard factory settings".
- **All operating data and functions are adjustable**, see Sections 4.4 and 5.9, Fct. 1.11-1.12.
- **Active mode:** uses the internal power supply, terminals E+/E-  
**Passive mode:** requires external power supply,  $U_{ext} \leq 32V$  DC/24V AC,  $I \leq 10mA$
- The **following operating conditions can be initiated** using the control inputs:
  - external range change
  - holding of output values
  - zeroing the outputs
  - resetting the internal totalizer
  - resetting (deleting) the error messages
- **Connection diagrams see Section 2.6**

## 2.6 Connection diagrams of outputs and inputs



**IMPORTANT!**

For EEx versions, also pay regard to all directions included in Sect. 6.1 and 13. **Only the EEx flow sensor may be installed in the hazardous area. The EEx certified signal converter must be installed outside the hazardous area!**

<b>I</b>	Current output (included HART®)	<b>Please note !</b> Unwired contacts or terminals may not have any conductive connection with other electrically conducting parts.
<b>P, A1*</b>	Pulse output	
<b>A1*, A2, D1, D2</b>	Status outputs	
<b>C1, C2</b>	Control inputs	<b>Interface operation with HART® or RS 485 (Option)</b> see Sect. 6.4.



**Totalizer**  
 -electromechanical (EMC)  
 - electronic (EC)

\* selectable as status output A1 or pulse output A1



**milliampmeter**  
 0-20 mA or 4-20 mA and other



Key, N/O contact



**External voltage source (U<sub>ext</sub>)**, DC or AC voltage, connection polarity arbitrary



**DC voltage**, external power source (U<sub>ext</sub>), note connection polarity

**Active mode:** the IFC 110 F supplies the power required for operating (driving) the receiver instruments. Observe the max. operating data (terminals **E+** and **E-**).

**Passive mode:** an external power supply source (U<sub>ext</sub>) is required for operating (driving) the receiver instruments.

Groups A / C / D / E / I / P are electrically isolated from each other and from all other input and output circuits.

**Please note:** common reference potential  
**A**⊥ for A1 and A2  
**C**⊥ for C1 and C2  
**D**⊥ for D1 and D2

① **Current output  $I_{active}$**

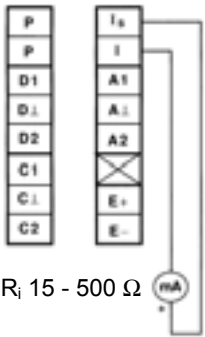

$R_i$  15 - 500  $\Omega$

② **Current output  $I_{active}$  with automatic range change BA**  
without external change-over relay

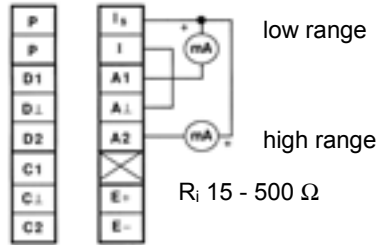

$R_i$  15 - 500  $\Omega$

③ **Current output  $I_{passive}$**   
(see Sect. 6.8 passive/active operation)

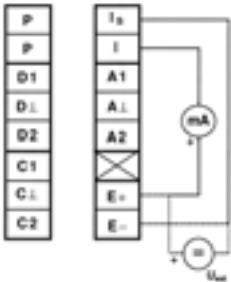

selectable with internal power supply **E** or external power supply **U<sub>ext.</sub>**

<b>U<sub>ext.</sub></b>	15 - 22 V DC	22 - 32 V DC
<b>R<sub>i</sub></b>	0 - 500 $\Omega$	0 - 800 $\Omega$

④ **Forward/reverse flow measurement (F/R mode)**  
for pulse and current outputs (P and  $I_{active}$ )  
without external change-over relay

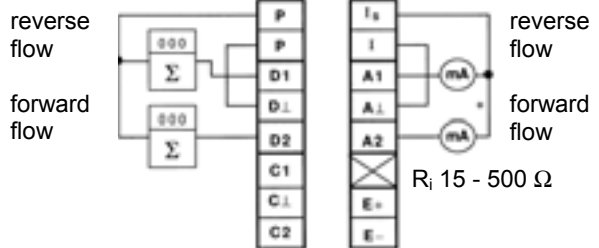

$R_i$  15 - 500  $\Omega$

**Electronic totalizers must be connected as shown in the connection diagrams for pulse output P on the following page.**

⑤ **Pulse output A1 active**  
for electromechanical totalizers (EMC)

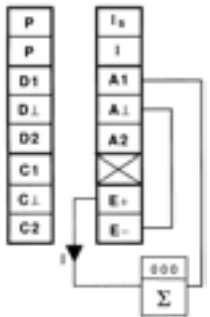

$R_i \geq 160 \Omega$   
 $I \leq 100 \text{ mA}$

⑥ **Pulse output A1 passive**  
for electromechanical totalizers (EMC)

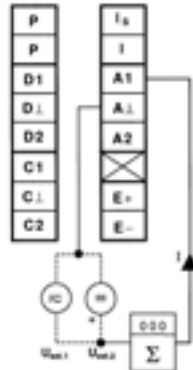

**U<sub>ext.</sub>  $\leq$  32 V DC /  $\leq$  24 V AC**  $I \leq 10 \text{ mA}$   
oder umschaltbar auf  
**U<sub>ext.2</sub>  $\leq$  32 V DC**  $I \leq 200 \text{ mA}$

⑦ **Pulse output  $P_{\text{active}}$**   
for electronic totalizers (EC)  
for frequencies  $\leq 1$  kHz

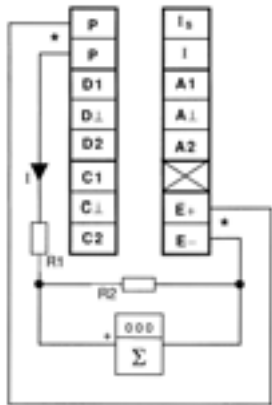

$R1 = 1 \text{ k}\Omega / 0.5 \text{ W}$     $I \leq 20 \text{ mA}$     $R_{I\text{EC}} > 100 \text{ k}\Omega$

$R2 / 0.2 \text{ W}$	10 k $\Omega$	1 k $\Omega$	270 $\Omega$
$U_{\text{EC max}}$	22 V	12 V	5 V

⑧ **Pulse output  $P_{\text{active}}$**   
for electronic totalizers (EC)  
for frequencies  $> 1$  kHz

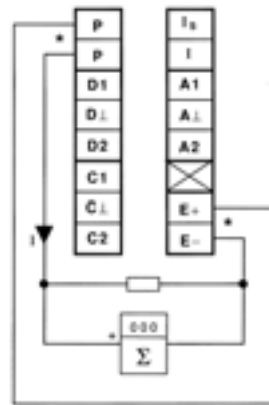

$R = 1 \text{ k}\Omega / 0.35 \text{ W}$     $I \leq 30 \text{ mA}$

⑨ **Pulse output  $P_{\text{passive}}$**   
for electronic totalizers (EC)

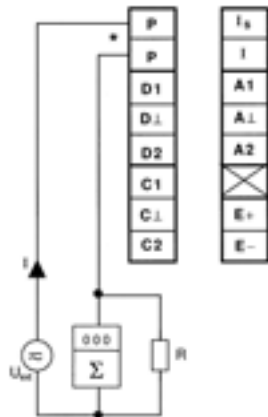

for frequencies  $\leq 1$  kHz

$U_{\text{ext}} \leq \leq 32 \text{ V DC} / \leq 24 \text{ V AC}$

$I \leq \leq 30 \text{ mA}$

$R = 1 - 10 \text{ k}\Omega$

$$P_R \geq \frac{U_{\text{ext}}^2}{R}$$

for frequencies  $> 1$  kHz

$U_{\text{ext}} = \leq 24 \text{ V DC} / \text{AC}$

$R_{I\text{EC}} \geq 100 \text{ k}\Omega$

$I$	$\sim 30 \text{ mA}$	$\sim 18 \text{ mA}$
$R$	560 $\Omega$	1 k $\Omega$
$P_R$	0.5 W	0.35 W
$U_{\text{EC}}$	16 V	18 V

\* **Shielded cables**

must be used to prevent radio interference at pulse output frequencies  $> 100$  Hz

⑩ Status outputs D1 / D2 / A1 / A2 active

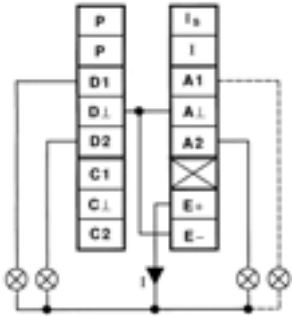

$I \leq 100 \text{ mA}$

⊗ e.g. message display

⑪ Status outputs D1 / D2 / A1 / A2 passive

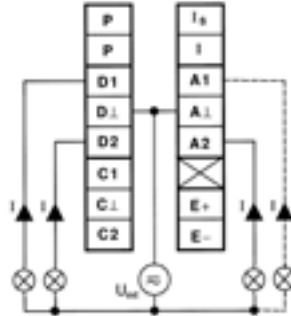

$U_{\text{ext.}} \leq 32 \text{ V DC} / \leq 24 \text{ V AC}$   
 $I \leq 100 \text{ mA}$

⊗ e.g. message display

⑫ Control inputs C1 / C2 active

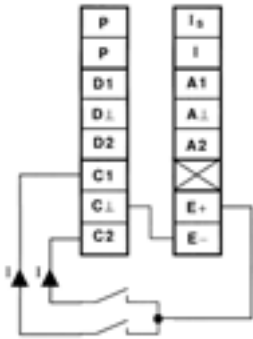

Contacts 24 V, 10 mA  
 $I \leq 7 \text{ mA}$

⑬ Control inputs C1 / C2 passive

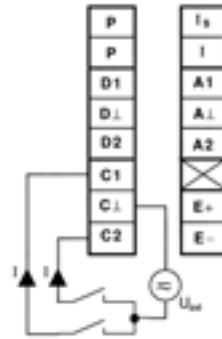

$U_{\text{ext.}} \leq 32 \text{ V DC} / \leq 24 \text{ V AC}$   
 $I \leq 10 \text{ mA}$

---

### 3 Start-up

---

- Before connecting to power, check that the instrument is correctly installed as described in Sections 1 and 2.
- The flowmeter, flow sensor and signal converter are delivered ready for operation. All operating data are set at the factory in accordance with your specifications.  
**Please also refer to Section 2.7 "Standard factory settings".**
- Switch on the power supply. The flowmeter immediately begins to measure the flow.
- When the power supply is switched on, the display successively shows **START UP** and **READY**. Then the current flow rate and/or the current totalizer count are displayed. Displays are either steady or cyclic depending on the setting described for Fct. 1.04.
- **2 light-emitting diodes (LED)** in the "diagnostics" field on the front panel of the signal converter indicate the status of measurement.

LED displays	Status of measurement
Green "normal" LED is flashing	Everything O.K.
Green "normal" LED and red "error" LED are flashing alternately	Momentary overload of outputs and/or A/D converter. Detailed error messages by setting Fct. 1.04 DISPLAY, subfunction "MESSAGES" to "YES", see Sections 4.4 and 5.5.
Red "error" LED is flashing	Fatal Error, see Sections 7.3 and 7.4



#### IMPORTANT!

For EEx versions, also pay regard to all directions included in Sect. 6.1 and 13.  
**Only the EEx flow sensor may be installed in the hazardous area. The EEx certified signal converter must be installed outside the hazardous area!**

## 4 Operating of the signal converter

### 4.1 KROHNE operating concept

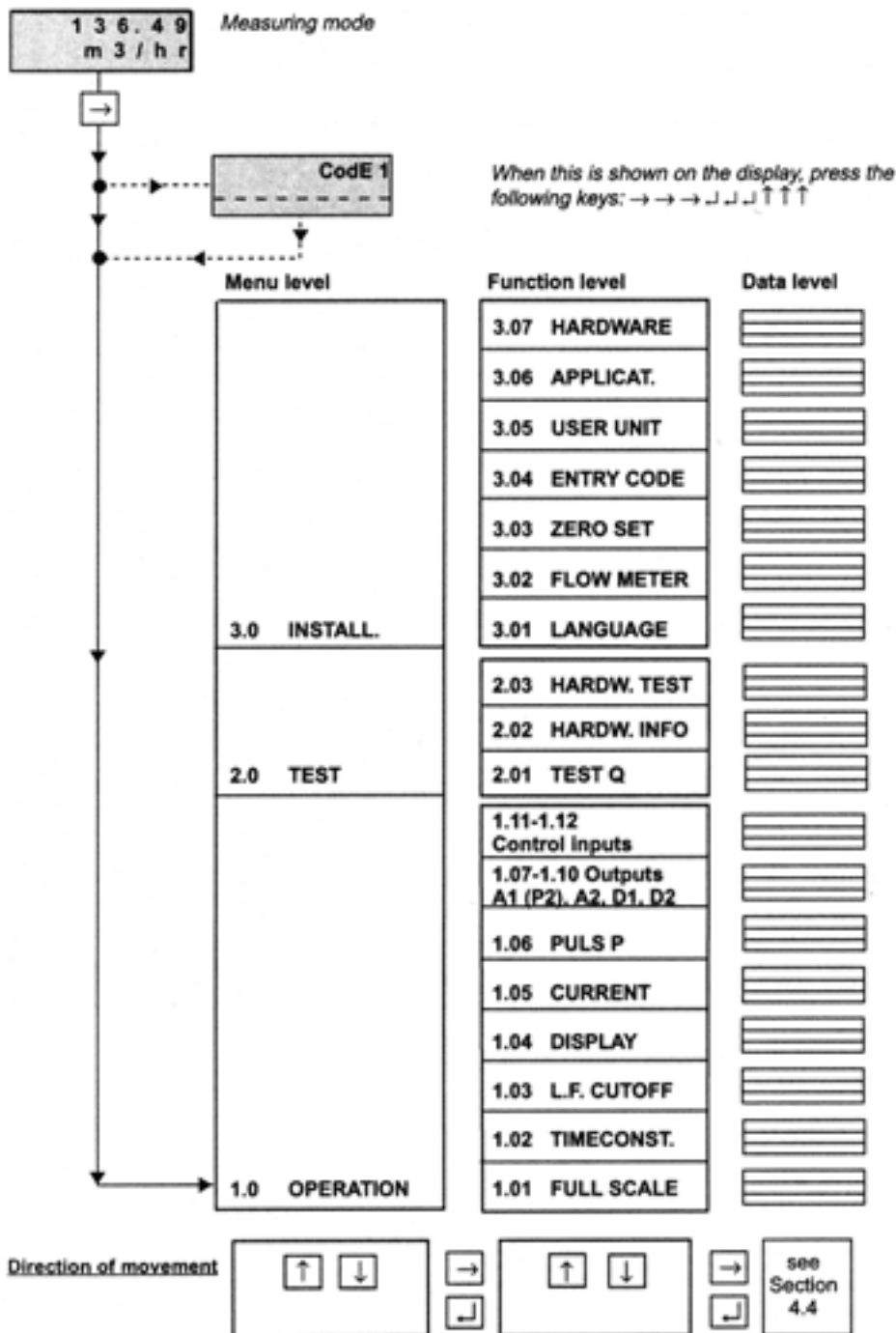



## 4.2 Operating and control elements

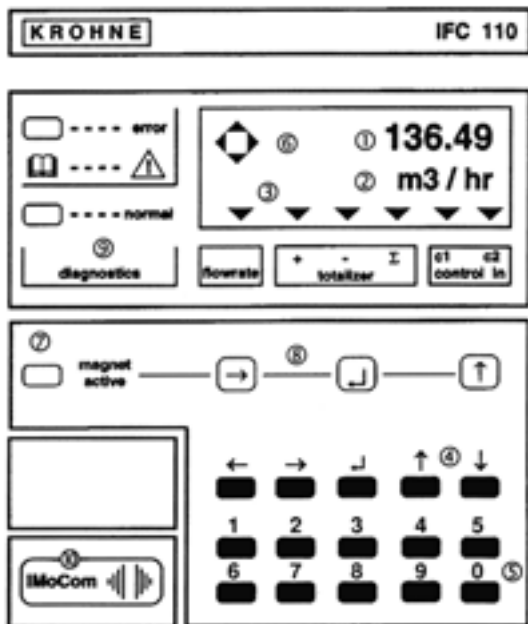

The instrument can be operated by means of ....

- ... the 15 keys ④ and ⑤ accessible after removal of the glass cover,
- ... the 3 magnetic sensors ⑧ and the bar magnet without opening the housing (optional).

- |  |   |
|--|---|
| ① Display, <u>1st line</u>   | Displaying numerical data   |
| ② Display, <u>2nd line</u>   | Displaying units and texts  |
| ③ Display, <u>3rd line</u>   | 6 arrows to mark the current display  |
| <b>flow rate</b>   | current flow rate   |
| <b>totalizer</b>   | + totalizer   |
|  | - totalizer   |
|  | Σ sum totalizer (+ and -)   |
| <b>control in</b>  | 1/2 control input 1 or 2 active   |
| ④ 5 keys for operating the signal converter ← → ↵ ↑ ↓  |   |
| ⑤ 10 keys for direct numerical setting of function values (not function numbers)   |   |
| ⑥ Compass field showing that a key is pressed  |   |
| ⑦ <b>magnet active</b>   | LED green/red, magnetic sensors active  |
|  | <u>green</u> = built-in magnetic sensors (optional), see ⑧  |
|  | <u>red</u> = operation of one of the 3 magnetic sensors   |
| ⑧ 3 magnetic sensors (optional), operated by bar magnet without opening the housing, function of the sensors as described for the three keys → ↵ ↑, see ④. |   |
| ⑨ <b>diagnostics</b>   | 2 LEDs signalling the status of measurement   |
| <i>normal</i>  | <u>green LED</u> = correct measurement, everything O.K.   |
| <i>error</i>   | <u>red LED</u> = error, parameter or hardware error   |
| ⑩ <b>IMoCom</b>  | IMoCom bus, multipoint connector for connecting external supplementary equipment, see Section 6.4, slide window to the left |

### 4.3 Key functions

In the following, the cursor or flashing part of the display is shown against a grey background.

#### To start operator control

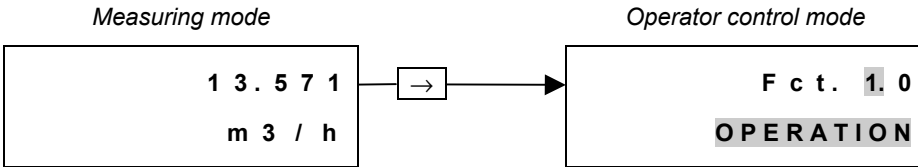

**PLEASE NOTE:** if "YES" is selected in **Fct. 3.04 ENTRY CODE**, "CodE 1 - - - - -" appears in the display after pressing the → key.

Enter the password for the entry code which is a sequence of 9 keys: → → → ↵ ↵ ↵ ↑ ↑ ↑ (each keystroke confirmed by " \* ").

#### To terminate operator control

Press key ↵ any number of times until one of the following menus **Fct. 1.0 OPERATION**, **Fct. 2.0 TEST** or **Fct. 3.0 INSTALL** is displayed.

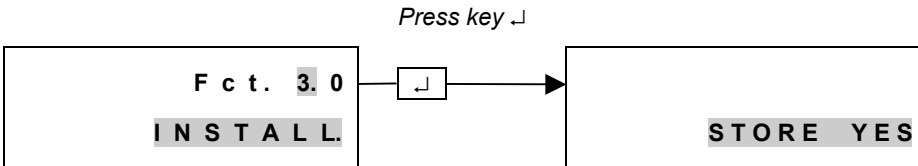

**Store new parameters:** acknowledge by pressing key ↵. Measuring mode is continued with new parameters.

**New parameters not to be stored:**  
press key ↑ to display "STORE NO".  
Measuring mode is continued with the "old" parameters after pressing key ↵.

#### Keyboard with 10 keys

The keyboard with the 10 keys (0-9) is used for **setting all flashing numbers (cursor)**.

**Exception:** the digits of the function numbers, such as **Fct. 1.03**, can only be changed with keys ↑ or ↓.

### To change numbers

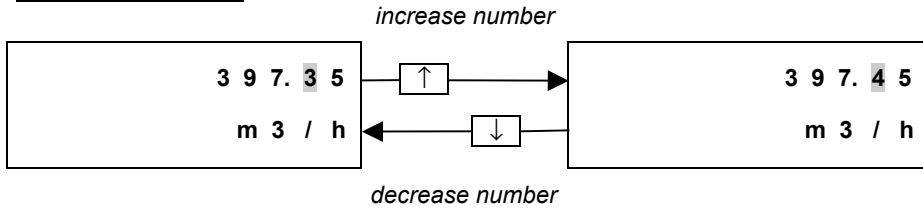

### To shift cursor (flashing position)

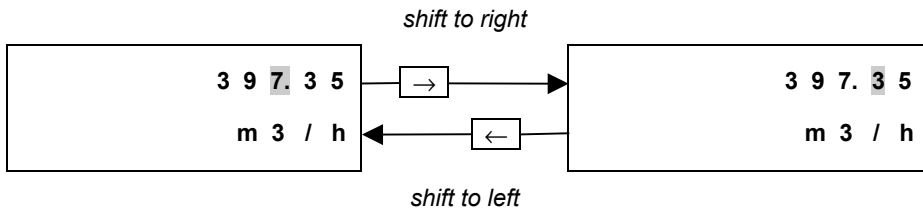

### To alter texts (units)

In case of units, the numerical value is converted automatically.

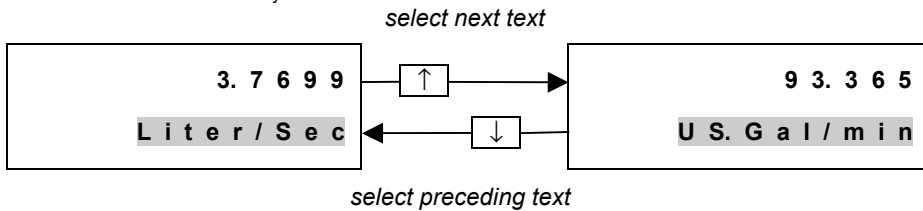

### To change from text (unit) to numerical setting

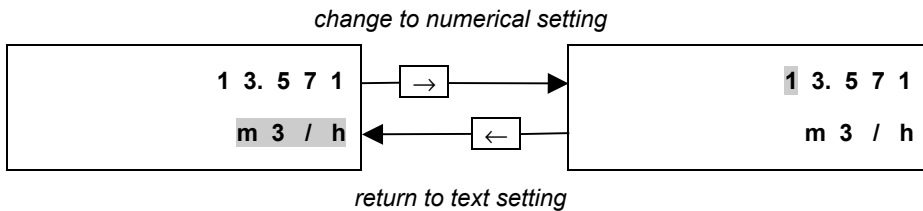

### To change to subfunction

Subfunctions have no "Fct. No." and are identified by a "→"

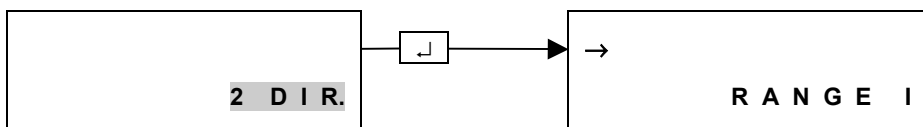

### To revert to function display

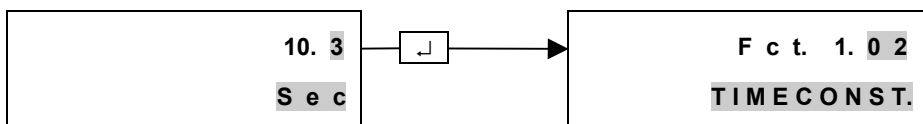

## 4.4 Table of settable functions

### Abbreviations used:

**A1, A2** Status outputs  
(A1 can also be 2nd pulse output A1)

**C1, C2** Control inputs

**D1, D2** Status outputs

**DN** Meter size, nominal size

**F<sub>max</sub>** = ½ x pulse width (s) for ≤ 50 Hz  
≤ 10 kHz if "AUTO" or "SYM." are selected in subfunction "PULSWIDTH"  
= 10 pulses/h

**F<sub>min</sub>**

**F<sub>M</sub>** Conversion factor volume for any unit, see Fct. 3.05 "FACT. VOL."

**F<sub>T</sub>** Conversion factor time for any unit, see Fct. 3.05 "FACT. TIME"

**GK** Flow sensor constant

**I** Current output

**I<sub>0%</sub>** Current at 0% flow rate

**I<sub>100%</sub>** Current at 100% flow rate

**P (P2)** Pulse output (2nd pulse output A1)

**P<sub>max</sub>** =  $F_{max}/Q_{100\%}$

**P<sub>min</sub>** =  $F_{min}/Q_{100\%}$

**Q** Current flow rate

**Q<sub>100%</sub>** 100% flow rate = full-scale range

**Q<sub>max</sub>** =  $\frac{\pi}{4} DN^2 \times v_{max}$  (= max. full-scale range)  
Q<sub>100%</sub> at v<sub>max</sub> = 12 m/s or 40 ft/s)

**Q<sub>min</sub>** =  $\frac{\pi}{4} DN^2 \times v_{min}$  (= min. full-scale range)  
Q<sub>100%</sub> at v<sub>min</sub> = 0.3 m/s or 1 ft/s)

**SMU** Low-flow cutoff for I and P

**v** Flow velocity

**v<sub>max</sub>** Maximum flow velocity (12 m/s or 40 ft/s) at Q<sub>100%</sub>

**v<sub>min</sub>** Minimum flow velocity (0.3 m/s or 1 ft/s) at Q<sub>100%</sub>

**F/R** Forward/reverse flow in F/R measuring mode

Fct.	Text	Description and setting
1.0	<b>OPERATION</b>	<b>Operating menu</b>
	<b>FULL SCALE</b>	<p><b>Full-scale range for flow rate Q<sub>100%</sub></b></p> <p><u>Selection of unit</u></p> <ul style="list-style-type: none"> <li>• m<sup>3</sup>/h</li> <li>• Liter/Sec</li> <li>• US.Gal/min</li> </ul> <p>• user unit, factory setting "Liter/h" or "US MGal/day" (see Fct. 3.05)</p> <p>Press → key to change to numerical setting</p> <p><u>Setting ranges</u></p> <p>The range depends on the nominal width (DN) and the</p> <p>flow velocity (v):</p> $Q_{min} = \frac{\pi}{4} DN^2 \times v_{min} \qquad Q_{max} = \frac{\pi}{4} DN^2 \times v_{max}$ <p><u>Nominal width/meter size</u>      <math>v_{min} = 0.3 \text{ m/s (1 ft/s)}</math>      <math>v_{max} = 12 \text{ m/s (40 ft/s)}</math></p> <ul style="list-style-type: none"> <li>• DN 2.5–1200 / 1/10"–48":      0.0053      –      48 860 m<sup>3</sup>/h</li> <li>   0.0237      –      218 560 US.Gal/min</li> <li>• DN 1300–3000 / 52"–120"    1435      –      305 360 m<sup>3</sup>/h</li> <li>   (see Section 8.6)      6415      –      1 366 000 US.Gal/min</li> </ul> <p>Press ↵ key to return to Fct. 1.01 FULL SCALE</p>
	→ VALUE P and/or → VALUE P2	<p><b>Pulse value for pulse output P (Fct. 1.06 "VALUE P") and/or for the 2nd pulse output A1 (Fct. 1.07 "VALUE P2") has been changed.</b></p> <p>With the "old" pulse values the output frequency (F) would have been exceeded or would not have been reached.</p> <p><b>P<sub>min</sub> = F<sub>min</sub> / Q<sub>100%</sub>      P<sub>max</sub> = F<sub>max</sub> / Q<sub>100%</sub>      <b>Check new values!</b></b></p>
1.02	<b>TIMECONST.</b>	<p><b>Time constant</b></p> <p><u>Selection:</u></p> <ul style="list-style-type: none"> <li>• ALL (applies to display and all outputs)</li> <li>• ONLY I (only display, current and status outputs)</li> </ul> <p>Press ↵ key to change to numerical setting.</p> <p><u>Range:</u></p> <ul style="list-style-type: none"> <li>• 0.2 – 99.9 Sec</li> </ul> <p>Press ↵ key to return to Fct. 1.02 TIMECONST.</p>
1.03	<b>L.F. CUTOFF</b>	<p><b>Low-flow cutoff (L.F. CUTOFF)</b></p> <ul style="list-style-type: none"> <li>• OFF (fixed tripping points: ON = 0.1% / OFF = 0.2%)</li> <li>• PERCENT (variable tripping points)</li> </ul> <p style="margin-left: 300px;">ON                  OFF</p> <p style="margin-left: 300px;">1 – 19%                 2 – 20%</p> <p>Press → key to change to numerical setting.</p> <p><u>Note:</u> the cutoff "OFF" value must be greater than the cutoff "ON" value.</p> <p>Press ↵ key to return to Fct. 1.03 L.F. CUTOFF.</p>

Fct.	Text	Description and setting
1.04	<b>DISPLAY</b>	<b>Display functions</b>
	→ <b>DISP.FLOW</b>	<b>Selection of flow display</b> <ul style="list-style-type: none"> <li>NO DISP.</li> <li>m³/h</li> <li>Liter/Sec</li> <li>US.Gal/min</li> <li>User unit, factory setting "Liter/h" or "US MGal/day" (s. Sect. 3.05)</li> <li>PERCENT</li> <li>BARGRAPH (value and bar graph display in %)</li> </ul> <i>Press ↵ key to change to subfunction "DISP. TOTAL."</i>
	→ <b>DISP.TOTAL.</b>	<b>Selection of totalizer display</b> <ul style="list-style-type: none"> <li>NO DISP. (totalizer is ON but no display)</li> <li>OFF (totalizer is OFF)</li> <li>+ TOTAL.</li> <li>- TOTAL.</li> <li>+/- TOTAL.</li> <li>SUM (Σ)</li> <li>ALL (display single counts or all)</li> </ul> <i>Press ↵ key to change to setting of display unit.</i> <p>-----</p> <ul style="list-style-type: none"> <li>m³</li> <li>Liter</li> <li>US.Gal</li> </ul> <ul style="list-style-type: none"> <li>User unit, factory setting "Liter" (s. Sect. 3.05)</li> </ul> <i>Press → key to transfer to format setting.</i> <p>-----</p> <b>Format setting</b> <ul style="list-style-type: none"> <li>Auto (exponent notation)</li> <li># . #####</li> <li>## . #####</li> <li>### . #####</li> <li>#### . #####</li> <li>##### . ###</li> <li>##### . ##</li> <li>##### . #</li> <li>#####</li> </ul> <i>Press ↵ key to change to subfunction "DISP. MSG."</i>
	→ <b>DISP.MSG.</b>	<b>Additional messages desired during measuring mode?</b> <ul style="list-style-type: none"> <li>NO</li> <li>YES (cyclic change with display of measured values)</li> </ul> <i>Press ↵ key to return to Fct. 1.04 DISPLAY.</i>
1.05	<b>CURRENT I</b>	<b>Current output I</b>
	→ <b>FUNCT. I</b>	<b>Selecting the current output I function</b> <ul style="list-style-type: none"> <li>OFF (switched off)</li> <li>+ DIR.</li> <li>- DIR. (measurement in one flow direction only)</li> <li>2 DIR. (forward/reverse flow, F/R mode)</li> </ul> <i>Press ↵ key to change to subfunction "RANGE I"; if "2 DIR." is selected press this key to change to subfunction "REV. RANGE".</i>
	→ <b>REV.RANGE</b>	<b>Setting the full-scale range for reverse flow of Q<sub>100%</sub></b> (only displayed when "2 DIR." is selected) <ul style="list-style-type: none"> <li>100 PCT. (same as forward flow Q<sub>100%</sub>; see Sect. 1.01)</li> <li>PERCENT <u>setting range</u>: 005 - 150 % of Q<sub>100%</sub> (different value for reverse flow)</li> </ul> <i>Press → key to change to numerical setting.</i> <i>Press ↵ key to change to subfunction "RANGE I"</i>
	→ <b>RANGE I</b>	<b>Selecting the measuring range</b> <ul style="list-style-type: none"> <li>0 - 20 mA</li> <li>4 - 20 mA (fixed ranges)</li> <li>mA (user-defined range)</li> </ul> $\frac{I_{0\%}}{0 - 16 \text{ mA}} - \frac{I_{100\%}}{4 - 20 \text{ mA}}$ (Value I <sub>0%</sub> < I <sub>100%</sub> !) <p><i>Press → key to change to numerical setting!</i></p> <i>Press ↵ key to change to subfunction "I ERROR".</i>
	→ <b>I ERROR</b>	<b>Selecting the error value</b> <ul style="list-style-type: none"> <li>22 mA</li> <li>0.0 to I<sub>0%</sub> mA (variable when I<sub>0%</sub> ≥ 1 mA, see above)</li> </ul> <i>Press → key to change to numerical setting.</i> <i>Press ↵ key to return to Fct. 1.05 "CURRENT OUTPUT I".</i>
1.06	<b>PULS P</b>	<b>Pulse output P</b> Description of function of pulse output P on the next page.
1.07	<b>STATUS A1</b> or <b>PULS2 A1</b>	<b>Status output A1</b> } <b>A1 = terminal</b> } connected as status or pulse output (P2) <b>2nd pulse output A1</b> } s. Fct. 3.07 HARDWARE, "Terminal A1" Description of function of status output A1 or 2nd pulse output A1 on the next page.

Fct.	Text	Description and setting
1.08	STATUS A2	} <b>Status outputs A2, D1 and D2</b> Description of function of status outputs A2, D1 and D2 on the next page but one.
1.09	STATUS D1	
1.10	STATUS D2	
1.11	CONTROL C1	} <b>Control inputs C1 and C2</b> Description of function of control inputs on the next page but one.
1.12	CONTROL C2	
1.06	PULS P	<b>Pulse output P</b> for electronic totalizers up to 10,000 pulses/s
1.07	PULS2 A1	<b>2nd pulse output A1</b> for electromechanical totalizers up to max. 50 Hz. Connection of terminal A1 as a 2nd pulse output A1 or as status output A1, see Fct. 3.07 HARDWARE, "Terminal A1".
Fct. 1.06 and 1.07 have identical menus and are configured in accordance with the same setting mode.	→ FUNCT. P → FUNCT. P2	<b>Selecting the function for pulse outputs P and P2</b> <ul style="list-style-type: none"> <li>• OFF</li> <li>• + DIR.                      • - DIR. (measuring in one flow direction only)</li> <li>• 2 DIR. (forward/reverse flow, F/R mode)</li> </ul> <i>Press ↵ key to change to subfunction "SELECT P or P2".</i>
	→ SELECT P → SELECT P2	<b>Selecting the type of pulse</b> <ul style="list-style-type: none"> <li>• PULSE/VOL. (pulses per unit volume, flow rate)</li> <li>• PULSE/TIME (pulses per unit time for 100% flow rate)</li> </ul> <i>Press ↵ key to change to subfunction "PULSWIDTH".</i>
	→ PULSWIDTH → PULSWIDTH	<b>Selecting the pulse width</b> <ul style="list-style-type: none"> <li>• 0.01 - 1.00 s (only for <math>F_{max} &lt; 50</math> pulses/s)</li> <li>• AUTO (automatic = 50% of cycle duration of 100% output frequency)</li> <li>• SYM (symmetric = pulse duty factor approx. 1:1 across the entire range)</li> </ul> <i>Press ↵ key to change to subfunction "VALUE P or P2".</i>
	→ VALUE P → VALUE P2	<b>Setting the pulse value per unit volume</b> (only displayed when "PULSE/VOL." is selected in "SELECT P or P2" above). <ul style="list-style-type: none"> <li>• xxxx PulS/m<sup>3</sup>                      • xxxx PulS/Liter                      • xxxx PulS/US.Gal</li> <li>• xxxx PulS/user unit, factory setting "Liter" or "US MGal" (s. Fct. 3.05)</li> </ul> Setting range "xxxx" depends on pulse width and full-scale range: $P_{min} = F_{min} / Q_{100\%}$ , $P_{max} = F_{max} / Q_{100\%}$ <i>Press ↵ key to return to Fct. 1.06 PULS P or Fct. 1.07 PULS2 A1.</i>
	→ VALUE P → VALUE P2	<b>Setting the pulse value per unit time</b> (only displayed when "PULSE/TIME" is selected in "SELECT P or P2" above). <ul style="list-style-type: none"> <li>• xxxx PulSe/Sec (=Hz)                      • xxxx PulSe/min                      • xxxx PulSe/h</li> <li>• xxxx PulSe/user unit, factory setting "h" (s. Fct. 3.05)</li> </ul> Setting range "xxxx" depends on pulse width (see above). <i>Press ↵ key to return to Fct. 1.06 PULS P or Fct. 1.07 PULS2 A1.</i>

Fct.	Text	Description and setting
1.07	STATUS A1	Status output A1 (terminal A1 connected as status output A1 or as a 2nd pulse output A1, see Fct. 3.07 HARDWARE, "terminal A1")
1.08	STATUS A2	Status output A2
1.09	STATUS D1	Status output D1
1.10	STATUS D2	Status output D2
	→ Fct. 1.07 to 1.10 are configured in accordance with the same setting mode. Functions set for one of the status outputs are no longer available for the other status outputs.	<ul style="list-style-type: none"> <li>• OFF                      • ON                      • ALL ERROR                      • FATAL.ERROR</li> <li>• INVERS D1 (inverse mode of D1 and D2)</li> <li>• INVERS A1 (inverse mode of A1 and A2 possible only if A1 is operated as status output, see Fct. 3.07 HARDWARE, "terminal A1")</li> <li>• SIGN I, P or P2 (F/R mode)                      } <b>dynamic behaviour</b> of outputs see Fct. 1.02</li> <li>• OVERFL. I, P or P2 (overloading the outputs)                      } TIMECONST.: I = ONLY I P or P2 = ALL</li> <li>• EMPTY PIPE ("tube empty" signal only with built-in option)</li> <li>• TRIP. POINT <i>Press → key to change to character.</i> <b>Selection:</b>                      • + DIR.                      • - DIR.                      • 2 DIR. <i>Press ↓ key to change to numerical setting.</i> <b>Setting range:</b> 000 - 150 PERCENT</li> <li>• AUTO. RNG.                      <b>Setting range:</b> 05-80 PERCENT (= lower to upper range ratio 1:20 to 1:1.25, value must be higher than that of Fct. 1.03 L.F. CUTOFF) <i>Press ↓ key to change to numerical setting.</i> <i>Press ↓ key to return to Fct. 1.06, 1.07, 1.08 or 1.09.</i></li> </ul>
Fct.	Text	Description and setting
1.11	CONTROL C1	Control input C1 and C2
1.12	CONTROL C2	<ul style="list-style-type: none"> <li>• OFF                      • EXT. RNG. (external range change) <b>Setting range:</b> 05-80 PERCENT (= lower to upper range ratio 1:20 to 1:1.25, value must be higher than that of Fct. 1.03 L.F. CUTOFF) <i>Press ↓ key to change to numerical setting.</i></li> <li>• OUTP. HOLD (hold output values)</li> <li>• OUTP. ZERO (set outputs to "min. values")</li> <li>• TOTAL.RESET (reset the totalizer)</li> <li>• ERROR.RESET (delete error messages) <i>Press ↓ key to return to Fct. 1.11 or 1.12 CONTROL C1 or C2</i></li> </ul>
	→	
Fct.	Text	Description and setting
2.0	TEST	Test menu
	TEST Q	<b>Test measuring range Q</b> <u>Precautionary query</u> <ul style="list-style-type: none"> <li>• SURE NO                      <i>Press ↓ key to return to Fct. 2.01 "TEST Q".</i></li> <li>• SURE YES                      <i>Press ↓ key, then use ↑ key to</i> <i>select value:</i>                      -110 / -100 / -50 / -10 / 0 / +10 / +50 / +100 / +110 PCT. of set full-scale range Q<sub>100%</sub>. Displayed value is available at outputs I and P. <i>Press ↓ key to return to Fct. 2.01 "TEST Q".</i></li> </ul>
2.02	HARDW. INFO	<b>Hardware information and error status</b> Before consulting factory, please note down all 6 codes.
	→ MODUL ADC	X . X X X X X . X X Y Y Y Y Y Y Y Y Y Y <i>Press ↓ key to transfer to "MODUL IO".</i>
	→ MODUL IO	X . X X X X X . X X Y Y Y Y Y Y Y Y Y Y <i>Press ↓ key to transfer to "MODUL DISP.".</i>
	→ MODUL DISP.	X . X X X X X . X X Y Y Y Y Y Y Y Y Y Y <i>Press ↓ key to return to</i> Fct. 2.02 "HARDW. INFO".
2.03	HARDW. TEST	<b>Hardware test</b> (Precautionary query) - SURE NO <i>Press ↓ key to return to Fct. 2.03 "HARDW. TEST".</i> - SURE YES <i>Press ↓ key to start test, duration approx. 60 s</i> If errors are found, the first one is displayed. Press ↓ key to display next error. List of errors see Section 4.5. <i>Press ↓ key to return to Fct. 2.03 "HARDW. TEST".</i>

Fct.	Text	Description and setting
3.0	INSTALL.	Installation menu
3.01	LANGUAGE	<p><b>Select language for display texts</b></p> <ul style="list-style-type: none"> <li>● GB / USA (English)</li> <li>● D (German)</li> <li>● F (French)</li> <li>● S (Swedish)</li> <li>● other languages on request</li> </ul> <p>Press <math>\downarrow</math> key to return to Fct. 3.01 "LANGUAGE".</p>
3.02	FLOWMETER	<p><b>Set data for flow sensor</b></p> <p>→ DIAMETER <b>Select size from meter size table</b></p> <ul style="list-style-type: none"> <li>● DN 2.5 - 1200 mm equivalent to 1/10 - 48 inch</li> <li>● DN 1300 - 3000 mm equivalent to 52 - 120 inch (see Sect. 8.6)</li> </ul> <p>Select with <math>\uparrow</math> key. Press <math>\downarrow</math> key to change to subfunction "FULL SCALE".</p> <p>→ FULL SCALE <b>Full-scale range for flow <math>Q_{100\%}</math></b> To set, refer to Fct. 1.01 "FULL SCALE". Press <math>\downarrow</math> key to change to subfunction "GK VALUE".</p> <p>→ VALUE P and/or → VALUE P <b>Pulse value for pulse output P (Fct. 1.06 "VALUE P") and/or for the 2nd pulse output A1 (Fct. 1.07 "VALUE P2") has been changed.</b> With the "old" pulse values the output frequency (F) would have been exceeded or would not have been reached. <math>P_{min} = F_{min} / Q_{100\%}</math>    <math>P_{max} = F_{max} / Q_{100\%}</math>    <b>Check new value.</b></p> <p>→ GK VALUE <b>Set primary constant GK</b> See instrument nameplate of flow sensor. Range:    ● 1.0000 - 15.000 Press <math>\downarrow</math> key to change to subfunction "FIELD. FREQ.".</p> <p>→ FIELD FREQ. <b>Magnetic field frequency</b> Values: <math>1/2</math>, <math>1/6</math>, <math>1/18</math> and <math>1/36</math> of power frequency, see instr. nameplate. Press <math>\downarrow</math> key to change to subfunction "FLOW DIR."; on DC instruments change to subfunction "LINE FREQ.".</p> <p>→ LINE FREQ. <b>Power frequency customary in the country where the instrument is used</b> <u>Please note:</u> this function is limited to instruments with DC supply unit (24 V DC) to suppress line frequency interferences. Values: <u>50 Hz</u> and <u>60 Hz</u> Press <math>\downarrow</math> key change to subfunction "FLOW DIR.".</p> <p>→ FLOW DIR. <b>Define flow direction</b> (in F/R mode: forward flow). Set according to direction of arrow on flow sensor: ● + DIR.                      ● - DIR.    <i>Select using <math>\uparrow</math> key.</i> Press <math>\downarrow</math> key to return to Fct. 3.02 "FLOWMETER".</p>
3.03	ZERO SET	<p><b>Zero calibration</b></p> <p><u>Note:</u> carry out only at "0" flow and with completely filled measuring tube! <u>Precautionary query</u></p> <ul style="list-style-type: none"> <li>● CALIB. NO    Press <math>\downarrow</math> key to return to Fct. 3.3 "ZERO SET".</li> <li>● CALIB. YES    Press <math>\downarrow</math> key to start calibration.</li> </ul> <p>Duration approx. 15-90 s (depending on magnetic field frequency), current flow rate displayed in the selected unit (s. Fct. 1.04 "DISP. FLOW").</p> <p>A "WARNING" sign appears when flow rate "&gt;0"; acknowledge by pressing <math>\downarrow</math> key.</p> <ul style="list-style-type: none"> <li>● STORE NO    (do <b>not</b> store new zero value)</li> <li>● STORE YES    (store new zero value)</li> </ul> <p>Press <math>\downarrow</math> key to return to Fct. 3.03 "ZERO SET".</p>
3.04	ENTRY CODE	<p><b>Entry code required to enter setting mode?</b></p> <ul style="list-style-type: none"> <li>● NO    (= entry with <math>\rightarrow</math> only)</li> <li>● YES    (= entry with <math>\rightarrow</math> and Code 1: <math>\rightarrow \rightarrow \rightarrow \downarrow \downarrow \downarrow \uparrow \uparrow \uparrow</math>)</li> </ul> <p>Press <math>\downarrow</math> to return to Fct. 3.04 "ENTRY CODE".</p>



Fct.	Text	Description and setting
3.05	<b>USER UNIT</b>	<b>Set any required unit for flowrate and counting</b>
	→ <b>TEXT VOL.</b>	<b>Set text for required flowrate unit</b> (max. 5 characters) Factory setting = Liter or US MGal <u>Characters which can be assigned to each place:</u> • A-Z, a-z, 0-9, or " " (= blank character). <i>Press ↵ key to transfer to subfunction "FACT. VOL."</i>
	→ <b>FACT. VOL.</b>	<b>Set conversion factor (<math>F_M</math>) for volume</b> Factory setting "1.00000 E+3" for "Liter" or "2.64172E-4" for "US MGal" (exponent notation, here $10^3$ or $2.64172 \times 10^{-4}$ ) <u>Factor <math>F_M</math> = volume per <math>1m^3</math>.</u> <u>Setting range</u> • 1.00000 E-9 to 9.99999 E+9 (= $10^{-9}$ to $10^{+9}$ ) <i>Press ↵ key to transfer to subfunction "TEXT TIME".</i>
	→ <b>TEXT TIME</b>	<b>Set text for any time</b> (max. 3 characters) Factory setting = "h" (hours) <u>Characters which can be assigned to each space:</u> • A-Z, a-z, 0-9, or " " (= blank character). <i>Press ↵ key to transfer to subfunction "FACT. TIME"</i>
→ <b>FACT. TIME</b>	<b>Set conversion factor (<math>F_T</math>) for time</b> Factory setting "3.60000 E+3" for "h" (exponent notation, here $3.3 \times 10^3$ ). Set <u>factor <math>F_T</math></u> in seconds. <u>Setting range</u> • 1.00000 E-9 to 9.99999 E+9 (= $10^{-9}$ to $10^{+9}$ ) <i>Press ↵ key to return to Fct. 3.05 "USER UNIT".</i>	
3.06	<b>APPLICAT.</b> → <b>FLOW</b>	<b>Set modulation range of A/D converter</b> • STEADY (150% of $Q_{100\%}$ )      • PULSATING (1000% of $Q_{100\%}$ ) <i>Press ↵ key to change to subfunction "EMPTY PIPE".</i>
	<b>EMPTY PIPE</b>	<b>Empty pipe detection EPD</b> (see Sect. 6.9) • NO (Press ↵ key to change to subfunction "ADC Gain") • YES (Press ↵ key to change to "VAL. FULL") • VAL. FULL (Press ↵ key, precautionary query) • CALIB. NO (Press ↵ key to change to "VAL. EMPTY") • CALIB. YES (Press ↵ key, calibration will start with flashing display "WAIT", duration approx. 20 seconds) Make sure that measuring tube is completely filled! • STORE NO (Press ↵ key to change to "VAL. EMPTY") • STORE YES (Press ↵ key to change to "VAL. EMPTY") • VAL. EMPTY (Press ↵ key, precautionary query) • CALIB. NO (Press ↵ key to change to "VAL. EMPTY") • CALIB. YES (Press ↵ key, calibration will start with flashing display "WAIT", duration approx. 20 seconds) Make sure that measuring tube is completely empty! • STORE NO (Press ↵ key to change to subfunction "ADC GAIN") • STORE YES (Press ↵ key to change to subfunction "ADC GAIN") <b>Please Note:</b> The values of the measured impedances must be in range 0 - 150. The difference of the value VAL. EMPTY must be 10 greater than the value of VAL. FULL!
	→ <b>ADC GAIN</b>	<b>Set gain of A/D converter</b> • AUTO      • 10      • 30      • 100      Select with key ↑ or ↓ <i>Press ↵ key to change to subfunction "SPEC. FILT."</i>
	→ <b>SPEC. FILT.</b>	<b>Activate special filter for noise/interference suppression?</b> PLEASE NOTE information and examples given in Sect. 6.6. • NO (Press ↵ key to change to Fct. 3.06 "APPLICAT.") • YES (Press ↵ key to change to subfunction "LIMIT VAL.")

Fct.	Text	Description and setting
	→ LIMIT VAL.	<b>Set limit value for noise/interference suppression</b> (appears only when "YES" is selected under "SPEC. FILT.", see above) <u>Setting range:</u> 01-90 PERCENT of full-scale range $Q_{100\%}$ see Fct. 3.02, subfunction "FULL SCALE" <i>Press ↵ key to change to subfunction "LIMIT CNT."</i>
	→ LIMIT CNT.	<b>Totalizer active when exceeding limit value</b> (see "LIMIT VAL." above) (appears only when "YES" is selected under "SPEC. FILT.") <u>Setting range:</u> 001-250 <i>Press ↵ key to return to Fct. 3.06 "APPLICAT."</i>
<b>3.07</b>	<b>HARDWARE</b>	<b>Determine HARDWARE functions</b>
	→ TERM.A1	<b>Terminal A1</b> <ul style="list-style-type: none"> <li>• PULSOUTP.                      • STATUSOUTP.</li> </ul> <i>Select with key ↑.</i> <i>Press key ↵ to transfer to subfunction "SELF CHECK".</i>
	→ SELF CHECK	<b>Carry out self check?</b> See Section 5.18. <ul style="list-style-type: none"> <li>• YES                      • NO                      (testing different parameters)</li> </ul> <i>Press key ↵ to transfer to subfunction "FIELD CURRENT".</i>
	→ FIELD CUR.	Determine field current <ul style="list-style-type: none"> <li>• INTERNAL</li> <li>• EXTERNAL      (only with power driver, see Sect. 8.6)</li> </ul> <i>Press ↵ key to return to Fct. 3.07 "HARDWARE".</i>

## 4.5 Error messages in measuring mode

The following list contains all errors which may occur during flow measurement. Errors are displayed when "YES" is selected in Fct. 1.04 DISPLAY, subfunction "DISP. MSG."

Error message	Description of error	Elimination of error
LINE INT.	Power failure <u>Note:</u> no counting during power failure	Cancel error in RESET/QUIT. menu Reset totalizer if necessary.
OVERFLOW I or OVERFL. I2	Current output overranged. (flow rate > measuring range)	Check instrument parameters and correct if necessary. After elimination of the cause, the error message is cancelled automatically. See Sections 6.4 and 6.7.
OVERFLOW P or OVERFL. P2	Pulse output P or Pulse output range P2 exceeded (flow rate > modulation range)	Check instrument parameters and correct if necessary. After elimination of the cause, the error message is cancelled automatically. See Sections 6.4 and 6.7.
I SHORT or I2 SHORT                      *	Current output I or I2 externally shorted or load < 15 Ω	Check mA loop and increase load using additional resistor if necessary.
I OPEN or I2 OPEN                      *	mA loop interrupted by current output I or I2 or load > 500 Ω	Check mA loop and reduce load to 500 Ω if necessary.
TOTALIZER	Overflow of internal totalizer	Delete error message in RESET/QUIT menu, see Sect. 4.6
ADC	Analog/digital converter range exceeded	Set Fct. 3.06, subfunction ADC GAIN to "10". See Sections 6.4 and 6.7. If error message does not disappear, consult factory.
ADC-PARAM.	Check sum error	Replace ADC printed circuit board
ADC-HARDW.	Hardware error A/D converter	Replace ADC printed circuit board
ADC GAIN	Hardware error A/D converter	Replace ADC printed circuit board
FC-HARDW.	Hardware error on field current PCB	Replace field current PCB
FATAL.ERROR	Fatal error, measurement interrupted	Replace electronic unit or consult factory.
EP PARAM.	Parameters of "Empty Pipe" are wrong	Error shut off automatically EPD function. Please check calibration values! Value Empty Pipe – Value Full pipe ≥ 10 Values must be in range of 0 – 150.

\* only for active operation

## 4.6 Resetting the totalizer and deleting error messages, RESET/QUIT menu

### Delete error messages in RESET/QUIT menu

Key	Display	Description
	-----	----- / ---
	Measuring mode	
↵	<b>Code 2</b>	--
	Key-in entry code 2 for RESET/QUIT menu: ↑ →	
↑ →		<b>ERROR QUIT.</b>
	Menu for error acknowledgement	
→		<b>QUIT. NO</b>
	<b>Do not</b> delete error messages, press ↵ twice to return to measuring mode.	
↑		<b>QUIT. YES</b>
	Delete error messages	
↵		<b>ERROR QUIT.</b>
	Error messages deleted.	
↵	-----	----- / ---
	Return to measuring mode	

### Reset totalizer in RESET/QUIT menu

Key	Display	Description
	-----	----- / ---
	Measuring mode	
	<b>Code 2</b>	--
	Key-in entry code 2 for RESET/QUIT menu: ↑ →	
↑ →		<b>ERROR QUIT.</b>
	Menu for error acknowledgement	
↑		<b>TOTAL.RESET</b>
	Menu for resetting totalizer	
→		<b>RESET NO</b>
	<b>Do not</b> reset totalizer, press ↵ twice to return to measuring mode	
↑		<b>RESET YES</b>
	Reset totalizer	
↵		<b>TOTAL.RESET</b>
	Totalizer is reset	
↵	-----	----- / ---
	Return to measuring mode	

## 4.7 Examples of signal converter settings

In the following example the cursor or flashing part of the display is shown in **bold** characters.

- **Change measuring range of current output and value for error messages** (Fct. 1.05):
- Change measuring range from 04-20 mA to **00-20 mA**
- Change value for error messages from 0 mA to **22 mA**

Key	Display	Description
→		If "YES" is selected in Fct. 3.04 ENTRY CODE, enter the 9-digit entry CODE 1: → → → ↑ ↑ ↵ ↵ ↵
	Fct. 1.00	<b>OPERATION</b>
→	Fct. 1.01	<b>FULL SCALE</b>
4x ↑	Fct. 1.05	<b>CURRENT I</b>
→		FUNCT. I
→ ↵		RANGE I
→	<b>04-20</b>	mA
2x ↑	<b>00-20</b>	mA
↵		I ERROR
→	<b>0</b>	mA
↑	<b>22</b>	mA
↵	Fct. 1.05	<b>CURRENT I</b>
↵	Fct. 1.00	<b>OPERATION</b>
↵		<b>STORE YES</b>
↵	-----	----- / ---
	Measuring mode with new current output data	

## 6 Special Applications, Functional Checks, Service and Order Numbers

### 6.1 Use in hazardous areas

#### 6.1.1 General

Signal converters of type IFC 110 F - EEx are type tested as associated electrical apparatus in compliance with European Directive 94/9/EG (ATEX 100a) in conformity with European Standards EN 50 014 / EN 50 020.

The EC type examination certificate has been issued by the Physikalisch-Technische Bundesanstalt (PTB) under: **PTB 02 ATEX 2163 X**



#### Important, please note!

- Observe the directions, regulations and electrical data specified in the EC type examination certificate, see Section 13.
- In addition to the regulations for power installations (VDE 0100), pay particular attention to the regulations specified in EN 60079-14 "Electrical installations in hazardous areas".
- Assembly, installation, commissioning and maintenance may only be carried out by "personnel trained in explosion protection"!

#### 6.1.2 Main safety features

Both generation of the intrinsically safe electrode circuit and also protection of the non-intrinsically safe field circuit by fusible links form integral parts of the IFC 110 F - EEx signal converter.

##### • Category / Zone

IFC 110 F - EEx signal converters are associated electrical apparatus required to be installed outside the hazardous area.

The **intrinsically safe electrode circuit** is designed in **Category 2** for use in Zone 1.

##### • Types of protection

The **electrode circuit** is designed in Intrinsic Safety **EEx ib IIC** type of protection.

The **non-intrinsically safe field circuit** must be installed inside the hazardous area using a type of protection conforming to European Standard (e.g. Increased Safety "e").

**Power supply** and **signal inputs / outputs** are non-intrinsically safe.

##### • Field current fuse protection

The field circuit is fuse-protected in the signal converter IFC 110F – EEx by two fusible links on the FSV circuit board (TR5, 160 mA F).

##### • Safety-relevant type code

The following code is used for type designation:

#### **IFC 110 F / ... - E Ex**

1 2 3 4 5 6

- 1 Electromagnetic signal converter
- 2 Type series
- 3 Field housing for "remote" measuring systems
- 4 Marking – no effect on explosion protection  
S Special version for -40 °C  
... others as required
- 5 Approval to European standard
- 6 Explosion-protected equipment

### 6.1.3 Installation and electrical connection

Type IFC 110 F - EEx signal converters are type tested as **associated electrical apparatus**. They are installed outside the hazardous area.

The PE/PA connection (housing) must have protective bonding with the potential of the hazardous area (PA).



#### Insulation ratings

The insulation of signal converters Type IFC 110 F - EEx is rated in conformity with VDE 0110-1, equivalent to IEC 664-1, and the following rated values have been taken into consideration:

- overvoltage category for the line circuit: III
- overvoltage category for the signal and measuring circuits: II
- insulation pollution degree: 2

#### Important, please note without fail!

- The buffer barrier for the intrinsically safe electrode circuit is an integral part of the IFC 110 F - EEx signal converter and is safety galvanically isolated.
- The cable entry for the interconnecting cable of the intrinsically safe electrode circuit is marked in light blue.
- The terminals of the intrinsically safe electrode circuit may only be connected to intrinsically safe circuits, even if the device is operated in the non-hazardous area.
- Electrical connection between front panel and potential to ground to be made by way of the fastening screws on the front panel. These must therefore always be properly tightened down (torque approx. 1.3 Nm).

#### Start-up

Check the following points before starting up:

- that the line voltage (power supply) agrees with the details given on the nameplate.
- that the nominal value of the fuse for field current protection agrees with the maximum permissible nominal value specified for the flow sensor.

Evidence shall be furnished of the intrinsic safety for the electrode circuit together with the safety-relevant data of the interconnecting cable and of the flow sensor.

#### Operation

Operator control of the signal converter is permitted during operation. For this purpose, remove the cover of the electronic compartment. Definitely avoid ingress of dirt and moisture when the housing cover is open.

#### Preventive maintenance

The signal converter does not require any maintenance when used for the intended purpose. Within the scope of checks required to be carried out in hazardous areas to maintain systems in proper working order, visual inspection of the housing, cable entries and interconnecting cables for signs of damage should be carried out at regular intervals.

#### Maintenance

Maintenance work of a safety-relevant nature within the meaning of explosion protection may only be carried out by the manufacturer, his authorized representative or under the supervision of authorized inspectors.



#### Please note !

Safety data see Sect. 10.1 !

## 10 Technical data

### 10.1 Signal converter

#### Mode of operation and system structure

Measurement principle	Faraday's law of induction
Modularity	Measuring system consisting of signal converter and flow sensor
Measured variable	Volumetric flowrate (electrode voltage from flow sensor)
Electrical conductivity of product	≥ 5 µS/cm ≥ 20 µS/cm for demineralized cold water

#### Versions

IFC 110 F / D (standard)	Display version, <b>with</b> local display / control elements (15 keys) same as display version, additionally with magnetic sensors (MP) to control the signal converter using bar magnet without opening the housing
IFC 110 F / D / MP (option)	
IFC 110 F / D / MP / _ EEx (option)	ATEX-EEx version for hazardous areas, PTB 02 ATEX 2163 X
Interfaces	<ul style="list-style-type: none"> <li>- HART®</li> <li>- RS 485 / PROFIBUS</li> </ul> } add-on module
Add-on equipment	- CONFIG software and adapter for operator control via MS-DOS-PC, connection to internal IMoCom interface (equipment bus)

#### Full-scale range

Flowrate for Q = 100%	6 Liter/h to 86 860 m³/h or 0.03 to 401 080 US Gal/min, corresponding to flow velocity v = 0.3 – 12 m/s or v = 1 to 40 ft/s
Units	m³/h, liter/s, US Gal/min or user-defined unit, e. g. liter/day or US Gal/day

#### Input / output circuits

Nominal voltages	≤ 25 V AC / ≤ 50 V DC (safety value Um = 253 V)
Active / passive/ mode	connection to protective extra-low voltage (PELV)

#### Current output

Function	<ul style="list-style-type: none"> <li>- all operating data configurable</li> <li>- galvanically isolated from all input and output circuits</li> </ul>	
Current:	fixed ranges	0 – 20 mA and 4 – 20 mA
	variable ranges	for Q = 0%    I <sub>0%</sub> = 0 – 16 mA for Q = 100%    I <sub>100%</sub> = 4 – 20 mA for Q > 100%    I > 20 – 22 mA (maximum)
Load	- active operation	min. 15 Ω
	- passive operation	22 V DC ≤ U ≤ 32 V DC: R <sub>L</sub> ≤ 800 Ω 15 V DC ≤ U ≤ 22 V DC: R <sub>L</sub> ≤ 500 Ω
Error identification	0 / 22 mA and variable	
Forward/reverse flow measurement	direction identified via status output	

#### Pulse outputs (passive)

Function	<b>P</b>	<b>A1</b> (can also be operated as status output)
Terminals	- for electronic totalizers - all operating data settable	- for electromechanical totalizers - all operating data configurable
Pulse rate	P / P 0 – 10 000 pulses per s [= Hz], min, h, m³, liter, etc., any scaling	A1 / A ⊥ 0 – 50 pulses per s [= Hz], min, h, m³, liter, etc., any scaling
Electrical data	galvanically isolated U ≤ 32 V DC / ≤ 24 V AC I ≤ 30 mA, any polarity	galvanically isolated, but not from <b>A2</b> U ≤ 32 V DC / ≤ 24 V AC I ≤ 100 mA, any polarity <b>or</b> U ≤ 32 V DC, I ≤ 200 mA note polarity
Pulse width	automatic: pulse duty cycle 1:1, max. 10 000 pulses/s = 10 kHz	
	variable: 10 ms – 1 s, P <sub>100%</sub> [pulses/s] = f <sub>max</sub> [Hz] = $\frac{1}{2 \times \text{pulse width}}$	
	digital pulse division, interpulse period non-uniform, therefore if frequency and cycle meters connected allow for minimum counting interval:	
	gate time, totalizer ≥ $\frac{1000}{P_{100\%} [\text{Hz}]}$	
Forward/reverse flow measurement	direction identified via status output	

<b>Status outputs</b> (passive) Function, set for	<b>D1 / D2 / A2</b> trip point flow direction automatic range change error identification overdriving empty pipeline	<b>A1</b> (can also be operated as pulse output) trip point flow direction automatic range change error identification overdriving empty pipeline
Terminals	D1 / D2 / D ⊥ / A2 / A ⊥ <b>Please note:</b> D ⊥ common reference potential for D1 and D2 A ⊥ common reference potential for A1 and A2	A1 / A ⊥
Electrical data	galvanically isolated U ≤ 32 V DC / ≤ 24 V AC I ≤ 100 mA, any polarity	galvanically isolated, but not from A2 U ≤ 32 V DC / ≤ 24 V AC I ≤ 100 mA, any polarity <b>or</b> U ≤ 32 V DC, I ≤ 200 mA, note polarity
<b>Control inputs C1 and C2</b> (passive) Function, set for	automatic range change, totalizer reset, error reset, start self-test, set outputs to min. values or hold last measured values of outputs	
Terminals	C1 / C ⊥ and C2 / C ⊥, galvanically isolated <b>Please note:</b> C ⊥ common reference potential for C1 and C2 U = 8 – 32 V DC, I ≤ 10 mA, any polarity	
<b>Internal power supply</b> Terminals	for passive outputs and inputs and external receiver instruments E + and E –, please note polarity, galvanically isolated	
Electrical data	U = 24 V DC / R <sub>i</sub> = approx. 15 Ohm / I ≤ 100 mA	
<b>Time constant</b>	0.2 – 99.9 s, adjustable in increments of 0.1 second	
<b>Low-flow cutoff</b>	cutoff "on" value: 1 – 19 % cutoff "off" value: 2 – 20 % } of Q <sub>100%</sub> , adjustable in 1% increments	
<b>Local display and operation</b> Display function	3-line back-lit LCD actual flowrate, forward, reverse, sum totalizers (7 digits) or 25-character bar graph with percent display and status messages	
Units:	actual flowrate	m <sup>3</sup> /h, liter/s., US gallons/min or user-defined unit, e. g. hecto liter/h
	totalizer	m <sup>3</sup> , liter, or US gallons or user-defined unit (adjustable counting time till overflow)
Language of plain texts	English, German, French, Swedish, others on request	
Display:	1st line	8-character, 7-segment, numerical and sign display, and symbols for key acknowledgement
	2nd line	10-character, 14-segment, text display
	3rd line	6 markers to identify display in measuring mode
Operation elements	15 keys or as option with 3 additionally magnetic sensors for operation without opening the housing	
<b>Electrode circuit</b> Type of protection	intrinsic safety [EEx ib IIC]	
Max. values (cumulative)	U <sub>0</sub> = 18 V / I <sub>0</sub> = 40 mA / P <sub>0</sub> = 80 mW	
Kinked characteristic	capacitance C <sub>0</sub> ≤ 225 nF / inductance L <sub>0</sub> ≤ 5 mH	
<b>Field power supply</b> Type	pulsed bipolar DC field for all KROHNE primary heads, galvanically isolated from all input and output circuits	
Terminals	2 x 7 and 8	
Current / voltage	± 0.125 A (± 5%) / U <sub>N</sub> ≤ 40 V DC (frequency controlled)	
Clock frequency	1/36 to 1/2 of power frequency, configurable to the calibration data of the primary head	
Internal fuse protection	I <sub>N</sub> ≤ 160 mA	
<b>Power supply</b>	<b>AC version standard</b>	<b>AC / DC version</b> (switch-selectable) option, in preparation
Voltage range (without change over)	100 – 230 V AC	24 V AC ; 24 V DC
Tolerance band	85 – 255 V AC	20.4 – 26.4 V AC ; 18 – 31.2 V DC
Safety value	U <sub>m</sub> = 253 V	U <sub>m</sub> = 253 V
Frequency	48 – 63 Hz	48 – 63 Hz ; –
Power consumption (incl. primary head)	18 VA, typical (max. 25 VA)	18 VA, typical (max. 25 VA) ; 18 W, typical (max. 18 W)
When connected to a functional extra-low voltage, 24 V AC / DC, protective separation (PELV) must be ensured (VDE 0100 / VDE 0106 and IEC 364 / IEC 536 or equivalent national standards).		
<b>Approvals and housing</b> Material of field housing	die-cast aluminium with polyurethane finish	
Ambient temperature	• operation	standard -25 to +60 °C / -13 to +140 °F EEx -20 to +55 °C / - 4 to +131 °F EEx, special "S" -40 to +55 °C / -40 to +131 °F
	• storage	all versions -40 to +60 °C / -40 to +140 °F
Protection category (IEC 529 / EN 60 529)	IP 65, equivalent to NEMA 4 / 4X to EN 61326-1 (1977) and A1 (1998) directives and NAMUR Standard NE 21	
EU EMC Directives	II (2) G [EEx ib] IIC	
Certificates and approvals	PTB 02 ATEX 2136 X	

## 10.2 Error limits

### Display, digital values, pulse output

**F** maximum error in % of measured value (MV), **not** typical values

**v** Flow velocity in m/s and ft/s

#### Reference conditions similar to EN 29 104

Product	water at 10 – 30°C / 50 – 86°F
Electrical conductivity	> 300 µS/cm
Power supply (rated voltage)	U <sub>N</sub> (± 2%)
Ambient temperature	20 – 22°C / 68-71.6 °F
Warm-up time	60 min
Max. calibration equipment error	10 × smaller than F
Inlet / outlet runs	10 × DN / 2 × DN (DN = meter size)
Flow sensor	properly grounded and centered

Calibrated on EN 17025 accredit to calibration equipment in direct volumetric comparison.

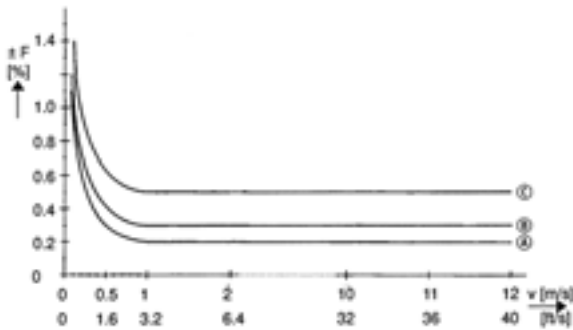

\* VARIFLUX 6000 F (DN 2.5 – 4 and 1/10" – 1/6") additional error ± 0,3% of MV

**MV** Measured Value

**z** = 1 mm/s = 0.04 inch/s

Flow sensor	Meter size		Standard details		Curve	Option (extra charge)		Curve
	DN mm	inch	v ≥ 1.0 m/s v ≥ 3.3 ft/s	v < 1.0 m/s v < 3.3 ft/s		v ≥ 1.0 m/s v ≥ 3.3 ft/s	v < 1.0 m/s v < 3.3 ft/s	
VARIFLUX 6000 F	2.5- 6	1/10 - 1/4	± 0.5% of MV	± 0.4% of MV + z	C	–	–	–
	10 - 80	3/8 - 3	± 0.3% of MV	± 0.2% of MV + z	B	–	–	–
PROFIFLUX 5000 F	2.5- 6	1/10 - 1/4	± 0.5% of MV	± 0.4% of MV + z	C	–	–	–
	10 - 100	3/8 - 4	± 0.3% of MV	± 0.2% of MV + z	B	± 0.2% of MV	± 0.1% of MV + z	A
ALTOFLUX 4000 F	10 - 25	3/8 - 1	± 0.3% of MV	± 0.2% of MV + z	B	–	–	–
	32 -1600	1 1/4 -64	± 0.3% of MV	± 0.2% of MV + z	B	± 0.2% of MV	± 0.1% of MV + z	A
ALTOFLUX 2000 F	150 - 250	6 -10	± 0.3% of MV	± 0.2% of MV + z	B	± 0.2% of MV	± 0.1% of MV + z	A
ECOFLEX 1000 F	10 - 150	3/8 - 6	± 0.5% of MV	± 0.4% of MV + z	B	–	–	–
M 900	10 - 25	3/8 - 1	± 0.3% of MV	± 0.2% of MV + z	B	–	–	–
	32 - 300	1 1/4 -12	± 0.3% of MV	± 0.2% of MV + z	B	± 0.2% of MV	± 0.1% of MV + z	A

**Current output** same error limits as above, additionally ± 10 µA

**Reproducibility and repeatability** 0,1% of MV, minimum 1 mm/s / 0.04 inch/s at constant flow

**External influences** typical values maximum values

**Ambient temperature**

Pulse output	0,003% of MV (1)	0,01 % of MV (1)	} per 1 K / 1.8° F temperature variation
Current output	0,01 % of MV (1)	0,025% of MV (1)	

**Power supply** < 0,02 % of MV 0,05 % of MV at 10% variation

**Load** < 0,01 % of MV 0,02 % of MV, at max. load, see Sect. 10.1

(1) All KROHNE signal converters undergo burn-in tests, duration minimum 20 hours at varying ambient temperatures – 20 to + 60°C/– 4 to + 140°F. The tests are controlled by computers.



### 10.3 Dimensions and weights IFC 110 F / IFC 110 F-EEx and ZD / ZD-EEx

Dimensions in mm and inch

#### IFC 110 F Signal converters

Weight approx. 4.1 kg / 9.0 lbs

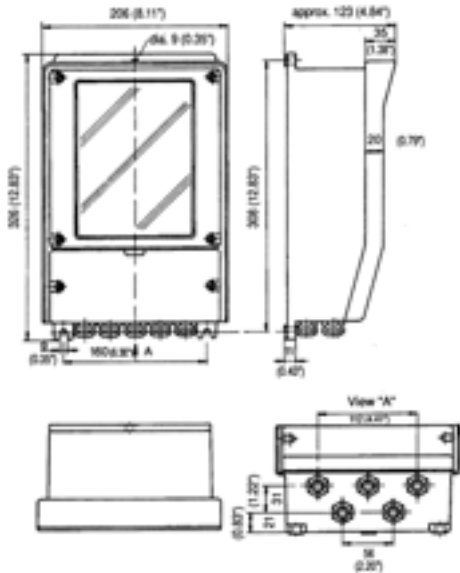

#### ZD Intermediate connection box

Weight approx. 0.5 kg / 1.1 lbs

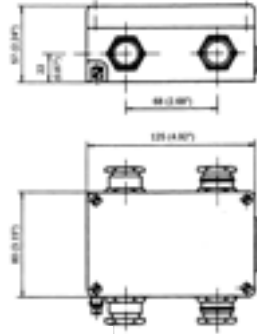

### 10.4 Flow table

v = flow velocity in m/s and ft/s

Meter size		Full-scale range $Q_{100\%}$ in $m^3/h$		
DN		$v = 0.3$ m/s	$v = 1$ m/s	$v = 12$ m/s
mm	inch	(minimum)		(maximum)
2.5	1/10	0.0053	0.0177	0.2121
4	1/8	0.0136	0.4520	0.5429
6	1/4	0.0306	0.1018	1.222
10	3/8	0.0849	0.2827	3.392
15	1/2	0.1909	0.6362	7.634
20	3/4	0.3393	1.131	13.57
25	1	0.5302	1.767	21.20
32	-	0.8686	2.895	34.74
40	1 1/2	1.358	4.524	54.28
50	2	2.121	7.069	84.82
65	-	3.584	11.95	143.3
80	3	5.429	18.10	217.1
100	4	8.483	28.27	339.2
125	-	13.26	44.18	530.1
150	6	19.09	63.62	763.4
200	8	33.93	113.1	1357
250	10	53.02	176.7	2120
300	12	76.35	254.5	3053
400	16	135.8	452.4	5428
500	20	212.1	706.9	8482
600	24	305.4	1018	12215
700	28	415.6	1385	16625
800	32	542.9	1810	21714
900	36	662.8	2290	26510
1000	40	848.2	2827	33929
1200	48	1221	4072	48858
1400	56	1663	5542	66501
1600	64	2171	7238	86859

Meter size		$Q_{100\%}$ in US Gal/min	
DN		$v = 1$ ft/s	$v = 40$ ft/s
inch	mm	(minimum)	(maximum)
1/10	2.5	0.0245	0.979
1/8	4	0.0383	1.530
1/4	6	0.1530	6.120
3/8	10	0.3735	14.93
1/2	15	0.8405	33.61
3/4	20	1.494	59.75
1	25	2.334	93.34
-	32	3.824	153.0
1 1/2	40	5.979	239.0
2	50	9.339	373.5
-	65	15.78	630.9
3	80	23.90	955.6
4	100	37.35	1493
-	125	37.35	2334
6	150	84.05	3361
8	200	149.43	5975
10	250	233.4	9334
12	300	336.2	13442
16	400	597.9	23899
20	500	933.9	37345
24	600	1345	53781
28	700	1919	76760
32	800	2507	100272
36	900	3173	126904
40	1000	3917	156672
48	1200	5640	225608
56	1400	7677	307080
64	1600	10027	401080

---

## 13 Approvals

---

### 13.1 EC-type examination certificate

English translation

### 13.2 EC-type examination certificate

German original

For the approvals see Handbook / Service Manual.

**If you need to return flowmeters for testing or repair to KROHNE**

Your electromagnetic flowmeter

- has been carefully manufactured and tested by a company with ISO 9001 certification
- and volumetrically calibrated in one of the world's most accurate test rigs.

If installed and operated in accordance with these operating instructions, your flowmeter will rarely present any problems.

Should you nevertheless need to return a flowmeter for checkout or repair, please pay strict attention to the following points:

Due to statutory regulations concerning protection of the environment and the health and safety of our personnel, Krohne may only handle, test and repair returned flowmeters that have been in contact with liquids if it is possible to do so without risk to personnel and environment. This means that Krohne can only service your flowmeter if it is

accompanied by a certificate in line with the following model confirming that the flowmeter is safe to handle.

If the flowmeter has been operated with toxic, caustic, flammable or water-endangering liquids, you are kindly requested

- to check and ensure, if necessary by rinsing or neutralizing, that all cavities in the flowmeter are free from such dangerous substances.  
(Directions on how you can find out whether the flow sensor has to be opened and then flushed out or neutralized are obtainable from Krohne on request.)
- to enclose a certificate with the flowmeter confirming that the flowmeter is safe to handle and stating the liquid used.

KROHNE regret that they cannot service your flowmeter unless accompanied by such a certificate.

**SPECIMEN certificate**

Company: ..... Address: .....

Department: ..... Name: .....

Tel. No.: .....

The enclosed electromagnetic flowmeter

Type: ..... KROHNE Order No. or Series No .....

has been operated with the following liquid: .....

Because this liquid is

water-endangering \* / toxic \* / caustic \* / flammable \*

we have

- checked that all cavities in the flowmeter are free from such substances \*
- flushed out and neutralized all cavities in the flowmeter \*

(\* delete if not applicable)

We confirm that there is no risk to man or environment through any residual liquid contained in this flowmeter.

Date: ..... Signature: .....

Company stamp: