

Installation and Operating Instructions

LEM 300

Double level control unit for LS 7000 series



Electromagnetic flowmeters

Variable area flowmeters

Mass flowmeters

Ultrasonic flowmeters

Vortex flowmeters

Flow controllers

Level measuring instruments

Pressure and temperature

Heat metering

Communications technology

Switches, counters, displays and recorders

Engineering systems & solutions

Contents

Description.....	3
Product liability and warranty	3
1 Safety Instructions.....	4
2 Description	4
3 Technical data	5
4 Application Example.....	6
4.1 Example 1	6
4.2 Example 2	7
4.3 Example 3	8
4.4 Example 4	9
4.5 Example 5	10
If you need to return a device for testing or repair to KROHNE.....	11

Description

The Double Level Control Unit has two independent, galvanically separated electrical circuits. Each circuit controls a relay with Normally Open contacts. The status of each relay changes as a function of the two resistance inputs.

The two inputs act with a hysteresis. The sensibility of the relay circuit can be adjusted from the front of the module. LED's indicates an activated relay.

The module can be used as an evaluation module for LS 7000 series sensors. Please refer to the application example(s).

Product liability and warranty

Responsibility as to suitability and intended use of this instrument rests solely with the operator. Improper installation and operation of the instrument / system may lead to loss of warranty.

In addition, all claims are subject to the "General terms and conditions of sale" under which this instrument was purchased.

If a meter or instrument needs to be returned to KROHNE, please note the information given on the last-but-one page of these Instructions.

KROHNE regrets that it cannot repair or check your instruments unless they are accompanied by a fully completed Service and Repair sheet.

1 Safety Instructions

This instrument is built and tested according to the specifications and packed in technically safe condition. In order to maintain this condition and to ensure safe operation, the user shall follow the hints and warnings given in this instruction.



WARNING

During the installation the valid national rules have to be observed. Ignoring the warnings may lead to severe personal injury or substantial damage to property.

The product shall be operated by trained staff. Correct and safe operation of this equipment is dependent on proper transport, storage, installation and operation.

All electrical wiring shall conform to local standards. In order to prevent stray electrical radiation, we recommend twisted and shielded input cables, as also to keep mains supply cables separated from the input cables. The connection shall be made according to the connecting diagrams.

2 Description

The Double Level Control Unit has two independent, galvanically separated electrical circuits. Each circuit controls a relay with Normally Open contacts. The status of each relay changes as a function of the two resistance inputs.

The two inputs act with a hysteresis. The sensibility of the relay circuit can be adjusted from the front of the module. LED's indicates an activated relay.

The module can be used as an evaluation module for LS 7000 series sensors. Please refer to the application example(s).

3 Technical data

Input

Range	7...100 KOhm (adjustable)
Probe voltage	24 V AC
Probe current	4 mA

Environmental conditions

Operating temperature	-20...+50°C
Storage temperature	-50...+85°C
Humidity	<85% RH, non-condensing

EMC data

Generic standards	EN 61000-6-3, EN 61000-6-2
LVD standards	EN 61010-1, EN60204-1

Mechanical data

Dimensions	91.5 x 98 x 35 mm
DIN-rail mounting	DIN 46277
Protection class	Housing: IP 20
Weight	0.325 kg

Power supply

Supply range	230 V AC (+10 /-15%)
Frequency	50/60 Hz
Power consumption	15 mA

Output Relay

Resistive load	AC: 250 V / 10 A DC: 200 V / 0.4 A DC: 24 V / 10 A
Inductive load	AC: 250 V / 5 A DC: 24 V / 5 A
Mechanical life cycle	>30 x 10 ⁶ operations
Operation voltage	250...440 V AC

Disposal of product and packing

According to national laws or by returning to KROHNE

4 Application Example

4.1 Example 1

A tank is being filled with waste water. Pump 1 is supplying a filter unit. Pump 2 is securing the tank from overflowing.

Tank: Metal
Ground: Via the LS 72XX process connection
Instrument: LS 7240, 4 coated rods.

- < Y1 level: Stop Pump 1
- > Y2 level: Start Pump 1
- < Y3 level: Stop Pump 2
- > Y4 level: Start Pump 2

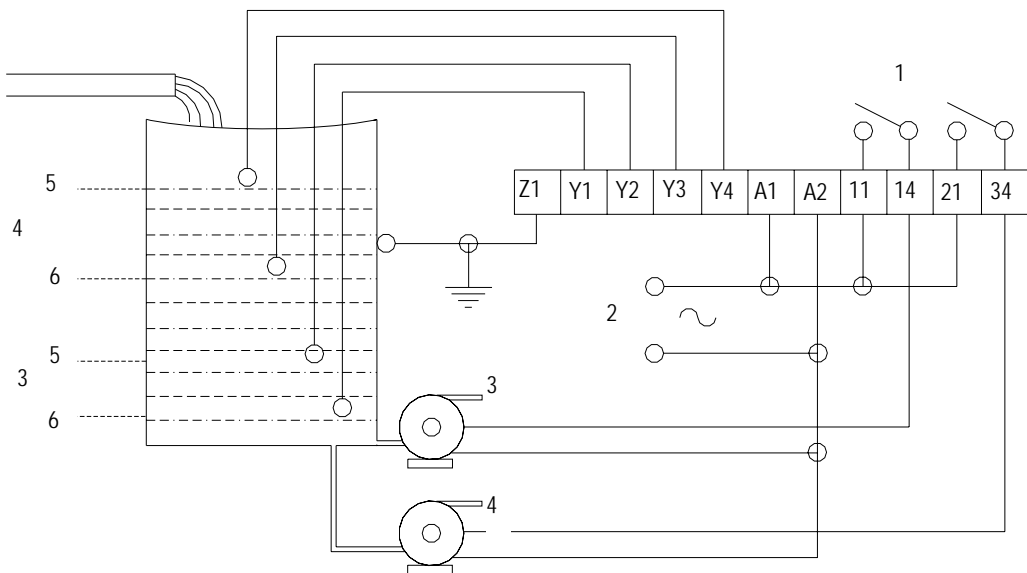
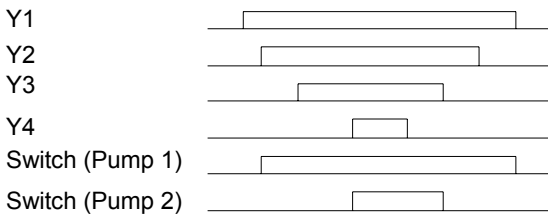

- 1 Switches »Normally open«
- 2 230 V AC
- 3 Pump 1
- 4 Pump 2
- 5 Max.
- 6 Min.

4.2 Example 2

Pump1 is filling a tank to a certain level. The alarm is securing the tank from overflowing.

Tank: Non-Metal

Ground: Via one uncoated rod

Instrument: LS 7240, 3 coated rods, 1 uncoated.

<Y1 level: Start Pump1

>Y2 level: Stop Pump1

Y3 + Y4 level: Alarm

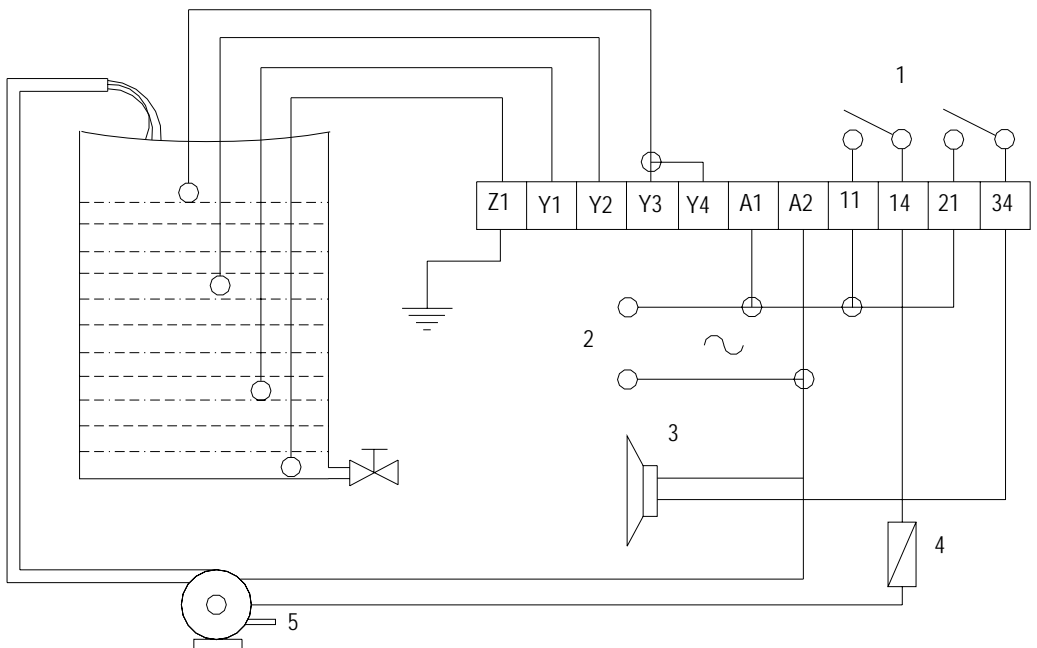

- 1 Switches »Normally open«
- 2 230 V AC
- 3 Alarm
- 4 Reversing relay
- 5 Pump 1

4.3 Example 3

A tank is being filled with waste water. Pump 1 is supplying a filter unit. Pump 2 is securing the tank from overflowing.

Tank: Non-metal

Ground: Via one uncoated rod

Instrument: LS 7240, 3 coated rods, 1 uncoated.

< Y1 + Y3 level: Stop Pump 1 + Pump 2

> Y2 level: Start Pump 1

> Y4 level: Start Pump 2

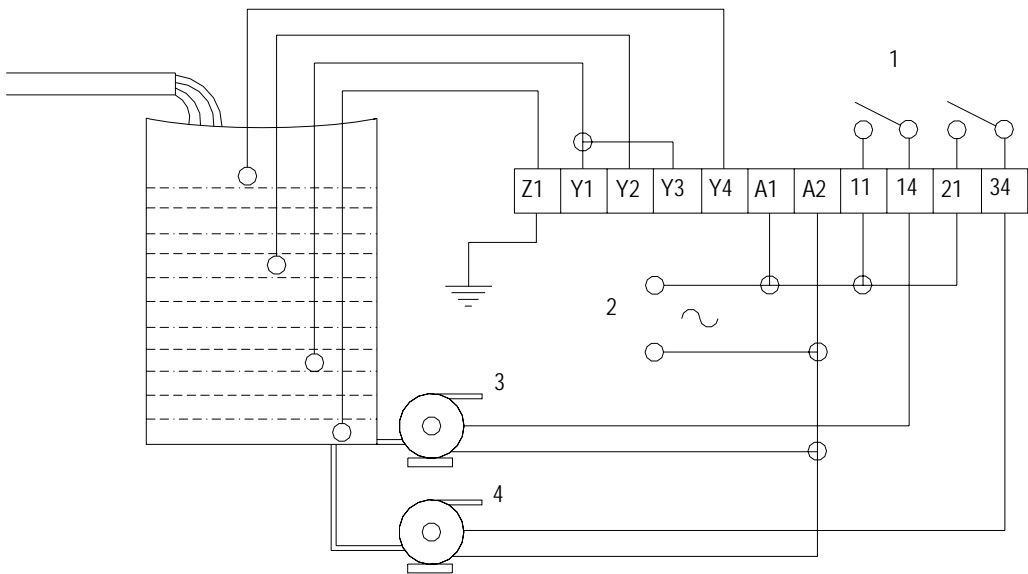

- 1 Switches »Normally open«
- 2 230 V AC
- 3 Pump 1
- 4 Pump 2

4.4 Example 4

Tank 1 is being filled with water and emptied via a water tap. Security valve1 is securing the tank from overflowing.

Tank 1: Metal

Ground: Via the LS 72XX process connection.

Instrument: LS 7240, 2 coated rods.

< Y1 level: Close valve1

> Y2 level: Open valve1

Tank 2 is filled via pump 2 and emptied via a water tap.

Tank 2: Metal

Ground: Via the LS 72XX process connection.

Instrument: LS 7240, 2 coated rods.

< Y3 level: Start Pump 2

> Y4 level: Stop Pump 2

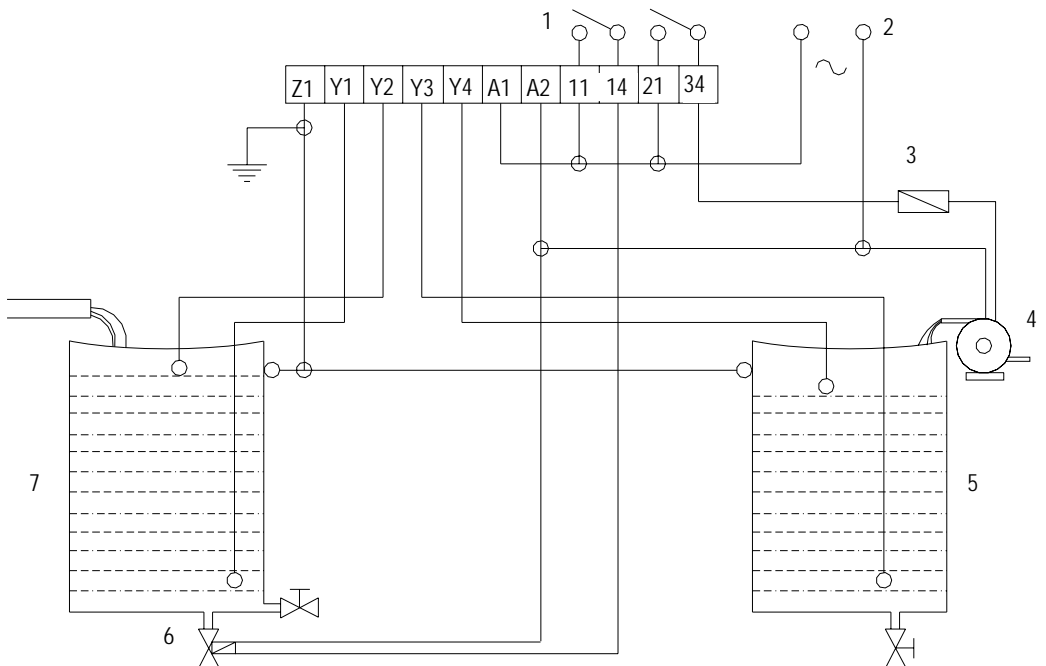

- 1 Switches »Normally open«
- 2 230 V AC
- 3 Reversing relay 2
- 4 Pump 2
- 5 Tank 2
- 6 Valve 1
- 7 Tank 1

4.5 Example 5

Tank 1 and Tank 2 are being filled with water via Pump 1 and Pump 2.

Tank 1: Metal

Ground 1: Via the LS 72XX process connection

Instrument 1: LS 7200 - stub version.

Tank 2: Non-metal

Ground 2: Via one uncoated rod

Instrument 2: LS 7XXX- one coated rod - one uncoated rod.

Power on: Start Pump 1 and Pump 2

< Y1 + Y2 level: Start Pump 1

< Y3 + Y4 level: Start Pump 2

> Y1 + Y2 level: Stop Pump 1

> Y3 + Y4 level: Stop Pump 2

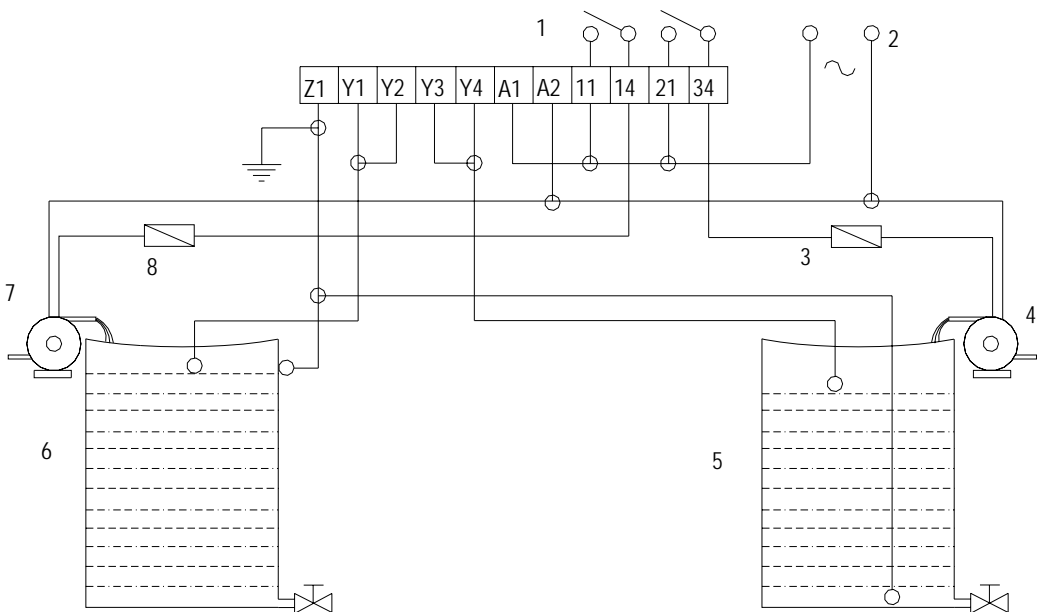

- 1 Switches »Normally open«
- 2 230 V AC
- 3 Reversing relay 2
- 4 Pump 2
- 5 Tank 2
- 6 Tank 1
- 7 Pump 1
- 8 Reversing relay 1

If you need to return a device for testing or repair to KROHNE

Your instrument has been carefully manufactured and tested. If installed and operated in accordance with these operating instructions, your instrument will rarely present any problems. Should you nevertheless need to return an instrument for checkout or repair, please pay strict attention to the following points:

Due to statutory regulations concerning protection of the environment and safeguarding the health and safety of our personnel, KROHNE may only handle, test and repair returned instruments that have been in contact with liquids if it is possible to do so without risk to personnel and environment.

This means that KROHNE can only service your instrument if it is accompanied by a certificate in line with the following model confirming that the instrument is safe to handle.

If the instrument has been operated with toxic, caustic, flammable or water-endangering liquids, you are kindly requested

- to check and ensure, if necessary by rinsing or neutralizing, that all cavities in the instrument are free from such dangerous substances.
(Directions on how you can find out whether the primary head has to be opened and then flushed out or neutralized are obtainable from KROHNE on request.)
- to enclose a certificate with the instrument confirming that the instrument is safe to handle and stating the liquid used.

KROHNE regret that they cannot service your instrument unless it is accompanied by such a certificate.

SPECIMEN certificate

Company: Address:

Department: Name:

Tel. No.:

The enclosed instrument

Type:

KROHNE Order No. or Series No

has been operated with the following liquid:

Because this liquid is
water-endangering * / toxic * / caustic * / flammable *
we have

- checked that all cavities in the instrument are free from such substances *
- flushed out and neutralized all cavities in the flowmeter *

(* delete if not applicable)

We confirm that there is **no** risk to man or environment through any residual liquid contained in the instrument.

Date: Signature:

Company stamp: