



LS 6500 Handbook

Switch for level detection and dry-run protection

All rights reserved. It is prohibited to reproduce this documentation, or any part thereof, without the prior written authorisation of KROHNE Messtechnik GmbH.

Subject to change without notice.

Copyright 2013 by
KROHNE Messtechnik GmbH - Ludwig-Krohne-Str. 5 - 47058 Duisburg (Germany)

1	Safety instructions	5
1.1	Intended use	5
1.2	Certifications	5
1.3	ATEX approval	5
1.4	Safety instructions from the manufacturer	6
1.4.1	Copyright and data protection	6
1.4.2	Disclaimer	6
1.4.3	Product liability and warranty	7
1.4.4	Information concerning the documentation	7
1.4.5	Warnings and symbols used	8
1.5	Safety instructions for the operator	8
2	Device description	9
2.1	Scope of delivery	9
2.2	System description	9
2.3	Nameplate	10
3	Installation	11
3.1	General notes on installation	11
3.2	Installation requirements	11
3.3	Process connection	11
3.4	Mounting of 3A marked products	12
3.5	Installation of sliding connection	13
4	Electrical connections	15
4.1	Safety instructions	15
4.2	Description of electrical connection	15
4.3	Electrical connection diagrams	16
4.4	Electrical connection data for use in hazardous areas	17
4.5	Configuration tool	18
4.6	Teach-In function	20
5	Operation	22
5.1	Start-up	22
5.2	Fault diagnosis and corrective action	22

6 Service	23
<hr/>	
6.1 Availability of services	23
6.2 Spare parts and accessories.....	23
6.3 Returning the device to the manufacturer.....	24
6.3.1 General information.....	24
6.3.2 Form (for copying) to accompany a returned device.....	25
6.4 Disposal	25
7 Technical data	26
<hr/>	
7.1 Measuring principle.....	26
7.2 Technical data.....	27
7.3 Dimensions and weights	29
8 Notes	30
<hr/>	

1.1 Intended use

The LS 6500 is a hygienic level switch for level detection and dry-run protection for liquids and solids. The device measures liquids such as water and beer and well as viscous and sticky products such as honey or toothpaste. Even dry medias can be measured such as sugar or flour.

The measurement is precise and not affected by the mounting position.

Coating of the sensor or condensate are not detected.



DANGER!

The LS 6500 can be used in hazardous areas. For detailed information refer to ATEX approval on page 5 and refer to Electrical connection data for use in hazardous areas on page 17.

1.2 Certifications

CE marking



The device fulfils the statutory requirements of the following EC directives:

- EMC specification acc. to EN 61326
- Vibration specification acc. to IEC 68-2-6, GL test 2

The manufacturer certifies successful testing of the product by applying the CE marking.

1.3 ATEX approval

The LS 6500 is approved for the use in hazardous areas in accordance with the current EC directives with the following classifications:

- ATEX II 1D Ex tD A20 IP67 100°C (ITS09ATEX16872X)
- ATEX II 3G Ex nA II T 5 (pending)
- ATEX II 1G Ex ia IIC T5 (pending)



INFORMATION!

For further information refer to Electrical connection data for use in hazardous areas on page 17.

1.4 Safety instructions from the manufacturer

1.4.1 Copyright and data protection

The contents of this document have been created with great care. Nevertheless, we provide no guarantee that the contents are correct, complete or up-to-date.

The contents and works in this document are subject to copyright. Contributions from third parties are identified as such. Reproduction, processing, dissemination and any type of use beyond what is permitted under copyright requires written authorisation from the respective author and/or the manufacturer.

The manufacturer tries always to observe the copyrights of others, and to draw on works created in-house or works in the public domain.

The collection of personal data (such as names, street addresses or e-mail addresses) in the manufacturer's documents is always on a voluntary basis whenever possible. Whenever feasible, it is always possible to make use of the offerings and services without providing any personal data.

We draw your attention to the fact that data transmission over the Internet (e.g. when communicating by e-mail) may involve gaps in security. It is not possible to protect such data completely against access by third parties.

We hereby expressly prohibit the use of the contact data published as part of our duty to publish an imprint for the purpose of sending us any advertising or informational materials that we have not expressly requested.

1.4.2 Disclaimer

The manufacturer will not be liable for any damage of any kind by using its product, including, but not limited to direct, indirect or incidental and consequential damages.

This disclaimer does not apply in case the manufacturer has acted on purpose or with gross negligence. In the event any applicable law does not allow such limitations on implied warranties or the exclusion of limitation of certain damages, you may, if such law applies to you, not be subject to some or all of the above disclaimer, exclusions or limitations.

Any product purchased from the manufacturer is warranted in accordance with the relevant product documentation and our Terms and Conditions of Sale.

The manufacturer reserves the right to alter the content of its documents, including this disclaimer in any way, at any time, for any reason, without prior notification, and will not be liable in any way for possible consequences of such changes.

1.4.3 Product liability and warranty

The operator shall bear responsibility for the suitability of the device for the specific purpose. The manufacturer accepts no liability for the consequences of misuse by the operator. Improper installation and operation of the devices (systems) will cause the warranty to be void. The respective "Standard Terms and Conditions" which form the basis for the sales contract shall also apply.

1.4.4 Information concerning the documentation

To prevent any injury to the user or damage to the device it is essential that you read the information in this document and observe applicable national standards, safety requirements and accident prevention regulations.

If this document is not in your native language and if you have any problems understanding the text, we advise you to contact your local office for assistance. The manufacturer can not accept responsibility for any damage or injury caused by misunderstanding of the information in this document.

This document is provided to help you establish operating conditions, which will permit safe and efficient use of this device. Special considerations and precautions are also described in the document, which appear in the form of underneath icons.

1.4.5 Warnings and symbols used

Safety warnings are indicated by the following symbols.



DANGER!

This information refers to the immediate danger when working with electricity.



DANGER!

This warning refers to the immediate danger of burns caused by heat or hot surfaces.



DANGER!

This warning refers to the immediate danger when using this device in a hazardous atmosphere.



DANGER!

These warnings must be observed without fail. Even partial disregard of this warning can lead to serious health problems and even death. There is also the risk of seriously damaging the device or parts of the operator's plant.



WARNING!

Disregarding this safety warning, even if only in part, poses the risk of serious health problems. There is also the risk of damaging the device or parts of the operator's plant.



CAUTION!

Disregarding these instructions can result in damage to the device or to parts of the operator's plant.



INFORMATION!

These instructions contain important information for the handling of the device.



LEGAL NOTICE!

This note contains information on statutory directives and standards.



• **HANDLING**

This symbol designates all instructions for actions to be carried out by the operator in the specified sequence.

➔ **RESULT**

This symbol refers to all important consequences of the previous actions.

1.5 Safety instructions for the operator



WARNING!

*In general, devices from the manufacturer may only be installed, commissioned, operated and maintained by properly trained and authorized personnel.
This document is provided to help you establish operating conditions, which will permit safe and efficient use of this device.*

2.1 Scope of delivery

**INFORMATION!**

Inspect the cartons carefully for damages or signs of rough handling. Report damage to the carrier and to the local office of the manufacturer.

**INFORMATION!**

Do a check of the packing list to make sure that you have all the elements given in the order.

**INFORMATION!**

Look at the device nameplate to ensure that the device is delivered according to your order. Check for the correct supply voltage printed on the nameplate.

The following items are supplied with the device:

- Measuring device
- Hygienic adapter
- Product documentation

2.2 System description

Inputting physical quantities into an SPC or PLC or other computer and control systems requires accurate and reliably working sensors. The sensor is a detecting element that converts physical quantities, such as temperature, level, pressure, conductivity, turbidity and flow, into an electrical signal. Locally further processed, usually by an integrated microcontroller, the measuring signal can be transmitted by analogue (e.g. 4...20 mA loop). The LS 6500 is designed to detect the level of liquids or for pump protecting purposes.

2.3 Nameplate



INFORMATION!

Look at the device nameplate to ensure that the device is delivered according to your order. Check for the correct supply voltage printed on the nameplate.

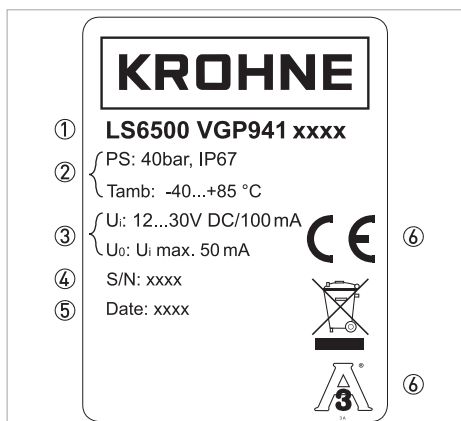

Figure 2-1: Example of non-Ex nameplate

- ① Device type
- ② Operating conditions (process pressure, process temperature and ambient temperature)
- ③ Electrical data
- ④ Serial number
- ⑤ Date of manufacture
- ⑥ Approvals and certifications



Figure 2-2: Example of Ex nameplate

- ① Ex approval symbol
- ② Ex relevant information

3.1 General notes on installation

**INFORMATION!**

Inspect the cartons carefully for damages or signs of rough handling. Report damage to the carrier and to the local office of the manufacturer.

**INFORMATION!**

Do a check of the packing list to make sure that you have all the elements given in the order.

**INFORMATION!**

Look at the device nameplate to ensure that the device is delivered according to your order. Check for the correct supply voltage printed on the nameplate.

3.2 Installation requirements

- Use only the recommended sleeves or adapters. If other systems are used, no guarantee can be given for proper functionality or leak-tightness.
- The connection thread must have direct electrical contact with the threaded sleeve and the metal tank or pipe.
- Do not use Teflon or paper gaskets between switch and hygienic adapter. The PEEK sensor together with the Stainless Steel adapter will perform a hygienic tightening. Assumed that the requirements have been followed.
- The tightening torque for the sleeve should be 20...25 Nm (for sliding connection 25...30 Nm).
- If the tank or pipe is electrically non-conductive (e.g. plastic), the metal face of a screw-in sleeve with a diameter of at least 28 mm / 1.1" will suffice as reference ground.

3.3 Process connection

The hygienic ½" process sleeve is easy to weld into tanks or pipes. The marking points to the centre of the future position of the cable gland or M12 plug connector. This form of assembly allows installation in conformity with standards of hygiene (to EHEDG, FDA).

Various hygienic adapter sleeves (refer to chapter "Accessories") are available for fitting to other process connections. For more information refer to data sheet "Accessories".
The sensor can be installed in any desired position.

3.4 Mounting of 3A marked products

The 3A mark is valid only when the product is mounted in a 3A marked counterpart and installed acc. to the installation manual. Use also a 3A marked O-ring or gasket if relevant.

The 3A marked products conforms to the 3A sanitary standards criteria. Materials and surfaces fulfil the FDA demands and are certified by EHEDG.

EPDM O-rings supplied with 3A marked products are conform to sanitary standards class II (8% milk fat).

- ① Use only 3A approved counterparts.
- ② The inspection hole should be visible and drained. Face it downwards that leaking can be observed.
- ③ Mount the device in a self-drained position.
- ④ Level the inner surface of the pipe with the counterpart.
- ⑤ Weld from the inside of the tank, if possible. Welds shall be free from cracks, crevices and grooves. Weldings should be grinded to $R_a = 0.8$

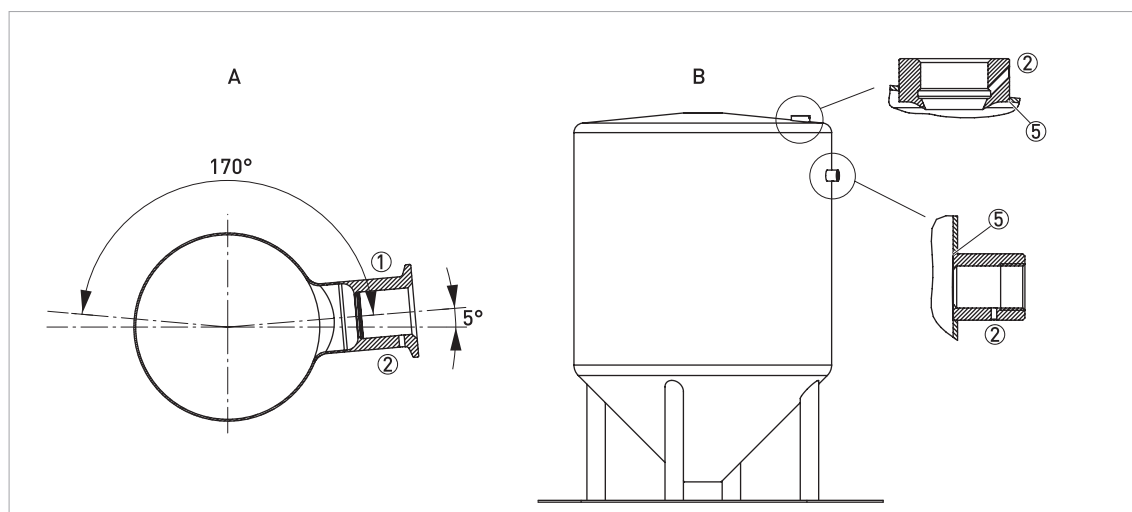

Figure 3-1: Mounting of 3A products in pipe installations (A) or tank installations (B)

3.5 Installation of sliding connection

The following drawing shows how the sliding connection can be used for at least 4 applications:

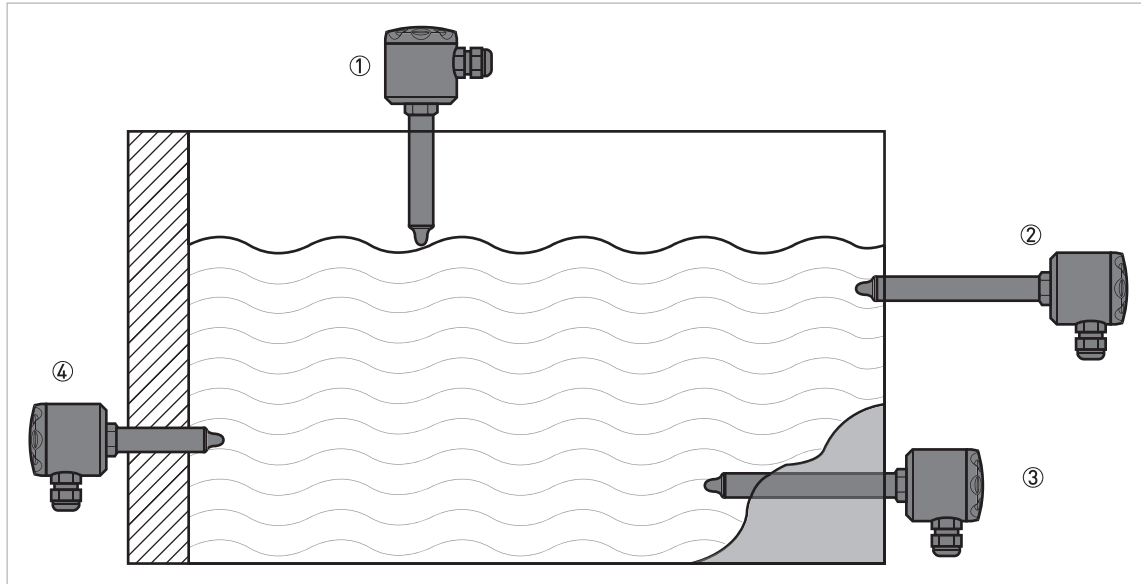

Figure 3-2: Possible applications for sliding connection

- ① Mounted at the top of a tank to adjust to a certain level.
- ② Serving as a cooling neck in high media temperature applications.
- ③ Adjusted to place the sensor tip deeper inside the tank (for lumpy or sticky media).
- ④ To reach in through insulation material.



CAUTION!

The LS 6500 with sliding connection can be mounted with a static pressure up to 16 bar / 232 psi. To prevent personnel injuries, it is essential that the safety chain is mounted correctly and undamaged.



CAUTION!

It is essential that the max. ambient temperature for the electronics is never exceeded.

The operating conditions for the sliding connection in different media temperatures and specified ambient temperatures can be found in the following drawing.

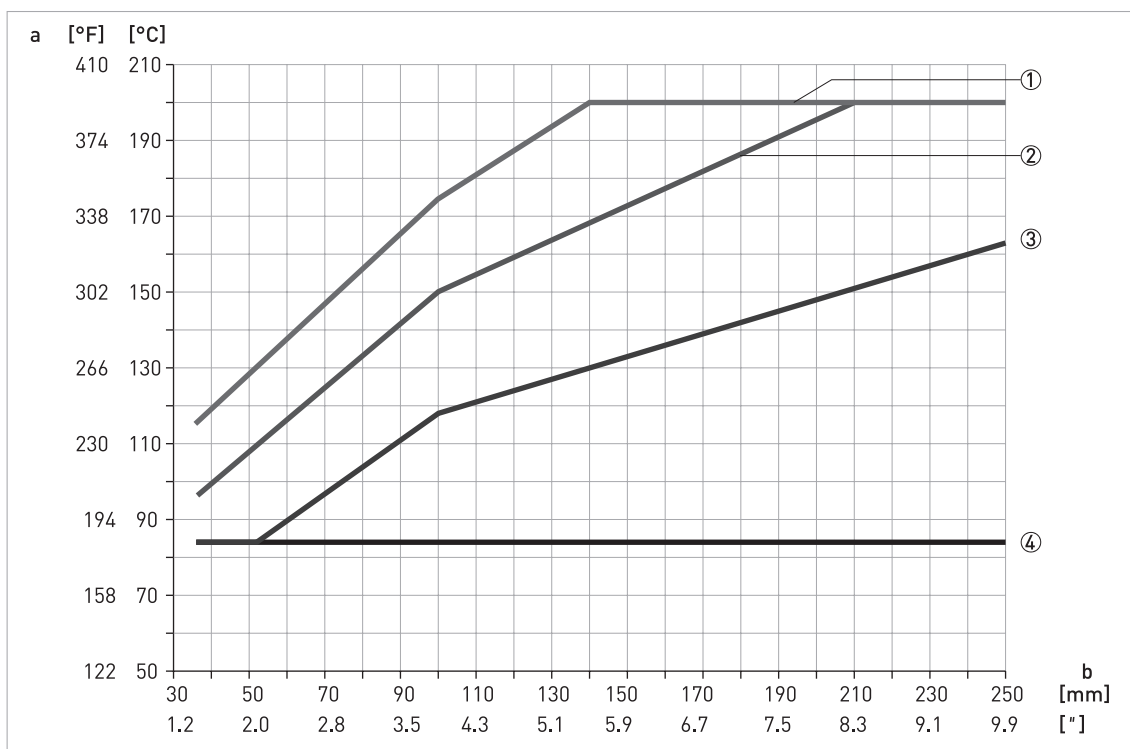

Figure 3-3: Media temperature versus external length of sliding connection

a = media temperature in [°C] or [°F]

b = external length of sliding connection in [mm] or ["]

- ① T_{amb} = max. 40°C / 104°F
- ② T_{amb} = max. 60°C / 140°F
- ③ T_{amb} = max. 75°C / 167°F
- ④ T_{amb} = max. 85°C / 185°F

Example, how to read the drawing:

A 250 mm / 9.9" sliding connection is mounted in a tank with a total insertion length of 150 mm / 5.9". Hence the external length of the sliding connection will be:
 250 - 150 = 100 mm or 9.9 - 5.9 = 4".

The media temperature will be max. 160°C / 320°F.

Read the x-axis at 100 mm / 4" on the y-axis at 160°C / 320°F and find that the ambient temperature must be kept below 40°C / 104°F. In case the radiated heat from the tank will cause a higher ambient temperature at the housing efficient insulation of the tank must be established.

4.1 Safety instructions

**DANGER!**

All work on the electrical connections may only be carried out with the power disconnected. Take note of the voltage data on the nameplate!

**DANGER!**

Observe the national regulations for electrical installations!

**DANGER!**

For devices used in hazardous areas, additional safety notes apply; please refer to the Ex documentation.

**WARNING!**

Observe without fail the local occupational health and safety regulations. Any work done on the electrical components of the measuring device may only be carried out by properly trained specialists.

**INFORMATION!**

Look at the device nameplate to ensure that the device is delivered according to your order. Check for the correct supply voltage printed on the nameplate.

4.2 Description of electrical connection

Terminals 1 and 2 are used for supplying a DC voltage of 12...30 V (M12: terminal 1 and 3). According to polarity, the output will switch to active or inactive when the sensor is immersed (refer to connection diagram). The terminal wired to the negative pole is connected via an internal protective diode to the housing.

The maximum power consumption is 70 mA (excluding load switched). This value should be taken into account in connection with the recommended use of a fuse. An active switching output (PNP) is available at terminal 5 (M12: terminal 4). The switching voltage is a minimum of 1 V below the supply voltage. The maximum output current is 50 mA. At higher loads, the current is limited accordingly. Damage through shorting cannot occur.

**CAUTION!**

When the top cover is removed, do not look directly at the LED with unshielded eyes or damage to retina may occur!

4.3 Electrical connection diagramms

Description of normally open (NO) and normally closed (NC)

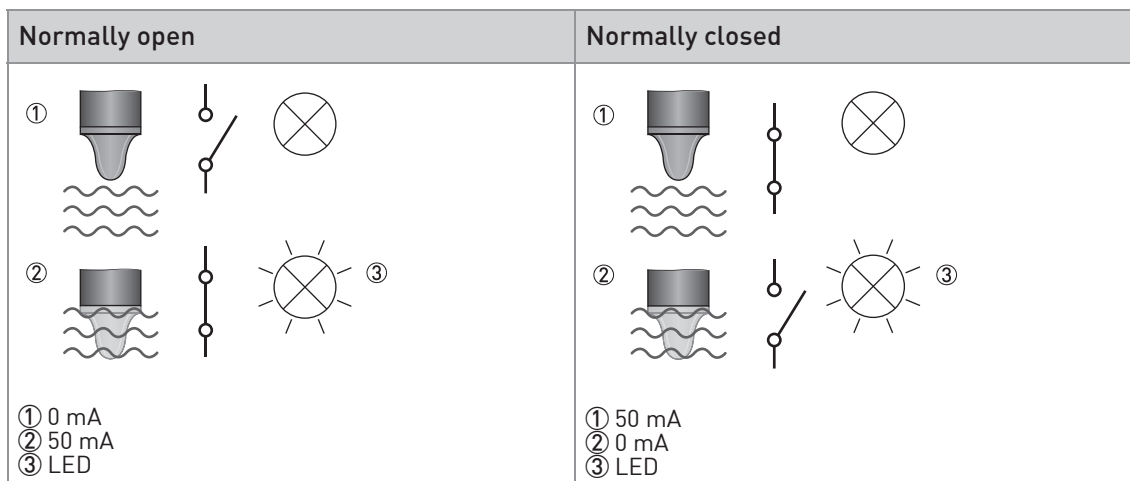

PNP

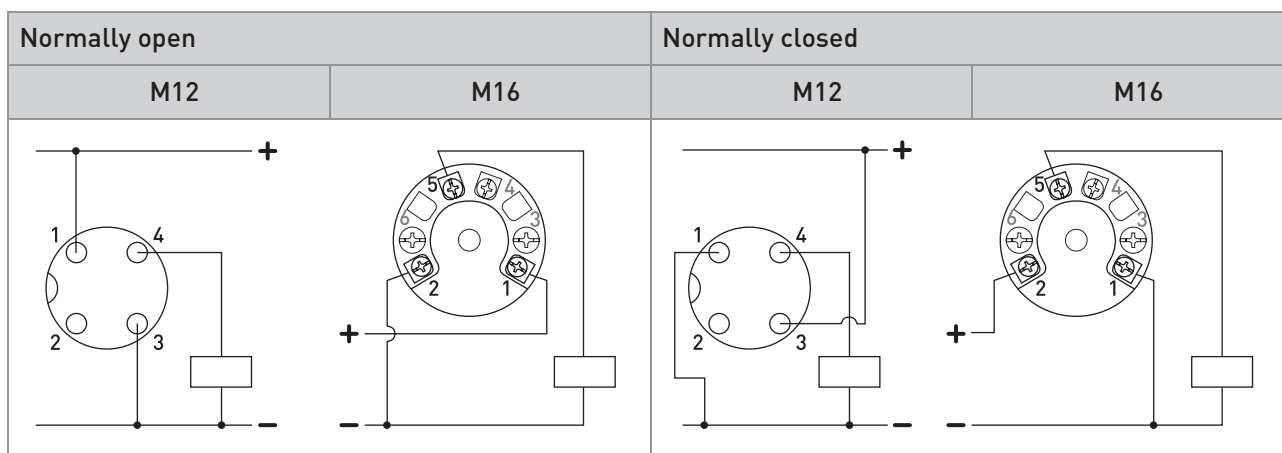

NPN

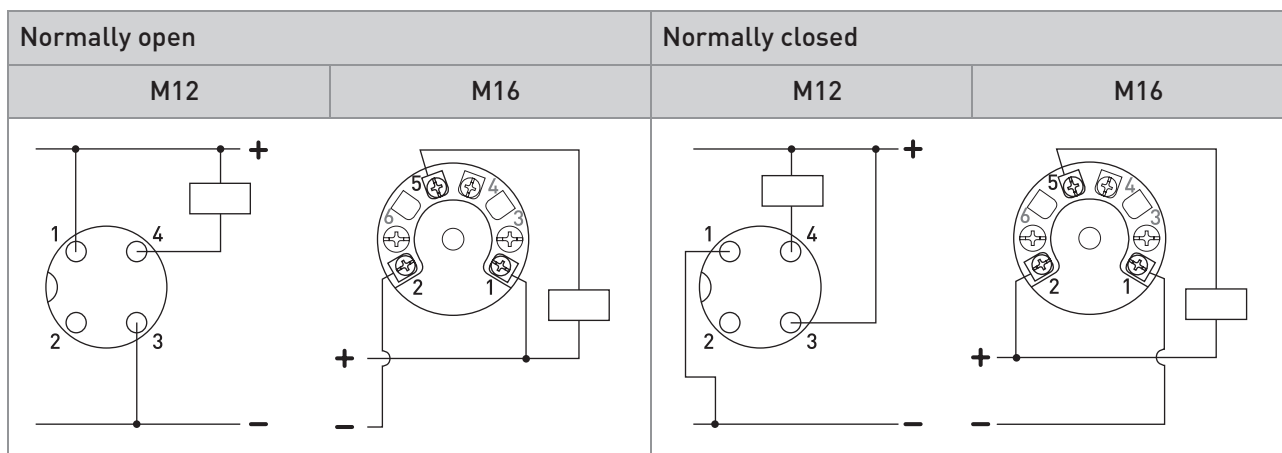

M12 plug

1: brown; 2: white; 3: blue; 4: black

Digital output

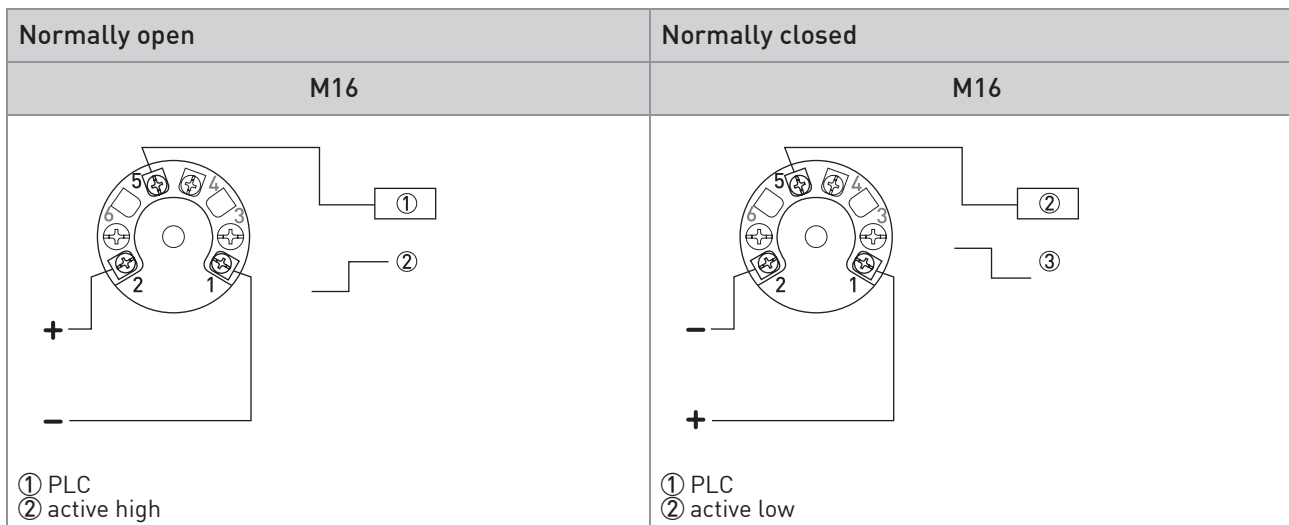

4.4 Electrical connection data for use in hazardous areas

Ex tD A20 IP67 100°C

The LS 6500 must be installed in accordance with prevailing guidelines for zone 20 **without** a barrier.

Supply range: 12...30 VDC, max. 100 mA

Temperature class: T100; refer to following table

Ex nA II T 5 (pending)

The LS 6500 must be installed in accordance with prevailing guidelines for zone 2 **without** a barrier.

Supply range: 12...30 VDC, max. 100 mA

Temperature class: T1...T5; refer to following table

Ex ia IIC T5 (pending)

The LS 6500 must be installed in accordance with prevailing guidelines for zone 0 **with** a barrier.

A certified Ex ia or isolation barrier with the max. values

$U_{\max} = 30$ VDC,

$I_{\max} = 0.1$ A,

$P_{\max} = 0.75$ W

must be used.

Supply range: 12...30 VDC, max. 100 mA

Temperature class: T1...T5; refer to following table

Connection type	T _{amb}		Max. medium temperature		Note
	[°C]	[°F]	[°C]	[°F]	
Standard and DN38 connection	-40...+85	-40...+185	+85	+185	-
	-40...+60	-40...+140	+95	+203	①
	-40...+40	-40...+104	+115	+239	①
Sliding connection 100 mm / 3.9"	-40...+85	-40...+185	+85	+185	-
	-40...+60	-40...+140	+150	+302	①
	-40...+40	-40...+104	+175	+347	①
Sliding connection 250 mm / 9.8"	-40...+85	-40...+185	+85	+185	-
	-40...+60	-40...+140	+195	383	①
	-40...+40	-40...+104	+200	+392	①, ②

① If the sensor tip at the device is the only part in contact with the media.
② Max. allowed medium temperature.

4.5 Configuration tool

The configuration tool can be ordered optionally to configure the LS 6500 switches.

Scope of delivery:

- Interface unit
- CD with software and product drivers (DTM)
- USB cable
- Cable with 2 alligator clips

The configuration tool connects the LS 6500 with a computer. With the corresponding software, it is possible to get an online communication with the LS 6500.

By using this tool, device information like serial number, switching point range and tag numbers are displayed on the computer. Settings as switching point, damping, polarity and output can be changed.

Self-learning function for the contact output is possible as well as reset function to the default values of the switching point.

By fine-tuning of the switching point settings, LS 6500 could differentiate between various products which are covering the sensor. In other words, the device could be set to trigger on a specific product and ignore a second product. Basis for this would be a different ϵ_r value of these two products.

**DANGER!**

Disconnect the power supply before connecting the configuration tool to the switch!

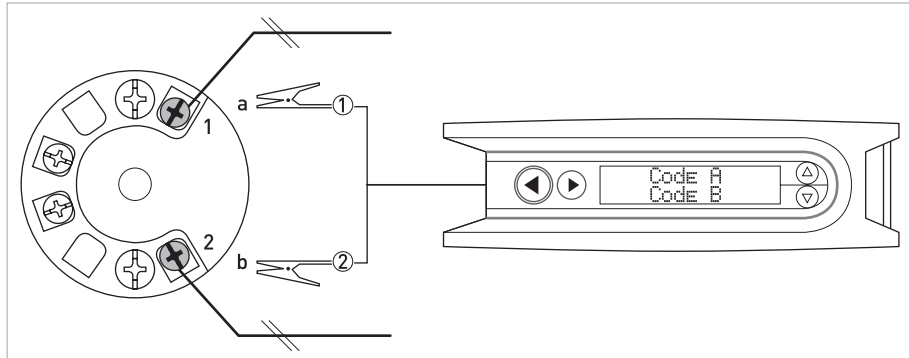

Figure 4-1: Electrical connection of configuration tool

a = red alligator clip

b = black alligator clip

**INFORMATION!**

Ambient temperature range is 0...+50°C / +32...+122°F.

**DANGER!**

The configuration tool cannot be connected to the LS 6500 within the hazardous area. For programming, remove the device out of this area.

4.6 Teach-In function

A Teach-In procedure may be necessary for a medium with a low dielectric constant.

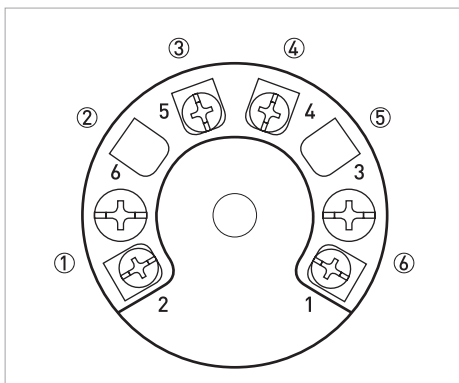

- ① 12...36 VDC / - or (+)
- ② Sensor
- ③ Output
- ④ Teach-In
- ⑤ Cover
- ⑥ 12...36 VDC / + or (-)

Step	Action	LED	Result
1	Connect terminal "Teach-In" to -VDC (T1 or T2) for 3.5 s.	Flash 1 time per second.	Ready for Teach-In.
2	With "no media present" connect "Teach-In" to -VDC shortly.	Light for 2 seconds and then flash.	Register "empty" state. If the media is sticky, foamy, powdery or in other ways leaving parts of the media at the sensor tip this situation has to be established also during the Teach-In process. Otherwise a faulty calibration can be the result.
3	With "media present" connect "Teach-In" to -VDC shortly.	Light for 2 seconds.	Register "full" state, store and return to normal operation with the new settings

If the media is sticky, foamy or powdery or in other ways leaving parts of the media at the sensor tip, this situation has to be established also during the Teach-In process.

**CAUTION!**

- *Make sure that power is on before Teach-In.*
- *For best Teach-In it is important that the actual process conditions are simulated.*
- *During Teach-In mode the light intensity of the LED will decrease to protect your eyes.*

If Teach-In for some reason do not succeed, the device will enter "Error State" and reload factory settings automatically. This state is indicated by a blinking LED (3 short and 1 long blink). The error can normally be fixed by powering off and on. Alternatively remake the "Teach-In" procedure.

The factory settings can always be reloaded by connecting the terminal "Teach-In" to -VDC for more than 6.5 s. The reloaded factory settings will be confirmed by pulsing light intensity 3 times.

**INFORMATION!**

Please observe that the LS 6500 has been factory adjusted to measure liquids with $\epsilon_r > 2$, such as oil.

In case the media has a lower ϵ_r value (e.g. powder) either a Teach-In procedure must be carried out for the media or alternatively a manual adjustment using the configuration tool can be done. The adjustment must be made at the medias operating temperature to avoid faulty measurements due to temperature drift.

5.1 Start-up

Before connecting to power, please check that the system has been correctly installed. This includes:

- The device must be mechanically safe and mounted in compliance with the regulations.
- Check the leak-tightness at the sleeve.
- Make sure that the cable gland is tight or, as the case may be, the M12 plug is properly screwed down.
- The power connections must have been made in compliance with the regulations.
- Check that the electrical operating data of the power supply are correct.



- Switching on the power.
- Check for correct switching function.

5.2 Fault diagnosis and corrective action

Fault	Cause	Action / elimination
LED not "on"	Sensor cap not in contact with liquid product	-
	Supply voltage < 12 V, permittivity too low	Measure voltage at Pin 1 and 2 (M12: pin 1 and 3)
No switching output	Cable break	Check continuity of cables
	Incorrect polarity of supply	Reverse terminals 1 and 2 (M12: terminal 1 and 3)
	Short-circuit	Check wiring

6.1 Availability of services

The manufacturer offers a range of services to support the customer after expiration of the warranty. These include repair, maintenance, technical support and training.



INFORMATION!

For more precise information, please contact your local sales office.

6.2 Spare parts and accessories

This device contains no replaceable parts. In case of malfunction the device must be returned to the manufacturer. Refer also to chapter "Returning the device to the manufacturer".

Accessories

Designation	Type
Weld-in sleeve	HWN 200
Liquiphant adapter sleeve G1", shape "G"	HLM 200
Liquiphant assembly kit Rd 52, shape "F"	HLS 210
Varivent flange version N	HVF 250
Sanitary pipe assembly kit DN25	HMT 225
Sanitary pipe assembly kit DN50	HMT 250
Tri-Clamp flange 2", DN50 DIN 32676, ISO 40/51 mm	HTC 250

6.3 Returning the device to the manufacturer

6.3.1 General information

This device has been carefully manufactured and tested. If installed and operated in accordance with these operating instructions, it will rarely present any problems.



CAUTION!

Should you nevertheless need to return a device for inspection or repair, please pay strict attention to the following points:

- *Due to statutory regulations on environmental protection and safeguarding the health and safety of our personnel, manufacturer may only handle, test and repair returned devices that have been in contact with products without risk to personnel and environment.*
- *This means that the manufacturer can only service this device if it is accompanied by the following certificate (see next section) confirming that the device is safe to handle.*



CAUTION!

If the device has been operated with toxic, caustic, flammable or water-endangering products, you are kindly requested:

- *to check and ensure, if necessary by rinsing or neutralising, that all cavities are free from such dangerous substances,*
- *to enclose a certificate with the device confirming that is safe to handle and stating the product used.*

6.3.2 Form (for copying) to accompany a returned device

Company:		Address:	
Department:		Name:	
Tel. no.:		Fax no.:	
Manufacturer's order no. or serial no.:			
The device has been operated with the following medium:			
This medium is:	water-hazardous		
	toxic		
	caustic		
	flammable		
	We checked that all cavities in the device are free from such substances.		
	We have flushed out and neutralized all cavities in the device.		
We hereby confirm that there is no risk to persons or the environment through any residual media contained in the device when it is returned.			
Date:		Signature:	
Stamp:			

6.4 Disposal



CAUTION!

Disposal must be carried out in accordance with legislation applicable in your country.

7.1 Measuring principle

A high frequency signal sweep is radiated from the sensor tip into the tank / pipe. The medium will act as a virtual capacitor, which together with a coil in the sensor head, will form a circuit creating the switching point signal. This virtual capacity will depend of the dielectric value of the medium and it is well defined for most media.

The measurement is precise and unaffected by the mounting position.

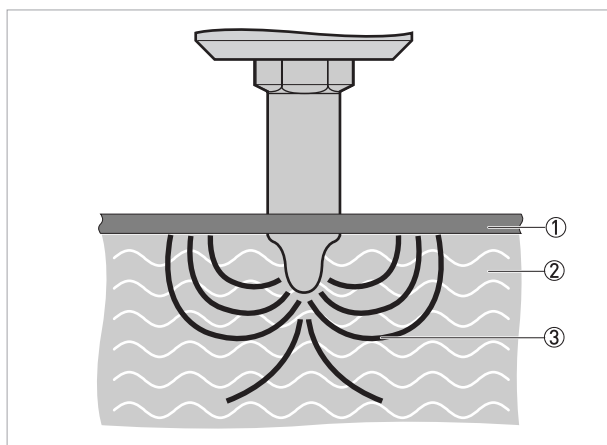

- ① Tank wall / pipe wall
- ② Medium
- ③ Line of electric flux

7.2 Technical data



INFORMATION!

- The following data is provided for general applications. If you require data that is more relevant to your specific application, please contact us or your local sales office.
- Additional information (certificates, special tools, software,...) and complete product documentation can be downloaded free of charge from the website (Download Center).

Measuring system

Measuring principle	Electromagnetic wave, 100..180 MHz
Application range	Level detection, dry-run protection and media separation of liquids and solids.

Design

Construction	The measurement system consists of a measuring sensor and the electronic unit which is available in a compact version. The switching point is signalled by a blue LED indication through the housing cover.
Options	Sliding connection / extension for high-temperature applications Teach-In function for applications where the medium is hard to detect.
Accessories	Comprehensive range of adapters and process connections for hygienic installation. Please refer to the specific data sheet "Accessories".

Measuring accuracy

Resolution	±1 mm / ±0.04"
Hysteresis	±1 mm / ±0.04"
Reference conditions acc. to EN 60770	
Temperature	+20°C ±5°C / +70°F ±10°F
Pressure	1013 mbar abs. ±20 mbar / 14.69 psig ±0.29 psig
Relative air humidity	60% ±15%

Operating conditions

Temperature	
Ambient temperature (T _{amb})	-40...+85°C / -40...+185°F
Process temperature	-40...+85°C / -40...+185°F (short version and DN38 connection) < 1 hour, T _{amb} < 60°C / 140°F: -40...+140°C / -40...+284°F -40 ...+200°C / -40...+392°F (with sliding connection)
Pressure	
Ambient pressure	Atmosphere
Process pressure	Standard and DN38 connection: max. 40 bar / 580 psi Sliding connection: max. 16 bar / 232 psi
Other conditions	
Protection category (acc. to EN 60529)	IP67 equivalent to NEMA 4X

Installation conditions

Installation	In any position. For detailed information refer to chapter "Installation".
Dimensions and weights	For detailed information refer to chapter "Dimensions and weights".

Materials

Sensor housing	Stainless Steel 1.4301 / 304
Process connection	Stainless Steel 1.4404 / 316L
Sensor insulation	Virgin PEEK, FDA conform
Electrical connection	Cable gland M16: Plast or Nickel-plated brass
	Plug M12: Nickel-plated brass

Process connections

Standard	Hygienic G½; DN38
Other	For other hygienic process connections, e. g. Tri-clamp, 11851, Varivent see data sheet "Accessories".

Electrical connections

Power supply	Non-Ex / Ex nA: 12...36 VDC, 70 mA max.
	Ex: 12...30 VDC, 70 mA max.
Power consumption	1.7 W
Power-up time	< 2 s
Reaction time	Max. 0.1 s
Damping	0...10 s
Cable entry	M16 cable gland or M12 (4 pole Lumberg)

Output

Output (active)	Max. 50 mA, short-circuit and high-temperature protected
Output type	PNP, NPN or digital output
Output polarity	See drawing in chapter "Electrical connection".
Active "Low"	NPN and digital output; $[-VDC + 2.5 V] \pm 0.5 V$; $R_{load} = 1 k\Omega$
Active "High"	PNP and digital output; $[VDC - 2.5 V] \pm 0.5 V$; $R_{load} = 1 k\Omega$
Factory settings	Measure: $\epsilon_r > 2$; damping: 0.1 s

Approvals and certifications

CE	This device fulfils the statutory requirements of the EC directives. The manufacturer certifies successful testing of the product by applying the CE marking.
ATEX	ATEX II 1G Ex ia IIC T5 (pending)
	ATEX II 3G Ex nA II T 5 (pending)
	ATEX II 1D Ex tD A20 IP67 100°C
Other standards and approvals	
Electromagnetic compatibility (EMC)	EN 61326
Vibration resistance	IEC 68-2-6, GL test 2 (standard and DN38 connection)
Hygiene	3A for G½ and DN38, FDA conform materials

7.3 Dimensions and weights

$G\frac{1}{2}$ " hygienic connection, DN38 hygienic connection and $G\frac{1}{2}$ " hygienic sliding connection (from left to right)

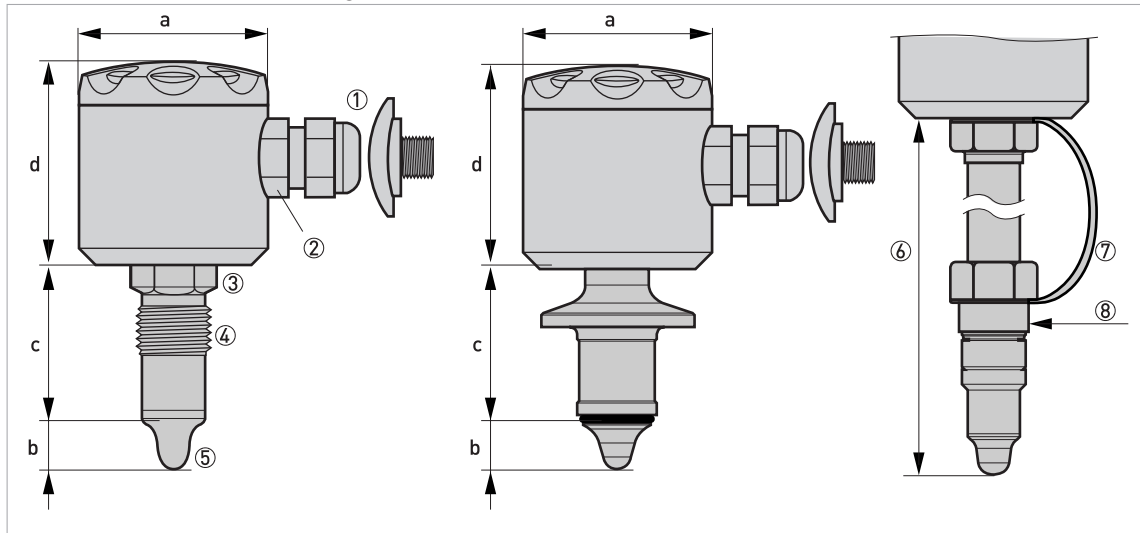

- ① M12x1 plug
- ② M16x1.5 cable gland
- ③ WS 22
- ④ $G\frac{1}{2}$ "
- ⑤ PEEK tip
- ⑥ Sliding connection length (refer to ordering data)
- ⑦ Safety chain
- ⑧ $G\frac{1}{2}$ " hygienic sliding nipple

	Dimensions		Approx. weight	
	[mm]	[inches]	[kg]	[lb]
$G\frac{1}{2}$" hygienic connection				
a	Ø55	Ø2.17	0.4	0.9
b	18	0.71		
c	44	1.73		
d	58	2.28		
DN38 hygienic connection				
a	Ø55	Ø2.17	0.4	0.9
b	31.5	1.20		
c	19	0.70		
d	58	2.28		

The weight for devices with sliding connection depends on the ordered length of the sliding connection (max. 0.5 kg / 1.1 lb).

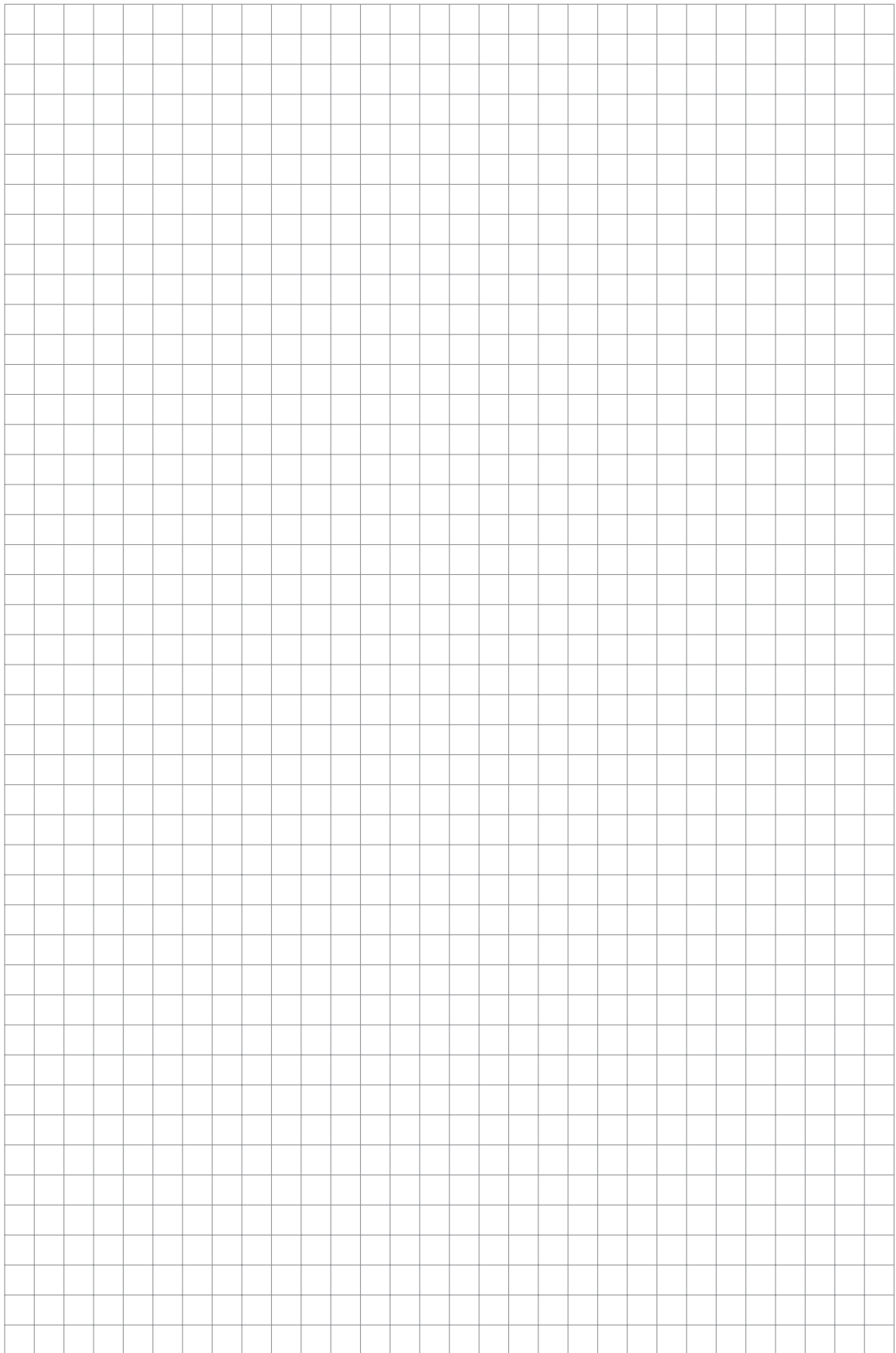





KROHNE product overview

- Electromagnetic flowmeters
- Variable area flowmeters
- Ultrasonic flowmeters
- Mass flowmeters
- Vortex flowmeters
- Flow controllers
- Level meters
- Temperature meters
- Pressure meters
- Analysis products
- Products and systems for the oil & gas industry
- Measuring systems for the marine industry

Head Office KROHNE Messtechnik GmbH
Ludwig-Krohne-Str. 5
47058 Duisburg (Germany)
Tel.: +49 (0)203 301 0
Fax: +49 (0)203 301 10389
info@krohne.de

The current list of all KROHNE contacts and addresses can be found at:
www.krohne.com

KROHNE