

Installation and Operating Instructions

OPTISENS AAC 050

Measuring and control instruments
for potentiostatic measurements
of Chlorine, total Chlorine, Chlorine dioxide,
Oxygen, Ozone and Hydrogen peroxide



Content

0.	Introduction.....	4
0.1	General	4
0.2	Legal matters	4
0.3	Safety	5
0.3.1	Documentation symbols.....	5
0.4	Features	6
0.4.1	Device	6
0.4.2	Controller.....	6
0.4.3	Connections	6
1.	Mechanical installation	7
1.1	Installation of panel-mounting converters	7
1.2	Installation of wall-mounting converters.....	8
2.	Electrical connection.....	9
2.1	Connection diagram panel-mounting converter.....	10
2.2	Connection diagram wall-mounting enclosure.....	11
3.	Operation of the device.....	12
3.1	How to adjust parameters	12
3.1.1	Selection between alternatives	12
3.1.2	Adjustment of numerical parameters	13
3.2	Menu Overview	13
3.2.1	Main menu and basic settings	13
3.3	Password and language	14
3.3.1	Enter password	14
3.3.2	Language	14
4.	Adjustments for the measurement	14
4.1	Configuration of the converter.....	15
4.2	Calibration	15
4.3	Temperature compensation	16
4.3.1	Calibration of the temperature measurement	16
4.4	Automatic Sensor Cleaning ASR (option).....	17
5.	Adjustments of the controller.....	17
5.1	ON/OFF controller.....	18
5.2	P / PI controller as impulse-frequency controller	19
5.3	P / PI controller as pulse-pause controller	20
5.4	Activation and deactivation of the controller	21
5.5	Turn-on delay	21
5.6	External controller stop	21
5.7	Manual operation of the relays.....	22
5.8	Limit values	23
5.8.1	Turn-on delay	23
5.9	Dosage check	23
6.	Alarm.....	24
6.1	Error messages.....	25
7.	Output.....	26
7.1	Current output	26
7.2	Serial interface RS485 (option).....	26
8.	Operation and maintenance	27
8.1	Maintenance of the device	27
8.2	Display contrast	27
8.3	Exchange fuse	27
8.4	Cleaning	27
8.5	Maintenance of the potentiostatic measurement	27
8.6	Disposal	27
8.7	Service	28
8.7.1	Product info.....	28
8.7.2	Analog inputs	28
8.7.3	Erase settings (reset).....	28
9.	Technical data.....	29
9.1	Technical data.....	29
9.2	Dimensions	30

9.2.1	Panel-mounting enclosure	30
9.2.2	Wall-mounting enclosure	30
10.	Device return form	31
11.	Customer settings - for reference	32

0. Introduction

0.1 General

This manual applies to the following devices:

Device and type	revision date
AAC 050 R	05 / 08
AAC 050 W	05 / 08

It contains technical information for the installation, start-up and maintenance. If you have any questions not included in this manual please contact your supplier or the official representative of KROHNE Water Solutions in your country.

0.2 Legal matters

Authorized personnel

Installation, connection, adjustment, start-up, and maintenance of the device are carried out by authorized personnel with adequate qualification.

Liability

Responsibility as to suitability and intended use of these devices rests solely with the user. Improper installation and operation may lead to loss of warranty. In addition, KROHNE Group's Standard General Conditions of Sale and Delivery, found on the back of the invoice and forming the basis of the purchasing contract, are applicable.

General limitation on liability

Unless otherwise expressly set forth in the Standard Terms and Conditions of Sale and Delivery, the Seller is only liable for damages, whatever their legal basis is, in case they are based on willful action or gross negligence. This limitation on liability does not apply in the event the Buyer raises claims relating to personal injury or damages to property according to the product liability law based on a defect of the delivered goods.

Any advice given by the Seller, in particular regarding the application of the delivered goods, shall only commit the Seller if given or confirmed in writing.

Returning the device

If you need to return the level gauge to the manufacturer or supplier, please read to the instructions and complete the form given in the appendix.

Warranty

Please consult KROHNE Water Solutions General Terms and Conditions for information on guarantee and liability.

0.3 Safety

Please check for damages immediately after receiving the devices and report any damages within 24 hours to the delivering company. Never work with a damaged device.

Keep this manual at a safe place where you can always look up the safety instructions and the information on handling and usage.

This device was designed and built according to the safety measurements for electronic devices and has left our company in perfect working condition. To preserve this condition and to ensure safe usage follow all instructions carefully and pay special attention to all warnings issued in this manual. If the device is visibly damaged or has been stored inappropriately or if there are any doubts concerning safe usage, shut it down and make sure it cannot be restarted by accident.

0.3.1 Documentation symbols

A set of symbols is used to give warnings or information relevant to particular applications. These are defined below:



Caution / Attention

Information that, if not followed, may lead to actions resulting in incorrect functioning of the device.



Warning

Information that, if not followed, may lead to actions resulting in measurement error, personal injury and/or damage to the device.

NOTE

Is used to highlight interesting details.

0.4 Features

0.4.1 Device

Measuring ranges	0.00...4.00 mg/l	Cl ₂	free Chlorine
	0.00...20.00 mg/l	Cl ₂	free Chlorine
	0.00...4.00 mg/l	O ₃	Ozone
	0.00...4.00 mg/l	TCI ₂	total Chlorine
	0.00...4.00 mg/l	ClO ₂	Chlorine dioxide
	0.00...20.00 mg/l	O ₂	Oxygen
	0.000...9.999 mg/l	O ₂	Oxygen
	0.0...100.0 mg/l	H ₂ O ₂	Hydrogen peroxide
Temperature range	-30.0...+140.0°C		
Flow	5.0...30.0 l/h		
Display	measured value with unit; temperature with unit; status display sensor, calibration, controller & alarm		
Temperature compensation	manual or automatic with Pt100 or NTC		
Calibration	1-point calibration; calibration in air for Oxygen		
Cleaning (option)	Automatical recognition if connected		

0.4.2 Controller

Set points	2 set points with adjustable direction
Controller types	ON/OFF controller with hysteresis P controller as Pulse-Pause-, Impulse-Frequency- or steady controller PI controller as Pulse-Pause-, Impulse-Frequency- or steady controller
Hysteresis	adjustable within the measuring range
P range X _P	adjustable within the measuring range
Integral time T _N	0...2000 s
Least pulse	0.1...9.9 s
Pulse+ pause time	02...99 s
Impulse frequency	00...72 equiv. to 0...7200 pulses/h
Turn-on delay	0...200 s
Alarm function	min. and max. limit and onset delay, power failure alarm,
Dosage control	0... 90 min

0.4.3 Connections

Relays	3 potential-free contacts (2x controller, 1x alarm) 6 A, 250 V, max. 550 VA
Analog output	1x 0/4...20 mA galvanically isolated max. loading 500 Ohm
Analog inputs	1 measuring input for Cl ₂ , TCl ₂ , ClO ₂ , O ₂ , O ₃ or H ₂ O ₂ , 1 measuring input for Pt100 or NTC
Digital input	external controller stop or lack-of-water indication
Serial interface (Option)	RS485, Baud rate 9600, data format 8 Bit, 1start and 1stop bit, no parity

1. Mechanical installation

On Chapter 9.2 you will find detailed instructions for the installation.

For panel-type meters you have to prepare an opening of 92 x 92 mm / 3.6" x 3.6". Install the device and fix it with the two mounting clips which were part of the delivery.

You can install devices in wall-mounting enclosures either by hanging them upon the center slot or by sliding the slot under a screw, which is an alternative for limited space. Either way you have to fix it additionally with two screws.

Install the device in a place where it is not put under mechanical or chemical strain!



ATTENTION

Mind the protection class:

- Panel mounting version: IP 54 (front), IP 30 (Housing)
- Wall mounting version: IP 65 (closed terminal cover)

1.1 Installation of panel-mounting converters

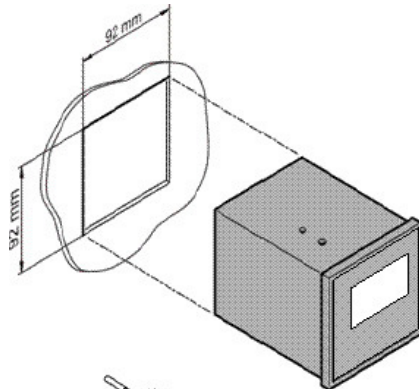

Prepare an opening of 92 x 92 mm / 3.6" x 3.6".

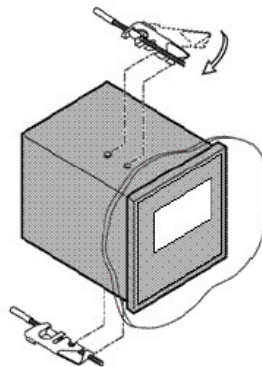

Install the device from the front side and fix it with the two mounting clips which were part of the delivery.

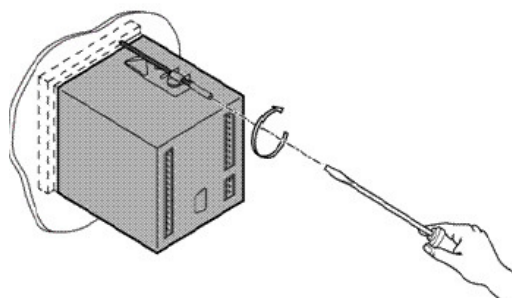

Screw tight until the device is fixed perfectly.

1.2 Installation of wall-mounting converters

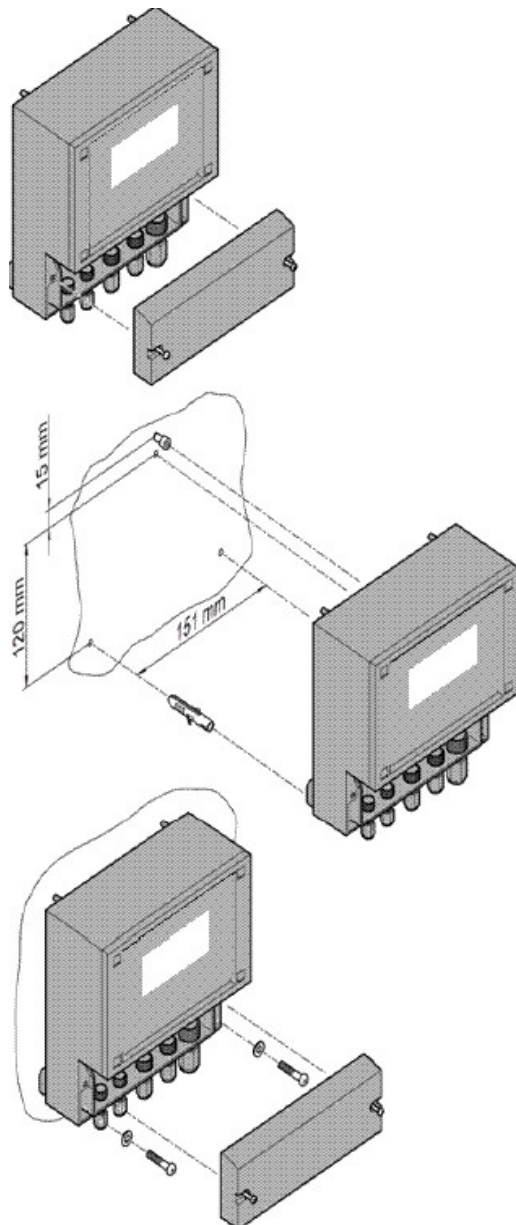

Unscrew the terminal cover.

Drill three holes (max. M5) according to the drawing. Mind that there are two ways for installation:

- (1) You can hang the device upon the upper screw. In that case drill the upper hole 120mm / 4.7" above the lower two.
- (2) Or you can slip the fixture on the back of the device under the upper screw. In that case the upper hole has to be another 15mm / 0.6" higher.

Insert the upper screw and make sure to leave at least 3 mm between wall and screw head for the fixture.

Mount the device and fix it with the two lower screws. Close the terminal cover or start with the connections.

2. Electrical connection

You will find a detailed connection diagram on the following pages.

Before connecting the power supply check the information on the nameplate of the device!



ATTENTION

Input, output and control lines must be installed separate from each other and separate from power lines!

For inputs and outputs use screened lines and connect the screen on one side only.

The potentiostatic measurement is interference-sensitive, especially when using membrane sensors. Use a special screened cable. Membrane sensors are delivered complete with cable.

When using the relays, mind that with inductive loads, interference must be suppressed. If that is not possible, the relay must be protected at the terminal block in the converter by a resistance-capacitance filter or, in case of direct current, by a free-wheeling diode.

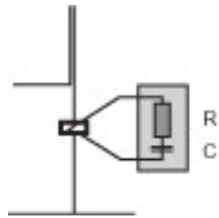

Current up to	Capacitor C	Resistance R
60 mA	10 nF 260 V	390 Ohm 2 Watt
70 mA	47 nF 260 V	22 Ohm 2 Watt
150 mA	100 nF 260 V	47 Ohm 2 Watt
1.0 A	220 nF 260 V	47 Ohm 2 Watt

2.1 Connection diagram panel-mounting converter

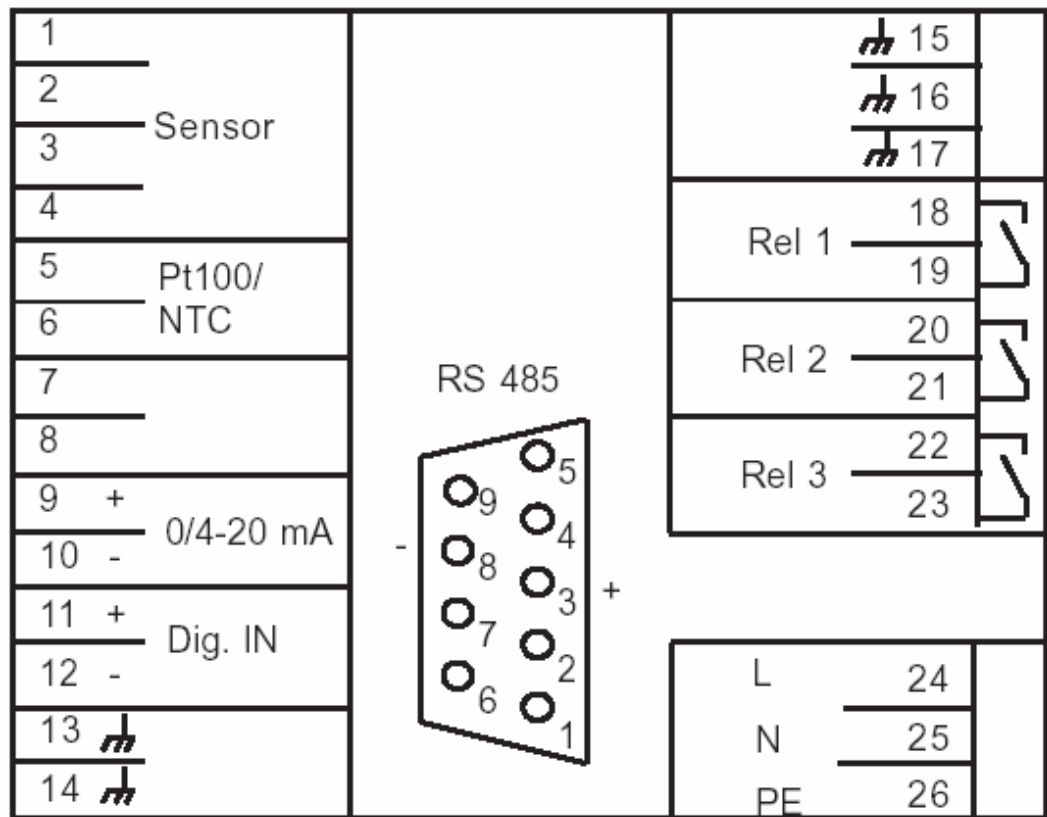

Connection	Terminals	Notes
Metal electrodes & membrane sensors without electronics	1- 4	1 = screen 2 = measuring electrode 3 = reference electrode 4 = counter electrode With 2-electrode sensors bridge 3 + 4
Membrane Sensor with electronics	1 - 4	1 + 2 = measurement 3 = - 6V 4 = + 6V
Pt100/NTC	5 + 6	
Analog output	9 + 10	9 = +, 10 = -, max. burden 500 Ohm
Digital input	11 + 12	11 = +, 12 = -, external controller stop or lack-of-water sensor or flow-meter Flow measurement: 11 = white, 12 = brown
Relay 1	18 + 19	
Relay 2	20 + 21	
Relay 3	22 + 23	Alarm Relay
Power supply	24+25+26	check information given on nameplate
RS485 (option)	Sub-D Sub-D 4/7	3 = +, 8 = - bridged = terminating impedance activated

2.2 Connection diagram wall-mounting enclosure

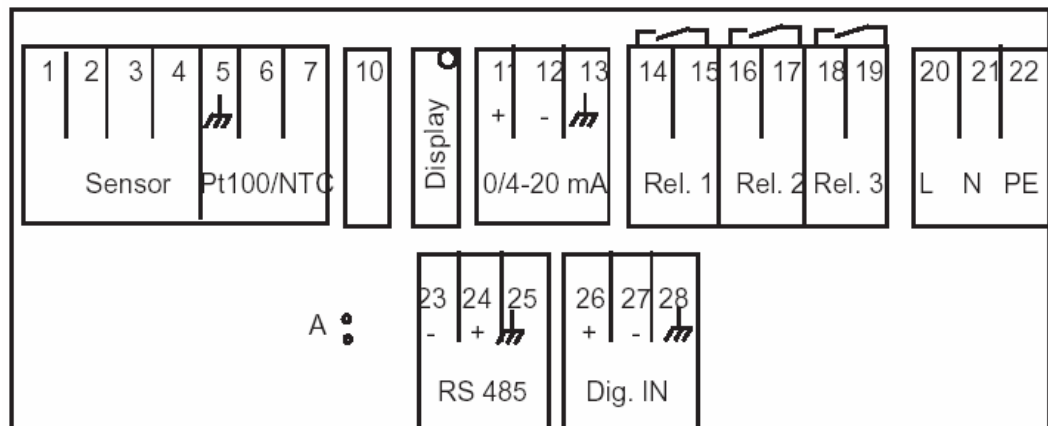

Connection	Terminals	Notes
Metal electrode & membrane sensors without electronics	1 - 4	1 = screen 2 = measuring electrode 3 = reference electrode 4 = counter electrode With 2-electrode sensors bridge 3 + 4
Membrane sensors with electronics	1 - 4	1 + 2 = Measurement 3 = - 6V 4 = + 6V
Pt100 / NTC	6 - 7	
Display contrast	Display	Potentiometer to adjust the display contrast
Analog output	11 + 12	11 = +, 12 = - ; max. burden 500 Ohm
Relay 1	14 + 15	
Relay 2	16 + 17	
Relay 3	18 + 19	Alarm relay
Power supply	20+21+22	check information given on nameplate
RS 485 (option)	23 + 24	23 = -, 24 = +,- Jumper A bridged = terminating impedance activated
Digital input	26 - 27	26 = +, 27 = -, external controller stop or lack of water sensor or flow meter Flow measurement: 26 = white, 27 = brown

3. Operation of the device

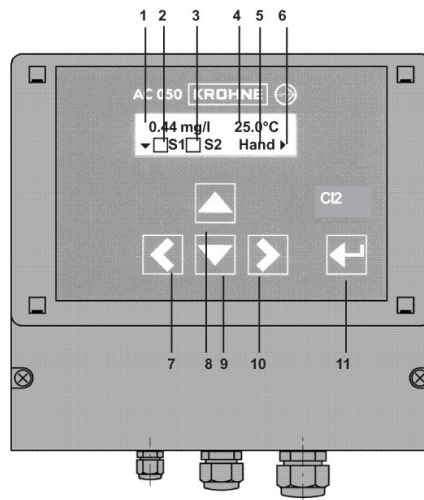

- 1 Measured value
- 2 Status relay 1
- 3 Status relay 2
- relay OFF
- relay ON
- 4 Temperature
- 5 Controller
- AUTO: controller ON
- MAN : controller OFF (manual operation of the relays)
- 6 Orientation aids
- 7 Key left (◀)
- 8 Key up (▲)
- 9 Key down (▼)
- 10 Key right (▶)
- 11 Key "Enter"

When turned on the device shows the measured values of conductivity and temperature together with the controller mode (Man) and the status of the relays S1 and S2 (both OFF).

With five membrane keys you can move within the menu:

- With key ▼ you enter the main menu.
- With keys ▲ and ▼ you move up and down in the menu.
- With key ▶ you address a menu or parameter.
- With key ◀ you leave a menu without storing
- With key "Enter" changes are stored.

For your convenience arrows in the display indicate the directions you can take from your position in the menu.

3.1 How to adjust parameters

Temp. comp.
▶ Manual.

1) When you address a parameter the actual setting is displayed.

Temp. comp.
▶ Auto

2) Switch to the next alternative setting with key ▶ .

Temp. comp.
▶ Manual.

3) When you have come to the last alternative, pressing the key once more will bring you back to the start.

3.1.1 Selection between alternatives

For many parameters you have the choice between two or more alternatives, for e. g. between manual and automatic temperature compensation. For these parameters you need only key ▶ . Switch from one alternative to the next until you either come back to where you started or until you reach the alternative you were looking for.

With these parameters any changes are immediately valid - there is no need to store the change.

Enter password
▶ 058

Enter password
◀ 058 †

Enter password
▶ 062

- 1) Address the parameter with key ▶ .
- 2) A double arrow appears behind the number indicating that the number can be changed now with keys ▲ and ▼ .
- 3) Store the new value with key „Enter“. The double arrow disappears - the new value is stored.

3.1.2 Adjustment of numerical parameters

Numerical parameters can only be altered when a double arrow is visible behind the number. This double arrow appears when you address the parameter with key ▶ .

Adjust the parameter with keys ▲ and ▼ . A short pressure on the key changes the last decimal by 1. If you keep the key pressed, the value will continue changing until the pressure is released.

Store the changes with key „Enter“. The double arrow disappears.

3.2 Menu Overview

1.48 mg/l 25.0°C
 S1 S2 Auto
 ▼

Main menu

Calibrate
 Temp. comp.
 Enter password
 Set points
 Limit values
 Basic settings
 Service

Display of the measured values

Press key ▼ to enter the main menu.

- Calibration function (only for pH measurements)
- Temperature compensation (only for pH measurements)
- Password function
- Controller settings - set points, P ranges, I functions
- Alarm function

Basic settings

▶

Cal. Pt/NTC
 Contr. settings
 Turn-on delay
 Analog outputs
 Language
 Bus address
 Flow alarm
 Averaging
 Temp. Coeff.
 Cleaning

All parameters which are set just once at the beginning can be found in the menu "basic settings"

3.2.1 Main menu and basic settings

The parameters are sorted into two menus: In the main menu you will find all functions which are used regularly, such as calibration. The menu basic settings contains all parameters which are set just once during start-up.

On the following pages you will find information on how to adjust parameters and which parameters you need for which application, in the following order:

- 1) General adjustments: password and language
- 2) Adjustments for measurement: calibration, temperature compensation, flow measurement and automatic sensor cleaning
- 3) Adjustments of the controller: selection of the controller version and corresponding parameters
- 4) Adjustments to read out data: analog, digitally and/or as alarm

3.3 Password and language

Main menu

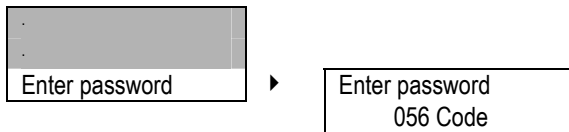

3.3.1 Enter password

To get access to the various parameters you have to enter the correct password:

- Code 11 gives access to the parameters „calibration“, „temperature compensation“, and „set points“.
- Code 86 gives access to all parameters and functions.

With any other number it is impossible to select, view or change any parameter.

Main menu

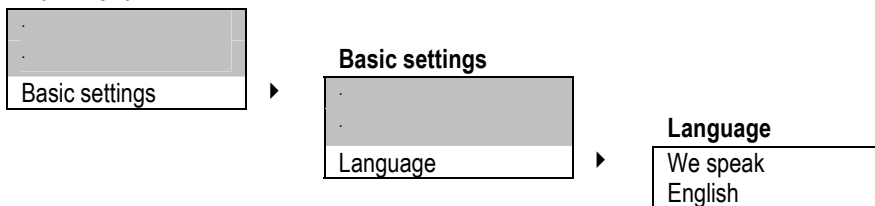

3.3.2 Language

For the communication with the device you can choose from a variety of languages.

Since choosing a language is part of the basic settings, it requires code 86. If a different code is set, you will be asked to enter the correct password.

4. Adjustments for the measurement

Main menu

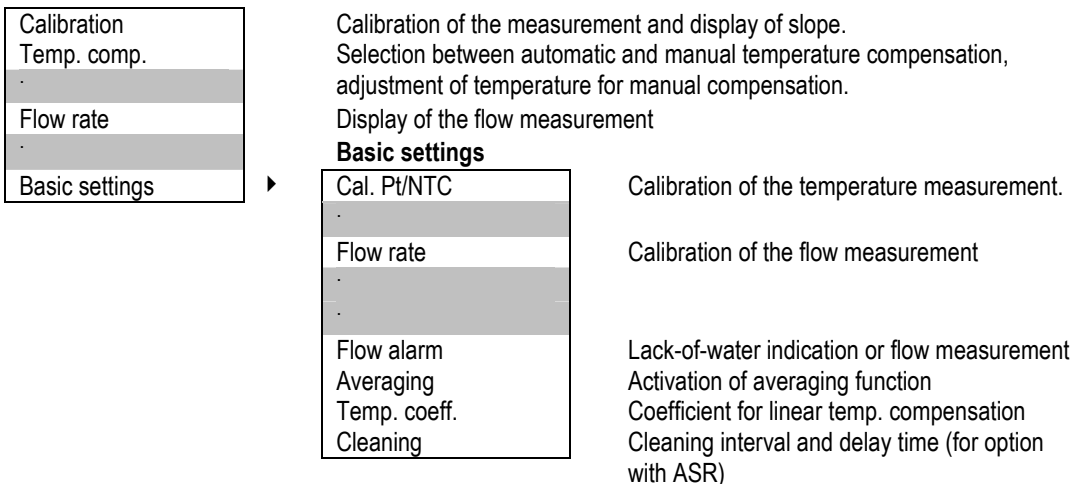

Potentiostatic measurements require a 1-point calibration:

Since the measurement depends upon the flow-rate and calibration solutions would not be stable anyway, the sensor cannot be taken out of the armature for calibration, as is done with pH sensors. Instead the actual concentration of the test water is determined by an alternative method, for example photometrically with DPD, and this value is entered as calibration value. Calibration of the Oxygen measurement is simpler, using the Oxygen concentration of the ambient air.

The measurement is influenced by temperature. This influence can be compensated manually or automatically. For manual compensation the temperature is entered manually, for automatic compensation temperature has to be measured with a temperature sensor.

4.1 Configuration of the converter

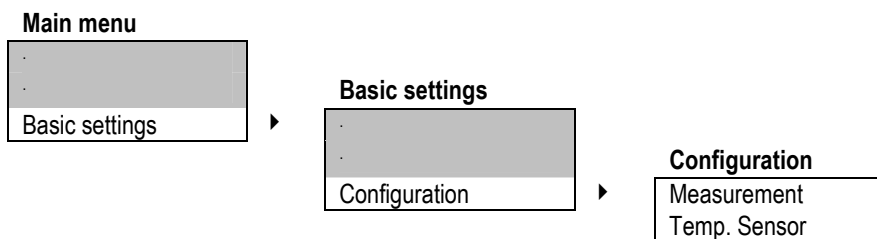

The instruments AC050 POT provide two measuring inputs.
Input 1 can work with the following sensors:

Parameter		Measuring range
Free Chlorine	Cl2	0.00...4.00 mg/l
Free Chlorine	Cl2	0.00...20.00 mg/l
Chlorine dioxide	ClO2	0.00...4.00 mg/l
Ozone	O3	0.00...4.00 mg/l
Total Chlorine	TCI	0.00...4.00 mg/l
Oxygen	O2 HAZ	0.00...20.00 mg/l
Oxygen	O2 HA	0.000...9.999 mg/l
Hydrogen peroxide	H2O2	0.0...100.0 mg/l

Input 2 works with the temperature sensors Pt100 or NTC.

4.2 Calibration

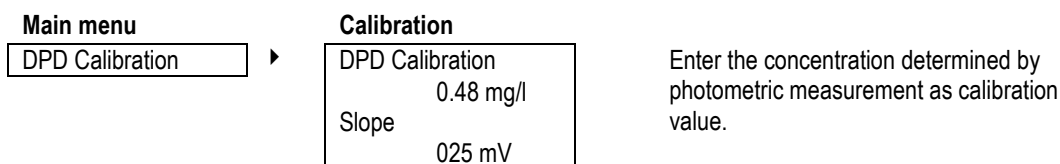

Calibration of the measurement of Cl2, TCl2, ClO2, O3 and H2O2

- 1) Switch off the controller. Take a sample of the test water flowing out of the armature and determine the concentration by photometric DPD measurement or a similar reference method.
- 2) Enter the determined concentration and calibrate by pressing keys ▶ and ◀: Start with key ▶ and then - while still applying pressure on this key - additionally press key ◀.
- 3) Check the displayed slope before switching on the controller.

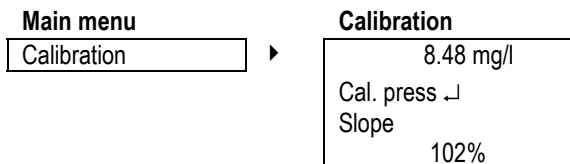

The Oxygen concentrations in ambient air are stored - You do not need to enter anything.

Calibration of the Oxygen measurement

The Oxygen measurement is calibrated in water-saturated air.

- 1) Switch off the controller. Take the sensor out of the armature, dry the sensor tip carefully with a napkin, hold it in the air above water with the membrane pointing down and wait until the reading is stable.
- 2) Calibrate by pressing key ↵
- 3) Check the displayed slope, put the sensor back in the armature, wait until the reading is stable, then switch the controller on again.

NOTE The Oxygen measurement strongly depends on temperature. Make sure that automatic calibration is selected during calibration.

4.3 Temperature compensation

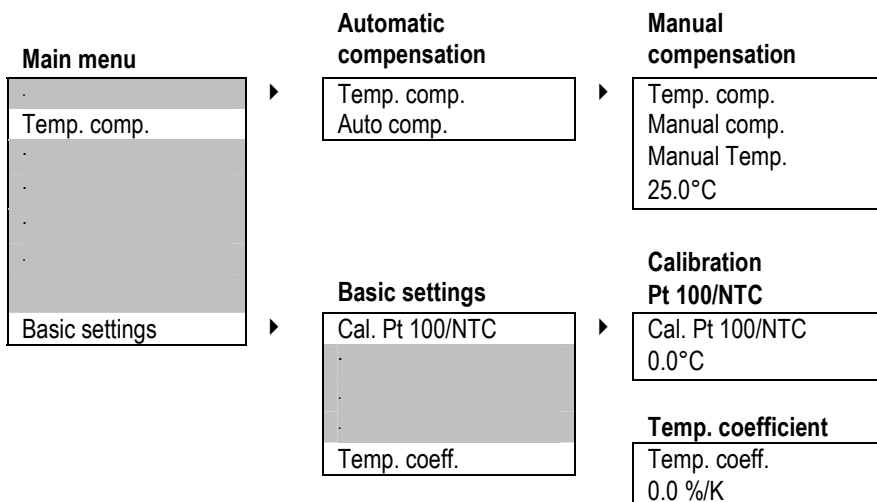

Select between two ways of compensation:

- 1) **Automatic compensation** with temperature sensor
Mind that the temperature sensor should always measure the temperature around the conductivity sensor. When conductivity sensor and temperature sensor are not immersed in the same solution, better switch to manual compensation.
- 2) **Manual compensation**
If the temperature can be regarded as constant, you can enter the temperature manually instead of measuring it continuously. The device will then compensate the temperature error of this temperature.

4.3.1 Calibration of the temperature measurement

When using a 2-wire connection for the temperature sensor, please check the temperature measurement in the beginning. If the displayed temperature differs from the real temperature, enter the deviation as correction in the basic settings. This correction will be added to all temperature measurements. If your calibration was correct, the temperature displayed is now equal to the real temperature.

4.4 Automatic Sensor Cleaning ASR (option)

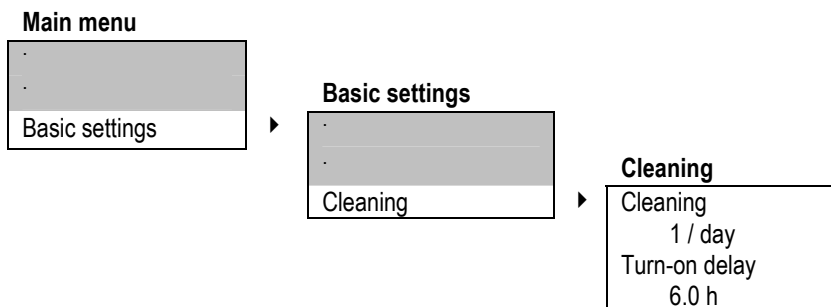

The patented Automatic Sensor Cleaning ASR prevents staining and passivating coatings and keeps the surface of metal sensors clean throughout the measurement.

The cleaning is an electrochemical one: in adjustable intervals the instrument applies a strong voltage to the electrode to produce Hydrogen and Oxygen from the surrounding water. This method needs no addition of chemicals. Both Hydrogen and Oxygen are ORP active substances that will destroy inorganic coatings such as rust, manganese oxide, or lime, and organic coatings such as fat or grease.

Activate the cleaning after completing the set-up to conserve the clean metal surface of the new sensor during subsequent measurements.

The cleaning process takes about 30 seconds. During this time measurement is not possible, and after cleaning the sensor needs some time for polarisation. Therefore the display and the analog output will show the last measured value for five minutes, and the message „cleaning in progress“ is displayed. As a safety measure, attempts to calibrate within these five minutes are ignored.

Activation and timing

The cleaning is activated by setting the cleaning function from 0/day (never) to 1/day (every 24h) or 2/day (every 12 h). The first cleaning starts as soon as the function is activated, and subsequent cleanings are carried out after 24h, or 12h, according to settings.

NOTE Often it is convenient to carry out the cleaning during the night. Therefore we have added a delay function that enables you to set the time for the cleaning to a later hour. If, for example, you select 1 cleaning per day at 10am and set the delay time to 12h, cleaning takes place every day at 10pm.

NOTE The device does not contain a real-time clock. Therefore all time settings have to be repeated after power failure or disconnection of the power supply.

NOTE Whenever the instrument indicates „no water“, cleaning is not carried out.

5. Adjustments of the controller

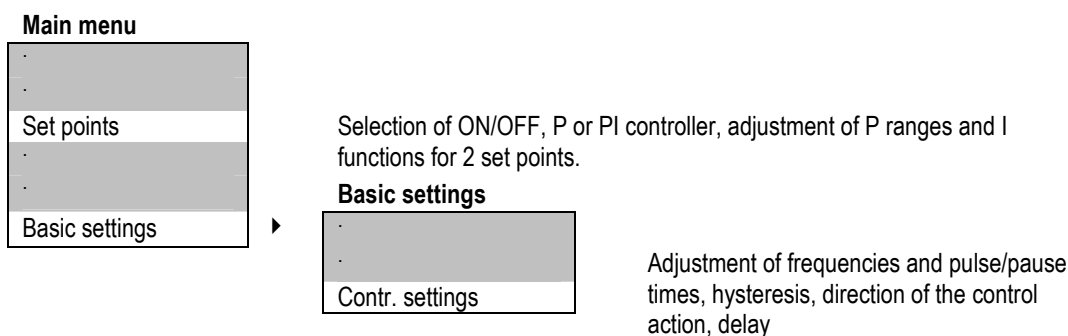

For any type of controller you have to enter one or two set points, and you have to tell the device whether these set points are reached by increasing or decreasing the measured value.

You can choose between three different controller versions:

ON/OFF controller

The ON/OFF controller switches ON if the measured value exceeds the set point and OFF if it drops back below it or vice versa. Dosage is always carried out with 100% (ON) or 0% (OFF). The parameter for an ON/OFF controller is the hysteresis.

P controller

The P controller or proportional controller reduces the dosage in the vicinity of the set point proportional to the control deviation. This is easily achieved if the analog output is used as steady control output. If the relays are used, the proportional reduction is achieved by either reducing the switch frequency (Impulse-frequency controller) or reducing the time within a given period of time in which the relay is ON (pulse-pause controller). The parameters for a P controller are the P range and the impulse- frequency or the pulse+ pause time and the minimum pulse.

PI controller

The PI controller is a P controller with an additional I function. Adjustments and parameters are the same as for a P controller. Additionally the integral action time has to be adjusted which determines the I function. The I function eliminates the P controller's disadvantage of a remaining steady-state deviation.

5.1 ON/OFF controller

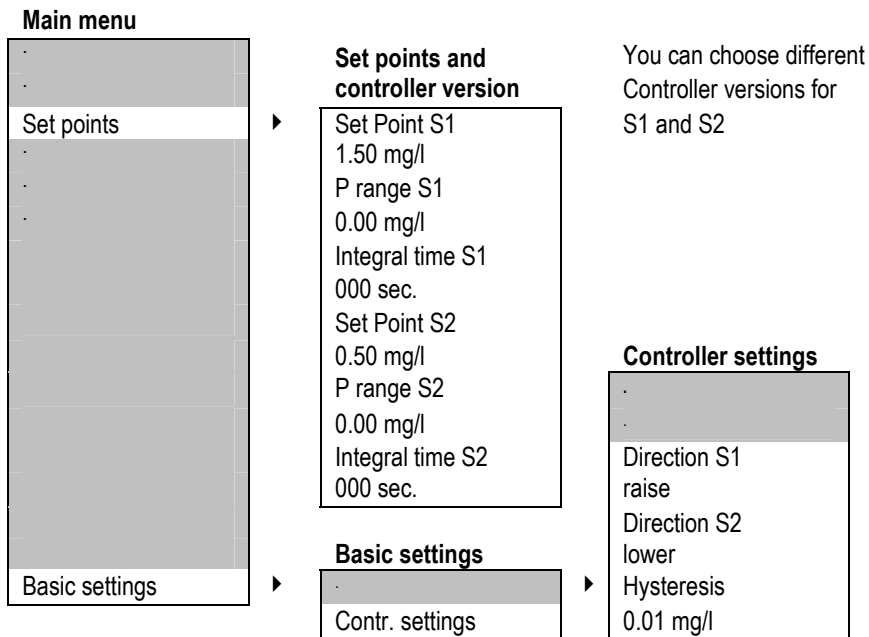

For an ON/OFF controller you have to set the following parameters:

1) Set points S1 and S2

Set point S1 refers to relay 1, set point S2 refers to relay 2.

2) P range and integral action time for S1 and S2

For an ON/OFF controller set P range = 0 and integral time = 0.

3) Acting direction for S1 and S2

Select "raise" if the dosage raises the measured value.

Select "lower" if the dosage lowers the measured value.

4) Optionally a hysteresis

The hysteresis prevents fast switching in the vicinity of the set point. If hysteresis is activated (by setting a value > 0) the relay switches only when the set point is exceeded by half the hysteresis.

5.2 P / PI controller as impulse-frequency controller

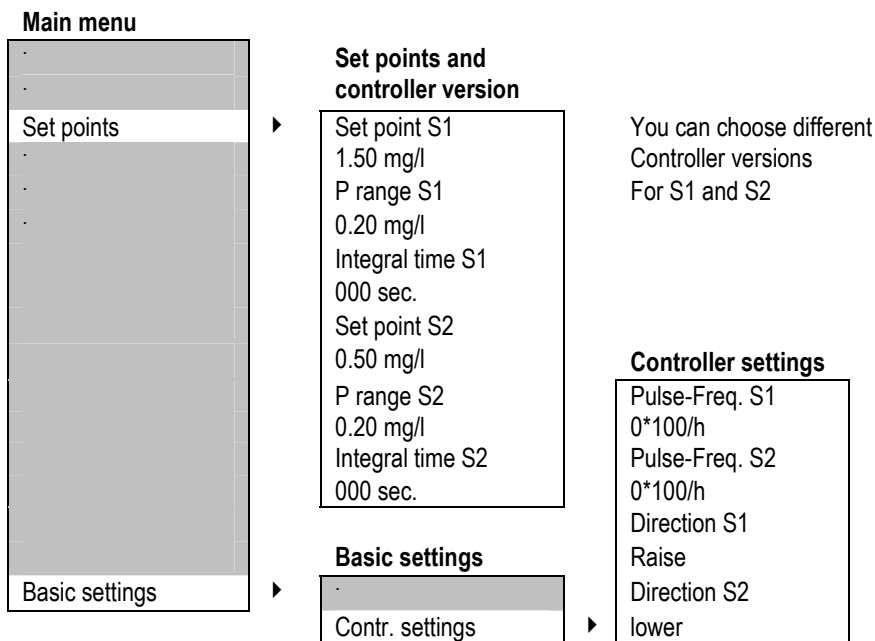

For an impulse-frequency controller you have to set the following parameters:

1) Set points S1 and S2

S1 refers to relay 1, S2 refers to relay 2.

2) P range and integral action time for S1 and S2

Adjust a P range > 0. For a P controller set integral time = 0, for a PI controller set an integral time > 0.

3) The acting direction for S1 and S2

Select „raise“ if the dosage raises the measured value.

Select „lower“ if the dosage lowers the measured value.

4) Pulse-frequencies for S1 and S2

Enter the maximum pulse-frequency that corresponds to 100% dosage.

5.3 P / PI controller as pulse-pause controller

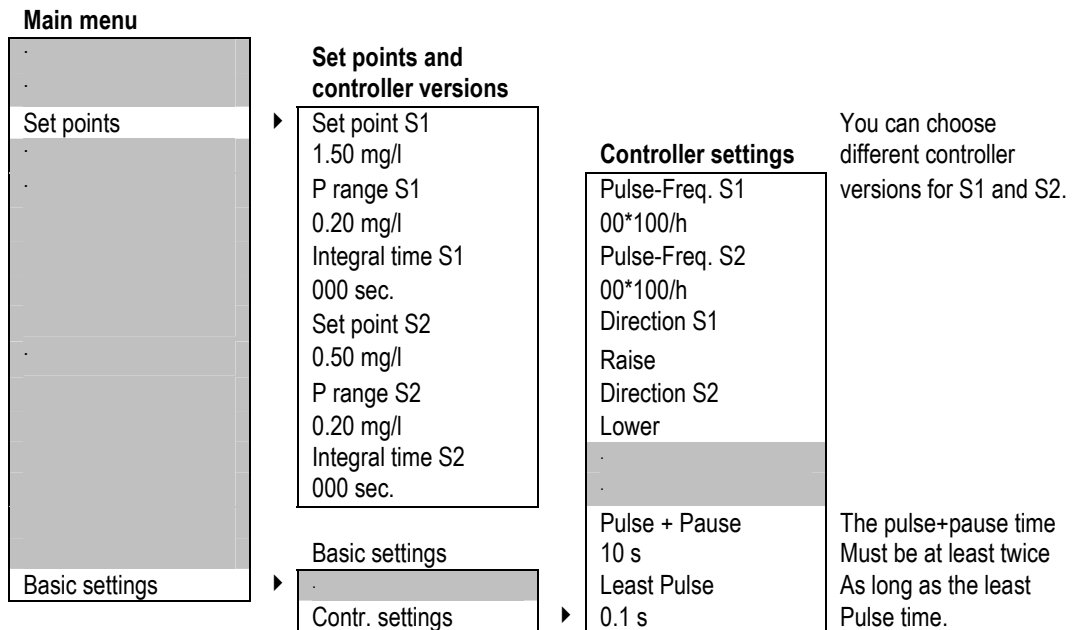

For a pulse-pause controller you have to set the following parameters:

1) Set points S1 and S2

S1 refers to relay 1, S2 refers to relay 2.

2) P range and integral action time

Adjust a P range > 0. For a P controller set integral time = 0, for a PI controller set an integral time > 0.

3) Pulse-frequencies for S1 and S2

Both frequencies must be set to 00, otherwise the controller will act as an impulse-frequency controller.

4) The acting direction for S1 and S2

Select „raise“ if the dosage raises the measured value.

Select „lower“ if the dosage lowers the measured value.

5) Pulse + pause time

Define a period of time during which the relay is proportionally to the control deviation ON (pulse) or OFF (pause), respectively.

6) Least pulse time

Set a minimum pulse time that the relay has to at least remain open to allow the actuator to react.

5.4 Activation and deactivation of the controller

The controller is activated and deactivated from the main display without any menus. Press key ▶ to switch from Manual Mode (controller OFF) to Automatic Mode (controller ON) and vice versa. The actual mode is indicated in the display.



CAUTION

Make sure that the controller is deactivated before connecting dosing pumps or other actuators!

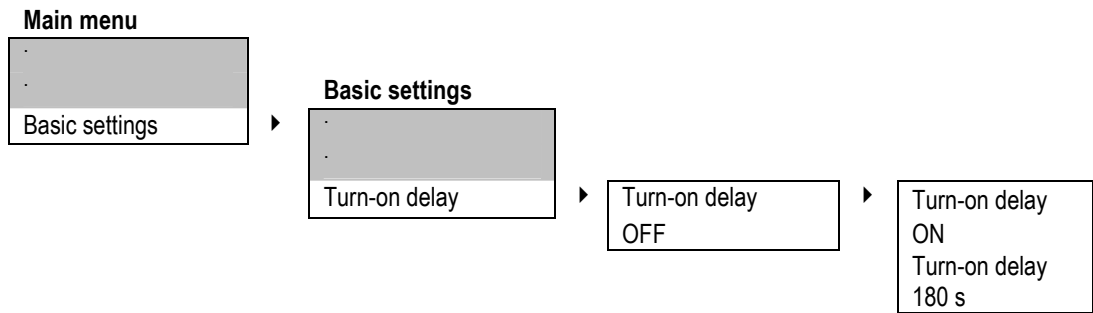

5.5 Turn-on delay

Set a delay time which has to pass before the controller is activated after start-up or power interrupt. This allows the measurement to settle and prevents inappropriate dosage of chemicals.

5.6 External controller stop

You can activate or deactivate the controller with an external switch by using the digital input. This feature requires no settings or adjustments. If the digital input is short-circuited, the controller stops, and the message „external controller stop“ appears in the display.

NOTE

This feature can also be used as lack-of water indication. Just connect a level sensor to the digital input.

5.7 Manual operation of the relays

1.402 mS	25.0°C
▼ <input type="checkbox"/> S1 <input type="checkbox"/> S2 Auto ←	

1) If the controller is ON, switch it OFF with key ← .
Instead of „Auto“ the display shows „Man“.

1.402 mS	25.0°C
↑ <input type="checkbox"/> S1 <input type="checkbox"/> S2 Man ←	

1.402 mS	25.0°C
↑ ← <input type="checkbox"/> S1 <input type="checkbox"/> S2 Man	

2) Switch to the operation mode of S1 with key ▲ .
The square to the left of S1 starts to flash.

1.402 mS	25.0°C
↑ ← <input checked="" type="checkbox"/> S1 <input type="checkbox"/> S2 Man	

3) Switch ON relay 1 with key ← .
The square to the left of S1 gets dark.

1.402 mS	25.0°C
↑ ← <input type="checkbox"/> S1 <input type="checkbox"/> S2 Man	

4) Switch OFF relay 1 again with key ← .
The square gets light.

1.402 mS	25.0°C
↑ ← <input type="checkbox"/> S1 <input type="checkbox"/> S2 Man	

5) Switch to the operation mode of S2 with key ▲ .
The square to the left of S2 starts to flash.

1.402 mS	25.0°C
↑ ← <input type="checkbox"/> S1 <input checked="" type="checkbox"/> S2 Man	

6) Switch ON relay 2 with key ← .
The square to the left of S2 gets dark.

1.402 mS	25.0°C
↑ ← <input type="checkbox"/> S1 <input type="checkbox"/> S2 Man	

7) Switch OFF relay 2 again with key ← .
The square gets light.

1.402 mS	25.0°C
↑ <input type="checkbox"/> S1 <input type="checkbox"/> S2 Man ←	

8) Leave the operation mode of relay 2 with key ▲ .
Both squares appear light, none flashes - You have left the operation mode.

For manual operation you need no menu.

- With key ← you switch OFF the controller.
- With key ▲ you switch between Manual operation <> operation mode S1 <> operation mode S2 <> manual operation.
- In the operation mode you can switch ON and OFF the selected relay with key ← .
- A flashing square indicates that the relay is in operation mode.
- A dark square indicates that the relay is switched ON.
- A light square indicates that the relay is switched OFF.

If you switch ON a relay it stays ON until you switch it OFF again manually!



WARNING

5.8 Limit values

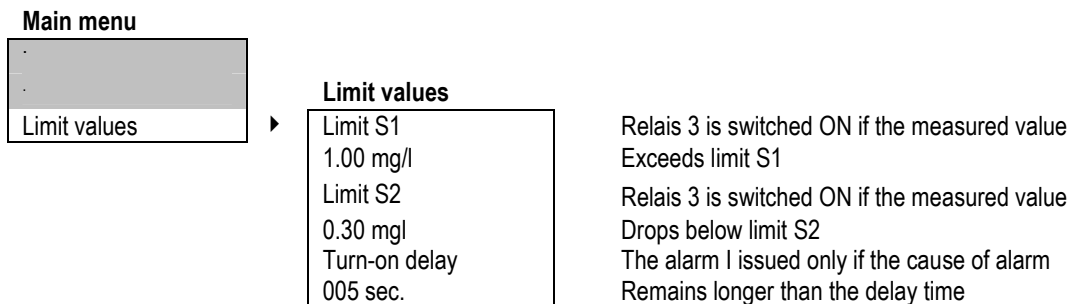

For the alarm, you can adjust two limits:

- Limit 1 is an upper limit. If the measured value exceeds limit 1, an alarm is issued.
- Limit 2 is a lower limit. The alarm is issued if the measured value drops below limit 2.

In case of alarm the display shows the message „limit 1“ (or 2, respectively) and relay 3 is switched ON. This relay can be used to activate an external horn or lamp.

NOTE The limit function is active only if the controller is set on automatic mode. When you switch the controller to MAN, the alarm is extinguished.

5.8.1 Turn-on delay

In some applications it happens regularly that the measured value exceeds a limit for a short period of time. To avoid having an alarm issued under these circumstances you can adjust a turn-on delay which has to pass before an alarm is issued. If the turn-on delay time is >0 then the alarm is issued only if the cause of alarm remains longer than the specified turn-on delay time.

5.9 Dosage check

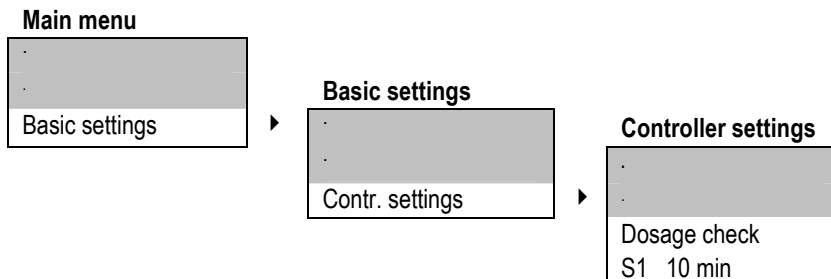

In the basic settings of the controller you can define, how long a controller is supposed to dose with 100% without raising alarm.

If the controller output is 100% for more than the specified time, this is interpreted as an indication of failure, and the device issues an alarm and deactivates the controller, thus stopping further dosage.

The dosage check is a safety catch to prevent hazardous chemicals to be set free in case of a defective dosing tube or tube connection.

NOTE In case of an alarm due to dosage check, only the controller concerned is deactivated.
NOTE If you set the dosage check time to 0 seconds, the dosage check function is deactivated.

6. Alarm

Additional to the limit function the device provides various check functions that raise alarm.

In case of an alarm, relay 3 switches, undelayed, and the cause of the alarm is indicated in the display.

If the cause of alarm is such that control is no longer possible or might even be dangerous, the controller is automatically deactivated until the alarm is switched off.

Switching off the alarm is done automatically by the device as soon as the cause of alarm is eliminated.

Sensor check during calibration

If a sensor gives unsatisfying results during calibration, an alarm is issued. The alarm is held until a new calibration shows satisfying sensor data. In case of calibration failure the controller is not deactivated, to enable you to continue the dosing or treatment process until a replacement sensor is at hand.

Sensor check during measurement

During measurement all connected sensors are checked. If an analog input does not receive a correct signal, for e. g. if a cable is broken or a sensor damaged, an alarm is issued, and the controller deactivated. Alarm and controller stop remain until the analog input receives correct signals again.

Dosage control

If a controller output is 100% longer than the defined dosage time, an alarm is issued, and the corresponding controller is deactivated. The alarm remains until the controller output drops below 100% - it can also be extinguished by setting the controller to manual mode.

Cause of alarm	only active in AUTO mode	deactivates controller
Slope error	no	no
Error input 1	no	yes
Error input 2	no	yes
Limit	yes	no
Dosage	yes	yes

6.1 Error messages

Error message	Cause	Action
Slope error	The slope determined by calibration was higher than 200% or lower than 20 %.	Please check the sensor connection and cable, the flow, and the temperature sensor and settings. Then repeat the calibration. If the error message remains, the sensor has to be cleaned, regenerated, or replaced.
Error input 1	The measuring sensor gives no signal.	Please check the connections, the cable and the sensor for signs of damage.
Error input 2	The temperature sensor gives no signal.	Please check the connections, the cable and the sensor for signs of damage. This message also appears if automatic temperature compensation was selected although no temperature sensor was used.
Limit 1 / 2	The measured value exceeded limit 1 (or dropped below limit 2, respectively).	Please check the dosing and readjust the control parameters, if necessary.
Dosage check 1 / 2	Controller 1 (or 2, resp.) gives out a 100% output for more than the defined period of time.	Please check the dosing, especially the feeding tubes and connections. Caution! Carefully check for leaking chemicals!
Ext. controller stop	The digital input has been short-circuited (in the „contact“ mode).	This only indicates the external controller stop. If, however, you have connected a level sensor, this message appears due to the „lack of water“ alarm.
No water	The digital input has been short-circuited (in the „flow“ mode).	The flow has dropped below minimum. Check the flow at the outlet of the armature. If the flow is low although the water supply is ok, take out the filter and clean it with pressurized water. If the flow is still low, also clean the flow sensor.

7. Output

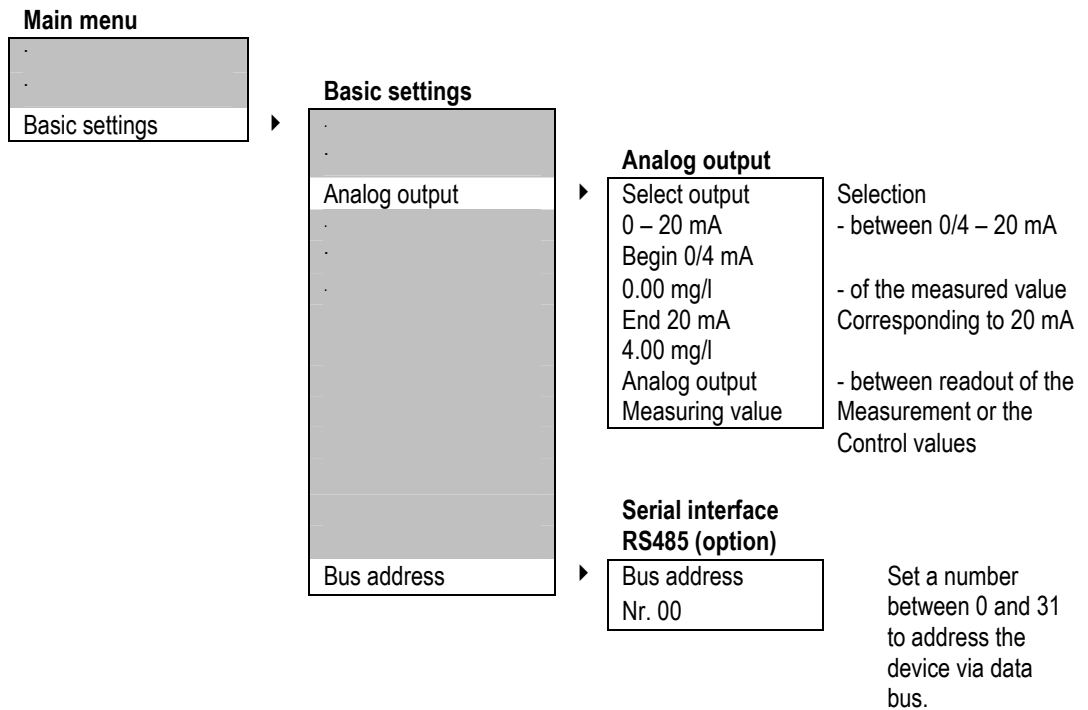

7.1 Current output

You can read out the measured values and the temperature as 0/4...20 mA signals via the current outputs.

With the setting 4...20 mA the resolution is lower, but defective cable connections are immediately evident. With the parameters Begin and End you define which part of the measuring range you want to read out.

Alternatively you can use the current output as steady-state controller output. In that case assign the current output to controller S1 or S2, respectively.

7.2 Serial interface RS485 (option)

The devices are available with serial interface RS485 by means of which they can be integrated in a data bus system. Via the interface, all settings, measured and control values as well as any error messages can be read out digitally.

Devices with RS485 are automatically delivered with the leaflet „Information on the RS485“ which contains instructions on the communication and a complete list of the functions available via interface.

8. Operation and maintenance

8.1 Maintenance of the device

The device does not require any maintenance. There is no need for readjustment. If you want to have the device checked regularly, you are welcome to send it to KROHNE Water Solutions. Alternatively the device can be checked on site by one of our engineers.

8.2 Display contrast

With devices in wall-mounting enclosures the display contrast can be adjusted to the actual light conditions by means of a potentiometer. It is indicated in the connection diagram with the word „display“.

8.3 Exchange fuse

Devices in wall-mounting enclosures have an internal fuse which has to be replaced at need. You will find a spare fuse fixed to the inside of the terminal cover. Information on the fuse can be found in the chapter „Technical data“.

To exchange the fuse, open the front carefully. The fuse is located on the right hand side. It is kept in place by a Bayonet lock. Turn the lock to the left until the fuse pops up. Exchange it and fix the new fuse by turning the lock to the right. Put the front back on and fix it tightly.

Disconnect the power supply before opening the device!



WARNING



ATTENTION

Mind that the cable connections to the front are not damaged, broken or torn during the process!

8.4 Cleaning

The front and the display should not get in touch with organic solutions such as methanol. Never let water get inside the device. We suggest to simply use a damp cloth for cleaning.

8.5 Maintenance of the potentiostatic measurement

The metal surfaces of the electrodes must be cleaned regularly. Membrane sensors need a refill of electrolyte regularly and an exchange of the membrane at needs. For all types of sensors the slope must be determined regularly by calibration.

NOTE

The instrument checks the sensor's response characteristic after each calibration and displays an error message if the sensor has to be cleaned or replaced. See chapter „Error messages“.

8.6 Disposal

For disposal please notice that the device contains electrolyte capacitors which have to be disposed separately.

8.7 Service

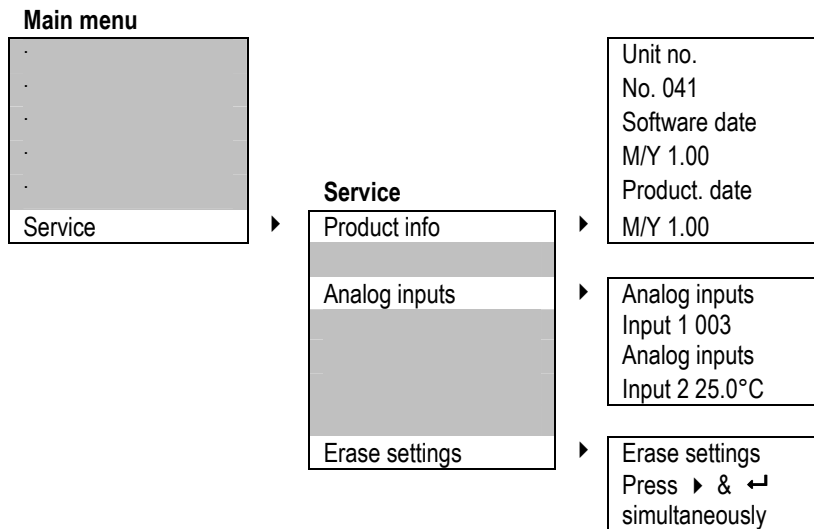

In this menu you will find information which is especially important for any inquiries, updates or problems.

8.7.1 Product info

These figures allow a precise identification of the device (hardware and software).

8.7.2 Analog inputs

Here you can see the raw data the device obtains from the sensors. They are not influenced by compensations or calibration and offer valuable information in case of problems with the measurement or the device.

If you have problems interpreting this data, send them to your supplier together with the device data and ask for support.

8.7.3 Erase settings (reset)

With this function you can erase all customer settings and restore the original at-works data.

The process takes some 30 seconds. When it is finished the display will show the measured value, and the controller will switch off.

9. Technical data

9.1 Technical data

Feature	AC 050 P	AC 050 W
Version	panel-type converter	wall-mounting enclosure
Dimensions (w x h x d)	96 x 96 x 127 mm / 3.8 x 3.8 x 5"	165 x 160 x 80 mm / 6.5 x 6.3 x 3.1"
Weight	0.8 kg / 1.8 lbs	1.0 kg / 2.2 lbs
Terminals	screw terminals max. 1.5 mm ²	
Protection class	IP 54 (front), IP 30 (housing)	IP 65
Power supply	85...265 V AC (48...63 Hz) / DC; option: 18...50 V AC (48...63 Hz) / DC	
Internal fuse	none	230 V: 63 mA slow 110 V: 125 mA slow 24 V: 800 mA semi-slow
Power consumption	10 VA	10 VA
Display	LCD, 2-line, 2x16 characters, illuminated background , measured value and temperature with dimensions indication of relay status	
Current outputs	2 x 0/4...20 mA, galvanically isolated, max. loading 500 Ohm	
Interface (option)	RS485, Baud rate 9600, data format 8Bit, 1 Start and 1 Stop bit	
Controller	ON/OFF controller with hysteresis, P or PI controller as Pulse- Pause- or Impulse-frequency controller, steady controller, bidirectional PI control action, adjustable onset-delay, dosage control function, manual operation of the relays, controller stop via external switch or level sensor (lack-of- water sensor)	
Set points	2 set points adjustable within the measuring range	
Alarm function	with min. and max. limit and turn-on delay	
Contact rating	6 A/ 250 V, max. 550 VA resistive load (with RC protective circuit)	
Operation temperature	0...+50°C / 32...+120°F	
Storage temperature	-20...+65°C / -5...+150°F	
Humidity	max. 90% at 40°C /105°F non-condensing	

9.2 Dimensions

9.2.1 Panel-mounting enclosure

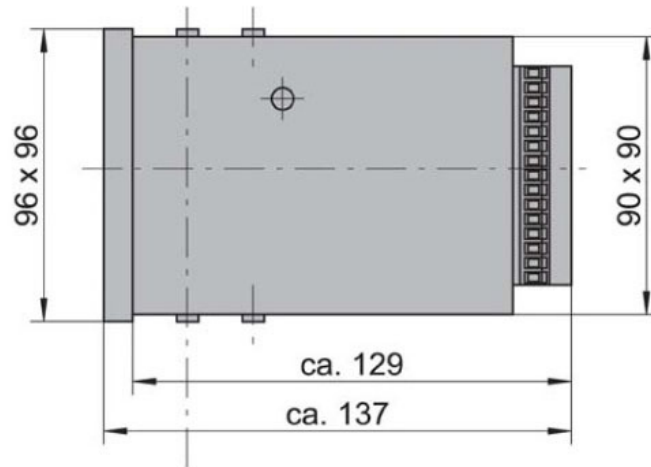

9.2.2 Wall-mounting enclosure

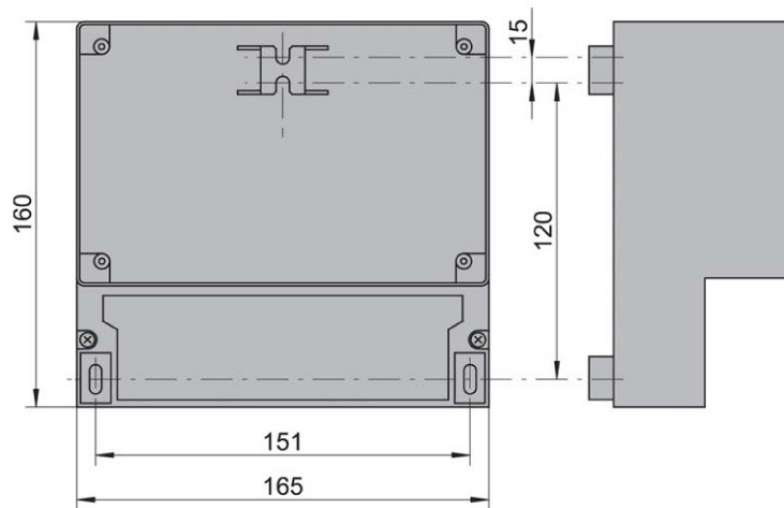

10. Device return form

This device has been carefully manufactured and tested. If installed and operated in accordance with these operating instructions, it will rarely present any problems. Should you nevertheless need to return a device for inspection or repair, please pay strict attention to the following points:

Due to statutory regulations on environmental protection and safeguarding the health and safety of our personnel, KROHNE Water Solutions may only handle, test and repair returned devices that have been in contact with products without risk to personnel and environment.

This means that KROHNE Water Solutions can only service this device if it is accompanied by the following certificate confirming that the device is safe to handle.

If the device has been operated with toxic, caustic, flammable or water-endangering products, you are kindly requested:

- to check and ensure, if necessary by rinsing or neutralizing, that all cavities are free from such dangerous substances,
- to enclose a certificate with the device confirming that is safe to handle and stating the product used.

We cannot service this device unless accompanied by such a form.

SPECIMEN certificate

Company:..... Address:.....

Department:..... Name:.....

Tel. No.:..... Fax No.:.....

Email:.....

The enclosed device

Type:.....

KROHNE Water Solutions Order No. or Series No.:.....

has been operated with the following liquid:.....

Because this liquid is
 water-hazardous toxic caustic.. flammable

we have
 checked that all cavities in the device are free from such substances
 flushed out and neutralized all cavities in the device

We confirm that there is no risk to humans or environment through any residual liquid contained in this device.

11. Customer settings - for reference

Device Identification / location:
 Type: date of installation:
 Serial number: Software version:

Measurement

Chlorine (Cl₂) 4mg/l Chlorine (Cl₂) 20mg/l Total Chlorine (TCI) Chlorine dioxide (ClO₂)
 Oxygen (O₂) 20mg/l O₂ 10mg/l Ozone (O₃) Peroxide (H₂O₂)

Temperature compensation

Manual Temperature: °C Automatic Correction: °C
 Pt100 NTC

Analog outputs

Output 1 Output 2
 0...20mA 4...20mA 0...20mA 4...20mA
 for conductivity for Temperature
 Controller S1 Controller S2 Controller S1 Controller S2
 Start: Start:
 End: End:

Controller

Controller S1 Controller S2
 Acting direction Acting direction
 raise lower raise lower
 Set point: Set point:
 Hysteresis: Hysteresis:
 P range: P range:
 Integral time:s Integral time:s
 Pulse+ pause time:s Pulse+ pause time:s
 Minimum pulse:s Minimum pulse:s
 Pulse frequency:*100/h Pulse frequency:*100/h
 Turn-on delaymin. Turn-on delaymin.
 Dosage checkmin. Dosage checkmin.

Alarm

Limit S1 Limit S2
 Delay time:min.
 normally closed normally open pulse contact perm. contact

Digital input

Contact Flow measurement

Serial interface RS 485

Bus address: