



OPTISENS OAM 2080 Handbook

Sludge blanket measuring system

The documentation is only complete when used in combination with the relevant documentation for the converter.

All rights reserved. It is prohibited to reproduce this documentation, or any part thereof, without the prior written authorisation of KROHNE Messtechnik GmbH.

Subject to change without notice.

Copyright 2010 by
KROHNE Messtechnik GmbH - Ludwig-Krohne-Str. 5 - 47058 Duisburg (Germany)

1	Safety instructions	5
1.1	Software history	5
1.2	Intended use	5
1.3	Certifications	5
1.4	Safety instructions from the manufacturer	6
1.4.1	Copyright and data protection	6
1.4.2	Disclaimer	6
1.4.3	Product liability and warranty	7
1.4.4	Information concerning the documentation	7
1.4.5	Warnings and symbols used	8
1.5	Safety instructions for the operator	8
2	Device description	9
2.1	Scope of delivery	9
2.2	Description of the single components	10
2.3	Nameplate	12
3	Installation	13
3.1	Notes on installation	13
3.2	Storage and transport	13
3.3	Typical measuring point	13
3.4	Installation order	14
3.4.1	Mounting, adjusting and fixing of meter and frame	15
3.4.2	Installation of flushing	17
4	Electrical connections	19
4.1	Safety instructions	19
4.2	Cable connections	19
4.3	Connection diagram and grounding	20
4.4	Rake guard limit switch	20
4.5	Protection category	21
4.6	Power supply	21
5	Operation	22
5.1	Start-up and general remarks for configuration	22
5.2	LED indication	22
5.3	Input of the basic settings	23
5.3.1	Connection of the sensor to a slot and output	23
5.3.2	Definition of positions and zones	24
5.4	Scaling of a 4...20 mA output	26
5.5	Calibration	26
5.6	Manual hauling	27
5.7	Display of sludge profile (optional)	28

5.8	Timer interval (optional).....	29
5.9	Faults: reasons and remedies	30
5.10	Menu for OAM 2000 sensor	31
6	Service	34
<hr/>		
6.1	Manual initiation of a measurement	34
6.2	Maintenance	34
6.3	Spare parts and accessories.....	35
6.4	Spare parts availability.....	36
6.5	Availability of services	36
6.6	Returning the device to the manufacturer.....	36
6.6.1	General information.....	36
6.6.2	Form (for copying) to accompany a returned device.....	37
6.7	Disposal	37
7	Technical data	38
<hr/>		
7.1	Measuring principle.....	38
7.2	Technical data.....	39
7.3	Dimensions	41
8	Notes	42
<hr/>		

1.1 Software history



INFORMATION!

This documentation details the installation and operation of the OPTISENS OAM 2080 sludge blanket meter. For all information related to the converter (e.g. installation or technical data) refer to the converter documentation.

Release date	Software version	Documentation
04/2010	0.7	MA OAM 2080 R01 en

1.2 Intended use



INFORMATION!

The OPTISENS OAM 2080 only works in conjunction with the OPTISENS MAC 080 multiparameter converter which you need for configuration, local display and transmission of the measuring results. Additionally the converter must have the software version 3.1 or higher. The converter and the mounting plate belong to the standard scope of delivery.

In combination with the MAC 080 converter the OAM 2080 sludge blanket meter is primarily designed for use in water and waste water treatment plants. There it determines the sludge blanket depth in clarifiers and sludge thickeners. It measures the suspended solids concentration and height of the sensor above ground as the sensor is lowered into the basin or tank.

However, the design of the OAM 2080 makes it possible to use it in other applications where reliable monitoring of interface or stratification in suspensions is necessary.

1.3 Certifications

CE marking



The device fulfils the statutory requirements of the following EC directives:

- Electromagnetic compatibility (EMC) in accordance with:
EN 61000-6-4:2001: Emission standard for industrial environments;
EN 61000-6-2:2001: Immunity for industrial environments
- Low Voltage Directive:
Safety requirements for electrical equipment for measurement, control and laboratory use in accordance with EN 61010-1:2001

The manufacturer certifies successful testing of the product by applying the CE marking.

1.4 Safety instructions from the manufacturer

1.4.1 Copyright and data protection

The contents of this document have been created with great care. Nevertheless, we provide no guarantee that the contents are correct, complete or up-to-date.

The contents and works in this document are subject to copyright. Contributions from third parties are identified as such. Reproduction, processing, dissemination and any type of use beyond what is permitted under copyright requires written authorisation from the respective author and/or the manufacturer.

The manufacturer tries always to observe the copyrights of others, and to draw on works created in-house or works in the public domain.

The collection of personal data (such as names, street addresses or e-mail addresses) in the manufacturer's documents is always on a voluntary basis whenever possible. Whenever feasible, it is always possible to make use of the offerings and services without providing any personal data.

We draw your attention to the fact that data transmission over the Internet (e.g. when communicating by e-mail) may involve gaps in security. It is not possible to protect such data completely against access by third parties.

We hereby expressly prohibit the use of the contact data published as part of our duty to publish an imprint for the purpose of sending us any advertising or informational materials that we have not expressly requested.

1.4.2 Disclaimer

The manufacturer will not be liable for any damage of any kind by using its product, including, but not limited to direct, indirect, incidental, punitive and consequential damages.

This disclaimer does not apply in case the manufacturer has acted on purpose or with gross negligence. In the event any applicable law does not allow such limitations on implied warranties or the exclusion of limitation of certain damages, you may, if such law applies to you, not be subject to some or all of the above disclaimer, exclusions or limitations.

Any product purchased from the manufacturer is warranted in accordance with the relevant product documentation and our Terms and Conditions of Sale.

The manufacturer reserves the right to alter the content of its documents, including this disclaimer in any way, at any time, for any reason, without prior notification, and will not be liable in any way for possible consequences of such changes.

1.4.3 Product liability and warranty

The operator shall bear responsibility for the suitability of the device for the specific purpose. The manufacturer accepts no liability for the consequences of misuse by the operator. Improper installation and operation of the devices (systems) will cause the warranty to be void. The respective "Standard Terms and Conditions" which form the basis for the sales contract shall also apply.

1.4.4 Information concerning the documentation

To prevent any injury to the user or damage to the device it is essential that you read the information in this document and observe applicable national standards, safety requirements and accident prevention regulations.

If this document is not in your native language and if you have any problems understanding the text, we advise you to contact your local office for assistance. The manufacturer can not accept responsibility for any damage or injury caused by misunderstanding of the information in this document.

This document is provided to help you establish operating conditions, which will permit safe and efficient use of this device. Special considerations and precautions are also described in the document, which appear in the form of underneath icons.

1.4.5 Warnings and symbols used

Safety warnings are indicated by the following symbols.



DANGER!

This information refers to the immediate danger when working with electricity.



DANGER!

This warning refers to the immediate danger of burns caused by heat or hot surfaces.



DANGER!

This warning refers to the immediate danger when using this device in a hazardous atmosphere.



DANGER!

These warnings must be observed without fail. Even partial disregard of this warning can lead to serious health problems and even death. There is also the risk of seriously damaging the device or parts of the operator's plant.



WARNING!

Disregarding this safety warning, even if only in part, poses the risk of serious health problems. There is also the risk of damaging the device or parts of the operator's plant.



CAUTION!

Disregarding these instructions can result in damage to the device or to parts of the operator's plant.



INFORMATION!

These instructions contain important information for the handling of the device.



LEGAL NOTICE!

This note contains information on statutory directives and standards.



• **HANDLING**

This symbol designates all instructions for actions to be carried out by the operator in the specified sequence.

➡ **RESULT**

This symbol refers to all important consequences of the previous actions.

1.5 Safety instructions for the operator



WARNING!

*In general, devices from the manufacturer may only be installed, commissioned, operated and maintained by properly trained and authorized personnel.
This document is provided to help you establish operating conditions, which will permit safe and efficient use of this device.*

2.1 Scope of delivery



INFORMATION!

Inspect the cartons carefully for damage or signs of rough handling. Report damage to the carrier and to the local office of the manufacturer.



INFORMATION!

Check the packing list to check if you received completely all that you ordered.



INFORMATION!

Look at the device nameplate to ensure that the device is delivered according to your order. Check for the correct supply voltage printed on the nameplate.

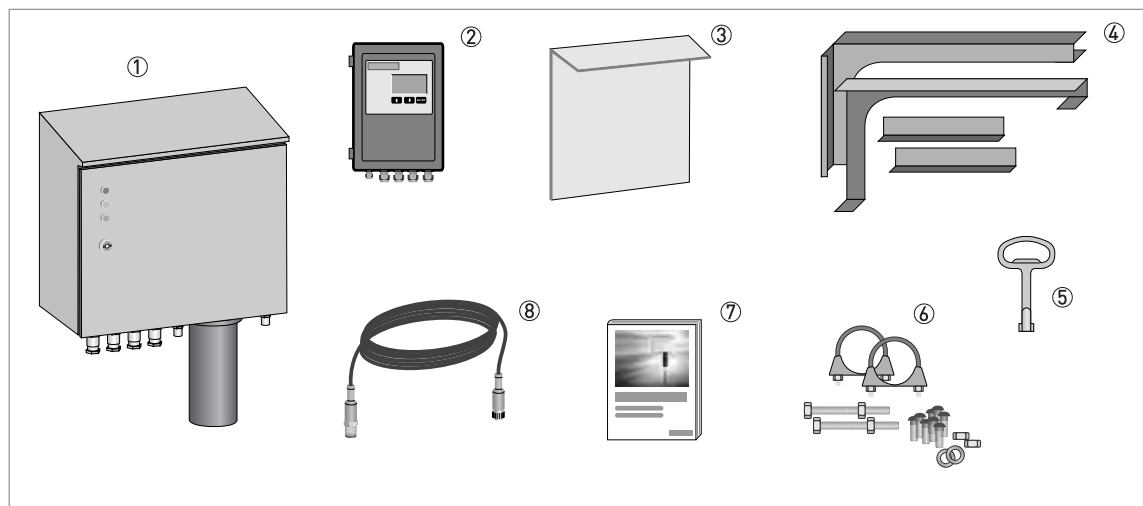

- ① OAM 2080 sludge blanket meter
- ② Converter
- ③ Mounting plate for converter
- ④ Handrail mounting frame
- ⑤ Key for cabinet lock
- ⑥ Mounting accessories
- ⑦ Documentation
- ⑧ Signal cable (1.5 m / 4.9 ft)

For information about optional accessories refer to *Spare parts and accessories* on page 35.

2.2 Description of the single components

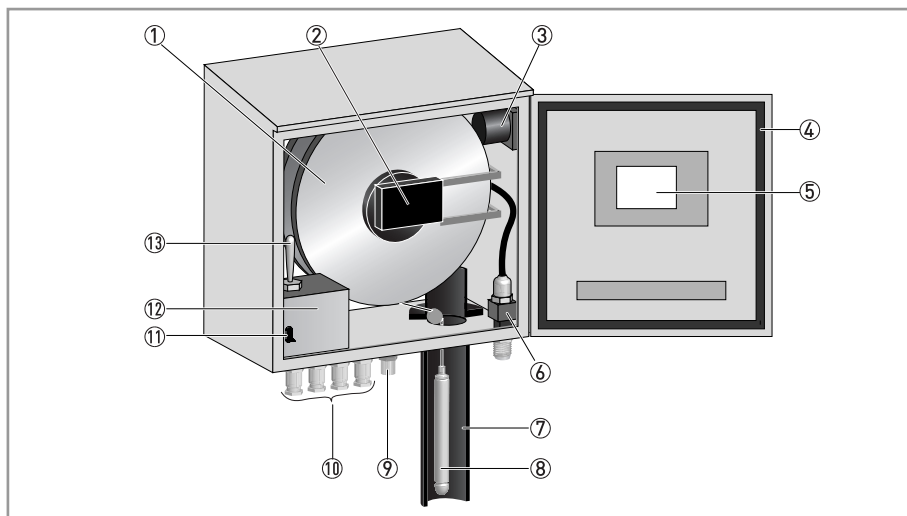

- ① Cable drum assembly
- ② Pickup board and axle board
- ③ Heater and fan
- ④ Gasket
- ⑤ Main electronics unit
- ⑥ Flush valve with flush hose connector
- ⑦ Flushing tube
- ⑧ Sensor
- ⑨ 5-pos. M12 female connector (A-coded)
- ⑩ 1/2" NPT female connector
- ⑪ Safety switch
- ⑫ Junction box with terminal blocks inside
- ⑬ Manual hauling switch
- ⑭ Cable connection terminal

Cable drum assembly

The cable drum helps to move the sensor up and down in the basin. It is mounted directly on the axle of a synchronous motor, hidden behind the drum mounting plate.

The cable drum always moves with a very constant speed. Since the diameter of the cable roll in the drum varies, the speed of the sensor varies. That is why the sensor moves slower during the end of the sampling.

The cable and sensor are cleaned by a water spray in the flushing tube during return to the home position.

Main electronics unit

The main electronics unit is located at the front door in a separate enclosure. It controls all mechanical events in the device and communicates with both the sensor and the converter. The communication with the converter is done through a RS-485 interface.

Other signals going in and out of sludge blanket meter are also conducted to the main electronics unit. The unit collects the values of the sludge concentration from the sensor and transmits them to the converter.

Sensor

The sensor is connected to a cable that supplies the sensor with power. The cable also transmits the communication signals to the pickup board.

The sensor contains a near-infrared light source and a receiver. Both are positioned in such a way that the emitted near-infrared light has to pass through the liquid before reaching the receiver.

Cable connection terminal

The separate box in the lower left corner of the enclosure contains the connection terminal for the external wire connections. To the left of this terminal block there is a safety switch that will disconnect the power when the enclosure door opens.

On the top of the terminal box there is an emergency motor control switch with the functions "Up" and "Down". It allows to control the sensor movement even if the normal control function does not work.

Pickup board & axle board

The pickup board is mounted on a spring loaded lever arm and transfers power and communication signals to the cable drum. It also measures the revolutions of the cable drum with the help of sensors.

The axle board on the cable drum is powered contactlessly ("inductively") from the pickup board. It communicates with the main electronics unit via the pickup board and with the sensor via an optical RS-485 interface.

Heater & fan

The heater is located behind the drum mounting plate. Together with the fan it maintains a stable temperature inside the enclosure of the meter. The position of the fan is on the top right side of the enclosure.

Flush tube and flush valve

The flush tube contains a nozzle ring that sprays cleaning water around the sensor and cable. Each time the sensor moves upwards into the flush tube, the cleaning works until the sensor reaches its highest position ("home position"). In that way the sensor keeps clean and the measurement is reliable in most environments and processes.

In the home position the sensor is completely covered by the flush tube, which contains an inductive limit switch. The switch determines the point when the sensor reaches its home position.

Flushing starts when the built-in solenoid flush valve opens. Its control is the task of the main electronics unit.

2.3 Nameplate



INFORMATION!

Look at the device nameplate to ensure that the device is delivered according to your order. Check for the correct supply voltage printed on the nameplate.

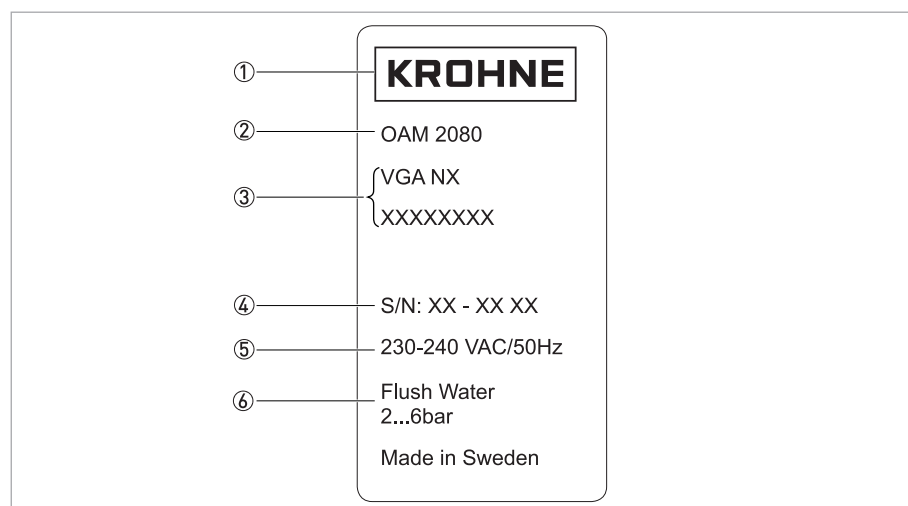

- ① Manufacturer
- ② Device type
- ③ Order code
- ④ Serial number
- ⑤ Voltage information
- ⑥ Pressure specification for flushing

3.1 Notes on installation



INFORMATION!

Inspect the cartons carefully for damage or signs of rough handling. Report damage to the carrier and to the local office of the manufacturer.



INFORMATION!

Check the packing list to check if you received completely all that you ordered.



INFORMATION!

Look at the device nameplate to ensure that the device is delivered according to your order. Check for the correct supply voltage printed on the nameplate.

3.2 Storage and transport

- Store and transport the device in a dry, dust-free environment.
- Store and transport the device in an environment with a temperature between $-20\dots+60^{\circ}\text{C}$ / $-4\dots+140^{\circ}\text{F}$.
- The original packing is designed to protect the equipment. It has to be used if the device is transported or sent back to the manufacturer.

3.3 Typical measuring point

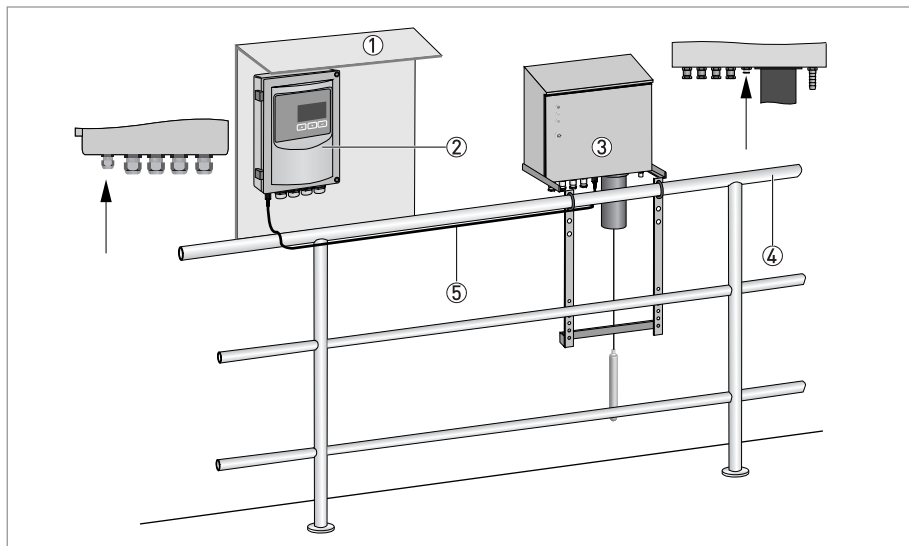

- ① Mounting plate with sun roof
- ② Converter
- ③ Sludge blanket meter
- ④ Handrail
- ⑤ Signal cable

**INFORMATION!**

The OAM 2080 only works in conjunction with the MAC 080 multiparameter converter which you need for configuration, local display and transmission of the measuring results. Additionally the converter must have the software version 3.1 or higher. The converter and the mounting plate belong to the standard scope of delivery.

3.4 Installation order

**DANGER!**

Do not install the sludge blanket meter in hazardous areas, it can ignite explosive gases!

**INFORMATION!**

To install the measuring system in the best way, follow the steps described below. Regard that different steps may vary in meaning, depending on the particular sensor and the number of sensors that you want to connect to the converter.

**INFORMATION!**

All MAC 080 converters with a program version of 3.1 or higher are able to detect and install the sensor automatically. This procedure starts when both the converter and the sensor are supplied with power and the electrical connection between the devices is established.

Steps to install the measuring system

- Mounting of converter
(for detailed information refer to the relevant chapter in the converter manual).
- Mounting of sludge blanket meter
(for detailed information refer to the relevant section in this chapter).
- Installation of flushing, if required
(for detailed information refer to the relevant section in this chapter).
- Connection of the rake guard switch, if required
(for detailed information refer to the relevant section in this chapter).
- Electrical installation of converter
(for detailed information refer to the relevant chapter in the converter manual)
- Electrical installation of the sludge blanket meter
(for detailed information refer to the relevant section in this chapter).
- Setup of converter
(for detailed information refer to the relevant chapter in the converter manual).
- Settings and calibration of the sludge blanket meter
(for detailed information refer to the relevant chapter in the manual of the meter).

3.4.1 Mounting, adjusting and fixing of meter and frame

**INFORMATION!**

All needed bolts, nuts and washers belong to the standard scope of delivery. The most common application is to fix the stand on a handrail as shown in the following instructions.

**Step 1: Assembling of stand**

- Assemble the two brackets and two crossbar braces with the help of bolts, nuts and washers according to the following drawing.

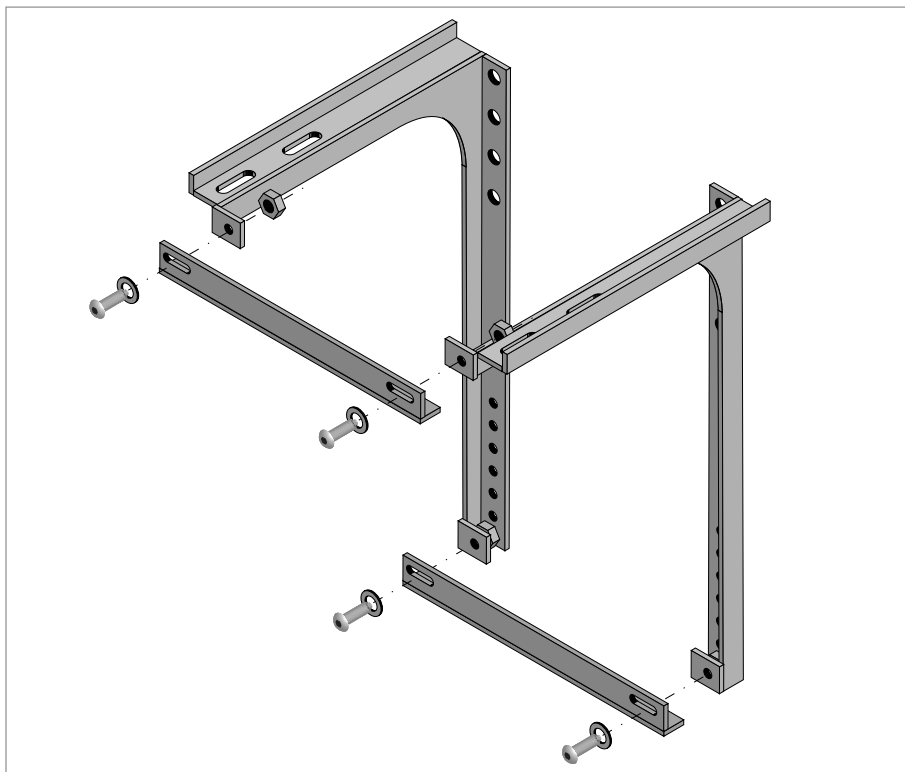

**Step 2: Fixing stand**

- Fix the U-Bolts to the handrail according to the following drawing.
- Fix the frame to the U-Bolts, ask a second person for help.

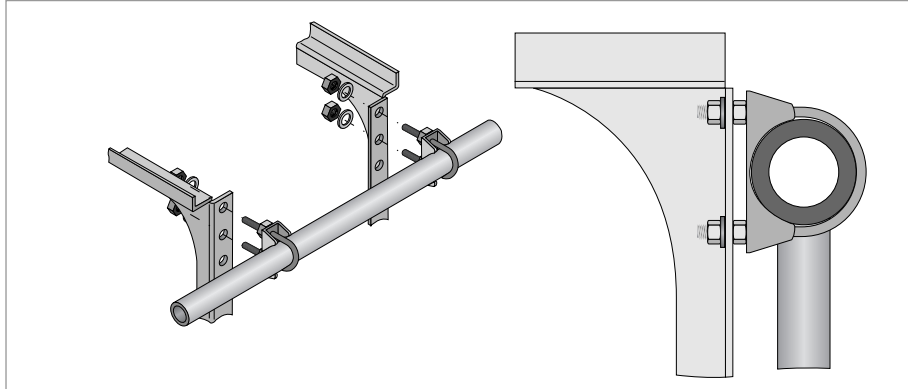
**Step 3: Fixing of meter**

- Fix the meter to the upper part of the brackets with the help of bolts and washers according to the following drawing.

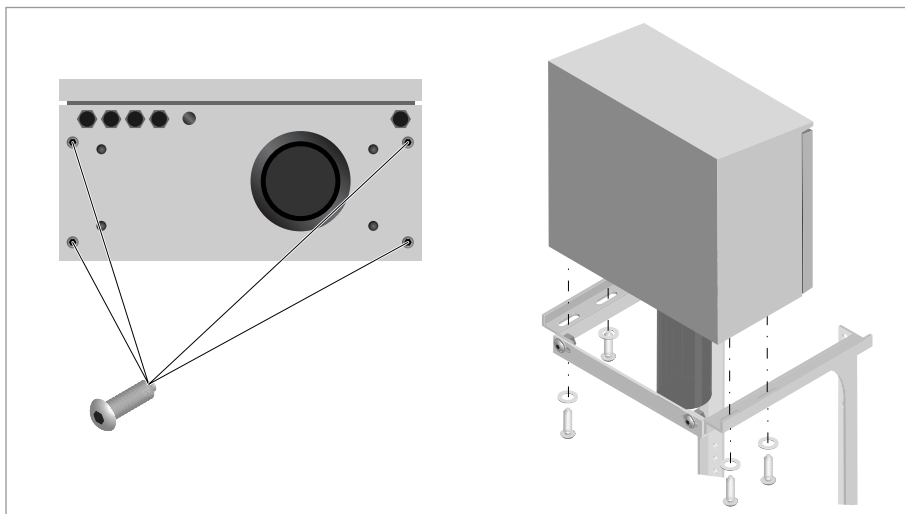



Step 4: Adjusting

- Open the door of the meter for 45°.
- Adjust the meter horizontally using the last two screws that you screw in the lower part of the frame.
- Turn the screws until the door does not move any more in the 45° position.

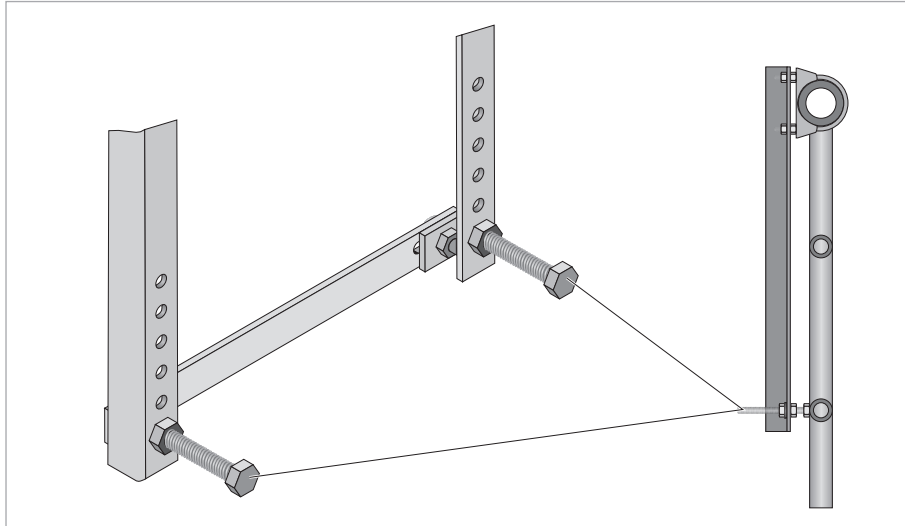

3.4.2 Installation of flushing



CAUTION!

Always regard the following items when installing and using the flushing function:

- *Do not flush the device at temperatures below 0°C / 32°F as there is the risk of damage by freezing water within the flush hoses and the solenoid valve!*
- *Assure that all outdoor installations protect the hoses and the valve from freezing conditions. If this is not possible, disconnect and empty all hoses!*
- *Assure that the flushing water has a pressure between 2 bar / 29 psi and 6 bar / 87 psi. Below the minimum pressure a sufficient cleaning is not possible, a water pressure above the maximum value can cause damages.*
- *Always use filtered water that is free of visible solids as they can cause damages. If this is the case, you can also use town water.*



INFORMATION!

The minimum diameter of the flush hose has to be at least 10 mm / 0.39".

In Europe you can connect the flush hose according to the following drawing. In the USA there are hoses available with a fixed male connector that you can screw-in directly):

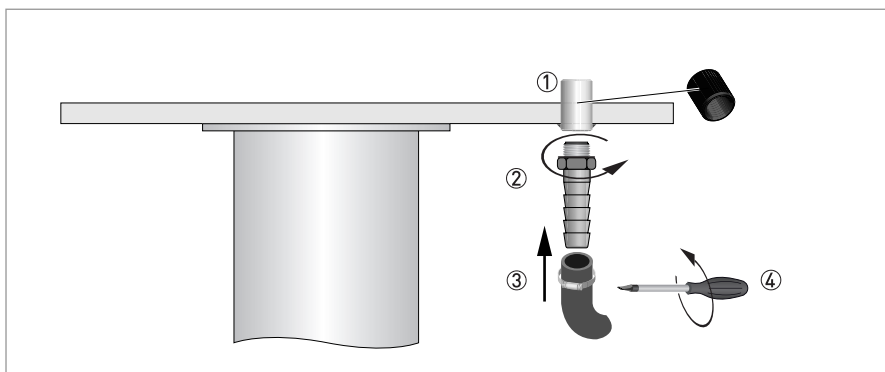

If you do not need the flushing function, you can disable it via the sensor menu. For further information refer to *Menu for OAM 2000 sensor* on page 31.

Plug the flush hose onto the 1/4" NPTmale thread under the lower right hand corner of the enclosure.

4.1 Safety instructions



DANGER!

All work on the electrical connections may only be carried out with the power disconnected. Take note of the voltage data on the nameplate!



DANGER!

Observe the national regulations for electrical installations!



WARNING!

Observe without fail the local occupational health and safety regulations. Any work done on the electrical components of the measuring device may only be carried out by properly trained specialists.



INFORMATION!

Look at the device nameplate to ensure that the device is delivered according to your order. Check for the correct supply voltage printed on the nameplate.

4.2 Cable connections

In the bottom lower left corner of the enclosure there are four ½" NPT female electrical connections as cable feedthroughs to the junction box. All cables fixed on the terminal blocks go outside the enclosure via these connections.

Right beside the ½" NPT female electrical connections there is 5-pos. M12 female connector (A-coded). This connector is wired internally and dedicated for a tailored cable with the corresponding male connector that belongs to the scope of delivery.



INFORMATION!

The connection cable with in the scope of delivery has 5-pos. M12 male connectors (A-coded) on both ends. Both male connectors fit to the female connector on the converter as well as to the connector on the bottom of the enclosure.

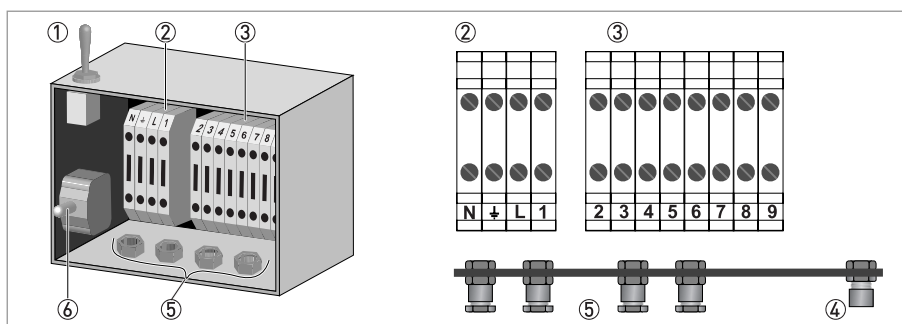

- ① Manual hauling switch
- ② Left terminal block
- ③ Right terminal block
- ④ 5-pos. M12 female connector (A-coded)
- ⑤ ½" NPT female connector
- ⑥ Safety switch

4.3 Connection diagram and grounding

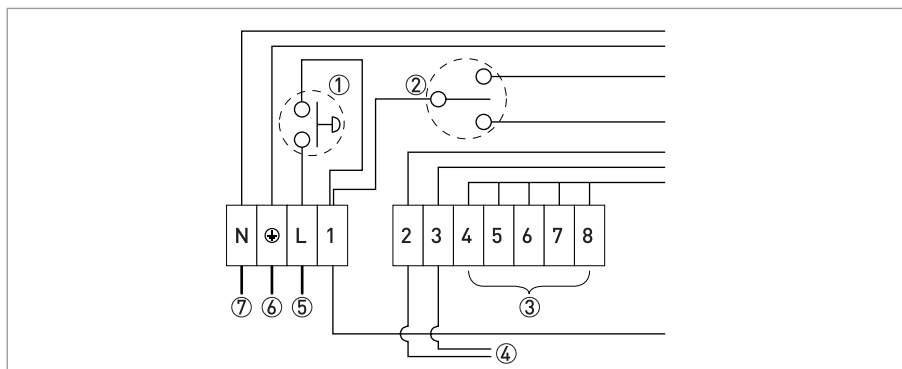

- ① Push-button (door open/closed)
- ② Switch for manual hauling (up/neutral/down)
- ③ Spare I/Os
- ④ I/O for rake limit switch (24 VDC)
- ⑤ Power (live)
- ⑥ Power (earth)
- ⑦ Power (neutral)

4.4 Rake guard limit switch



CAUTION!

To avoid damages or destructions, use a limit switch in all applications where a rake or other moving devices may come in contact with the sensor or cable! The manufacturer does not assume any responsibility for damages caused by the absence or malfunction of the rake guard limit switch.

To protect the sensor and cable from being damaged or destroyed by rakes or other moving parts, the meter has an N/O contact input for the connection of an external limit switch (you have to buy this switch with another manufacturer). The sampling cycle will only start if this switch is closed.

The function of the limit switch is to trigger the sampling process. When the moving device (e.g. a rake) contacts the limit switch, the sampling process starts. You can define the number of passes of the moving device that should occur before starting the sampling process with the help of the converter (see "Trig" in the "Advanced setup" within the menu "Settings"). For information concerning the electrical connection of a rake guard limit refer to the next chapter.



INFORMATION!

Defining the interval of the sampling process is suitable when the position of the moving device is well known (e.g. with surface rakes). If the moving device contacts the limit switch during sampling, the sampling process stops and the sensor moves upwards.

If there is no danger for the sensor or cable to be caught by moving devices (i.e. installation in thickeners without stirrers), you can set an alternative sampling mode in the converter controlled by the build-in timer. In this case you must wire the connections for the rake guard switch to one of the converter relays (for further information see section "Relay outputs" in chapter 4 "Electrical connections" in the MAC 080 handbook) and set a timer interval in seconds, which triggers the sampling cycle accordingly (for further information refer to *Timer interval (optional)* on page 29).

4.5 Protection category



DANGER!

Do not install the sludge blanket meter in hazardous areas, it can ignite explosive gases!

The whole meter fulfills the protection category IP55, while the capsuled electronic fulfills IP 65, NEMA 4.

4.6 Power supply



CAUTION!

As the meter does not have an own switch to deenergize it, the manufacturer recommends that the power supply has an external on-off switch.

The correct power supply of the meter takes place with the help of a 3-lead cable which is approved for the rated current and voltage.

5.1 Start-up and general remarks for configuration



INFORMATION!

- *Connect the converter and the meter before starting-up! The MAC 080 converter must have the program version 3.1 or higher, otherwise it cannot work together with the meter. If the converter has a lower program version, always contact the manufacturer for an update!*
- *You are not able to make any changes to the settings until the converter has recognized the sensor! You have to configurate the meter with the help of the converter and its display and buttons.*

The start-up procedure of the sensor begins when both the converter and the sensor are supplied with power and the electrical connection between the devices is established. First of all the converter performs a self-test, then the identification of the sensor starts. During this process, which may take up to 30 seconds, the converter display shows a rotating line between the header and the time on the first line of the display. Afterwards a wizards appears and you have to connect the sensor to an empty slot. For further information refer to the next section.

5.2 LED indication

There are three LEDs (red, yellow, green) on the front door of the meter which indicate its operation status.

Operation status	Red	Yellow	Green
Starting up.	On	On	On
Standby, waiting for next sampling cycle.	Off	Off	On
Configuration mode.	Off	Off	Blinking
Taking sample.	Off	Blinking	Off
Configuration error (something in the parameter settings stops the device from operating).	Blinking	Blinking	Blinking
Operation error (mechanical or electrical fault that stops the device from operating).	On	Off	Off

5.3 Input of the basic settings

5.3.1 Connection of the sensor to a slot and output

After starting-up and identifying the sensor, the converter needs to know how it shall be used. Therefore a connection wizards with the question if you want to connect the sensor with the first free slot appears on the converter display



Connection to a slot

- Choose "Yes" or "No" with the help of ↑ or ↓ and confirm by pressing ↵.
- ➡ If you chose "Yes", the converter jumps to the choice of the 4...20 mA output. If you chose "No", the converter jumps to the next free slot and asks again if you want to connect the sensor.
- If you chose "No", repeat the previous procedure until you find a suitable free slot.



INFORMATION!

If no slot is free, the converter display shows an error message and demands to free slots. You can free slots with no sensor currently connected in the converter menu; the description for this procedure is in preparation, you will find it in the converter documentation.



INFORMATION!

If you connect an identical sensor, you can reuse the slot of the former sensor if both have the same software revision. To quickly get the new sensor running, it inherits most of the configuration and calibration of the old sensor. This calibration will not be perfect since it has been done for another sensor, but it will be closer than the factory default.

After connecting the sensor with a slot the converter asks which output you want to use. If you added a sensor to slot 1 or 2, the converter asks if the corresponding 4...20 mA output should be used, unless another sensor uses it (you can change the use of an output in the submenu "Analog" of the main menu "Settings", on page 31):



Second step: Choice of 4...20 mA output

- Choose "Yes" or "No" with the help of ↑ or ↓ and confirm by pressing ↵.
- ➡ If you chose "Yes", the connection procedure is complete and the device returns to the normal measuring mode. If you chose "No", the converter jumps to the next output and asks again if you want to use it.
- If you chose "No", repeat the previous procedure until you find a free current output.

5.3.2 Definition of positions and zones

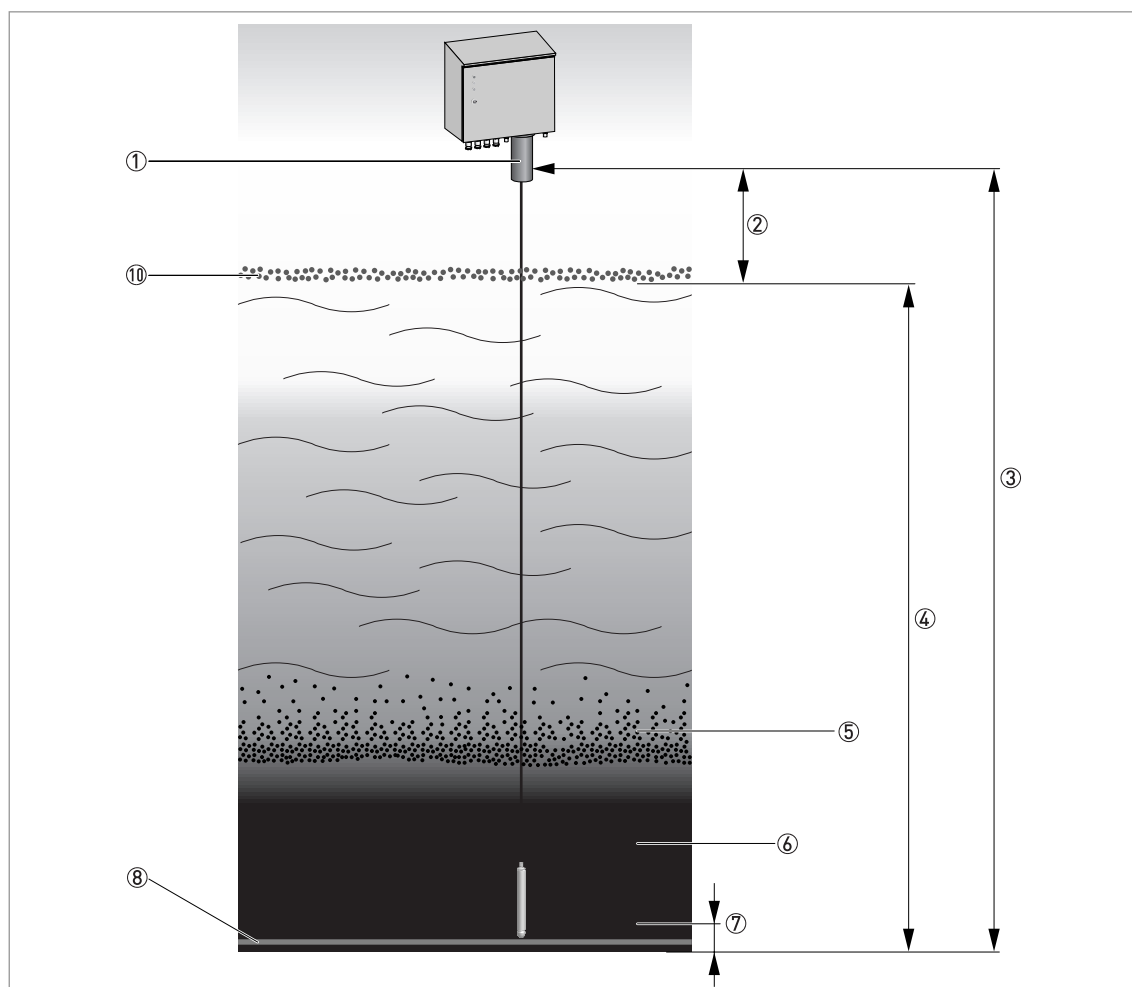

- ① **Home position:** the sensor will always return to this position, which is in the flushing tube.
- ② **Blind zone:** if the sensor detects sludge or foam in this zone during lowering, the meter does not register this detection. You can prevent unwanted measurement by setting this zone to be 0.3 m / 1 ft below the normal liquid surface.
- ③ **Maximum immersion depth:** this is the maximum distance from the home position. The sensor will stop at this depth if it detects no sludge. Note: the sensor might stop and return at a shorter distance if a possibly existing limit switch interrupts the sampling process!
- ④ **Measuring zone:** in this zone the sensor delivers measuring results and the output signal varies from 4...20 mA.
- ⑤ **Fluff layer:** defined by the preset sludge concentration.
- ⑥ **Sludge blanket:** defined by the reset sludge concentration.
- ⑦ **Bottom rake zone:** here a possibly existing bottom rake operates. The top of this zone is the height where the sensor always has to stop during lowering to avoid hitting the bottom rake.
- ⑧ **Bottom rake**

For a complete and safe sampling process the meter needs to know some of the distances described above. Execute the following steps before starting the first measurement:



First step: changing the working mode

- Press ↑ and ← simultaneously for 5 seconds to open the sensor menu.
- Use ↓ to select the main menu "Calibrate" and enter it by pressing ←.
- Use ↓ to select the submenu "Mode" and enter it by pressing ←.
- Use ↓ to select the option "Setup" and confirm by pressing ←.
- The cursor jumps back to the submenu "Mode".
- Press ↑ until you reach the top and then press ← to exit the menu "Calibrate".
- You are in the main menu level now.



Second step: finding out the distances

- Use ↓ to select the main menu "Settings" and enter it by pressing ←.
- Use ↓ to select the submenu "Manual" and enter it by pressing ←.
- Now you can move the sensor upwards and downwards with ↑ or ↓, the MAC 080 display shows the distance of the sensor from its home position and the measured consistency.
- Use ↓ to lower the sensor head 0.3 m / 1 ft below the liquid surface.
- Note this distance down, it is the length of the "blind zone" (see drawing above).
- Use ↓ to lower the sensor until it touches the bottom (you can identify this point by watching the cable go slack).
- Use ↑ to pull up the sensor until you have about 5 cm / 2" of clearance between the bottom of the clarifier and the sensor.
- Note the distance down, it is the "maximum depth" (see drawing above).
- Exit the submenu "Manual" by pressing ←.
- The sensor moves upwards to its home position and the cursor jumps to the main menu "Settings".



Third step: entering the distances

- In the main menu "Settings" use ↑ or ↓ to go to the submenu "Advanced setup" and enter it by pressing ←.
- Within the submenu "Advanced setup" select the option "Max depth", enter the value you have found out with the help of ↑ and ↓ and press ← to confirm.
- Use ↓ to go to the option "Blind zone" and repeat the procedure of the previous step.
- Optionally you can go to the option "Rake height" with the help of ↓ and repeat the procedure of the previous step (be aware that you cannot find out the rake height or slope with the help of lowering the sensor, you have to ask for these values).
- Press ↑ until you reach the top and press ← to exit the submenu "Advanced setup".
- You are in the main menu "Settings" again.



Fourth step: entering the consistencies and returning to measuring mode

- In the main menu "Settings" use ↓ to go to the submenu "Blanket Cons" and enter it by pressing ←.
- Enter the consistency that will define the detection of the sludge blanket with the help of ↑ and ↓.
- Press ↑ until you reach the top and exit the submenu "Blanket Cons" by pressing ←.
- If necessary repeat the previous steps with the fluff consistency ("Fluff Cons", next submenu after "Blanket Cons").
- Press ↑ until you reach the top, then press ← to exit the main menu "Settings".
- Go to the main menu "Calibrate" and change the working mode as described in the first step.
- Leave the sensor menu by pressing ↑ and ← for 5 seconds.
- ➡ The meter is in the normal measuring mode now.

5.4 Scaling of a 4...20 mA output

The scaling function allows the user to set the high and low boundaries for a 4...20 mA output signal. In addition, this menu offers the opportunity to set the high and low alarm values to switch a relay when the solid concentration has reached a critical point. For further information refer to *Menu for OAM 2000 sensor* on page 31.

5.5 Calibration

Before leaving the factory the sensor is calibrated to offer an accurate measurement. Though it might be necessary to re-calibrate the sensor during the lifetime of the system.



INFORMATION!

Even after the installation, a re-calibration with sludge might improve the accuracy. Zero calibration is done with clean, de-aerated water in a bucket. Sludge calibration is done with a known sample in a bucket.



Running a calibration

- Press ↑ and ← simultaneously for 5 seconds to open the sensor menu.
- Use ↓ to go to the menu "Calibrate" and enter it by pressing ←.
- Use ↓ to choose the submenu "Mode" and enter it by pressing ←.
- Use ↓ to choose the option "Setup" and press ←.
- ➡ The cursor jumps back to the submenu "Mode", the green LED on the door blinks and will continue blinking while making changes.
- Use ↓ to choose the submenu "Manual" and enter it by pressing ←.
- ➡ Now you can move the sensor upwards and downwards with ↑ or ↓, the MAC 080 display shows the distance of the sensor from its home position and the measured consistency.
- Lower the sensor with the help of ↓ and position it approximately 1 m / 3.3 ft under the flushing tube.
- Put the sensor into a bucket with clean water (zero calibration) or sludge (sludge calibration).
- Leave the submenu "Manual" by pressing ←.
- ➡ The manual hauling function is now disabled again and the cursor is in the main menu "Calibrate".
- Use ↓ to go to the submenu "Take sample" and press ←.
- Use ↓ to choose either "Zero" (zero calibration) or "Sample" (sludge calibration); you can also choose "No" if you want to leave the submenu without calibration.
- Press ← to initiate the measuring process.

- The device measures the consistency of the clean water or the sludge. In case of zero calibration the display shows the message "Zero calibration done" at the end, in case of sludge calibration the display shows the measured value in a new pop-up window.
- In case of a sludge calibration press \leftarrow to store the value and take the sample to a laboratory to determine the sludge content.
- Irrespective of the calibration type press \leftarrow to close all messages and return to the submenu level of the main menu "Calibrate".
- If you want to return to the normal measuring mode, go to the submenu "Mode" again and choose the option "Trig" (procedure is similar to the one on the beginning of this actionsequence).
- The green LED on the door now burns steadily.
- Press \uparrow and \leftarrow for 5 seconds to go to the normal measuring mode.



Entering the laboratory result (sludge calibration)

- Press \uparrow and \leftarrow simultaneously for 5 seconds to open the sensor menu.
- Use \downarrow to go to the menu "Calibrate" and enter it by pressing \leftarrow .
- Use \downarrow to choose the submenu "Sample" and enter it by pressing \leftarrow .
- Enter the laboratory result with the help of \uparrow or \downarrow and confirm by pressing \leftarrow .
- The converter will automatically correct the sludge consistency value from now on.
- Return to the normal measuring mode by pressing \uparrow and \leftarrow for 5 seconds.

5.6 Manual hauling

The meter has a manual hauling function. With the help of the safety switch you can override the main board control of the cable drum motor and make the sensor go up or down with the manual hauling switch (refer to *Description of the single components* on page 10). Forcing the sensor to go up might be necessary for example if the meter stops functioning correctly during an active sample.

For manual hauling execute the following steps and :



- Open the enclosure with the help of the key you find in the scope of delivery.
- Press the safety switch coming out of the front side of the connection terminal box to supply the device with power.
- To make the sensor go up or down use the manual hauling switch on the top of the connection terminal box (the switch has three positions: up/neutral/down).

5.7 Display of sludge profile (optional)



INFORMATION!

This function requires an expansion module with two more 4...20 mA outputs in the MAC 080 converter. Altogether the converter has four outputs with the extra card. For detailed information about the installation of the converter expansion module refer to the section "Description of additional analog outputs" in the converter manual.

When using the profile function, the single channels transmit the following measuring results (refer to on page 24 for information concerning the positions and zones):

Channel	Measuring result
1	Height of sludge blanket, every new measurement updates the signal. The scale is defined by the maximum and minimum value entered in the menu "Scale / Alarm".
2	Height of fluff blanket, every new measurement updates the signal.
3	Consistency, displayed in real-time during a measurement (otherwise 0 mA if no measurement takes place), scale is locked to 0...10000 mg/l.
4	Depth of sensor, displayed in real-time during a measurement (otherwise the output channel remains on 20 mA if no measurement takes place).

Execute the following steps to activate the profile function:



- Press ↑ and ← simultaneously to enter the sensor menu.
- Use ↓ to go to the main menu "Settings" and enter it by pressing ←.
- Use ↓ to go to the submenu "Analog" and enter it by pressing ←.
- Use ↓ to choose "All" and confirm by pressing ←.
- Press ↑ until you reach the top and press ← to exit the submenu "Analog".
- ➡ You are in the main menu "Settings" again.
- Use ↓ to go to the submenu "Second" and enter it by pressing ←.
- Use ↓ to choose "Fluff" and confirm by pressing ←.
- Press ↑ until you reach the top and press ← to exit the submenu "Second".
- ➡ You are in the main menu "Settings" again.
- Use ↓ to go to the submenu "Advanced setup" and enter it by pressing ←.
- Use ↓ to go to the option "Track" and enter it by pressing ←.
- Use ↓ to go to "Profile" and confirm by pressing ←.
- Exit the submenu "Advanced setup" by pressing ↑ and ← for five seconds.
- Leave the sensor menu by pressing ↑ and ← for 5 seconds.
- ➡ The meter is in the normal measuring mode now.

Example of a typical sludge profile

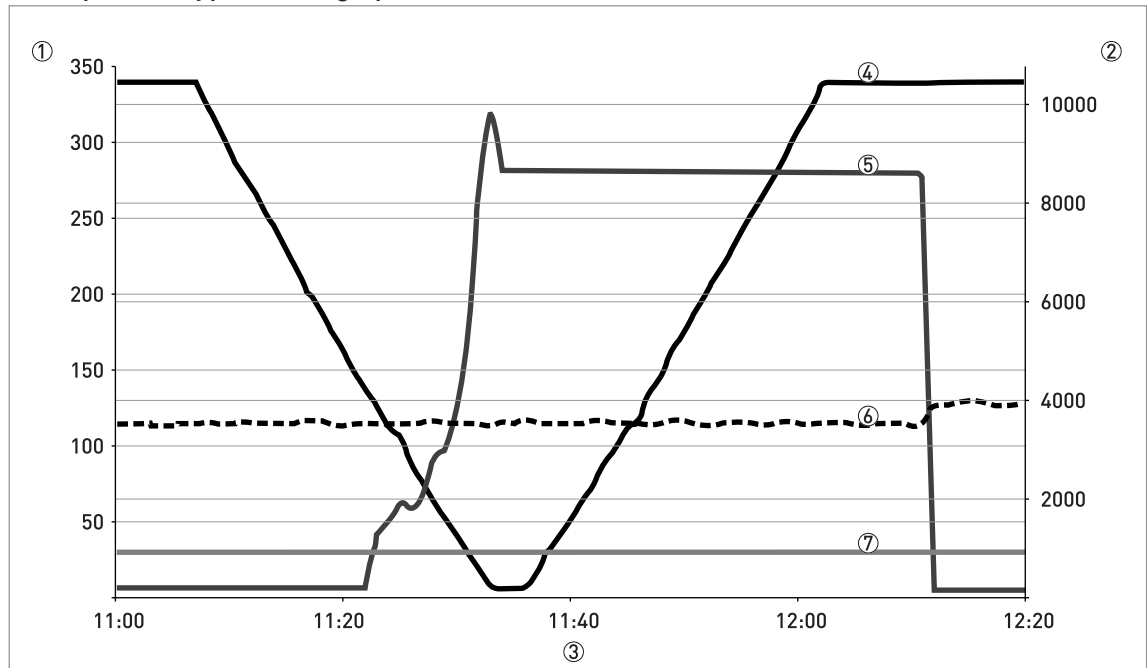

- ① Immersion depth of the sensor in centimetres
- ② Consistency in mg/l
- ③ Time axis
- ④ Level measurement curve
- ⑤ Consistency curve
- ⑥ Sludge layer curve
- ⑦ Fluff layer curve

In the previous drawing the expansion of the sludge blanket is 0.3 m / 1 ft and of the fluff layer it is 0.9 m / 3 ft.

5.8 Timer interval (optional)

To protect the sensor and the cable from damages or destruction by rakes or other moving parts, a rake guard limit switch can control the measuring cycle (on page 20).

If there is no danger for the sensor or cable to be caught by moving devices (i.e. installation in thickeners without stirrers), you can set an alternative sampling mode controlled by the build-in timer. In this case you have execute the following steps to select the trigger relay in the converter and set the time interval in minutes:



- Press ↑ and ← simultaneously for 5 seconds to open the sensor menu.
- Use ↓ to go to the menu "Timer" and enter it by pressing ←.
- Use ↓ to go the submenu "Timer" and enter it by pressing ←.
- Use ↓ to go the option "On" and press ←.
- Use ↓ to go the submenu "Interval min" and enter it by pressing ←.
- Use ↑ and ↓ to set the timer interval in minutes and confirm by pressing ←.
- Use ↓ to go the submenu "Relay" and enter it by pressing ←.
- Use ↑ and ↓ to select the relay to which the rake guard contacts are wired to and confirm by pressing ←.
- Return to the normal measuring mode by pressing ↑ and ← for 5 seconds.

5.9 Faults: reasons and remedies

Complete stop of all operations, no indication on converter display

The reason for this case may be a surge of external power. Irrespective of the reason you can perform a reset by switching the device off and on. For this purpose open the front door and close it again.

Furthermore the device can detect a number of errors. In this case the alarm contact closes and the display shows a message in plain text that indicates the kind of error. Each error may stop the device, you can soft reset it by pressing ← on the converter and if this does not work you can make a hard reset as described above:

Message "SENSOR TILT" on converter display

This message indicates that the sensor has tilted more than 45 degrees and that the tilt switch in the sensor has detected this. In this case the converter not only shows a message, but the sensor also goes up to its home position.

Message "SENSOR ERROR" on converter display

This message indicates that the converter does not receive any signals from the sensor. In this case the converter not only shows a message, but the sensor also goes up to its home position.

Message "SENSOR STOPPED" on converter display

This message indicates that the cable drum is standing still though it should move.

5.10 Menu for OAM 2000 sensor

Use ↑ or ↓ to select the sensor in the main display. The menu for the selected sensor is accessed by pressing ↵ for five seconds. If the selected sensor is not active (the text **No transmitter** is shown) a warning is displayed that asks you to make another choice in order to show the sensor menu.

Menu "Settings"

Submenu	Option	Description
Tag		Name of the sensor shown in the main display (10 characters).
I-Time(s)		Integration time or damping, can be set up to 999 seconds.
Manual		This submenu enables a function in the MAC 080 that allows to move the sensor up or down with the help of the converter buttons ↑ or ↓. In the manual control mode the converter display shows the depth of the sensor and the measured consistency. Note: To use this submenu the device has to work in the operation mode "Trig" (see menu "Calibrate", submenu "Mode")!
Depth Unit		Unit used for distances in OAM 2080 settings. Available options: m, cm, inch, foot.
Cons Units		Unit used for consistency. Available options: "%", "ppm", "g/l", "mg/".
Analog		Sets the analog output channels for sludge blanket depth as primary and second analog for fluff if used. Available options: - (none), all, 1, 2, 3 or 4, available combinations: "1&2" or "3&4".
Second		The second output shows the height of the fluff layer from the bottom. Depending on the chosen channel as primary this can be channel 2 or 4.
Blanket Cons		Sets the consistency that will define the detection of the sludge blanket. This function provides the opportunity to enter the blanket consistency.
Fluff Cons		Sets the consistency that will define the detection of the fluff layer. This function provides the opportunity to enter the fluff consistency.
Advanced setup		Submenu for initial setup of the OAM 2080 with the following options:
	Mains frequ	The frequency of the power (i.e. 50 Hz in Europe and 60 Hz in the USA).
	Trig	Number of trig event before lowering the sensor, you can enter up to 2 digits.
	Max depth	Maximum travel distance from the home position. The sensor will stop at this depth if no blanket or sludge is detected. The travel distance will be shortened if a rake offset is set (refer to on page 24 for information concerning the positions and zones).
	Blind zone	Distance to where the sensor must travel before it starts to measure solids. Sludge or foam detected in this zone during lowering is not registered. Unwanted registration is prevented by setting this zone to reach approximately 25 cm / 0,82 ft below the liquid surface (refer to on page 24 for information concerning the positions and zones).

Submenu	Option	Description
	Rake height	In case of a bottom rake or a slope, this parameter is subtracted from the maximum depth to set the actual stop. At this point the sensor will stop and return home in the case that there is no sludge (refer to on page 24 for information concerning the positions and zones).
	Track	This option determines where the measuring cycle stops. The setting "Level" effects that the measurement stops when the sensor detects the sludge blanket (as defined in the submenu "Blanket Cons"). The setting "Profile" runs each measuring cycle over the complete measuring zone, i.e. the sensor goes to the maximum immersion depth.

Menu "Calibrate"

Submenu	Option	Description
Mode		There are two operation modes:
	Setup	Allows to change the calibration parameters or to use the "MANUAL UP/DOWN" button.
	Trig	Normal working mode, in which the device will take a sample on every external trig.
Manual		For further information see submenu "Manual" in the menu "Settings".
Take sample		Choice of the calibration type.
	No	To abort calibration.
	Zero	To perform a zero point calibration.
	Sample	To perform a sludge calibration.
Cons		Makes the display showing only the current consistency.
Sample		This function provides the opportunity to enter the consistency (i.e. suspended solids value) from a laboratory test.

Menu "Cleaning"

Submenu	Option	Description
Cleaning		
	Yes	Flush cleaning is switched on.
	No	Flush cleaning is switched off.
Manual		For further information see submenu "Manual" in the menu "Settings".

Menu "System"

Submenu	Option	Description
Type		Type of the sensor (read-only information).
Serial		Serial number of the sensor (read-only information).
SoftW		Software version of the sensor (read-only information).
Info		
	Ch1	Raw value of height (no unit).
	Ch2	Raw value of consistency in mV.
	Ch3	Not used
	Ch4	Not used
	Samples	Counter that shows the total number of samples taken by the device on that day.

Menu "Scale / Alarm"

Submenu	Description
Max	Upper end of the measuring zone, equal to an output signal of 20 mA.
Min	Lower end of the measuring zone, equal to an output signal of 4 mA.
Hi-Alarm	Maximum fill level of the basin, here the device produces an alarm.
Low-Alarm	Minimum fill level of the basin, here the device produces an alarm.
Alarm Relay	Alarm relay that should be used on the converter, options: - (none) 1, 2, or 1 & 2. Note: check that the relay is not being used for cleaning!

Menu "Timer"

Submenu	Description
Timer	Allows to switch the timer on or off using one alarm relay to trigger the measuring cycle via a timer.
Interval min	Sets the timer interval in minutes.
Relay	Selects relay to operate solenoid valve for the timer function. Options: - (none) 1 or 2.
Next time	Sets the scheduled time for the next measuring cycle. Pushing \uparrow sets the time to the current time and starts a measuring cycle (this could be used to test the timer).

6.1 Manual initiation of a measurement

For service or maintenance you can manually initiate a measurement:



- Press ↓ on the converter for five seconds.
- ➡ The meter starts with a measurement cycle as soon as possible: the sensor goes down to the defined maximum depth and returns to its home position, afterwards the meter works in the normal mode.
- To stop the sensor during lowering and force it to return to its home position press ↑ on the converter.

6.2 Maintenance

Maintenance schedule

Maintenance action	Once a month	Once every six months	Once a year
Visual check of sensor and clean if necessary.	X	X	X
Visual check of lenses and clean if necessary	-	X	X
Visual check of cable and drum	-	X	X
Cleaning or replacement of air filter	-	-	X
Check of fan	-	-	X
Check of screws and nuts	-	-	X
Sensor check in water	-	-	X

Visual check and cleaning of sensor

Check the sensor for any buildup, i.e. a large amount of dirt. If necessary, clean it with a damp soft cloth.

Visual check and cleaning of lens

Check the lens for any buildup or film. If necessary, clean it with a suitable agent like water or isopropyl alcohol and a soft rag.

Visual check of cable and drum

Check the cable, it must not have any damages or wear and has to be spooled correctly on the drum. Always replace the cable if it shows any damage or severe wear of the insulation!

If the cable is not correctly spooled up or shows a large amount of dirt, lower the sensor manually to the maximum position (refer to *Manual hauling* on page 27) at first. During back hauling monitor the correct guidance of the cable and that it spools up properly, clean it with a soft cloth if necessary.

Cleaning or replacement of air filter

You might need to clean or replace the air filter if the meter works in a dusty environment. For that purpose execute the following steps:



- Remove the cover from the outside.
- Remove the protective grating with a screwdriver and put it back by pressing it by hand.
- Clean the air filter or take a new one if cleaning is not possible.
- Reassemble the devices in reverse order.

Check of fan

Make sure that the fan starts every time when the sensor is on the way up.

Check of screws and nuts

Verify that every screw or nut is properly secured and that no loose parts are rattling.

Sensor check in water

Check the sensor by immersion in water, this should give a low measuring value or even a "0" on the converter display. By placing something solid (e.g. your finger) in the gap between the LED and the sensor you should get a measuring value of 3000...9999 (depending on the calibration).

6.3 Spare parts and accessories



INFORMATION!

All spare parts and accessories do not have any order codes, just contact the manufacturer.

- Signal cable (1.5 m / 4.9 ft)
- Signal cable extensions (10 m / 32.8 ft or 30 m / 98.4 ft)
- Sensor with cable
- Air filter
- Flushing valve (115 V or 230 V)
- Electric motor (115 V or 230 V)
- Fan (115 V or 230 V)

6.4 Spare parts availability

The manufacturer adheres to the basic principle that functionally adequate spare parts for each device or each important accessory part will be kept available for a period of 3 years after delivery of the last production run for the device.

This regulation only applies to spare parts which are under normal operating conditions subjects to wear and tear.

6.5 Availability of services

The manufacturer offers a range of services to support the customer after expiration of the warranty. These include repair, technical support and training.



INFORMATION!

For more precise information, please contact your local representative.

6.6 Returning the device to the manufacturer

6.6.1 General information

This device has been carefully manufactured and tested. If installed and operated in accordance with these operating instructions, it will rarely present any problems.



CAUTION!

Should you nevertheless need to return a device for inspection or repair, please pay strict attention to the following points:

- *Due to statutory regulations on environmental protection and safeguarding the health and safety of our personnel, manufacturer may only handle, test and repair returned devices that have been in contact with products without risk to personnel and environment.*
- *This means that the manufacturer can only service this device if it is accompanied by the following certificate (see next section) confirming that the device is safe to handle.*



CAUTION!

If the device has been operated with toxic, caustic, flammable or water-endangering products, you are kindly requested:

- *to check and ensure, if necessary by rinsing or neutralizing, that all cavities are free from such dangerous substances,*
- *to enclose a certificate with the device confirming that is safe to handle and stating the product used.*

6.6.2 Form (for copying) to accompany a returned device

Company:		Address:	
Department:		Name:	
Tel. no.:		Fax no.:	
Manufacturer's order no. or serial no.:			
The device has been operated with the following medium:			
This medium is:	water-hazardous		
	toxic		
	caustic		
	flammable		
	We checked that all cavities in the device are free from such substances.		
	We have flushed out and neutralized all cavities in the device.		
We hereby confirm that there is no risk to persons or the environment through any residual media contained in the device when it is returned.			
Date:		Signature:	
Stamp:			

6.7 Disposal



CAUTION!

Disposal must be carried out in accordance with legislation applicable in your country.

7.1 Measuring principle

The sensor is let down into the clarifier or thickener and measures the suspended solids concentration. While it descends, it transmits the data via a communication cable to the MAC 080 converter. By submersing the sensor into the liquid, you are able to obtain reliable suspended solids readings and avoid problems from foam and fluff layers in the clarifier or thickener.

The sensor measures transmitted light through the liquid. The measuring principle is based on the suspended particles ability to absorb and reflect NIR (Near Infra-red) light. The light source is a light emitting diode that pulses and emits monochromatic light with a wavelength of 880 nm (see drawing below).

The detected measuring signal is inversely logarithmical proportional to the concentration of suspended solids. Signal treatment or linearization is done within the converter. In addition, the temperature is measured to be used for temperature compensation of the measured value.



INFORMATION!

The built-in temperature measurement is not a precision measurement, but shall be seen as an indication.

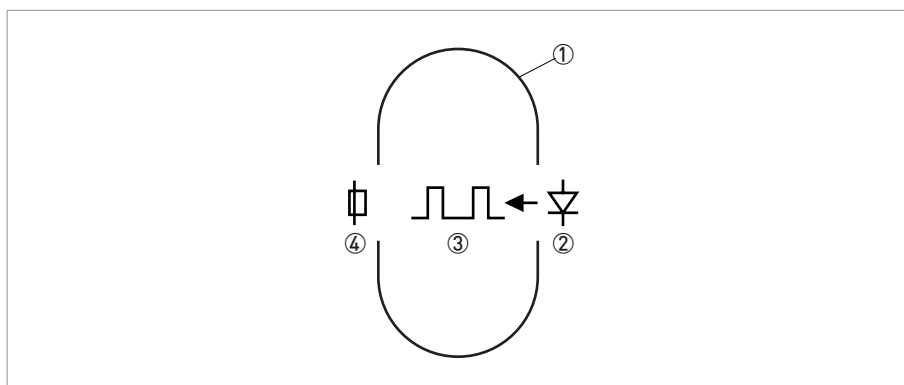

Figure 7-1: Cross-section of measuring gap

- ① Measuring gap
- ② Light source (NIR-LED)
- ③ Monochromatic light beam
- ④ Detector

7.2 Technical data



INFORMATION!

- The following data is provided for general applications. If you require data that is more relevant to your specific application, please contact us or your local representative.
- Additional information (certificates, special tools, software,...) and complete product documentation can be downloaded free of charge from the website (Download Center).

Measuring system

Measuring principle	Reflection and absorption of light on suspended solids and sludge particles. The light passes the measured particles between the emitter and the detector of the optical sensor in a straight line.
Application range	Continuous measurement of the suspended solids concentration in waste water and sludge (e.g. in aeration basins).

Design

Features	<ul style="list-style-type: none"> • Usage of NIR (Near Infra-red) light with 880 nm • Reference measurement • Temperature-compensated
Modular construction	A typical measuring system consists of the MAC 080 multiparameter converter and the OAM 2080 main unit.
Measuring range	0...20000 mg/l, depending on sludge type (Note: the factory calibration was done for the range 0...14000 mg/l).
	Sensor can be let down and is waterproofed up to 10 m / 32,8 ft maximum immersion depth.
Drive	Lowering speed: maximal 15 cm / 5,9" per second, 12,5 cm / 4,9" at 50 Hz
	Full cycle time for 10 m / 32,8 ft: 3 min
Rake guard switch	Closing contact normally open, 24 VDC is supplied from OAM 2080.
Display and user interface	Refer to MAC 080 handbook.
Internal heating	"Off" above 15°C / 59°F, full power below 5°C / 41°F.
Transmission of measuring results	Via 4...20 mA outputs (or optional via Profibus DP) to the converter.

Measuring accuracy

Reference conditions	Medium: water
	Temperature: 20°C / 68°F
	Pressure: ambient
Maximum measuring error (sensor)	5% full scale
Maximum measuring error (immersion depth)	0,5% full scale

Operating conditions

Temperatures and pressure	
Ambient temperature	-20...+50°C / -4...+122°F
Process temperature	0...+50°C / +32...+122°F
Storage temperature	-10...+60°C / +14...+140°F
Maximal immersion depth	10 m / 32,8 ft
Water pressure (process)	Ambient
Water pressure (flushing)	2...6 bar / 29...87 psi
Protection category	IP 55

Installation conditions

Installation position	Fixing on a handrail at open channels, basins or tanks.
Dimensions & weights	For detailed information refer to the section "Dimensions and weights".

Materials

Enclosures	Whole meter and sensor: SIS 2343 (316 SS)
Connection cable to converter	Polyurethane

Electrical connections

Power supply (voltage)	Europe: 230...250 VAC at 50 Hz
	USA: 115 VAC at 60 Hz
Power consumption	Maximal 450 W
Fuse	5 A (T1AH, 20 x 5 mm)
Connection cable to converter	5-pin M12 contact, shielded, 1,5 m / 4,9 ft long (extension cables optionally available).
Input and output (converter)	Refer to technical documentation of the relevant converter.

Approvals and certifications

CE	The device fulfils the statutory requirements of the EC directives. The manufacturer certifies that these requirements have been met by applying the CE marking.
EMC	Electromagnetic compatibility (EMC) in accordance with: <ul style="list-style-type: none"> • EN 61000-6-4:2001 (Emission standard for industrial environments) • EN 61000-6-2:2001 (Immunity for industrial environments)
Low Voltage Directive	Safety requirements for electrical equipment for measurement, control and laboratory use in accordance with EN 61010-1:2001.

7.3 Dimensions

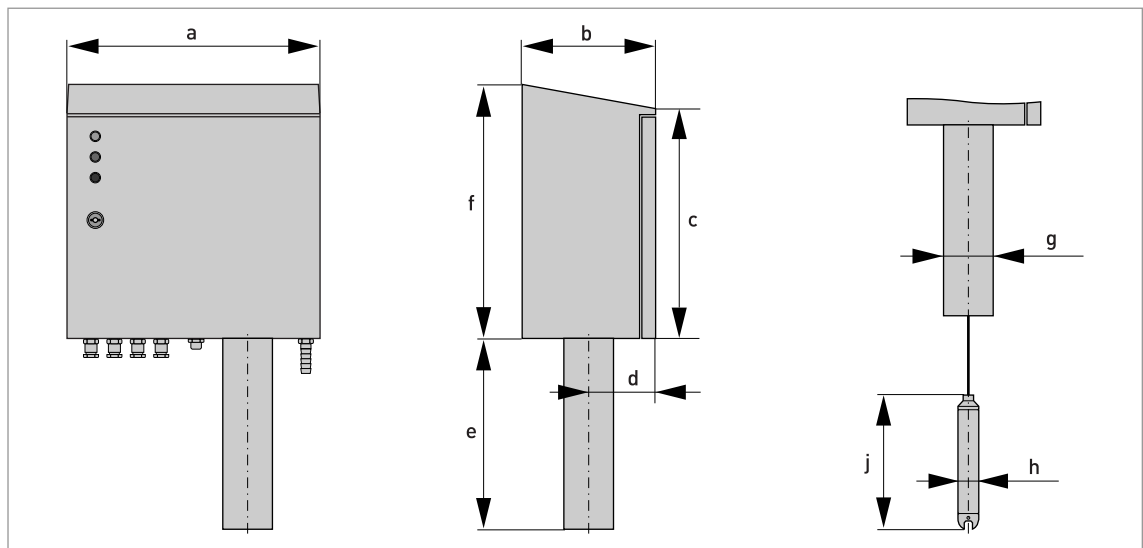

	Dimensions [cm]	Dimensions ["]	Weight	
			[kg]	[lbs]
a	40	15.7	20	44
b	21.1	8.3		
c	34	13.4		
d	10	3.9		
e	30	11.8		
f	40	15.8		
g	7.9	3.1		
h	3.3	1.3		
j	21.1	8.3		







KROHNE product overview

- Electromagnetic flowmeters
- Variable area flowmeters
- Ultrasonic flowmeters
- Mass flowmeters
- Vortex flowmeters
- Flow controllers
- Level meters
- Temperature meters
- Pressure meters
- Analysis products
- Measuring systems for the oil and gas industry
- Measuring systems for sea-going tankers

Head Office KROHNE Messtechnik GmbH
Ludwig-Krohne-Str. 5
D-47058 Duisburg (Germany)
Tel.: +49 (0)203 301 0
Fax: +49 (0)203 301 10389
info@krohne.de

The current list of all KROHNE contacts and addresses can be found at:
www.krohne.com

KROHNE