



OPTISENS OAS 2000 Handbook

Suspended solids sensor

Software version: 1.00

The documentation is only complete when used in combination with the relevant documentation for the converter.

All rights reserved. It is prohibited to reproduce this documentation, or any part thereof, without the prior written authorisation of KROHNE Messtechnik GmbH.

Subject to change without notice.

Copyright 2010 by
KROHNE Messtechnik GmbH - Ludwig-Krohne-Str. 5 - 47058 Duisburg (Germany)

1	Safety instructions	5
1.1	Software history	5
1.2	Intended use	5
1.3	Certifications	5
1.4	Safety instructions from the manufacturer	5
1.4.1	Copyright and data protection	5
1.4.2	Disclaimer	6
1.4.3	Product liability and warranty	7
1.4.4	Information concerning the documentation	7
1.4.5	Warnings and symbols used	8
1.5	Safety instructions for the operator	8
2	Device description	9
2.1	Scope of delivery	9
2.1.1	Scope of delivery	9
2.1.2	Scope of delivery	10
2.2	Device description	10
2.2.1	Design	11
2.3	Nameplates	11
2.3.1	OPTISENS OAS 2000	11
2.3.2	OPTISENS OAS 2000	12
3	Installation	13
3.1	Notes on installation	13
3.2	Storage and transport	13
3.3	Configuration of a measuring point	13
3.3.1	Single parameter measuring point	14
3.3.2	Two parameter measuring point	15
3.3.3	Four parameter measuring point	16
3.4	Mounting of submersible version	17
3.4.1	Mounting to MAA 2000 telescopic rod immersion holder	17
3.4.2	Mounting to MAA 2000 slide rail immersion holder	20
3.5	Installation of flushing	21
3.6	Mounting of inline version	23
4	Electrical connections	27
4.1	Safety instructions	27
4.2	Cable connections	27
5	Operation	28
5.1	Sensor display	28
5.2	Menu for OAS 2000 sensor	28
5.3	Calibration	30
5.3.1	Calibration Points	31

5.3.2 Negative values	31
5.3.3 Calibration screen.....	32
5.3.4 Automatic adjustment of the calibration	33
5.3.5 Statistic adjustment	34
5.3.6 Zero calibration	34
5.3.7 Calibration with samples	35
5.4 Scaling	36
6 Service	37
<hr/>	
6.1 Cleaning the flushing nozzle	37
6.2 Spare parts availability	37
6.3 Spare parts and accessories.....	37
6.4 Availability of services	38
6.5 Returning the device to the manufacturer.....	38
6.5.1 General information.....	38
6.5.2 Form (for copying) to accompany a returned device.....	39
6.6 Disposal	39
7 Technical data	40
<hr/>	
7.1 Measuring principle.....	40
7.2 Technical data.....	41
7.3 Dimensions and weight	43
8 Appendix	45
<hr/>	
8.1 Setup information form	45
8.2 Support information form	46
9 Notes	47
<hr/>	

1.1 Software history

Release date	Software version	Documentation
05/2008	1.00	MA OAS 2000 R01
10/2009	1.00	MA OAS 2000 R02

1.2 Intended use

The sensors are used to measure suspended solids in water and wastewater treatment plants and other industrial applications. They are designed to be combined with the MAC 080 converter.

1.3 Certifications



The device fulfils the statutory requirements of the following EC directives:

- Electromagnetic compatibility (EMC) in accordance with:
EN 61000-6-4:2001: Emission standard for industrial environments
EN 61000-6-2:2001: Immunity for industrial environments
- Low Voltage Directive:
Safety requirements for electrical equipment for measurement, control and laboratory use in accordance with EN 61010-1:2001.

The manufacturer certifies successful testing of the product by applying the CE marking.

1.4 Safety instructions from the manufacturer

1.4.1 Copyright and data protection

The contents of this document have been created with great care. Nevertheless, we provide no guarantee that the contents are correct, complete or up-to-date.

The contents and works in this document are subject to German copyright. Contributions from third parties are identified as such. Reproduction, processing, dissemination and any type of use beyond what is permitted under copyright requires written authorisation from the respective author and/or the manufacturer.

The manufacturer tries always to observe the copyrights of others, and to draw on works created in-house or works in the public domain.

The collection of personal data (such as names, street addresses or e-mail addresses) in the manufacturer's documents is always on a voluntary basis whenever possible. Whenever feasible, it is always possible to make use of the offerings and services without providing any personal data.

We draw your attention to the fact that data transmission over the Internet (e.g. when communicating by e-mail) may involve gaps in security. It is not possible to protect such data completely against access by third parties.

We hereby expressly prohibit the use of the contact data published as part of our duty to publish an imprint for the purpose of sending us any advertising or informational materials that we have not expressly requested.

1.4.2 Disclaimer

The manufacturer will not be liable for any damage of any kind by using its product, including, but not limited to direct, indirect, incidental, punitive and consequential damages.

This disclaimer does not apply in case the manufacturer has acted on purpose or with gross negligence. In the event any applicable law does not allow such limitations on implied warranties or the exclusion of limitation of certain damages, you may, if such law applies to you, not be subject to some or all of the above disclaimer, exclusions or limitations.

Any product purchased from the manufacturer is warranted in accordance with the relevant product documentation and our Terms and Conditions of Sale.

The manufacturer reserves the right to alter the content of its documents, including this disclaimer in any way, at any time, for any reason, without prior notification, and will not be liable in any way for possible consequences of such changes.

1.4.3 Product liability and warranty

The operator shall bear responsibility for the suitability of the device for the specific purpose. The manufacturer accepts no liability for the consequences of misuse by the operator. Improper installation and operation of the devices (systems) will cause the warranty to be void. The respective "Standard Terms and Conditions" which form the basis for the sales contract shall also apply.

1.4.4 Information concerning the documentation

To prevent any injury to the user or damage to the device it is essential that you read the information in this document and observe applicable national standards, safety requirements and accident prevention regulations.

If this document is not in your native language and if you have any problems understanding the text, we advise you to contact your local office for assistance. The manufacturer can not accept responsibility for any damage or injury caused by misunderstanding of the information in this document.

This document is provided to help you establish operating conditions, which will permit safe and efficient use of this device. Special considerations and precautions are also described in the document, which appear in the form of underneath icons.

1.4.5 Warnings and symbols used

Safety warnings are indicated by the following symbols.



DANGER!

This information refers to the immediate danger when working with electricity.



DANGER!

This warning refers to the immediate danger of burns caused by heat or hot surfaces.



DANGER!

This warning refers to the immediate danger when using this device in a hazardous atmosphere.



DANGER!

These warnings must be observed without fail. Even partial disregard of this warning can lead to serious health problems and even death. There is also the risk of seriously damaging the device or parts of the operator's plant.



WARNING!

Disregarding this safety warning, even if only in part, poses the risk of serious health problems. There is also the risk of damaging the device or parts of the operator's plant.



CAUTION!

Disregarding these instructions can result in damage to the device or to parts of the operator's plant.



INFORMATION!

These instructions contain important information for the handling of the device.



LEGAL NOTICE!

This note contains information on statutory directives and standards.



• **HANDLING**

This symbol designates all instructions for actions to be carried out by the operator in the specified sequence.

➔ **RESULT**

This symbol refers to all important consequences of the previous actions.

1.5 Safety instructions for the operator



WARNING!

*In general, devices from the manufacturer may only be installed, commissioned, operated and maintained by properly trained and authorized personnel.
This document is provided to help you establish operating conditions, which will permit safe and efficient use of this device.*

2.1 Scope of delivery



INFORMATION!

Inspect the cartons carefully for damage or signs of rough handling. Report damage to the carrier and to the local office of the manufacturer.



INFORMATION!

Check the packing list to check if you received completely all that you ordered.



INFORMATION!

Look at the device nameplate to ensure that the device is delivered according to your order. Check for the correct supply voltage printed on the nameplate.

2.1.1 Scope of delivery

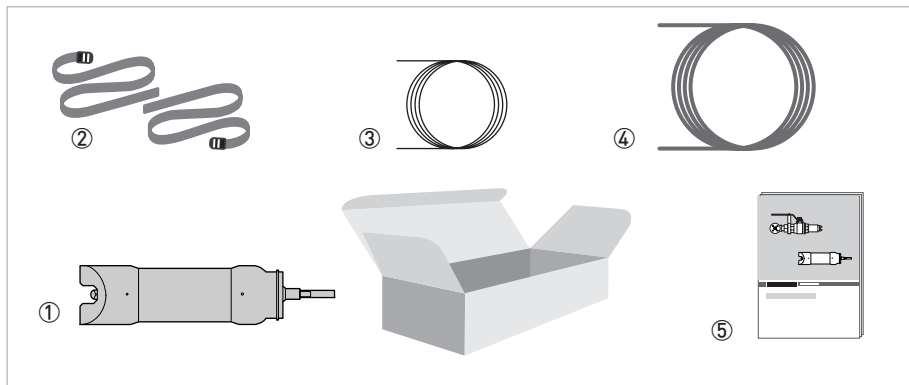

Figure 2-1: Scope of delivery OAS 2000 submersible version

- ① OAS 2000 suspended solids sensor (submersible version)
- ② 2 straps
- ③ 10 m / 33 ft signal cable
- ④ 10 m / 33 ft flush hose
- ⑤ Handbook

Optional accessories for OAS 2000 submersible version (if ordered)

- MAA 2000 insertion holder, telescopic rod for OAS/AAS 2000 (incl. telescopic rod plus rod holder, handrail mounting bracket and sensor adapter)
- MAA 2000 side wall mounting for OAS/AAS 2000
- Signal cable extension for OPTISENS 2000 sensors (10 m / 33 ft)
- Signal cable extension for OPTISENS 2000 sensors (30 m / 98 ft)

2.1.2 Scope of delivery

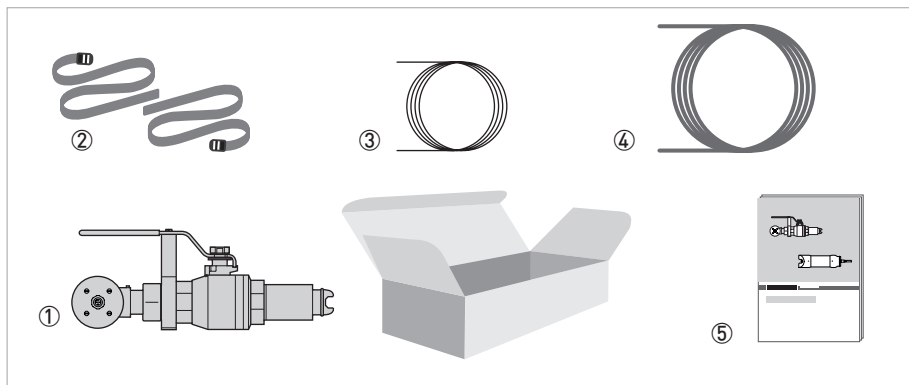

Figure 2-2: Scope of delivery OAS 2000 inline version

- ① OAS 2000 suspended solids sensor (inline version), connection valve, but weld end R 1½" for pipe mounting.
Optional: OAS 2000 suspended solids sensor (inline version) without connection valve and but weld end.
- ② 2 straps
- ③ 10 m / 33 ft signal cable
- ④ 10 m / 33 ft flush hose
- ⑤ Handbook

Optional accessories for OAS 2000 inline version (if ordered)

- Signal cable extension for OPTISENS 2000 Sensors (10 m / 33 ft)
- Signal cable extension for OPTISENS 2000 Sensors (30 m / 98 ft)
- OAS 2000 inline connection valve
- OAS 2000 inline but weld end R 1½" for pipe mounting
- OAS 2000 inline 1/12" NPT nipple
- Sealing kit for OAS 2000 inline-version: flush membrane, o-ring between valve and adapter 48 x 2 EP70, o-ring in the adapter 33.3 x 2.4 EP70, o-ring on OAS 2000 inline 29 x 2.5 EP70

2.2 Device description

The sensor is designed to measure suspended solids concentrations in liquids. Combined with the MAC 080 converter, the sensor is used to measure suspended solids content as a function of the ability of suspended materials to absorb and reflect NIR-light (Near Infrared). The sensor is available in two versions, for inline mounting and for submersion.

This manual details installation procedures and operational features of the sensor. Menu navigation and technical data for the converter can be found in the converter manual.

2.2.1 Design

The sensor is manufactured with 316SS (SS2343) Stainless Steel. The head of the sensor is designed to achieve the highest self-cleaning effect, providing an exact and reliable measurement with the least possible maintenance under critical applications. The measuring lenses within the housing are made of glass. The electronics and optics are protected in the rugged casing, ensuring its reliability in very demanding environments.

The sensor has a fixed, shielded 10 m / 33 ft cable used for signal transmission between the sensor and the converter. The cable sheath is made of Hytrel and is highly resistant to aggressive materials and fluids.

The inline version of the sensor has a M12 connector to connect a standard OPTISENS 2000 cable to the converter.

2.3 Nameplates



INFORMATION!

Look at the device nameplate to ensure that the device is delivered according to your order. Check for the correct supply voltage printed on the nameplate.

2.3.1 OPTISENS OAS 2000

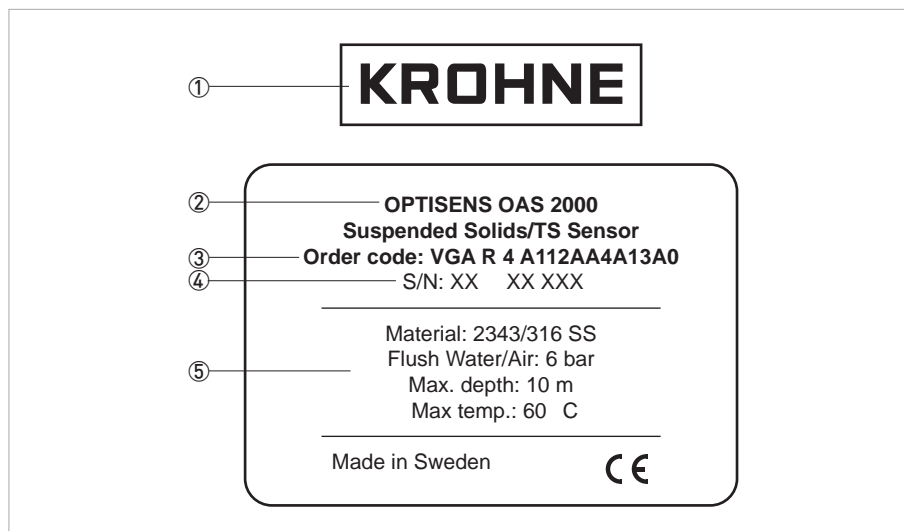

Figure 2-3: Nameplate OPTISENS OAS 2000 submersible version

- ① Manufacturer
- ② Device type
- ③ Order code
- ④ Serial number
- ⑤ Sensor information

2.3.2 OPTISENS OAS 2000

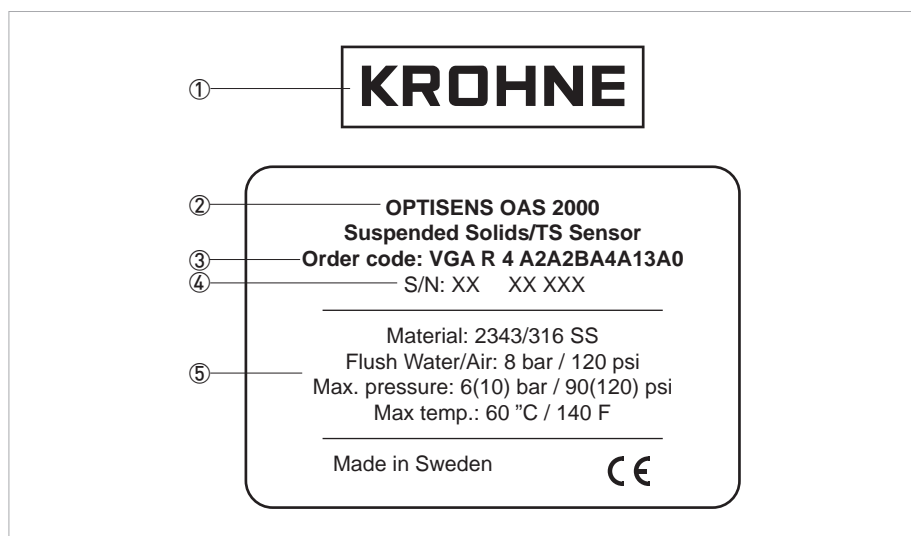

Figure 2-4: Nameplate OPTISENS OAS 2000 inline version

- ① Manufacturer
- ② Device type
- ③ Order code
- ④ Serial number
- ⑤ Sensor information

3.1 Notes on installation

**INFORMATION!**

Inspect the cartons carefully for damage or signs of rough handling. Report damage to the carrier and to the local office of the manufacturer.

**INFORMATION!**

Check the packing list to check if you received completely all that you ordered.

**INFORMATION!**

Look at the device nameplate to ensure that the device is delivered according to your order. Check for the correct supply voltage printed on the nameplate.

3.2 Storage and transport

- Store the device in a dry, dust-free location.
- Avoid continuous direct sunlight.
- The original packing is designed to protect the equipment. It has to be used if the device is transported or sent back to the manufacturer.

3.3 Configuration of a measuring point

A complete measuring point consists of at least three parts:

- MAC 080 converter
- OPTISENS 2000 sensor (including cable)
- MAA 2000 sensor holder

If automatic flushing is installed, an optional solenoid valve is necessary as well.

Examples of typical measuring points are listed in the following sections.

3.3.1 Single parameter measuring point

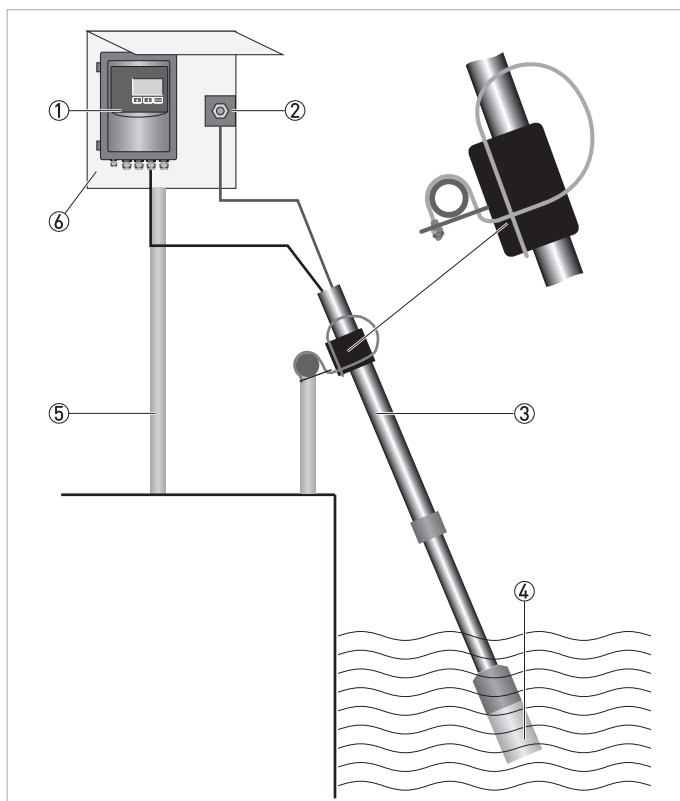

- ① Converter
- ② Solenoid valve for flushing (to be ordered with converter)
- ③ Mounting assembly
- ④ Sensor incl. 10 m / 33 ft cable and flush hose
- ⑤ Mounting post
- ⑥ Mounting plate with sun shield

The figure above shows a single parameter measuring point consisting of one converter ①, one sensor ④ with a telescopic rod immersion assembly as sensor holder ③ and one solenoid valve ② for flushing.

The spring loaded mounting bracket for installation of the telescopic rod sensor holder on the handrail is included in the delivery of the holder and can be used for round and square hand rails with a maximum diameter of 50 mm / 2".

The signal cable to the sensor and the flush hose are provided with the sensor.

The mounting plate with sun shield and the mounting post are available optional.

3.3.2 Two parameter measuring point

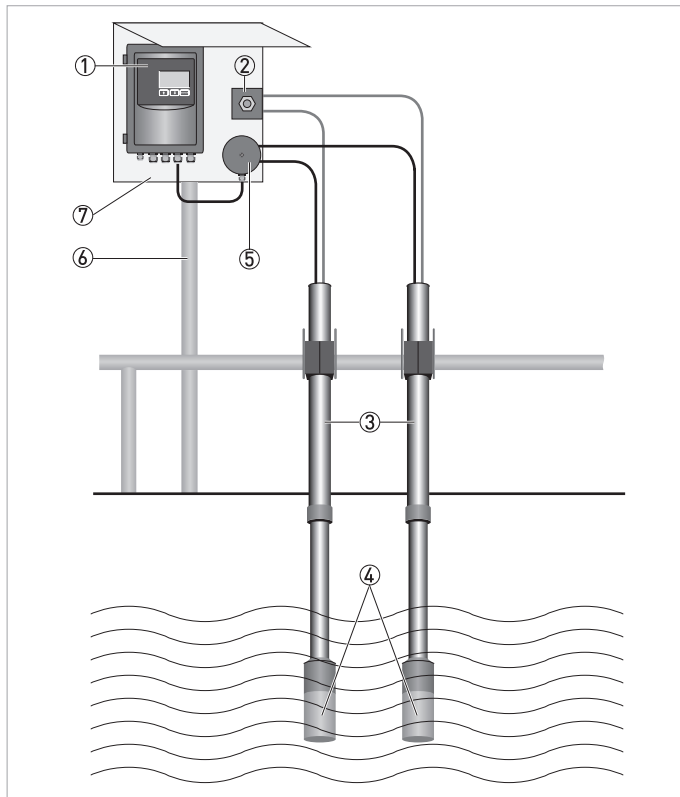

- ① Converter
- ② Solenoid valve for flushing (to be ordered with converter)
- ③ Mounting assembly
- ④ Sensor incl. 10 m / 33 ft cable and flush hose
- ⑤ Junction box for connection of up to 4 sensors (to be ordered with converter)
- ⑥ Mounting post
- ⑦ Mounting plate with sun shield

The figure above shows a two parameter measuring point consisting of one converter ①, two sensors ④ with a telescopic rod immersion assembly as sensor holder ③ and one solenoid valve ② for flushing.

Both sensors are flushed via one solenoid valve using an optional Y-splitter.

For connection of two sensors to the converter an optional junction box is needed.

3.3.3 Four parameter measuring point

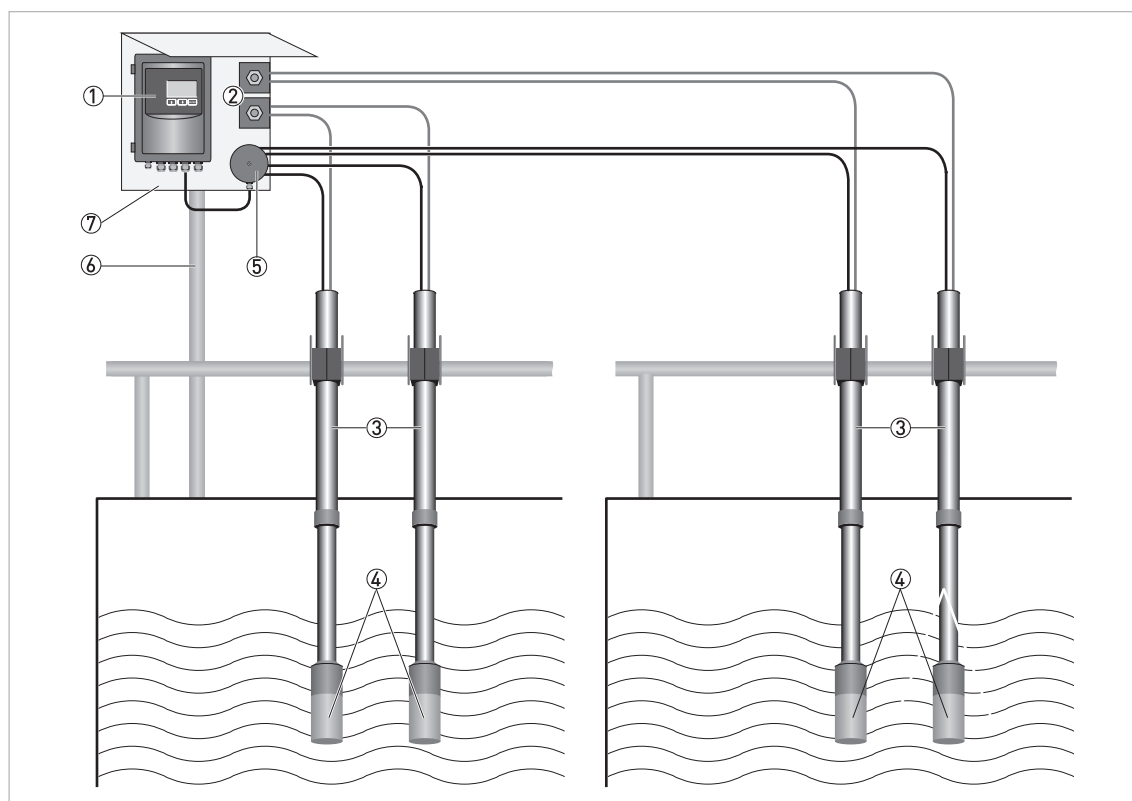

- ① Converter
- ② Solenoid valve for flushing (to be ordered with converter)
- ③ Mounting assembly
- ④ Sensor incl. 10 m / 33 ft cable and flush hose
- ⑤ Junction box for connection of up to 4 sensors (to be ordered with converter)
- ⑥ Mounting post
- ⑦ Mounting plate with sun shield

The figure above shows a four parameter measuring point consisting of one converter ①, four sensors ④ with a telescopic rod immersion assembly as sensor holder ③ and two solenoid valves ② for flushing.

Two sensors each are flushed via one solenoid valve using an optional Y-splitter.

For connection of four sensors to the converter an optional junction box is needed.

3.4 Mounting of submersible version

The sensor can be mounted in two ways:

- On a telescopic fibreglass rod placed in a mounting bracket that fastens to a handrail (see next section).
- To an adjustable slide rail holder (see next section but one).

Installation tips

- When the sensor measures in a flume, it is important to find a place where the suspended solids concentration is representative.
- Make sure the flushing nozzle is downstream from the lenses pointing against the stream. This will avoid disturbances of the measurement by turbulence from the nozzle. At the same time it will produce a shield around the nozzle, due to a constant over pressure, preventing particles from getting in.
- Adjust the rod so that the sensor is at least 30 cm / 11.8" below the liquid surface or the lowest water level in decant applications to prevent the sensor from coming out of the liquid.
- In an aeration tank, ensure that the sensor is not directly above a diffuser head. It should be installed on the backside of the rolling diffuser effect.
- Flushing may not be required if the tank is well agitated. To verify the need for flushing, remove the sensor from the liquid after it has been in the liquid for several days.
- When installing in a clarifier, compressed air flushing is required due to no agitation of liquid and to remove oil and grease film on lens. This is especially applicable in primary clarifiers.
- When using the sensor for influent applications, always install the unit after the bar screen. If the bar screen spacing is larger than 6 mm / 0.24", then a baffle or diffuser plate should be installed in front of the sensor to prevent rags from catching on the sensor head. On influent applications, compressed air flushing is recommended due to the oil or grease in the liquid.

3.4.1 Mounting to MAA 2000 telescopic rod immersion holder

The mounting bracket of the telescopic rod is mounted to a handrail or a separate holder. In case a handrail is not available, a mounting post with a vertical bar for sensor mounting can be purchased from the manufacturer.

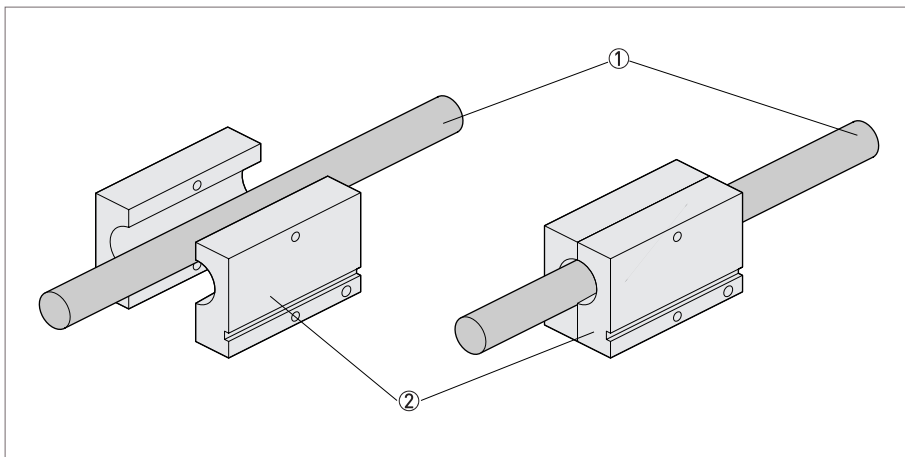

Figure 3-1: Placing the rod holder around the rod

- ① Telescopic rod
- ② Rod holder

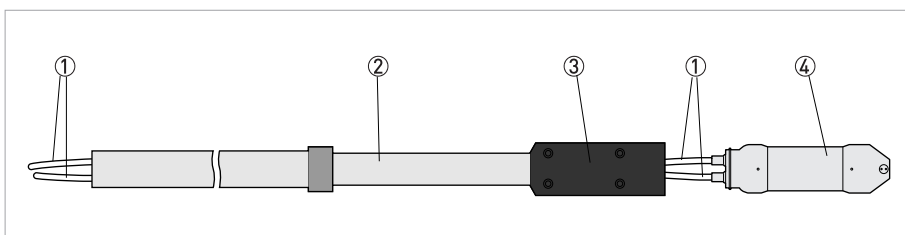

Figure 3-2: Pulling the cable/hose through the rod

- ① Cable/hose
- ② Telescopic rod
- ③ Sensor holder
- ④ Sensor

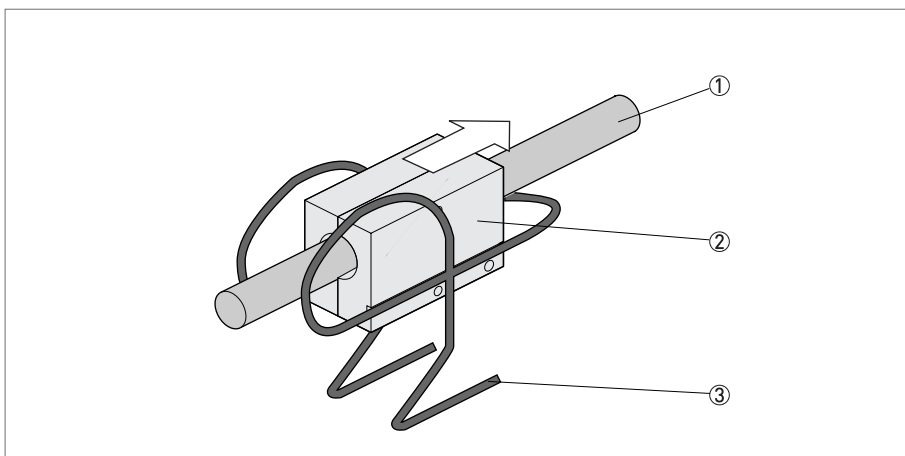
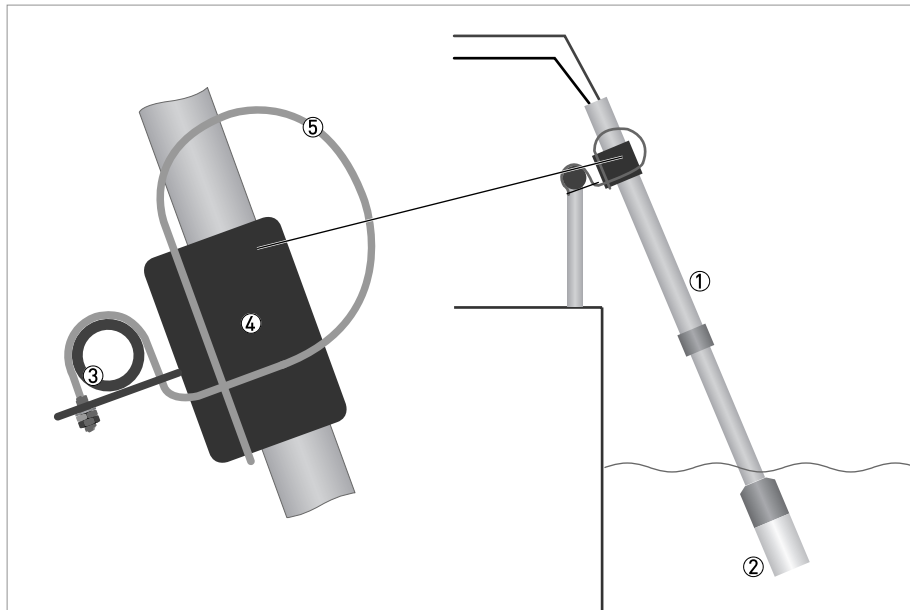

Figure 3-3: Inserting the rod holder into the mounting bracket

- ① Telescopic rod
- ② Rod holder
- ③ Mounting bracket



- ① Telescopic rod
- ② Sensor holder
- ③ Handrail with mounting bracket attached
- ④ Rod holder
- ⑤ Mounting bracket

**CAUTION!**

Do not extend the rod sections beyond the black lines. This could lead to rod damage.

**INFORMATION!**

For best measurement, the rod shall be mounted in an angle (5...30° from vertical).



Mounting to telescopic rod immersion holder

- Mount the flexible mounting bracket on an existing handrail or on a separate holder, diameter 32...50 mm / 1.3...2.0" or square 28...42 mm / 1.1...1.7". The bent lip on the mounting plate shall be on top and faced toward the liquid or tank.
- Adjust the mounting bracket to the correct angle and tighten the nuts.
- ☞ The bracket shall be fixed to the rail and must not be able to rotate around it.
- Disassemble the rod holder and place it around the telescopic rod.
- Use the SS screws on the rod holder to tighten the rod holder to the rod.
- Pull the cable and hose through the sensor holder and rod.
- Connect the sensor to the rod with the two piece black PVC sensor holder.
- Tighten the adapter halves until snug, which will leave about 1.5 mm / 0.06" gap. The gap is required so the water can drain from the rod.
- Adjust the length of the telescopic rod as necessary by twisting the nuts while holding the rod. Do not extend the rod sections beyond the black lines. This could lead to rod damage.
- Insert the PVC rod holder with the telescopic rod into the mounting bracket. Make sure that the guide tracks of the rod holder are properly seated in the bracket.
- Fasten the safety-locking clamp.
- Check that the mounting bracket is safely fixed to the rail for the spring to work the way it is intended.

3.4.2 Mounting to MAA 2000 slide rail immersion holder

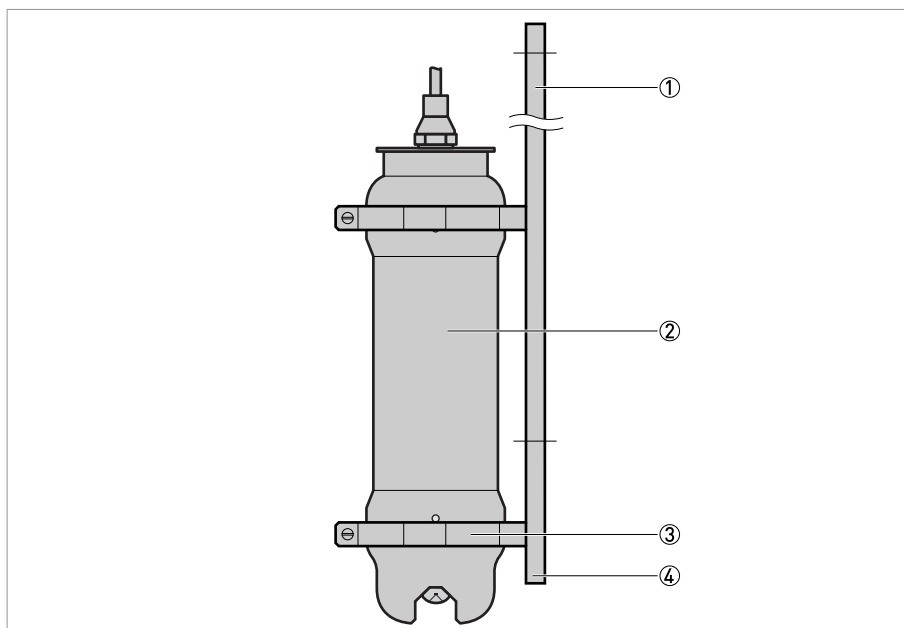

Figure 3-4: Mounting to MAA 2000 slide rail immersion holder

- ① Slide rail immersion holder
- ② Sensor
- ③ 66 mm / 2.60" clamp
- ④ Adjustable stop

**CAUTION!**

In order to avoid large air bubbles which can affect the measurement please make sure that the slide rail immersion holder is mounted in a certain angle to the vertical position. The angle should be slightly off from vertical position (approx. 20°), but not more than 90°.

**Mounting to MAA 2000 slide rail immersion holder**

- Mount the slide rail immersion holder to the side wall of the basin or open channel using the two predrilled holes. The adjustable stop should be on the bottom and the two sliding clamps above.
- Take the two sliding clamps off from the slide rail and mount them around the sensor housing. Make sure that the clamps are placed on the two elevated ends of the sensor housing (one on the upper part and one on the lower part, see figure above). The two guide tracks have to line-up in one straight line to each other.
- Slide the sensor with the two clamps into the slide rail. Make sure that the guide tracks of the two clamps are properly seated.
- Adjust the sensor position as necessary and fasten the adjustable stop.

3.5 Installation of flushing

The sensor is equipped with built-in flushing nozzles. The nozzles are used to direct the cleaning medium (compressed air or water) via a flushing hose that is connected to the top of the sensor housing. A solenoid valve that is wired to a relay in the converter controls the air or liquid (see converter manual).

Compressed air is recommended for most applications.

**CAUTION!**

For the submersible sensor the highest allowed flushing pressure is 6 bar / 87 psi. When using air, 2 bar / 29 psi is usually sufficient.

**CAUTION!**

For the inline sensor the highest allowed flushing pressure is 8 bar / 116 psi. Inline sensors require a flushing pressure at least 2 bars / 29 psi above the process pressure.

**INFORMATION!**

Pay attention to the requirements for protection against backflow, according to the EN 1717 standard for drinking water devices. If possible, use plant reuse water or effluent water for cleaning.

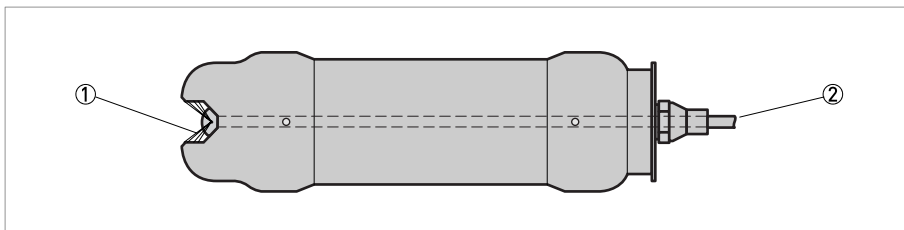

Figure 3-5: Flushing system

- ① Flushing
- ② Flushing tube



INFORMATION!

*In order to clean the sensor, flushing must be activated in the **Settings** menu of the converter.*

There are two different ways of cleaning a sensor: The sensor can either be cleaned as a master or as a slave. Both options are described in the following instructions.



Cleaning the sensor as a master (sensor has its own relay)

- Select the sensor in the main menu by using ↑ or ↓.
- Press ← for approximately 5 seconds to enter the sensor menu.
- Use ↑ or ↓ to select **Cleaning** and press ←.
- In the **Cleaning** submenu, select **Cleaner** and set it to **Flush**.
- Then specify the cleaning interval in minutes (**Interval min**) and the flush time in seconds (**Length sec**).
- Specify the relay to be used according to the wiring inside the converter. For example, if the solenoid is wired to relay #1, set **Relay** to **#1** for flushing.
- For sensors configured as masters, **Next time** displays that the next time flush will be activated. Pushing ← will set it to current time and thus start cleaning.
- If needed, specify the extra freeze time in seconds (**Freeze sec**).



Cleaning the sensor as a slave (along with another sensor)

- Select the sensor in the main menu by using ↑ or ↓.
- Press ← for approximately five seconds to enter the sensor menu.
- Use ↑ or ↓ to select **Cleaning** and press ←.
- The parameters **Cleaner**, **Interval min** and **Length sec** in the **Cleaning** submenu are set for the sensor being the master.
- Set **Relay** to **Along #1** or **Along #2** depending on what relay the master sensor uses.
- If needed, specify the extra freeze time in seconds (**Freeze sec**).

3.6 Mounting of inline version



CAUTION!

Be aware that the force may be strong when the sensor is mounted under pressure.



CAUTION!

If the following instructions cannot be fulfilled in all parts, the sensor should not be mounted or dismantled under process pressure.

The inline sensor is mounted through a ball valve to make it possible to remove the sensor under pressure. Make sure there is at least 260 mm / 10.2" free space to remove the sensor from the valve. The sensor shall be mounted in a place where the process pressure is at least 1 bar. In horizontal pipes the sensor shall be mounted from the side or from below to avoid disturbance from air bubbles.

The sensor is designed to be mounted in a right angle to the process flow. The smallest process pipe diameter to mount the sensor is 80 mm / 3.1". The measure gap must be at least 5 mm / 0.2" from the pipe wall. If a sample outlet is used it must reach at least 20 mm / 0.8" into the pipe.

Place the sensor at a location where there is no risk for it to get damaged. When the OAS 2000 inline is used outdoors, it shall be mounted with a sun and rain protective hood.

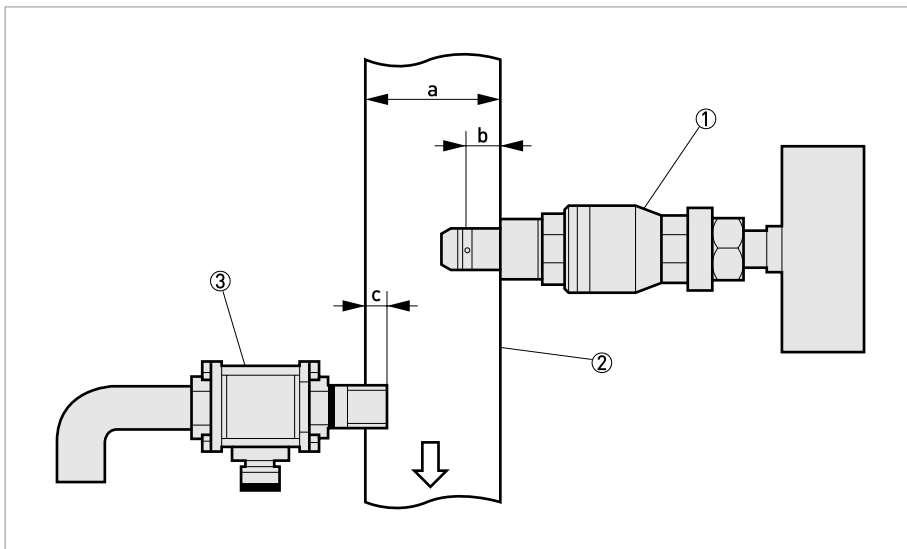

Figure 3-6: Mounting of sensor and sample outlet

- ① Inline sensor with ball valve
- ② Process pipe
- ③ Sample outlet

	Dimensions [mm]	Dimensions [inches]
a	min. 80 mm	min. 3.1"
b	min. 5 mm	min. 0.2"
c	min. 20 mm	min. 0.8"

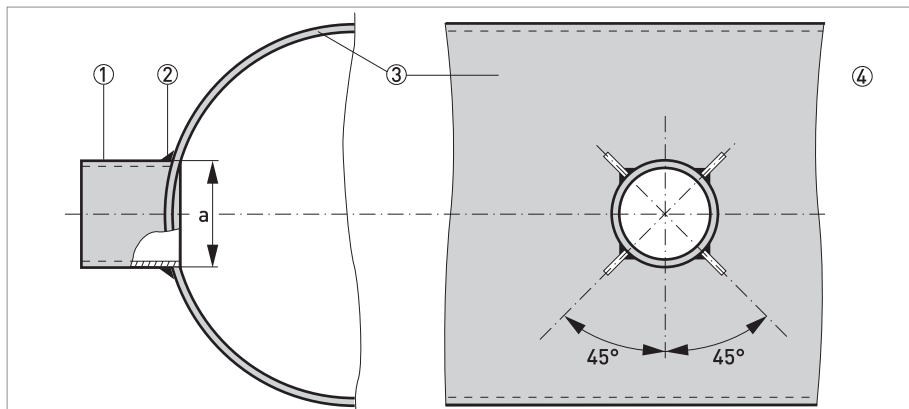

Figure 3-7: Mounting of weld end with strip iron

- ① Weld end
- ② Weld
- ③ Process pipe
- ④ Stabilizing weld

	Ø [mm]	Ø [inches]
a	48.5	1.91



Mounting the weld end (see previous figure)

- Open a Ø 48.5 mm / 1.91" hole in the process pipe.
- Cut the weld end to get the sensor head at least 5 mm / 0.2" from the pipe wall.
- Weld the weld end to the pipe.
- Stabilize the weld end using 3 mm / 0.1" strip iron according to the figure above.



Mounting the optional threaded nipple in a saddle

- Mount the saddle on the pipe according to the saddle manufacturer's instructions.
- Thread the nipple into the saddle.
- Use flaxen hair and joint paste. Be aware to get the correct distance from the pipe wall to the valve.

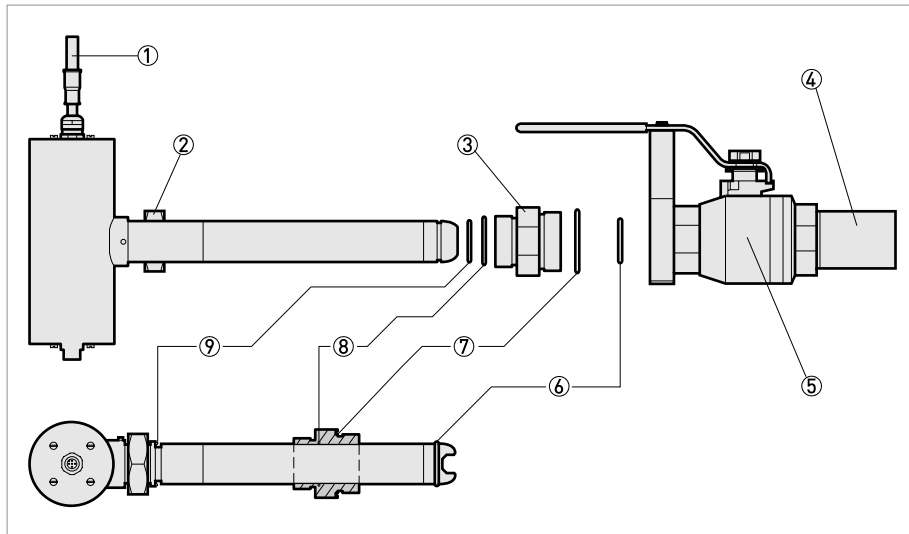

Figure 3-8: Mounting of sensor in ball valve

- ① Flush hose
- ② Sensor nut
- ③ Adapter
- ④ Weld end nipple or 1½" NPT threaded nipple
- ⑤ Ball valve
- ⑥ Lockring
- ⑦ O-ring 48 x 2 mm / 1.9 x 0.1"
- ⑧ O-ring 33.3 x 2.4 mm / 1.3 x 0.1"
- ⑨ O-ring 29 x 2.5 mm / 1.1 x 0.1"



Mounting the ball valve (see previous figure)

- Thread the valve end on the but weld end or nipple (use sealing tape or flaxen hair and joint paste).



INFORMATION!

Don not pull the valve end to the bottom. The valve handle plane shall have the same direction as the pipe. If the valve is turned the wrong way, the measuring gap will not be in line with the flow, resulting in faulty measurement.

The sensor is mounted in the valve using an adapter. The adapter serves two purposes:

1. A thread for the sensor nut to keep the sensor in place.
2. A stop for the lockring to prevent the sensor from coming loose when the sensor nut is loosened.

**CAUTION!**

Be careful that the sensor is inserted straight. If the sensor is not straight, it can jam and so cause damages on the transmitter or valve.

**CAUTION!**

If the transmitter is hard to mount and you suspect something that is stuck or the transmitter is not mounted straight, crank out and check that everything is OK.

**CAUTION!**

The Sensor nut can release big forces. Do not ever loosen the nut without holding the sensor in place at the same time.

**Mounting the sensor (see previous figure)**

- Make sure that the o-rings in the adapter between the sensor and the valve and on the sensor below the sensor nut are in a faultless condition.
- Use silicon grease or soup to grease the o-rings before mounting the adapter.
- If the adapter is separated from the sensor, check and grease the o-ring inside the adapter. Then push the adapter over the sensor head having the smaller thread towards the sensor housing.
- Mount the lockring on the sensor head.
- Thread the adapter into the valve.
- ➡ The sensor is now fixed to the valve.
- When the adapter is tightened, open the valve.
- Push the sensor in place. If the process pressure is high, considerable force may be needed to push the sensor in place.
- Screw the sensor nut in place, but do not tighten it yet.
- Align the sensor in parallel with the process flow.
- Tighten the sensor nut.
- ➡ The sensor is mounted.

4.1 Safety instructions

**DANGER!**

All work on the electrical connections may only be carried out with the power disconnected. Take note of the voltage data on the nameplate!

**DANGER!**

Observe the national regulations for electrical installations!

**DANGER!**

For devices used in hazardous areas, additional safety notes apply; please refer to the Ex documentation.

**WARNING!**

Observe without fail the local occupational health and safety regulations. Any work done on the electrical components of the measuring device may only be carried out by properly trained specialists.

**INFORMATION!**

Look at the device nameplate to ensure that the device is delivered according to your order. Check for the correct supply voltage printed on the nameplate.

4.2 Cable connections

The sensor is equipped with a fixed 10 m / 33 ft cable, which has a M12 connector attached. Connect the sensor to the converter using the M12 connector. In the event that two or more sensors should be connected to the same converter, use the optional junction box.

Power requirements:

- The sensor requires 24 VDC power, which is supplied from the converter via the sensor cable.
- The maximum current during operation is 45 mA.

5.1 Sensor display

By simultaneously pressing ↓ and ← you alter between the converter main menu and the sensor information display for the selected sensor. The sensor information display shows the sensor's calibration curve.

5.2 Menu for OAS 2000 sensor

Use ↑ or ↓ to select the sensor in the main display. The menu for the selected sensor is accessed by pressing ← for five seconds. If the selected sensor is not active (the text **No transmitter** is shown) a warning is displayed that asks you to make another choice in order to show the sensor menu.

Menu "Settings"

Submenu	Description
Tag	Name of the sensor shown in the main display (10 characters).
I-Time	Integration time or dampening (can be set up to 999 seconds).
Unit	"%", "ppm", "g/l", "mg/", NTU, FNU
Decimals	"Std" or "Extra". Number of decimals for the reading.
Analog	"None", "Out1", "Out2", "Out3", "Out4", "Out1+2" or "Out3+4". Pick which analog output(s) should be used with sensor.
Second	"Temp" or "=Prim". If two analog outputs are chosen above, the first will always give the primary value according to the sensors selected scale. The second will either give the temperature scaled 0...100°C / 32...212°F, or the same signal as the first channel. The temperature is additional information, not a precision measurement.

Menu "Calibrate"

Submenu	Description
Adjust	"No", "Store" or "Lab". Stores the reading of the meter when a sample is taken and can then automatically adjust the sample value when the sample analysed by lab is different to the reading.
Take sample	"No", "Zero", "1", "2", "3", "4", "5". Sensor stores current MS (light) value in memory and you enter a lab solids value below to complete calibration.
Con	Current concentration (same as shown in the main menu).
Sample 1	Lab test (suspended solids value for Sample 1)
Sample 2	Lab test (suspended solids value for Sample 2)
Sample 3	Lab test (suspended solids value for Sample 3)
Sample 4	Lab test (suspended solids value for Sample 4)
Sample 5	Lab test (suspended solids value for Sample 5)

Menu "Cleaning"

Submenu	Description
	Press \leftarrow to go to the cleaning program
Cleaner	"None", "Flush" or "Brush". Do not select "Brush" since this does not exist for this sensor (only for master).
Interval min	0...999 minutes, time between cleaning cycles (only for master).
Length sec	0...999 seconds, duration of flushing cycle (only for master).
Freeze sec	0...999 seconds, extra freeze time of output signal after a flushing cycle.
Relay	"-", "1", "2", "Along 1" or "Along 2". Select relay to operate solenoid for flush cycle if this sensor is a master with its own relay, or relay used by master if this sensor is a slave. These are the same relays used for Alarm relay below.
Next time	The next scheduled cleaning time. Pushing \leftarrow on this line will set the time to current time and start a cleaning cycle. This could be used to test the flush cycle (only for master).

Menu "Scale / Alarm"

Submenu	Description
Max	0...99.9 % or 0...99999.9 ppm, mg/l or g/l (units selected in the menu "Settings"), equal to 20 mA output signal.
Min	0...99.9 % or 0...99999.9 ppm, mg/l or g/l (units selected in the menu "Settings"), equal to 4 mA output signal.
Hi-Alarm	0...99.9 % or 0...99999.9 ppm, mg/l or g/l (units selected in the menu "Settings"), the value zero inactivates the alarm.
Low-Alarm	0...99.9 % or 0...99999.9 ppm, mg/l or g/l (units selected in the menu "Settings"), the value zero inactivates the alarm.
Alarm Relay	"-", "1", "2", or "1 and 2". Check that the relay is not being used for cleaning.

Menu "System"

Submenu	Description
Type	Type of sensor (read only)
Serial	Serial number of the sensor (read only)
SoftW	Software version of the sensor (read only)
Temp	Sensor temperature (read only)
MaxTemp	The highest temperature the sensor has been exposed to (read only)
Samples	Press ← to view SA values and suspended solids values.
SA 0	SA value for zero sample
SA 1	SA value for sample 1
Cons 1	Lab test (suspended solids value for sample 1)
...	SA and Cons repeated for samples 2 to 5
Info	Press ← to go to menu " Info " (read only). This menu is for KROHNE internal use, it may change without notice.
MS	Linearised light signal, which are SA values in calibration chart.
Con	Unit value in %, ppm, mg/l or g/l after MS value has been converted to units due to sample values. This is displayed on main screen.
SA 0	SA value for zero sample
SA 1	SA value for sample 1
Cons 1	Lab test (suspended solids value for sample 1)
Ch1a	Raw value for channel 1
Ch1	Raw value for channel 1, compensated for changed intensity.
Ch2	Raw value for channel 2
Intensity	Currently used intensity
Zero Int	Intensity for clear water, set during zero calibration.
I-offset	Intensity offset, set during zero calibration.
Samp/s	Number of samples per second
Service	Not accessible for users

5.3 Calibration

The MAC 080 has a self-optimizing calibration algorithm able to handle several calibration points in order to give maximum measuring precision in difficult applications. However, a single point calibration is usually preferred.

After a calibration has been carried out, make it a habit to look at the calibration curve in the sensor information screen to make sure it represents a smooth line without any sharp bends.



- Leave the instrument turned on for about 30 minutes prior to calibration so that the sensor and electronics can stabilize.
- Please check that the correct unit is selected for the application. In the sensor menu, select **Settings > Unit**.

5.3.1 Calibration Points

To calculate the consistency or concentration out of the loss of light the sensor uses a calibration curve. The curve is built up of the zero calibration point and at least one calibration point. Each point has a sample value and a consistency value. To be used a point needs both values. The sample value is set by **Calibrate > Take sample** in the calibration menu. The consistency value is manually entered in the same menu after having analysed the actual consistency at the time the sample was taken.

A calibration point can be disabled by setting the consistency value to zero. In most applications one calibration point in addition to the zero sample is the best solution, adding more samples then just confuses the measurement. Only in the following cases a multipoint calibration is needed:

1. The measurement turns out to be non linear.
2. The sensor needs to be very accurate at widely separated consistencies.

The zero calibration defines the zero point used as a reference for all other calibration points. The other points define the relation between loss of light and real consistency.

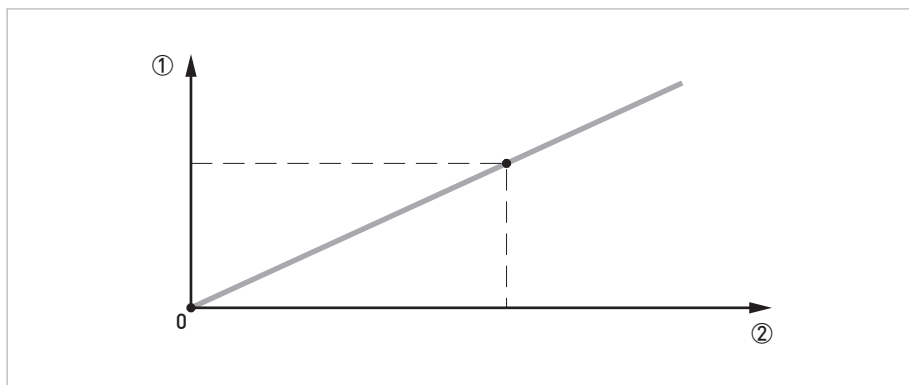

Figure 5-1: Example of a calibration curve

- ① Loss of light
- ② Consistency

5.3.2 Negative values

The sensor continuously compares the loss of light to its calibrated points. If, for some reason, the loss of light is less than when the sensor was zero-calibrated, the sensor shows a negative consistency. This is not a fault, it just indicates the liquid in the sensor absorbs less light than the liquid used as zero reference. Please contact the manufacturer if this is a problem for you.

5.3.3 Calibration screen

The sensor information menu is the calibration curve screen. To change between the main menu and the calibration screen, press ↓ and ← simultaneously.

The converter uses at least a zero sample and one sample (single point calibration). Up to five samples may be used to create a calibration curve (multipoint calibration).



INFORMATION!

The sample number itself does not change, only the order in which the samples are used.

The calibration menu displays sample values placed in a graph.

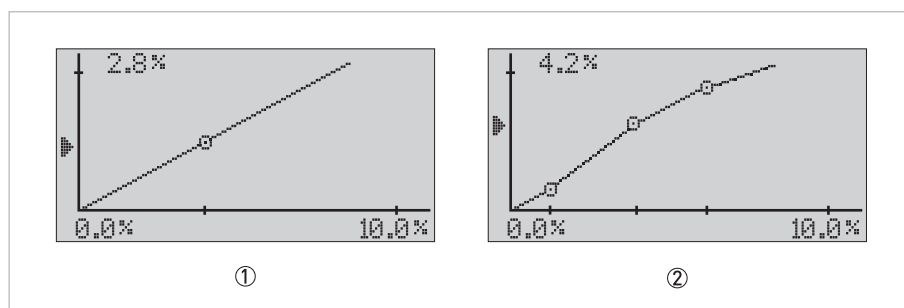

Figure 5-2: Calibration screen

- ① Single point calibration
- ② Multi point calibration

- The X-scale displays consistency/suspended solids, where **min** value (4 mA output) is shown on the left and **max** value (20 mA output) is shown on the right.
- The Y-scale displays the light loss due to solids from the sensor light source. The converter uses the light loss values to calculate which measuring signal corresponds to min-consistency/suspended solids and max-consistency/suspended solids.
- The actual measuring value is indicated with an arrow that moves up and down to the left of the Y-scale axis.
- Samples that are not within the chosen scale of the active sensor are not displayed on the calibration screen. However, these samples are still used in the calculations. If you want to see a point outside the sensor scale, then you may temporarily change the scale in the sensor menu **Scale/Alarm**.

If the sample values are switched or the lab result is incorrectly performed, then the calibration curve will be incorrect. Such a mistake is easy to discover on the calibration screen since a part of the calibration curve will go in the wrong direction. Different measuring values should never correspond to the same consistency/suspended solids.

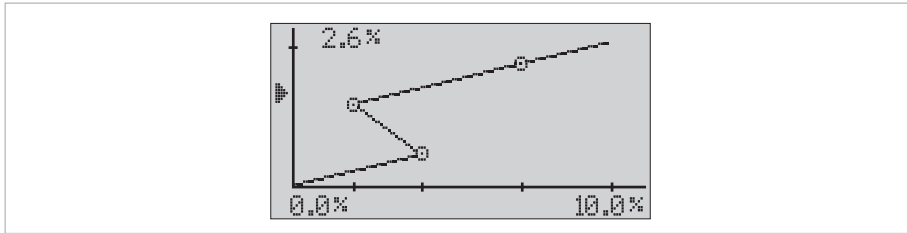

Figure 5-3: Incorrect calibration

In the above figure the curve goes backwards because two samples have been exchanged when entering the lab results. A higher Y-value must have a higher X-value. The curve must continue upwards and to the right.

5.3.4 Automatic adjustment of the calibration

The function **Adjust** in the **Calibrate** menu is used to automatically adjust the calibration in an easy way using an offset value. When a sample is taken to be analysed by lab, the converter stores the reading. When the sample has been analysed, the result is keyed in to the converter. The converter will compare it to the stored reading and calculate a new setting for the sample value.

Automatic adjustment (offset) only works for single point calibrations and is primarily intended as an easy way to get started with a new sensor. Once the automatic adjustment is done and the sensor gives a sensible reading, we recommend using a statistical adjustment to get a higher accuracy over time (see next section).



CAUTION!

Even though the sensors have daylight-filters, they are sensitive to the infrared parts of the sunlight. Always cover the sensor and the bucket before calibration.



Running an automatic adjustment

- Fill a bucket with a sample of the liquid you intend to measure.
- Submerge the sensor into the liquid.
- Select the sensor to be calibrated in the menu by using \uparrow or \downarrow .
- Press \leftarrow for approximately 5 seconds to enter the sensor menu.
- Select **Calibrate > Adjust** and then **Store** using \uparrow and \downarrow .
- Select **Take sample** and stir the sample in the bucket until the measuring is finished.
- Take the bucket to the lab for analysis. Note the concentration of the sample determined at the lab.
- Select **Calibrate > Adjust** and then **Lab** using \uparrow and \downarrow .
- Press \leftarrow .
- Press \leftarrow to use the stored reading or \uparrow to key in a value.
- Key in the result of the lab analysis, then press \leftarrow .
- \odot MAC 080 will show the current value and the suggested new value for "Sample 1".
- Acknowledge the change by pressing \leftarrow or abort using \uparrow or \downarrow .

5.3.5 Statistic adjustment

Statistic adjustment of the lab sample value is a much better way to good measurement than frequent calibration. This is done comparing the lab results with the instrument reading over time. If a systematic discrepancy is detected, change accordingly the value of the lab sample used in the converter by using the **Adjust** function in the calibration menu.

If, for example, several lab results for a period of time in average show 5 % more than the instrument, the sample value in the converter shall be increased by 5% of its value. E.g. if the sample value is 10000 mg/l, it shall be changed to 10500 mg/l.

Using the statistic method will increase the accuracy and reliability of the measurement as time passes while new calibrations will start from scratch. An Excel sheet to help doing statistical adjustment of the calibration can be obtained from the manufacturer.



Running a statistic adjustment

- Select the sensor to be calibrated in the menu by using ↑ or ↓.
- Press ← for approximately 5 seconds to enter the sensor menu.
- Select **Calibrate > Adjust** and then **Lab** using ↑ and ↓.
- Press ←.
- Press ↑ to key in a value.
- Key in the result of the statistical calculation, then press ←.
- ➡ The converter will show current and suggested new value for "Sample 1".
- Acknowledge the change by pressing ← or abort using ↑ or ↓.

5.3.6 Zero calibration



CAUTION!

Even though the sensors have daylight-filters, they are sensitive to the infrared parts of the sunlight. Always cover the sensor and the bucket before calibration.

The sensor is zero-calibrated at the factory and does not often need to be zero-calibrated. Before doing a zero calibration, always check that it is really needed. Make sure the lenses are clean, and use clean de-aerated water to check the sensor reading. Tap water is best de-aerated by leaving the water in an open bucket for at least two hours.



Running a zero calibration

- Remove the sensor from the process and clean the sensor head.
- Dip the sensor in a bucket of clean water.
- Select the sensor to be calibrated in the menu by using ↑ or ↓.
- Press ← for approximately 5 seconds to enter the sensor menu.
- Select **Calibrate > Take sample** and then press ←.
- Select **Zero** by using ↑ or ↓ and then press ←.
- To acknowledge that you really want to change the zero calibration, select **Yes** and then press ←.
- ➡ The converter will ask you to put the sensor in clean water.
 - Submerge the sensor head into the clean water and cover it from direct sunlight.
 - Press ←.
 - Wait for the zero calibration to finish. It will take approximately 30 seconds before the unit returns to the menu.



INFORMATION!

Detailed procedures for navigating the converter software can be found in the converter manual.

5.3.7 Calibration with samples



CAUTION!

Even though the sensors have daylight-filters, they are sensitive to the infrared parts of the sunlight. Always cover the sensor and the bucket before calibration.



Calibration with sample in a bucket

- Fill a bucket with a sample of the liquid you intend to measure.
- Submerge the sensor into the liquid.
- Select the sensor to be calibrated in the menu by using ↑ or ↓.
- Press ← for approximately five seconds to enter the sensor menu.
- Select **Calibrate > Take sample** and then **#1** using ↑ and ↓.
- Press ← and stir the sample in the bucket until the calibration is finished. It will take approximately 30 seconds.
- Take the bucket to the lab for analysis. Note the concentration of the sample determined at the lab.
- Enter sample #1 concentration by selecting **Calibrate > Sample #1** in the calibration menu.
- Press ←.
- Use ↑ and ↓ to change the values and ← to go to the next digit. Some special applications may need additional sample points. Do not enter samples that are identical in concentration or less than 10% from initial values.



Calibration of submersible sensor in a basin or channel

- Calibration can be done without the use of a bucket. Make sure that the sensor is at least 30 cm / 11.8" below the lowest liquid level.
- Follow the steps 3 to 5 of the above procedure "Calibration with a sample bucket".
- While the OAS 2000 is calibrating, grab a sample of the liquid with a dip bucket. Make sure to grab a sufficiently large sample volume for low solids applications.
- Take the sample to the lab for analysis. Note the concentration of the sample determined at the lab.
- Follow the steps 8 to 10 of the above procedure "Calibration with a sample bucket".



Calibration of inline sensor in a pipe

- Inline sensors are easiest calibrated if the pipe has a sample outlet.
- Follow the steps 3 to 5 of the above procedure "Calibration with a sample bucket".
- While the OAS 2000 is calibrating, open the sample valve and fill a bucket with process liquid.
- Take the sample to the lab for analysis. Note the concentration of the sample determined at the lab.
- Follow the steps 8 to 10 of the above procedure "Calibration with a sample bucket".

5.4 Scaling

The menu **Scale / Alarm** (see converter manual) allows the user to set the high and low boundaries for a 4...20 mA output signal. In addition, this menu allows the user to set high and low alarm values to switch a relay when solids have reached critical points.

Max	Sets the 20 mA point output.
Min	Sets the 4 mA point output (may be negative for special applications).
Hi-Alarm	Sets the high alarm set point (the value zero inactivates the alarm).
Low-Alarm	Sets the low alarm set point (the value zero inactivates the alarm).

6.1 Cleaning the flushing nozzle

If the flushing nozzle becomes plugged, it can usually be cleaned by backflushing it with clean water.



Cleaning the flushing nozzle on submersible sensors

- Before attempting to backflush, close the valve of the flush water source.
- Disconnect the sensor flushing hose from the solenoid valve.
- Place a 12 mm / 0.47" hose over the flush nozzle and carefully open the water valve.
- ➔ The pressure should clear the line of solids. If backflushing does not work initially, try cleaning the three flushing nozzles with a needle. Try backflushing the nozzles again as described above until clean water comes out at the solenoid valve end of the hose.



INFORMATION!

The nozzle of an inline sensor usually does not need to be cleaned. The nozzle works as a check valve to avoid that process liquid is pressed up the flushing hose. It consists of a rubber membrane held in place by a steel bracket.



Plugging the nozzle if flushing is not used

- Plug the nozzle by removing the membrane and the steel bracket, which is attached with two screws to the sensor head.
- Fit a spotfaced M5x8 screw with soft thread retainer in the hole.

6.2 Spare parts availability

The manufacturer adheres to the basic principle that functionally adequate spare parts for each device or each important accessory part will be kept available for a period of 3 years after delivery of the last production run for the device.

This regulation only applies to spare parts which are under normal operating conditions subjects to wear and tear.

6.3 Spare parts and accessories

Order number	Designation
XGA S 06010	OAS 2000 inline connection valve
XGA S 06020	OAS 2000 inline but weld end R 1½"
XGA S 06030	OAS 2000 inline 1/12" NPT nipple
XGA S 06040	Sealing kit for OAS 2000 inline version
XGA W 08010	Signal cable extension for OPTISENS 2000 sensor (10 m / 33 ft)
XGA W 08020	Signal cable extension for OPTISENS 2000 sensor (30 m / 98.4 ft)

6.4 Availability of services

The manufacturer offers a range of services to support the customer after expiration of the warranty. These include repair, technical support and training.

**INFORMATION!**

For more precise information, please contact your local representative.

6.5 Returning the device to the manufacturer

6.5.1 General information

This device has been carefully manufactured and tested. If installed and operated in accordance with these operating instructions, it will rarely present any problems.

**CAUTION!**

Should you nevertheless need to return a device for inspection or repair, please pay strict attention to the following points:

- *Due to statutory regulations on environmental protection and safeguarding the health and safety of our personnel, manufacturer may only handle, test and repair returned devices that have been in contact with products without risk to personnel and environment.*
- *This means that the manufacturer can only service this device if it is accompanied by the following certificate (see next section) confirming that the device is safe to handle.*

**CAUTION!**

If the device has been operated with toxic, caustic, flammable or water-endangering products, you are kindly requested:

- *to check and ensure, if necessary by rinsing or neutralizing, that all cavities are free from such dangerous substances,*
- *to enclose a certificate with the device confirming that is safe to handle and stating the product used.*

6.5.2 Form (for copying) to accompany a returned device

Company:		Address:	
Department:		Name:	
Tel. no.:		Fax no.:	
Manufacturer's order no. or serial no.:			
The device has been operated with the following medium:			
This medium is:	water-hazardous		
	toxic		
	caustic		
	flammable		
	We checked that all cavities in the device are free from such substances.		
	We have flushed out and neutralized all cavities in the device.		
We hereby confirm that there is no risk to persons or the environment through any residual media contained in the device when it is returned.			
Date:		Signature:	
Stamp:			

6.6 Disposal



CAUTION!

Disposal must be carried out in accordance with legislation applicable in your country.

7.1 Measuring principle

The sensor measures transmitted light through the liquid. The measuring principle is based on the suspended particles ability to absorb and reflect NIR (Near Infrared) light. The light source is a light emitting diode that pulses and emits monochromatic light with a wavelength of 880 nm. The detected measuring signal is inversely logarithmical proportional to the concentration of suspended solids. Signal treatment or linearisation is done within the converter.

In addition, the temperature is measured to be used for temperature compensation of the measured value. It can be read in the converter and used as secondary value when a sensor is configured to use both analog outputs.



INFORMATION!

The built-in temperature measurement is not a precision measurement, but shall be seen as an indication.

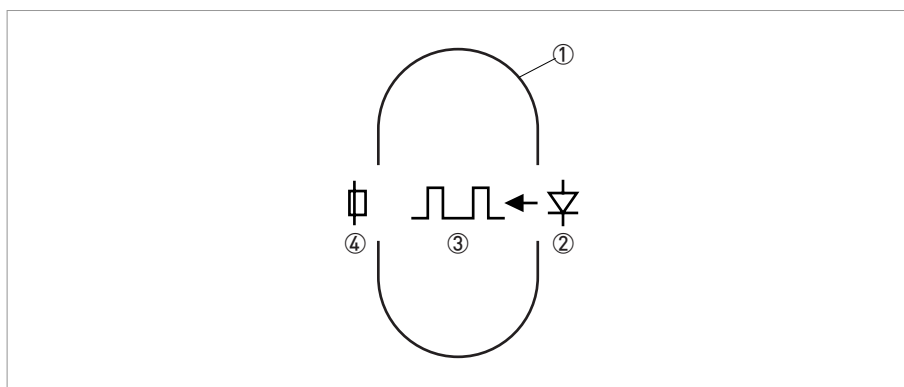

Figure 7-1: Cross-section of measuring gap

- ① Measuring gap
- ② Light source (NIR-LED)
- ③ Monochromatic light beam
- ④ Detector

7.2 Technical data



INFORMATION!

- The following data is provided for general applications. If you require data that is more relevant to your specific application, please contact us or your local representative.
- Additional information (certificates, special tools, software,...) and complete product documentation can be downloaded free of charge from the website (Download Center).

	Submersible version	Inline version
--	---------------------	----------------

Measuring system

Measuring principle	Transmitted light absorption principle, pulsed NIR 880 nm, with reference measurement, temperature-compensated.	
	Reflection and absorption of light on suspended solids and sludge particles. The light passes the measured particles between the emitter and the detector in a straight line.	
Application range	Continuous measurement of suspended solids in waste water and sludge (e.g. in aeration basins).	Continuous measurement of suspended solids in pump lines for waste water and sludge (e.g. in pump lines for return sludge).
Measured value	Suspended solids concentration	

Design

Modular construction		
	A typical measuring system consists of: <ul style="list-style-type: none"> • MAC 080 multiparameter converter • 1 (or up to 4) OPTISENS 2000 sensors • Solenoid valves to control spray cleaning 	
	Assemblies for submersion or side wall installation.	Ball valve assembly for inline installation.
Measuring range	0...20000 mg/l (ppm), min. 0...100 mg/l (depending on the sludge type)	0...5% suspended solids, min. 0...100 mg/l (depending on the sludge type)
Flushing	Flushing using clean water or compressed air.	
	Pressure: 6 bar / 87 psi	Pressure: 2 bar / 29 psi above process pressure, max. 10 bar / 145 psi
	Solenoid valve: available in 220 V and 117 V versions, up to 2 sensors can be operated on a single valve.	
	Flush hose: ¼" external diameter, PE, standard length: 10 m / 32.8 ft	

Measuring accuracy

Reference conditions	Medium: water
	Temperature: +25°C / +77°F
	Pressure: 1 barg / 14.5 psig
Maximum measuring error	Typical $\pm 2\%$ of selected range, max. $\pm 5\%$ of selected range.
	Temperature: $\pm 0.5^\circ\text{C}$ / 0.5°F
Display resolution (in combination with MAC 080)	1 mg/l, extended mode: 0.1 mg/l
	Temperature: 0.1°C / 0.1°F
Calibration	Pre-calibrated in the factory, calibration on site: software-supported single or multipoint calibration using reference samples.

Operating conditions

Temperature	Process temperature = ambient temperature	
	0...+60°C / 32...140°F	
Process pressure	Ambient	Max. 6 bar / 87 psi with automatic cleaning
		Max. 10 bar / 145 psi without automatic cleaning (special version)
Max. immersion depth	10 m / 32.8 ft	N/A
Protection category	IP68 (Nema 6)	

Installation conditions

AAS 2000 + MAA 2000 fibreglass telescopic rod for submersible installations	Installation on the handrail with up to 4 m length-adjustable, oscillating fibreglass assembly.	N/A
	Handrail mounting for: <ul style="list-style-type: none"> • Round handrails: d = 32...50 mm / 1.3...2" • Square cross-sections: 28...42 mm / 1.1...1.7" 	
AAS 2000 + MAA 2000 slide rail mounting for side wall installations	Installation on side walls of channels and basins using slide rails for simple sensor removal.	N/A
OAS 2000 inline version	N/A	Pipe installation using a butt weld end for holes of 48.5 mm / 1.9" diameter (standard scope of delivery) or with an optional 1½" NPT nipple, on which a ball valve is installed to fit the sensor. Min. pipe diameter: 80 mm / 3.1".
Dimensions and weights	For detailed information see chapter "Dimensions and weights".	
Process connection	Open basins and channels	1½" ball valve for inline installation

Materials

Enclosure	316 SS
NIR diode	GAS diode, 880 nm wavelength, pulsed
Connection cable to converter	Insulation: Hytrel (5-pin M12 connector, fixed cable, shielded, 10 m / 32.8 ft)
Flush hose	PE

Approvals and certifications

CE sign	This device fulfils the statutory requirements of the EC directives. The manufacturer certifies successful testing of the product by applying the CE mark.
Electromagnetic compatibility	Interference emission to EN 61000-6-4:2001; immunity to EN 61000-6-2:2001.
Low voltage directive	Safety requirements for electrical equipment for measurement, control and laboratory use in accordance with EN 61010-1:2001.

7.3 Dimensions and weight

Figure 7-2: Submersible version

	Dimensions [mm]	Dimensions [inches]	Weight	
			[kg]	[lbs]
a	Ø66	Ø2.6	1.6	3.5
b	20	0.8		
c	227	8.9		
d	255	10.0		

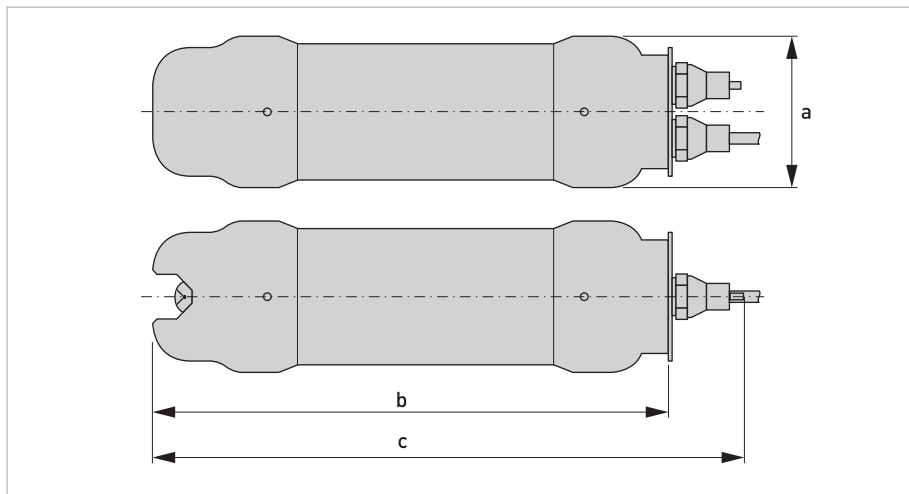
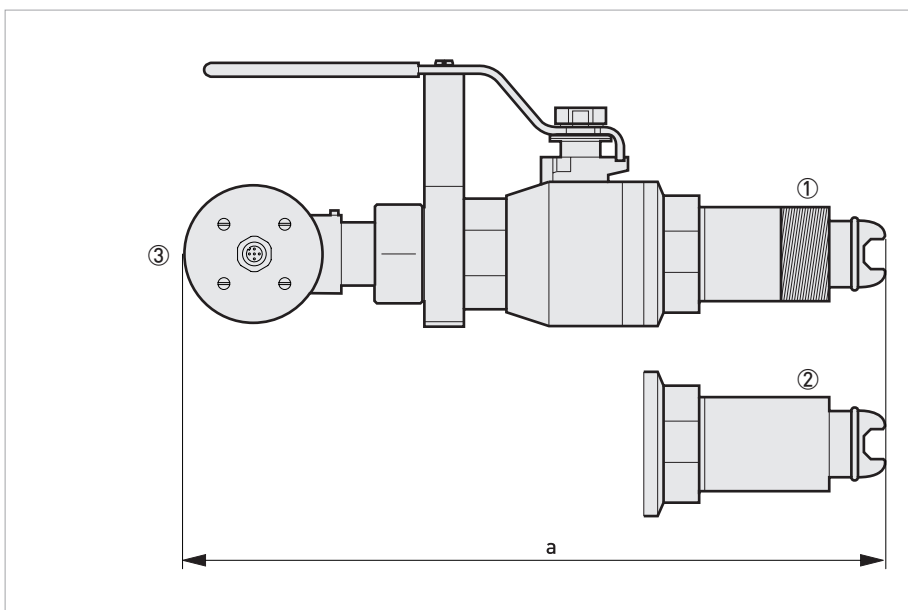

Figure 7-3: In-line version

- ① 1½" NPT
- ② Welding end
- ③ Min. 283 mm / 11.1" (de)installation spacing

	Dimension [mm]	Dimension [inches]	Weight	
			[kg]	[lbs]
a	368	14.5	4.6	10.1

8.1 Setup information form

This form can be used to document the setup of the sensor.

Sensor type:	
Position / Tag:	
In the System submenu of the sensor menu the following information can be collected:	
Serial:	
SoftW:	
In the Settings submenu of the sensor menu the following parameters can be set:	
I-time:	
Unit:	
Analog:	
Second:	
In the Cleaning submenu of the sensor menu the following parameters can be set:	
Cleaner:	
Cleaning interval:	
Cleaning length:	
Cleaning freeze:	
Cleaning relay:	
In the Scale / Alarm submenu of the sensor menu the following parameters can be set:	
Max:	
Min:	
High alarm:	
Low alarm:	
Alarm relay:	
Leave the menu by pressing ↑ and ← simultaneously.	

8.2 Support information form

Company:		Name:	
Phone:		E-mail:	
Sensor type:		Position / tag:	
First go to the converter menu by pressing ↑ and ← simultaneously for five seconds. Then select System and press ←. Write down the following information.			
Version:			
Serial:			
Box temp:			
Leave the converter menu by pressing ↑ and ← simultaneously. Use ↑ and ↓ to select the sensor in the main display. Go to the sensor menu by pressing ← for 5 seconds. Then select System and press ←. Write down the following information.			
Type:		SoftW:	
Serial:		Temp:	
Select System > Samples and press ←. Write down the following information.			
SA 0:			
SA 1:		Cons 1:	
SA 2:		Cons 2:	
SA 3:		Cons 3:	
SA 4:		Cons 4:	
SA 5:		Cons 5:	
Select System > Info and press ←. Write down the following information.			
MS:		Con:	
SA0:		SA1:	
Cons 1:		Ch1a:	
Ch1:		Intensity:	
Zero Int:		I-offset:	
Leave the menu by pressing ↑ and ← simultaneously.			





KROHNE product overview

- Electromagnetic flowmeters
- Variable area flowmeters
- Ultrasonic flowmeters
- Mass flowmeters
- Vortex flowmeters
- Flow controllers
- Level meters
- Temperature meters
- Pressure meters
- Analysis products
- Measuring systems for the oil and gas industry
- Measuring systems for sea-going tankers

Head Office KROHNE Messtechnik GmbH
Ludwig-Krohne-Str. 5
D-47058 Duisburg (Germany)
Tel.: +49 (0)203 301 0
Fax: +49 (0)203 301 10389
info@krohne.de

The current list of all KROHNE contacts and addresses can be found at:
www.krohne.com

KROHNE