

07/2008

Installation and Operating Instructions

OPTISENS PAC 050

Measuring and control device
for pH and ORP measurements



Content

0.	Introduction	4
0.1	General	4
0.2	Legal matters	4
0.3	Safety	5
0.3.1	Documentation symbols.....	5
0.4	Features	6
0.4.1	Device	6
0.4.2	Controller.....	6
0.4.3	Connections	6
1.	Mechanical installation	7
1.1	Installation of panel-mounting converters	7
1.2	Installation of wall-mounting converters.....	8
2.	Electrical connection	9
2.1	Connection diagram panel-mounting converter	10
2.2	Connection diagram wall-mounting enclosure	11
3.	Operation of the device	12
3.1	How to adjust parameters	12
3.1.1	Selection between alternatives	12
3.1.2	Adjustment of numerical parameters	13
3.2	Menu Overview	13
3.2.1	Main menu and basic settings	13
3.3	Password and language	14
3.3.1	Enter password	14
3.3.2	Language	14
4.	Adjustments for the measurement	14
4.1.1	Measurement	15
4.2	pH measurement.....	15
4.3	ORP measurement	15
4.4	Calibration	16
4.4.1	Calibration procedure.....	16
4.4.2	Buffers.....	16
4.5	Temperature compensation	17
4.5.1	Calibration of the temperature measurement	17
5.	Adjustments of the controller	17
5.1	ON/OFF controller.....	18
5.2	P / PI controller as impulse-frequency controller	19
5.3	P / PI controller as pulse-pause controller	19
5.4	Activation and deactivation of the controller	20
5.5	Turn-on delay	20
5.6	External controller stop	20
5.7	Manual operation of the relays.....	21
5.8	Limit values	22
5.8.1	Turn-on delay.....	22
5.9	Dosage check	22
6.	Alarm	23
6.1	Error messages.....	24
7.	Output	24
7.1	Current output	25
7.2	Serial interface RS485 (option).....	25
8.	Operation and maintenance	25
8.1	Maintenance of the device	25
8.2	Display contrast.....	25
8.3	Exchange fuse	25
8.4	Cleaning	25
8.5	Maintenance of the pH or ORP measurement.....	26
8.6	Disposal	26
8.7	Service	26
8.7.1	Product info	26
8.7.2	Analog inputs	26
8.7.3	Erase settings (reset).....	26

9.	Technical data	27
9.1	Technical data.....	27
9.2	Dimensions	28
9.2.1	Panel-mounting enclosure	28
9.2.2	Wall-mounting enclosure	28
10.	Device return form	29
11.	Customer settings - for reference	30

0. Introduction

0.1 General

This manual applies to the following devices:

Device and type	Revision date
AC 050 pH/ORP P	06 / 05
AC 050 pH/ORP W	06 / 05

It contains technical information for the installation, start-up and maintenance. If you have any questions not included in this manual please contact your supplier or the official representative of KROHNE Water Solutions in your country.

0.2 Legal matters

Authorized personnel

Installation, connection, adjustment, start-up, and maintenance of the device are carried out by authorized personnel with adequate qualification.

Liability

Responsibility as to suitability and intended use of these devices rests solely with the user. Improper installation and operation may lead to loss of warranty. In addition, KROHNE Group's Standard General Conditions of Sale and Delivery, found on the back of the invoice and forming the basis of the purchasing contract, are applicable.

General limitation on liability

Unless otherwise expressly set forth in the Standard Terms and Conditions of Sale and Delivery, the Seller is only liable for damages, whatever their legal basis is, in case they are based on willful action or gross negligence. This limitation on liability does not apply in the event the Buyer raises claims relating to personal injury or damages to property according to the product liability law based on a defect of the delivered goods.

Any advice given by the Seller, in particular regarding the application of the delivered goods, shall only commit the Seller if given or confirmed in writing.

Returning the device

If you need to return the level gauge to the manufacturer or supplier, please read to the instructions and complete the form given in the appendix.

Warranty

Please consult KROHNE Water Solutions General Terms and Conditions for information on guarantee and liability.

0.3 Safety

Please check for damages immediately after receiving the devices and report any damages within 24 hours to the delivering company. Never work with a damaged device.

Keep this manual at a safe place where you can always look up the safety instructions and the information on handling and usage.

This device was designed and built according to the safety measurements for electronic devices and has left our company in perfect working condition. To preserve this condition and to ensure safe usage follow all instructions carefully and pay special attention to all warnings issued in this manual. If the device is visibly damaged or has been stored inappropriately or if there are any doubts concerning safe usage, shut it down and make sure it cannot be restarted by accident.

0.3.1 Documentation symbols

A set of symbols is used to give warnings or information relevant to particular applications. These are defined below:



Caution / Attention

Information that, if not followed, may lead to actions resulting in incorrect functioning of the device.



Warning

Information that, if not followed, may lead to actions resulting in measurement error, personal injury and/or damage to the device.

NOTE

Is used to highlight interesting details.

0.4 Features

0.4.1 Device

Measuring ranges	0.00...14.00 pH -1500...+1500 mV
Temperature measuring ranges	-30.0...+140.0°C
Display	measured value with dimension temperature with dimension status display sensor, calibration, controller & alarm
Temperature compensation	manually or automatically with Pt100 or Pt1000
Calibration	automatic recognition of the calibration solutions in arbitrary order

0.4.2 Controller

Set points	2 set points with adjustable direction
Controller types	ON/OFF controller with hysteresis P controller as Pulse-Pause-, Impulse-Frequency- or steady controller PI controller as Pulse-Pause-, Impulse-Frequency- or steady controller
Hysteresis	0.00...14.00 pH or 0...1500 mV
P range X_P	0.00...14.00 pH or 0...1500 mV
Integral time T_N	0...2000 s
Least pulse	0.1...9.9 s
Pulse+ pause time	02...99 s
Impulse frequency	00...72 equiv. to 0...7200 pulses/h
Turn-on delay	0...200 s
Alarm function	min. and max. limit and onset delay, power failure alarm, impulse or permanent signal
Dosage control	0...2000 s

0.4.3 Connections

Relays	3 potential-free contacts (2x controller, 1x alarm) 6 A, 250 V, max. 550 VA
Analog output	0/4...20 mA galvanically isolated max. burden 500 Ohm
Analog inputs	1 measuring input for pH or ORP 1 measuring input for Pt100 or Pt1000
Digital input	external controller stop or lack-of-water indication
Serial interface (Option)	RS 485, Baud rate 9600, data format 8 Bit, 1 start and 1 stop bit, no parity

1. Mechanical installation

On chapter 9.2 you will find detailed instructions for the installation.

For panel-type meters you have to prepare an opening of 92 x 92 mm / 3.6" x 3.6". Install the device and fix it with the two mounting clips which were part of the delivery.

You can install devices in wall-mounting enclosures either by hanging them upon the center slot or by sliding the slot under a screw, which is an alternative for limited space. Either way you have to fix it additionally with two screws.

Install the device in a place where it is not put under mechanical or chemical strain!



ATTENTION

Mind the protection class:

- Panel mounting version: IP 54 (front), IP 30 (Housing)
- Wall mounting version: IP 65 (closed terminal cover)

1.1 Installation of panel-mounting converters

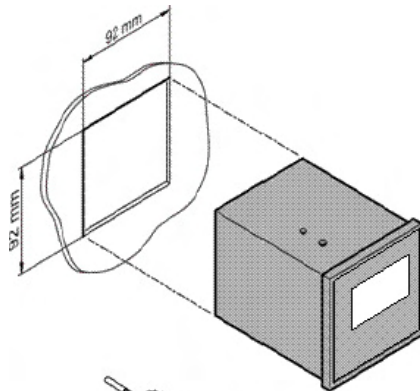

Prepare an opening of 92 x 92 mm / 3.6" x 3.6".

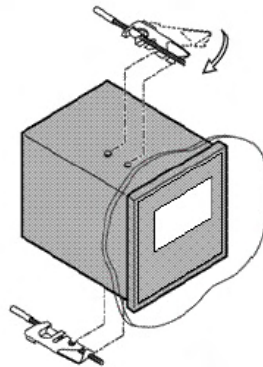

Install the device from the front side and fix it with the two mounting clips which were part of the delivery.

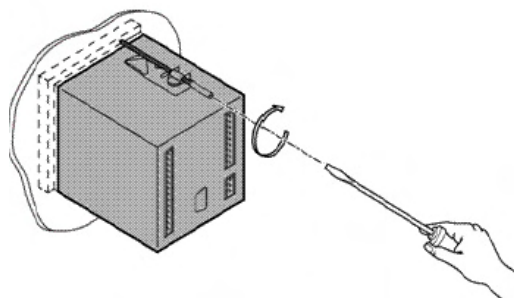

Screw tight until the device is fixed perfectly.

1.2 Installation of wall-mounting converters

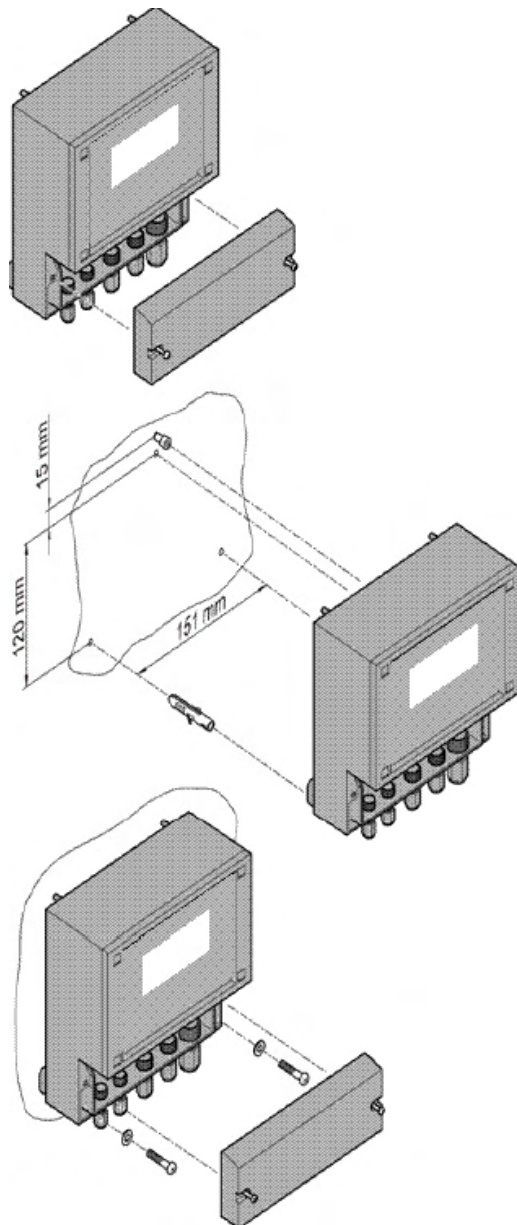

Unscrew the terminal cover.

Drill three holes (max. M5) according to the drawing. Mind that there are two ways for installation:

(1) You can hang the device upon the upper screw. In that case drill the upper hole 120mm / 4.7" above the lower two.

(2) Or you can slip the fixture on the back of the device under the upper screw. In that case the upper hole has to be another 15mm / 0.6" higher.

Insert the upper screw and make sure to leave at least 3 mm between wall and screw head for the fixture.

Mount the device and fix it with the two lower screws. Close the terminal cover or start with the connections.

2. Electrical connection

You will find a detailed connection diagram on the following pages.

Before connecting the power supply check the information on the nameplate of the device!

Input, output and control lines must be installed separate from each other and separate from power lines!



ATTENTION

For inputs and outputs use screened lines and connect the screen on one side only.

The pH measurement is interference-sensitive. Use a special screened cable and over long distances or in humid atmosphere additionally an impedance converter.

When using the relays, mind that with inductive loads, interference must be suppressed. If that is not possible, the relay must be protected at the terminal block in the converter by a resistance-capacitance filter or, in case of direct current, by a free-wheeling diode.

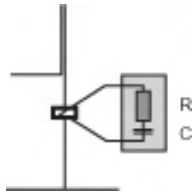

Current up to	Capacitor C	Resistance R
60 mA	10 nF 260 V	390 Ohm 2 Watt
70 mA	47 nF 260 V	22 Ohm 2 Watt
150 mA	100 nF 260 V	47 Ohm 2 Watt
1.0 A	220 nF 260 V	47 Ohm 2 Watt

2.1 Connection diagram panel-mounting converter

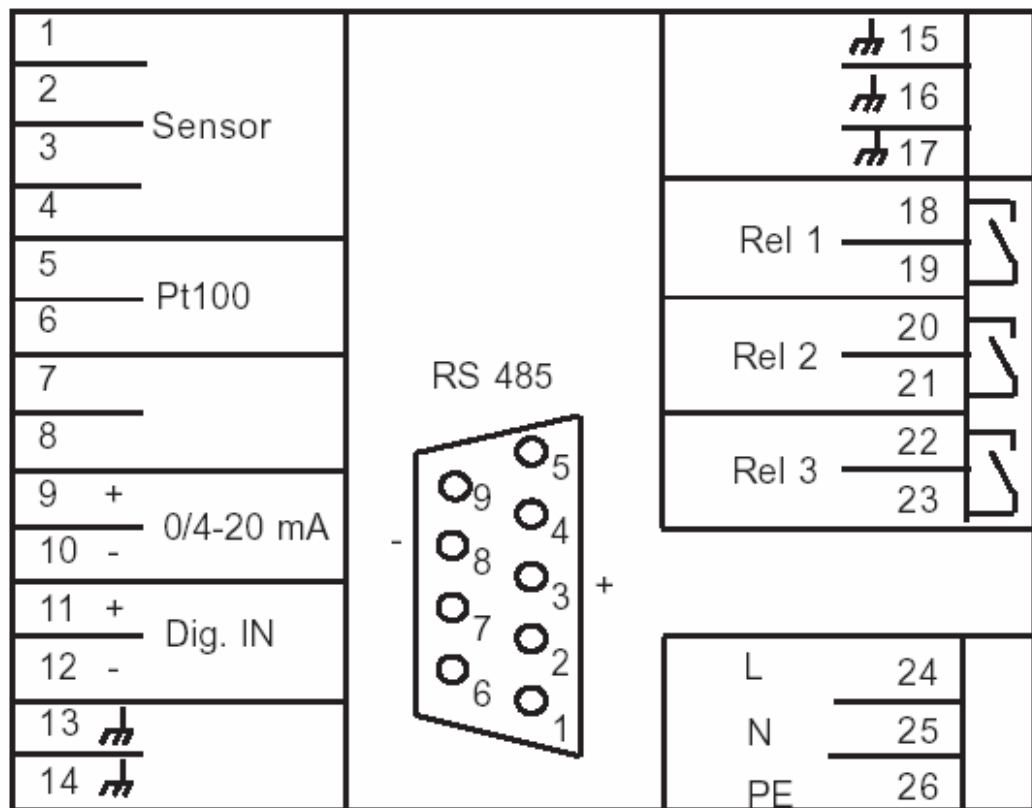

Connection	Terminals	Notes
pH electrode	1 - 2	1 = reference electrode = screen 2 = measuring electrode = core
ORP electrode	1 - 2	1 = measuring electrode = core 2 = reference electrode = screen
Impedance converter	1 - 4	Measurement = brown & white 1 = brown, 2 = white Supplied voltage = yellow & green 3 = yellow = -6V, 4 = green = +6V
Pt 100	5 + 6	
Analog output	9 + 10	9 = +, 10 = - max. burden 500 Ohm
Digital input	11 + 12	11 = +, 12 = - External controller stop or lack of water ind.
Relay 1	14 + 15	
Relay 2	16 + 17	
Relay 3	18 + 19	Alarm relay
Power supply	21+ 22+23	check information given on instrument label
RS485 (option)	Sub-D Sub-D 4/7	3 = +, 8 = - bridged = terminating impedance activated

2.2 Connection diagram wall-mounting enclosure

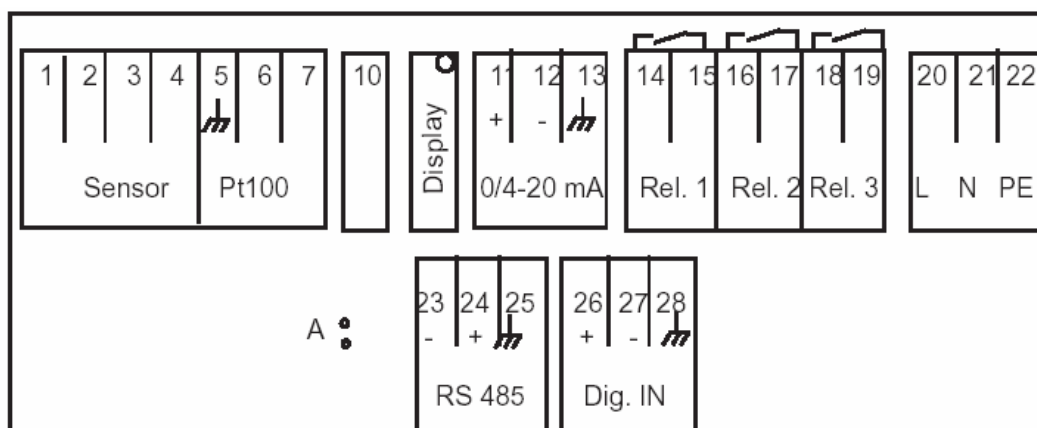

Connection	Terminals	Notes
pH electrode	1 - 2	1 = reference electrode = screen 2 = measuring electrode = core
ORP electrode	1 - 2	1 = measuring electrode = core 2 = reference electrode = screen
Impedance converter	1 - 4	Measurement = brown & white 1 = brown, 2 = white Supplied voltage, yellow & green 3 = yellow = -6V, 4 = green = +6V
Pt 100	6 - 7	
Display contrast	Display	Potentiometer to adjust the display contrast
Analog output	11 + 12	11 = +, 12 = - max. burden 500 Ohm
Relay 1	14 + 15	
Relay 2	16 + 17	
Relay 3	18 + 19	Alarm relay
Power supply	20+21+22	check information given on instrument label
RS 485 (option)	23 + 24	23 = 1, 24 = +
Digital input	26 + 27	26 = +, 27 = -, external controller stop or lack-of water indication

3. Operation of the device

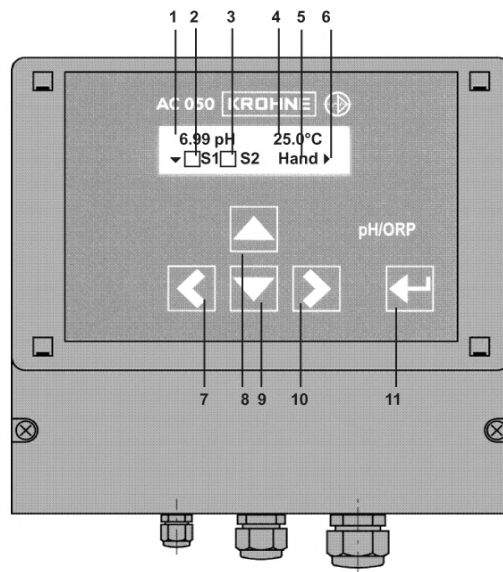

- 1 Measured value
- 2 Status relay 1
- 3 Status relay 2
- relay OFF
- relay ON
- 4 Temperature
- 5 Controller
- AUTO: controller ON
- MAN : controller OFF
- (manual operation of the relays)
- 6 Orientation aids
- 7 Key left (◀)
- 8 Key up (▲)
- 9 Key down (▼)
- 10 Key right (▶)
- 11 Key "Enter"

When turned on the device shows the measured values of conductivity and temperature together with the controller mode (Man) and the status of the relays S1 and S2 (both OFF).

With five membrane keys you can move within the menu:

- With key ▼ you enter the main menu.
- With keys ▲ and ▼ you move up and down in the menu.
- With key ▶ you address a menu or parameter.
- With key ◀ you leave a menu without storing
- With key "Enter", changes are stored.

For your convenience triangles in the display indicate the directions you can take from your position in the menu.

3.1 How to adjust parameters

Temp. comp.
▶ Manual.

1) When you address a parameter the actual setting is displayed.

Temp. comp.
▶ Auto

2) Switch to the next alternative setting with key ▶ .

Temp. comp.
▶ Manual.

3) When you have come to the last alternative, pressing the key once more will bring you back to the start.

3.1.1 Selection between alternatives

For many parameters you have the choice between two or more alternatives, for e. g. between manual and automatic temperature compensation. For these parameters you need only key ▶ . Switch from one alternative to the next until you either come back to where you started or until you reach the alternative you were looking for.

With these parameters any changes are immediately valid - there is no need to store the change.

3.1.2 Adjustment of numerical parameters

Numerical parameters can only be altered when a double arrow is visible behind the number. This double arrow appears when you address the parameter with key ▶ .

Adjust the parameter with keys ▲ and ▼ . A short pressure on the key changes the last decimal by 1. If you keep the key pressed, the value will continue changing until the pressure is released.

Store the changes with key „Enter“. The double triangle disappears.

Enter password
▶ 058

1) Address the parameter with key ▶ .

Enter password
◀ 058 ↓

2) A double arrow appears behind the number indicating that the number can be changed now with keys ▲ and ▼ .

Enter password
▶ 062

3) Store the new value with key „Enter“. The double arrow disappears - the new value is stored.

3.2 Menu Overview

6.98 pH 25.0°C
 S1 S2 Auto

Display of the measured values (example)



Press key ▼ to enter the main menu.

Main menu

Calibrate
Temp. comp.
Enter password
Set points
Limit values
Basic settings
Service

Calibration function (only for pH measurements)

Temperature compensation (only for pH measurements)

Password function

Controller settings - set points, P ranges, I functions

Alarm function

Basic settings

▶ Cal. Pt 100
Buffers used
Contr. Settings
Turn-on delay
Analog outputs
Language
Bus address
pH/ORP

All parameters which are set just once at the beginning can be found in the menu "basic settings"

3.2.1 Main menu and basic settings

The parameters are sorted into two menus: In the main menu you will find all functions which are used regularly. The menu basic settings contain all parameters which are set just once during start-up.

On the following pages you will find information on how to adjust parameters and which parameters you need for which application.

The information follows the following scheme:

- 1) General adjustments: password and language
- 2) Adjustments for measurement: calibration and temperature compensation for pH or selection of ORP measurement
- 3) Adjustments of the controller: selection of the controller version and corresponding parameters
- 4) Adjustments to read out data: analog, digitally and/or as alarm

3.3 Password and language

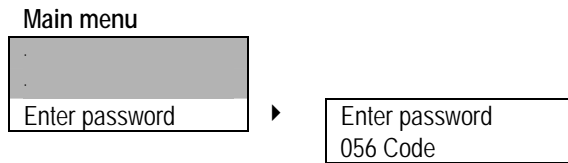

3.3.1 Enter password

To get access to the various parameters you have to enter the correct password:

- Code 11 gives access to the parameters „calibration“, „temperature compensation“, and „set points“.
- Code 86 gives access to all parameters and functions.

With any other number it is impossible to select, view or change any parameter.

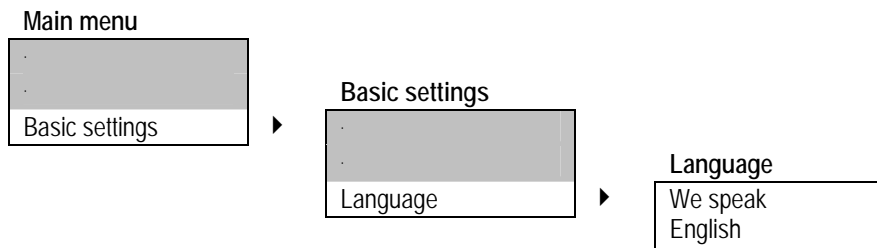

3.3.2 Language

For the communication with the device you can choose from a variety of languages.

Since choosing a language is part of the basic settings, it requires code 86. If a different code is set, you will be asked to enter the correct password.

4. Adjustments for the measurement

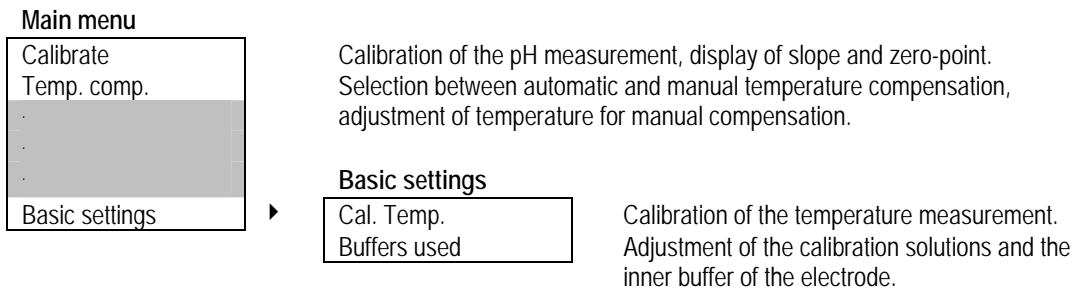

The instruments can be used for pH or ORP measurements.

4.1.1 Measurement

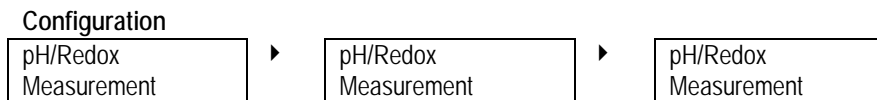

Displayed is always the actual active configuration. With key ▶ you can switch from pH measurement to ORP measurement. Press the key again to go back to the original setting.

4.2 pH measurement

pH measurement requires a calibration.

By means of calibration the electrode's characteristics are determined and stored. The procedure is a subsequent measurement of two solutions with a known pH. The pH values of the buffers used as calibration solutions are stored in the menu basic settings.

You have to adjust the calibration data only if you want to use special calibration solutions or electrodes with a special buffer solution.

The electrode's slope is influenced by temperature. This influence can be compensated by manual or automatic compensation. Manual compensation means that the temperature is entered manually. Automatic compensation requires measuring the temperature with a Pt100 or Pt1000.

4.3 ORP measurement

ORP measurements do not require calibration or temperature compensation. Therefore the parameters „calibration“ and „temperature compensation“ do not appear in the menu if ORP measurement has been selected.

NOTE

The ORP measurement needs no calibration and no compensation for temperature effects. Therefore these parameters do not appear in the menu if ORP measurement is selected.

4.4 Calibration

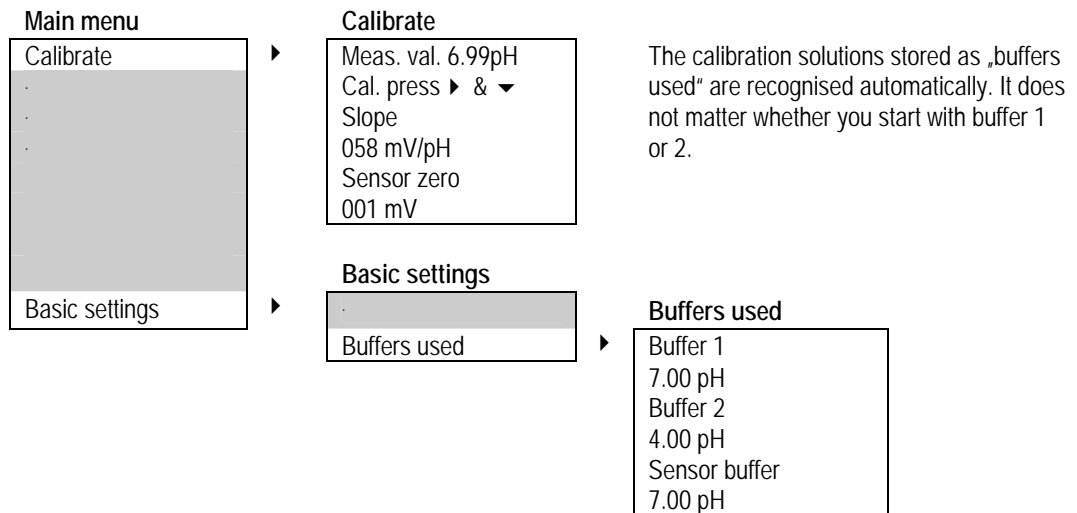

4.4.1 Calibration procedure

- 1) Switch the controller OFF and select manual temperature compensation. Enter the temperature of the calibration solutions.
- 2) Immerse the electrode in one of the calibration solutions. Wait until the measured value is stable, then calibrate by pressing keys ◀ and - while still applying pressure - additionally key ▼ . The pH of the calibration solution is now displayed as measured value.
- 3) Rinse the electrode and repeat step 2 with the second calibration solution.
- 4) Check the slope and sensor zero-point, then put the electrode back into the armature. Select automatic temperature compensation and switch ON the controller.

NOTE

The slope should be close to 59 mV/pH, the zero-point close to 0 mV. The slope decreases and the zero error increases with time. When either value exceeds certain limits, the instrument displays an error message indicating that the electrode has to be replaced.

4.4.2 Buffers

At works the following buffers are stored:

- Calibration solutions: buffer solutions pH 4 and pH 7
- Inner buffer of the electrode: pH 7

If you want to use other calibration solutions, adjust the values - it does not matter if you start with the higher or the lower pH.

If you are using electrodes with a special inner buffer, adjust the pH value of the sensor buffer, since this value is used as zero for the calculation of the measured values. You will find the pH of the sensor buffer printed on the electrode.

4.5 Temperature compensation

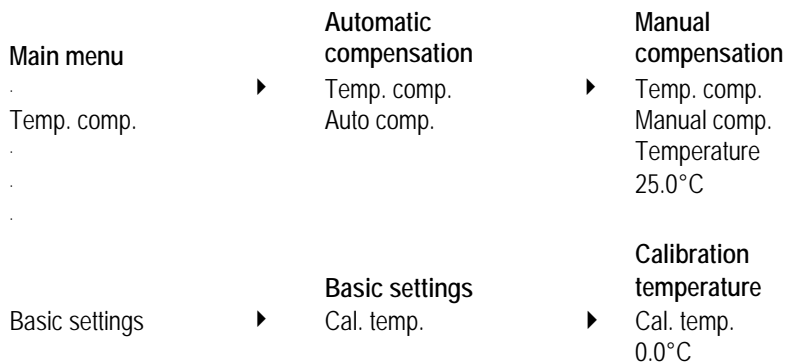

Select between two ways of compensation:

1) Automatic compensation with temperature sensor

Mind that the temperature sensor should always measure the medium temperature around the sensor. When pH sensor and temperature sensor are not immersed in the same solution, better switch to manual compensation.

2) Manual compensation

If the temperature can be regarded as constant, you can enter the temperature manually instead of measuring it continuously. The device will then compensate the temperature error of this temperature.

4.5.1 Calibration of the temperature measurement

If you connect the temperature sensor with a twin-core cable, slight deviations might occur between measured and real temperature. These deviations can be eliminated by calibration.

During start-up, measure the temperature manually and enter a correction term so that the display shows the exact temperature.

5. Adjustments of the controller

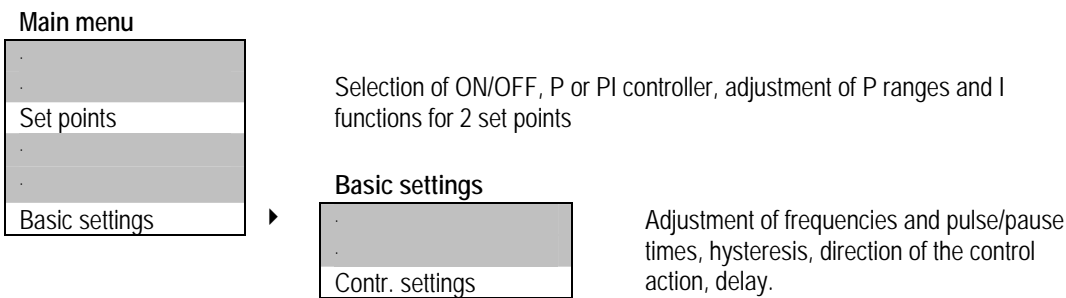

For any type of controller you have to enter one or two set points, and you have to tell the device whether these set points are reached by increasing or decreasing the measured value.

You can choose between three different controller versions:

ON/OFF controller

The ON/OFF controller switches ON if the measured value exceeds the set point and OFF if it drops back below it or vice versa. Dosage is always carried out with 100% (ON) or 0% (OFF). The parameter for an ON/OFF controller is the hysteresis.

P controller

The P controller or proportional controller reduces the dosage in the vicinity of the set point proportional to the control deviation. This is easily achieved if the analog output is used as steady control output. If the relays are used, the proportional reduction is achieved by either reducing the switch frequency (Impulse-frequency controller) or reducing the time within a given period of time in which the relay is ON (pulse-pause controller).

The parameters for a P controller are the P range and the impulse- frequency or the pulse+ pause time and the minimum pulse.

PI controller

The PI controller is a P controller with an additional I function. Adjustments and parameters are the same as for a P controller. Additionally the integral action time has to be adjusted which determines the I function.

The I function eliminates the P controller's disadvantage of a remaining steady-state deviation.

5.1 ON/OFF controller

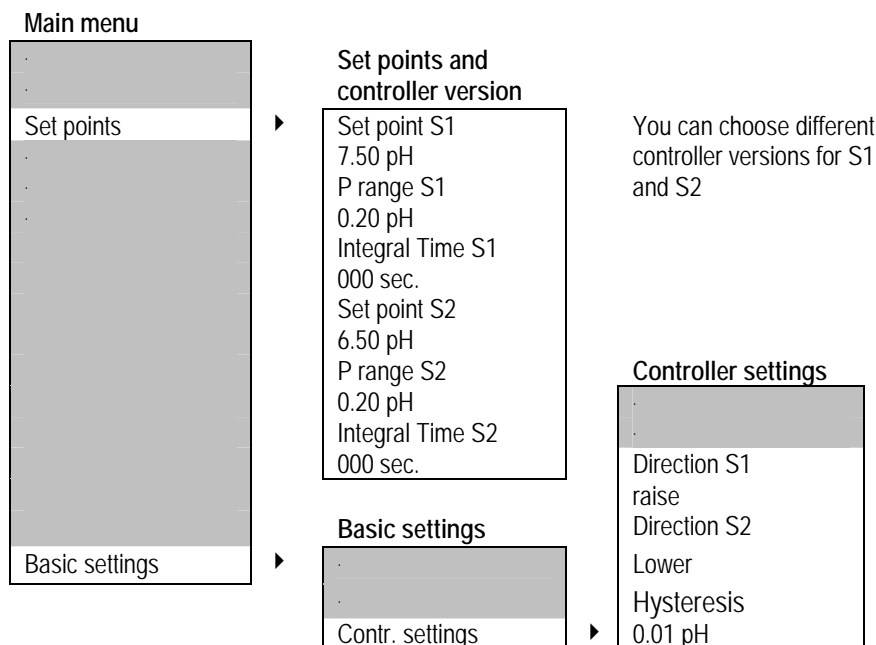

For an ON/OFF controller you have to set the following parameters:

1) Set points S1 and S2

Set point S1 refers to relay 1, set point S2 refers to relay 2.

2) P range and integral action time for S1 and S2

For an ON/OFF controller set P range = 0 and integral time = 0.

3) Acting direction for S1 and S2

Select "raise" if the dosage raises the measured value.

Select "lower" if the dosage lowers the measured value.

4) Optionally a hysteresis

The hysteresis prevents fast switching in the vicinity of the set point. If hysteresis is activated (by setting a value > 0) the relay switches only when the set point is exceeded by half the hysteresis.

5.2 P / PI controller as impulse-frequency controller

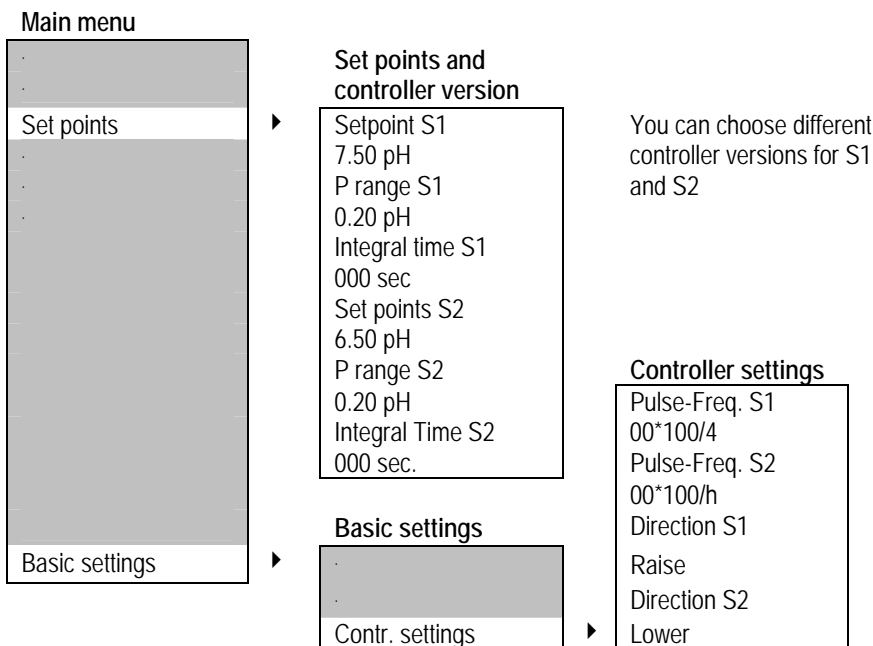

For an impulse-frequency controller you have to set the following parameters:

- 1) Set points S1 and S2**
S1 refers to relay 1, S2 refers to relay 2.
- 2) P range and integral action time for S1 and S2**
Adjust a P range > 0. For a P controller set integral time = 0, for a PI controller set an integral time > 0.
- 3) The acting direction for S1 and S2**
Select „raise“ if the dosage raises the measured value.
Select „lower“ if the dosage lowers the measured value.
- 4) Pulse-frequencies for S1 and S2**
Enter the maximum pulse-frequency that corresponds to 100% dosage.

5.3 P / PI controller as pulse-pause controller

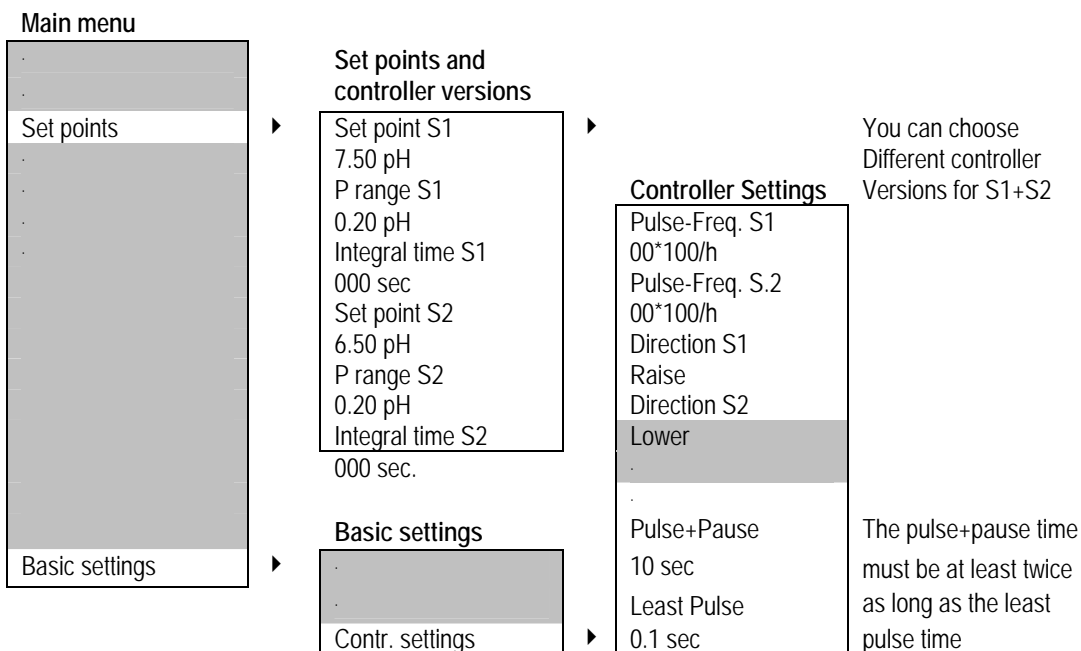

For a pulse-pause controller you have to set the following parameters:

1) Set points S1 and S2

S1 refers to relay 1, S2 refers to relay 2.

2) P range and integral action time

Adjust a P range > 0. For a P controller set integral time = 0, for a PI controller set an integral time > 0.

3) Pulse-frequencies for S1 and S2

Both frequencies must be set to 00, otherwise the controller will act as an impulse-frequency controller.

4) The acting direction for S1 and S2

Select „raise“ if the dosage raises the measured value.

Select „lower“ if the dosage lowers the measured value.

5) Pulse + pause time

Define a period of time during which the relay is proportionally to the control deviation ON (pulse) or OFF (pause), respectively.

6) Least pulse time

Set a minimum pulse time that the relay has to at least remain open to allow the actuator to react.

5.4 Activation and deactivation of the controller

The controller is activated and deactivated from the main display without any menus. Press key ▶ to switch from Manual Mode (controller OFF) to Automatic Mode (controller ON) and vice versa. The actual mode is indicated in the display.



WARNING

Make sure that the controller is deactivated before connecting dosing pumps or other actuators!

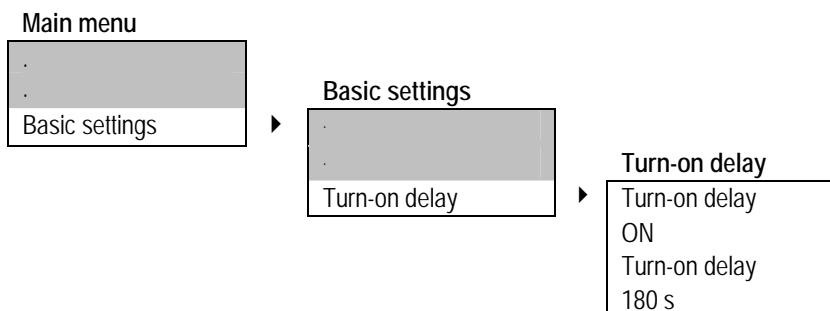

5.5 Turn-on delay

Set a delay time which has to pass before the controller is activated after start-up or power interrupt. This allows the measurement to settle and prevents inappropriate dosage of chemicals.

5.6 External controller stop

You can activate or deactivate the controller with an external switch by using the digital input. This feature requires no settings or adjustments. If the digital input is short-circuited, the controller stops, and the message „external controller stop“ appears in the display.

NOTE

This feature can also be used as lack-of water indication. Just connect a level sensor to the digital input.

5.7 Manual operation of the relays

6.99 pH	25.0°C
▼ <input type="checkbox"/> S1	<input type="checkbox"/> S2 Auto ←

1) If the controller is ON, switch it OFF with key ←. Instead of „Auto“ the display shows „Man“.

6.99 pH	25.0°C
↑ ← <input type="checkbox"/> S1	<input type="checkbox"/> S2 Man ←

6.99 pH	25.0°C
↑ ← <input type="checkbox"/> S1	<input type="checkbox"/> S2 Man

2) Switch to the operation mode of S1 with key ▲. The square to the left of S1 starts to flash.

6.99 pH	25.0°C
↑ ← <input checked="" type="checkbox"/> S1	<input type="checkbox"/> S2 Man

3) Switch ON relay 1 with key ←. The square to the left of S1 gets dark.

6.99 pH	25.0°C
↑ ← <input type="checkbox"/> S1	<input type="checkbox"/> S2 Man

4) Switch OFF relay 1 again with key ←. The square gets light.

6.99 pH	25.0°C
↑ ← <input type="checkbox"/> S1	<input type="checkbox"/> S2 Man

5) Switch to the operation mode of S2 with key ▲. The square to the left of S2 starts to flash.

6.99 pH	25.0°C
↑ ← <input type="checkbox"/> S1	<input checked="" type="checkbox"/> S2 Man

6) Switch ON relay 2 with key ←. The square to the left of S2 gets dark.

6.99 pH	25.0°C
↑ ← <input type="checkbox"/> S1	<input type="checkbox"/> S2 Man

7) Switch OFF relay 2 again with key ←. The square gets light.

6.99 pH	25.0°C
↑ ← <input type="checkbox"/> S1	<input type="checkbox"/> S2 Man ←

8) Leave the operation mode of relay 2 with key ▲. Both squares appear light, none flashes - You have left the operation mode.

For manual operation you need no menu.

- With key ← you switch OFF the controller.
- With key ▲ you switch between Manual operation <> operation mode S1 <> operation mode S2 <> manual operation.
- In the operation mode you can switch ON and OFF the selected relay with key ←.
- A flashing square indicates that the relay is in operation mode.
- A dark square indicates that the relay is switched ON.
- A light square indicates that the relay is switched OFF.

If you switch ON a relay it stays ON until you switch it OFF again manually!



WARNING

5.8 Limit values

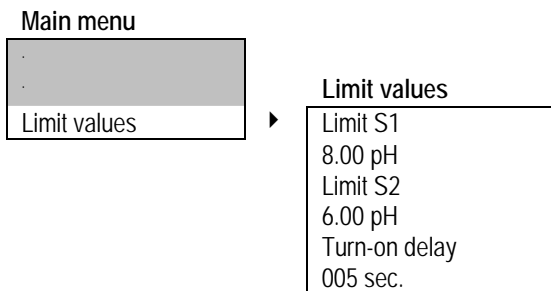

For the alarm, you can adjust two limits:

- Limit 1 is an upper limit. If the measured value exceeds limit 1, an alarm is issued.
- Limit 2 is a lower limit. The alarm is issued if the measured value drops below limit 2.

In case of alarm the display shows the message „limit 1“ (or 2, respectively) and relay 3 is switched ON. This relay can be used to activate an external horn or lamp.

NOTE The limit function is active only if the controller is set on automatic mode. When you switch the controller to MAN, the alarm is extinguished.

5.8.1 Turn-on delay

In some applications it happens regularly that the measured value exceeds a limit for a short period of time. To avoid having an alarm issued under these circumstances you can adjust a turn-on delay which has to pass before an alarm is issued. If the turn-on delay time is >0 then the alarm is issued only if the cause of alarm remains longer than the specified turn-on delay time.

5.9 Dosage check

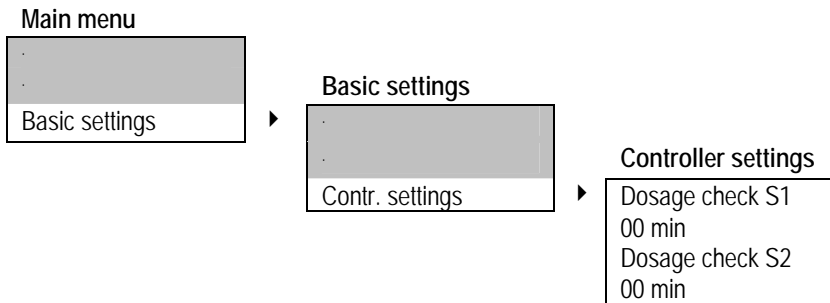

In the basic settings of the controller you can define, how long a controller is supposed to dose with 100% without raising alarm.

If the controller output is 100% for more than the specified time, this is interpreted as an indication of failure, and the device issues an alarm and deactivates the controller, thus stopping further dosage.

The dosage check is a safety catch to prevent hazardous chemicals to be set free in case of a defective dosing tube or tube connection.

NOTE In case of an alarm due to dosage check, only the controller concerned is deactivated.
NOTE If you set the dosage check time to 0 min, the dosage check function is deactivated.

6. Alarm

Additional to the limit function the device provides various check functions that raise alarm.

In case of an alarm, relay 3 switches, undelayed, and the cause of the alarm is indicated in the display.

If the cause of alarm is such that control is no longer possible or might even be dangerous, the controller is automatically deactivated until the alarm is switched off.

Switching off the alarm is done automatically by the device as soon as the cause of alarm is eliminated.

Sensor check during measurement

During measurement all connected sensors are checked. If an analog input does not receive a correct signal, for e. g. if a cable is broken or a sensor damaged, an alarm is issued, and the controller deactivated. Alarm and controller stop remain until the analog input receives correct signals again.

Sensor check during measurement

During measurement all connected sensors are checked. If an analog input does not receive a correct signal, for e. g. if a cable is broken or a sensor damaged, an alarm is issued, and the controller deactivated. Alarm and controller stop remain until the analog input receives correct signals again.

Dosage control

If a controller output is 100% longer than the defined dosage time, an alarm is issued, and the corresponding controller is deactivated. The alarm remains until the controller output drops below 100% - it can also be extinguished by setting the controller to manual mode.

Cause of alarm	only active in AUTO mode	deactivates controller
Slope error	no	no
Sensor zero	no	no
Error input 1	no	yes
Error input 2	no	yes
Limit	yes	no
Dosage	yes	yes

6.1 Error messages

Error message	Cause	Action
Slope error	The slope determined by calibration was higher than 65 mV/pH or lower than 50 mV/pH.	Please check the sensor connection and cable, and make sure that the calibration data stored in the instrument corresponds to the calibration solutions used. Also make sure that the temperature settings are correct. Then repeat the calibration. If the error message remains, the sensor has to be replaced or regenerated.
Sensor zero	The zero deviation determined by calibration was higher than 60 mV or lower than -60 mV.	Please follow the procedure described above. Make sure that the sensor buffer stored in the calibration data corresponds to the sensor used. If the error remains, at least the reference electrode has to be replaced or regenerated.
Error input 1	The pH or ORP electrode gives no signal.	Please check the connections, the cable and the sensor for signs of damage.
Error input 2	The temperature sensor gives no signal.	Please check the connections, the cable and the sensor for signs of damage. This message also appears if automatic temperature compensation was selected although no temperature sensor was used.
Limit 1 / 2	The measured value exceeded limit 1 (or dropped below limit 2, respectively).	Please check the dosing and readjust the control parameters, if necessary.
Dosage	Pump 1 (or 2, resp.) feeds with 100% for more than the defined period of time.	Please check the dosing, especially the feeding tubes and connections. Caution! Carefully check for leaking chemicals!
Ext. controller stop	The digital input has been short-circuited.	This only indicates the external controller stop. If, however, you have connected a level sensor, this message appears due to the „lack of water“ alarm.

7. Output

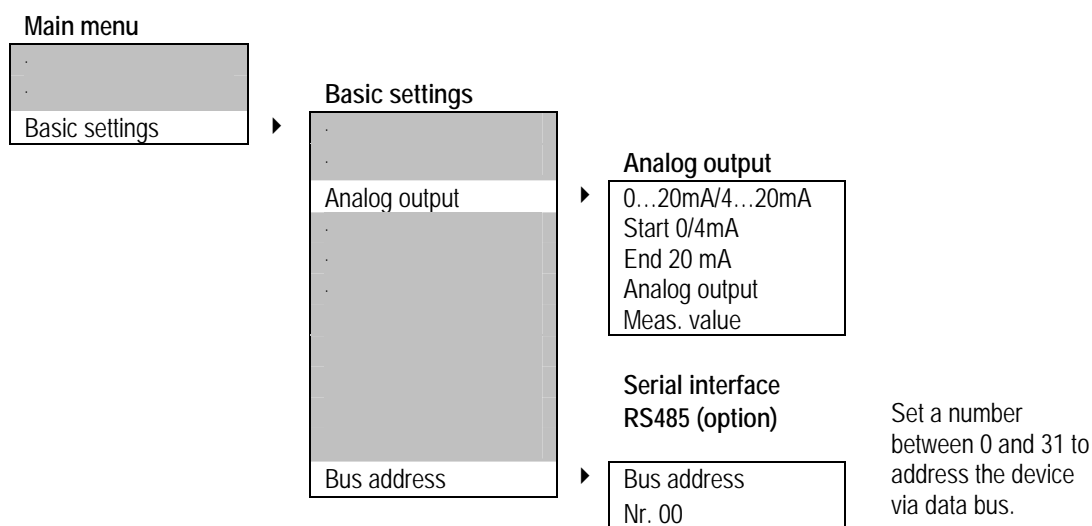

7.1 Current output

You can read out the measured value as 0/4...20 mA signals via the current output.

With the setting 4...20 mA the resolution is lower, but defective cable connections are immediately evident. With the parameters Begin and End you define which part of the measuring range you want to read out.

Alternatively you can use the current output as steady-state controller output. In that case assign the current output to controller S1 or S2, respectively.

7.2 Serial interface RS485 (option)

The devices are available with serial interface RS485 by means of which they can be integrated in a data bus system. Via the interface, all settings, measured and control values as well as any error messages can be read out digitally.

Devices with RS485 are automatically delivered with the leaflet „Information on the RS485“ which contains instructions on the communication and a complete list of the functions available via interface.

8. Operation and maintenance

8.1 Maintenance of the device

The device does not require any maintenance. There is no need for readjustment. If you want to have the device checked regularly, you are welcome to send it to KROHNE Water Solutions. Alternatively the device can be checked on site by one of our engineers.

8.2 Display contrast

With devices in wall-mounting enclosures the display contrast can be adjusted to the actual light conditions by means of a potentiometer. It is indicated in the connection diagram with the word „display“.

8.3 Exchange fuse



WARNING

Devices in wall-mounting enclosures have an internal fuse which has to be replaced at need. You will find a spare fuse fixed to the inside of the terminal cover. Information on the fuse can be found in the chapter „Technical data“.

To exchange the fuse, open the front carefully. The fuse is located on the right hand side. It is kept in place by a Bayonet lock. Turn the lock to the left until the fuse pops up. Exchange it and fix the new fuse by turning the lock to the right. Put the front back on and fix it tightly.

Disconnect the power supply before opening the device!

Mind that the cable connections to the front are not damaged, broken or torn during the process!



ATTENTION

8.4 Cleaning

The front and the display should not get in touch with organic solutions such as methanol. Never let water get inside the device. We suggest to simply use a damp cloth for cleaning.

8.5 Maintenance of the pH or ORP measurement

The metallic surface of the ORP electrode must be cleaned regularly. pH and reference electrodes change with time, so their characteristics have to be determined regularly by means of calibration.

NOTE

The instrument checks the sensor's characteristic parameters after each calibration and displays an error message if the sensor has to be replaced. See chapter „Error messages“.

8.6 Disposal

For disposal please notice that the device contains electrolyte capacitors which have to be disposed separately.

8.7 Service

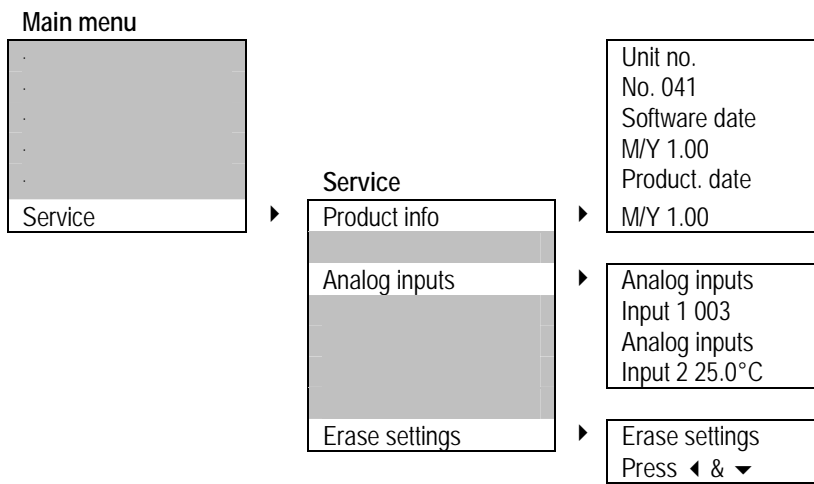

In this menu you will find information which is especially important for any inquiries, updates or problems.

8.7.1 Product info

These figures allow a precise identification of the device (hardware and software).

8.7.2 Analog inputs

Here you can see the raw data the device obtains from the sensors. They are not influenced by compensations or calibration and offer valuable information in case of problems with the measurement or the device.

If you have problems interpreting this data, send them to your supplier together with the device data and ask for support.

8.7.3 Erase settings (reset)

With this function you can erase all customer settings and restore the original at-works data.

The process takes some 30 seconds. When it is finished the display will show the measured value, and the controller will switch off.

9. Technical data

9.1 Technical data

Feature	PAC 050 R	PAC 050 W
Version	panel-type converter	wall-mounting enclosure
Dimensions (w x h x d)	96 x 96 x 127 mm / 3.8 x 3.8 x 5"	165 x 160 x 80 mm / 6.5 x 6.3 x 3.1"
Weight	0.8 kg / 1.8 lbs	1.0 kg / 2.2 lbs
Terminals	screw terminals max. 1.5 mm ²	Spring clamp max. 1,5 mm ²
Protection class	IP 54 (front), IP 30 (housing)	IP 65
Power supply	230 V AC +/-10 %, 50/60 Hz, alternativ 110 V AC oder 24 V AC	
Internal fuse	none	230 V : 63 mA slow 110 V : 125 mA slow 24 V : 800 mA semi-slow
Power consumption	10 VA	10 VA
Display	LCD, 2-line, 2x16 characters, illuminated background measured value and temperature with dimensions indication of relay status	
Current output	0/4...20 mA, galvanically isolated, max. burden 500 Ohm	
Interface (option)	RS485, Baud rate 9600, data format 8 Bit, 1 Start and 1 Stop bit	
Controller	ON/OFF controller with hysteresis, P or PI controller as Pulse- Pause- or Impulse-frequency controller, steady controller, bidirectional PI control action, adjustable onset-delay, dosage control function, manual operation of the relays, controller stop via external switch or level sensor (lack-of-water sensor)	
Set points	2 set points adjustable within the measuring range	
Alarm function	with min. and max. limit and turn-on delay	
Contact rating	6 A / 250 V, max. 550 VA resistive load (with RC protective circuit)	
Operation temperature	0...+50°C / 32...+120°F	
Storage temperature	-20...+65°C / -5...+150°F	
Humidity	max. 90% at 40°C / 105°F non-condensing	

9.2 Dimensions

9.2.1 Panel-mounting enclosure

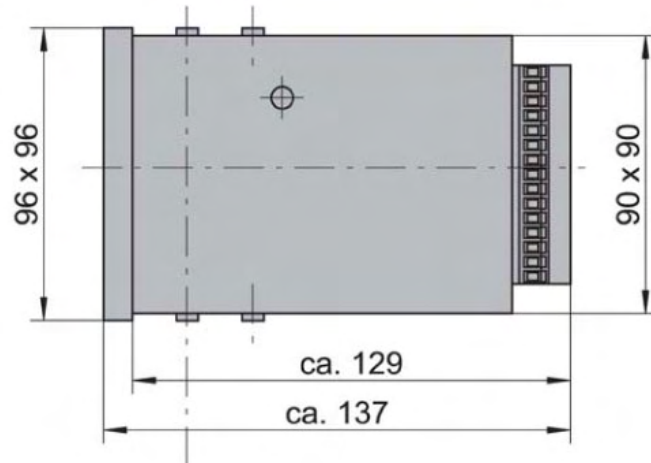

9.2.2 Wall-mounting enclosure

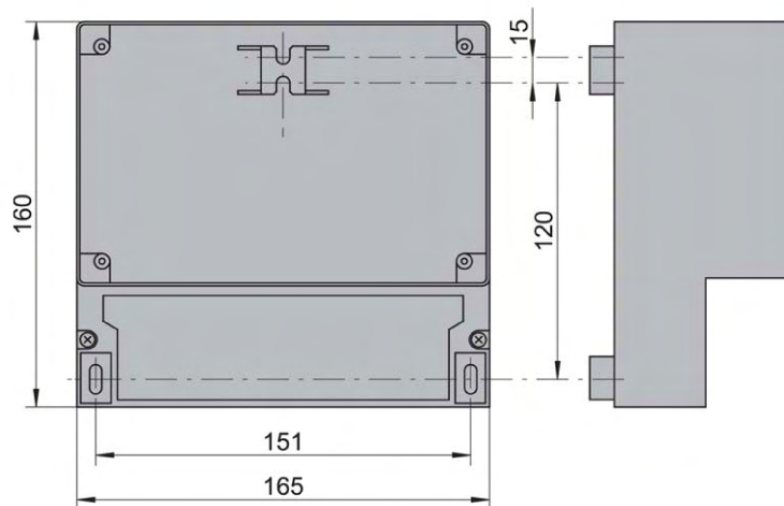

10. Device return form

This device has been carefully manufactured and tested. If installed and operated in accordance with these operating instructions, it will rarely present any problems. Should you nevertheless need to return a device for inspection or repair, please pay strict attention to the following points:

Due to statutory regulations on environmental protection and safeguarding the health and safety of our personnel, KROHNE Water Solutions may only handle, test and repair returned devices that have been in contact with products without risk to personnel and environment.

This means that KROHNE Water Solutions can only service this device if it is accompanied by the following certificate confirming that the device is safe to handle.

If the device has been operated with toxic, caustic, flammable or water-endangering products, you are kindly requested:

to check and ensure, if necessary by rinsing or neutralizing, that all cavities are free from such dangerous substances,

to enclose a certificate with the device confirming that is safe to handle and stating the product used.

We cannot service this device unless accompanied by such a form.

SPECIMEN certificate

Company:..... Address:.....

Department:..... Name:.....

Tel.-No.:..... Fax No.:.....

Email:.....

The enclosed device

Type:.....

KROHNE Water Solutions Order No. or Series No.:.....

has been operated with the following liquid:.....

Because this liquid is

- water-hazardous toxic caustic flammable

we have

- checked that all cavities in the device are free from such substances
 flushed out and neutralized all cavities in the device

We confirm that there is no risk to humans or environment through any residual liquid contained in this device.

11. Customer settings - for reference

Device		Identification / location	
Type	Date of installation
Serial number	Software version
Measurement			
<input type="checkbox"/> pH		<input type="checkbox"/> ORP	
Cal. solution 1pH		
Cal. solution 2pH		
Sensor bufferpH		
Temperature compensation			
<input type="checkbox"/> Manual		<input type="checkbox"/> Automatic	
Temperature°C	Correction°C
		<input type="checkbox"/> Pt100	
Analog output			
Output 1			
<input type="checkbox"/> 0...20mA	<input type="checkbox"/> 4...20mA		
for <input type="checkbox"/> pH/ORP			
<input type="checkbox"/> Controller S1	<input type="checkbox"/> Controller S2		
Start		
End		
Controller			
Controller S1		Controller S2	
Acting direction		Acting direction	
<input type="checkbox"/> raise	<input type="checkbox"/> lower	<input type="checkbox"/> raise	<input type="checkbox"/> lower
Set point	Set point
Hysteresis	Hysteresis
P range	P range
Integral times	Integral times
Pulse + pause times	Pulse+ pause times
Minimum pulses	Minimum pulses
Pulse frequency*100/h	Pulse frequency*100/h
Turn-on delay			
Delay timemin.		
Alarm			
Limit S1	Limit S2
Delay timemin.		
<input type="checkbox"/> normally closed	<input type="checkbox"/> normally open	<input type="checkbox"/> pulse contact	<input type="checkbox"/> perm. contact
Serial interface RS 485			
Bus address		