



OPTISENS PAS 2000 Handbook

pH and ORP sensors

All rights reserved. It is prohibited to reproduce this documentation, or any part thereof, without the prior written authorisation of KROHNE Messtechnik GmbH & Co. KG.

Subject to change without notice.

Copyright 2008 by KROHNE Messtechnik GmbH & Co.KG - Ludwig-Krohne-Straße 5 - 47058
Duisburg

1	Safety instructions.....	5
1.1	Intended use.....	5
1.2	Safety instructions from the manufacturer.....	5
1.2.1	Copyright and data protection.....	5
1.2.2	Disclaimer.....	5
1.2.3	Product liability and warranty.....	6
1.2.4	Information concerning the documentation.....	6
1.2.5	Display conventions.....	7
1.3	Safety instructions for the operator.....	7
2	Device description.....	8
2.1	Scope of delivery.....	8
2.2	Device description.....	9
2.3	Nameplates.....	10
2.3.1	OPTISENS PAS 2000 pH sensor.....	10
2.3.2	OPTISENS PAS 2000 ORP sensor.....	11
3	Installation.....	12
3.1	Notes on installation.....	12
3.2	Storage & Transport.....	12
3.3	Installing the sensor.....	13
3.3.1	Basic installation instructions.....	13
3.3.2	Mounting to MAA 2000 telescopic rod immersion holder.....	13
3.3.3	MAA 2000 sensor holder and telescopic rod.....	16
3.3.4	Assembly of PAS 2000 to MAA 2000 slide rail immersion holder.....	17
3.3.5	Cable connections.....	18
3.4	Mounting the electrode.....	18
4	Electrical connections.....	20
4.1	Safety instructions.....	20
4.2	Cable connections.....	20
5	Operation.....	21
5.1	Sensor display.....	21
5.2	Menu for sensors.....	21
5.2.1	Menu for PAS 2000 pH.....	21
5.2.2	Menu for PAS 2000 ORP.....	23
5.3	Calibration.....	24
5.3.1	Calibrating pH.....	25
5.3.2	Adjusting ORP.....	26
5.4	Scaling.....	26
6	Service.....	27
6.1	Maintenance.....	27
6.1.1	Broken electrode.....	27

6.1.2	Error messages	27
6.1.3	Incorrect measurements.....	28
6.1.4	Cleaning of the flushing nozzle	28
6.2	Cleaning	28
6.3	Spare parts availability	30
6.4	Availability of services.....	30
6.5	Returning the device to the manufacturer	31
6.5.1	General information	31
6.5.2	Form (for copying) to accompany a returned device	32
6.6	Disposal.....	32
7	Technical data	33
7.1	Measuring principle	33
7.2	Data table	34
7.3	Dimensions & Weight.....	36
8	Appendix	38
8.1	pH as a function of mV	38
8.2	pH temperature dependency	39
8.3	Support information form	40
8.4	Setup information form	41
9	KROHNE measuring technology - Product overview.....	44

1.1 Intended use

The OPTISENS PAS 2000 Sensors are used to measure pH value or ORP potential in water and wastewater treatment plants and other industrial applications.

1.2 Safety instructions from the manufacturer

1.2.1 Copyright and data protection

The contents of this document have been created with great care. Nevertheless, we provide no guarantee that the contents are correct, complete or up-to-date.

The contents and works in this document are subject to German copyright. Contributions from third parties are identified as such. Reproduction, processing, dissemination and any type of use beyond what is permitted under copyright requires written authorisation from the respective author and/or the manufacturer.

The manufacturer tries always to observe the copyrights of others, and to draw on works created in-house or works in the public domain.

The collection of personal data (such as names, street addresses or e-mail addresses) in the manufacturer's documents is always on a voluntary basis whenever possible. Whenever feasible, it is always possible to make use of the offerings and services without providing any personal data.

We draw your attention to the fact that data transmission over the Internet (e.g. when communicating by e-mail) may involve gaps in security. It is not possible to protect such data completely against access by third parties.

We hereby expressly prohibit the use of the contact data published as part of our duty to publish an imprint for the purpose of sending us any advertising or informational materials that we have not expressly requested.

1.2.2 Disclaimer

The manufacturer will not be liable for any damage of any kind by using its product, including, but not limited to direct, indirect, incidental, punitive and consequential damages.

This disclaimer does not apply in case the manufacturer has acted on purpose or with gross negligence. In the event any applicable law does not allow such limitations on implied warranties or the exclusion of limitation of certain damages, you may, if such law applies to you, not be subject to some or all of the above disclaimer, exclusions or limitations.

Any product purchased from the manufacturer is warranted in accordance with the relevant product documentation and our Terms and Conditions of Sale.

The manufacturer reserves the right to alter the content of its documents, including this disclaimer in any way, at any time, for any reason, without prior notification, and will not be liable in any way for possible consequences of such changes.

1.2.3 Product liability and warranty

The operator shall bear responsibility for the suitability of the device for the specific purpose. The manufacturer accepts no liability for the consequences of misuse by the operator. Improper installation and operation of the devices (systems) will cause the warranty to be void. The respective "Standard Terms and Conditions" which form the basis for the sales contract shall also apply.

1.2.4 Information concerning the documentation

To prevent any injury to the user or damage to the device it is essential that you read the information in this document and observe applicable national standards, safety requirements and accident prevention regulations.

If this document is not in your native language and if you have any problems understanding the text, we advise you to contact your local office for assistance. The manufacturer can not accept responsibility for any damage or injury caused by misunderstanding of the information in this document.

This document is provided to help you establish operating conditions, which will permit safe and efficient use of this device. Special considerations and precautions are also described in the document, which appear in the form of underneath icons.

1.2.5 Display conventions

The following symbols are used to help you navigate this documentation more easily:



DANGER!

This symbol designates safety advice on handling electricity.



WARNING!

These warning signs must be observed without fail. Even only partial disregarding such warnings can result in serious health damage, damage to the device itself or to parts of the operator's plant.



CAUTION!

These warnings must be observed without fail. Even only partial disregarding such warnings can lead to improper functioning of the device.



LEGAL NOTICE!

This symbol designates information on statutory directives and standards.



NOTE!

This symbol designates important information for the handling of the device.



• **HANDLING**

This symbol designates all instructions for actions to be carried out by the operator in the specified sequence.



• **CONSEQUENCE**

This symbol designates all important consequences of the previous actions.

1.3 Safety instructions for the operator



WARNING!

*In general, devices from the manufacturer may only be installed, commissioned, operated and maintained by properly trained and authorized personnel.
This document is provided to help you establish operating conditions, which will permit safe and efficient use of this device.*

2.1 Scope of delivery

**INFORMATION!**

Inspect the cartons carefully for damage or signs of rough handling. Report damage to the carrier and to the local office of the manufacturer.

**INFORMATION!**

Check the packing list to check if you received completely all that you ordered.

**INFORMATION!**

Look at the device nameplate to ensure that the device is delivered according to your order. Check for the correct supply voltage printed on the nameplate.

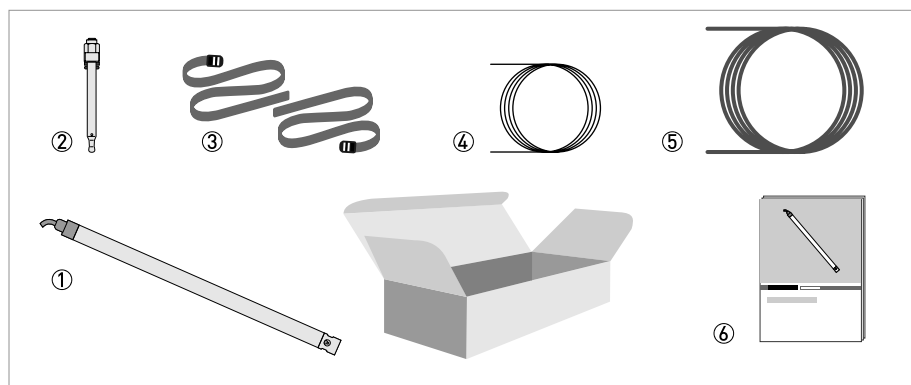

Figure 2-1: Standard scope of delivery for PAS 2000 pH sensor

- ① PAS 2000 pH sensor
- ② Gel-filled pH combination electrode
- ③ 2 straps
- ④ 10 m / 33 ft cable
- ⑤ 10 m / 33 ft flush hose
- ⑥ Complete documentation

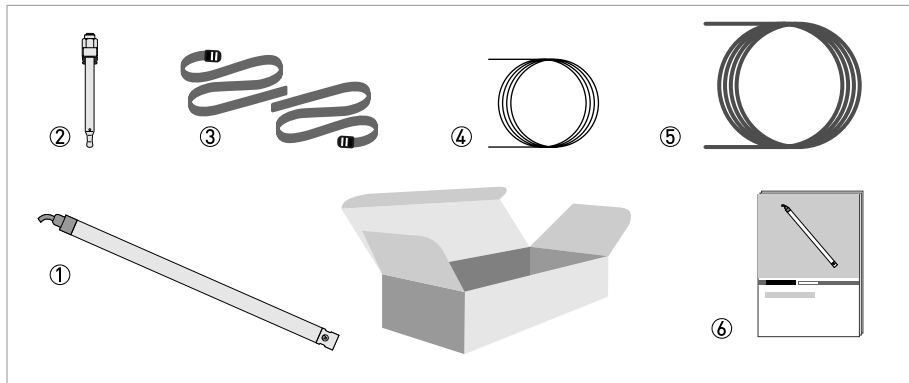

Figure 2-2: Standard scope of delivery for PAS 2000 ORP sensor

- ① PAS 2000 ORP sensor
- ② Gel-filled ORP combination electrode
- ③ 2 straps
- ④ 10 m / 33 ft cable
- ⑤ 10 m / 33 ft flush hose
- ⑥ Complete documentation

Accessories available for PAS 2000 sensors

- MAA 2000 Insertion Holder, Telescopic Rod for PAS 2000 (inclusive telescopic rod plus rod holder, handrail mounting bracket, sensor adapter)
- MAA 2000 Side Wall Mounting for PAS 2000
- Signal cable extension for OPTISENS 2000 sensors, 10 m / 33 ft
- Signal cable extension for OPTISENS 2000 sensors, 10 m / 33 ft

Consumables/Spare parts available for PAS 2000 sensors

- pH - electrode PAS 2000 pH
- ORP- electrode PAS 2000 ORP

2.2 Device description



INFORMATION!

This manual details installation procedures and operational features of the KROHNE OPTISENS 2000 pH and ORP sensors. Menu navigation and technical data for the MAC 080 converter can be found in the OPTISENS MAC 080 manual.

The PAS 2000 sensors are manufactured in SIS2343 (316SS) stainless steel and PVC. The sensors are mounted onto the MAA 2000 Adjustable telescopic rod holder using a POM adapter. An adjustable stainless steel slide rail holder is available as an option. All PAS 2000 sensors incorporate automatic cleaning as standard. The electronics is protected in the rugged casing, ensuring its reliability in very demanding environments.

The sensor has a fixed, shielded 10 m / 33 ft cable used for signal transmission between the sensor and the MAC 080 converter. The cable sheath is made of Hytrel and is highly resistant to aggressive materials and fluids.

2.3 Nameplates



INFORMATION!

Look at the device nameplate to ensure that the device is delivered according to your order. Check for the correct supply voltage printed on the nameplate.

2.3.1 OPTISENS PAS 2000 pH sensor

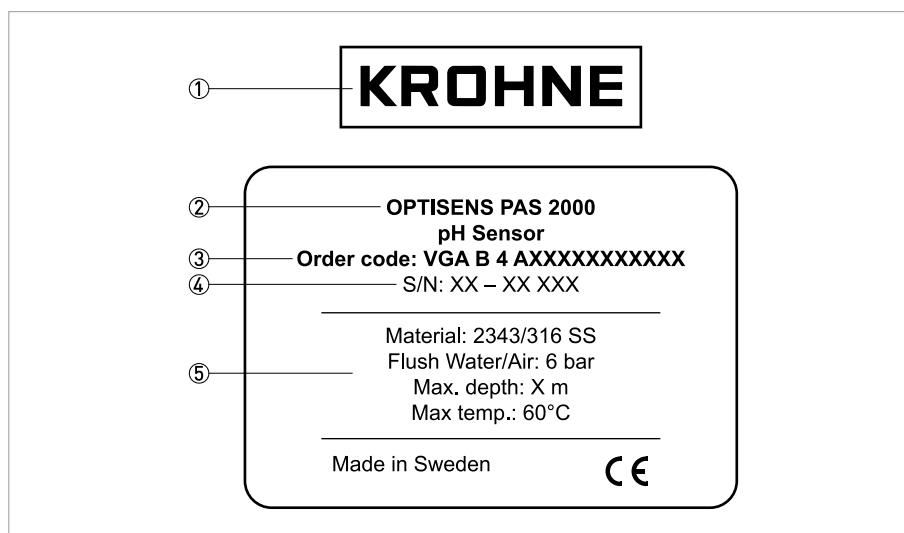

Figure 2-3: Nameplate OPTISENS PAS 2000 pH sensor

- ① Manufacturer
- ② Device type
- ③ Order code
- ④ Serial number
- ⑤ Sensor information

2.3.2 OPTISENS PAS 2000 ORP sensor

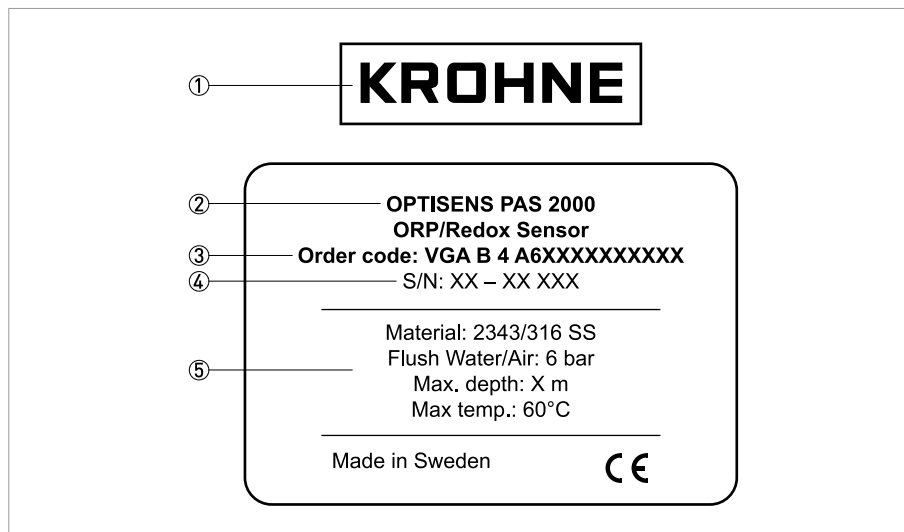

Figure 2-4: Nameplate OPTISENS PAS 2000 ORP

- ① Manufacturer
- ② Device type
- ③ Order code
- ④ Serial number
- ⑤ Sensor information

3.1 Notes on installation

**INFORMATION!**

Inspect the cartons carefully for damage or signs of rough handling. Report damage to the carrier and to the local office of the manufacturer.

**INFORMATION!**

Check the packing list to check if you received completely all that you ordered.

**INFORMATION!**

Look at the device nameplate to ensure that the device is delivered according to your order. Check for the correct supply voltage printed on the nameplate.

3.2 Storage & Transport

- Store the device in a dry, dust-free location.
- Avoid continuous direct sunlight.
- The original packaging is designed to protect the equipment. It has to be used if you the device is transported or send back to the manufacturer.

3.3 Installing the sensor

3.3.1 Basic installation instructions

The electrode should be placed deep enough so that it always stays in the measuring media, even when the level varies (see figure 3-1). The measuring ability of the electrode is influenced negatively if the column of liquid to be measured is too large. For optimal results the column should not exceed 300 mm / 12".

**NOTE!**

To protect the sensor from damage, the sensor should never be fully submerged into water. Therefore a maximal immersion depth of 800 mm / 31" has to be maintained.

The sensor should be mounted in a vertical position. In some applications it may be desirable to mount at a certain angle. In this case the angle from the horizontal plane should be greater than or equal to 45°.

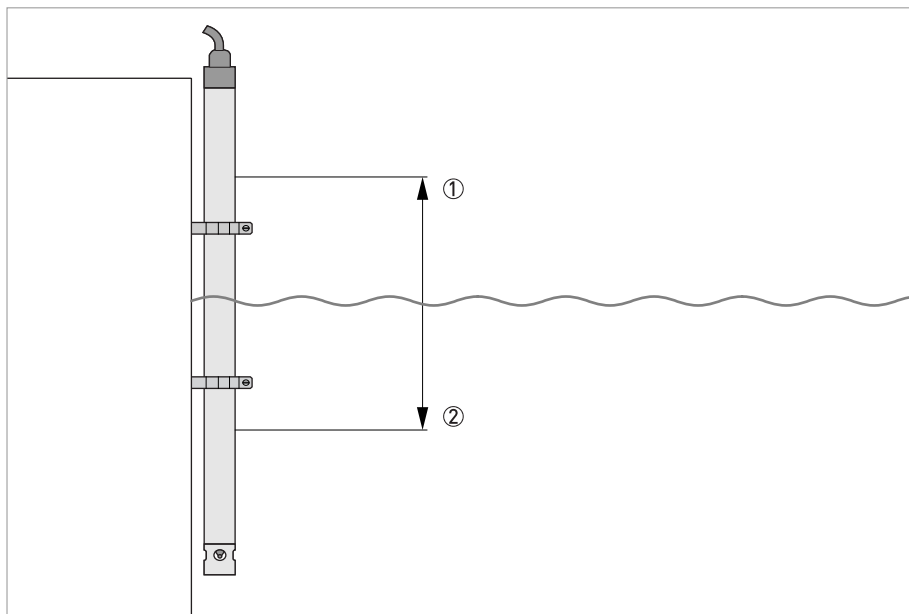

Figure 3-1: Installing the PAS 2000 in a flume

3.3.2 Mounting to MAA 2000 telescopic rod immersion holder

The mounting bracket of the telescopic rod is mounted to a handrail or a separate holder. In case a handrail is not available, a mounting post with a vertical bar for sensor mounting can be purchased from the manufacturer.

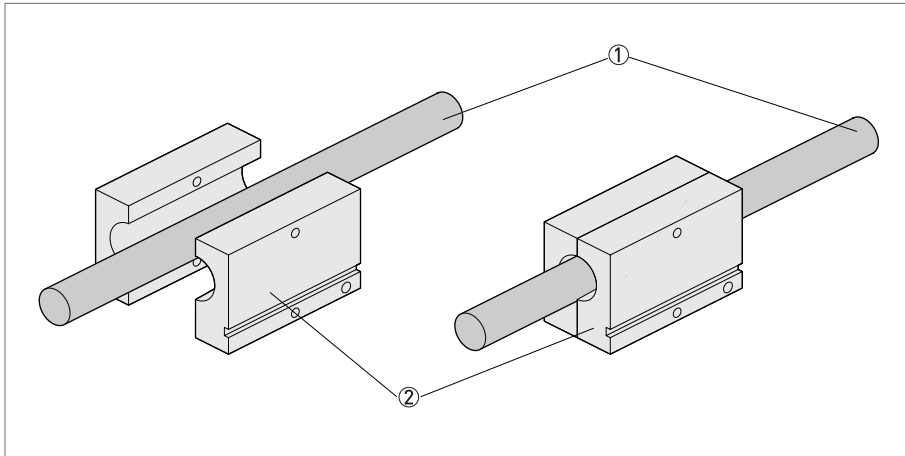

Figure 3-2: Placing the rod holder around the rod

- ① Telescopic rod
- ② Rod holder

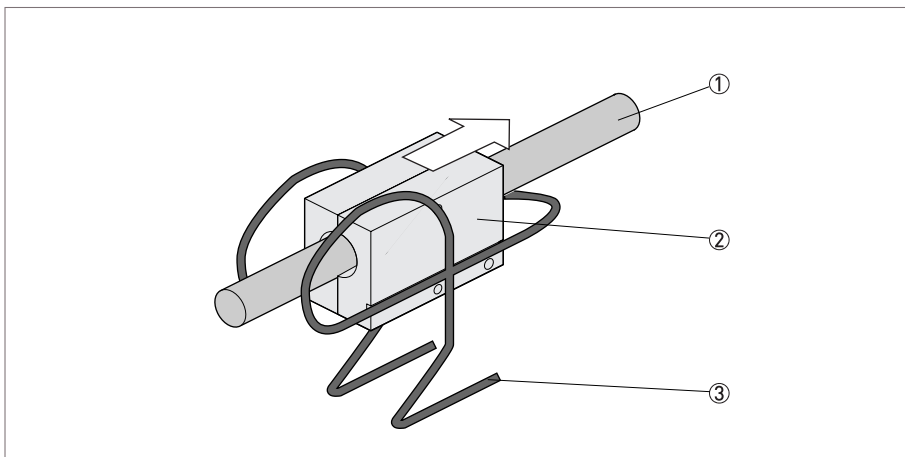

Figure 3-3: Inserting the rod holder into the mounting bracket

- ① Telescopic rod
- ② Rod holder
- ③ Mounting bracket

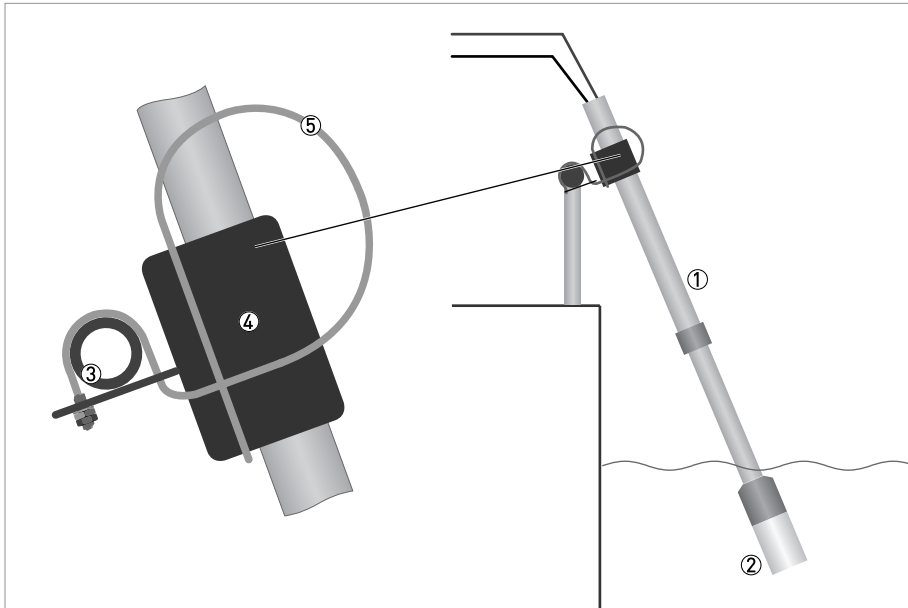

Figure 3-4: OPTISENS MAA 2000 Telescopic rod immersion holders

- ① Telescopic rod
- ② Sensor holder
- ③ Handrail with mounting bracket attached
- ④ Rod holder
- ⑤ Mounting bracket



CAUTION!

Do not extend the rod sections beyond the black lines. This could lead to rod damage.



CAUTION!

The sensor should be mounted in a vertical position. In some applications it may be desirable to mount at a certain angle. In this case the angle from the horizontal plane should be greater than or equal to 45°.



Mounting to telescopic rod immersion holder

- Mount the flexible mounting bracket on an existing handrail or on a separate holder, diameter 32...50 mm / 1.3...2.0" or square 28...42 mm / 1.1...1.7". The bent lip on the mounting plate shall be on top and faced toward the liquid or tank.
- Adjust the mounting bracket to the correct angle and tighten the nuts.
- ➔ The bracket shall be fixed to the rail, and must not be able to rotate around it.
- Adjust the length of the telescopic rod as necessary by twisting the nuts while holding the rod. Do not extend the rod sections beyond the black lines. This could lead to rod damage.
- Insert the PVC rod holder with the telescopic rod into the mounting bracket. Make sure that the guide tracks of the rod holder are properly seated in the bracket.
- Fasten the safety-locking clamp.
- Check that the mounting bracket is safely fixed to the rail for the spring to work the way it is intended.

3.3.3 MAA 2000 sensor holder and telescopic rod

In standard applications the PAS 2000 telescopic rod version gets delivered pre-assembled. In case the assembly needs to be done on site, the sensor is inserted into the telescopic rod and fixed with two POM half shells, which additionally integrate the flushing system (see chapter 8).



NOTE!

To ensure easy access to the electrode in case of maintenance, make sure that the removable part of the electrode holder is fixed clearly outside of the POM sensor holder.

3.3.4 Assembly of PAS 2000 to MAA 2000 slide rail immersion holder

As an alternative way of mounting the sensor, an adjustable slide rail holder is available.

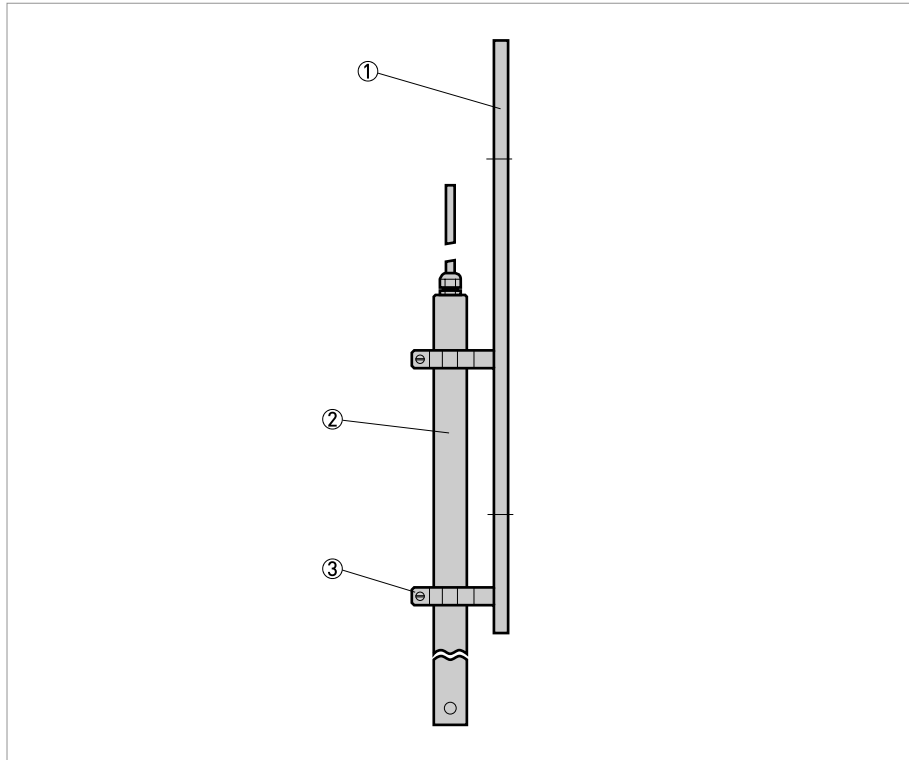

- ① Slide rail
- ② Sensor
- ③ 28 mm / 1.10" clamp



NOTE!

Please make sure that the assembly is mounted in a vertical position. In some applications it may be desirable to mount at a certain angle. In this case the angle from the horizontal plane should be greater than or equal to 45°.



Mounting instructions:

- Mount the slide rail assembly to the side wall of the basin or open channel using the two predrilled holes. The adjustable limit stop should be on the bottom and the two sliding clamps above.
- Take the two clamps off from the slide rail and mount them around the sensor housing. Please make sure the two guide tracks line-up in one straight line to each other. See figure 3-4!
- Slide the sensor with the two clamps into the slide rail and make sure that the guide tracks of the two clamps are properly seated.
- Adjust the sensor position as necessary (see chapter 3.3.2.) and fasten the limit stop.

3.3.5 Cable connections

Connect the sensor to the MAC 080 converter using the connector on the end of the attached sensor cable. In the event that two sensors are to be connected to the same MAC 080 converter, use the optional junction box.

See MAC 080 handbook for details.

3.4 Mounting the electrode

**NOTE!**

If the electrode has been in the cap for an extended period of time, salt crystals may need to be rinsed away with water.

**NOTE!**

If the electrode cannot be immersed into the measuring media before it is put to use, the electrode's small, plastic protective cover should be filled with a buffer solution of pH 7.



- Connect the supply voltage. Remove the protective cap from the electrode probe.
- In order to mount an electrode the electrode holder at the lower end of the sensor must be taken off.
- The electrode is mounted in the electrode holder by taking the enclosed nut, washer and O-ring and threading them onto the electrode.
Note: Adjust the electrode position so that the diaphragm on the lower part of the electrode is in contact with the measuring media.
- Tighten the nut with your hand.
- Remove the protective cover over the connector on top of the electrode and plug in the cable coming from the electronic inside the sensor rod.
- Feed the cable into the sensor rod. It is easier to get the cable in place if the holder is turned so the cable gets curled. Be careful not to damage the sealing or the cable.
- Mount the electrode holder back into the tube. Be careful not to damage the sealing.

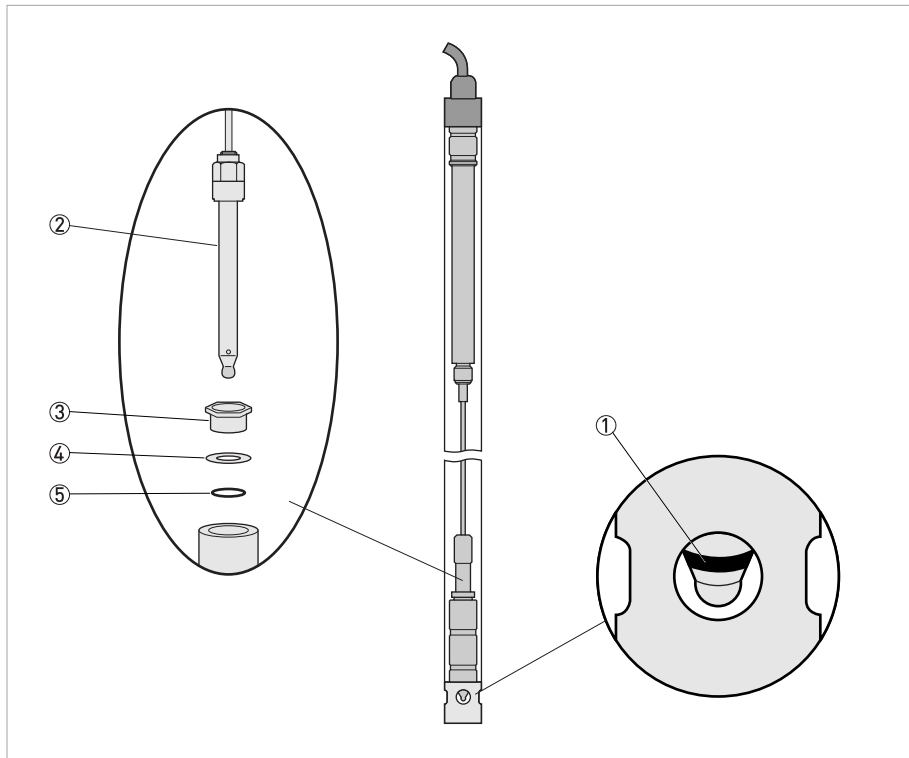

Figure 3-5: Mounting the electrode

- ① Diaphragm
- ② Electrode
- ③ Nut
- ④ Washer
- ⑤ O-ring

4.1 Safety instructions



DANGER!

All work on the electrical connections may only be carried out with the power disconnected. Take note of the voltage data on the nameplate!



DANGER!

Observe the national regulations for electrical installations!



WARNING!

Observe without fail the local occupational health and safety regulations. Any work done on the electrical components of the measuring device may only be carried out by properly trained specialists.



INFORMATION!

Look at the device nameplate to ensure that the device is delivered according to your order. Check for the correct supply voltage printed on the nameplate.

4.2 Cable connections



INFORMATION!

Please refer to the MAC 080 manual for detailed information.

Connect the sensor to the MAC 080 converter using the connector on the end of the attached sensor cable. In the event that two sensors are to be connected to the same converter, use the optional junction box.

5.1 Sensor display

By simultaneously pressing ↓ and ← you alter between MAC 080 main menu and the sensor information display for the selected sensor. PAS 2000 has two information pages. The first one shows in addition to the measured value maximum, minimum and average values for the last 24 hours. The values are based on hour values which means they may jump when a new hour starts and the oldest is skipped.

The second information display shows the date of the last calibration (PAS 2000 pH only) and the date the electrode was changed.

5.2 Menu for sensors

Use ↑ or ↓ to select the sensor in the main display. The menu for the selected sensor is accessed by pressing ← for five seconds. If the selected sensor is not active (the text **No transmitter** is shown) a warning is displayed that asks you to make another choice in order to show the sensor menu.

5.2.1 Menu for PAS 2000 pH

Menu "Settings"

Submenu	Description
Tag	Name of the sensor (10 characters) shown in the main display.
I-Time	Integration time or dampening - can be set up to 999 seconds. Normal value is 5-10 seconds.
Decimals	"1 or "2", number of decimals to show the measured value (only pH).
Reset day	"Yes" or "No", Yes resets the day calculation of min- max- and average.
Analog	"None" , "Out1", "Out2", "Out3", "Out4", "Out1+2", or "Out3+4". Pick which analog output(s) to be used with sensor.

Menu "Calibrate"

Submenu	Description
Take sample	"No", "Smart", or "manual". Refer to chapter 10 for details.
Cal Temp	Temperature at which calibration was done.
Measure Temp	Temperature of measured media.
Slope %	Shows the current condition of the electrode. A value between 93 % and 102 % is acceptable.
Sample 1 pH	Actual pH for the first buffer.
Sample 2 pH	Actual pH for the second buffer.
Calibrated	Date of last air calibration.
New electr.	Date when electrode was last changed. Push ← to edit the date, then ← again to store it.

Menu "Cleaning"

Submenu	Description
	Press \leftarrow to go to the cleaning program
Cleaner	"None", "Flush" or "Brush". Do not select "Brush" since this does not exist for this sensor.
Interval min	0...999 minutes, time between cleaning cycles.
Length sec	0...999 seconds, duration of flushing cycle.
Freeze sec	0...999 seconds, extra freeze time of output signal after a flushing cycle.
Relay	"-", "1", "2", "Along 1", or "Along 2". Select relay to operate solenoid for flush cycle if this sensor is a master with its own relay, or relay used by master if this sensor is a slave. These are the same relays used for " Alarm relay " below.
Next time	The next scheduled cleaning time. Pushing \leftarrow on this line will set the time to current time and start a cleaning cycle. This could be used to test the "Flush" cycle.

Menu "Scale / Alarm"

Submenu	Description
Max	Measured value corresponding to 100 %, equal to 20 mA output signal (or 4 mA if 20-4 mA is used).
Min	Measured value corresponding to 0 %, equal to 4 mA output signal (or 20 mA if 20-4 mA is used).
Hi-Alarm	Level that activates an alarm when exceeded, 0 = not in use.
Low-Alarm	Level that activates an alarm when underpassed, 0 = not in use.
Alarm Relay	"-", "1", "2" or "1 and 2". Check that the relay is not being used for cleaning.

Menu "System"

Submenu	Description
Type	Type of sensor, read only.
Serial	Serial number of the sensor, read only.
SoftW	Software version of the sensor, read only.
Press \leftarrow to go to "info" read only menu. This menu is for KROHNE internal use.	
Info	
MS 1 mV	Millivolt value for the first calibration point.
MS 2 mV	Millivolt value for the second calibration point.
pH 1	pH for the first calibration point.
pH 2	pH for the second calibration point.
RV 0 mV	Raw value for 0 mV.
RV 200 mV	Raw value for 200 mV.
Ch1	Raw value.
MS mV	Electrode output in millivolt.
pH	Current measure value.
Samp/s	Number of samples per second.
Service	Not accessible for users.

5.2.2 Menu for PAS 2000 ORP

Menu "Settings"

Submenu	Description
Tag	Name of the sensor (10 characters) shown in the main display.
I-Time	Integration time or dampening - can be set up to 999 seconds. Normal value is 5-10 seconds.
Analog	"None", "Out1", "Out2", "Out3", "Out4", "Out1+2" or "Out3+4". Pick which analog output(s) to be used with sensor.

Menu "Calibrate"

Submenu	Description
Adjust	"No", "Reset" or "Set". Automatic offset adjustment.
Offset	Offset for the electrode.
@Buffer	Buffer used for adjustment, saved during the automatic offset adjustment.
ORP mV	Current reading.
New electr.	Date when electrode was last changed. Push \leftarrow to edit the date, then \leftarrow again to store it.

Menu "Cleaning"

Submenu	Description
	Press \leftarrow to go to the cleaning program
Cleaner	"None", "Flush" or "Brush". Do not select "Brush" since this does not exist for this sensor.
Interval min	0...999 minutes, time between cleaning cycles.
Length sec	0...999 seconds, duration of flushing cycle.
Freeze sec	0...999 seconds, extra freeze time of output signal after a flushing cycle.
Relay	"-", "1", "2", "Along 1" or "Along 2". Select relay to operate solenoid for flush cycle if this sensor is a master with its own relay, or relay used by master if this sensor is a slave. These are the same relays used for " Alarm relay " below.
Next time	The next scheduled cleaning time. Pushing \leftarrow on this line will set the time to current time and start a cleaning cycle. This could be used to test the "Flush" cycle.

Menu "Scale / Alarm"

Submenu	Description
Max	Measured value corresponding to 100 %, equal to 20 mA output signal (or 4 mA if 20-4 mA is used).
Min	Measured value corresponding to 0 %, equal to 4 mA output signal (or 20 mA if 20-4 mA is used).
Hi-Alarm	Level that activates an alarm when exceeded, 0 = not in use.
Low-Alarm	Level that activates an alarm when underpassed, 0 = not in use.
Alarm Relay	"-", "1", "2" or "1 and 2". Check that the relay is not being used for cleaning.

Menu "System"

Submenu	Description
Type	Type of sensor, read only.
Serial	Serial number of the sensor, read only.
SoftW	Software version of the sensor, read only.
	Press \leftarrow to go to "info" read only menu. This menu is for KROHNE internal use.
Info	
RV 0 mV	Raw value for 0 mV.
RV 1000 mV	Raw value for 1000 mV.
Ch1	Raw value.
ORP mV	Current reading in millivolt.
Samp/s	Number of samples per second.
Service	Not accessible for users.

5.3 Calibration

The sensor is shipped pre-calibrated, but since all electrodes are different, the sensor must be calibrated with its electrode to give a good measurement. The electrode degrades by time and calibrations shall be done regularly following a maintenance schedule.

The time between calibrations varies with the application, it is usually between one and ten weeks. It is important that the sensor has been switched on for about 30 minutes prior to the calibration in order to stabilize.

5.3.1 Calibrating pH

For a pH calibration there are two alternatives: smart or manual. Irrespective of the type of calibration you chose, you need two pH buffers which both have a common, known temperature.

For a smart calibration you need two different buffer solutions with pH 4.00, 7.00, or 10.00. For a manual calibration, two different buffer solutions can be used irrespective of the buffer value.

Remove the sensor and, if necessary the electrode as well, but make sure that the electrode is still connected to the signal amplifier. Make sure that you have at least 2 standard buffers available with pH 4.00, 7.00 or 10.00 of a known temperature (it is best to pour the buffers into plastic cups). Now do the steps that follow:



- Enter the sensor menu. The output is frozen when the menu is opened.
- Open the "Calibrate" menu, select "Calibrate", then "Smart" or "Manual" and press \leftarrow .
- A window pops up and asks for the buffer temperature. Enter the temperature and press \leftarrow .
- MAC 080 will say "Put the electrode in buffer 1". Spray the electrode using clean water, then immerse it in the first buffer, and press \leftarrow .
- The text will say "Waiting for stable signal xxx,x mV" (xxx,x is the millivolt signal from the electrode). By pressing \leftarrow you can select to abort the calibration or to accept the value shown.
- If smart calibration is used and MAC 080 recognizes the buffer, MAC 080 will suggest a pH value showing the text "Accept smart calibration pH X.X". You can choose to accept the value or to change it manually.
- If manual calibration is used MAC 080 will always ask for the value of the buffer, enter the value and press \leftarrow .
- MAC 080 will now tell you "Put the electrode in buffer 2". Spray the electrode using clean water, then immerse it in the second buffer, and press \leftarrow .
- The text will say "Waiting for stable signal xxx,x mV" (xxx,x is the millivolt signal from the electrode). By pressing \leftarrow you can select to abort the calibration or to accept the value shown.
- If smart calibration is used and MAC 080 recognizes the buffer, MAC 080 will suggest a pH value showing the text "Accept smart calibration pH X.X". You can choose to accept the value or to change it manually.
- If manual calibration is used MAC 080 will always ask for the value of the buffer, enter the value and press \leftarrow .
- The second buffer is not accepted if it is less than 1 pH from buffer 1, if so the second calibration will be repeated.
- When the calibration is finished the slope is shown in the display ("Slope XX%"). This gives an indication of the shape of the electrode. A good electrode has a slope between 93 and 102 %.
- Press \leftarrow to finish the calibration.

5.3.2 Adjusting ORP

The ORP sensor is not re-calibrated, an offset adjustment is done instead. The offset adjustment can be done in two ways: automatic or manual. Irrespective of the way you chose, you need a buffer with a known potential.

Remove the sensor and, if necessary the electrode as well, but make sure that the electrode is still connected to the signal amplifier. Wipe clean the electrode before adjustment. Now do the steps that follow:



- Spray the electrode using clean water, then immerse it in the first buffer, and wait for a stable reading.
- Enter the sensor menu. The output is frozen when the menu is opened.
- Open the "Calibrate" menu, then select "Adjust", choose "Set" and press ←.
- A window pops up asking for the ORP potential. Enter it and then press ←. MAC 080 will calculate the difference and use it as offset.

5.4 Scaling

The **Scale / Alarm** menu (see the OPTISENS MAC 080 manual) allows the user to set the high and low boundaries for a 4...20 mA output signal. In addition, this menu allows the user to set high and low alarm values to switch a relay when solids have reached critical points.

Max	sets the 20 mA point output
Min	sets the 4 mA point output (may be negative for special applications)
Hi-Alarm	sets the high alarm set point; the value zero inactivates the alarm
Low-Alarm	sets the low alarm set point; the value zero inactivates the alarm

6.1 Maintenance

PAS 2000 sensors are easy to maintain. An electrode maintenance schedule should be kept, listing when it is removed and cleaned. When this is done, the electrode should be checked against a known buffer solution. If the control value does not match, a re-calibration should be made.

Regularly check that the sensor does not get damp or wet inside during cleaning and other activities. Also check that the electrode is correctly mounted in its holder to avoid leaking.



CAUTION!

Use distilled water for cleaning, otherwise the calibration and in worst case the total life time of the electrode might be compromised.

6.1.1 Broken electrode

Lightning or static discharges during thunder storms may cause damage to the electrode, and could also damage the signal amplifier. The electrode is the most exposed point since it is in direct contact with the water and, consequently, the ground connection for a discharge.

Physical damage to the electrode usually makes measuring impossible. Make sure that neither electrode nor cable is damaged.

6.1.2 Error messages

Display text	Explanation	Cause	Solution
Unkown buffer	The smart calibration does not recognize the current buffer from the signal of the electrode.	Unknown buffers have been used.	Use standard buffers 4.00, 7.00 and 10.00.
		Broken sensor, damaged electronic components or bad cable connection.	Check or reseal cable connection. Inspect electrode and exchange it if damaged.
Same buffer	During calibration the PAS 2000 pH does not perceive a difference of buffers.	Same buffers have been used.	Make sure that you use two different buffers during calibration.
		The electrode or the electronic components in the sensor may be broken.	Inspect electrode and exchange it if damaged.

6.1.3 Incorrect measurements

Problem	Solution
Dirty electrode	Clean with distilled water
Insufficient or poor reference solution in the electrode	Refill/change reference solution (only for refillable electrodes)
Change of "slope" due to age	Recalibration
Old electrode which gives slope <93 %	Change electrode

6.1.4 Cleaning of the flushing nozzle

If the flushing nozzle becomes plugged, it can usually be cleaned by back flushing it with clean water. Before attempting to backflush, close the valve for the flush water source and disconnect the sensor flushing hose from the solenoid valve. Then, place a 12 mm hose over the flush nozzle and carefully open the water valve.

The pressure should clear the line of solids. If backflushing does not work initially, try cleaning the flushing nozzle with a needle. Try backflushing the nozzle again as described above until clean water comes out at the solenoid valve end of the hose.

6.2 Cleaning

The sensor is equipped with a flushing nozzle. The nozzle is used to direct the cleaning liquid supplied through a 6 mm hose that is mounted along the sensor housing to flush the electrode. A solenoid valve that is wired to a relay in the MAC 080 converter controls the air or liquid (see handbook OPTISENS MAC 080).

Compressed air is recommended for most applications.



CAUTION!

For PAS 2000 submersible sensor the highest allowed flushing pressure is 6 bar / 87 psi. When using air, 2 bar / 29 psi is usually sufficient.



NOTE!

Pay attention to the requirements for protection against backflow, according to the EN 1717 standard for drinking water devices. If possible, use plant reuse water or effluent water for cleaning.

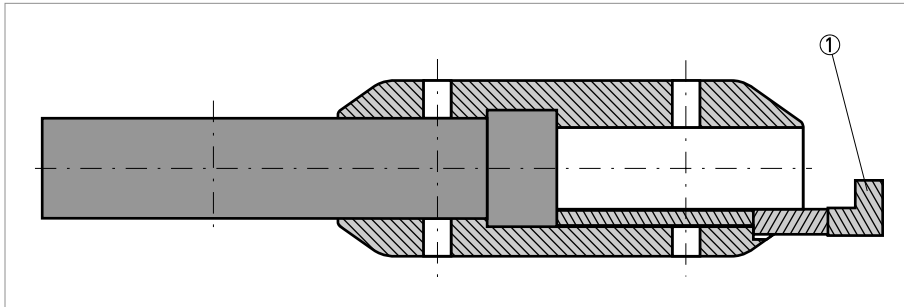

Figure 6-1: Flushing system

- ① Flush nozzle for automatic cleaning



NOTE!

*In order to clean the sensor, flushing must be activated in the **Settings** menu in the **MAC 080** converter*

There are two different ways of cleaning a sensor: The sensor can either be cleaned as a master or as a slave. Both options are described in the following instructions.



Cleaning the sensor as a master (sensor has its own relay)

- Select the sensor in the main menu by using ↑ or ↓.
- Press ← for approximately five seconds to enter the sensor menu.
- Use ↑ or ↓ to select **Cleaning** and press ←.
- In the **Cleaning** submenu, select **Cleaner** and set it to **Flush**.
- Then specify the cleaning interval in minutes (**Interval min**) and the flush time in seconds (**Lenght sec**).
- Specify the relay to be used according to the wiring inside the MAC 080 converter. For example, if the solenoid is wired to relay #1, set **Relay** to **#1** for flushing.
- For sensors configured as masters, **Next time** displays the next time flush will be activated. Pushing ← will set it to current time and thus start cleaning.
- If needed, specify the extra freeze time in seconds (**Freeze sec**).



Cleaning the sensor as a slave (along with another sensor)

- Select the sensor in the main menu by using ↑ or ↓.
- Press ← for approximately five seconds to enter the sensor menu.
- Use ↑ or ↓ to select **Cleaning** and press ←.
- The parameters **Cleaner**, **Interval min** and **Lenght sec** in the **Cleaning** submenu are set for the sensor being the master.
- Set **Relay** to **Along #1** or **Along #2** depending on what relay the master sensor uses.
- If needed, specify the extra freeze time in seconds (**Freeze sec**).

6.3 Spare parts availability

The manufacturer adheres to the basic principle that operational spare parts for each device or each important accessory part will be kept available for a period of 10 (ten) years after delivery of the last production run for that device.

Operational spare parts are defined as parts that are subject to faults in normal operation.

6.4 Availability of services

The manufacturer offers a range of services to support the customer after expiration of the warranty. These include repair, technical support and training.



NOTE!

For more precise information, please contact your local representative.

6.5 Returning the device to the manufacturer

6.5.1 General information

This device has been carefully manufactured and tested. If installed and operated in accordance with these operating instructions, it will rarely present any problems.



CAUTION!

Should you nevertheless need to return a device for inspection or repair, please pay strict attention to the following points:

- *Due to statutory regulations on environmental protection and safeguarding the health and safety of our personnel, manufacturer may only handle, test and repair returned devices that have been in contact with products without risk to personnel and environment.*
- *This means that the manufacturer can only service this device if it is accompanied by the following certificate (see next section) confirming that the device is safe to handle.*



CAUTION!

If the device has been operated with toxic, caustic, flammable or water-endangering products, you are kindly requested:

- *to check and ensure, if necessary by rinsing or neutralizing, that all cavities are free from such dangerous substances,*
- *to enclose a certificate with the device confirming that is safe to handle and stating the product used.*

6.5.2 Form (for copying) to accompany a returned device

Company:		Address:	
Department:		Name:	
Tel. no.:		Fax no.:	
Manufacturer's order no. or serial no.:			
The device has been operated with the following medium:			
This medium is:	water-hazardous		
	toxic		
	caustic		
	flammable		
	We checked that all cavities in the device are free from such substances.		
	We have flushed out and neutralized all cavities in the device.		
We hereby confirm that there is no risk to persons or the environment through any residual media contained in the device when it is returned.			
Date:		Signature:	
Stamp:			

6.6 Disposal

**CAUTION!**

Disposal must be carried out in accordance with legislation applicable in your country.

7.1 Measuring principle

The pH value is normally measured with an electrode where pH is expressed as a function of voltage. Today's electrodes often contain both a measuring electrode and a reference electrode, which in combination provide a voltage in linear proportion to the pH value. Electrodes internally combined with a reference and measuring cell are divided into two categories: gel electrodes and refillable electrodes. The gel electrode is the simpler and less expensive type. There are a number of different types of refillable electrodes for different applications, each with different internal solutions that are to be added at regular intervals. KROHNE provides gel-filled glass electrodes.

To compensate for the temperature dependence of the electrode, the temperature of the media is measured by the transmitter and compensated automatically via the MAC 080 software. The temperature can also be read in the MAC 080 converter and used as secondary value when a transmitter is configured to use two analogue outputs.

**NOTE!**

The build in temperature measurement is not a precision measurement, but shall be seen as an indication.

The temperature compensation can also be set manually to a fixed value via the MAC 080 menu. All settings are made in the MAC 080 converter using a self-instructing menu controlled by just three keys. The output signal is frozen when you switch to menu mode so that the output signal will not change during procedures such a re-calibration.

The MAC 080 has two 4-20 mA outputs (extendable to four), and relay outputs for alarm and cleaning of the electrode. The current pH/mV values and the temperature measurement of the active sensor are continuously displayed in the MAC 080 display. Maximum, minimum and average values for the last 24 hours can be obtained by pressing two buttons.

7.2 Data table

	OPTISENS PAS 2000 pH	OPTISENS PAS 2000 ORP
--	----------------------	-----------------------

Measuring system

Measuring principle	Potentiometric measurement using combination electrodes	Potentiometric measurement using combination electrodes
Field of application	Continuous measurement of pH in waste water applications	Continuous measurement of ORP in waste water applications
Modular design	A typical measuring system consists of:	A typical measuring system consists of:
	MAC 080 Multiparameter Converter	MAC 080 Multiparameter Converter
	1 (or up to 4) OPTISENS 2000 Sensors	1 (or up to 4) OPTISENS 2000 Sensors
	Solenoid valves for flushing	Solenoid valves for flushing
	MAA 2000 mounting assemblies	MAA 2000 mounting assemblies
Measuring accuracy	± 1.5 % FS (Full scale)	± 1.5 % FS (Full scale)
Measuring range	0...14 pH	-1500...+1500 mV (ORP)

Operating conditions

Process temperature	0...60°C / 32...140°F	0...60°C / 32...140°F
Max. immersion depth	0.8 m / 2.6 ft	0.8 m / 2.6 ft
Calibration	Two point calibration (smart or manual) using two buffer solutions	Offset calibration (automatic or manual) using clean water and one buffer solution

Installation conditions

PAS 2000 + MAA 2000 Telescopic rod for immersion into basins	The telescopic rod can be fixed to the handrail using a flexible spring loaded mounting bracket
	Fully extended: 2.7 m / 8.9 ft
	Mounting bracket for:
	- Round handrails $\varnothing = 32...50$ mm / 1.3...2" - Square cross-sections 28...42 mm / 1.1...1.7"
PAS 2000 + MAA 2000 Slide rail for side wall mounting	Installation on the side wall of basins; retractable holder with adjustable stop
Flushing	With filtered air or clean water
	Pressure: 2...6 bar / 29...87 psi
	Hose: 1/4" external diameter; length: 10 m / 32.8 ft
	Solenoid valve: available in 230 V and 117 V versions; up to 2 sensors can be connected to one solenoid valve
Process connection	Submerged in open channels/basins

	OPTISENS PAS 2000 pH	OPTISENS PAS 2000 ORP
--	----------------------	-----------------------

Materials

Enclosure	316SS	316SS
Cable feed through	PVC	PVC
Sensor holder for telescopic rod	POM	POM
Connection cable	5-pin M 12 contact; fixed on sensor side, shielded; 10 m / 32.8 ft long; insulation: Hytrel	5-pin M 12 contact; fixed on sensor side, shielded; 10 m / 32.8 ft long; insulation: Hytrel
Flush hose	PE	PE
Electrode	Design: Combination electrode 12 mm / 0.47"; Length: 120 mm / 4.72"	Design: Combination electrode 12 mm / 0.47"; Length: 120 mm / 4.72"
	PG13.5 threaded cap	PG13.5 threaded cap
	KCL-Gel	KCL-Gel
	Connector: KOAX	Connector: KOAX

Approvals

Protection class	IP65 (Nema 4x)
Approval mark	CE
EMC (89/336/EEC)	Electromagnetic compatibility (EMC) in accordance with:
	EN 61000-6-4:2001 Emission standard for industrial environments
	EN 61000-6-2:2001 Immunity for industrial environments
Low Voltage Directive (89/336/EEC)	Safety requirements for electrical equipment for measurement, control, and laboratory use in accordance with EN 61010-1:2001

7.3 Dimensions & Weight

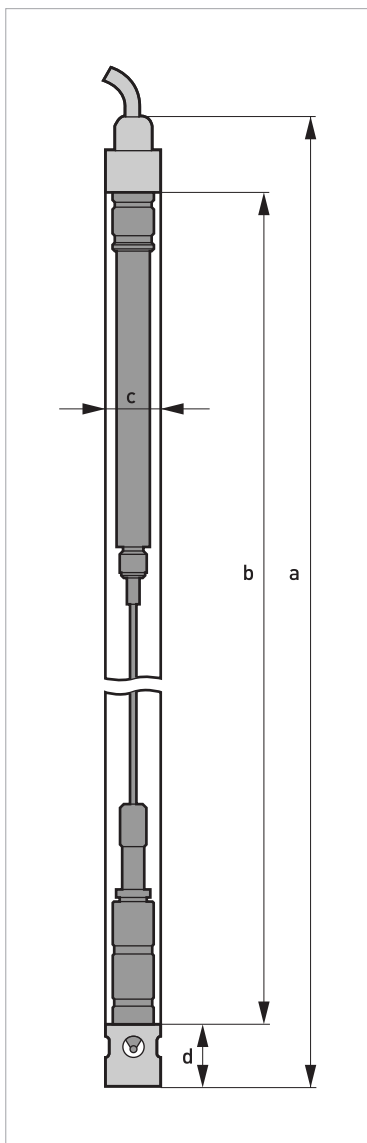

	Dimensions [mm]	Dimensions [inches]
a	1085	42.7
b	1000	39.4
c	Ø 28	Ø 1.1
d	35	1.4

	Weight [kg]	Weight [lbs]
PAS 2000 length 1000 mm / 39.4"	1.8	4

MAA 2000 sensor holder and telescopic rod

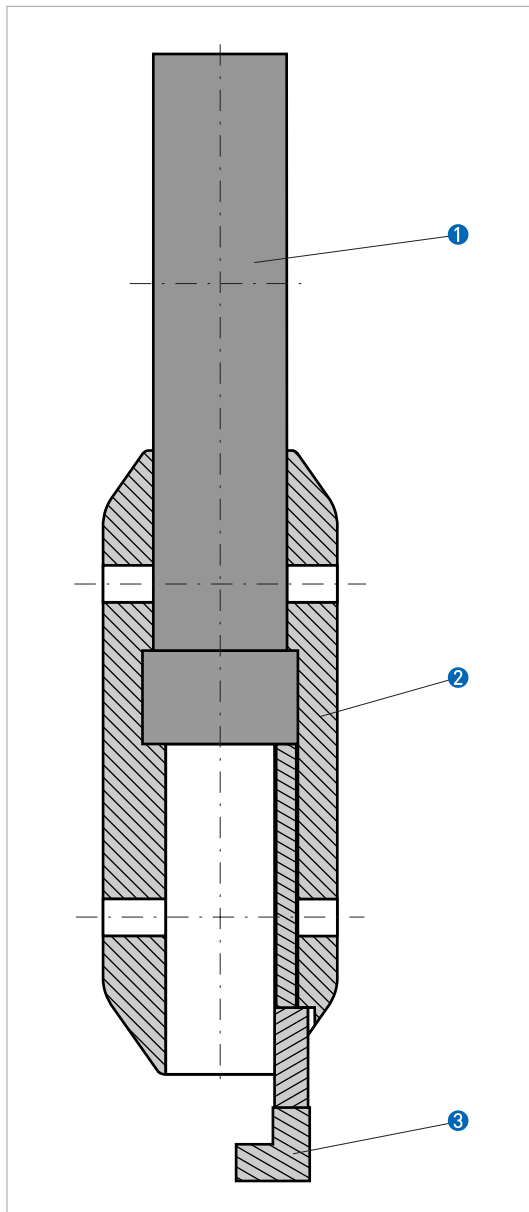

- ① Flexible telescopic rod
- ② Large diameter sensor holder
- ③ Flush nozzle for automatic cleaning

	Weight [kg]	Weight [lbs]
MAA 2000 sensor holder	0.5	1.1

8.1 pH as a function of mV

The pH-value is the negative logarithm of the hydrogen ion concentration, and it is directly related to the proportion of hydrogen ions H^+ to hydroxide ions OH^- in the media. The pH-electrode measures excess or deficit of the hydrogen ions and gives a proportional millivolt signal as output. The signal is 59.16 mV per 1 pH at 77°F. In clean water there is a total balance between hydrogen ions and hydroxide ions, the output from the electrode is 0.0 mV and pH is 7. The millivolt signal is measured by PAS 2000 pH and the corresponding pH is calculated in MAC 080.

mV	pH	H^+ ions, mol/l	OH^- ions, mol/l	Example
414	0	1	0.000000000000001	
355	1	0.1	0.000000000000001	
296	2	0.01	0.000000000000001	Coca Cola
237	3	0.001	0.000000000000001	
177	4	0.0001	0.000000000000001	Orange juice
118	5	0.00001	0.000000000000001	
59	6	0.000001	0.000000000000001	Milk
0	7	0.0000001	0.000000000000001	Clean water
-59	8	0.00000001	0.0000001	Blood
-118	9	0.000000001	0.000001	
-177	10	0.0000000001	0.00001	
-237	11	0.00000000001	0.001	
-296	12	0.000000000001	0.01	
-355	13	0.0000000000001	0.1	
-414	14	0.000000000000001	1	Sulfa

8.2 pH temperature dependency

The output from a pH-electrode varies with the temperature in a predictable way. The size of the variation depends on both the temperature and the pH being measured.

°C	°F	pH	pH	pH	pH	pH	pH	pH	pH	pH	pH	pH	pH
5	41	2.30	3.24	4.18	5.12	6.06	7.00	8.06	9.12	10.18	11.24	12.30	13.36
15	59	2.15	3.12	4.09	5.06	6.03	7.00	8.03	9.06	10.09	11.12	12.15	13.18
25	77	2.00	3.00	4.00	5.00	6.00	7.00	8.00	9.00	10.00	11.00	12.00	13.00
35	95	1.85	2.88	3.91	4.94	5.97	7.00	7.97	8.94	9.91	10.88	11.85	12.82
45	113	1.70	2.76	3.82	4.88	5.94	7.00	7.94	8.88	9.82	10.76	11.70	12.64
55	131	1.55	2.64	3.73	4.82	5.91	7.00	7.91	8.82	9.73	10.64	11.55	12.46
65	149	1.40	2.52	3.64	4.76	5.88	7.00	7.88	8.76	9.64	10.52	11.40	12.28
75	167	1.25	2.40	3.55	4.70	5.85	7.00	7.85	8.70	9.55	10.40	11.25	12.10
85	185	1.10	2.28	3.46	4.64	5.82	7.00	7.82	8.64	9.46	10.28	11.10	11.92
95	203	0.95	2.16	3.37	4.58	5.79	7.00	7.79	8.58	9.37	10.16	10.95	11.74

At pH 7 or 78°F the temperature error is zero. If temperature or pH changes the temperature error is calculated using the following formula: $0.03 \text{ pH-difference} / \text{pH} / 10^\circ\text{C}$. PAS 2000 pH has a built in compensation for the temperature error provided that the correct temperature of calibration buffers and measured media is entered.

8.3 Support information form

Before calling the customer support, please collect the information in this form and have it at hand.

Company:		Name:	
Phone:		E-mail:	
Sensor type:		Position / Tag:	
First go to the converter menu by pressing ↑ and ← simultaneously for five seconds. Then select System and press ←. Write down the following information.			
Version:			
Serial:			
Box temp:			
Leave the converter menu by pressing ↑ and ← simultaneously. Use ↑ and ↓ to select the sensor in the main display. Go to the sensor menu by pressing ← for five seconds. Then select System and press ←. Write down the following information.			
Type:		SoftW:	
Serial:			
Select Info , then press ← to go to the Info menu.			
MS 1 mV ①		MS 2 mV ①	
pH 1 ①		pH 2 ①	
RV 0 mV		RV 200 mV ①	
RV 1000 mV ②		Ch1	
MS mV ①		ORP mV ②	
pH ①			
Leave the menu by pressing ↑ and ← simultaneously.			

① Only for PAS 2000 ph

② Only for PAS 2000 ORP

8.4 Setup information form

This form can be used to document the setup of the sensor.

Sensor type	
Position / Tag	
In the System submenu of the sensor menu the following information can be collected:	
Serial	
SoftW	
In the Settings submenu of the sensor menu the following parameters can be set:	
I-time	
Decimals ①	
Analog	
In the Cleaning submenu of the sensor menu the following parameters can be set:	
Cleaner	
Cleaning interval	
Cleaning length	
Cleaning relay	
In the Scale / Alarm submenu of the sensor menu the following parameters can be set:	
Max	
Min	
High alarm	
Low alarm	
Alarm relay	
Leave the menu by pressing ↑ and ← simultaneously.	

① Only for PAS 2000 pH

KROHNE measuring technology - Product overview

- Electromagnetic flowmeters
- Variable area flowmeters
- Mass flowmeters
- Ultrasonic flowmeters
- Vortex flowmeters
- Flow controllers
- Level measuring instruments
- Temperature measuring instruments
- Pressure measuring instruments
- Analysis
- Oil and gas industry

Addresses:

Germany

Northern sales office

KROHNE Messtechnik GmbH & Co. KG
Bremer Str. 133
D-21073 Hamburg
Phone: +49 (0)40 767 3340
Fax: +49 (0)40 767 33412
nord@krohne.com
ZIP code: 10000 - 29999, 49000 - 49999

Western and middle sales office

KROHNE Messtechnik GmbH & Co. KG
Ludwig-Krohne-Straße
D-47058 Duisburg
Phone: +49 (0)203 301 4416
Fax: +49 (0)203 301 10416
west@krohne.com
ZIP code: 30000 - 34999, 37000 - 48000, 50000 - 53999, 57000 - 59999, 98000 - 99999

Southern sales office

KROHNE Messtechnik GmbH & Co. KG
Landsberger Str. 392
D-81241 Munich
Phone: +49 (0)89 121 5620
Fax: +49 (0)89 129 6190
sued@krohne.com
ZIP code: 0 - 9999, 80000 - 89999, 90000 - 97999

Southwestern sales office

KROHNE Messtechnik GmbH & Co. KG
Rüdesheimer Str. 40
D-65239 Hochheim/Main
Phone: +49(0)6146) 827 30
Fax: +49 (0)6146 827 312
rhein-main@krohne.com
ZIP code: 35000 - 36999, 54000 - 56999, 60000 - 79999

Instrumentation and control equipment catalog

TABLAR Messtechnik GmbH
Ludwig-Krohne-Str. 5
D-47058 Duisburg
Phone: +49 (0)2 03 305 880
Fax: +49 (0)2 03 305 888
kontakt@tablar.de; www.tablar.de

KROHNE sales companies

International

Australia

KROHNE Australia Pty Ltd
Quantum Business Park 10/287
Victoria Rd Rydalmere NSW 2116
Phone: +61 2 8846 1700
Fax: +61 2 8846 1755
krohne@krohne.com.au

Austria

KROHNE Gesellschaft m.b.H.
Modecenterstraße 14
A-1030 Vienna
Phone: +43 (0)1/203 45 32
Fax: +43 (0)1/203 45 32 99
info@krohne.at

Belgium

KROHNE Belgium N.V.
Brusselstraat 320
B-1702 Groot Bijgaarden
Phone: +32 (0)2 4 66 00 10
Fax: +32 (0)2 4 66 08 00
krohne@krohne.be

Brazil

KROHNE Conat Controles
Automaticos Ltda.
Estrada Das Águas Espraiadas, 230
C.P. 56 06835 - 080 EMBU - SP
Phone: +55 (0)11-4785-2700
Fax: +55 (0)11 4785-2768
conat@conat.com.br

China

KROHNE Measurement Instruments
(Shanghai) Co. Ltd., [KMIC]
9th Floor, Puyuan Science Park,
Building A
396 Guilin Road
Shanghai 200233
Tel.: +86 (021) 6470 5656
Fax: +86 (021) 6451 6408
info@krohne-asia.com

Czech Republic

Krohne CZ, spol. s r.o.
Sobiesická 156
63800 Brno
Phone: +420 (0)545.242 627
Fax: +420 (0)545 220 093
brno@krohne.cz

France

KROHNE S.A.S.
Les Ors BP 98
F-26103 ROMANS Cedex
Phone: +33 (0)4 75 05 44 00
Fax: +33 (0)4 75 05 00 48
info@krohne.fr

Great Britain

KROHNE Ltd.
Rutherford Drive
Park Farm Industrial Estate
Wellingborough
Northants NN8 6AE
Phone: +44 (0)19 33 408 500
Fax: +44 (0)19 33 408 501
info@krohne.co.uk

CIS

Kanex KROHNE Engineering AG
Business Centre "POLLARS", office
164
Derbenevskaya nab., 11-B
113114 Moscow/Russia
Tel. / Fax: +7 (0)495 913-68-41
Tel. / Fax: +7 (0)495 913-68-42
Tel. / Fax: +7 (0)495 913-68-43
Tel. / Fax: +7 (0)495 913-68-44
krohne@krohne.ru

India

Krohne Marshall Ltd.
A-34/35, M.I.D.C. Industrial Area,
H-Block
Pimpri Poona 411018
Phone: +91 (0)202 744 2020
Fax: +91 (0)202 744 2020
pcu@vsnl.net

Iran

KROHNE Liaison Office
North Sohrevardi Ave. 26,
Sarmad St., Apt. #9
Tehran 15539
Phone: +9821 8874 5973
Fax: +9821 8850 1268
krohne@krohneiran.com

Italy

KROHNE Italia Srl.
Via V. Monti 75
I-20145 Milan
Phone: +39 02 4300 661
Fax: +39 02 4300 6666
info@krohne.it

Korea

KROHNE Korea
Room 508 Miwon Bldg 43
Yoido-Dong Youngdeungpo-Ku
Seoul, Korea
Phone: 00-82-2-782-1900
Fax: 00-82-2-780-1749
mail@krohne.co.kr

Netherlands

KROHNE Nederland B.V.
Kerkeplaat 14
NL-3313 LC Dordrecht
Phone: +31 (0)78 630 6200
Fax: +31 (0)78 630 6405
Service Direct: +31 (0)78 630 6222
info@krohne.nl

Norway

KROHNE Norway A.S.
Ekholtveien 114
NO-1521 Moss
Phone: +47 (0)69 264 860
Fax: +47 (0)69 267 333
postmaster@krohne.no

Poland

KROHNE Polska Sp.z.o.o.
ul. Stary Rynek Oliwski 8a
80-324 Gdansk
Phone: +48 (0)58 520 9211
Fax: +48 (0)58 520 9212
info@krohne.pl

Switzerland

KROHNE AG
Uferstr. 90
CH-4019 Basel
Phone: +41 (0)61 638 30 30
Fax: +41 (0)61 638 30 40
info@krohne.ch

Singapore

Tokyo Keiso - KROHNE (Singapore)
Pte. Ltd.
14, International Business Park,
Jurong East
Chiyoda Building, #01-01/02
Singapore 609922
Phone: (65) 6567 4548
Fax: (65) 6567 9874
tks@tokyokeiso-krohne.com.sg

Republic of South Africa

KROHNE Pty. Ltd.
Bushbock Close
Corporate Park South
Midrand, Gauteng
P.O. Box 2069
Midrand, 1685
Tel.: +27 (0)11 314 1391
Fax: +27 (0)11 314 1681
midrand@krohne.co.za

Spain

I.I. KROHNE IBERIA, S.r.l.
Poligono Industrial Nilo
Calle Brasil, nº. 5
28806 Alcalá de Henares Madrid
Phone: +34 (0)91 883 2152
Fax: +34 (0)91 883 4854
krohne@krohne.es

USA

KROHNE, Inc.
7 Dearborn Road
Peabody, MA 01960
Phone: +1 (800) FLOWING
Phone: +1 (978) 535 6060 (in MA)
info@krohne.com

Representatives

Algeria
Argentina
Cameroun
Canada
Chile
Columbia
Croatia
Denmark
Ecuador
Egypt
Finland
Gabon
Ghana
Greece
Hong Kong
Hungary
Indonesia
Iran
Ireland
Israel
Ivory Coast
Japan
Jordan
Kuwait
Libya
Lithuania
Malaysia
Mauritius
Mexico
Morocco
New Zealand
Peru
Portugal
Romania
Saudi Arabia
Senegal
Slovakia
Slovenia
Sweden
Taiwan
Thailand
Tunisia
Turkey
Venezuela
Yugoslavia

Other countries

KROHNE Messtechnik GmbH & Co. KG
Ludwig-Krohne-Str. 5
D-47058 Duisburg
Phone: +49 (0)203 301 0
Fax: +49 (0)203 301 389
export@krohne.com