

OPTISONIC 8300 Handbook

Ultrasonic flowmeter
for high temperature gas and steam

All rights reserved. It is prohibited to reproduce this documentation, or any part thereof, without the prior written authorisation of KROHNE Messtechnik GmbH.

Subject to change without notice.

Copyright 2014 by
KROHNE Messtechnik GmbH - Ludwig-Krohne-Str. 5 - 47058 Duisburg (Germany)

1	Safety instructions	7
1.1	Intended use	7
1.2	Certification	8
1.3	Safety instructions from the manufacturer	9
1.3.1	Copyright and data protection	9
1.3.2	Disclaimer	9
1.3.3	Product liability and warranty	10
1.3.4	Information concerning the documentation	10
1.3.5	Warnings and symbols used	11
1.4	Safety instructions for the operator	11
2	Device description	12
2.1	Scope of delivery	12
2.2	Device description	13
2.3	Field housing	14
2.4	Nameplates	15
2.4.1	Example of nameplate for the measuring sensor	15
2.4.2	Examples of nameplates on the signal converter (field version)	15
3	Installation	17
3.1	General notes on installation	17
3.2	Storage	17
3.3	Transport	17
3.4	Installation requirements signal converter	18
3.5	Vibration	18
3.6	General requirements sensor	19
3.6.1	Inlet and outlet	19
3.6.2	T-section	19
3.6.3	Mounting position	20
3.6.4	Flange deviation	20
3.6.5	Control valve	21
3.6.6	Thermal insulation	21
3.7	Mounting the field housing, remote version	22
3.7.1	Pipe mounting	22
3.7.2	Wall mounting	23
3.7.3	Turning the display of the field housing version	24
4	Electrical connections	25
4.1	Safety instructions	25
4.2	Signal cable OPTISONIC 8000 Sensor	25
4.3	Signal cable converter	26
4.4	Power supply	27
4.5	Inputs and outputs, overview	28
4.5.1	Combinations of the inputs/outputs (I/Os)	28
4.5.2	Description of the CG number	29
4.5.3	Alterable input/output versions	30

4.6	Description of the inputs and outputs	31
4.6.1	Current output	31
4.6.2	Pulse and frequency output	32
4.6.3	Status output and limit switch	33
4.6.4	Control input	34
4.7	Electrical connection of the inputs and outputs	35
4.7.1	Field housing, electrical connection of the inputs and outputs	35
4.7.2	Laying electrical cables correctly.....	36
4.8	Connection diagrams of inputs and outputs	37
4.8.1	Important notes.....	37
4.8.2	Description of the electrical symbols.....	38
4.8.3	Basic inputs/outputs	39
4.8.4	Modular inputs/outputs and bus systems	42
4.8.5	Ex i inputs/outputs	50
4.8.6	HART® connection	54
5	Start-up	56
<hr/>		
5.1	Switching on the power	56
5.2	Starting the signal converter	56
6	Operation	57
<hr/>		
6.1	Display and operating elements	57
6.1.1	Display in measuring mode with 2 or 3 measured values	59
6.1.2	Display for selection of sub-menu and functions, 3 lines.....	59
6.1.3	Display when setting parameters, 4 lines	60
6.1.4	Display when previewing parameters, 4 lines.....	60
6.1.5	Using an IR interface (option)	61
6.2	Menu overview	62
6.3	Function tables	65
6.3.1	Menu A, quick setup.....	65
6.3.2	Menu B, test	66
6.3.3	Menu C, setup	68
6.3.4	Set free units.....	85
6.4	Setup of flow measurement	86
6.4.1	Function 1: Volume flow calculation	89
6.4.2	Function 2: Correction of inner diameter based on static temperature and pressure input..	89
6.4.3	Function 3: Correction of inner diameter based on measured temperature and pressure	89
6.4.4	Function 4: Calculation of steam density and mass flow.....	90
6.4.5	Function 5: Reynolds linearisation	90
6.4.6	Function 6: Velocity of Sound monitoring.....	91
6.5	Description of functions	92
6.5.1	Reset counter in the menu "quick setup"	92
6.5.2	Deleting error messages in the menu "quick setup".....	92
6.6	Error messages	93

7 Service	96
7.1 Spare parts availability	96
7.2 Availability of services	96
7.3 Returning the device to the manufacturer	96
7.3.1 General information	96
7.3.2 Form (for copying) to accompany a returned device	97
7.4 Disposal	97
8 Technical data	98
8.1 Measuring principle	98
8.2 Technical data	99
8.3 Dimensions and weights	109
8.3.1 Flow sensor	109
8.3.2 Converter housing	110
8.3.3 Mounting plate, field housing	110
9 Description of HART interface	111
9.1 General description	111
9.2 Software history	111
9.3 Connection variants	112
9.3.1 Point-to-Point connection - analogue / digital mode	113
9.3.2 Multi-Drop connection (2-wire connection)	114
9.3.3 Multi-Drop connection (3-wire connection)	115
9.4 Inputs/outputs and HART [®] dynamic variables and device variables	116
9.5 Remote operation	117
9.5.1 Online/offline operation	117
9.5.2 Parameters for the basic configuration	118
9.5.3 Units	118
9.6 Field Communicator 375/475 (FC 375/475)	118
9.6.1 Installation	118
9.6.2 Operation	119
9.7 Asset Management Solutions (AMS)	120
9.7.1 Installation	120
9.7.2 Operation	120
9.8 Process Device Manager (PDM)	121
9.8.1 Installation	121
9.8.2 Operation	121
9.9 Field Device Manager (FDM)	122
9.9.1 Installation	122
9.9.2 Operation	122
9.10 Field Device Tool Device Type Manager (FDT DTM)	122
9.10.1 Installation	122
9.10.2 Operation	122

9.11 HART Menu Tree.....	123
9.11.1 HART Menu Tree - Field Communicator HART Application.....	123
9.11.2 HART Menu Tree AMS - Device's context menu	124
9.11.3 HART Menu Tree PDM - Menu Bar and Working Window	125
9.11.4 HART Menu Tree FDM - Device Configuration	126
9.11.5 Description of used abbreviations	126
9.11.6 Process Variables Root Menu.....	127
9.11.7 Diagnostic Root Menu	128
9.11.8 Device Root Menu.....	130
9.11.9 Offline Root Menu.....	133

1.1 Intended use



CAUTION!

Responsibility for the use of the measuring devices with regard to suitability, intended use and corrosion resistance of the used materials against the measured fluid lies solely with the operator.



INFORMATION!

The manufacturer is not liable for any damage resulting from improper use or use for other than the intended purpose.

The overall functionality of the **OPTISONIC 8300** flowmeter is the continuous measurement of actual volume flow, enthalpy flow, mass flow, flow speed, velocity of sound, gain, SNR and diagnosis value. The working area is defined in the next figure.

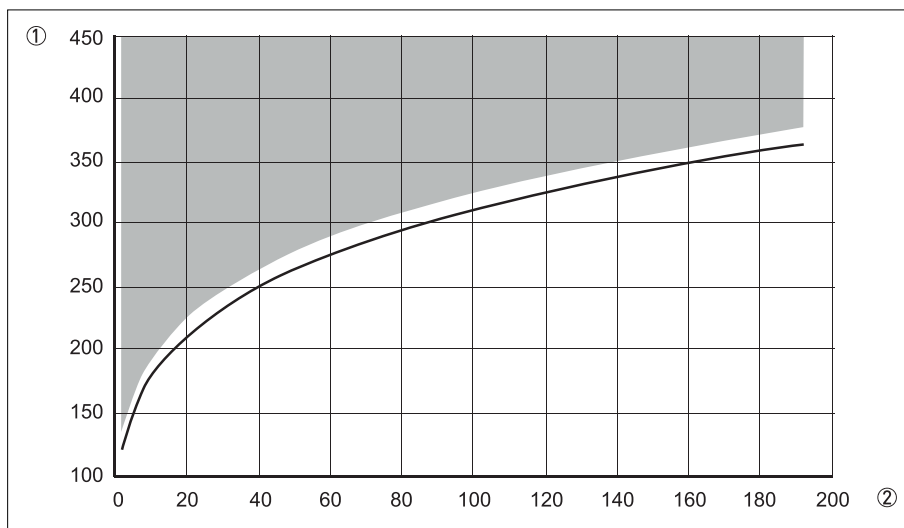

Figure 1-1: Steam saturation curve

- ① Temperature [°C]
- ② Pressure [Bara]

1.2 Certification

CE marking



The device fulfils the statutory requirements of the following EC directives:

- EMC Directive 2004/108/EC in conjunction with EN 61326-1: 2006
- Low Voltage Directive 2006/95/EC in conjunction with EN 61010-1: 2001
- NAMUR NE 21/04

The manufacturer certifies successful testing of the product by applying the CE marking.



DANGER!

For devices used in hazardous areas, additional safety notes apply; please refer to the Ex documentation.

1.3 Safety instructions from the manufacturer

1.3.1 Copyright and data protection

The contents of this document have been created with great care. Nevertheless, we provide no guarantee that the contents are correct, complete or up-to-date.

The contents and works in this document are subject to copyright. Contributions from third parties are identified as such. Reproduction, processing, dissemination and any type of use beyond what is permitted under copyright requires written authorisation from the respective author and/or the manufacturer.

The manufacturer tries always to observe the copyrights of others, and to draw on works created in-house or works in the public domain.

The collection of personal data (such as names, street addresses or e-mail addresses) in the manufacturer's documents is always on a voluntary basis whenever possible. Whenever feasible, it is always possible to make use of the offerings and services without providing any personal data.

We draw your attention to the fact that data transmission over the Internet (e.g. when communicating by e-mail) may involve gaps in security. It is not possible to protect such data completely against access by third parties.

We hereby expressly prohibit the use of the contact data published as part of our duty to publish an imprint for the purpose of sending us any advertising or informational materials that we have not expressly requested.

1.3.2 Disclaimer

The manufacturer will not be liable for any damage of any kind by using its product, including, but not limited to direct, indirect or incidental and consequential damages.

This disclaimer does not apply in case the manufacturer has acted on purpose or with gross negligence. In the event any applicable law does not allow such limitations on implied warranties or the exclusion of limitation of certain damages, you may, if such law applies to you, not be subject to some or all of the above disclaimer, exclusions or limitations.

Any product purchased from the manufacturer is warranted in accordance with the relevant product documentation and our Terms and Conditions of Sale.

The manufacturer reserves the right to alter the content of its documents, including this disclaimer in any way, at any time, for any reason, without prior notification, and will not be liable in any way for possible consequences of such changes.

1.3.3 Product liability and warranty

The operator shall bear responsibility for the suitability of the device for the specific purpose. The manufacturer accepts no liability for the consequences of misuse by the operator. Improper installation or operation of the devices (systems) will cause the warranty to be void. The respective "Standard Terms and Conditions" which form the basis for the sales contract shall also apply.

1.3.4 Information concerning the documentation

To prevent any injury to the user or damage to the device it is essential that you read the information in this document and observe applicable national standards, safety requirements and accident prevention regulations.

If this document is not in your native language and if you have any problems understanding the text, we advise you to contact your local office for assistance. The manufacturer can not accept responsibility for any damage or injury caused by misunderstanding of the information in this document.

This document is provided to help you establish operating conditions, which will permit safe and efficient use of this device. Special considerations and precautions are also described in the document, which appear in the form of icons as shown below.

1.3.5 Warnings and symbols used

Safety warnings are indicated by the following symbols.



DANGER!

This warning refers to the immediate danger when working with electricity.



DANGER!

This warning refers to the immediate danger of burns caused by heat or hot surfaces.



DANGER!

This warning refers to the immediate danger when using this device in a hazardous atmosphere.



DANGER!

These warnings must be observed without fail. Even partial disregard of this warning can lead to serious health problems and even death. There is also the risk of seriously damaging the device or parts of the operator's plant.



WARNING!

Disregarding this safety warning, even if only in part, poses the risk of serious health problems. There is also the risk of damaging the device or parts of the operator's plant.



CAUTION!

Disregarding these instructions can result in damage to the device or to parts of the operator's plant.



INFORMATION!

These instructions contain important information for the handling of the device.



LEGAL NOTICE!

This note contains information on statutory directives and standards.



• **HANDLING**

This symbol designates all instructions for actions to be carried out by the operator in the specified sequence.

➔ **RESULT**

This symbol refers to all important consequences of the previous actions.

1.4 Safety instructions for the operator



WARNING!

*In general, devices from the manufacturer may only be installed, commissioned, operated and maintained by properly trained and authorized personnel.
This document is provided to help you establish operating conditions, which will permit safe and efficient use of this device.*

2.1 Scope of delivery

**INFORMATION!**

Do a check of the packing list to make sure that you have all the elements given in the order.

**INFORMATION!**

Inspect the packaging carefully for damages or signs of rough handling. Report damage to the carrier and to the local office of the manufacturer.

**INFORMATION!**

The field device will arrive in two cartons. One carton contains the converter and one carton contains the sensor.

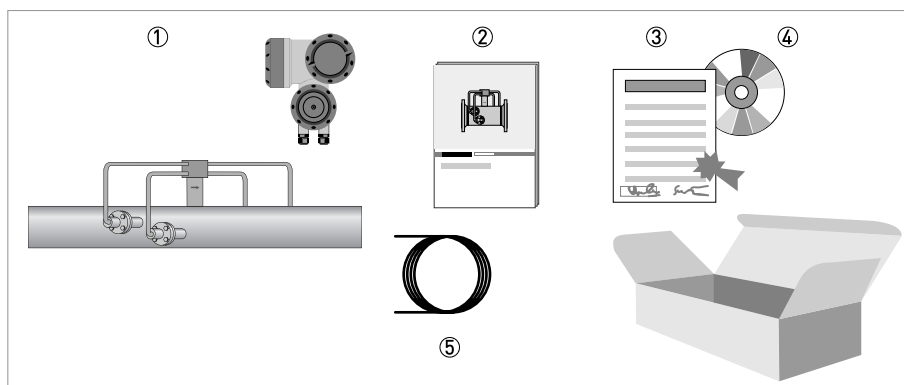

Figure 2-1: Scope of delivery

- ① Ordered flowmeter
- ② Product documentation
- ③ Factory calibration report
- ④ CD-ROM with product documentation in available languages
- ⑤ Signal cable (DN100 / 4": 1 cable; ≥DN150 / 6": 2 cables)

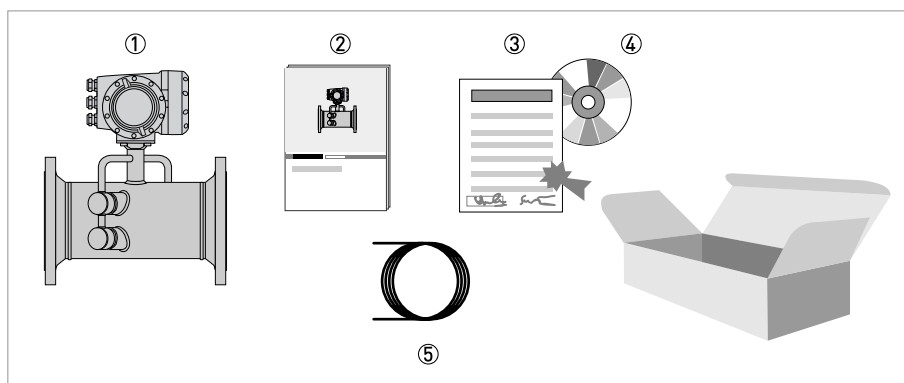

Figure 2-2: Scope of delivery

- ① Ordered flowmeter
- ② Product documentation
- ③ Factory calibration report
- ④ CD-ROM with product documentation in available languages
- ⑤ Signal cable (DN100 / 4": 1 cable; ≥DN150 / 6": 2 cables)

**INFORMATION!**

Assembly materials and tools are not part of the delivery. Use the assembly materials and tools in compliance with the applicable occupational health and safety directives.

2.2 Device description

The ultrasonic flowmeters are designed exclusively for the continuous measurement of actual volume flow, mass flow, molar mass, flow speed, velocity of sound, gain, SNR and diagnosis value.

Your measuring device is supplied ready for operation. The factory settings for the operating data have been made in accordance with your order specifications.

The following version is available:

- Remote version (electrical connection to the measuring sensor via signal cable)

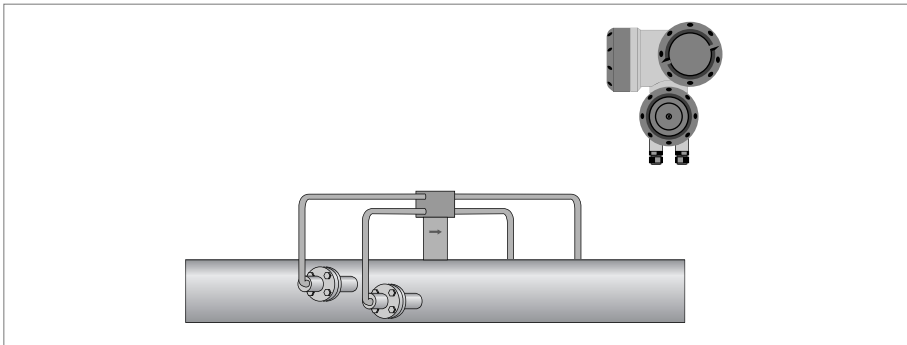

Figure 2-3: Device version

2.3 Field housing

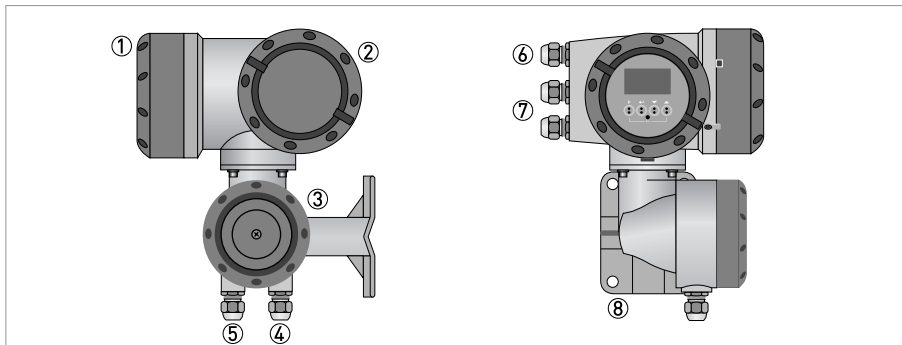

Figure 2-4: Construction of the field housing

- ① Cover for electronics and display
- ② Cover for power supply and inputs/outputs terminal compartment
- ③ Cover for for measuring sensor terminal compartment with locking screw
- ④ Cable entry for measuring sensor signal cable
- ⑤ Cable entry for measuring sensor signal cable
- ⑥ Cable entry for power supply
- ⑦ Cable entry for inputs and outputs
- ⑧ Mounting plate for pipe and wall mounting



INFORMATION!

Each time a housing cover is opened, the thread should be cleaned and greased.

Use only resin-free and acid-free grease.

Ensure that the housing gasket is properly fitted, clean and undamaged.

2.4 Nameplates



INFORMATION!

Look at the device nameplate to ensure that the device is delivered according to your order.
Check for the correct supply voltage printed on the nameplate.

2.4.1 Example of nameplate for the measuring sensor

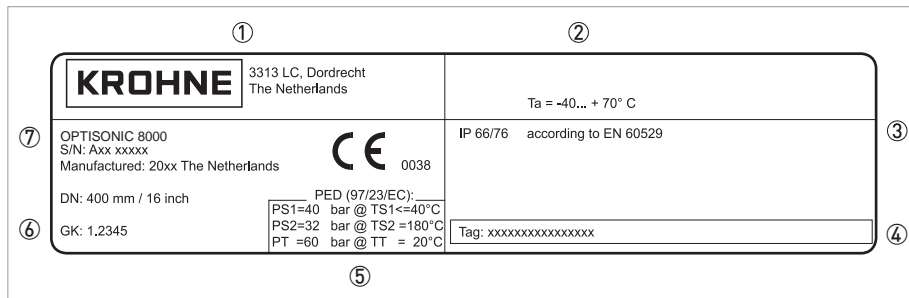

- ① Name and address of the manufacturer
- ② Ambient temperature
- ③ Protection class
- ④ Tag no.
- ⑤ PED data
- ⑥ Calibration data
- ⑦ Type designation of the flowmeter and CE sign with number(s) of notified body / bodies

2.4.2 Examples of nameplates on the signal converter (field version)

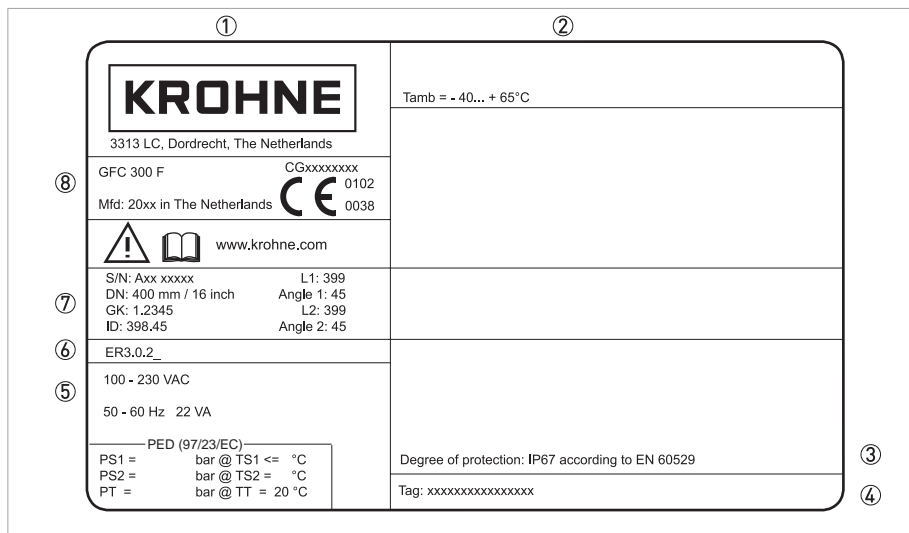

- ① Name and address of the manufacturer
- ② Ambient temperature
- ③ Protection class
- ④ Tag no.
- ⑤ Main supply data
- ⑥ Electronics revision number
- ⑦ Calibration data
- ⑧ Type designation of the flowmeter and CE sign with number(s) of notified body / bodies

Electrical connection data of inputs/outputs (example of basic version)



①	POWER	PE (FE)	CG 3x xxxxxx S/N: XXXxxxxx	KROHNE
		L(L+) N(L-)	  A = Active P = Passive NC = Not connected	
②	INPUT / OUTPUT	D -	P	PULSE OUT / STATUS OUT $I_{max} = 100 \text{ mA}@f \leq 10 \text{ Hz}$; $= 20 \text{ mA}@f \leq 12 \text{ kHz}$ $V_o = 1.5 \text{ V @ } 10 \text{ mA}$; $U_{max} = 32 \text{ VDC}$
		D		
③	INPUT / OUTPUT	C -	P	STATUS OUT $I_{max} = 100 \text{ mA}$; $V_{max} = 32 \text{ VDC}$
		C		
④	INPUT / OUTPUT	B -	P	STATUS OUT / CONTROL IN $I_{max} = 100 \text{ mA}$ $V_{on} > 19 \text{ VDC}$, $V_{off} < 2.5 \text{ VDC}$; $V_{max} = 32 \text{ VDC}$
		B		
⑤	INPUT / OUTPUT	A +	A	CURRENT OUT (HART)
		A -	P	Active (Terminals A & A+); $R_{Lmax} = 1 \text{ kohm}$
		A	P	Passive (Terminals A & A-); $V_{max} = 32 \text{ VDC}$

Figure 2-5: Example of a nameplate for electrical connection data of inputs and outputs

- ① Power supply (AC: L and N; DC: L+ and L-; PE for $\geq 24 \text{ VAC}$; FE for $\leq 24 \text{ VAC}$ and DC)
- ② Connection data of connection terminal D/D-
- ③ Connection data of connection terminal C/C-
- ④ Connection data of connection terminal B/B-
- ⑤ Connection data of connection terminal A/A-; A+ only operable in the basic version

- A = active mode; the signal converter supplies the power for connection of the subsequent devices
- P = passive mode; external power supply required for operation of the subsequent devices
- N/C = connection terminals not connected

3.1 General notes on installation

**INFORMATION!**

Inspect the packaging carefully for damages or signs of rough handling. Report damage to the carrier and to the local office of the manufacturer.

**INFORMATION!**

Do a check of the packing list to make sure that you have all the elements given in the order.

**INFORMATION!**

Look at the device nameplate to ensure that the device is delivered according to your order. Check for the correct supply voltage printed on the nameplate.

3.2 Storage

- Store the device in a dry, dust-free location.
- Avoid continuous direct sunlight.
- Store the device in its original packaging.
- Storage temperature: -50...+70°C / -58...+158°F

3.3 Transport

Measuring sensor

- Do not lift the measuring sensor by the connection box.
- Use hoisting belts only.
- To transport flange devices, use lifting straps. Wrap these around both process connections.

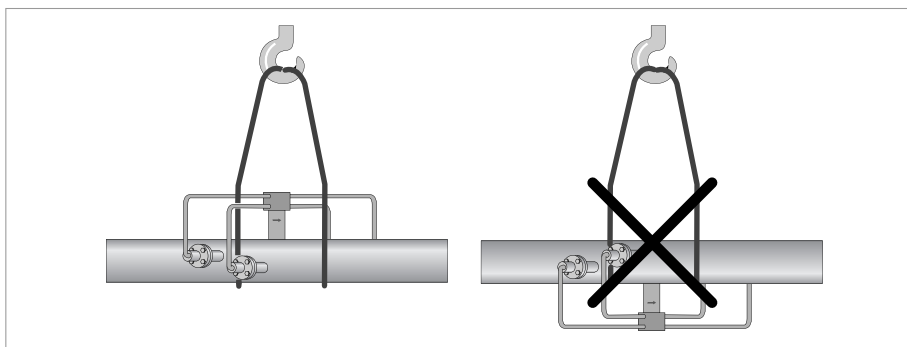

Figure 3-1: Transport

3.4 Installation requirements signal converter

- Allow 10...20 cm / 3.9...7.9" of space at the sides and rear of the signal converter to permit free air circulation.
- Protect signal converter against direct solar radiation, install a sunshield if necessary.
- Signal converters installed in switchgear cabinets require adequate cooling, e.g. by fan or heat exchanger.
- Do not expose the signal converter to intense vibration.

3.5 Vibration

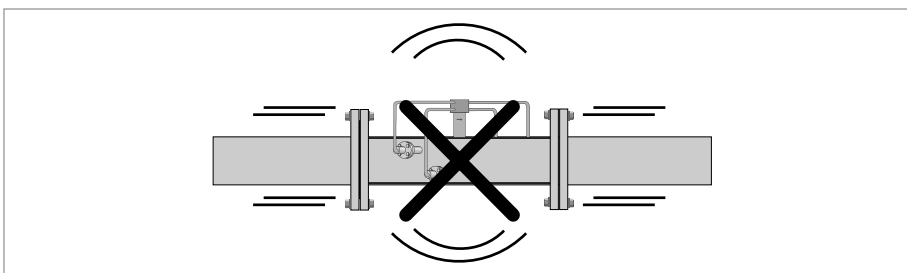

Figure 3-2: Avoid vibrations

3.6 General requirements sensor

To secure the optimum functioning of the flowmeter, please note the following observations.

- Install the flow sensor in a horizontal position in a slightly descending line.
- Do not install the flow sensor in a lowered pipe section to avoid that water can collect in the measuring tube.
- Orientate the flow sensor such that the path of the acoustic signal is in the horizontal plane.

For exchanging the transducers, please keep a free space of 0.3 m / 11.81" around the transducer.

3.6.1 Inlet and outlet

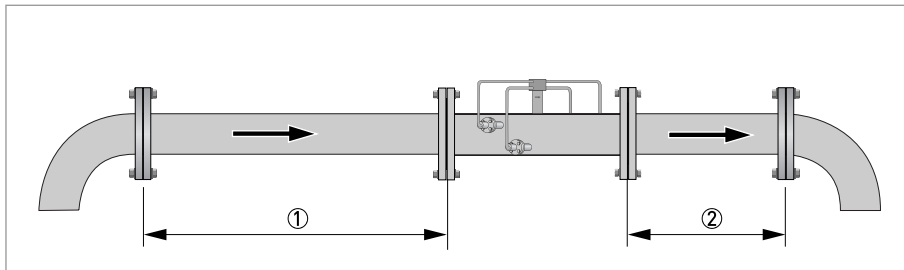

Figure 3-3: Recommended inlet and outlet

- ① ≥ 20 DN
- ② ≥ 3 DN

3.6.2 T-section

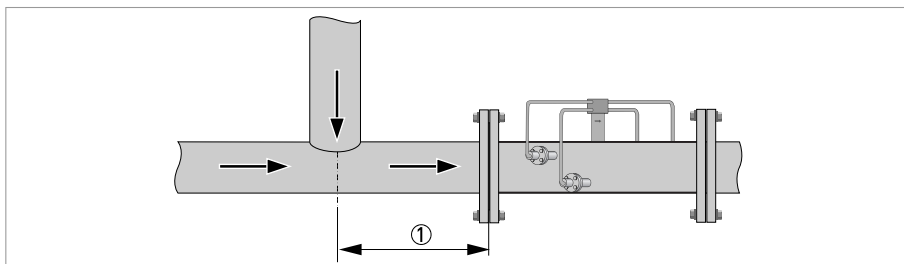

Figure 3-4: Distance behind a T-section

- ① ≥ 20 DN

3.6.3 Mounting position

- Horizontally with the acoustic path in horizontal plane

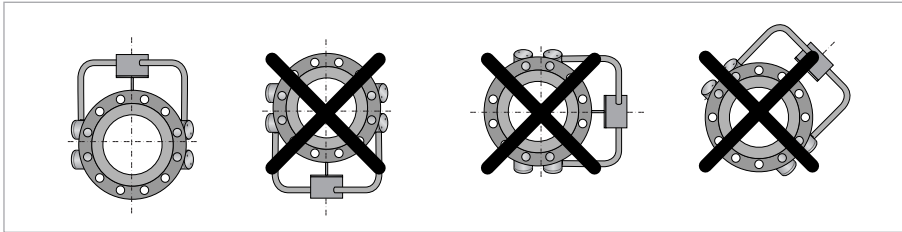

Figure 3-5: Mounting position

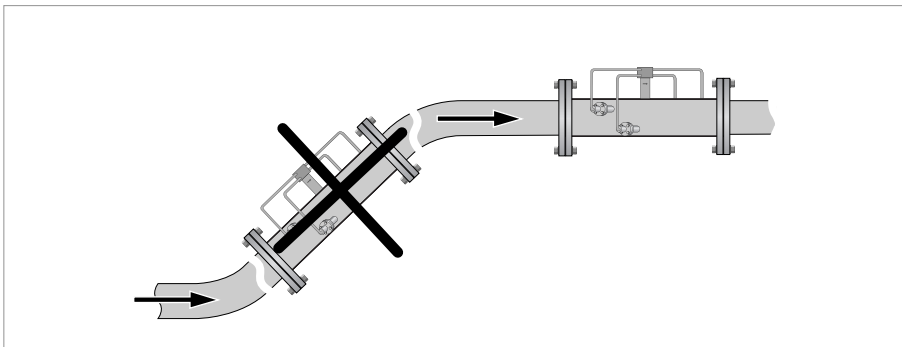

Figure 3-6: Horizontal mounting

3.6.4 Flange deviation



CAUTION!

Max. permissible deviation of pipe flange faces:

$$L_{max} - L_{min} \leq 0.5 \text{ mm} / 0.02''$$

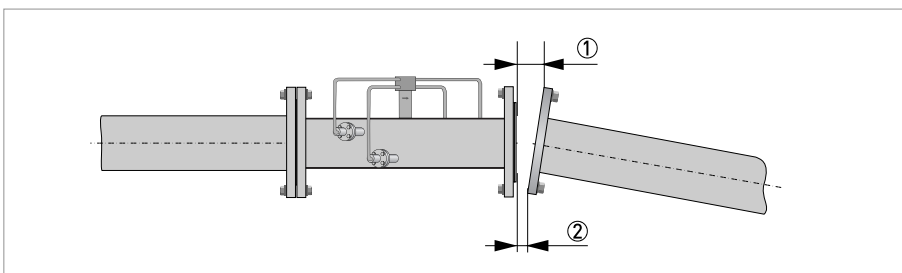

Figure 3-7: Flange deviation

- ① L_{max}
- ② L_{min}

3.6.5 Control valve

To avoid distorted flow profiles and interference caused by valve noise in the sensor, control valves or pressure reducers should not be installed in the same pipeline as the flowmeter. In case this is required, please contact the manufacturer.

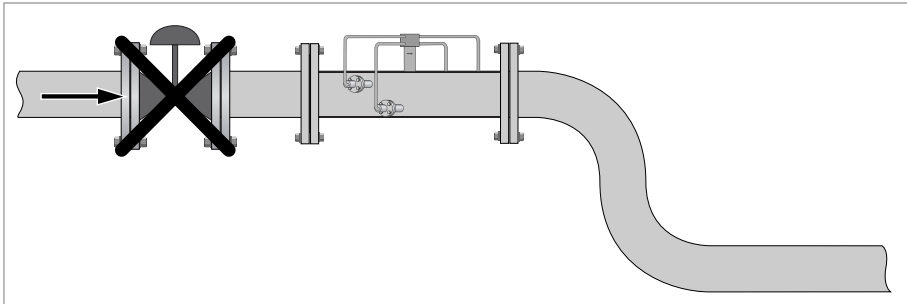

Figure 3-8: Control valve

3.6.6 Thermal insulation



CAUTION!

The flow sensor must be insulated to prevent humidity problems caused by condensation. Please make sure that the insulation is installed in accordance with the next image.



WARNING!

Keep the transducers and connection box free of insulation to allow cooling by free convection. The transducers can reach a temperature of up to 200°C!

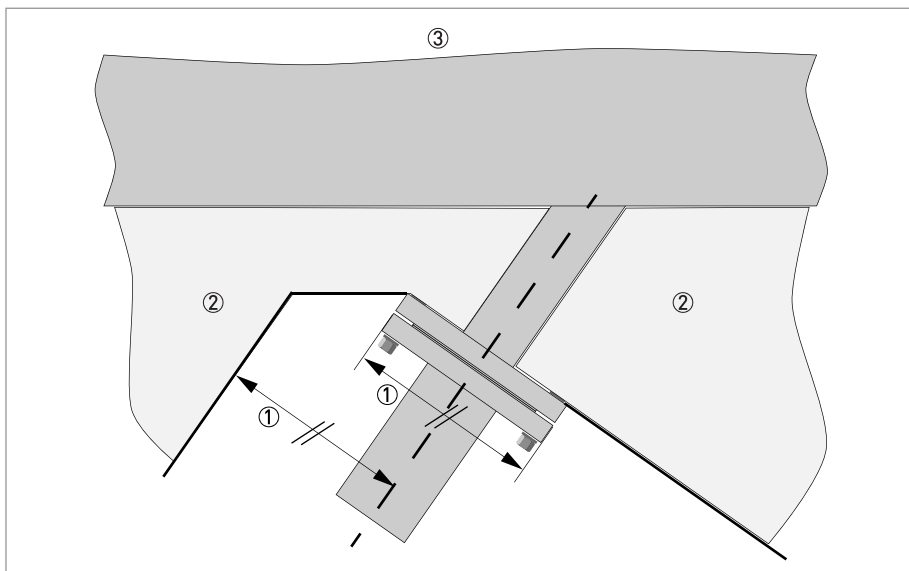

Figure 3-9: Thermal insulation

- ① Width of flange = free distance
- ② Insulation
- ③ Sensor tube

3.7 Mounting the field housing, remote version

**INFORMATION!**

Assembly materials and tools are not part of the delivery. Use the assembly materials and tools in compliance with the applicable occupational health and safety directives.

3.7.1 Pipe mounting

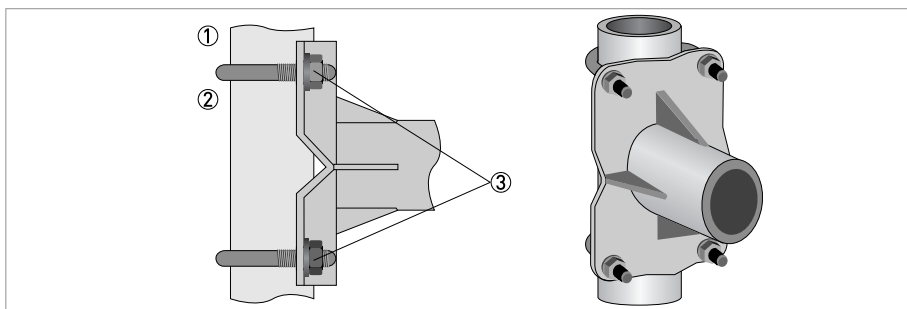

Figure 3-10: Pipe mounting of the field housing



- ① Fix the signal converter to the pipe.
- ② Fasten the signal converter using standard U-bolts and washers.
- ③ Tighten the nuts.

3.7.2 Wall mounting

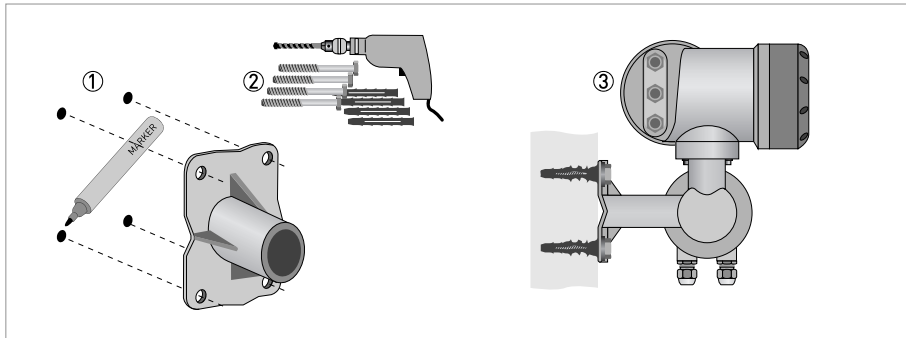
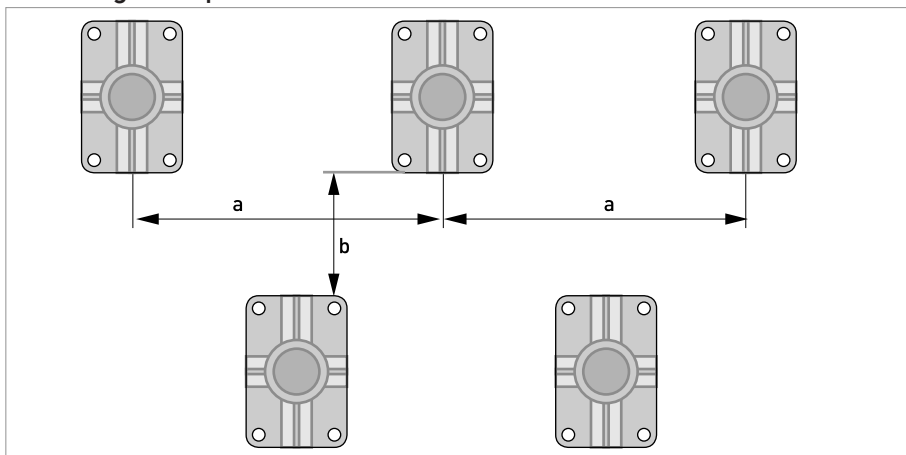

Figure 3-11: Wall mounting of the field housing



- ① Prepare the holes with the aid of the mounting plate.
For further information refer to *Mounting plate, field housing* on page 110.
- ② Use the mounting material and tools in compliance with the applicable occupational health and safety directives.
- ③ Fasten the housing securely to the wall.

Mounting multiple devices next to each other



$a \geq 600 \text{ mm} / 23.6''$
 $b \geq 250 \text{ mm} / 9.8''$

3.7.3 Turning the display of the field housing version

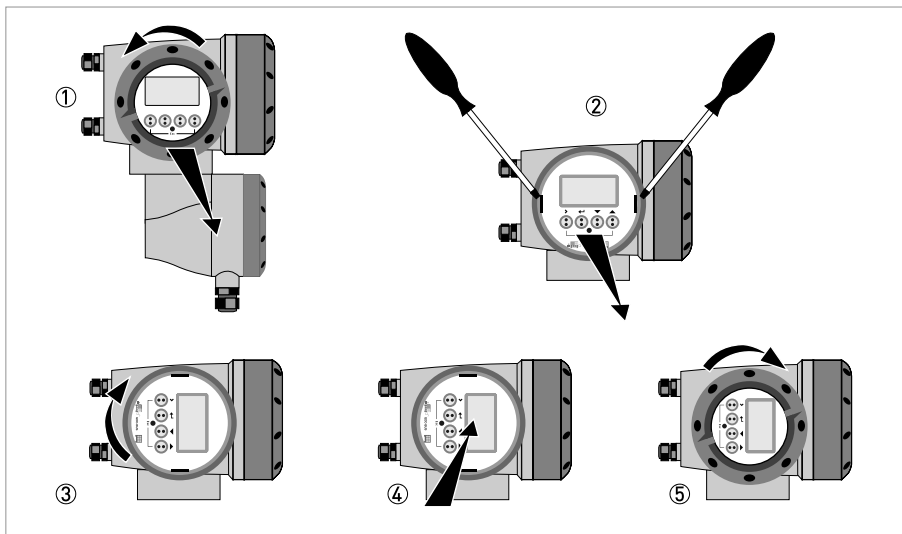

Figure 3-12: Turning the display of the field housing version



The display of the field housing version can be turned in 90° increments.

- ① Unscrew the cover from the display and operation control unit.
- ② Using a suitable tool, pull out the two metal puller devices to the left and right of the display.
- ③ Pull out the display between the two metal puller devices and rotate it to the required position.
- ④ Slide the display and then the metal puller devices back into the housing.
- ⑤ Re-fit the cover and tighten it by hand.

**CAUTION!**

The ribbon cable of the display must not be folded or twisted repeatedly.

**INFORMATION!**

Each time a housing cover is opened, the thread should be cleaned and greased. Use only resin-free and acid-free grease.

Ensure that the housing gasket is properly fitted, clean and undamaged.

4.1 Safety instructions

**DANGER!**

All work on the electrical connections may only be carried out with the power disconnected. Take note of the voltage data on the nameplate!

**DANGER!**

Observe the national regulations for electrical installations!

**DANGER!**

For devices used in hazardous areas, additional safety notes apply; please refer to the Ex documentation.

**WARNING!**

Observe without fail the local occupational health and safety regulations. Any work done on the electrical components of the measuring device may only be carried out by properly trained specialists.

**INFORMATION!**

Look at the device nameplate to ensure that the device is delivered according to your order. Check for the correct supply voltage printed on the nameplate.

4.2 Signal cable OPTISONIC 8000 Sensor

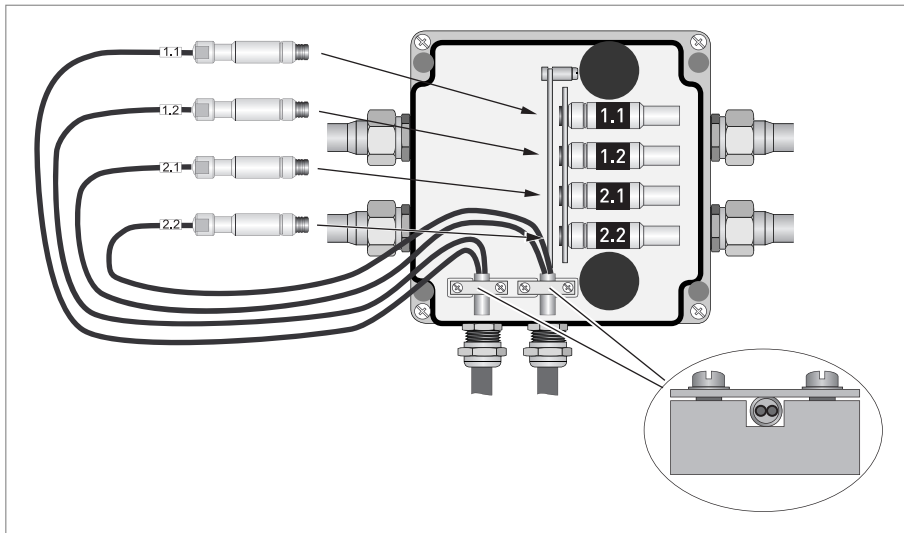
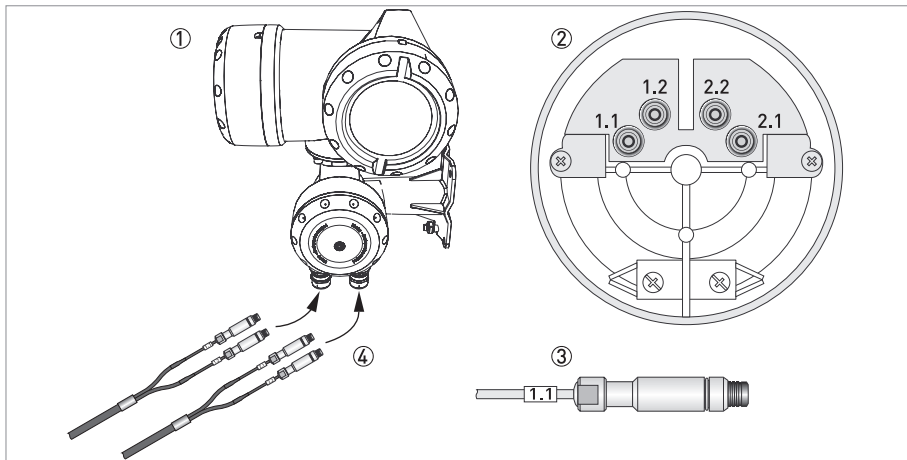

Figure 4-1: Connection of cables in connection box on sensor

4.3 Signal cable converter



- ① Converter housing.
- ② Open connection box.
- ③ Marking on cable.
- ④ Insert cables through cable glands.

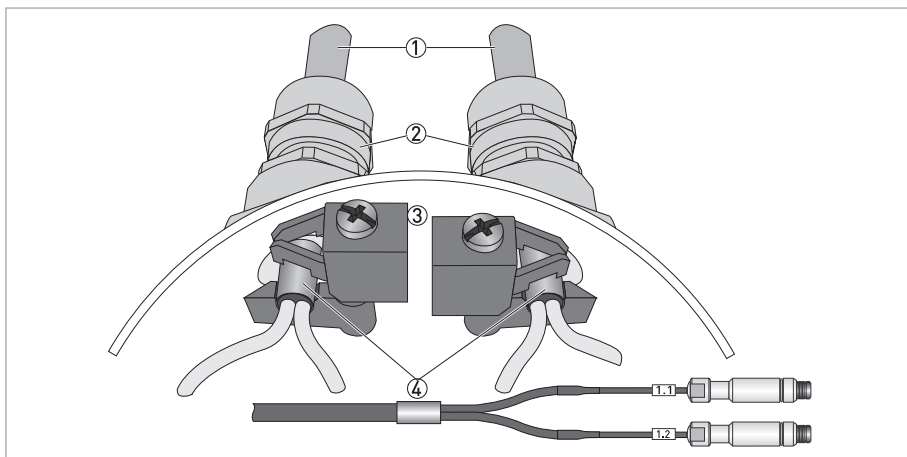

Figure 4-2: Clamp the cables on the shielding bush.

- ① Cables.
- ② Cable glands.
- ③ Grounding clamps.
- ④ Cable with metal shielding bush.

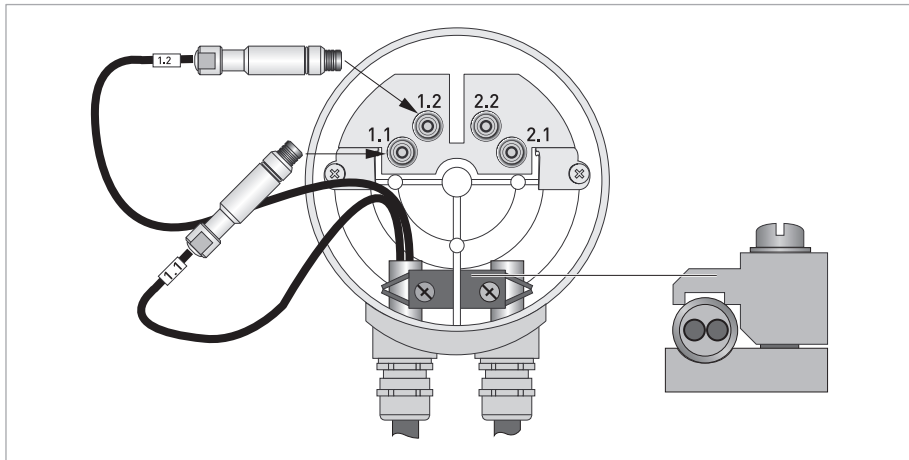

Figure 4-3: Connect the cables on the signal converter.

4.4 Power supply



WARNING!

When this device is intended for permanent connection to the mains.

It is required (for example for service) to mount an external switch or circuit breaker near the device for disconnection from the mains. It shall be easily reachable by the operator and marked as the disconnecting the device for this equipment.

The switch or circuit breaker and wiring has to be suitable for the application and shall also be in accordance with the local (safety) requirements of the (building) installation (e.g. IEC 60947-1 / -3)



INFORMATION!

The power terminals in the terminal compartments are equipped with additional hinged lids to prevent accidental contact.

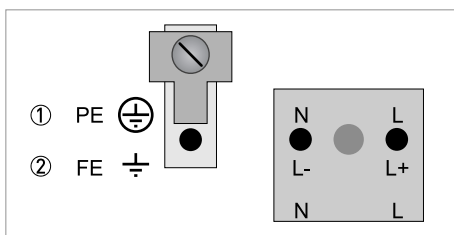

① 100...230 VAC (-15% / +10%), 22 VA

② 24 VAC/DC (AC: -15% / +10%; DC: -25% / +30%), 22 VA or 12 W



DANGER!

The device must be grounded in accordance with regulations in order to protect personnel against electric shocks.

100...230 VAC

- Connect the protective ground conductor PE of the mains power supply to the separate terminal in the terminal compartment of the signal converter.
- Connect the live conductor to the L terminal and the neutral conductor to the N terminal.

24 VAC/DC

- Connect a functional ground FE to the separate U-clamp terminal in the terminal compartment of the signal converter.
- When connecting to functional extra-low voltages, provide a facility for protective separation (PELV) (VDE 0100 / VDE 0106 and/or IEC 364 / IEC 536 or relevant national regulations).

4.5 Inputs and outputs, overview**4.5.1 Combinations of the inputs/outputs (I/Os)**

This signal converter is available with various input/output combinations.

Ex i version

- Current outputs can be active or passive.

Modular version

- Depending on the task, the device can be configured with various output modules.

Bus systems

- For hazardous areas, all of the input/output variants for the housing designs with terminal compartment in the Ex d (pressure-resistant casing) or Ex e (increased safety) versions can be delivered.
- Please refer to the separate instructions for connection and operation of the Ex-devices.

4.5.2 Description of the CG number

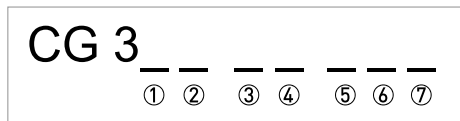

Figure 4-4: Marking (CG number) of the electronics module and input/output variants

- ① ID number: 6
- ② ID number: 0 = standard
- ③ Power supply option
- ④ Display (language versions)
- ⑤ Input/output version (I/O)
- ⑥ 1st optional module for connection terminal A
- ⑦ 2nd optional module for connection terminal B

The last 3 digits of the CG number (⑤, ⑥ and ⑦) indicate the assignment of the terminal connections. Please see the following examples.

Examples for CG number

CG 360 11 100	100...230 VAC & standard display; basic I/O: I_a or I_p & S_p/C_p & S_p & P_p/S_p
CG 360 11 7FK	100...230 VAC & standard display; modular I/O: I_a & P_N/S_N and optional module P_N/S_N & C_N
CG 360 81 4EB	24 VDC & standard display; modular I/O: I_a & P_a/S_a and optional module P_p/S_p & I_p

Description of abbreviations and CG identifier for possible optional modules on terminals A and B

Abbreviation	Identifier for CG No.	Description
I_a	A	Active current output
I_p	B	Passive current output
P_a / S_a	C	Active pulse output, frequency output, status output or limit switch (changeable)
P_p / S_p	E	Passive pulse output, frequency output, status output or limit switch (changeable)
P_N / S_N	F	Passive pulse output, frequency output, status output or limit switch acc. to NAMUR (changeable)
C_a	G	Active control input
C_p	K	Passive control input
C_N	H	Active control input to NAMUR Signal converter monitors cable breaks and short circuits acc. to EN 60947-5-6. Errors indicated on LC display. Error messages possible via status output.
IIn_a	P	Active current input
IIn_p	R	Passive current input
-	8	No additional module installed
-	0	No further module possible

4.5.3 Alterable input/output versions

This signal converter is available with various input/output combinations.

- The grey boxes in the tables denote unassigned or unused connection terminals.
- In the table, only the final digits of the CG no. are depicted.
- Term. = (connection) terminal

CG no.	Connection terminals									
	A+	A	A-	B	B-	C	C-	D	D-	

Modular IOs (option)

4 __		max. 2 optional modules for term. A + B	I _a + HART® active	P _a / S _a active ①
8 __		max. 2 optional modules for term. A + B	I _p + HART® passive	P _a / S _a active ①
6 __		max. 2 optional modules for term. A + B	I _a + HART® active	P _p / S _p passive ①
B __		max. 2 optional modules for term. A + B	I _p + HART® passive	P _p / S _p passive ①
7 __		max. 2 optional modules for term. A + B	I _a + HART® active	P _N / S _N NAMUR ①
C __		max. 2 optional modules for term. A + B	I _p + HART® passive	P _N / S _N NAMUR ①

Modbus (Option)

G __ ②		max. 2 optional modules for term. A + B		Common	Sign. B (D1)	Sign. A (D0)
H __ ③		max. 2 optional modules for term. A + B		Common	Sign. B (D1)	Sign. A (D0)

① Changeable

② Not activated bus terminator

③ Activated bus terminator

4.6 Description of the inputs and outputs

4.6.1 Current output

**INFORMATION!**

The current outputs must be connected depending on the version! Which I/O versions and inputs/outputs are installed in your signal converter are indicated on the sticker in the cover of the terminal compartment.

- All outputs are electrically isolated from each other and from all other circuits.
- All operating data and functions can be adjusted.
- Passive mode:
External power $U_{\text{ext}} \leq 32 \text{ VDC}$ at $I \leq 22 \text{ mA}$
- Active mode:
Load impedance $R_L \leq 1 \text{ k}\Omega$ at $I \leq 22 \text{ mA}$;
 $R_L \leq 450 \Omega$ at $I \leq 22 \text{ mA}$ for Ex i outputs
- Self-monitoring: interruption or load impedance too high in the current output loop
- Error message possible via status output, error indication on LC display.
- Current value error detection can be adjusted.
- Automatic range conversion via threshold or control input. The setting range for the threshold is between 5 and 80% of $Q_{100\%}$, $\pm 0...5\%$ hysteresis (corresponding ratio from smaller to larger range of 1:20 to 1:1.25).
Signaling of the active range possible via a status output (adjustable).
- Forward/reverse flow measurement (F/R mode) is possible.

**INFORMATION!**

For further information refer to Connection diagrams of inputs and outputs on page 37.

**DANGER!**

For devices used in hazardous areas, additional safety notes apply; please refer to the Ex documentation.

4.6.2 Pulse and frequency output



INFORMATION!

Depending on the version, the pulse and frequency outputs must be connected passively or actively or according to NAMUR EN 60947-5-6! Which I/O version and inputs/outputs are installed in your signal converter are indicated on the sticker in the cover of the terminal compartment.

- All outputs are electrically isolated from each other and from all other circuits.
- All operating data and functions can be adjusted.
- Passive mode:
External power supply required: $U_{\text{ext}} \leq 32 \text{ VDC}$
 $I \leq 20 \text{ mA}$ at $f \leq 10 \text{ kHz}$ (override up to $f_{\text{max}} \leq 12 \text{ kHz}$)
 $I \leq 100 \text{ mA}$ at $f \leq 100 \text{ Hz}$
- Active mode:
Use of the internal power supply: $U_{\text{nom}} = 24 \text{ VDC}$
 $I \leq 20 \text{ mA}$ at $f \leq 10 \text{ kHz}$ (over range up to $f_{\text{max}} \leq 12 \text{ kHz}$)
 $I \leq 20 \text{ mA}$ at $f \leq 100 \text{ Hz}$
- NAMUR mode: passive in accordance with EN 60947-5-6, $f \leq 10 \text{ kHz}$,
over range up to $f_{\text{max}} \leq 12 \text{ kHz}$
- Scaling:
Frequency output: in pulses per time unit (e.g. 1000 pulses/s at $Q_{100\%}$);
Pulse output: quantity per pulse.
- Pulse width:
symmetric (pulse duty factor 1:1, independent of output frequency)
automatic (with fixed pulse width, duty factor approx. 1:1 at $Q_{100\%}$) or
fixed (pulse width adjustable as required from 0.05 ms...2 s)
- Forward / reverse flow measurement (F/R mode) is possible.
- All pulse and frequency outputs can also be used as a status output / limit switch.



INFORMATION!

For further information refer to Connection diagrams of inputs and outputs on page 37.



DANGER!

For devices used in hazardous areas, additional safety notes apply; please refer to the Ex documentation.

4.6.3 Status output and limit switch

**INFORMATION!**

Depending on the version, the status outputs and limit switches must be connected passively or actively or according to NAMUR EN 60947-5-6! Which I/O version and inputs/outputs are installed in your signal converter are indicated on the sticker in the cover of the terminal compartment.

- The status outputs / limit switches are electrically isolated from each other and from all other circuits.
- The output stages of the status outputs/limit switches during simple active or passive operation behave like relay contacts and can be connected with any polarity.
- All operating data and functions can be adjusted.
- Passive mode:
External power supply required: $U_{\text{ext}} \leq 32 \text{ VDC}$; $I \leq 100 \text{ mA}$

For the Ex i I/O signal converter:

NAMUR characteristic 4.7 mA / 0.77 mA

- Active mode:
Use of the internal power supply: $U_{\text{nom}} = 24 \text{ VDC}$; $I \leq 20 \text{ mA}$
- NAMUR mode:
Passive in accordance with EN 60947-5-6
- For information on the adjustable operating states refer to *Function tables* on page 65.

**INFORMATION!**

For further information refer to *Connection diagrams of inputs and outputs* on page 37.

**DANGER!**

For devices used in hazardous areas, additional safety notes apply; please refer to the *Ex documentation*.

4.6.4 Control input

**INFORMATION!**

Depending on the version, the control inputs must be connected passively or actively or according to NAMUR EN 60947-5-6! Which I/O version and inputs/outputs are installed in your signal converter are indicated on the sticker in the cover of the terminal compartment.

- All control inputs are electrically isolated from each other and from all other circuits.
- All operating data and functions can be adjusted.
- Passive mode: external power supply required:
 $U_{\text{ext}} \leq 32 \text{ VDC}$
- Active mode: use of the internal power supply:
 $U_{\text{nom}} = 24 \text{ VDC}$
- NAMUR mode: in accordance with EN 60947-5-6
(Active control input to NAMUR EN 60947-5-6: signal converter monitors cable breaks and short circuits acc. to EN 60947-5-6. Errors indicated on LC display. Error messages possible via status output.
- For information on the adjustable operating states refer to *Function tables* on page 65.

**INFORMATION!**

For further information refer to *Connection diagrams of inputs and outputs* on page 37.

**DANGER!**

For devices used in hazardous areas, additional safety notes apply; please refer to the *Ex documentation*.

4.7 Electrical connection of the inputs and outputs



INFORMATION!

Assembly materials and tools are not part of the delivery. Use the assembly materials and tools in compliance with the applicable occupational health and safety directives.

4.7.1 Field housing, electrical connection of the inputs and outputs



DANGER!

All work on the electrical connections may only be carried out with the power disconnected. Take note of the voltage data on the nameplate!

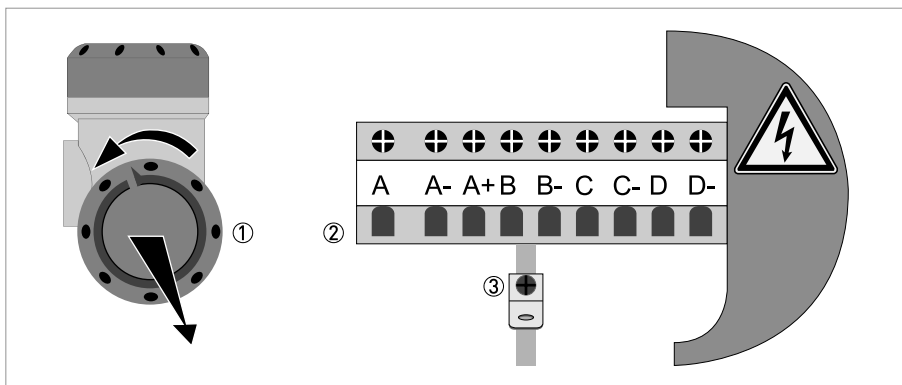

Figure 4-5: Terminal compartment for inputs and outputs



- ① Open the housing cover
- ② Push the prepared cable through the cable entry and connect the necessary conductors.
- ③ Connect the shield if necessary.



- Close the cover of the terminal compartment.
- Close the housing cover.



INFORMATION!

Each time a housing cover is opened, the thread should be cleaned and greased. Use only resin-free and acid-free grease.

Ensure that the housing gasket is properly fitted, clean and undamaged.

4.7.2 Laying electrical cables correctly

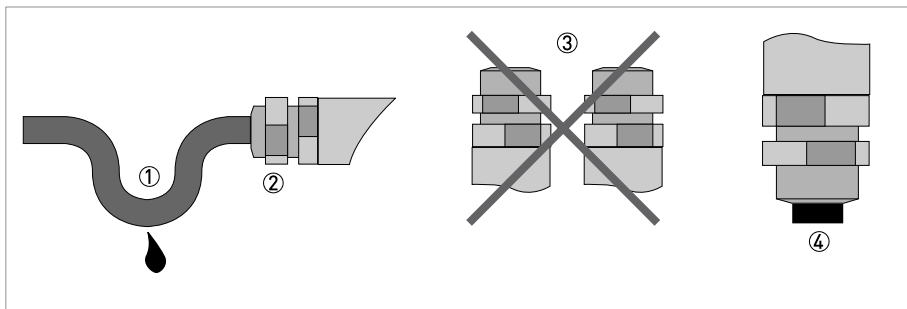

Figure 4-6: Protect housing from dust and water



- ① Lay the cable in a loop just before the housing.
- ② Tighten the screw connection of the cable entry securely.
- ③ Never mount the housing with the cable entries facing upwards.
- ④ Seal cable entries that are not needed with a plug.

4.8 Connection diagrams of inputs and outputs

4.8.1 Important notes



INFORMATION!

Depending on the version, the inputs/outputs must be connected passively or actively or acc. to NAMUR EN 60947-5-6! Which I/O version and inputs/outputs are installed in your signal converter are indicated on the sticker in the cover of the terminal compartment.

- All groups are electrically isolated from each other and from all other input and output circuits.
- Passive mode: An external power supply is necessary to operate (activation) the subsequent devices (U_{ext}).
- Active mode: The signal converter supplies the power for operation (activation) of the subsequent devices, observe max. operating data.
- Terminals that are not used should not have any conductive connection to other electrically conductive parts.



DANGER!

For devices used in hazardous areas, additional safety notes apply; please refer to the Ex documentation.

Description of the used abbreviations

I_a	I_p	Current output active or passive
P_a	P_p	Pulse/frequency output active or passive
P_N		Pulse/frequency output passive acc. to NAMUR EN 60947-5-6
S_a	S_p	Status output/limit switch active or passive
S_N		Status output/limit switch passive acc. to NAMUR EN 60947-5-6
C_a	C_p	Control input active or passive
C_N		Control input active acc. to NAMUR EN 60947-5-6: Signal converter monitors cable breaks and short circuits acc. to EN 60947-5-6. Errors indicated on LC display. Error messages possible via status output.
IIn_a	IIn_p	Current input active or passive

4.8.2 Description of the electrical symbols



	mA meter 0...20 mA or 4...20 mA and other R_L is the internal resistance of the measuring point including the cable resistance
	DC voltage source (U_{ext}), external power supply, any connection polarity
	DC voltage source (U_{ext}), observe connection polarity according to connection diagrams
	Internal DC voltage source
	Controlled internal power source in the device
	Electronic or electromagnetic counter At frequencies above 100 Hz, shielded cables must be used to connect the counters. R_i Internal resistance of the counter
	Button, NO contact or similar

Table 4-1: Description of symbols

4.8.3 Basic inputs/outputs

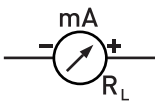
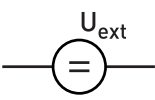
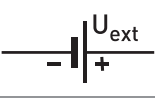
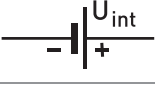
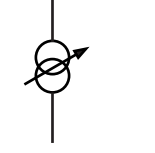
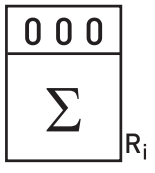

CAUTION!
Observe connection polarity.

Current output active (HART[®]), basic I/Os

- $U_{\text{int, nom}} = 24 \text{ VDC}$ nominal
- $I \leq 22 \text{ mA}$
- $R_L \leq 1 \text{ k}\Omega$

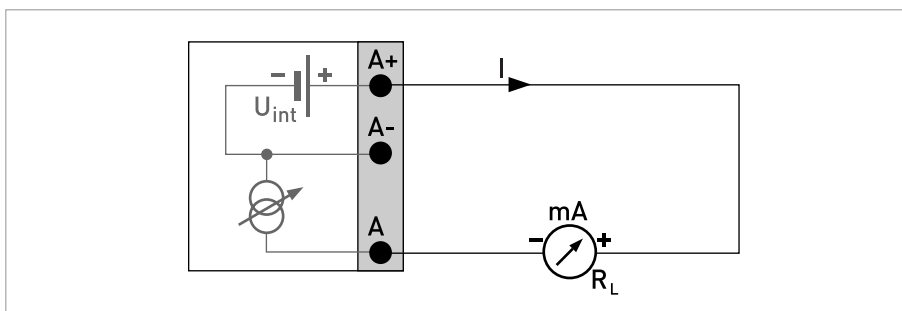

Figure 4-7: Current output active I_a

Current output passive (HART[®]), basic I/Os

- $U_{\text{int, nom}} = 24 \text{ VDC}$ nominal
- $U_{\text{ext}} \leq 32 \text{ VDC}$
- $I \leq 22 \text{ mA}$
- $U_0 \geq 1.8 \text{ V}$
- $R_L \leq (U_{\text{ext}} - U_0) / I_{\text{max}}$

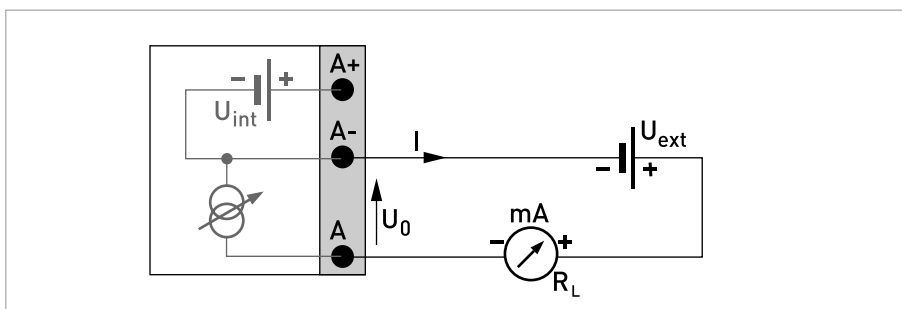

Figure 4-8: Current output passive I_p

**INFORMATION!**

- **Compact and field housing version:** Shield connected via the cable terminals in the terminal compartment.
- **Wall-mounted version:** Shield connected using 6.3 mm / 0.25" push-on connectors (insulation to DIN 46245) in the terminal compartment.
- Any connection polarity.

Pulse/frequency output passive, basic I/Os

- $U_{\text{ext}} \leq 32 \text{ VDC}$
- f_{max} in operating menu set to $f_{\text{max}} \leq 100 \text{ Hz}$:
 $I \leq 100 \text{ mA}$
 open:
 $I \leq 0.05 \text{ mA}$ at $U_{\text{ext}} = 32 \text{ VDC}$
 closed:
 $U_{0, \text{max}} = 0.2 \text{ V}$ at $I \leq 10 \text{ mA}$
 $U_{0, \text{max}} = 2 \text{ V}$ at $I \leq 100 \text{ mA}$
- f_{max} in the operating menu set to $100 \text{ Hz} < f_{\text{max}} \leq 10 \text{ kHz}$:
 $I \leq 20 \text{ mA}$
 open:
 $I \leq 0.05 \text{ mA}$ at $U_{\text{ext}} = 32 \text{ VDC}$
 closed:
 $U_{0, \text{max}} = 1.5 \text{ V}$ at $I \leq 1 \text{ mA}$
 $U_{0, \text{max}} = 2.5 \text{ V}$ at $I \leq 10 \text{ mA}$
 $U_{0, \text{max}} = 5.0 \text{ V}$ at $I \leq 20 \text{ mA}$
- If the following maximum load resistance $R_{L, \text{max}}$ is exceeded, the load resistance R_L must be reduced accordingly by parallel connection of R :
 $f \leq 100 \text{ Hz}$: $R_{L, \text{max}} = 47 \text{ k}\Omega$
 $f \leq 1 \text{ kHz}$: $R_{L, \text{max}} = 10 \text{ k}\Omega$
 $f \leq 10 \text{ kHz}$: $R_{L, \text{max}} = 1 \text{ k}\Omega$
- The minimum load resistance $R_{L, \text{min}}$ is calculated as follows:
 $R_{L, \text{min}} = (U_{\text{ext}} - U_0) / I_{\text{max}}$
- Can also be set as status output; for the electrical connection refer to status output connection diagram.

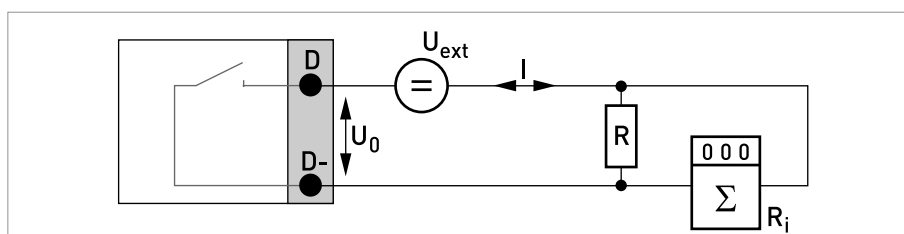
Figure 4-9: Pulse/frequency output passive P_p

**INFORMATION!**

- Any connection polarity.

Status output / limit switch passive, basic I/Os

- $U_{\text{ext}} \leq 32 \text{ VDC}$
- $I \leq 100 \text{ mA}$
- $R_{L, \text{max}} = 47 \text{ k}\Omega$
 $R_{L, \text{min}} = (U_{\text{ext}} - U_0) / I_{\text{max}}$
- open:
 $I \leq 0.05 \text{ mA}$ at $U_{\text{ext}} = 32 \text{ VDC}$
 closed:
 $U_{0, \text{max}} = 0.2 \text{ V}$ at $I \leq 10 \text{ mA}$
 $U_{0, \text{max}} = 2 \text{ V}$ at $I \leq 100 \text{ mA}$
- The output is open when the device is de-energized.
- X stands for the terminals B, C or D. The functions of the connection terminals depend on the settings refer to *Function tables* on page 65.

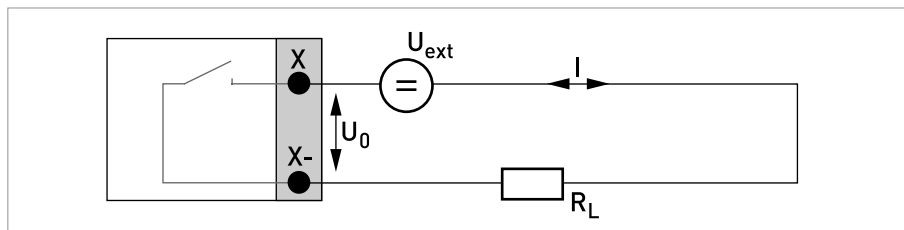
Figure 4-10: Status output / limit switch passive S_p **Control input passive, basic I/Os**

- $8 \text{ V} \leq U_{\text{ext}} \leq 32 \text{ VDC}$
- $I_{\text{max}} = 6.5 \text{ mA}$ at $U_{\text{ext}} \leq 24 \text{ VDC}$
 $I_{\text{max}} = 8.2 \text{ mA}$ at $U_{\text{ext}} \leq 32 \text{ VDC}$
- Switching point for identifying "contact open or closed":
 Contact open (off): $U_0 \leq 2.5 \text{ V}$ with $I_{\text{nom}} = 0.4 \text{ mA}$
 Contact closed (on): $U_0 \geq 8 \text{ V}$ with $I_{\text{nom}} = 2.8 \text{ mA}$
- Can also be set as a status output; for the electrical connection refer to status output connection diagram.

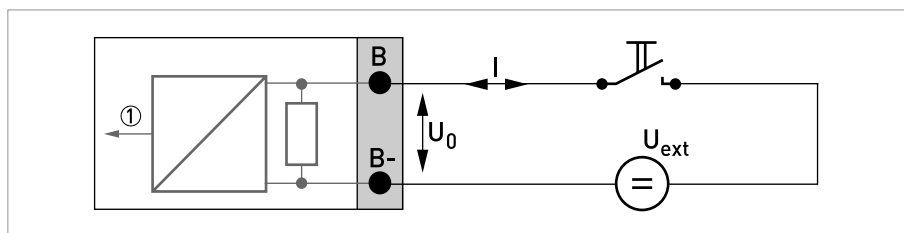
Figure 4-11: Control input passive C_p

① Signal

4.8.4 Modular inputs/outputs and bus systems



CAUTION!
Observe connection polarity.

**INFORMATION!**

- For further information on electrical connection refer to *Description of the inputs and outputs* on page 31.
- For the electrical connection of bus systems, please refer to the separate documentation for the respective bus systems.

Current output active (only current output terminals C/C- have HART[®] capability), modular I/Os

- $U_{\text{int, nom}} = 24 \text{ VDC}$
- $I \leq 22 \text{ mA}$
- $R_L \leq 1 \text{ k}\Omega$
- X designates the connection terminals A, B or C, depending on the version of the signal converter.

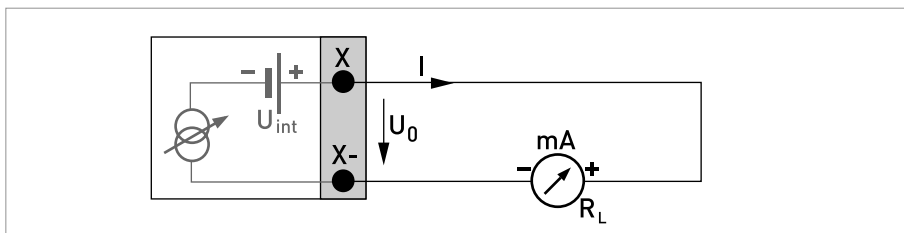

Figure 4-12: Current output active I_a

Current output passive (only current output terminals C/C- have HART[®] capability), modular I/Os

- $U_{\text{ext}} \leq 32 \text{ VDC}$
- $I \leq 22 \text{ mA}$
- $U_0 \geq 1.8 \text{ V}$
- $R_{L, \text{max}} = (U_{\text{ext}} - U_0) / I_{\text{max}}$
- X designates the connection terminals A, B or C, depending on the version of the signal converter.

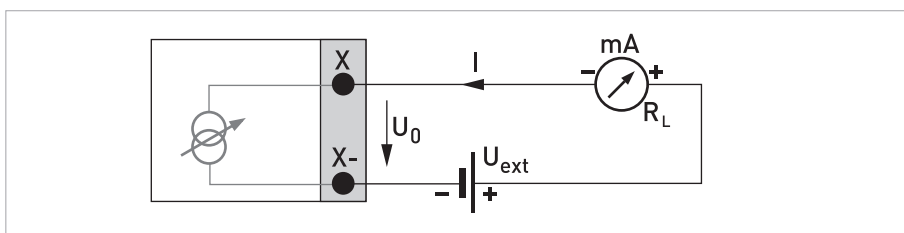

Figure 4-13: Current output passive I_p

**INFORMATION!**

- For frequencies above 100 Hz, shielded cables are to be used in order to reduce effects from electrical interferences (EMC).
- **Compact and field housing versions:** Shield connected via the cable terminals in the terminal compartment.
Wall-mounted version: Shield connected using 6.3 mm / 0.25" push-on connectors (insulation to DIN 46245) in the terminal compartment.
- Any connection polarity.

Pulse/frequency output active, modular I/Os

- $U_{nom} = 24 \text{ VDC}$
- f_{max} in the operating menu set to $f_{max} \leq 100 \text{ Hz}$:
 $I \leq 20 \text{ mA}$
 open:
 $I \leq 0.05 \text{ mA}$
 closed:
 $U_{0, nom} = 24 \text{ V}$ at $I = 20 \text{ mA}$
- f_{max} in operating menu set to $100 \text{ Hz} < f_{max} \leq 10 \text{ kHz}$:
 $I \leq 20 \text{ mA}$
 open:
 $I \leq 0.05 \text{ mA}$
 closed:
 $U_{0, nom} = 22.5 \text{ V}$ at $I = 1 \text{ mA}$
 $U_{0, nom} = 21.5 \text{ V}$ at $I = 10 \text{ mA}$
 $U_{0, nom} = 19 \text{ V}$ at $I = 20 \text{ mA}$
- If the following maximum load impedance $R_{L, max}$ is exceeded, the load impedance R_L must be reduced accordingly by parallel connection of R:
 $f \leq 100 \text{ Hz}$: $R_{L, max} = 47 \text{ k}\Omega$
 $f \leq 1 \text{ kHz}$: $R_{L, max} = 10 \text{ k}\Omega$
 $f \leq 10 \text{ kHz}$: $R_{L, max} = 1 \text{ k}\Omega$
- The minimum load impedance $R_{L, min}$ is calculated as follows:
 $R_{L, min} = (U_{ext} - U_0) / I_{max}$
- X designates the connection terminals A, B or D, depending on the version of the signal converter.

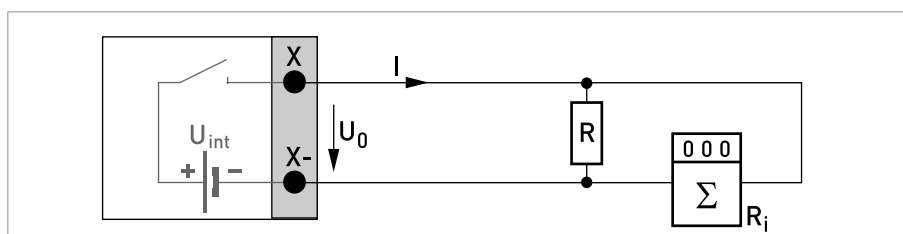
Figure 4-14: Pulse / frequency output active P_a

**INFORMATION!**

For frequencies above 100 Hz, shielded cables are to be used in order to reduce effects from electrical interferences (EMC).

Pulse/frequency output passive, modular I/Os

- $U_{\text{ext}} \leq 32 \text{ VDC}$
- f_{max} in the operating menu set to $f_{\text{max}} \leq 100 \text{ Hz}$:
 $I \leq 100 \text{ mA}$
 open:
 $I \leq 0.05 \text{ mA}$ at $U_{\text{ext}} = 32 \text{ VDC}$
 closed:
 $U_{0, \text{max}} = 0.2 \text{ V}$ at $I \leq 10 \text{ mA}$
 $U_{0, \text{max}} = 2 \text{ V}$ at $I \leq 100 \text{ mA}$
- f_{max} in operating menu set to $100 \text{ Hz} < f_{\text{max}} \leq 10 \text{ kHz}$:
 open:
 $I \leq 0.05 \text{ mA}$ at $U_{\text{ext}} = 32 \text{ VDC}$
 closed:
 $U_{0, \text{max}} = 1.5 \text{ V}$ at $I \leq 1 \text{ mA}$
 $U_{0, \text{max}} = 2.5 \text{ V}$ at $I \leq 10 \text{ mA}$
 $U_{0, \text{max}} = 5 \text{ V}$ at $I \leq 20 \text{ mA}$
- If the following maximum load impedance $R_{L, \text{max}}$ is exceeded, the load impedance R_L must be reduced accordingly by parallel connection of R:
 $f \leq 100 \text{ Hz}$: $R_{L, \text{max}} = 47 \text{ k}\Omega$
 $f \leq 1 \text{ kHz}$: $R_{L, \text{max}} = 10 \text{ k}\Omega$
 $f \leq 10 \text{ kHz}$: $R_{L, \text{max}} = 1 \text{ k}\Omega$
- The minimum load impedance $R_{L, \text{min}}$ is calculated as follows:
 $R_{L, \text{min}} = (U_{\text{ext}} - U_0) / I_{\text{max}}$
- Can also be set as status output; refer to status output connection diagram.
- X designates the connection terminals A, B or D, depending on the version of the signal converter.

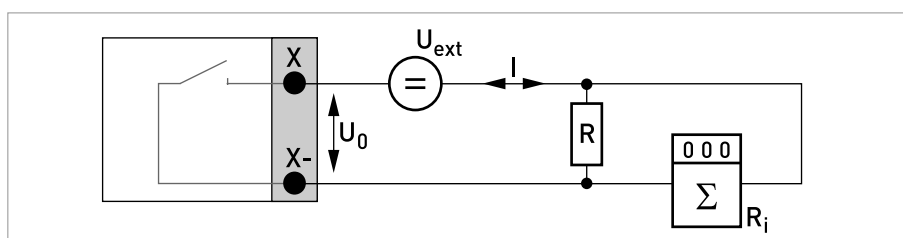

Figure 4-15: Pulse frequency output passive P_p

**INFORMATION!**

- For frequencies above 100 Hz, shielded cables are to be used in order to reduce effects from electrical interferences (EMC).
- **Compact and field housing versions:** Shield connected via the cable terminals in the terminal compartment.
Wall-mounted version: Shield connected using 6.3 mm / 0.25" push-on connectors (insulation to DIN 46245) in the terminal compartment.
- Any connection polarity.

Pulse and frequency output passive P_N NAMUR, modular I/O

- Connection in conformity with EN 60947-5-6
- open:
 $I_{nom} = 0.6 \text{ mA}$
- closed:
 $I_{nom} = 3.8 \text{ mA}$
- X designates the connection terminals A, B or D, depending on the version of the signal converter.

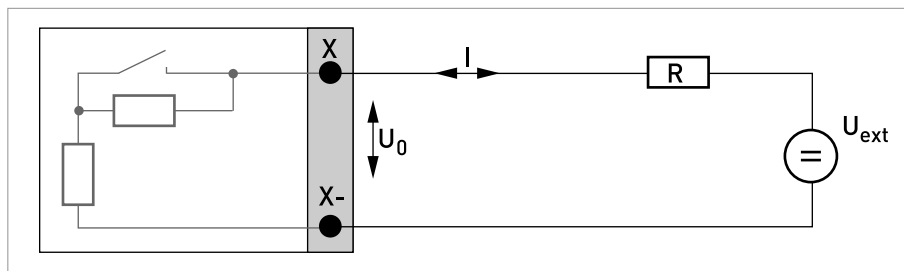
Figure 4-16: Pulse and frequency output passive P_N to NAMUR EN 60947-5-6

Status output / limit switch active, modular I/Os

- Observe connection polarity.
- $U_{\text{int}} = 24 \text{ VDC}$
- $I \leq 20 \text{ mA}$
- $R_L \leq 47 \text{ k}\Omega$
- open:
 $I \leq 0.05 \text{ mA}$
- closed:
 $U_{0, \text{nom}} = 24 \text{ V}$ at $I = 20 \text{ mA}$
- X designates the connection terminals A, B or D, depending on the version of the signal converter.

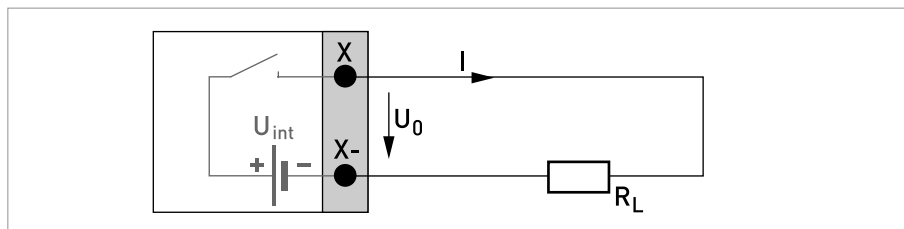
Figure 4-17: Status output / limit switch active S_a **Status output / limit switch passive, modular I/Os**

- Any connection polarity.
- $U_{\text{ext}} = 32 \text{ VDC}$
- $I \leq 100 \text{ mA}$
- $R_{L, \text{max}} = 47 \text{ k}\Omega$
 $R_{L, \text{min}} = (U_{\text{ext}} - U_0) / I_{\text{max}}$
- open:
 $I \leq 0.05 \text{ mA}$ at $U_{\text{ext}} = 32 \text{ VDC}$
- closed:
 $U_{0, \text{max}} = 0.2 \text{ V}$ at $I \leq 10 \text{ mA}$
 $U_{0, \text{max}} = 2 \text{ V}$ at $I \leq 100 \text{ mA}$
- The output is open when the device is de-energized.
- X designates the connection terminals A, B or D, depending on the version of the signal converter.

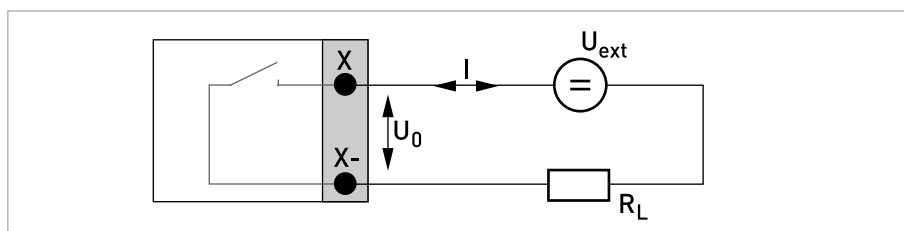
Figure 4-18: Status output / limit switch passive S_p

Status output / limit switch S_N NAMUR, modular I/Os

- Any connection polarity.
- Connection in conformity with EN 60947-5-6
- open:
 $I_{nom} = 0.6 \text{ mA}$
- closed:
 $I_{nom} = 3.8 \text{ mA}$
- The output is open when the device is de-energized.
- X designates the connection terminals A, B or D, depending on the version of the signal converter.

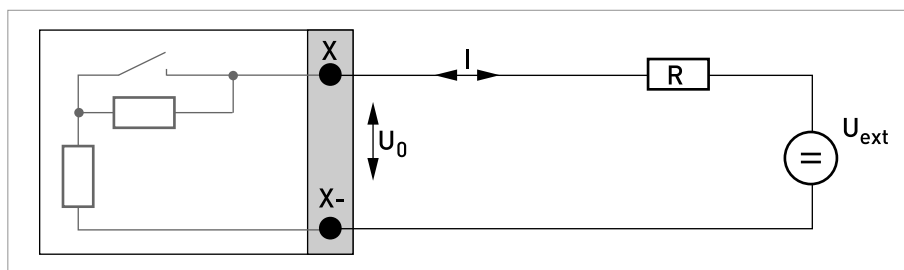

Figure 4-19: Status output / limit switch S_N to NAMUR EN 60947-5-6



CAUTION!

Observe connection polarity.

Control input active, modular I/Os

- $U_{int} = 24 \text{ VDC}$
- External contact open:
 $U_{0, nom} = 22 \text{ V}$
- External contact closed:
 $I_{nom} = 4 \text{ mA}$
- Switching point for identifying "contact open or closed":
Contact open (off): $U_0 \leq 10 \text{ V}$ with $I_{nom} = 1.9 \text{ mA}$
Contact closed (on): $U_0 \geq 12 \text{ V}$ with $I_{nom} = 1.9 \text{ mA}$
- X designates the connection terminals A or B, depending on the version of the signal converter.

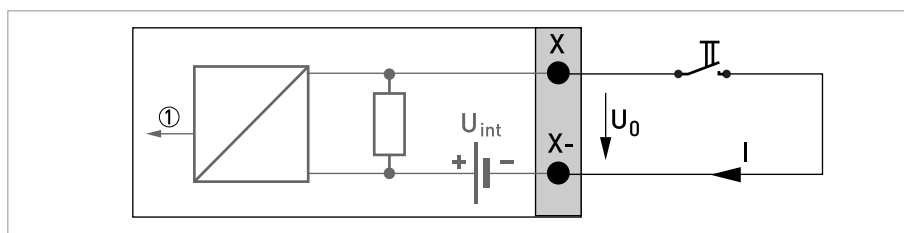

Figure 4-20: Control input active C_a

① Signal

Control input passive, modular I/Os

- $3 \text{ V} \leq U_{\text{ext}} \leq 32 \text{ VDC}$
- $I_{\text{max}} = 9.5 \text{ mA}$ at $U_{\text{ext}} \leq 24 \text{ V}$
 $I_{\text{max}} = 9.5 \text{ mA}$ at $U_{\text{ext}} \leq 32 \text{ V}$
- Switching point for identifying "contact open or closed":
 Contact open (off): $U_0 \leq 2.5 \text{ V}$ with $I_{\text{nom}} = 1.9 \text{ mA}$
 Contact closed (on): $U_0 \geq 3 \text{ V}$ with $I_{\text{nom}} = 1.9 \text{ mA}$
- X designates the connection terminals A or B, depending on the version of the signal converter.

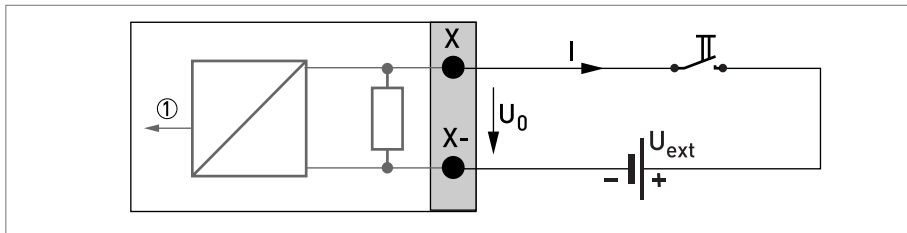

Figure 4-21: Control input passive C_p

① Signal



CAUTION!

Observe connection polarity.

Control input active C_N NAMUR, modular I/Os

- Connection acc. to EN 60947-5-6
- Switching point for identifying "contact open or closed":
 Contact open (off): $U_{0, \text{nom}} = 6.3 \text{ V}$ with $I_{\text{nom}} < 1.9 \text{ mA}$
 Contact closed (on): $U_{0, \text{nom}} = 6.3 \text{ V}$ with $I_{\text{nom}} > 1.9 \text{ mA}$
- Detection of cable break:
 $U_0 \geq 8.1 \text{ V}$ with $I \leq 0.1 \text{ mA}$
- Detection of cable short circuit:
 $U_0 \leq 1.2 \text{ V}$ with $I \geq 6.7 \text{ mA}$
- X designates the connection terminals A or B, depending on the version of the signal converter.

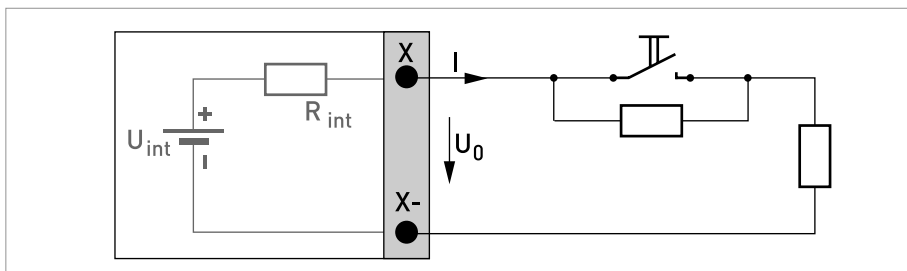

Figure 4-22: Control input active C_N to NAMUR EN 60947-5-6

Current input active, modular I/Os

- $U_{\text{int, nom}} = 24 \text{ VDC}$
- $I \leq 22 \text{ mA}$
- $I_{\text{max}} \leq 26 \text{ mA}$ (electronically limited)
- $U_{0, \text{min}} = 19 \text{ V}$ at $I \leq 22 \text{ mA}$
- **no HART®**
- X designates the connection terminals A or B, depending on the version of the signal converter.

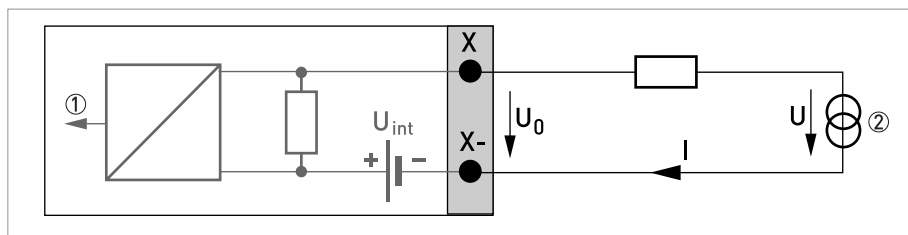

Figure 4-23: Current input active IIn_a

- ① Signal
- ② 2-wire transmitter (e.g. temperature)

Current input passive, modular I/Os

- $U_{\text{ext}} \leq 32 \text{ VDC}$
- $I \leq 22 \text{ mA}$
- $I_{\text{max}} \leq 26 \text{ mA}$
- $U_{0, \text{max}} = 5 \text{ V}$ at $I \leq 22 \text{ mA}$
- X designates the connection terminals A or B, depending on the version of the signal converter.

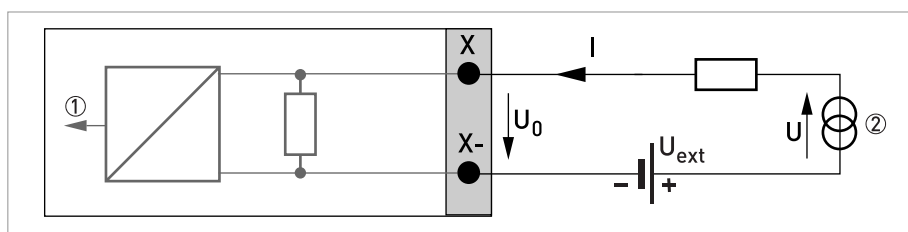

Figure 4-24: Current input passive IIn_p

- ① Signal
- ② 2-wire transmitter (e.g. temperature)

4.8.5 Ex i inputs/outputs

**DANGER!**

For devices used in hazardous areas, additional safety notes apply; please refer to the Ex documentation.

**INFORMATION!**

For further information on electrical connection refer to Description of the inputs and outputs on page 31.

Current output active (only current output terminals C/C- have HART[®] capability), Ex i I/Os

- Observe connection polarity.
- $U_{\text{int, nom}} = 20 \text{ VDC}$
- $I \leq 22 \text{ mA}$
- $R_L \leq 450 \Omega$
- X designates the connection terminals A or C, depending on the version of the signal converter.

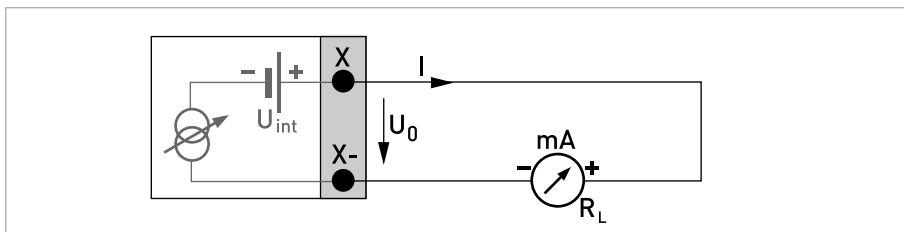

Figure 4-25: Current output active I_a Ex i

Current output passive (only current output terminals C/C- have HART[®] capability), Ex i I/Os

- Any connection polarity.
- $U_{\text{ext}} \leq 32 \text{ VDC}$
- $I \leq 22 \text{ mA}$
- $U_0 \geq 4 \text{ V}$
- $R_{L, \text{max}} = (U_{\text{ext}} - U_0) / I_{\text{max}}$
- X designates the connection terminals A or C, depending on the version of the signal converter.

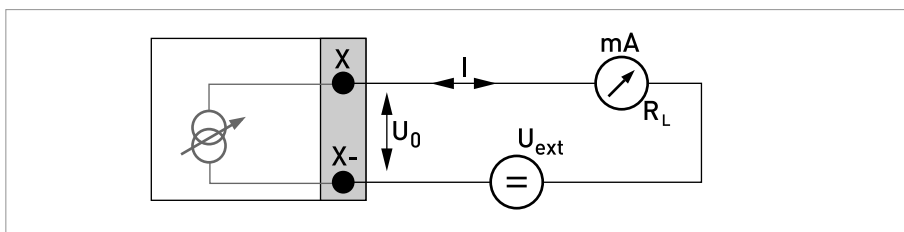

Figure 4-26: Current output passive I_p Ex i

**DANGER!**

For devices used in hazardous areas, additional safety notes apply; please refer to the Ex documentation.

**INFORMATION!**

- For frequencies above 100 Hz, shielded cables are to be used in order to reduce effects from electrical interferences (EMC).
- **Compact and field housing versions:** Shield connected via the cable terminals in the terminal compartment.
- **Wall-mounted version:** Shield connected using 6.3 mm / 0.25" push-on connectors (insulation to DIN 46245) in the terminal compartment.
- Any connection polarity.

Pulse and frequency output passive P_N NAMUR, Ex i I/Os

- Connection acc. to EN 60947-5-6
- open:
 $I_{nom} = 0.43 \text{ mA}$
- closed:
 $I_{nom} = 4.5 \text{ mA}$
- X designates the connection terminals B or D, depending on the version of the signal converter.

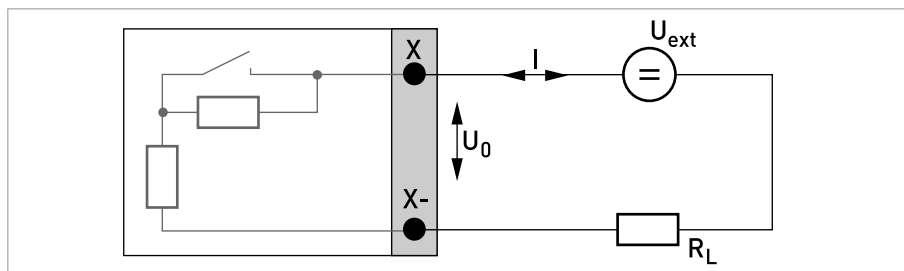

Figure 4-27: Pulse/frequency output passive P_N to NAMUR EN 60947-5-6 Ex i

**INFORMATION!**

- Any connection polarity.

Status output/limit switch S_N NAMUR, Ex i I/Os

- Connection acc. to EN 60947-5-6
- open:
 $I_{nom} = 0.43 \text{ mA}$
- closed:
 $I_{nom} = 4.5 \text{ mA}$
- The output is closed when the device is de-energized.
- X designates the connection terminals B or D, depending on the version of the signal converter.

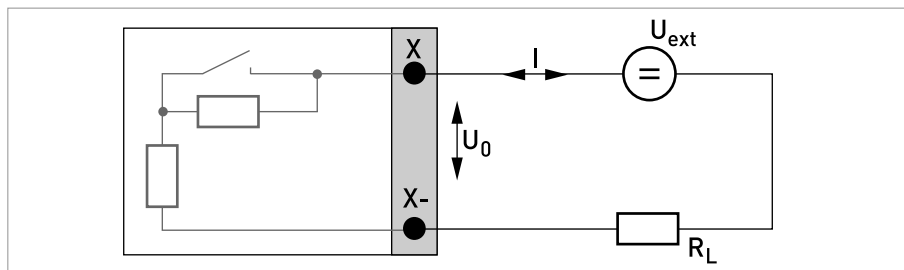

Figure 4-28: Status output / limit switch S_N to NAMUR EN 60947-5-6 Ex i

**DANGER!**

For devices used in hazardous areas, additional safety notes apply; please refer to the Ex documentation.

**INFORMATION!**

- Any connection polarity.

Control input passive, Ex i I/Os

- $5.5 \text{ V} \leq U_{\text{ext}} \leq 32 \text{ VDC}$
- $I_{\text{max}} = 6 \text{ mA}$ at $U_{\text{ext}} \leq 24 \text{ V}$
 $I_{\text{max}} = 6.5 \text{ mA}$ at $U_{\text{ext}} \leq 32 \text{ V}$
- Switching point for identifying "contact open or closed":
 Contact open (off): $U_0 \leq 3.5 \text{ V}$ with $I \leq 0.5 \text{ mA}$
 Contact closed (on): $U_0 \geq 5.5 \text{ V}$ with $I \geq 4 \text{ mA}$
- X designates the connection terminals B, if available.

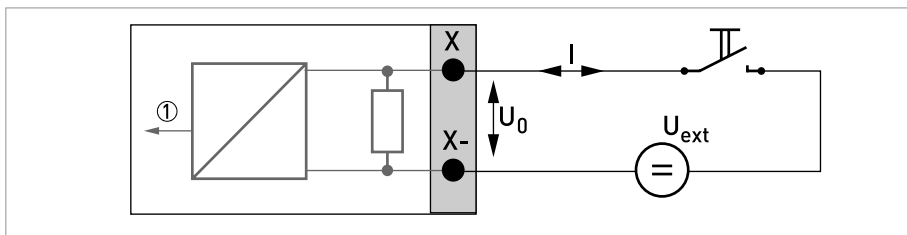

Figure 4-29: Control input passive C_p Ex i

- ① Signal

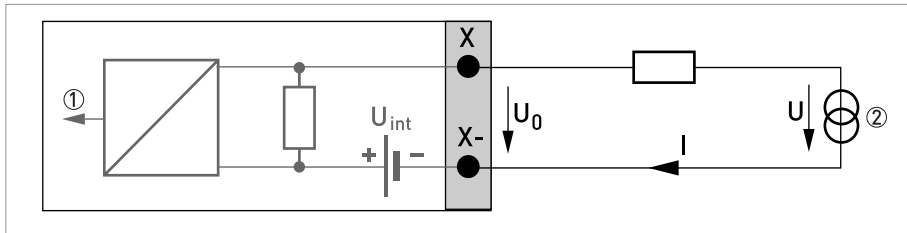

Figure 4-30: Current input active IIn_a

- ① Signal
- ② 2-wire transmitter (e.g. temperature)

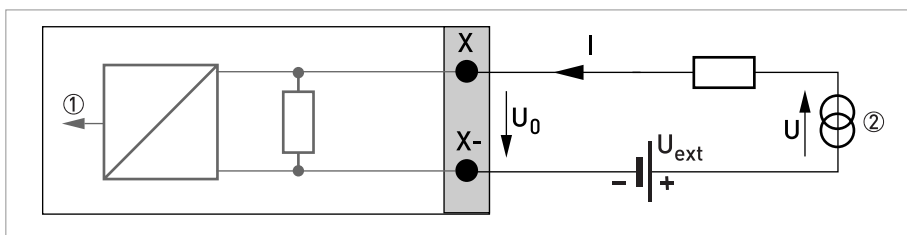

Figure 4-31: Current input passive IIn_p

- ① Signal
- ② 2-wire transmitter (e.g. temperature)

4.8.6 HART[®] connection



INFORMATION!

- In the basic I/O the current output at connection terminals A+/A-/A always has HART[®] capability.
- For modular I/O and Ex i I/O, only the output module for the connection terminals C/C- has HART[®] capability.

HART[®] connection active (point-to-point)

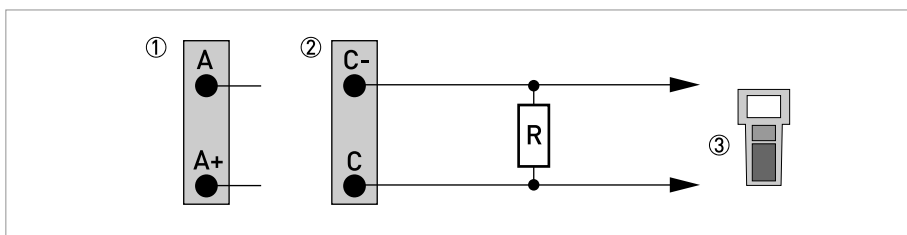

Figure 4-32: HART[®] connection active (I_a)

- ① Basic I/O: terminals A and A+
- ② Modular I/O: terminals C- and C
- ③ HART[®] communicator

The parallel resistance to the HART[®] communicator must be $R \geq 230 \Omega$.

HART[®] connection passive (Multi-Drop mode)

- $I: I_{0\%} \geq 4 \text{ mA}$
- Multi-Drop mode I: $I_{\text{fix}} \geq 4 \text{ mA} = I_{0\%}$
- $U_{\text{ext}} \leq 32 \text{ VDC}$
- $R \geq 230 \Omega$

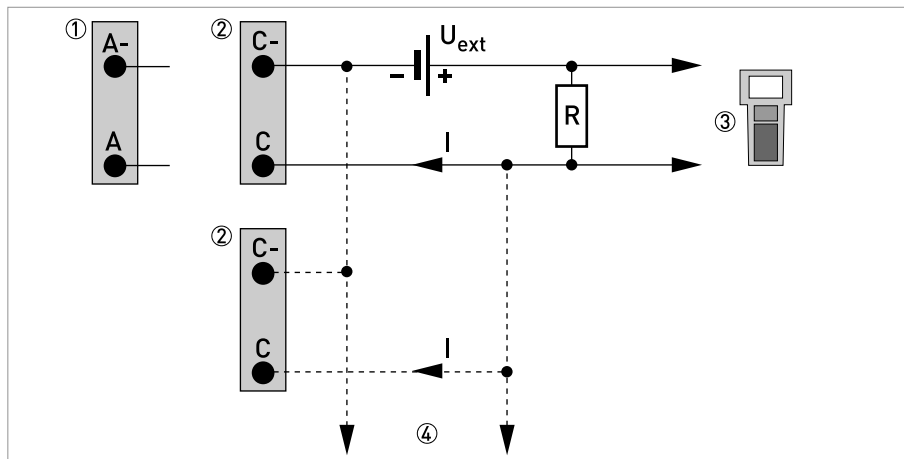

Figure 4-33: HART[®] connection passive (I_p)

- ① Basic I/O: terminals A- and A
- ② Modular I/O: terminals C- and C
- ③ HART[®] communicator
- ④ Other devices with HART[®] capability

5.1 Switching on the power

Before connecting to power, please check that the system has been correctly installed. This includes:

- The device must be mechanically safe and mounted in compliance with the regulations.
- The power connections must have been made in compliance with the regulations.
- The electrical terminal compartments must be secured and the covers have been screwed on.
- Check that the electrical operating data of the power supply are correct.



- Switching on the power.

5.2 Starting the signal converter

The measuring device, consisting of the measuring sensor and the signal converter, is supplied ready for operation. All operating data have been set at the factory in accordance with your order specifications.

When the power is switched on, a self test is carried out. After that the device immediately begins measuring, and the current values are displayed.

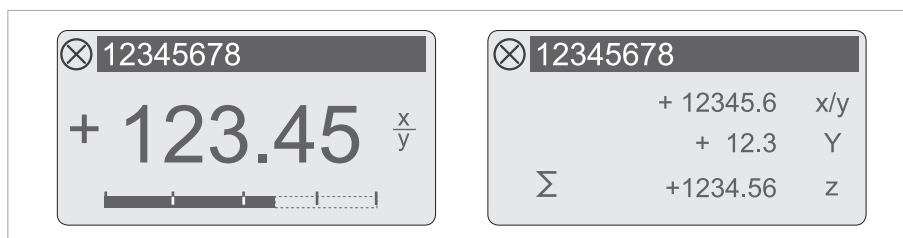

Figure 5-1: Displays in measuring mode (examples for 2 or 3 measured values)
x, y and z denote the units of the measured values displayed

It is possible to change between the two measured value windows, the trend display and the list with the status messages by pressing the keys \uparrow and \downarrow .

6.1 Display and operating elements

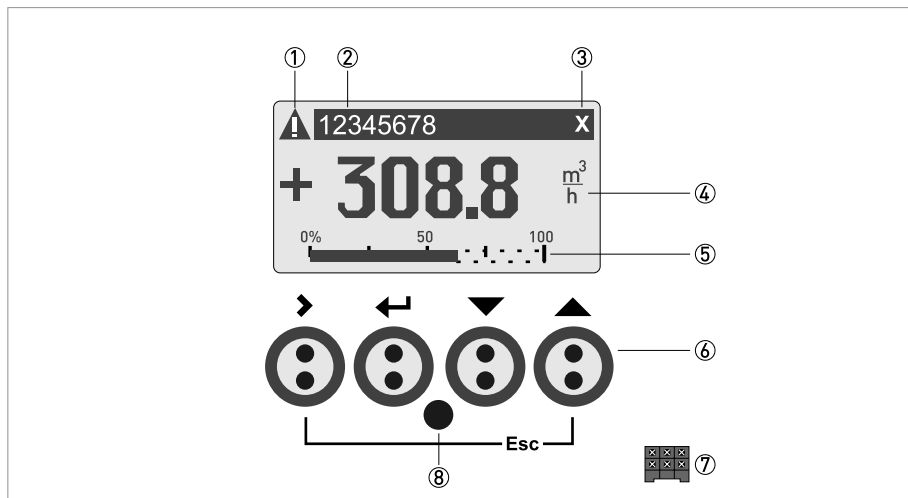

Figure 6-1: Display and operating elements (Example: flow indication with 2 measuring values)

- ① Indicates a possible status message in the status list
- ② Tag number (is only indicated if this number was entered previously by the operator)
- ③ Indicates when a key has been pressed
- ④ 1st measured variable in large representation
- ⑤ Bargraph indication
- ⑥ Keys (see table below for function and representation in text)
- ⑦ Interface to the GDC bus (not present in all signal converter versions)
- ⑧ Infrared sensor (not present in all signal converter versions)



CAUTION!

The use of a jumper is only permitted for custody transfer devices to lock the access to custody transfer relevant parameters. For non custody transfer devices (i.e. process instruments) this jumper must not be used!



INFORMATION!

- The switching point for the 4 optical keys is located directly in front of the glass. It is recommended to activate the keys at right angles to the front. Touching them from the side can cause incorrect operation.
- After 5 minutes of inactivity, there is an automatic return to measuring mode. Previously changed data is not saved.

Key	Measuring mode	Menu mode	Submenu or function mode	Parameter and data mode
>	Switch from measuring mode to menu mode; press key for 2.5 s, "Quick Start" menu is then displayed	Access to displayed menu, then 1st submenu is displayed	Access to displayed submenu or function	For numerical values, move cursor (highlighted in blue) one position to the right
↵	Reset of display	Return to measuring mode but prompt whether the data should be saved	Press 1 to 3 times, return to menu mode, data saved	Return to submenu or function, data saved
↓ or ↑	Switch between display pages: measured value 1 + 2, trend page and status page(s)	Select menu	Select submenu or function	Use cursor highlighted in blue to change number, unit, setting and to move the decimal point
Esc (> + ↑)	-	-	Return to menu mode without acceptance of data	Return to submenu or function without acceptance of data

Table 6-1: Description of key functionality

6.1.1 Display in measuring mode with 2 or 3 measured values

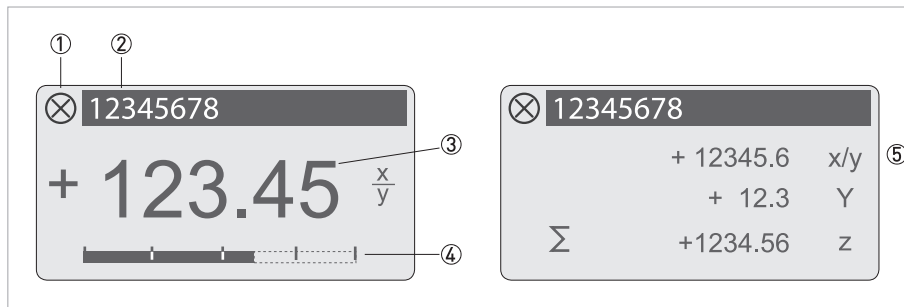

Figure 6-2: Example for display in measuring mode with 2 or 3 measured values

- ① Indicates a possible status message in the status list
- ② Tag number (is only indicated if this number was entered previously by the operator)
- ③ 1st measured variable in large depiction
- ④ Bargraph indication
- ⑤ Depiction with 3 measured values

6.1.2 Display for selection of sub-menu and functions, 3 lines

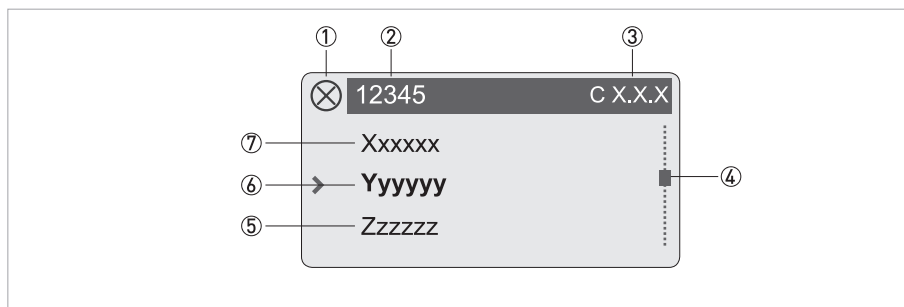

Figure 6-3: Display for selection of submenu and functions, 3 lines

- ① Indicates a possible status message in the status list
- ② Menu, submenu or function name
- ③ Number relating to ⑥
- ④ Indicates position within menu, submenu or function list
- ⑤ Next menu(s), submenu or function
[___ signalise in this line the end of the list]
- ⑥ Current menu(s), submenu or function
- ⑦ Previous menu(s), submenu or function
[___ signalise in this line the beginning of the list]

6.1.3 Display when setting parameters, 4 lines

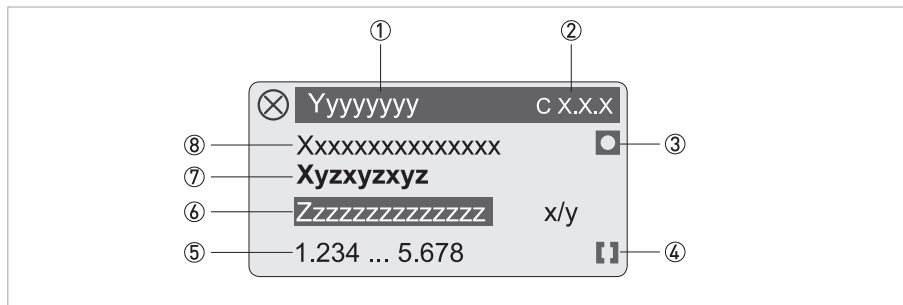

Figure 6-4: Display when setting parameters, 4 lines

- ① Current menu(s), submenu or function
- ② Number relating to ⑦
- ③ Denotes factory setting
- ④ Denotes permissible value range
- ⑤ Permissible value range for numeric values
- ⑥ Currently set value, unit or function (when selected, appears with white text, blue background)
This is where the data is changed.
- ⑦ Current parameter
- ⑧ Factory setting of parameter

6.1.4 Display when previewing parameters, 4 lines

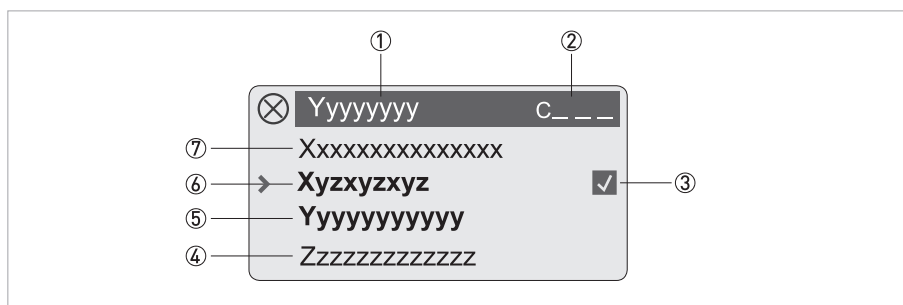

Figure 6-5: Display when previewing parameters, 4 lines

- ① Current menu(s), submenu or function
- ② Number relating to ⑥
- ③ Denotes a changed parameter (simple check of changed data when browsing through lists)
- ④ Next parameter
- ⑤ Currently set data from ⑥
- ⑥ Current parameter (for selection press key >; then see previous chapter)
- ⑦ Factory setting of parameter

6.1.5 Using an IR interface (option)

The optical IR interface serves as an adapter for PC-based communication with the signal converter without opening the housing.



INFORMATION!

- *This device is not part of the scope of delivery.*
- *For more information about activation with the functions A6 or .*

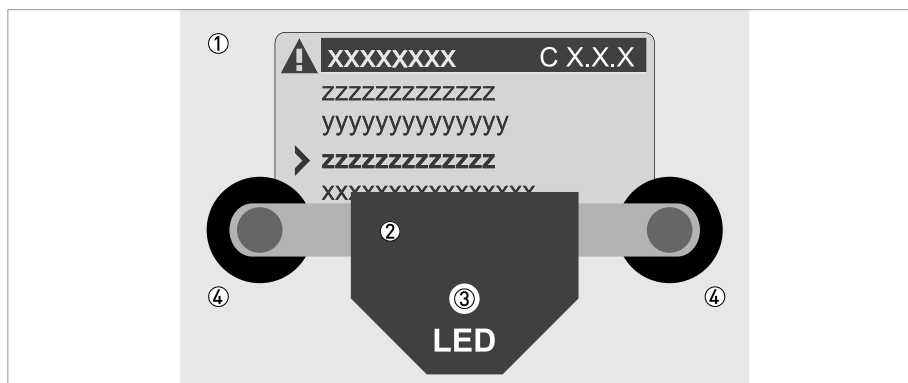

Figure 6-6: IR interface

- ① Glass panel in front of the control and display panel
- ② IR interface
- ③ LED lights up when IR interface is activated.
- ④ Suction cups

Timeout function

Following activation of the IR interface in Fct. A6 or the interface must be properly positioned and attached to the housing with the suction cups within 60 seconds. If this does not happen within the specified time period, the device can be operated using the optical keys again. Upon activation, the LED ③ lights up and the optical keys no longer function.

6.2 Menu overview

Measuring mode	Select menu	Select menu and/or sub-menu	Select function and set data
←	Press > 2.5 s		
	A quick setup	> A1 language ← A2 tag A3 reset > A3.1 reset errors ← A3.2 counter 1 A3.3 counter 2 A3.4 counter 3 A4 GDC IR interface	> ← > ← > ← > ←
	↓ ↑	↓ ↑	↓ ↑ >

Measuring mode	Select menu	Select menu and/or sub-menu	Select function and set data
←	Press > 2.5 s		
	B test	> B1 simulation <← > B2 actual values <← > B3 information <←	> B1.1 volume flow <← B1.2 velocity of sound B1.□ current in X B1.□ current out X B1.□ pulse out X B1.□ frequency output X B1.□ control input X B1.□ limit switch X B1.□ status output X > B2.1 act. volume flow <← B2.2 act. corrected flow ① B2.3 act. enthalpy flow ② B2.4 act. mass flow B2.5 act. molar mass ① B2.6 act. specific enthalpy ② B2.7 act. density ② B2.8 act. dynamic viscosity ② B2.9 act. flow speed B2.10 act. vel. of sound B2.11 act. gain B2.12 act. SNR B2.13 act. pressure B2.14 act. temperature B2.15 current in A B2.16 current in B B2.17 operating hours > B3.1 C number <← B3.2 process input B3.3 SW.REV.MS B3.4 SW.REV.UIS B3.6 Electronic Revision ER
	↓↑	↓↑	↓↑ >

① Gas flow option

② Steam flow option

Measuring mode	Select menu	Select menu and/or sub-menu	Select function and set data
←	Press > 2.5 s		
	C setup	> C1 process input <← > C1.1 meter size <← C1.2 calibration C1.3 filter C1.4 plausibility C1.5 simulation C1.6 information C1.7 monitor VoS ① C1.8 monitor settings ① C1.9 linearization C1.10 adiabatic index ② C1.11 P & T correction ② C1.12 P & T inputs ② C1.13 pipe temperature ② C1.14 pipe pressure ② C1.15 density ② C1.16 diagnosis value > C2 I/O (input/output) <← C2.1 hardware C2.□ current input X C2.□ current output X C2.□ frequency output X C2.□ pulse output X C2.□ status output X C2.□ limit switch X C2.□ control input X > C3 I/O counter <← C3.1 counter 1 C3.2 counter 2 C3.3 counter 3 > C4 I/O HART <← C4.1 PV is C4.2 SV is C4.3 TV is C4.4 4V is C4.5 HART units	> <←
	↓ ↑	↓ ↑	↓ ↑ >

① Steam flow option

② Gas flow option

Measuring mode		Select menu	Select menu and/or sub-menu			Select function and set data
←	C setup	>	C5 device	>	C5.1 device info	>
		↵		↵	C5.2 display	↵
					C5.3 1. meas. page	
					C5.4 2. meas. page	
					C5.5 graphic page	
					C5.6 special functions	
					C5.7 units	
					C5.8 HART	
					C5.9 quick setup	
	↓ ↑		↓ ↑		↓ ↑	↓ ↑ >

6.3 Function tables



INFORMATION!

- The following tables describe the functions of the standard device with HART® connection. The functions for Modbus, Foundation Fieldbus and Profibus are described in detail in the corresponding supplementary instructions.
- Depending on the device version, not all functions are available.

6.3.1 Menu A, quick setup

No.	Function	Settings / descriptions
A1	language	Select: English / Français / Deutsch
A2	tag	Measuring point identifier (Tag no.) (also for HART® operation), appears in the LCD display header (up to 8 digits).
A3	reset	
A3.1	reset errors	Reset? Select: no/yes
A3.2	counter 1	Reset counter? Select: no / yes (available if activated in C5.9.1)
A3.3	counter 2	Reset counter? Select: no / yes (available if activated in C5.9.2)
A3.4	counter 3	Reset counter? Select: no / yes (available if activated in C5.9.3)
A4	GDC IR interface	This function requires an optical GDC adapter connected to the LCD display. After 60 seconds without a connection being established or after the adapter is removed, the function is exited and the optical keys are active again.
		Select: break (exit function without connection)
		Activate (the IR interface adapter and interrupt the optical keys)

6.3.2 Menu B, test

No.	Function	Settings / descriptions
simulation		
B1	simulation	Displayed values are simulated.
B1.1	volume flow	Volume flow simulation.
		1. Set value; unit selection in Fct. C5.7.2 / Cancel (exit function without simulation) 2. Query: start simulation? no (exit function without simulation) / yes (start simulation)
B1.2	velocity of sound	Velocity of sound simulation, sequence and settings similar to B1.1, see above!
		X stands for one of the connection terminals A, B, C or D.
		<input type="checkbox"/> stands for Fct. no. B1.3...1.6.
B1. <input type="checkbox"/>	current in X	Simulation X
		X stands for one of the connection terminals A, B, C or D.
		Sequence and settings similar to B1.1, see above!
		The pulse setting is provided at the output during one second.
B1. <input type="checkbox"/>	current out X	
B1. <input type="checkbox"/>	pulse out X	
B1. <input type="checkbox"/>	frequency output X	
B1. <input type="checkbox"/>	control input X	
B1. <input type="checkbox"/>	limit switch X	
B1. <input type="checkbox"/>	status output X	

actual values

B2	actual values	Display the current values; exit the displayed function with key ←
B2.1	act. volume flow	
B2.2	act. corrected flow	Gas flow option
B2.3	act. enthalpy flow	Steam flow option
B2.4	act. mass flow	
B2.5	act. molar mass	Gas flow option
B2.6	act. specific enthalpy	Steam flow option
B2.7	act. density	Steam flow option
B2.8	act. dynamic viscosity	Steam flow option
B2.9	act. flow speed	
B2.10	act. vel. of sound	Select: path 1 or path 2
B2.11	act. gain	Select: path 1 or path 2
B2.12	act. SNR	Select: path 1 or path 2
B2.13	act. pressure	
B2.14	act. temperature	
B2.15	current in A	Current input terminal A
B2.16	current in B	Current input terminal B
B2.17	operating hours	

information

B3	information	
B3.1	C number	CG number, non-alterable (input/output version)
B3.2	process input	Process input section
		Select: sensor CPU / sensor DSP / sensor driver
		1 st line: ID No. of the circuit board
		2 nd line: software version
		3 rd line: production date
B3.3	SW.REV.MS	Software Revision Main Software
		1 st line: ID No. of the circuit board
		2 nd line: software version
		3 rd line: production date
B3.4	SW.REV. UIS	Software revision User Interface Software
		1 st line: ID No. of the circuit board
		2 nd line: software version
		3 rd line: production date
B3.6	Electronic Revision ER	Electronic Revision HART® & Software
		1 st line: ID No. of the circuit board
		2 nd line: software version
		3 rd line: production date

6.3.3 Menu C, setup

No.	Function	Settings / descriptions
C1 process input		
C1.1	meter size	Select from size table. Range: DN25...1000 mm / 1...40"
C1.2	calibration	
C1.2.1	zero calibration	Display of current zero calibration value. Query: calibrate zero? Setting: cancel / automatic / default Automatic (shows the current value as the new zero calibration value).
C1.2.2	GK	Select GK value (see nameplate of the measuring sensor). Range: 0.5000...10.000
C1.3	filter	
C1.3.1	limitation	Limitation of all flow values, before smoothing by time constant, affects all outputs. Range: -100.0...+100.0 m/s
C1.3.2	flow direction	Define polarity of flow direction. Select: normal (according to the arrow on the measuring sensor) / backwards (in the opposite direction to the arrow)
C1.3.3	time constant	Averages measurement Increasing value improves stability but delays the reaction. Master setting, overrules time constant settings of all outputs. xxx.x s Range: 0.0...100 s
C1.3.4	low flow cutoff	Sets output value of all outputs to zero. "0" appears in display. x.xxx ± x.xxx m/s Range: 0.0...10 m/s 1 st value = switching point / 2 nd value = hysteresis Condition: 2 nd value ≤ 1 st value
C1.4	plausibility	Changes in values outside error limit are only accepted when number of measurements exceeds counter limit (C1.4.3).
C1.4.1	error limit	Measurement is ignored if value exceeds the error limit. One ignored value = counter +1. Measurements within the error limit decrease the counter (see C1.4.2). Range: 0...100%
C1.4.2	counter decrease	Multiplier for every measurement within the error limit to decrease the counter. Range: 01...99
C1.4.3	counter limit	Above this value measurements will not be ignored. Range: 000...999
C1.5	simulation	
C1.5.1	volume flow	Query: sim. volume flow. Select: cancel / set value (select value, start simulation? yes / no).

C1.5.2	velocity of sound	Query: sim. velocity of sound.
		Select: cancel / set value
		Range: 200.00...1100.0 (start simulation? yes / no)
C1.6	information	
C1.6.1	sensor CPU	Identification of hardware and software for flow processing.
		1 st line: ID No. of the circuit board
		2 nd line: software version
		3 rd line: production date
C1.6.2	sensor DSP	Identification of hardware and software for signal processing.
		1 st line: ID No. of the circuit board
		2 nd line: software version
		3 rd line: production date
C1.6.3	sensor driver	Identification of hardware and software for driver part.
		1 st line: ID No. of the circuit board
		2 nd line: software version
		3 rd line: production date
C1.6.4	calibration date	Format: yyyy-mm-dd
C1.6.5	serial no. sensor	
C1.6.6	v no. sensor	
C1.7	monitor VoS	Steam flow option
		Select: on (start sequence C1.8) / off
C1.8	monitor settings	Steam flow option
		Select (start sequence C1.8.1 to 1.8.5)
C1.8.1	matching factor	Steam flow option
		Active ratio between measured and calculated VoS.
C1.8.2	act. ratio meas./ cal.	Steam flow option
		Actual ratio between measured and calculated VoS (not active).
C1.8.3	new match?	Steam flow option
		Select: yes (programm new matching factor) / no
		Range: 0.50...2.00 value will change C1.8.1
C1.8.4	VoS tolerance	Steam flow option
		If difference between matching factor and act. ratio meas./ cal. exceeds this value activates error message.
		Range: 00...25%
C1.8.5	time constant	Steam flow option
		Averages measurement.
		Increasing value improves stability but delays the reaction.
		Range: 0060...3600 s
C1.9	linearization	Correction for non linear deviations of the output.
		Select: start sequence C1.9.1
C1.9.1	linearization	Select: on / off

C1.9.2	dynamic viscosity	Gas flow option
		Only available if 'on' is selected in C1.9.1
		Select value
		Range: 0.500...50.00 $\mu\text{Pa}\cdot\text{s}$
C1.10	adiabatic index	Gas flow option
		Value for adiabatic index.
		Select value
		Range: 1.0000...2.0000
C1.11	P & T correction	Gas flow option
		Compensation for thermal and pressure expansion of the sensor.
		Select: Normal / None / OPEC / IUPAC / Old Normal (activates options C1.12 to C1.15)
		Calculation of gasflow to standard conditions using input of a temperature and a pressure transmitter.
		P&T correction Normal: calculation to 0°C and 101.325 kPa (DIN 1343)
		P&T correction Old Normal: calculation to 15°C and 101.325 kPa (DIN 1343)
		P&T correction IUPAC: calculation to 0°C and 100 kPa
		P&T correction OPEC: calculation to 60°F and 14.73 psi
		Compensation of flow tube expansion / contraction due to temperature and pressure variation. Before entering C1.15 (density), first save the setting and leave the menu.
C1.12	P & T inputs	Gas flow option
		Select: automatic / fixed
		Automatic: using input from connected pressure and temperature transmitters
		Fixed: manual fixed temperature and pressure setting via menu option C1.13 / C1.14
C1.13	temperature	Gas flow option
		Only available if 'fixed' is selected in C1.12
		Process temperature
		Select value Range: -40.00...+800°C
C1.14	pressure	Gas flow option
		Only available if 'fixed' is selected in C1.12
		Process pressure
		Select value Range: 1.00...250.00 bara
C1.15	density	Gas flow option
		Before entering first save the setting in C1.11 and leave the menu.
		Select value for density at reference conditions as selected in C1.11
C1.16	diagnosis value	
C1.16.1	diagnostics 1	Select: none / SNR 1 / gain 1 / velocity of sound 1
C1.16.2	diagnostics 2	Select: none / SNR 2 / gain 2 / velocity of sound 2
C1.16.3	diagnostics 3	Select: none / SNR 3 / gain 3 / velocity of sound 3

C2 inputs/outputs (I/Os)

C2.1	hardware	Assignment of connection terminals dependent on signal converter version: active / passive / NAMUR
C2.1.1	terminal A	Select: off (switched off) / current output / frequency output / pulse output / status output / limit switch / control input / current input (for pressure)
C2.1.2	terminal B	Select: off (switched off) / current output / frequency output / pulse output / status output / limit switch / control input / current input (for temperature)
C2.1.3	terminal C	Select: off (switched off) / current output / status output / limit switch
C2.1.4	terminal D	Select: off (switched off) / frequency output / pulse output / status output / limit switch

current input X

C2.□	current input X	Only available if terminal A and B are current input.
		X stands for one of the connection terminals A or B.
		□ stands for A or B.
C2.□.1	range 0%...100%	Current range for the selected measured variable, e.g. 4...20 mA, corresponds to 0...100%.
		xx.x ... xx.x mA
		Range: 04.0...20.0 mA
		Condition: 4 mA ≤ 1 st value ≤ 2 nd value ≤ 20 mA
C2.□.2	extended range	Exceeding the min. and max. limits.
		xx.x ... xx.x mA
		Range: 00.5...23 mA
		Condition: 0.5 mA ≤ 1 st value ≤ 2 nd value ≤ 23 mA
C2.□.3	measurement	Terminal A: pressure
		Terminal B: temperature
C2.□.4	range	Terminal A
		Range: 1.00...250.00 bara assumes absolute pressure e.g. when an pressure sensor 0-10 barg is used, set range to 1..11 Bar
		Terminal B
		Range: -40.00...+800.0°C
		0...xx.xx _ _ _ (format and unit depend on the measured variable, see above)
C2.□.5	time constant	Averages measurement
		Increasing value improves stability but delays the reaction.
		Range: 000.2...100.0 s
C2.□.6	information	1 st line: serial number of the I/O circuit board
		2 nd line: software version number
		3 rd line: production date of the circuit board
C2.□.7	simulation	Select: cancel / set value
		Terminal A
		Range: 1.00...250.00 bara
		Terminal B
		Range: -40.0...+800.0 °C

C2.□.8	4mA trimming	Trimming of the current at 4 mA
		Range: 3.6000...5.5000 mA
		Reset to 4 mA restores the factory calibration.
		Used for HART [®] setting.
C2.□.9	20mA trimming	Trimming of the current at 20 mA
		18.500...21.500 mA
		Reset to 20 mA restores the factory calibration.
		Used for HART [®] setting.

current output X

C2.□	current output X	X stands for one of the connection terminals A, B or C.
		□ stands for A, B or C.
C2.□.1	range 0%...100%	Current range for the selected measured variable, e.g. 4...20 mA, corresponds to 0...100%.
		xx.x ... xx.x mA
		Range: 0.00...20 mA
		Condition: 0 mA ≤ 1 st value ≤ 2 nd value ≤ 20 mA
C2.□.2	extended range	Exceeding the min. and max. limits.
		xx.x ... xx.x mA
		Range: 03.5...21.5 mA
		Condition: 3.5 mA ≤ 1 st value ≤ 2 nd value ≤ 21.5 mA
C2.□.3	error current	In case of error, this selected current is set.
		xx.x mA
		Range: 3...22 mA (condition: outside of extended range)
C2.□.4	error condition	The following error conditions can be selected.
		Select: error in device (error category [F]) / application error (error category [F]) / out of specification (error category [S])
C2.□.5	measurement	Measurements for activating the output.
		Select: volume flow / enthalpy flow / mass flow / specific enthalpy / density / flow speed / velocity of sound / gain / diagnostics 1, 2, 3
C2.□.6	range	0...100% of the measurement set in Fct. C2.□.5
		0...xx.xx _ _ _ (format and unit depend on the measured variable, see above)
C2.□.7	polarity	Set polarity of current output, please note flow direction in C1.3.2!
		Select: both polarities (plus and minus values are displayed) / positive polarity (display for negative values = 0) / negative polarity (display for positive values = 0) / absolute value (use for the output)
C2.□.8	limitation	Set lower and upper limit for current output before applying the time constant (see Fct. C2.□.10).
		±xxx ... ±xxx%
		Range: -150...+150%
C2.□.9	low flow cutoff	Below set value, current output is set to zero.
		x.xxx ± x.xxx%
		Range: 0.0...20%
		1 st value = switching point / 2 nd value = hysteresis
		Condition: 2 nd value ≤ 1 st value

C2.□.10	time constant	Averages measurement
		Increasing value improves stability but delays the reaction.
		Range: 000.1...100.0 s
C2.□.11	special function	When activated, changing the scale improves the resolution.
		Select:
		Off (switched off)
		Automatic range (scale changes to extended automatically for the threshold with hysteresis. Switching from one to another scale requires activation by a status output)
C2.□.12	threshold	External range (scale changes to extended range by control input)
		Appears only when Fct. C2.□.11 is activated.
		Set lag value between normal and extended range. The automatic range function always changes from the extended to the normal range when the 100% current is reached.
C2.□.13	information	Range: 05.0...80%
		1 st line: serial number of the I/O circuit board
		2 nd line: software version number
C2.□.14	simulation	3 rd line: production date of the circuit board
		Sequence see B1.□ current output X
C2.□.15	4mA trimming	Trimming of the current at 4 mA
		Reset to 4 mA restores the factory calibration.
		Used for HART [®] setting.
C2.□.16	20mA trimming	Trimming of the current at 20 mA
		Reset to 20 mA restores the factory calibration.
		Used for HART [®] setting.

frequency output X

C2.□	frequency output X	X stands for one of the connection terminals A, B or D.
		□ stands for A, B or D.
C2.□.1	pulse shape	Specify the pulse shape.
		Select:
		Symmetric (about 50% on and 50% off).
		Automatic (constant pulse width, at 100% pulse rate about 50% on and 50% off)
C2.□.2	pulse width	Fixed (fixed pulse rate, setting see Fct. C2.□.3 100% pulse rate)
		Only available if Fct. C2.□.1 is set to "Fixed".
		Range: 0.05...2000 ms
C2.□.3	100 % pulse rate	Note: max. setting value T_p [ms] \leq 500 / max. pulse rate [1/s], gives the pulse width = time where the output is activated.
		Pulse rate for 100% of the measuring range.
		Range: 0.0...10000 Hz
		Limitation 100% pulse rate \leq 100/s: $I_{max} \leq$ 100 mA
C2.□.4	measurement	Limitation 100% pulse rate $>$ 100/s: $I_{max} \leq$ 20 mA
		Measurements for activating the output.
		Select: volume flow / enthalpy flow / mass flow / specific enthalpy / density / flow speed / velocity of sound / gain / diagnostics 1, 2, 3

C2.□.5	range	0...100% of the measurement set in Fct. C2.□.4
		0...xx.xx _ _ _ (format and unit depend on the measurement, see above)
C2.□.6	polarity	Set polarity of frequency output, please note flow direction in C1.3.2!
		Select: both polarities (plus and minus values are displayed) / positive polarity (display for negative values = 0) / negative polarity (display for positive values = 0) / absolute value (use for the output)
C2.□.7	limitation	Set lower and upper limit for frequency output before applying the time constant.
		±xxx ... ±xxx%
		Range: -150...+150%
C2.□.8	low flow cutoff	Below set value, frequency output is set to zero.
		x.xxx ± x.xxx%
		Range: 0.0...20%
		1 st value = switching point / 2 nd value = hysteresis
		Condition: 2 nd value ≤ 1 st value
C2.□.9	time constant	Averages measurement
		Increasing value improves stability but delays the reaction.
		Range: 000.1...100 s
C2.□.10	invert signal	Define frequency output activation.
		Off (switch closed)
		On (switch open)
C2.□.11	phase shift w.r.t. B	Only available when configuring the A or D terminal and only if output B is a pulse or frequency output. If setting in Fct. C2.5.6 is "both polarities", the phase shift is prefixed by a symbol, e.g. -90° and +90°.
		Select: off (no phase shift) / 0° phase shift (between outputs A or D and B, inversion possible) / 90° phase shift (between outputs A or D and B, inversion possible) / 180° phase shift (between outputs A or D and B, inversion possible)
C2.□.12	information	1 st line: serial number of the I/O circuit board
		2 nd line: software version number
		3 rd line: production date of the circuit board
C2.□.13	simulation	Sequence see B1.□ frequency output X

pulse output X

C2.□	pulse output X	X stands for one of the connection terminals A, B or D.
		□ stands for A, B or D.
C2.□.1	pulse shape	Specify the pulse shape.
		Select: symmetric (about 50% on and 50% off) / automatic (constant pulse with about 50% on and 50% off at 100% pulse rate) / fixed (fixed pulse rate, setting see below Fct. C2.□.3 100% pulse rate)
C2.□.2	pulse width	Set time for pulse activation.
		Only available if Fct. C2.□.1 is set to "Fixed".
		Range: 0.05...2000 ms
		Note: max. setting value T_p [ms] ≤ 500 / max. pulse rate [1/s], gives the pulse width = time where the output is activated.

C2.□.3	max. pulse rate	Pulse rate for 100% of the measuring range.
		Range: 0.0...10000 Hz
		Limitation 100% pulse rate $\leq 100/s$: $I_{max} \leq 100$ mA
		Limitation 100% pulse rate $> 100/s$: $I_{max} \leq 20$ mA
C2.□.4	measurement	Measurements for activating the output.
		Select: volume flow / mass flow / enthalpy flow
C2.□.5	value p. pulse	Set value for volume, mass or enthalpy per pulse.
		xxx.xxx (format and unit depend on the measured variable)
		At max. pulse rate see above C2.□.3 pulse output.
C2.□.6	polarity	Set polarity, please note flow direction in C1.3.2!
		Select: both polarities (plus and minus values are displayed) / positive polarity (display for negative values = 0) / negative polarity (display for positive values = 0) / absolute value (use for the output)
C2.□.7	low flow cutoff	Below set value, pulse output is set to zero.
		x.xxx \pm x.xxx%
		Range: 0.0...20%
		1 st value = switching point / 2 nd value = hysteresis
		Condition: 2 nd value \leq 1 st value
C2.□.8	time constant	Averages measurement
		Increasing value improves stability but delays the reaction.
		Range: 000.1...100 s
C2.□.9	invert signal	Select:
		Off [activated output generates a high current at the output, switch closed]
		On [activated output generates a low current at the output, switch open]
C2.□.10	phase shift w.r.t. B	Only available when configuring the A or D terminal and only if output B is a pulse or frequency output. If setting in Fct. 2.5.6 is "both polarities", the phase shift is prefixed by a symbol, e.g. -90° and +90°.
		Select: off (no phase shift) / 0° phase shift (between outputs A or D and B, inversion possible) / 90° phase shift (between outputs A or D and B, inversion possible) / 180° phase shift (between outputs A or D and B, inversion possible)
C2.□.11	information	1 st line: serial number of the I/O circuit board
		2 nd line: software version number
		3 rd line: production date of the circuit board
C2.□.12	simulation	Simulation of pulse output.
		Sequence see B1.□ pulse output X

status output X

C2.□	status output X	X (Y) stands for one of the connection terminals A, B, C or D. □ stands for A, B, C or D.
C2.□.1	mode	The output shows the following measuring conditions: Out of specification (output activated, signals application error or error in device. Please refer to <i>Error messages</i> on page 93). Application error (output activated, signals application error or error in device. Please refer to <i>Error messages</i> on page 93). Polarity flow (polarity of the current flow) Over range flow (over range of the flow) Counter 1 or 2 preset (activates counter X when preset value is reached) Counter 3 preset (only available for special I/O) Output A, B, C or D (activated by the status of output Y, additional output data see below) Off (switched off) Error in device (when error, output activated)
C2.□.2	current output Y	Only appears if output A...C is set under "mode" (see above), and this output is a "current output". Polarity (is signaled) Over range (is signaled) Range change C
C2.□.2	frequency output Y and pulse output Y	Only appears if output A, B or D is set under "mode" (see above), and this output is a "frequency/pulse output". Polarity (is signaled) Over range (is signaled)
C2.□.2	status output Y	Only appears if output A...D is set under "mode" (see above), and this output is a "status output". Same signal (like other connected status output, signal can be inverted, see below)
C2.□.2	limit switch Y and control input Y	Only appears if output A...D / input A or B is set under "mode" (see above), and this output / input is a "limit switch / control input". Status off (is always selected here if status output X is connected with a limit switch / control input Y).
C2.□.2	off	Only appears if output A...D is set under "mode" (see above) and this output is switched off.
C2.□.3	invert signal	Off (activated output supplies a high current, switch closed) On (activated output supplies a low current, switch open)
C2.□.4	information	1 st line: serial number of the I/O circuit board 2 nd line: software version number 3 rd line: production date of the circuit board
C2.□.5	simulation	Sequence see B1.□ status output X

limit switch X

C2.□	limit switch X	X stands for one of the connection terminals A, B, C or D. □ stands for A, B, C or D.
C2.□.1	measurement	Measurements for activating the output. Select: volume flow / enthalpy flow / mass flow / specific enthalpy / density / flow speed / velocity of sound / gain / diagnostics 1, 2, 3
C2.□.2	threshold	Switching level, set threshold with hysteresis. xxx.x ±x.xxx (format and unit depend on the measurement, see above) 1 st value = threshold / 2 nd value = hysteresis Condition: 2 nd value ≤ 1 st value
C2.□.3	polarity	Set measured value polarity, please note flow direction in C1.3.2! Select: both polarities (plus and minus values are displayed) / positive polarity (display for negative values = 0) / negative polarity (display for positive values = 0) / absolute value (use for the output)
C2.□.4	time constant	Averages measurement Increasing value improves stability but delays the reaction. Range: 000.1...100 s
C2.□.5	invert signal	Define limit switch activation Off (activated output generates a high current, switch closed) On (activated output generates a low current, switch open)
C2.□.6	information	1 st line: serial number of the I/O circuit board 2 nd line: software version number 3 rd line: production date of the circuit board
C2.□.7	simulation	Sequence see B1.□ limit switch X

control input X

C2.□	control input X	X stands for connection terminal A or B. □ stands for A or B.
C2.□.1	mode	Off (control input switched off) Hold all outputs (hold current values, not display and counters) Output Y (hold current values) All outputs to zero (current values = 0%, not display and counters) Output Y to zero (current value = 0%) All counters (reset all counters to "0") Counter "Z" reset (set counter 1, 2 or 3 to "0") Stop all counters Stop counter "Z" (stops counter 1, 2 or 3) Zero outp.+stop Cnt. (all outputs 0%, stop all counters, not the display) External range Y (control input for external range of current output Y) - also make this setting on current output Y (no check if current output Y is available) Error reset (all resettable errors are deleted)
C2.□.2	invert signal	Select: off / on

C2.□.3	information	1 st line: serial number of the I/O circuit board
		2 nd line: software version number
		3 rd line: production date of the circuit board
C2.□.4	simulation	Sequence see B 1.□ control input X

C3 I/O counter

C3.1	counter 1	Set function of counter □ □ stands for 1, 2, 3
C3.2	counter 2	
C3.3	counter 3	
C3.□.1	funct. of counter	Define counter
		Select:
		Sum counter (counts positive and negative values)
		+counter (counts only the positive values)
		-counter (counts only the negative values)
		Off (counter is switched off)
C3.□.2	measurement	Selection of the measurement for counter □
		Select: volume flow / mass flow / enthalpy flow
C3.□.3	low flow cutoff	Sets output value to "0".
		Range: 0.0...20%
		1 st value = switching point / 2 nd value = hysteresis
		Condition: 2 nd value ≤ 1 st value
C3.□.4	time constant	Averages measurement
		Increasing value improves stability but delays the reaction.
		Range: 000.0...100.0 s
C3.□.5	preset value	If this value is reached, positive or negative, a signal is generated that can be used for a status output at which "preset counter X" has to be set.
		Preset value (max. 8 digits) x.xxxxx in selected unit, see C5.7.9 + 12
C3.□.6	reset counter	Sequence see Fct. A3.2, A3.3 and A3.4
C3.□.7	set counter	Set counter □ to the desired value.
		Select: break (exit function) / set value (opens the editor to make the entry)
		Query: set counter?
		Select: no (exit function without setting the value) / yes (sets the counter and exits the function)
C3.□.8	stop counter	Counter □ stops and holds the current value.
		Select: no (exits the function without stopping the counter) / yes (stops the counter and exits the function)
C3.□.9	start counter	Start counter
		Select: no (exits the function without starting the counter) / yes (starts the counter and exits the function)
C3.□.10	information	1 st line: serial number of the I/O circuit board
		2 nd line: software version number
		3 rd line: production date of the circuit board

C4 I/O HART

C4	I/O HART	Selection / display of the 4 dynamic variables (DV) for HART®.
		The HART® current output (terminal A basic I/Os or terminal C modular I/Os) always has a fixed link to the primary variables (PV). Fixed links of the other dynamic variables (1-3) are only possible if additional analog outputs (current and frequency) are available; if not, the measurement can be freely selected from the following list: in Fct. A4.1 "measurement".
		<input type="checkbox"/> stands for 1, 2, 3 or 4
		X stands for connection terminals A...D.
C4.1	PV is	Current output (primary variable)
C4.2	SV is	(secondary variable)
C4.3	TV is	(third variable)
C4.4	4V is	(fourth variable)
C4.5	HART units	Unit change of DVs (dynamic variables) in the display; usually varied.
		Break: return with 8 key
		HART display®: copies the settings for the units to the settings for DVs Standard: factory settings for DVs
C4. <input type="checkbox"/> .1	current output X	Shows the current analog measured value of the linked current output. The value can not be changed!
C4. <input type="checkbox"/> .1	frequency output X	Shows the current analog measured value of the linked frequency output, if present. The value can not be changed!
C4. <input type="checkbox"/> .1	HART dynamic var.	Measurements of the dynamic variables for HART®.
		Linear measurements: volume flow / enthalpy flow / mass flow / specific enthalpy / density / flow speed / velocity of sound / gain / diagnostics 1, 2, 3 / counter 1, 2, 3 / operating hours
		Digital measurements: counter 1, 2, 3 / operating hours

C5 device

C5.1	device info	
C5.1.1	tag	Settable characters (max. 8 digits): A...Z; a...z; 0...9; / - , .
C5.1.2	C number	CG number, non-alterable (input/output versions)
C5.1.3	device serial no.	Serial no. of the system.
C5.1.4	electronic serial no.	Serial no. of the electronic assembly, can not be changed.
C5.1.5	SW.REV.MS	1 st line: serial number of the I/O circuit board
		2 nd line: software version number
		3 rd line: production date of the circuit board
C5.1.6	Electronic Revision ER	1 st line: serial number of the I/O circuit board
		2 nd line: software version number
		3 rd line: production date of the circuit board
C5.2	display	
C5.2.1	language	Select: English / Français / Deutsch
C5.2.2	contrast	Adjust display contrast for extreme temperatures.
		Setting: -9...+9 Change is immediate!

C5.2.3	default display	Specification of the default display page that is returned to after a short delay period.
		Select: none (the current page is always active) / 1. meas. page (show this page) / 2. meas. page (show this page) / status page (show only status messages) / graphic page (trend display of the 1 st measurement)
C5.2.5	SW.REV.UIS	Software Revision User Interface Software
		1 st line: serial number of the I/O circuit board
		2 nd line: software version number
		3 rd line: production date of the circuit board
C5.3	1. meas. page	□ stands for: 3 = meas. page 1
C5.4	2. meas. page	4 = meas. page 2
C5.□.1	function	Specify number of measured value lines (font size).
		Select: one line / two lines / three lines
C5.□.2	measurement 1.line	Specify measurement for 1 st line.
		Select: volume flow / enthalpy flow / mass flow / specific enthalpy / density / flow speed / velocity of sound / gain / diagnostics 1, 2, 3
C5.□.3	range	0...100% of the measurement set in Fct. C5.□.2.
		0...xx.xx _ _ _ (format and unit depend on the measurement)
C5.□.4	limitation	Set lower and upper limit for frequency output before applying the time constant.
		xxx%
		Range: -120...+120%
C5.□.5	low flow cutoff	Sets output to "0".
		x.xxx ± x.xxx %
		Range: 0.0...20%
		1 st value = switching point / 2 nd value = hysteresis
		Condition: 2 nd value ≤ 1 st value
C5.□.6	time constant	Averages measurement
		Increasing value improves stability but delays the reaction.
		Range: 0.1...100 s
C5.□.7	format 1.line	Specify decimal places.
		Select: automatic (adaptation carried out automatically) / X (= none) ...X.XXXXXXXXXX (max. 8 digits)
C5.□.8	measurement 2.line	Specify measurement 2 nd line (only available if this 2 nd line is activated)
		Select: volume flow / enthalpy flow / mass flow / specific enthalpy / density / flow speed / velocity of sound / gain / diagnostics 1, 2, 3 / counter 1, 2, 3 / bargraph / operating hours
C5.□.9	format 2.line	Specify decimal places.
		Select: automatic (adaptation carried out automatically) / X (= none) ...X.XXXXXXXXXX (max. 8 digits)
C5.□.10	measurement 3.line	Specify measurement 3 rd line (only available if this 3 rd line is activated)
		Select: volume flow / enthalpy flow / mass flow / specific enthalpy / density / flow speed / velocity of sound / gain / diagnostics 1, 2, 3 / counter 1, 2, 3 / operating hours

C5.□.11	format 3.line	Specify decimal places.
		Select: automatic (adaptation carried out automatically) / X (= none) ...X.XXXXXXXXX (max. 8 digits)
C5.5	graphic page	
C5.5.1	select range	Graphic page always shows trend curve of the measurement of the 1 st page / 1 st line, see Fct. C5.3.2.
		Select: manual (set range in Fct. C5.5.2)
		Automatic (automatic depiction based on the measured values)
		Reset only after parameter change or after switching off and on.
C5.5.2	range	Set the scaling for the Y axis.
		Only available if "manual" is set in C5.5.1.
		+xxx ±xxx%
		Range: -100...+100%
		1 st value = lower limit / 2 nd value = upper limit
Condition: 1 st value ≤ 2 nd value		
C5.5.3	time scale	Set the time scaling for the X axis, trend curve.
		xxx min
		Range: 0...100 min
C5.6	special functions	
C5.6.1	reset errors	Reset?
		Select: no/yes
C5.6.2	save settings	Save current settings.
		Select: cancel (exit function without saving) / backup 1 (save in storage location 1) / backup 2 (save in storage location 2)
		Query: go on with copy? (can not be undone).
		Select: no (exit function without saving) / yes (copy current settings to storage backup 1 or backup 2)
C5.6.3	load settings	Load saved settings.
		Select: cancel (exit function without loading) / factory settings (load in state as delivered) / backup 1 (load data from storage location 1) / backup 2 (load data from storage location 2) / load sensor data (factory settings of calibration data)
		Query: go on with copy? (can not be undone)
		Select: no (exit the function without saving) / yes (load data from the selected storage location)
C5.6.4	password quick set	Password required to change data in the quick setup menu.
		xxxx (password required)
		Range 4 digits: 0001...9999
		0000 (= to quick setup menu without password)
C5.6.5	password setup	Password required to change data in the setup menu.
		0000 (= to quick setup menu without password)
		xxxx (password required); range 4 digits: 0001...9999

C5.6.6	GDC IR interface	This function requires an optical GDC adapter connected to the LCD display.
		Break (exit function without connection)
		Activate (Interrupts the optical keys)
		After 60 seconds pass without a connection being established or after the adapter is removed, the function is exited and the optical keys are active again.
C5.7	units	
C5.7.1	size	mm; inch
C5.7.2	volume flow	m ³ /d; m ³ /h; m ³ /min; m ³ /s; l/h; l/min; l/s (l = litres); ext. unit selection (activates option for more units, sequence see below); cf/d; cf/h; cf/m; cf/s
C5.7.3	ext. unit selection	Active if "ext. unit selection" is selected in C5.7.2.
		MMcf/d; Mcf/d; MMcf/h; Mcf/h; free unit (set factor and text in the next two functions, sequence see below)
C5.7.4	text free unit	Active if "free unit" is selected in C5.7.3.
		For text to be specified refer to <i>Set free units</i> on page 85.
C5.7.5	[m ³ /s]*factor	Specification of the conversion factor, based on m ³ /s.
		For information refer to <i>Set free units</i> on page 85.
C5.7.6	enthalpy flow	Steam flow option
		MW; GW; kBTU/s; free unit (set factor and text in the next two functions, sequence see below)
C5.7.6	corr. volume flow	Gas flow option
		MMscf/d; Mscf/d; MMscf/h; Mscf/h; scf/d; scf/h; scf/m; scf/s; Nm ³ /d; Nm ³ /h; free unit (set factor and text in the next two functions, sequence see below)
C5.7.7	text free unit	Active if "free unit" is selected in C5.7.6.
		For text to be specified refer to <i>Set free units</i> on page 85.
C5.7.8	[Normal m ³ /s]*factor	Gas flow option
		Specification of the conversion factor, based on normal m ³ /s.
		For information refer to <i>Set free units</i> on page 85.
C5.7.8	[W]*factor	Steam flow option
		Specification of the conversion factor, based on W.
		For information refer to <i>Set free units</i> on page 85.
C5.7.9	mass flow	lb/h; lb/s; t/h; kg/h; kg/s; free unit (set factor and text in the next two functions, sequence see below)
C5.7.10	text free unit	Active if "free unit" is selected in C5.7.9.
		For text to be specified refer to <i>Set free units</i> on page 85.
C5.7.11	[kg/s]*factor	Specification of the conversion factor, based on kg/s.
		For information refer to <i>Set free units</i> on page 85.
C5.7.12	specific enthalpy	Steam flow option
		kJ/kg; free unit
C5.7.13	text free unit	Steam flow option
		Active if "free unit" is selected in C5.7.12.
		For text to be specified refer to <i>Set free units</i> on page 85.

C5.7.14	[J/kg]*factor	Steam flow option
		Specification of the conversion factor. based on J/kg.
		For information refer to <i>Set free units</i> on page 85.
C5.7.15	velocity	m/s; ft/s
C5.7.16	volume	Cf; m ³ ; L; ext. unit selection (activates option for more units, sequence see below)
C5.7.17	ext. unit selection	Active if "ext. unit selection" is selected in C5.7.16.
		MMcf; Mcf; free unit (set factor and text in the next two functions, sequence see below)
C5.7.18	text free unit	Active if "free unit" is selected in C5.7.17.
		For text to be specified refer to <i>Set free units</i> on page 85.
C5.7.19	[m ³]*factor	Specification of the conversion factor, based on m ³ .
		For information refer to <i>Set free units</i> on page 85.
C5.7.20	corrected volume	Gas flow option
		MMscf; Mscf; scf; Nm ³ ; free unit (set factor and text in the next two functions, sequence see below)
C5.7.20	enthalpy	Steam flow option
		MJ; GJ; kBTU; free unit (set factor and text in the next two functions, sequence see below)
C5.7.21	text free unit	Active if "free unit" is selected in C5.7.20.
		For text to be specified refer to <i>Set free units</i> on page 85.
C5.7.22	[Normal m ³]*factor	Gas flow option
		Specification of the conversion factor, based on normal m ³ .
		For information refer to <i>Set free units</i> on page 85.
C5.7.22	[J]*factor	Steam flow option
		Specification of the conversion factor, based on J.
		For information refer to <i>Set free units</i> on page 85.
C5.7.23	mass	Lb; t; kg; free unit (set factor and text in the next two functions, sequence see below)
C5.7.24	text free unit	Active if "free unit" is selected in C5.7.23.
		For text to be specified refer to <i>Set free units</i> on page 85.
C5.7.25	[kg]*factor	Specification of the conversion factor, based on kg.
		For information refer to <i>Set free units</i> on page 85.
C5.7.26	density	Lb/cf; kg/m ³ ; kg/l; free unit (set factor and text in the next two functions, sequence see below)
		Active if "free unit" is selected in C5.7.26.
C5.7.27	text free unit	Active if "free unit" is selected in C5.7.26.
		For text to be specified refer to <i>Set free units</i> on page 85.
C5.7.28	[kg/m ³]*factor	Specification of the conversion factor, based on kg/m ³ .
		For information refer to <i>Set free units</i> on page 85.
C5.7.29	pressure	Bar; kPa; Pa; psi
C5.7.30	temperature	°C; K; °F
C5.8	HART	
C5.8.1	HART	Switch HART® communication on/off.
		Select:
		HART® on current = 4...20 mA / HART® off current = 0...20 mA

C5.8.2	address	Set address for HART® operation.
		Select: 00 (point-to-point operation, current output has normal function, current = 4...20 mA) / 01...15 (multidrop operation, current output has a constant setting of 4 mA)
C5.8.3	message	Set required text:
		A...Z ; a...z ; 0...9 ; / - + , *
C5.8.4	description	Set required text:
		A...Z ; a...z ; 0...9 ; / - + , *
C5.9	quick setup	Activate quick access in quick setup menu
		Select: yes (switched on) / no (switched off)
C5.9.1	reset counter 1, 2, 3	Reset counter 1, 2 or 3 in quick setup menu?
		Select: yes (activated) / no (switched off)

6.3.4 Set free units

Free units	Sequences to set texts and factors
Texts	
Volume flow, mass flow and density:	3 digits before and after the slash xxx/xxx (max. 3 digits before / after the slash)
Volume, mass:	xxx (max. 3 digits)
Permissible characters:	A...Z ; a...z ; 0...9 ; / - + , . * ; @ \$ % ~ () [] _
Conversion factors	
Desired unit	= [unit see above] * conversion factor
Conversion factor	Max. 9 digits
Shift decimal point:	↑ to the left and ↓ to the right

6.4 Setup of flow measurement

Steam flow measurement with the OPTISONIC 8300 can be configured in two ways:

Volume flow measurement

For this configuration the GFC 300 must have the default gas flow measurement option. Mass flow calculation is done by an external system, for example a flow computer or a DCS.

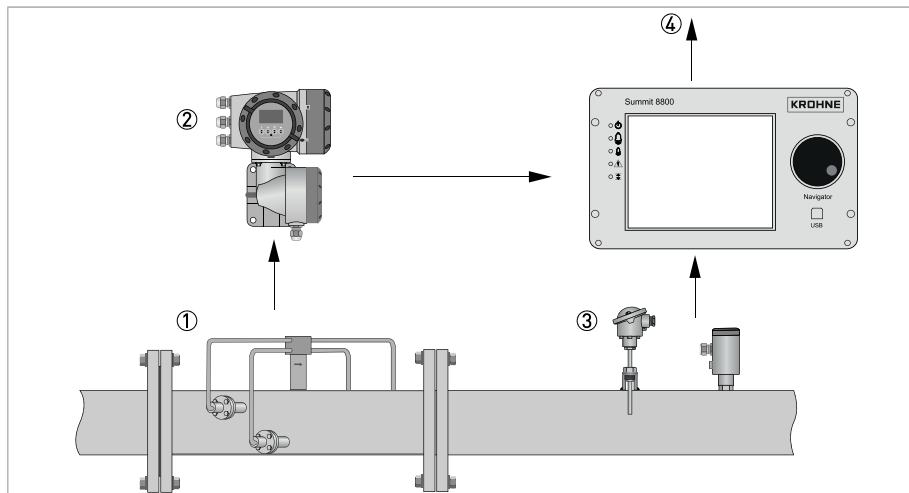

Figure 6-7: Steam flow measurement with flow converter with gas flow option

- ① Flow sensor provides volume flow information.
- ② Flow converter with gas flow option.
- ③ Pressure and temperature transmitters.
- ④ Flow computer (optional) calculates volumetric flow, mass flow and energy flow.



INFORMATION!

For this configuration, function number 1 must be set up, function number 2 is optional. Other functions as described in this paragraph, can not be used.

Steam mass flow measurement

For this configuration, the GFC 300 must have the steam flow measurement option. This is indicated on the converter type plate.

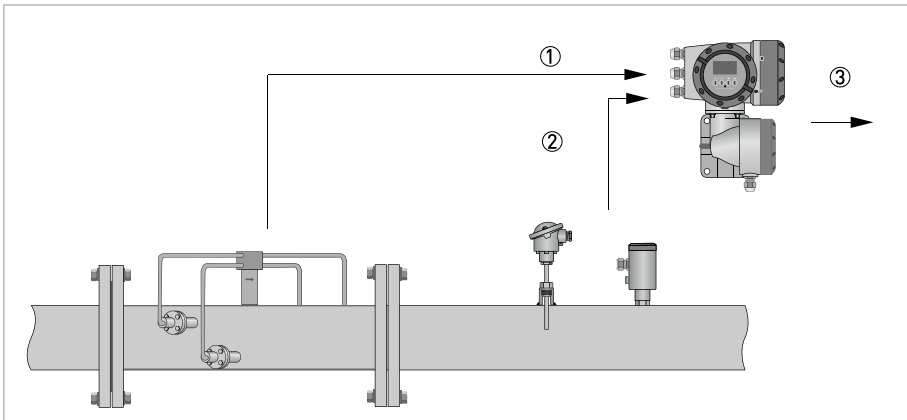

Figure 6-8: Steam flow measurement with flow converter with steam option

- ① Flow sensor provides volume flow information.
- ② Pressure and temperature transmitters provides information to flow converter.
- ③ Flow converter with steam flow option calculates volumetric flow, mass flow and energy flow.

Functional diagram of GFC 300 with steam option

Flow speed		→	Volume flow calculation and correction (Reynolds linearization)	→	Mass flow and energy calculation	→	Volume Flow		
Temperature	Corrected diameter = $f(T, p)$	→		Viscosity = $f(T)$		→	Density = $f(T, p)$	→	Energy Flow
	Spec. enthalpy = $f(T, p)$	→				→		Mass Flow	
VOS	VOS monitor					→	VOS alarm		

**INFORMATION!**

Function number 1, 3 and 4 must be set up. Function number 5 and 6 may be used optionally.

Overview of functions

Function number	Description	Needed input and settings	Remarks
1	Volume flow measurement using flow speed, tube inner diameter and calibration settings	K-factor and other calibration data	Setting provided from factory calibration.
2	Correction of tube inner diameter based on static temperature and pressure input	Temperature and pressure setting for calibration and operation.	set-up ex-factory.
		Temperature and pressure expansion factors of pipe material	set-up ex-factory.
3	Correction of tube inner diameter based on measured temperature and pressure input	Temperature and pressure setting for calibration.	set-up ex-factory.
		Temperature and pressure expansion factors of pipe material	set-up ex-factory.
		Temperature and pressure measurement during operation.	
4	Calculation of steam density and mass flow	Temperature and pressure measurement during operation.	Ranges can be set-up ex-factory if transmitters are used from factory.
		Set-up of range of temperature and pressure measurements.	
5	Mass flow with Reynolds linearization	Temperature and pressure measurement during operation.	When the calibration is performed by the factory, the linearization table is set-up ex-factory when applicable.
		Set-up of range of temperature and pressure measurements.	
6	Velocity of Sound (VoS) monitor. Monitoring of deviation between measured and calculated VoS.	Setup of alarm parameters, eg maximum deviation and delay time.	
		Temperature measurement during operation.	
		Set-up of range of temperature measurement.	

6.4.1 Function 1: Volume flow calculation

The volume flow will be calculated based on the measured flow velocity and the inner diameter of the pipe. The inner diameter of the flowmeter will be programmed in the converter at the factory.

As a result of the gas calibration a GK factor will be determined, which will be programmed in the converter (menu C1.2.2).

6.4.2 Function 2: Correction of inner diameter based on static temperature and pressure input

Expansion of the pipe can be caused by changes in temperature and pressure. If the inner pipe diameter is different than what is was during calibration, deviations can occur. A function to correct this is available in the converter.

For temperature, the used correction method is $MF_{T2} = MF_{T1} \times (1 + 3\alpha\Delta T)$ in which:

α = thermal expansion factor

ΔT = temperature difference between calibration and operation.

For pressure, the used correction method is $MF_{P2} = MF_{P1} \times (1 + 3\alpha\Delta P)$ in which:

α = pressure expansion factor

ΔT = pressure difference between calibration and operation.

Temperature and pressure expansion factors of the pipe material are set-up at the factory. The next settings are needed:

Menu	Function	Setting
C1.11	P&T correction	P&T correction normal
C1.12	P&T inputs	Fixed
C1.13	Temperature	Enter a fixed setting of the average actual steam temperature
C1.14	Pressure	Enter a fixed setting of the average actual absolute pressure

6.4.3 Function 3: Correction of inner diameter based on measured temperature and pressure



INFORMATION!

This function can only be used with the steam flow option.

This function works in the same way as described in the previous section, but instead of the fixed values the temperature and pressure are measured.

In menu C2.□.1 to C2.□.7 the temperature and pressure inputs are set-up.

6.4.4 Function 4: Calculation of steam density and mass flow

**INFORMATION!**

This function can only be used with the steam flow option.

Using the measured values for volume flow, temperature and pressure, the massflow and enthalpy of the steamflow is calculated. This is done according to IAPWS-IF97 (International Association for the Properties of Water and Steam).

No additional settings are required to calculate the mass flow and enthalpy. If specific units are required for massflow and energy, then they can be setup in menu 5.7.

6.4.5 Function 5: Reynolds linearisation

For optimal accuracy the volume flow measurement result can be linearised, as any deviation depends on a specific Reynolds number. The actual Reynolds correction curve(s) are set-up in the factory based on the calibration results.

In case of a converter with gas flow option, the Reynolds linearisation must be done in an external system, for instance a flow computer.

In case of a converter with steam flow option, the Reynolds linearisation can be done in the converter.

The linearisation curve is activated in menu option C1.9.1.

The linearisation correction factors are set-up at the factory.

6.4.6 Function 6: Velocity of Sound monitoring



INFORMATION!

This function is only available with the steam flow option.

At a steam flow measurement the Velocity Of Sound (VOS) can be calculated using the input of the temperature and the pressure. As a diagnostic function, the measured VOS can be compared against the calculated VOS.

The diagnostic function can be setup in menu C1.7 and C1.8.

Menu	Setting
C1.7	Monitor function on/off
C1.8.1	Matching factor (read only, expected ratio measured / calculated VOS)
C1.8.2	Actual ratio measured / calculated VOS (read only)
C1.8.3	Matching factor (setting of expected ratio measured / calculated VOS)
C1.8.4	VOS tolerance, setting of absolute max. allowed difference between expected and calculated VOS
C1.8.5	Time constant, maximum time that the max. allowed difference between expected and calculated VOS can be exceeded before an alarm is generated.

6.5 Description of functions

6.5.1 Reset counter in the menu "quick setup"



INFORMATION!

It may be necessary to activate resetting of the counter in the menu "quick setup".

Key	Display	Description and setting
▶	quick setup	Press and hold for 2.5 s, then release the key.
▶	language	-
2 x ▼	reset	-
▶	reset errors	-
▼	counter 1	Select desired counter.
▼	counter 2	
▼	counter 3	
▶	reset counter no	-
▼ or ▲	reset counter yes	-
←	counter 1,2, 3	Counter has been reset.
3 x ←	Measuring mode	-

6.5.2 Deleting error messages in the menu "quick setup"

Key	Display	Description and setting
▶	quick setup	Press and hold for 2.5 s, then release the key.
▶	language	-
2 x ▼	reset	-
▶	reset errors	-
▶	reset? no	-
▲ or ▼	reset? yes	-
←	reset errors	Error has been reset.
3 x ←	measuring mode	-

6.6 Error messages

Error code	Group message	Description	Error handling
F (bold)	error in device	No measurement possible, measured values are not valid.	Repair or replace device and/or CPU. Contact manufacturer service center.
F	application error	No measurement possible, but device ok.	Check parameter settings / power off - wait 5 seconds - power on device.
S	out of specification	Unreliable measurement.	Maintenance required, check flow profile.
C	check in progress	Test function is active, device is stand-by.	Wait until finished.
I	information	No direct impact on measurements.	No action needed.

Error code	Error message	Description	Error handling
F (bold)	error in device	No measurement possible, measured values are not valid.	Repair or replace device and/or CPU; contact manufacturer service center.
F (bold)	IO 1 (or IO 2)	Error or failure of IO Module 1 (or 2).	Try to load settings (menu C5.6.3). If error does not disappear, replace electronics unit.
F (bold)	parameter	Error or failure of data manager, parameter or hardware error.	Try to load settings (menu C5.6.3). If error does not disappear, replace electronics unit.
F (bold)	configuration	Incorrect configuration or no confirmation.	Confirm change of module. If configuration is unchanged, replace electronics unit.
F (bold)	display	Error or failure of display unit, parameter or hardware error.	Defect; replace electronics units.
F (bold)	current in/output A/B	Error or failure of the current input or output A or B, parameter or hardware error.	Defect; replace electronics units.
F (bold)	current output C	Error or failure of the current output C, parameter or hardware error.	Defect; replace electronics units.
F (bold)	software user interface	Error in software operation detected.	Defect; replace electronics units.
F (bold)	hardware settings	Detected hardware and set hardware settings do not match.	Follow display instructions.
F (bold)	hardware detection	Hardware can not be detected.	Defect; replace electronics units.
F (bold)	RAM/ROM error IO 1 (or IO 2)	RAM or ROM error detected	Defect; replace electronics units.
F (bold)	fieldbus	Malfunction of the fieldbus interface profibus or FF or Modbus / Ethernet interface.	Contact manufacturer service center.
F (bold)	communication dsp-up	Error in or failure of the communication between the processors, parameter or hardware error.	Defect; replace electronics unit.
F (bold)	sensor driver	Sensor driver is malfunctioning.	Replace electronics units.
F (bold)	uProc.	Microcontroller is malfunctioning.	Replace electronics units.
F (bold)	dsp	DSP is malfunctioning.	Replace electronics units.
F (bold)	parameter frontend	Invalid parameter or combination of parameters at the frontend.	Defect; replace electronics units.

Error code	Error message	Description	Error handling
F	application error	Application-dependent error of the complete device, device is however ok.	
F	open circuit A (or B, C)	Current on current output A (or B, C) too low.	Check cable or reduce resistance (< 1000 Ohm).
F	over range A (or B, C)	Current on current output A (or B, C) is limited by parameter setting.	Extend upper or lower limit for current output in menu C2.□.8.
F	over range A (or B, D)	Pulse on frequency output A (or B, D) is limited by parameter setting.	Extend upper or lower limit for frequency output in menu C2.□.7.
F	active settings	Error during CRC check (Cyclic Redundancy Check) of the active settings.	Load settings; factory setting, back up 1 or back up 2.
F	factory settings	Error during CRC check of factory settings.	
F	back up 1 (or 2) settings	Error during CRC check of back up 1 (or 2) settings.	Save active settings in back up 1 or back up 2.
F	wiring A (or B)	Current of current input is below 0.5 mA or above 23 mA. Open or short circuit of control input A (or B).	Check connection of control input or current input.
F	flow exceeding limit	Over range, the measured values are limited by the filter setting.	Limitation fct. C1.3.1, increase values.
F	signal lost path 1 (or 2, 3)	Signal lost on path 1 (or 2,3).	Check vacuum, composition of gas or collection of liquid in transducer tubes.
F	transducer delay	Invalid on-line measurement of the transducer delay.	
F	temperature input	No temperature data available.	
F	pressure input	No pressure data available.	
F	P & T input	Pressure and/or temperature out of range.	
F	VoS monitor	Invalid VoS values due to error in measurement of temperature, pressure or flow.	
S	out of specification	Unreliable measurement.	Maintenance required, check flow profile.
S	overflow counter 1 (or 2, 3)	Counter is overflowing and will start again at zero.	No action needed.
S	backplane invalid	Error during CRC check of backplane.	Restore data records on backplane.
S	error current A (or B)	Error current at current input A (or B).	
S	unreliable 1 (or 2 or 3)	Signal detection of path 1 (or 2 or 3) is difficult due to excessive noise or variations in the amplitude of the received signal. The accuracy is not guaranteed.	
S	frontend calibration	Invalid calibration data of the frontend.	
S	dsp timing error	Ping time of the frontend is too short.	

Error code	Error message	Description	Error handling
C	checks in progress	Test run of the device, measured value can be set to simulated measured values or to a fixed value.	
C	simulation flow	Sensor electronics simulates measurement of volume flow.	
C	simulation VoS	Sensor electronics simulates measurement of velocity of sound.	
C	simulation fieldbus	Simulation is active on the fieldbus values.	
I	counter 1 (or 2, 3) stopped	Counter has stopped.	Reset counter in menu C5.9.1 (or C5.9.2, C5.9.3).
I	power fail	The device was not in operation for an unknown period of time.	Temporary power failure, counters did not run during the failure.
I	control input A (or B) active	Information only.	No action needed.
I	over range display 1 (or 2)	1 st row on 1 st (or 2 nd) measurement page is limited by parameter setting.	Extend upper or lower limit for limitation in menu C5.3.4 (or C5.4.4).
I	backplane sensor	Incompatible data sensor on backplane.	
I	backplane settings	Incompatible data on backplane.	
I	backplane difference	Different data on backplane and display.	
I	optical interface	GDC IR interface is operational, local display can not be used.	The keys are ready for operation again 60 seconds after the end of data transfer / removal of GDC IR interface.
I	write cycles overfl.	The maximum number of write cycles of the EEPROM or FRAMS on the Profibus PCB has been exceeded.	
I	baudrate search	Searching for the baudrate of the Profibus DP interface.	
I	no data exchange	No data exchange between converter and Profibus.	
I	start up	The converter is starting up and wait time is required.	

7.1 Spare parts availability

The manufacturer adheres to the basic principle that functionally adequate spare parts for each device or each important accessory part will be kept available for a period of 3 years after delivery of the last production run for the device.

This regulation only applies to spare parts which are subject to wear and tear under normal operating conditions.

7.2 Availability of services

The manufacturer offers a range of services to support the customer after expiration of the warranty. These include repair, maintenance, technical support and training.



INFORMATION!

For more precise information, please contact your local sales office.

7.3 Returning the device to the manufacturer

7.3.1 General information

This device has been carefully manufactured and tested. If installed and operated in accordance with these operating instructions, it will rarely present any problems.



CAUTION!

Should you nevertheless need to return a device for inspection or repair, please pay strict attention to the following points:

- *Due to statutory regulations on environmental protection and safeguarding the health and safety of the personnel, the manufacturer may only handle, test and repair returned devices that have been in contact with products without risk to personnel and environment.*
- *This means that the manufacturer can only service this device if it is accompanied by the following certificate (see next section) confirming that the device is safe to handle.*



CAUTION!

If the device has been operated with toxic, caustic, flammable or water-endangering products, you are kindly requested:

- *to check and ensure, if necessary by rinsing or neutralising, that all cavities are free from such dangerous substances,*
- *to enclose a certificate with the device confirming that it is safe to handle and stating the product used.*

7.3.2 Form (for copying) to accompany a returned device

Company:		Address:	
Department:		Name:	
Tel. no.:		Fax no.:	
Manufacturer's order no. or serial no.:			
The device has been operated with the following medium:			
This medium is:	radioactive		
	water-hazardous		
	toxic		
	caustic		
	flammable		
	We checked that all cavities in the device are free from such substances.		
	We have flushed out and neutralized all cavities in the device.		
We hereby confirm that there is no risk to persons or the environment through any residual media contained in the device when it is returned.			
Date:		Signature:	
Stamp:			

7.4 Disposal



CAUTION!

Disposal must be carried out in accordance with legislation applicable in your country.

8.1 Measuring principle

- Like canoes crossing a river, acoustic signals are transmitted and received along a diagonal measuring path.
- A sound wave going downstream with the flow travels faster than a sound wave going upstream against the flow.
- The difference in transit time is directly proportional to the mean flow velocity of the medium.

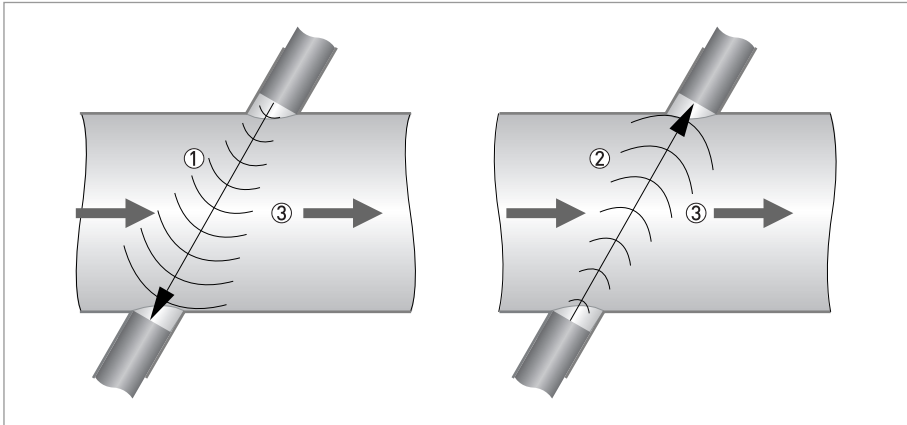

Figure 8-1: Measuring principle

- ① Sound wave against flow direction
- ② Sound wave with flow direction
- ③ Flow direction

8.2 Technical data



INFORMATION!

- The following data is provided for general applications. If you require data that is more relevant to your specific application, please contact us or your local sales office.
- Additional information (certificates, special tools, software,...) and complete product documentation can be downloaded free of charge from the website (Download Center).

Measuring system

Measuring principle	Ultrasonic transit time
Application range	Flow measurement of super heated steam and other high temperature gasses
Measured value	
Primary measured value	Transit time
Secondary measured values	Volume flow, enthalpy flow, mass flow, flow speed, flow direction, speed of sound, gain, signal to noise ratio, reliability of flow measurement, quality of acoustic signal

Design

Features	1 or 2 path flow sensor with high temperature transducers.
Modular construction	The measurement system consists of a measuring sensor and a signal converter.
Remote version	In field (F) mount version: OPTISONIC 8000 with GFC 300 F signal converter
Nominal diameter	DN100...600 / 4...24"
Measurement range	-60...60 m/s / -197...197 ft/s
Input / output options	
Inputs / outputs	Current (incl. HART®), pulse, frequency and/or status output, limit switch and/or control input (depending on the I/O version)
Counters	2 internal counters with a max. of 8 counter places (e.g. for counting volume and/or mass units).
Self diagnostics	Integrated verification, diagnosis functions, flowmeter, process, measured value, bargraph
Communication interfaces	Modbus, HART®, FF
Display and user interface	
Graphic display	LC display, backlit white
	Size: 128x64 pixels, corresponds to 59x31 mm = 2.32"x1.22"
	Display turnable in 90° steps.
	The readability of the display could be reduced at ambient temperatures below -25°C / -13°F.
Operator input elements	4 optical keys for operator control of the signal converter without opening the housing.
	Option: Infrared interface (GDC)
Remote control	PACTware® including Device Type Manager (DTM)
	All DTM's and drivers are available at the internet homepage of the manufacturer.

Display functions	
Menu	Programming of parameters at 2 measured value pages, 1 status page, 1 graphic page (measured values and descriptions adjustable as required).
Language of display texts	English, French, German
Units	Metric, British and US units selectable from list / free unit.

Measuring accuracy

Volume flow	
Reference conditions for calibration	Medium: air
	Temperature: 20°C / 68°F
	Pressure: 1 bar / 14.5 psi
Air calibration (standard)	DN100 / 4": < ± 1.5% of actual measured flow rate
	DN150...600 / 6...24": < ± 1% of actual measured flow rate
Repeatability	< ± 0.2%
Mass flow	
Reference conditions for calibration	Medium: Pressurised Natural Gas
	Temperature: depending on calibration
	Pressure: depending on calibration
Pressurised natural gas calibration (optional)	Calculations and correction in GFC 300 converter or Summit flow computer.
	DN100 / 4": ≤ ± 1.5% of actual measured mass flow.
	DN150...600 / 6...24": ≤ ± 1% of actual measured mass flow.
Repeatability	< ± 0.2%

Operating conditions

Temperature	
Process temperature	Standard version: -25...+540°C / -13...+1004°F
	Higher temperatures on request.
Ambient temperature	Sensor: -40...+70°C / -40...+158°F
	Signal converter: -40...+65°C / -40...+149°F
Storage temperature	-50...+70°C / -58...+158°F
Pressure	
Flanged	According to flange standard, maximum pressure limited by transducer material:
	SS347: 10 MPa at 540°C
	INCONEL® Alloy 625: 20 MPa at 540°C
Flangeless (weld in) connection	Acc. to design pressure
Properties of medium	
Physical condition	Super heated steam (>15°C superheat), high temperature gas
Density	Standard: 0.6...50 kg/m ³ (> 15°C superheat)
Velocity of sound	450...750 m/s

Installation conditions

Installation	For detailed information see chapter "Installation".
Inlet run	≥ 20 DN
Outlet run	≥ 3 DN
Dimensions and weights	For detailed information see chapter "Dimensions and weights".

Materials

Sensor	
Flanges	Standard: carbon steel ASTM A105 N
	Optional: high temperature steel like for example P-11, P-22
Tube	Standard: carbon steel ASTM A106 Gr. B or equivalent (For flangeless design: according to pipe specification)
	Optional: high temperature steel like for example P-11, P-22
	Carbon steel compatible with tube material
Transducer nozzles	Carbon steel compatible with tube material
Transducers	Standard: stainless steel 347 (UNS S34700, W. nr.:1.4550)
	High pressure: INCONEL® Alloy 625 (UNS N06625, W. nr.:2.4856)
Tube transducer cabling	Stainless steel 316 L (1.4401)
Connection box	Die-cast aluminium; polyurethane coated
Converter housing	
Field version	Standard: die-cast aluminium, polyurethane coated
	Option: stainless steel 316 L (1.4408)

Electrical connections

Power supply	Standard
	100...230 VAC (-15% / +10%), 50/60 Hz
	Option
	24 VDC (-55% / +30%) 24 VAC/DC (AC: -15% / +10%; DC: -25% / +30%)
Power consumption	AC: 22 VA
	DC: 12 W
Signal cable	MR02 (shielded cable with 2 triax cores): Ø 10.6 mm; 1 cable per acoustic path 5 m / 16 ft
	Option: max. 30m / 90 ft
Cable entries	Standard: M20 x 1.5
	Option: ½" NPT, PF ½

Inputs and outputs

General	All in-and outputs are galvanically isolated from each other and from all other circuits.		
Description of used abbreviations	U_{ext} = external voltage U_{nom} = nominal voltage U_{int} = internal voltage U_o = terminal voltage R_L = resistance of load I_{nom} = nominal current		
Current output			
Output data	Measurement of volume, enthalpy and mass (at constant density), HART [®] communication.		
Settings	Without HART[®]		
	Q = 0%: 0...15 mA		
	Q = 100%: 10...20 mA		
	Error identification: 3...22 mA		
	With HART[®]		
	Q = 0%: 4...15 mA		
	Q = 100%: 10...20 mA		
	Error identification: 3...22 mA		
Operating data	Basic I/Os	Modular I/Os	Ex-i
Active	$U_{int} = 24 \text{ VDC}$ $I \leq 22 \text{ mA}$ $R_L \leq 1 \text{ k}\Omega$		$U_{int} = 20 \text{ VDC}$ $I \leq 22 \text{ mA}$ $R_L \leq 450 \Omega$
			$U_0 = 21 \text{ V}$ $I_0 = 90 \text{ mA}$ $P_0 = 0.5 \text{ W}$ $C_0 = 90 \text{ nF} / L_0 = 2 \text{ mH}$ $C_0 = 110 \text{ nF} /$ $L_0 = 0.5 \text{ mH}$
Passive	$U_{ext} \leq 32 \text{ VDC}$ $I \leq 22 \text{ mA}$ $U_0 \geq 1.8 \text{ V}$ $R_L \leq (U_{ext} - U_0) / I_{max}$		$U_{ext} \leq 32 \text{ VDC}$ $I \leq 22 \text{ mA}$ $U_0 \geq 4 \text{ V}$ $R_L \leq (U_{ext} - U_0) / I_{max}$
			$U_1 = 30 \text{ V}$ $I_1 = 100 \text{ mA}$ $P_1 = 1 \text{ W}$ $C_1 = 10 \text{ nF}$ $L_1 = 0 \text{ mH}$

HART®			
Description	HART® protocol via active and passive current output		
	HART® version: V5		
	Universal HART® parameter: completely integrated		
Load	≥ 250 Ω at HART® test point: Note maximum load for current output!		
Multidrop	Yes, current output = 4 mA		
	Multidrop addresses adjustable in operation menu 1...15		
Device drivers	HART®, AMS DD / FDT / DTM		
Pulse or frequency output			
Output data	Pulse output: volume, enthalpy or mass counting		
	Frequency output: volume flow, enthalpy flow, mass flow, specific enthalpy, density, flow speed, velocity of sound, gain		
Function	Adjustable as pulse or frequency output		
Settings	For Q = 100%: 0.01... 10000 pulses per second or pulses per unit volume.		
	Pulse width: adjustable as automatic, symmetric or fixed (0.05...2000 ms)		
Operating data	Basic I/Os	Modular I/Os	Ex-i
Active	-	$U_{int} = 24 \text{ VDC}$ f_{max} in operating menu set to: $f_{max} \leq 100 \text{ Hz}$: $I \leq 20 \text{ mA}$ $R_{L, max} = 47 \text{ k}\Omega$ open: $I \leq 0.05 \text{ mA}$ closed: $U_{0, nom} = 24 \text{ V}$ at $I = 20 \text{ mA}$	-
		f_{max} in operating menu set to: $100 \text{ Hz} < f_{max} \leq 10 \text{ kHz}$: $I \leq 20 \text{ mA}$ $R_L \leq 10 \text{ k}\Omega$ for $f \leq 1 \text{ kHz}$ $R_L \leq 1 \text{ k}\Omega$ for $f \leq 10 \text{ kHz}$ open: $I \leq 0.05 \text{ mA}$ closed: $U_{0, nom} = 22.5 \text{ V}$ at $I = 1 \text{ mA}$ $U_{0, nom} = 21.5 \text{ V}$ at $I = 10 \text{ mA}$ $U_{0, nom} = 19 \text{ V}$ at $I = 20 \text{ mA}$	

Passive	$U_{ext} \leq 32 \text{ VDC}$		-
	f_{max} in operating menu set to: $f_{max} \leq 100 \text{ Hz}$: $I \leq 100 \text{ mA}$ $R_{L, max} = 47 \text{ k}\Omega$ $R_{L, max} = (U_{ext} - U_0) / I_{max}$ open: $I \leq 0.05 \text{ mA}$ at $U_{ext} = 32 \text{ VDC}$ closed: $U_{0, max} = 0.2 \text{ V}$ at $I \leq 10 \text{ mA}$ $U_{0, max} = 2 \text{ V}$ at $I \leq 100 \text{ mA}$		
	f_{max} in operating menu set to: $100 \text{ Hz} < f_{max} \leq 10 \text{ kHz}$: $I \leq 20 \text{ mA}$ $R_L \leq 10 \text{ k}\Omega$ for $f \leq 1 \text{ kHz}$ $R_L \leq 1 \text{ k}\Omega$ for $f \leq 10 \text{ kHz}$ $R_{L, max} = (U_{ext} - U_0) / I_{max}$ open: $I \leq 0.05 \text{ mA}$ at $U_{ext} = 32 \text{ VDC}$ closed: $U_{0, max} = 1.5 \text{ V}$ at $I \leq 1 \text{ mA}$ $U_{0, max} = 2.5 \text{ V}$ at $I \leq 10 \text{ mA}$ $U_{0, max} = 5.0 \text{ V}$ at $I \leq 20 \text{ mA}$		
NAMUR	-	Passive to EN 60947-5-6 open: $I_{nom} = 0.6 \text{ mA}$ closed: $I_{nom} = 3.8 \text{ mA}$	Passive to EN 60947-5-6 open: $I_{nom} = 0.43 \text{ mA}$ closed: $I_{nom} = 4.5 \text{ mA}$
			$U_I = 30 \text{ V}$ $I_I = 100 \text{ mA}$ $P_I = 1 \text{ W}$ $C_I = 10 \text{ nF}$ $L_I = 0 \text{ mH}$

Status output / limit switch			
Function and settings	Settable as indicator for direction of flow, overflow, error, operating point.		
	Status and/or control: ON or OFF		
Operating data	Basic I/Os	Modular I/Os	Ex-i
Active	-	$U_{int} = 24 \text{ VDC}$ $I \leq 20 \text{ mA}$ $R_{L, max} = 47 \text{ k}\Omega$ open: $I \leq 0.05 \text{ mA}$ closed: $U_{0, nom} = 24 \text{ V}$ at $I = 20 \text{ mA}$	-
Passive	$U_{ext} \leq 32 \text{ VDC}$ $I \leq 100 \text{ mA}$ $R_{L, max} = 47 \text{ k}\Omega$ $R_{L, max} = (U_{ext} - U_0) / I_{max}$ open: $I \leq 0.05 \text{ mA}$ at $U_{ext} = 32 \text{ VDC}$ closed: $U_{0, max} = 0.2 \text{ V}$ at $I \leq 10 \text{ mA}$ $U_{0, max} = 2 \text{ V}$ at $I \leq 100 \text{ mA}$	$U_{ext} \leq 32 \text{ VDC}$ $I \leq 100 \text{ mA}$ $R_{L, max} = 47 \text{ k}\Omega$ $R_{L, max} = (U_{ext} - U_0) / I_{max}$ open: $I \leq 0.05 \text{ mA}$ at $U_{ext} = 32 \text{ VDC}$ closed: $U_{0, max} = 0.2 \text{ V}$ at $I \leq 10 \text{ mA}$ $U_{0, max} = 2 \text{ V}$ at $I \leq 100 \text{ mA}$	-
NAMUR	-	Passive to EN 60947-5-6 open: $I_{nom} = 0.6 \text{ mA}$ closed: $I_{nom} = 3.8 \text{ mA}$	Passive to EN 60947-5-6 open: $I_{nom} = 0.43 \text{ mA}$ closed: $I_{nom} = 4.5 \text{ mA}$ $U_I = 30 \text{ V}$ $I_I = 100 \text{ mA}$ $P_I = 1 \text{ W}$ $C_I = 10 \text{ nF}$ $L_I = 0 \text{ mH}$

Control input			
Function	Set value of the outputs to "zero", counter and error reset, range change.		
Operating data	Basic I/Os	Modular I/Os	Ex-i
Active	-	$U_{int} = 24 \text{ VDC}$ Terminals open: $U_{0, nom} = 22 \text{ V}$ Terminals bridged: $I_{nom} = 4 \text{ mA}$ On: $U_0 \leq 10 \text{ V}$ with $I_{nom} = 1.9 \text{ mA}$ Off: $U_0 \geq 12 \text{ V}$ with $I_{nom} = 1.9 \text{ mA}$	-
Passive	$U_{ext} \leq 32 \text{ VDC}$ $I_{max} = 6.5 \text{ mA}$ at $U_{ext} \leq 24 \text{ VDC}$ $I_{max} = 8.2 \text{ mA}$ at $U_{ext} \leq 32 \text{ VDC}$ Contact closed (On): $U_0 \geq 8 \text{ V}$ with $I_{nom} = 2.8 \text{ mA}$ Contact open (Off): $U_0 \leq 2.5 \text{ V}$ with $I_{nom} = 0.4 \text{ mA}$	$U_{ext} \leq 32 \text{ VDC}$ $I_{max} = 9.5 \text{ mA}$ at $U_{ext} \leq 24 \text{ V}$ $I_{max} = 9.5 \text{ mA}$ at $U_{ext} \leq 32 \text{ V}$ Contact closed (On): $U_0 \geq 3 \text{ V}$ with $I_{nom} = 1.9 \text{ mA}$ Contact open (Off): $U_0 \leq 2.5 \text{ V}$ with $I_{nom} = 1.9 \text{ mA}$	$U_{ext} \leq 32 \text{ VDC}$ $I \leq 6 \text{ mA}$ at $U_{ext} = 24 \text{ V}$ $I \leq 6.6 \text{ mA}$ at $U_{ext} = 32 \text{ V}$ On: $U_0 \geq 5.5 \text{ V}$ or $I \geq 4 \text{ mA}$ Off: $U_0 \leq 3.5 \text{ V}$ or $I \leq 0.5 \text{ mA}$ $U_1 = 30 \text{ V}$ $I_1 = 100 \text{ mA}$ $P_1 = 1 \text{ W}$ $C_1 = 10 \text{ nF}$ $L_1 = 0 \text{ mH}$
NAMUR	-	Active to EN 60947-5-6 Contact open: $U_{0, nom} = 8.7 \text{ V}$ Contact closed (On): $I_{nom} = 7.8 \text{ mA}$ Contact open (off): $U_{0, nom} = 6.3 \text{ V}$ with $I_{nom} = 1.9 \text{ mA}$ Identification for open terminals: $U_0 \geq 8.1 \text{ V}$ with $I \leq 0.1 \text{ mA}$ Identification for short circuited terminals: $U_0 \leq 1.2 \text{ V}$ with $I \geq 6.7 \text{ mA}$	-

Low-flow cutoff			
On	0...±9.999 m/s; 0...20.0%, settable in 0.1% steps, separately for each current and pulse output.		
Off	0...±9.999 m/s; 0...19.0%, settable in 0.1% steps, separately for each current and pulse output.		
Time constant			
Function	Can be set together for all flow indicators and outputs, or separately for: current, pulse and frequency output, and for limit switches and the 3 internal counters.		
Time setting	0...100 seconds, settable in 0.1 second steps.		
Current input			
Function	For conversion to standard conditions, input from external temperature and pressure transmitters is required.		
Operating data	Basic I/Os	Modular I/Os	Ex i
Active	-	$U_{int} = 24 \text{ VDC}$ $I \leq 22 \text{ mA}$ $I_{max} \leq 26 \text{ mA}$ (electronically limited) $U_{0, min} = 19 \text{ V}$ at $I \leq 22 \text{ mA}$	$U_{int} = 20 \text{ VDC}$ $I \leq 22 \text{ mA}$ $U_{0, min} = 14 \text{ V}$ at $I \leq 22 \text{ mA}$
			No HART®
		No HART®	$U_0 = 24.1 \text{ V}$ $I_0 = 99 \text{ mA}$ $P_0 = 0.6 \text{ W}$ $C_0 = 75 \text{ nF} / L_0 = 0.5 \text{ mH}$
		No HART®	No HART®
Passive	-	$U_{ext} \leq 32 \text{ VDC}$ $I \leq 22 \text{ mA}$ $I_{max} \leq 26 \text{ mA}$ (electronically limited) $U_{0, min} = 5 \text{ V}$ at $I \leq 22 \text{ mA}$	$U_{ext} \leq 32 \text{ VDC}$ $I \leq 22 \text{ mA}$ $U_{0, min} = 4 \text{ V}$ at $I \leq 22 \text{ mA}$
			No HART®
		No HART®	$U_I = 30 \text{ V}$ $I_I = 100 \text{ mA}$ $P_I = 1 \text{ W}$ $C_I = 10 \text{ nF}$ $L_I = 0 \text{ mH}$
		No HART®	No HART®

MODBUS (in preparation)	
Description	Modbus RTU, Master / Slave, RS485
Address range	1...247
Supported function codes	03, 04, 16
Broadcast	Supported with function code 16
Supported Baudrate	1200, 2400, 4800, 9600, 19200, 38400, 57600, 115200 Baud

Approvals and certificates

CE	
	This device fulfills the statutory requirements of the EC directives. The manufacturer certifies successful testing of the product by applying the CE mark.
Electromagnetic compatibility	Directive: 2004/108/EC, NAMUR NE21/04
	Harmonized standard: EN 61326-1 : 2006
Low Voltage Directive	Directive: 2006/95/EC
	Harmonized standard: EN 61010 : 2001
Pressure Equipment Directive	Directive: 97/23/EC
	Category I, II or SEP
	Fluid group 1
	Production module H
Other approvals and standards	
Non-Ex	Standard
Namur	NE 21, 45, 53, 80
Hazardous areas	
	For detailed information, please refer to the relevant Ex documentation.
ATEX	DEKRA 12 ATEX 0063 X
Protection category acc. to IEC 529 / EN 60529	Signal converter
	Field (F): IP 65 (NEMA 4X/6)
	All flow sensors
	IP 67 (NEMA 6)
Vibration resistance	IEC 68-2-64
Shock resistance	IEC 68-2-27

8.3 Dimensions and weights

8.3.1 Flow sensor

The OPTISONIC 8300 will primarily be welded to the connecting piping. The design of the tube of the OPTISONIC 8300 will be based on the specifications of the connecting piping. Detailed information for the dimensions and weights can not be specified as they will vary with each application. The information below should therefore be regarded as indicative.



INFORMATION!

Please note size *d*, the required extra space for installation and maintenance of the transducers.

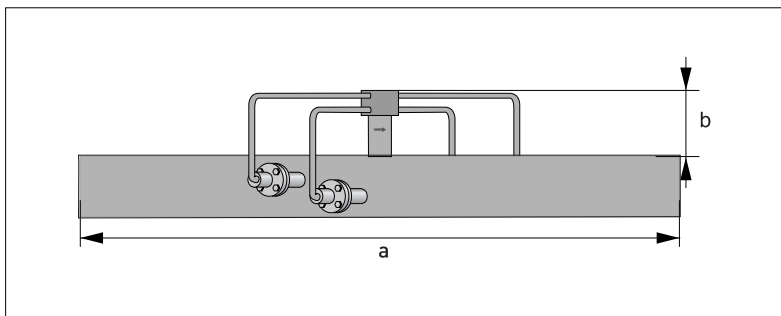

Figure 8-2: Front view of the GFS 8000

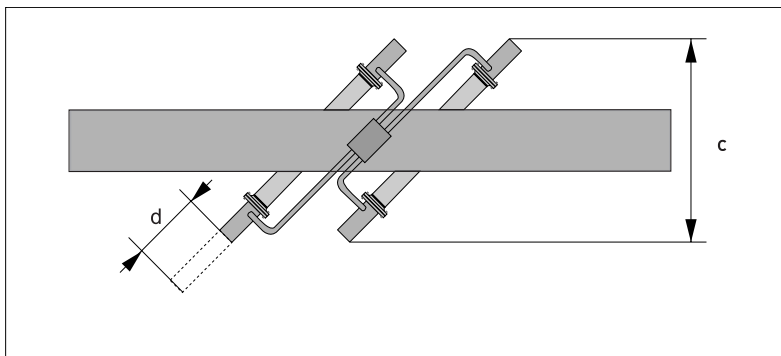

Figure 8-3: Upper view of the GFS 8000

Dimensions of the GFS 8000 in mm and inches

	[mm]	[inches]
a	DN100 / 4": 1000	DN100 / 4": 39.37
	DN150...600 / 6...24": 2000	DN150...600 / 6...24": 87.74
b	265	10.43
c	Transducer flange rating 600 lbs: 1184 + Di	600 lbs: 46.61 + Di
	Transducer flange rating 1500 lbs: 1205 + Di	1500 lbs: 47.44 + Di
d	300	11.81

8.3.2 Converter housing

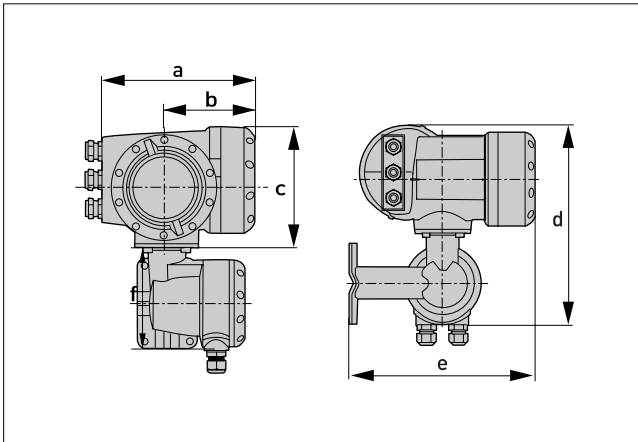

Figure 8-4: Field housing (F) - remote version.

Dimensions and weights in mm and kg

Dimensions [mm]					Weight [kg]
a	b	c	d	e	
202	120	155	295.8	277	5.7

Dimensions and weights in inches and lb

Dimensions [inches]					Weight [lb]
a	b	c	d	e	
7.75	4.75	6.10	11.60	10.90	12.60

8.3.3 Mounting plate, field housing

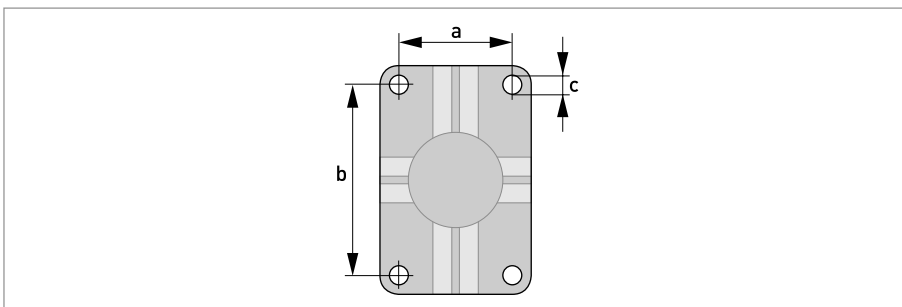

Dimensions in mm and inches

	[mm]	[inches]
a	60	2.4
b	100	3.9
c	∅ 9	∅ 0.4

9.1 General description

The open HART[®] protocol, which can be used freely, is integrated into the signal converter for communication.

Devices which support the HART[®] protocol are classified as either operating devices or field devices. When it comes to operating devices (Master), both manual control units (Secondary Master) and PC-supported workstations (Primary Master) are used in, for example, a control centre.

HART[®] field devices include measuring sensors, signal converters and actuators. The field devices range from 2-wire to 4-wire to intrinsically safe versions for use in hazardous areas.

The HART[®] data are superimposed over the analogue 4...20 mA signal via FSK modem. This way, all of the connected devices can communicate digitally with one another via the HART[®] protocol while simultaneously transmitting the analogue signals.

When it comes to the field devices and secondary masters, the FSK or HART[®] modem is integrated, whereas with a PC communication takes place via an external modem which must be connected to the serial interface. There are, however, other connection variants which can be seen in the following connection figures.

9.2 Software history



INFORMATION!

In the table below, "x" is a placeholder for possible multi-digit alphanumeric combinations, depending on the available version.

Release date	Electronic Revision	SW.REV.UIS	SW.REV.MS	HART [®]	
				Device Revision	DD Revision
2012-03		1.x.x	1.x.x	2	1

HART[®] identification codes and revision numbers

Manufacturer ID:	69 (0x0045)
Device:	0x45D5
Device Revision:	2
DD Revision	1
HART [®] Universal Revision:	5
FC 375/475 system SW.Rev.:	≥ 3.5 (HART App5)
AMS version:	≥ 11.1
PDM version:	≥ 6.0
FDM version:	≥ 4.10

9.3 Connection variants

The signal converter is a 4-wire device with 4...20 mA current output and HART[®] interface. Depending on the version, the settings and the wiring, the current output can operate as passive or active output.

- **Multi-Drop Mode is supported**
In a Multi-Drop communication system, more than 2 devices are connected to a common transmission cable.
- **Burst Mode is not supported**
In the Burst Mode a slave device transfers cyclic pre-defined response telegrams, to get a higher rate of data transfer.



INFORMATION!

For detailed information about the electrical connection of the signal converter for HART[®], refer to the section "Electrical connection".

There are two ways of using the HART[®] communication:

- as Point-to-Point connection and
- as multi-drop connection, with 2-wire connection or as multi-drop connection, with 3-wire connection.

9.3.1 Point-to-Point connection - analogue / digital mode

Point-to-Point connection between the signal converter and the HART[®] Master.

The current output of the device may be active or passive.

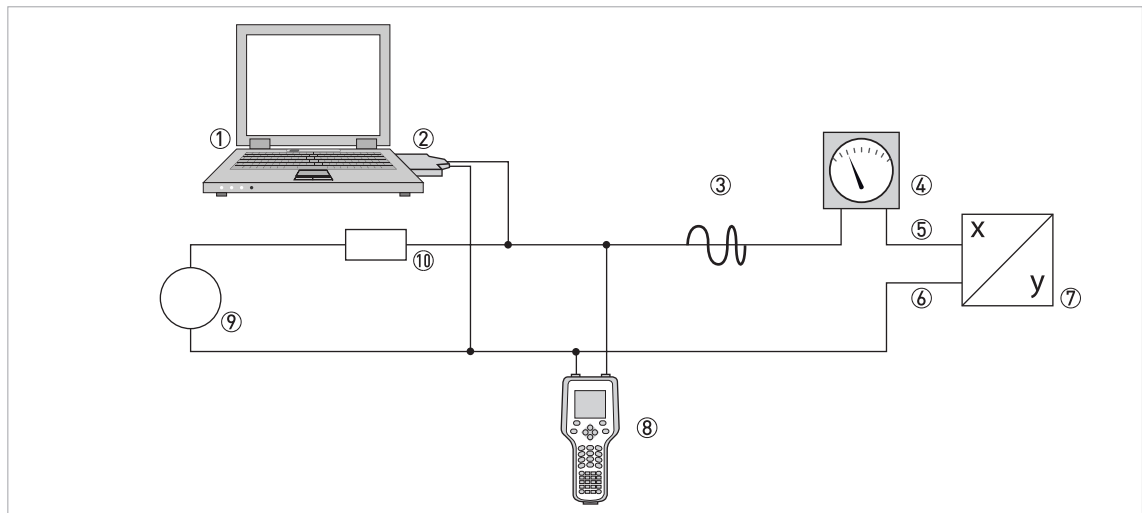

- ① Primary master
- ② FSK modem or HART[®] modem
- ③ HART[®] signal
- ④ Analog indication
- ⑤ Signal converter terminals A (C)
- ⑥ Signal converter terminals A- (C-)
- ⑦ Signal converter with address = 0 and passive or active current output
- ⑧ Secondary Master
- ⑨ Power supply for devices (slaves) with passive current output
- ⑩ Load $\geq 250 \Omega$ (0hm)

9.3.2 Multi-Drop connection (2-wire connection)

In the case of a multi-drop connection, up to 15 devices may be installed in parallel (this signal converter and other HART® devices).

The current outputs of the devices must be passive!

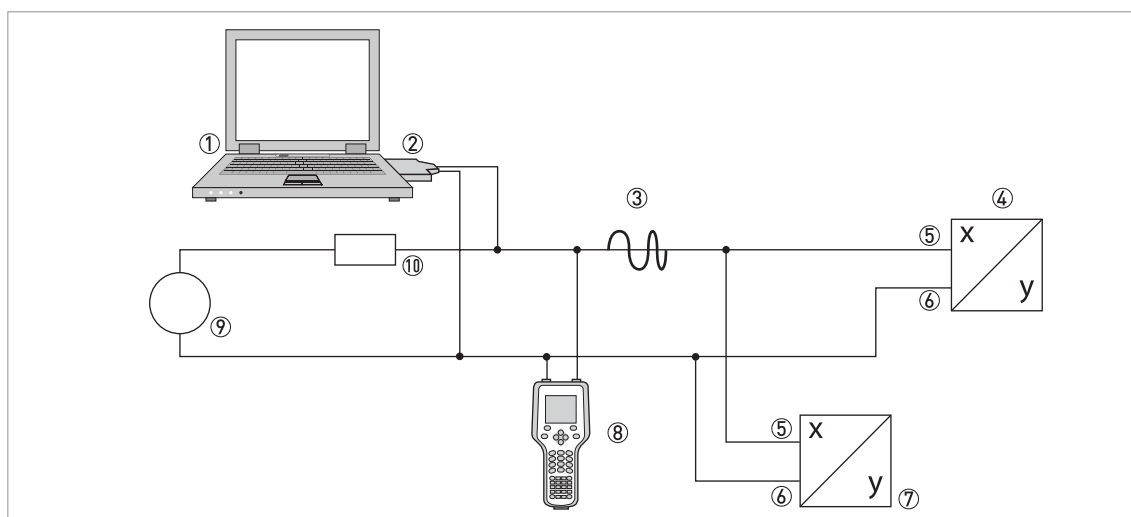

- ① Primary Master
- ② HART® modem
- ③ HART® signal
- ④ Other HART® devices or this signal converter (see also ⑦)
- ⑤ Signal converter terminals A (C)
- ⑥ Signal converter terminals A- (C-)
- ⑦ Signal converter with address > 0 and passive current output, connection of max. 15 devices (slaves) with 4...20 mA
- ⑧ Secondary Master
- ⑨ Power supply
- ⑩ Load $\geq 250 \Omega$ (Ohm)

9.3.3 Multi-Drop connection (3-wire connection)

Connection of 2-wire and 4-wire devices in the same network. In order that the current output of the signal converter is working continuously active, an additional third wire must be connected to the devices in the same network. These devices must be powered via a 2-wire loop.

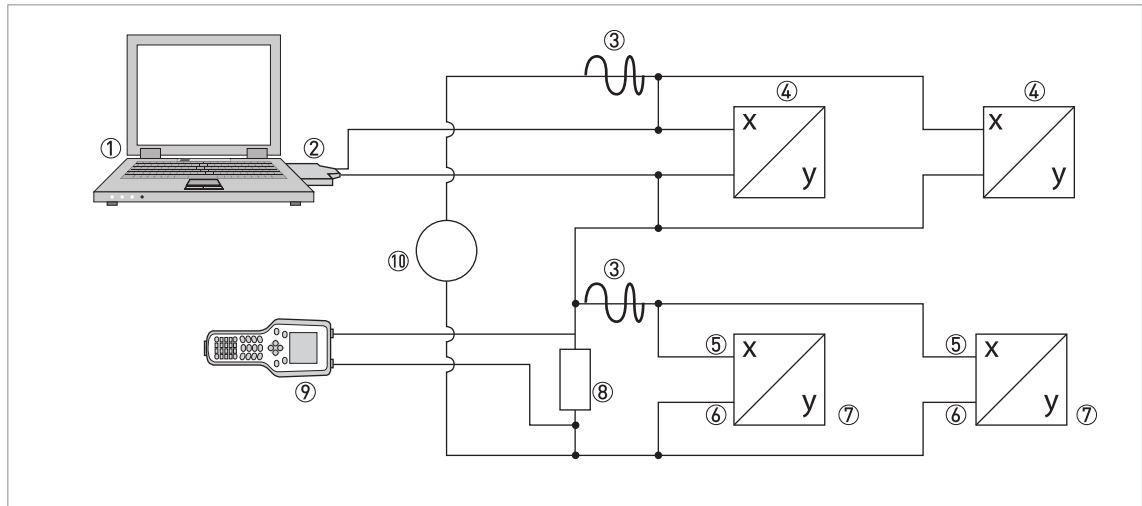

- ① Primary Master
- ② HART[®] modem
- ③ HART[®] signal
- ④ 2-wire external devices (slaves) with 4...20 mA, addresses > 0, powered by current loop
- ⑤ Signal converter terminals A (C)
- ⑥ Signal converter terminals A- (C-)
- ⑦ Connection of active or passive 4-wire devices (slaves) with 4...20 mA, addresses > 0
- ⑧ Load $\geq 250 \Omega$ (Ohm)
- ⑨ Secondary Master
- ⑩ Power supply

9.4 Inputs/outputs and HART[®] dynamic variables and device variables

The signal converter is available with various in-/output combinations.

The connection of the terminals A...D to the HART[®] dynamic variables PV, SV, TV and QV depends on the device version.

PV = Primary Variable; SV = Secondary Variable; TV = Third Variable; QV = Quarternary Variable

Signal converter version	HART [®] dynamic variable			
	PV	SV	TV	QV
Basic I/O, connection terminals	A	D	-	-
Modular I/O and Ex i I/O, connection terminals	C	D	A	B

The signal converter can provide up to 14 measurement-related values. These values are accessible as so-called HART[®] device variables and can be connected to the HART[®] dynamic variables. The availability of these variables depends on the device versions and the settings.

Code = device variable code

Device variables

HART [®] device variable	Code	Type	Explanations
volume flow	20	linear	
corrected volume flow	21	linear	
mass flow	22	linear	
molar mass	23	linear	
flow speed	25	linear	
velocity of sound	26	linear	
signal gain	27	linear	
diagnosis 1	28	linear	Function and availability depends on diagnosis 1 value setting.
diagnosis 2	29	linear	Function and availability depends on diagnosis 2 value setting.
diagnosis 3	30	linear	Function and availability depends on diagnosis 3 value setting.
counter 1 (C)	6	totaliser	Valid for Basic I/O option only.
counter 1 (B)	13	totaliser	Valid for Modular I/O and Ex i I/O options only.
counter 2 (D)	14	totaliser	-
counter 3 (A)	12	totaliser	Valid for Modular I/O and Ex i I/O options only.

For the dynamic variables connected to the linear analogue outputs (for current and/or frequency) are assigned by selecting the measurement for the related outputs. Only linear device variables can be assigned in this case.

For dynamic variables not connected to linear analogue outputs both linear and totaliser device variables can be assigned.

9.5 Remote operation

In addition to the local user interface panel the device may be operated remotely via the communication interface. There are different operating tools including small handhelds and large integrated maintenance systems. For adaptation to different devices two main technologies are used: The Device Description (DD) and the Field Device Tool Device Type Manager (FDT DTM). Both a DD and a DTM contain the description of a device's user interface, parameter database and communication interface. After being installed in an operating tool they allow access to device specific data. In the DD environment an operating tool is usually referred to as "host"; in the FDT DTM environment it is called "frame application" or "FDT container".

A DD is sometimes also referred to as EDD for Enhanced Device Description. This emphasizes some enhancements in specification like e.g. GUI support but doesn't imply a new technology.

For improving interoperability between DD hosts standard menu entry points have been specified:

- Root Menu
Default top level menu for DD host applications with limited display space (e.g. handhelds).
- Process Variables Root Menu
Provides process measurements and set points. For GUI based DD host applications.
- Diagnostic Root Menu
Shows device state and diagnostic information. For GUI based DD host applications.
- Device Root Menu
Provides access to all field device capabilities. For GUI based DD host applications.
- Offline Root Menu
Provides access to all field device capabilities that can be manipulated while the host application is not connected to the field device.

For detailed information about the standard menus refer to *HART Menu Tree* on page 123.

The support of the standard menu entry points by the different DD hosts is described next.

9.5.1 Online/offline operation

DD hosts have different characteristics and support different operating modes for configuring devices, online and offline mode.

In online mode the host application can currently communicate with the device. The device can immediately check and perform configuration changes and update dependent parameters in case.

In offline mode the host application works only with a copy of the device's configuration data set and the DD needs to imitate the device's checks and updates.

Unfortunately the DD isn't informed by the host whether it is running in online or offline mode. In order to avoid interference between update functionality of the DD and the device there is a local parameter "Online Mode?" in the "Detailed Setup / HART" menu which can be set accordingly by the user.

9.5.2 Parameters for the basic configuration

There are parameters, such as measurement of counters, selection of diagnosis values and setting of pressure and temperature correction, which require a warm start of the device following data changes before other parameters may be written. Depending on the operating mode of the host system (online/offline mode) these parameters need to be treated differently.

In online mode the settings should be changed with the corresponding online methods only, in order to perform the warm start immediately and update dependent parameters automatically afterwards.

In the menu tree these methods are located below the related parameters (e.g. in a counter menu the method "Select Measurement" below the parameter "Measurement").

In offline mode the parameter "Online Mode?" in the "Detailed Setup / HART" menu should be set to "no" before the configuration settings are changed as desired. Before writing the entire offline configuration data set to the device the method "Prepare Parameter Download" in the "Detailed Setup / HART" menu should be executed. This method writes the parameters for basic configuration to the device and performs a warm start afterwards.



INFORMATION!

The Emerson Field Communicator and Simatic PDM execute this method automatically before sending a configuration or performing a "Download to Device" respectively.

9.5.3 Units

There are separate physical units settings for configuration parameters and HART[®] dynamic/device variables. The units settings for configuration parameters are the same as on the device's local display. They are available in the menu "Detailed Setup / Device / Units". For each HART[®] dynamic/device variable the physical unit can be set individually. They are available in the menu "Detailed Setup / Process Input / HART". The different units settings can be aligned with the method "Align HART Units" in the menu "Detailed Setup / Process Input / HART".

9.6 Field Communicator 375/475 (FC 375/475)

The Field Communicator is a hand terminal from Emerson Process Management that is designed to configure HART[®] and Foundation Fieldbus devices. Device Descriptions (DDs) are used to integrate different devices into the Field Communicator.

9.6.1 Installation

The HART[®] Device Description for the signal converter must be installed on the Field Communicator. Otherwise only the functions of a generic DD are available to the user and the entire device control is not possible. A "Field Communicator Easy Upgrade Programming Utility" is required to install the DDs on the Field Communicator.

The Field Communicator must be equipped with a system card with "Easy Upgrade Option". For details consult the Field Communicator User's Manual.

9.6.2 Operation

The Field Communicator supports the DD Root Menu for online access to the device. The Root Menu is implemented as a combination of the other standard menus Process Variables Root Menu, Diagnostic Root Menu and Device Root Menu.



INFORMATION!

For more detailed information see Appendix A, HART Menu Tree Field Communicator HART Application on page 123.

Operating the signal converter via the Field Communicator is very similar to manual device control using the keyboard. The help attribute of each parameter contains its function number as a reference to the local device display and the handbook.

Parameter protection for custody transfer is the same as on the device's local display. Other specific protective functions such as the passwords for the quick setup menu and the setup menu are not supported with HART®.

The Field Communicator always saves a complete configuration for the exchange with AMS. However, in the offline configuration and when sending to the device, the Field Communicator only takes into account a partial parameter set (like the standard configuration of the old HART® Communicator 275).

9.7 Asset Management Solutions (AMS)

The Asset Management Solutions Device Manager (AMS) is a PC program from Emerson Process Management which is designed to configure and manage HART[®], PROFIBUS and Foundation-Fieldbus devices. Device Descriptions (DDs) are used to integrate different devices into the AMS.

9.7.1 Installation

If the signal converter Device Description has not yet been installed on the AMS system, a so-called Installation Kit HART[®] AMS is required. It is available for download from the website or on CD ROM.

For installation with the Installation Kit refer to the "AMS Intelligent Device Manager Books Online" section "Basic Functionality / Device Information / Installing Device Types".



INFORMATION!

Please read the "readme.txt", which is also contained in the Installation Kit.

9.7.2 Operation

AMS supports the Process Variables Root Menu, Diagnostic Root Menu and Device Root Menu for online access to the device.



INFORMATION!

For more detailed information see Appendix A, Menu Tree AMS on page 124.

Operating the signal converter via the AMS Device Manager is similar to manual device control using the keyboard. The help attribute of each parameter contains its function number as a reference to the local device display and the handbook.

Parameter protection for custody transfer and service is the same as on the device's local display. Other specific protective functions such as the passwords for the quick setup menu and the setup menu are not supported with HART[®].

When copying configurations in AMS, unit parameters need to be transferred first. Otherwise related parameters may be not transferred correctly. When the compare view has been opened during a copy process, go at first to the units section of the device menu ("Detailed Setup / Device / Units") and transfer all unit parameters. Note that read-only parameters need to be transferred individually!

9.8 Process Device Manager (PDM)

The Process Device Manager (PDM) is a Siemens PC program designed to configure HART® and PROFIBUS devices. Device Descriptions (DDs) are used to integrate different devices into the PDM.

9.8.1 Installation

If the signal converter Device Description has not yet been installed on the PDM system, a so-called Device Install HART® PDM is required for the signal converter. This is available for download from the website or on CD-ROM.

For installation with the Device Install, see the PDM manual, Section 13 - Integrating devices.



INFORMATION!

Please read the "readme.txt", which is also contained in the Installation Kit.

9.8.2 Operation

PDM supports the Process Variables Root Menu, Diagnostic Root Menu and Device Root Menu for online access to the device and the Offline Root Menu for offline configuration.



INFORMATION!

For more detailed information see Appendix A, Menu Tree PDM on page 125.

The classic approach for PDM is the offline operation with the PDM parameter table and the transfer of entire configuration data sets with the "Download to Device" and "Upload to PG/PC" functions. The parameter "Online Mode?" in the "Detailed Setup / HART" table section of the parameter table should be set to "no". However PDM also supports online operation from the "Device" and the "View" sections of the menu bar which is more similar to manual device control using the keyboard. Usually offline and online configuration data sets are separated in PDM. Still there is some interdependency e.g. regarding evaluation of parameter and menu conditionals: If e.g. the "Access Level" is changed in an online menu the offline configuration data set needs to be updated with "Upload to PG/PC" before the related online menus actually become accessible.

The help attribute of each parameter contains its function number as a reference to the local device display and the handbook.

Parameter protection for custody transfer and service is the same as on the device's local display. Other specific protective functions such as the passwords for the quick setup menu and the setup menu are not supported with HART®.

9.9 Field Device Manager (FDM)

A Field Device Manager (FDM) is basically a PC program from Honeywell used to configure HART[®], PROFIBUS and Foundation Fieldbus devices. Device Descriptions (DDs) and Device Type Managers (DTMs) are used to integrate different devices into the FDM.

9.9.1 Installation

If the signal converter Device Description has not yet been installed on the FDM system, the Device Description is required in binary format and is available for download from the website or on CD ROM.

For information on installing the Device Description, refer to the FDM User Guide - section 4.8 Managing DDs.

9.9.2 Operation

FDM supports the Process Variables Root Menu, the Diagnostic Root Menu and the Device Root Menu for online access to the device and the Offline Root Menu for offline configuration.



INFORMATION!

For more detailed information see Appendix A, HART Menu Tree FDM on page 126.

The help attribute of each parameter contains its function number as a reference to the local device display and the handbook.

Parameter protection for custody transfer is the same as on the device's local display. Other specific protective functions such as the passwords for the quick setup menu and the setup menu are not supported with HART[®].

9.10 Field Device Tool Device Type Manager (FDT DTM)

A Field Device Tool Container or Frame Application is basically a PC program used to configure HART[®], PROFIBUS and Foundation Fieldbus devices. Device Type Managers (DTMs) are used to integrate different devices into a FDT container.

9.10.1 Installation

If the Device Type Manager for the signal converter has not yet been installed on the FDT Container, a setup is required which is available for download from the website or on CD-ROM.

See the supplied documentation for information on how to install and set up the DTM.

9.10.2 Operation

Operating the signal converter via DTM is very similar to manual device control using the keyboard. See also the local device display and the handbook.

9.11 HART Menu Tree

9.11.1 HART Menu Tree - Field Communicator HART Application

The Field Communicator supports the standard EDDL Root Menu.

In the signal converter HART DD it is implemented as a combination of other standard EDDL menus:

- Process Variables Root Menu (details on page 127)
- Diagnostic Root Menu (details on page 128)
- Device Root Menu (details on page 130)

The menus are located in the Field Communicator user interface as follows:

Field Communicator HART Application

1 Offline	
2 Online	1 Process Variables (Process Variables Root Menu)
	2 Diag/Service (Diagnostic Root Menu)
	3 Quick Setup (Device Root Menu)
	4 Detailed Setup (Device Root Menu)
	5 Service (Device Root Menu)
3 Utility	
4 HART Diagnostics	

9.11.2 HART Menu Tree AMS - Device's context menu

AMS supports the following standard EDDL menus:

- Process Variables Root Menu (details on page 127)
- Diagnostic Root Menu (details on page 128)
- Device Root Menu (details on page 130)

The menus are located in the AMS user interface as follows:

Device's context menu

Configure/Setup	Configure/Setup (Device Root Menu)
Compare	
Clear Offline	
Device Diagnostics	Device Diagnostics (Diagnostic Root Menu)
Process Variables	Process Variables (Process Variables Root Menu)
Scan Device	
Calibration Management	
Rename	
Unassign	
Assign / Replace	
Audit Trail	
Record Manual Event	
Drawings / Notes...	
Help...	

9.11.3 HART Menu Tree PDM - Menu Bar and Working Window

PDM supports the following standard EDDL menus:

- Process Variables Root Menu (details on page 127)
- Diagnostic Root Menu (details on page 128)
- Device Root Menu (details on page 130)
- Offline Root Menu (details on page 133)

The menus are located in the PDM user interface as follows:

Menu Bar

File	
Device	Communication path
	Download to Device...
	Upload to PG/PC...
	Update Diagnostic Status
	Quick Setup (Device Root Menu)
	Detailed Setup (Device Root Menu)
	Service (Device Root Menu)
View	Process Variables (Process Variables Root Menu)
	Diag/Service (Diagnostic Root Menu)
	Toolbar
	Status Bar
	Update
Options	
Help	

Working Window

Parameter Group Overview	(Offline Root Menu)
Parameter Table	

9.11.4 HART Menu Tree FDM - Device Configuration

FDM supports the following standard EDDL menus:

- Root Menu
- Process Variables Root Menu (details on page 127)
- Diagnostic Root Menu (details on page 128)
- Device Root Menu (details on page 130)

In the signal converter HART DD the Root Menu it is implemented as a combination of the other standard EDDL menus.

The menus are located in the FDM user interface as follows:

Device Configuration Window

Entry Points
Device Functions
Online (Root Menu)
Device (Device Root Menu)
Process Variables (Process Variables Root Menu)
Diagnostic (Diagnostic Root Menu)
Method List
FDM Status
FDM Device Properties
FDM Tasks
...

9.11.5 Description of used abbreviations

- ^{Opt} Optional, depending on device implementation/configuration
- Rd Read only
- ^{Loc} Local DD, affects only DD views
- ^{Cust} Custody lock protection

9.11.6 Process Variables Root Menu

Measured Values Overview

<ul style="list-style-type: none"> • Actual FlowRd • Corrected Flow^{Rd, Opt} • Enthalpy Flow^{Rd, Opt} • Mass FlowRd • Molar Mass^{Rd, Opt} • Specific Enthalpy^{Rd, Opt} • Density^{Rd, Opt} • Flow SpeedRd 	<ul style="list-style-type: none"> • Velocity of SoundRd • GainRd • Diagnostics 1^{Rd, Opt} • Diagnostics 2^{Rd, Opt} • Diagnostics 3^{Rd, Opt} • Counter 1Rd • Counter 2Rd • Counter 3Rd
----------------------------------------------------------------------------------------------------------------------------------------------------------------------------------------------------------------------------------------------------------------------------------------------------------------------------------------------------------------------	--------------------------------------------------------------------------------------------------------------------------------------------------------------------------------------------------------------------------------------------------------------------------------------------------------------------------------------------------------

Output, HART Dynamic Variables

<p>Primary</p> <ul style="list-style-type: none"> • Measured ValueRd • Percent RangeRd • Loop CurrentRd 	<p>Secondary</p> <ul style="list-style-type: none"> • Measured ValueRd • Percent RangeRd • Output Value^{Rd, Opt}
<p>Tertiary</p> <ul style="list-style-type: none"> • Measured ValueRd • Percent RangeRd • Output Value^{Rd, Opt} 	<p>Quaternary</p> <ul style="list-style-type: none"> • Measured ValueRd • Percent RangeRd • Output Value^{Rd, Opt}

Output (Chart)

<p>Output (Bar)</p> <ul style="list-style-type: none"> • PV Measured ValueRd • PV Loop CurrentRd • SV Measured Value^{Rd, Opt} • SV Output Value^{Rd, Opt} • TV Measured Value^{Rd, Opt} • TV Output Value^{Rd, Opt} • QV Measured Value^{Rd, Opt} • QV Output Value^{Rd, Opt} 	<p>Output (Scope)</p> <ul style="list-style-type: none"> • PV Measured ValueRd • PV Output ValueRd • SV Measured Value^{Rd, Opt} • SV Output Value^{Rd, Opt} • TV Measured Value^{Rd, Opt} • TV Output Value^{Rd, Opt} • QV Measured Value^{Rd, Opt} • QV Output Value^{Rd, Opt}
------------------------------------------------------------------------------------------------------------------------------------------------------------------------------------------------------------------------------------------------------------------------------------------------------------------------------------------------------------------------------------------------------------------------------------	--------------------------------------------------------------------------------------------------------------------------------------------------------------------------------------------------------------------------------------------------------------------------------------------------------------------------------------------------------------------------------------------------------------------------------------

9.11.7 Diagnostic Root Menu

Status

Standard	Device status Rd	Primary variable outside the operation limits
		Non-primary variable outside the operation limits
		Analog output outside the operating range limits
		Analog output in fixed mode
		More status available
		Cold start occurred
		Configuration changed
	Field device malfunctioned	
	Write Protect Rd	
Failure (device)	Failure (device) 1Rd F error in device / F IO1 / F parameter / F IO2 / F configuration / F display / F current in-/output A / F current in-/output B /	
	Failure (device) 2Rd F current output C / F software user interface / F hardware settings / F hardware detection / F RAM/ROM error IO1 / F RAM/ROM error IO2 / F Fieldbus	
	Failure (device) 3Rd F communication dsp-up / F sensor driver / F uProc. / F dsp / F parameter frontend	
Failure (application)	Failure (application) 1Rd F application error / F open circuit A / F open circuit B / F open circuit C / F over range A (current) / F over range B (current) / F over range C / F over range A (pulse)	
	Failure (application) 2Rd F over range B (pulse) / F over range D / F active settings / F factory settings / F backup 1 settings / F backup 2 settings / F wiring A (output) / F wiring B (output)	
	Failure (application) 3Rd F wiring A (input) / F wiring B (input) / F flow exceeding limit / F signal lost path 1 / F signal lost path 2 / F signal lost path 3	
	Failure (application) 4Rd F transducer delay / F temperature input / F pressure input / F p&t input / F VoS monitor	
Out of specification	Out of specification 1Rd S out of specification / S overflow counter 1 (C) / S overflow counter 1 (B) / S overflow counter 2 / S overflow counter 3 / S backplane invalid / S error current A / S error current B	
	Out of specification 2Rd S unreliable 1 / S unreliable 2 / S unreliable 3 / S front end calibration / S dsp timing error	
Check function & Information	Check functionRd C checks in progress / C simulation flow / C simulation VoS / C simulation fieldbus	
	Information 1Rd I counter 1 stopped (C) / I counter 1 stopped (B) / I counter 2 stopped / I counter 3 stopped / I power fail / I control input A active / I control input B active / I over range display 1	
	Information 2Rd I over range display 2 / I backplane sensor / I backplane settings / I backplane difference / I optical interface	
	Information 3Rd I start up	

Simulation

Process Input	<Simulation Volume Flow> / <Simulation Velocity of Sound>
Input/Output	<Simulation A> / <Simulation B> / <Simulation C> / <Simulation D>

Actual Values

Actual Values	Actual Volume Flow Rd / Actual Corrected Flow ^{Rd, Opt} / Actual Enthalpy Flow ^{Rd, Opt} / Actual Mass Flow ^{Rd, Opt} / Actual Molar Mass ^{Rd, Opt} / Actual Specific Enthalpy ^{Rd, Opt} / Actual Density ^{Rd, Opt} / Actual Dynamic Viscosity ^{Rd, Opt} / Actual Flow Speed Rd / Actual Pressure ^{Rd, Opt} / Actual Temperature ^{Rd, Opt} / Actual Current Input A ^{Rd, Opt} / Actual Current Input B ^{Rd, Opt} / Operating Hours Rd
Velocity of Sound	Actual VoS Path 1 Rd / Actual VoS Path 2 ^{Rd, Opt} / Actual VoS Path 3 ^{Rd, Opt}
Gain	Actual Gain Path 1 Rd / Actual Gain Path 2 ^{Rd, Opt} / Actual Gain Path 3 ^{Rd, Opt}
Signal to Noise Ratio	Actual SNR Path 1 Rd / Actual SNR Path 2 ^{Rd, Opt} / Actual SNR Path 3 ^{Rd, Opt}

Information

Information	C number Rd /
Process Input	<Sensor CPU> / <Sensor DSP> / <Sensor Driver>
<SW.REV.MS>	-
<SW.REV.UIS>	-
Electronic Revision ER>	-

Test/Reset

Test/Reset	<List Errors> / <Reset Errors> / <Warmstart> / <Device reset> / <Reset Configuration Changed Flag> / <Read GDC Object> ^{Opt} / <Write GDC Object> ^{Opt}
------------	---------------------------------------------------------------------------------------------------------------------------------------------------------------------------------

9.11.8 Device Root Menu

Quick Setup

Quick Setup	Language / Tag / Polling Address / <Reset Errors> ^{Opt} Reset Counter 1 / Reset Counter 2 / Reset Counter 3 ^{Opt}
-------------	----------------------------------------------------------------------------------------------------------------------------------------

Detailed Setup

Process Input

Calibration	Meter Size / <Zero Calibration> / GK
Filter	Minimum Limit / Maximum Limit / Flow Direction / Time Constant / Threshold Low Flow Cutoff / Hysteresis Low Flow Cutoff
Plausibility	Error Limit / Counter Decrease / Counter Limit
Simulation	<Simulation Volume Flow> / <Simulation Velocity of Sound>
Information	<Sensor CPU> / <Sensor DSP> / <Sensor Driver> / <Calibration Date> / <Calibration Date> / Serial Number Sensor / V Number Sensor
VoS monitor ^{Opt}	Monitor Velocity of Sound Monitor Settings ^{Opt} Matching Factor / Actual Ratio Measurement/Calibration / <New Match?> / VoS Tolerance / Time Constant
Linearization	Linearization / Dynamic Viscosity ^{Opt}
General ^{Opt}	Adiabatic Index
P&T Correction ^{Opt}	P&T Correction / <Set P&T Correction> / P&T Inputs ^{Opt} / Pipe Temperature ^{Opt} / Pipe Pressure ^{Opt} / Density ^{Opt}
Diagnosis Value	Diagnosis 1 / <Set Diagnosis 1> / Diagnosis 2 / <Set Diagnosis 2> / Diagnosis 3 / <Set Diagnosis 3>
HART	Sensor s/n / <Align HART Units> Actual Flow, Corrected Flow ^{Opt}, Enthalpy Flow ^{Opt}, Mass Flow , ... Unit / Format / Upper Sensor Limit / Lower Sensor Limit / Minimum Span

I/O

Hardware	Terminals A / Terminals B / Terminals C / Terminals D
Current Output A/B/C ^{Opt}	Range 0% ^{Cust} / Range 100% ^{Cust} / Extended Range Min ^{Cust} / Extended Range Max ^{Cust} / Error Current ^{Cust} / Error Condition ^{Cust} / Measurement ^{Cust} / Range Min ^{Cust} / Range Max ^{Cust} / Polarity ^{Cust} / Limitation Min ^{Cust} / Limitation Max ^{Cust} / LFC Threshold ^{Cust} / LFC Hysteresis ^{Cust} / Time Constant ^{Cust} / Special Function ^{Cust} / Threshold Range Change ^{Opt, Cust} / Hysteresis Range Change ^{Opt, Cust} / <Information> / <Simulation>
Frequency Output A/B/D ^{Opt}	Pulse Shape ^{Opt, Cust} / Pulse Width ^{Opt, Cust} / 100% Pulse Rate ^{Opt, Cust} / Measurement ^{Cust} / Range Min ^{Cust} / Range Max ^{Cust} / Polarity ^{Cust} / Limitation Min ^{Cust} / Limitation Max ^{Cust} / LFC Threshold ^{Cust} / LFC Hysteresis ^{Cust} / Time Constant / Invert Signal ^{Cust} / Special Function ^{Opt, Cust} / Phase Shift ^{Opt, Cust} / <Information> / <Simulation>
Pulse Output A/B/D ^{Opt}	Pulse Shape ^{Opt, Cust} / Pulse Width ^{Opt, Cust} / Max. Pulse Rate ^{Opt, Cust} / Measurement ^{Cust} / Pulse Value Unit ^{Rd, Cust} / Value Per Pulse ^{Cust} / Polarity ^{Cust} / LFC Threshold ^{Cust} / LFC Hysteresis ^{Cust} / Time Constant / Invert Signal ^{Cust} / Special Function ^{Opt, Cust} / Phase Shift ^{Opt, Cust} / <Information> / <Simulation>

Status Output A/B/C/D ^{Opt}	Mode / Output A ^{Opt} / Output B ^{Opt} / Output C ^{Opt} / Output D ^{Opt} / Invert Signal / <Information> / <Simulation>
Limit Switch A/B/C/D ^{Opt}	Measurement / Threshold / Hysteresis / Polarity / Time Constant / Invert Signal / <Information> / <Simulation>
Control Input A/B ^{Opt}	Mode ^{Cust} / Invert Signal / <Information> / <Simulation>
Current Input A/B ^{Opt}	Range 0% Rd / Range 100% Rd / Extended Range Min / Extended Range Max / Measurement / Range Min ^{Cust} / Range Max ^{Cust} / Time Constant / <Information> / <Simulation>

I/O Counter

Counter 1/2/3 ^{Opt}	Counter Function ^{Cust} / Measurement ^{Opt} / <Select Measurement> ^{Opt} / LFC Threshold ^{Opt} / LFC Hysteresis ^{Opt} / Time Constant ^{Opt} / Preset Value ^{Opt} / <Reset Totalizer> ^{Opt} / <Set Counter> ^{Opt} / <Stop Counter> ^{Opt} / <Start Counter> ^{Opt} / <Information>
------------------------------	---------------------------------------------------------------------------------------------------------------------------------------------------------------------------------------------------------------------------------------------------------------------------------------------------------------------------------------------------------------------------------------------

I/O HART

I/O HART	PV is Rd / SV is / TV is / QV is / D/A Trim ^{Cust} / Apply Values ^{Cust}
----------	-------------------------------------------------------------------------------------------------------

Device

Device Info	Tag / C Number Rd / Device Serial No. Rd / Electronic Serial No. Rd / <SW.REV.MS> / <Electronic Revision ER> / <Circuit Board Info>
Display	Language / Default Display ^{Cust} / <SW.REV.UIS>

1./2. Meas. Page

1./2. Meas. Page	Function ^{Cust} / Measurement 1.line / Range Min ^{Cust} / Range Max ^{Cust} / Limitation Min / Limitation Max / LFC Threshold / LFC Hysteresis / Time Constant / Format 1st Line / Measurement 2nd Line ^{Opt, Cust} / Format 2nd Line ^{Opt, Cust} / Measurement 3rd Line ^{Opt, Cust} / Format 3rd Line ^{Opt, Cust}
Graphic Page	Select Range / Range Centre / Range +/- / Time Scale
Special Functions	<List Errors> / <Reset Errors> / <Warmstart> / <Read GDC Object> ^{Opt} / <Write GDC Object> ^{Opt}
Units	Meter Size Unit / Volume Flow Unit ^{Cust} / Corrected Volume Flow Unit ^{Rd, Opt} / Extended Corrected Vol. Flow Unit ^{Opt, Cust} / Enthalpy Flow Unit ^{Rd, Opt} / Extended Enthalpy Flow Unit ^{Opt, Cust} / Mass Flow Unit ^{Cust} / Specific Enthalpy Unit ^{Rd, Opt} / Extended Specific Enthalpy Unit ^{Opt, Cust} / Velocity Unit / Volume Unit ^{Cust} / Extended Volume Unit ^{Opt, Cust} / Corrected Volume Unit ^{Rd, Opt} / Extended Corrected Volume Unit ^{Opt, Cust} / Enthalpy Unit ^{Rd, Opt} / Extended Enthalpy Unit ^{Opt, Cust} / Mass Unit ^{Cust} / Density Unit Rd / Extended Density Unit ^{Opt, Cust} / Pressure Unit ^{Cust} / Temperature Unit ^{Cust}

HART

HART	HART Rd / Online Mode? ^{Loc} / <Prepare Parameter Download>
	Identification Polling address / Tag / Manufacturer Rd / Model Rd / Device ID Rd
	HART Revisions Universal revision Rd / Field device revision Rd / DD version Rd
	Device Info Descriptor / Message / Date / Final assembly number / Software revision / Hardware revision / Write Protect Rd
	Preambles Number of request preambles Rd / Number of response preambles

Service

Service Access	Access Level HART Rd / <Enable Service Access> / <Disable Service Access> ^{Opt}
----------------	-----------------------------------------------------------------------------------------------------

Signal Data^{Opt}

Signal Data	Transducer Type / Window Start / Window End / Pulse Form / Detection Method
	Detection Parameters Trigger Level / Trigger Margin / Envelope Margin / Peak Margin / Number Of Peaks / Envelope Ratio 1 / Envelope Ratio 2 / Envelope Ratio 3 / Envelope Ratio 4 / RelmaxLow / RelmaxHigh / MaxTrackFactor / MaxTrackOffset / MaxTrackLimit / MaxTrackHit / MaxTrackLim / XcorrActive / <Set FixedWinloc> / Fixed Gain / Xdetect / GainUnbalWarning / GainUnbalSigLost / XdetSNRLimit / XdetAverageNo / SNRLimSigLost / SNRLimWarning / Env. Shift monitor / Env. Ratio monitor
	Dead Time / <Impedance Test>
	Delay Test Mode / Act. Delay T1.1 ^{Opt} / Act. Delay T1.2 ^{Opt} / Act. Delay T2.1 ^{Opt} / Act. Delay T2.2 ^{Opt} / TD Trigger Level ^{Opt} / TD Trigger Margin ^{Opt} / TD Window Start ^{Opt} / TD Window End ^{Opt} / TD Dead Time ^{Opt} / Repetition Pings ^{Opt}
	Number Of Stacks / Number Of Bursts / Burst Period / Ping Time / Step-Up Voltage / <Set DSP Sets>

Path Data^{Opt}

Path Data	Number Of Paths / Velocity Of Sound / <Measure Path Lengths> / Path Length 1 / Path Length 2 / Path Length 3 / Weight 1 / Weight 2 / Weight 3 / Beam Angle / T Expansion Coeff. / P Expansion Coeff. / Transducer Compression
-----------	-------------------------------------------------------------------------------------------------------------------------------------------------------------------------------------------------------------------------------------

Service Calibration^{Opt}

Service Calibration	Front End Option Rd
	Zero Instrument Zero Offset Path 1 / Zero Offset Path 2 / Zero Offset Path 3
	Zero Converter Path 1 Rd / Path 2 Rd / Path 3 Rd

Service Info^{Opt}

Service Info	Detected C-No. Rd / C-Number (8th Position) Rd / Device Serial Number Rd / Serial Number Sensor Rd / V Number Sensor Rd
--------------	-----------------------------------------------------------------------------------------------------------------------------------------------------------------------------------

9.11.9 Offline Root Menu

Identification

Identification	Tag / Descriptor / Message / Date
Device	Manufacturer Rd / Device Type Rd / Device ID Rd / Final Assembly Number / C number Rd / Device Serial No. Rd / Electronic Serial No. Rd

Detailed Setup

Mapping of Variables

Mapping of Variables	PV is Rd / SV is / TV is / QV is
----------------------	---------------------------------------------

Process Input

Calibration	Meter Size / GK
Filter	Minimum Limit / Maximum Limit / Flow Direction / Time Constant / Threshold Low Flow Cutoff / Hysteresis Low Flow Cutoff
Plausibility	Error Limit / Counter Decrease / Counter Limit
Information	Serial Number Sensor / V Number Sensor
VoS monitor ^{Opt}	Monitor Velocity of Sound Monitor Settings Opt Matching Factor / Actual Ratio Measurement/Calibration / VoS Tolerance / Time Constant
Linearization	Linearization / Dynamic Viscosity ^{Opt}
General ^{Opt}	Adiabatic Index
P&T Correction ^{Opt}	P&T Correction / P&T Inputs ^{Opt} / Pipe Temperature ^{Opt} / Pipe Pressure ^{Opt} / Density ^{Opt}
Diagnosis Value	Diagnosis 1 / Diagnosis 2 / Diagnosis 3
HART	Sensor s/n / <Align HART Units> Actual Flow, Corrected Flow^{Opt}, Enthalpy Flow^{Opt}, Mass Flow, ... Unit / Format / Upper Sensor Limit / Lower Sensor Limit / Minimum Span

I/O

Hardware	Terminals A / Terminals B / Terminals C / Terminals D
Current Output A/B/C ^{Opt}	Range 0% ^{Cust} / Range 100% ^{Cust} / Extended Range Min ^{Cust} / Extended Range Max ^{Cust} / Error Current ^{Cust} / Error Condition ^{Cust} / Measurement ^{Cust} / Range Min ^{Cust} / Range Max ^{Cust} / Polarity ^{Cust} / Limitation Min ^{Cust} / Limitation Max ^{Cust} / LFC Threshold ^{Cust} / LFC Hysteresis ^{Cust} / Time Constant ^{Cust} / Special Function ^{Cust} / Threshold Range Change ^{Opt, Cust} / Hysteresis Range Change ^{Opt, Cust}
Frequency Output A/B/D ^{Opt}	Pulse Shape ^{Opt, Cust} / Pulse Width ^{Opt, Cust} / 100% Pulse Rate ^{Opt, Cust} / Measurement ^{Cust} / Range Min ^{Cust} / Range Max ^{Cust} / Polarity ^{Cust} / Limitation Min ^{Cust} / Limitation Max ^{Cust} / LFC Threshold ^{Cust} / LFC Hysteresis ^{Cust} / Time Constant / Invert Signal ^{Cust} / Special Function ^{Opt, Cust} / Phase Shift ^{Opt, Cust}
Pulse Output A/B/D ^{Opt}	Pulse Shape ^{Opt, Cust} / Pulse Width ^{Opt, Cust} / Max. Pulse Rate ^{Opt, Cust} / Measurement ^{Cust} / Pulse Value Unit ^{Rd, Cust} / Value Per Pulse ^{Cust} / Polarity ^{Cust} / LFC Threshold ^{Cust} / LFC Hysteresis ^{Cust} / Time Constant / Invert Signal ^{Cust} / Special Function ^{Opt, Cust} / Phase Shift ^{Opt, Cust}
Status Output A/B/C/D ^{Opt}	Mode / Output A ^{Opt} / Output B ^{Opt} / Output C ^{Opt} / Output D ^{Opt} / Invert Signal

Limit Switch A/B/C/D ^{Opt}	Measurement / Threshold / Hysteresis / Polarity / Time Constant / Invert Signal
Control Input A/B ^{Opt}	Mode ^{Cust} / Invert Signal
Current Input A/B ^{Opt}	Range 0% Rd / Range 100% Rd / Extended Range Min / Extended Range Max / Measurement / Range Min ^{Cust} / Range Max ^{Cust} / Time Constant
Counter 1/2/3 ^{Opt}	Counter Function ^{Cust} / Measurement ^{Opt} / LFC Threshold ^{Opt} / LFC Hysteresis ^{Opt} / Time Constant ^{Opt} / Preset Value ^{Opt}

I/O HART

I/O HART	PV is Rd / SV is / TV is / QV is
----------	---------------------------------------------

Device

Device Info	Tag / C Number Rd / Device Serial No. Rd / Electronic Serial No. Rd
Display	Language / Default Display ^{Cust} / <SW.REV.UIS>
1./2. Meas. Page	Function ^{Cust} / Measurement 1.line / Range Min ^{Cust} / Range Max ^{Cust} / Limitation Min / Limitation Max / LFC Threshold / LFC Hysteresis / Time Constant / Format 1st Line / Measurement 2nd Line ^{Opt, Cust} / Format 2nd Line ^{Opt, Cust} / Measurement 3rd Line ^{Opt, Cust} / Format 3rd Line ^{Opt, Cust}
Graphic Page	Select Range / Range Centre / Range +/- / Time Scale
Units	Meter Size Unit / Volume Flow Unit ^{Cust} / Corrected Volume Flow Unit ^{Rd, Opt} / Extended Corrected Vol. Flow Unit ^{Opt, Cust} / Enthalpy Flow Unit ^{Rd, Opt} / Extended Enthalpy Flow Unit ^{Opt, Cust} / Mass Flow Unit ^{Cust} / Specific Enthalpy Unit ^{Rd, Opt} / Extended Specific Enthalpy Unit ^{Opt, Cust} / Velocity Unit / Volume Unit ^{Cust} / Extended Volume Unit ^{Opt, Cust} / Corrected Volume Unit ^{Rd, Opt} / Extended Corrected Volume Unit ^{Opt, Cust} / Enthalpy Unit ^{Rd, Opt} / Extended Enthalpy Unit ^{Opt, Cust} / Mass Unit ^{Cust} / Density Unit Rd / Extended Density Unit ^{Opt, Cust} / Pressure Unit ^{Cust} / Temperature Unit ^{Cust}

HART

HART	HART Rd / Online Mode? ^{Loc}
	Identification Polling address / Tag / Manufacturer Rd / Model Rd / Device ID Rd
	HART Revisions Universal revision Rd / Field device revision Rd / DD-Version Rd
	Device Info Descriptor / Message / Date / Final assembly number / Software revision / Hardware revision / Write Protect Rd
	Preambles Number of request preambles Rd / Number of response preambles

Service

Service Access	Access Level HART Rd
Signal Data	Transducer Type / Window Start / Window End / Pulse Form / Detection Method
	Detection Parameters Trigger Level / Trigger Margin / Envelope Margin / Peak Margin / Number Of Peaks / Envelope Ratio 1 / Envelope Ratio 2 / Envelope Ratio 3 / Envelope Ratio 4 / RelmaxLow / RelmaxHigh / MaxTrackFactor / MaxTrackOffset / MaxTrackLimit / MaxTrackHit / MaxTrackLim / XcorrActive / <Set FixedWinloc> / Fixed Gain / Xdetect / GainUnbalWarning / GainUnbalSigLost / XdetSNRLimit / XdetAverageNo / SNRLimSigLost / SNRLimWarning / Env. Shift monitor / Env. Ratio monitor
	Dead Time / <Impedance Test>
	Delay Test Mode / TD Trigger Level ^{Opt} / TD Trigger Margin ^{Opt} / TD Window Start ^{Opt} / TD Window End ^{Opt} / TD Dead Time ^{Opt} / Repetition Pings ^{Opt}
	Number Of Stacks / Number Of Bursts / Burst Period / Ping Time / Step-Up Voltage
Path Data	Number Of Paths / Velocity Of Sound / Path Length 1 / Path Length 2 / Path Length 3 / Weight 1 / Weight 2 / Weight 3 / Beam Angle / T Expansion Coeff. / P Expansion Coeff. / Transducer Compression
Service Calibration	Front End Option Rd
	Zero Instrument Zero Offset Path 1 / Zero Offset Path 2 / Zero Offset Path 3
	Zero Converter Path 1 Rd / Path 2 Rd / Path 3 Rd
Service Info	Detected C-No. Rd / C-Number (8th Position) Rd / Device Serial Number Rd / Serial Number Sensor Rd / V Number Sensor Rd



KROHNE product overview

- Electromagnetic flowmeters
- Variable area flowmeters
- Ultrasonic flowmeters
- Mass flowmeters
- Vortex flowmeters
- Flow controllers
- Level meters
- Temperature assemblies
- Pressure transmitters
- Analysis products
- Products and systems for the oil & gas industry
- Measuring systems for the marine industry

Head Office KROHNE Messtechnik GmbH
Ludwig-Krohne-Str. 5
47058 Duisburg (Germany)
Tel.: +49 203 301 0
Fax: +49 203 301 103 89
info@krohne.com

The current list of all KROHNE contacts and addresses can be found at:
www.krohne.com

KROHNE