



## **OPTISOUND 3030 C** Handbook

Ultrasonic Level Transmitter

Foundation Fieldbus



**KROHNE**

# Contents

<b>1</b>	<b>About this document</b> .....	<b>4</b>
1.1	Function .....	4
1.2	Target group .....	4
1.3	Symbols used.....	4
<b>2</b>	<b>For your safety</b> .....	<b>5</b>
2.1	Authorised personnel .....	5
2.2	Appropriate use.....	5
2.3	Warning about incorrect use.....	5
2.4	General safety instructions .....	5
2.5	EU conformity.....	5
2.6	Fulfillment of NAMUR recommendations .....	6
2.7	Installation and operation in the USA and Canada .....	6
<b>3</b>	<b>Product description</b> .....	<b>7</b>
3.1	Configuration.....	7
3.2	Principle of operation.....	8
3.3	Packaging, transport and storage.....	8
<b>4</b>	<b>Mounting</b> .....	<b>10</b>
4.1	General instructions .....	10
4.2	Mounting instructions .....	11
<b>5</b>	<b>Connecting to power supply</b> .....	<b>18</b>
5.1	Preparing the connection .....	18
5.2	Connection procedure.....	19
5.3	Wiring plan, single chamber housing.....	20
5.4	Wiring plan, double chamber housing .....	22
5.5	Switch-on phase.....	23
<b>6</b>	<b>Set up with the display and adjustment module</b> .....	<b>24</b>
6.1	Insert display and adjustment module .....	24
6.2	Adjustment system .....	25
6.3	Setup steps .....	26
6.4	Menu schematic.....	35
6.5	Saving the parameterisation data.....	37
<b>7</b>	<b>Maintenance and fault rectification</b> .....	<b>38</b>
7.1	Maintenance .....	38
7.2	Rectify faults.....	38
7.3	Exchanging the electronics module.....	39
7.4	How to proceed if a repair is necessary.....	39
<b>8</b>	<b>Dismount</b> .....	<b>40</b>
8.1	Dismounting steps.....	40
8.2	Disposal .....	40
<b>9</b>	<b>Supplement</b> .....	<b>41</b>
9.1	Technical data .....	41
9.2	Device communication Foundation Fieldbus.....	44
9.3	Dimensions .....	48
9.4	Trademark .....	50



# 1 About this document

## 1.1 Function

This instruction provides all the information you need for mounting, connection and setup as well as important instructions for maintenance, fault rectification, the exchange of parts and the safety of the user. Please read this information before putting the instrument into operation and keep this manual accessible in the immediate vicinity of the device.

## 1.2 Target group

This operating instructions manual is directed to trained personnel. The contents of this manual must be made available to the qualified personnel and implemented.

## 1.3 Symbols used



**Information, note, tip:** This symbol indicates helpful additional information and tips for successful work.



**Note:** This symbol indicates notes to prevent failures, malfunctions, damage to devices or plants.



**Caution:** Non-observance of the information marked with this symbol may result in personal injury.



**Warning:** Non-observance of the information marked with this symbol may result in serious or fatal personal injury.



**Danger:** Non-observance of the information marked with this symbol results in serious or fatal personal injury.



### Ex applications

This symbol indicates special instructions for Ex applications.



### List

The dot set in front indicates a list with no implied sequence.



### Sequence of actions

Numbers set in front indicate successive steps in a procedure.



### Disposal

This symbol indicates special instructions for disposal.

## 2 For your safety

### 2.1 Authorised personnel

All operations described in this documentation must be carried out only by trained, qualified personnel authorised by the plant operator. During work on and with the device, the required personal protective equipment must always be worn.

### 2.2 Appropriate use

OPTISOUND 3030 C is a sensor for continuous level measurement. You can find detailed information about the area of application in chapter " *Product description*".

Operational reliability is ensured only if the instrument is properly used according to the specifications in the operating instructions manual as well as possible supplementary instructions.

### 2.3 Warning about incorrect use

Inappropriate or incorrect use of this product can give rise to application-specific hazards, e.g. vessel overflow through incorrect mounting or adjustment. Damage to property and persons or environmental contamination can result. Also, the protective characteristics of the instrument can be impaired.

### 2.4 General safety instructions

This is a state-of-the-art instrument complying with all prevailing regulations and directives. The instrument must only be operated in a technically flawless and reliable condition. The operator is responsible for the trouble-free operation of the instrument. When measuring aggressive or corrosive media that can cause a dangerous situation if the instrument malfunctions, the operator has to implement suitable measures to make sure the instrument is functioning properly.

The safety instructions in this operating instructions manual, the national installation standards as well as the valid safety regulations and accident prevention rules must be observed by the user.

For safety and warranty reasons, any invasive work on the device beyond that described in the operating instructions manual may be carried out only by personnel authorised by the manufacturer. Arbitrary conversions or modifications are explicitly forbidden. For safety reasons, only the accessory specified by the manufacturer must be used.

To avoid any danger, the safety approval markings and safety tips on the device must also be observed.

### 2.5 EU conformity

The device fulfils the legal requirements of the applicable EU directives. By affixing the CE marking, we confirm the conformity of the instrument with these directives.

The EU conformity declaration can be found on our homepage.

## 2.6 Fulfillment of NAMUR recommendations

NAMUR is the automation technology user association in the process industry in Germany. The published NAMUR recommendations are accepted as the standard in field instrumentation.

The device fulfils the requirements of the following NAMUR recommendations:

- NE 21: 2012 – Electromagnetic compatibility of equipment
- NE 43 – Signal level for fault information from measuring transducers
- NE 53 – Compatibility of field devices and display/adjustment components

For further information see [www.namur.de](http://www.namur.de).

## 2.7 Installation and operation in the USA and Canada

This information is only valid for USA and Canada. Hence the following text is only available in the English language.

Installations in the US shall comply with the relevant requirements of the National Electrical Code (ANSI/NFPA 70).

Installations in Canada shall comply with the relevant requirements of the Canadian Electrical Code.

## 3 Product description

### 3.1 Configuration

#### Scope of delivery

The scope of delivery encompasses:

- OPTISOUND 3030 C ultrasonic sensor
- Optionally mounting strap or compression flange
- Documentation
  - This operating instructions manual
  - Ex-specific safety instructions (with Ex versions)
  - Operating instructions " *Display and adjustment module*" (optional)
  - If necessary, further certificates



#### Information:

Optional instrument features are also described in this operating instructions manual. The respective scope of delivery results from the order specification.

#### Constituent parts

The OPTISOUND 3030 C consists of the components:

- Process fitting with transducer
- Housing with electronics
- Housing lid with integrated display and adjustment module (optional)

The components are available in different versions.

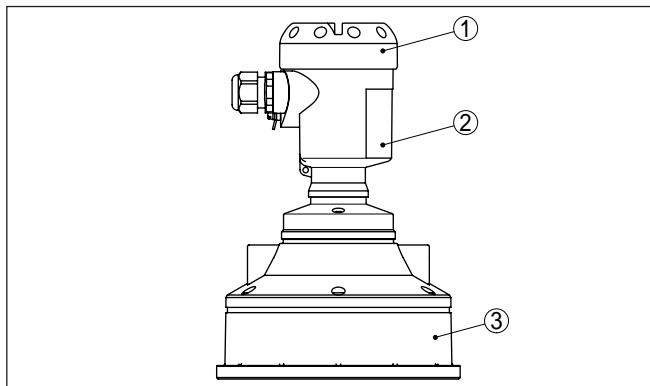

Fig. 1: OPTISOUND 3030 C, plastic housing

- 1 Housing lid with integrated display and adjustment module (optional)
- 2 Housing with electronics
- 3 Process fitting with transducer

#### Type label

The type label contains the most important data for identification and use of the instrument:

- Instrument type
- Article and serial number device
- Article numbers, documentation

- Technical data: For example approvals, process temperature, process fitting/material, signal output, voltage supply, protection

### 3.2 Principle of operation

#### Application area

OPTISOUND 3030 C is an ultrasonic sensor for continuous level measurement. It is suitable for liquids and solids in practically all industries.

#### Functional principle

The transducer of the ultrasonic sensor transmits short ultrasonic pulses to the measured product. These pulses are reflected by medium surface and received back by the transducer as echoes. The running time of the ultrasonic pulses from emission to reception is proportional to the distance and hence the level. The determined level is converted into an appropriate output signal and outputted as measured value.

#### Power supply and bus communication

Power is supplied via the H1 Fieldbus. A two-wire cable according to Fieldbus specification serves as carrier of both power and digital data for multiple sensors. This cable can be operated in two versions:

- via an H1 interface card in the control system and additional power supply
- via a Linking device with HSE (High speed Ethernet) and additional power supply according to IEC 61158-2

#### DD/CFF

The DD (Device Descriptions) and CFF (capability files) necessary for planning and configuration of your FF (Foundation Fieldbus) communication network are available in the download area.

The backlight of the display and adjustment module is powered by the sensor. Prerequisite is a certain level of operating voltage.

The data for power supply are specified in chapter " *Technical data*".

### 3.3 Packaging, transport and storage

#### Packaging

Your instrument was protected by packaging during transport. Its capacity to handle normal loads during transport is assured by a test based on ISO 4180.

The packaging of standard instruments consists of environment-friendly, recyclable cardboard. For special versions, PE foam or PE foil is also used. Dispose of the packaging material via specialised recycling companies.

#### Transport

Transport must be carried out in due consideration of the notes on the transport packaging. Nonobservance of these instructions can cause damage to the device.

#### Transport inspection

The delivery must be checked for completeness and possible transit damage immediately at receipt. Ascertained transit damage or concealed defects must be appropriately dealt with.



**Storage**

Up to the time of installation, the packages must be left closed and stored according to the orientation and storage markings on the outside.

Unless otherwise indicated, the packages must be stored only under the following conditions:

- Not in the open
- Dry and dust free
- Not exposed to corrosive media
- Protected against solar radiation
- Avoiding mechanical shock and vibration

**Storage and transport temperature**

- Storage and transport temperature see chapter " *Supplement - Technical data - Ambient conditions*"
- Relative humidity 20 ... 85 %

**Lifting and carrying**

With instrument weights of more than 18 kg (39.68 lbs) suitable and approved equipment must be used for lifting and carrying.

## 4 Mounting

### 4.1 General instructions

#### Installation position

Select an installation position you can easily reach for mounting and connecting as well as later retrofitting of a display and adjustment module. The housing can be rotated by 330° without the use of any tools. You can also install the display and adjustment module in four different positions (each displaced by 90°).

#### Moisture

Use the recommended cables (see chapter " *Connecting to power supply* ") and tighten the cable gland.

You can give your instrument additional protection against moisture penetration by leading the connection cable downward in front of the cable gland. Rain and condensation water can thus drain off. This applies mainly to outdoor mounting as well as installation in areas where high humidity is expected (e.g. through cleaning processes) or on cooled or heated vessels.

To maintain the housing protection, make sure that the housing lid is closed during operation and locked, if necessary.

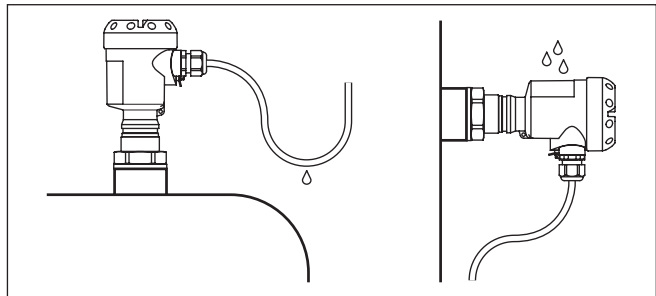

Fig. 2: Measures against moisture ingress

#### Cable entries - NPT thread Cable glands

##### Metric threads

In the case of instrument housings with metric thread, the cable glands are screwed in at the factory. They are sealed with plastic plugs as transport protection.

You have to remove these plugs before electrical connection.

##### NPT thread

In the case of instrument housings with self-sealing NPT threads, it is not possible to have the cable entries screwed in at the factory. The free openings for the cable glands are therefore covered with red dust protection caps as transport protection.

Prior to setup you have to replace these protective caps with approved cable glands or close the openings with suitable blind plugs.

#### Measuring range

The reference plane for the measuring range is the lower edge of the transducer.

Make sure that a minimum distance from the reference plane - the so-called blocking distance, in which measurement is not possible

- is maintained. The exact value of the blocking distance is stated in chapter " *Technical data*".

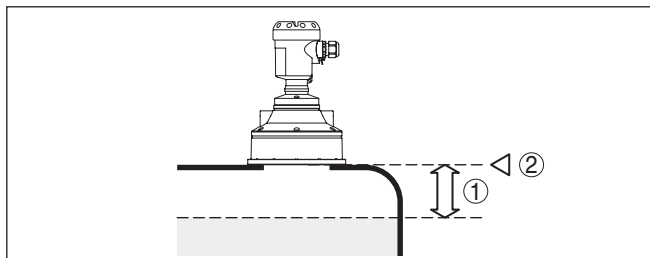

Fig. 3: Minimum distance to the max. level

- 1 blocking distance
- 2 Reference plane



#### Information:

If the medium reaches the transducer, buildup can form on it and cause faulty measurements later on.

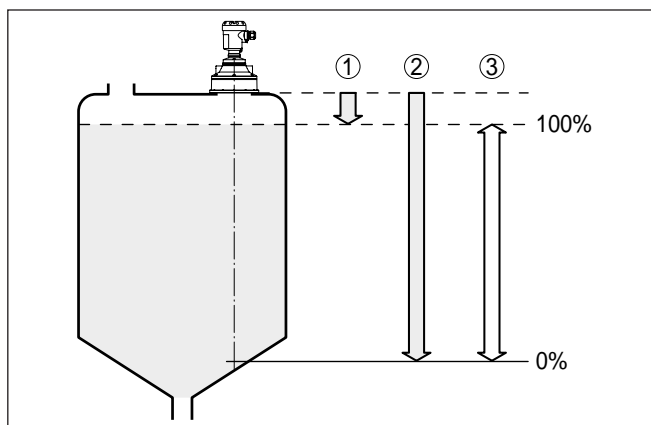

Fig. 4: Measuring range (operating range) and max. measuring distance

- 1 full
- 2 empty (max. measuring distance)
- 3 Measuring range

#### Pressure/Vacuum

Gauge pressure in the vessel does not influence OPTISOUND 3030 C. Low pressure or vacuum does, however, damp the ultrasonic pulses. This influences the measuring result, particularly if the level is very low. With pressures under -0.2 bar (-20 kPa) you should use a different measuring principle, e.g. radar or guided radar (TDR).

## 4.2 Mounting instructions

When mounting the OPTISOUND 3030 C, keep a distance of at least 200 mm (7.874 in) to the vessel wall. If the sensor is installed in the center of dished or round vessel tops, multiple echoes can arise.

#### Installation position

These can, however, be suppressed by an appropriate adjustment (see chapter "Setup").

If this distance cannot be maintained, a false signal suppression should be carried out during setup. This applies particularly if buildup on the vessel wall is expected. In such cases, we recommend repeating the false signal suppression at a later date with existing buildup.

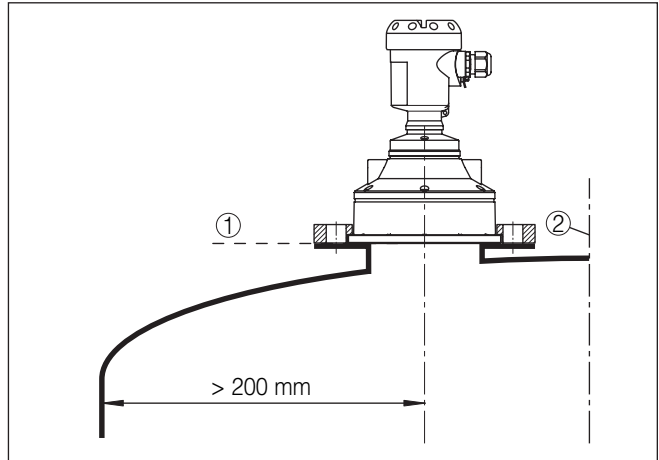

Fig. 5: Mounting on round vessel tops

- 1 Reference plane
- 2 Vessel center or symmetry axis

In vessels with conical bottom it can be advantageous to mount the sensor in the centre of the vessel, as measurement is then possible down to the bottom.

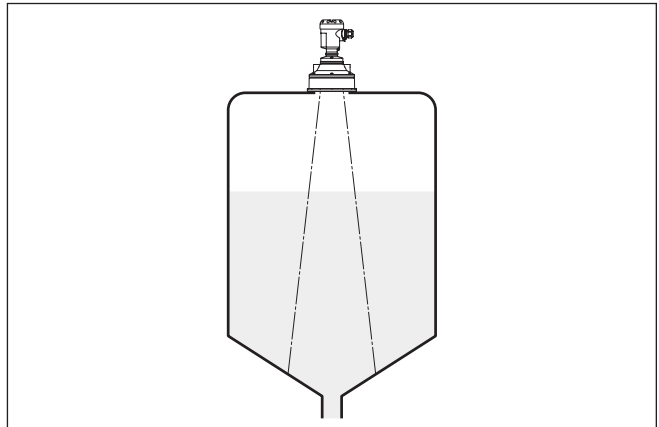

Fig. 6: Vessel with conical bottom

### Nozzle

Preferably the transducer should be mounted flush to the vessel top.

If the reflective properties of the medium are good, you can mount OPTISOUND 3030 C on a socket piece. You will find recommended values for socket heights in the following illustration. The socket end should be smooth and burr-free, if possible also rounded. Carry out a false signal suppression.

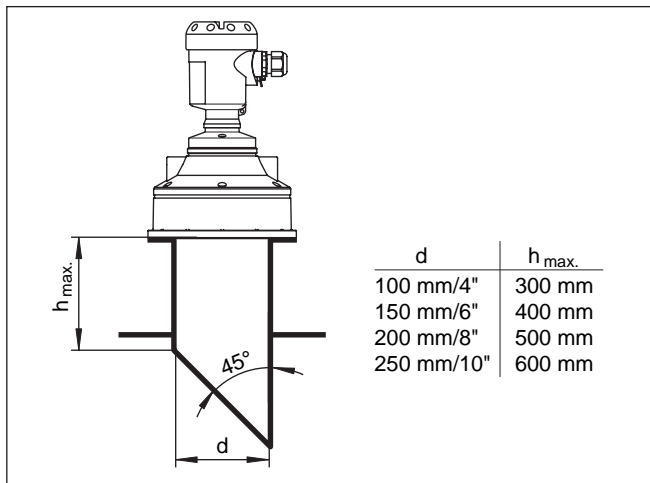

Fig. 7: Deviating socket dimensions

### Sensor orientation

In liquids, direct the sensor as perpendicular as possible to the medium surface to achieve optimum measurement results.

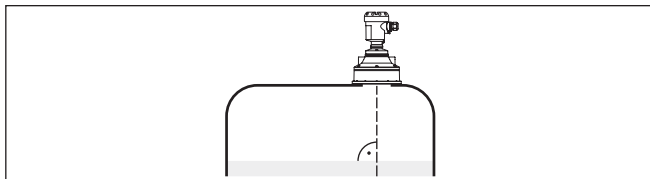

Fig. 8: Alignment in liquids

To optimally align the sensor to solid products, a swivelling holder (mounting strap) can be implemented.

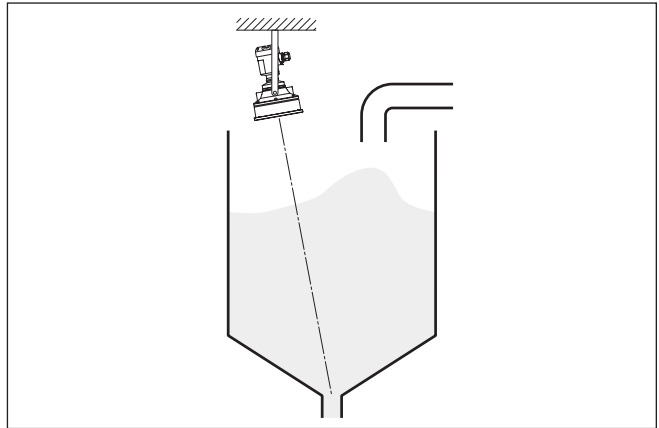

Fig. 9: Orientation in bulk solids

To reduce the min. distance to the medium, you can also mount OP-TISOUND 3030 C with a beam deflector. By doing this, it is possible to fill the vessel nearly to maximum. Such an arrangement is suitable primarily for open vessels such as e.g. overflow basins.

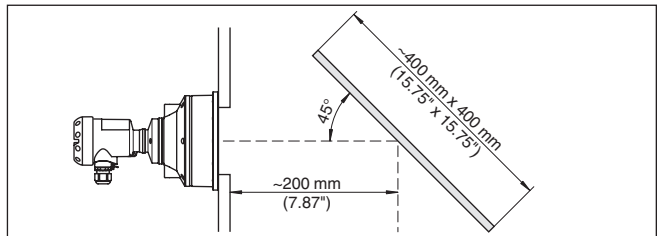

Fig. 10: Beam deflector

## Vessel installations

The ultrasonic sensor should be installed at a location where no installations cross the ultrasonic beam.

Vessel installations such as for example, ladders, limit switches, heating spirals, struts etc. can cause false echoes that interfere with the useful echo. Make sure when planning your measuring site that the ultrasonic signals have a "clear view" to the measured product.

In case of existing vessel installations, a false signal suppression should be carried out during setup.

If large vessel installations such as struts or supports cause false echoes, these can be attenuated through supplementary measures. Small, inclined sheet metal or plastic baffles above the installations scatter the ultrasonic signals and avoid direct false echoes.

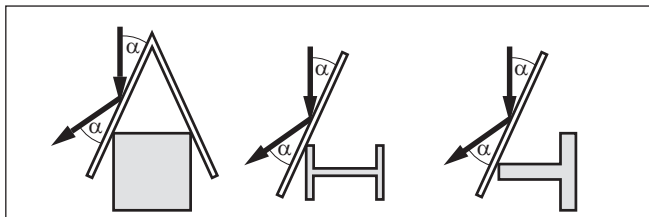

Fig. 11: Cover flat, large-area profiles with deflectors

### Agitators

If there are agitators in the vessel, a false signal suppression should be carried out with the agitators in motion. This ensures that the interfering reflections from the agitators are saved with the blades in different positions.

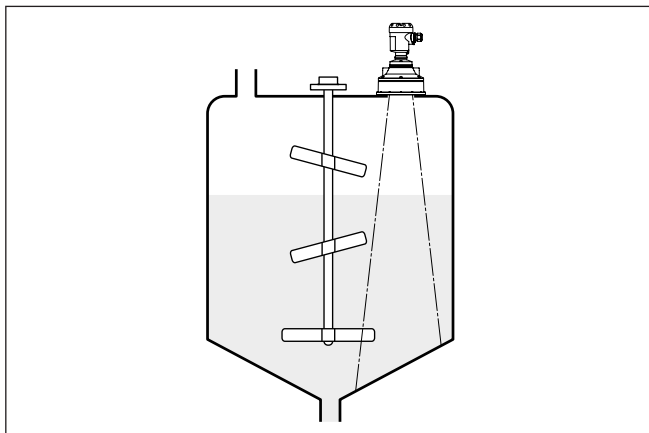

Fig. 12: Agitators

### Inflowing medium

Do not mount the instruments in or above the filling stream. Make sure that you detect the medium surface, not the inflowing product.

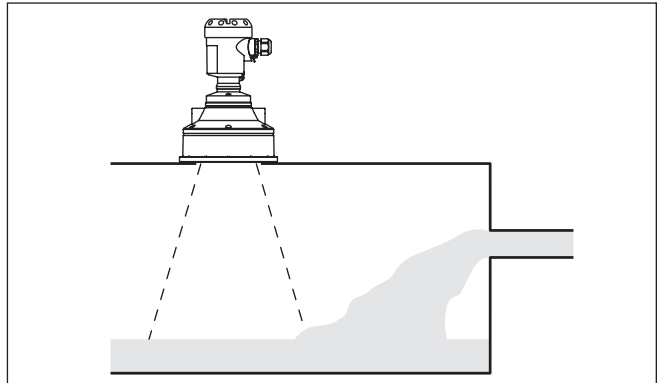

Fig. 13: Inflowing liquid

### Foam

Through the action of filling, stirring and other processes in the vessel, dense foams which considerably damp the emitted signals may form on the medium surface.

If foams are causing measurement errors, the sensor should be used in a standpipe or, alternatively, the more suitable guided radar sensors (TDR) should be used.

Guided wave radar is unaffected by foam generation and is particularly suitable for such applications.

### Air turbulences

If there are strong air currents in the vessel, e.g. due to strong winds in outdoor installations or air turbulence, e.g. by cyclone extraction you should mount OPTISOUND 3030 C in a standpipe or use a different measuring principle, e.g. radar or guided radar (TDR).

### Standpipe measurement

By using a standpipe (surge or bypass tube), the influence of vessel installations, foam generation and turbulence is excluded.

Standpipes must extend all the way down to the requested min. level, as measurement is only possible within the tube.



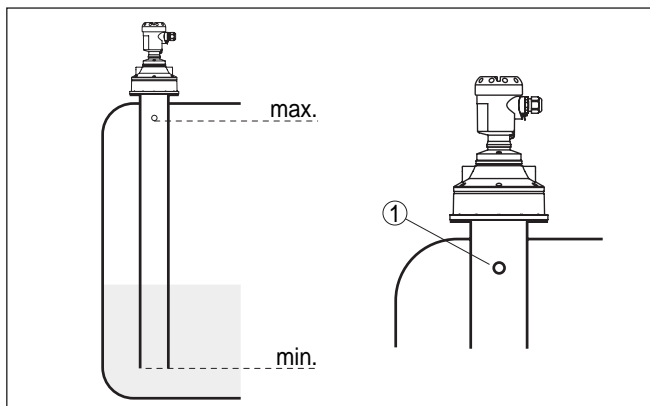

Fig. 14: Standpipe in the tank

1 Vent hole  $\varnothing 5 \dots 10 \text{ mm}$

OPTISOUND 3030 C can be used from tube diameters of 100 mm.  
Avoid large gaps and thick welding joints when connecting the tubes.  
Generally carry out a false signal suppression.

Measurement in a standpipe is not recommended for adhesive products.

## 5 Connecting to power supply

### 5.1 Preparing the connection

#### Safety instructions

Always keep in mind the following safety instructions:



#### Warning:

Connect only in the complete absence of line voltage.

- The electrical connection must only be carried out by trained, qualified personnel authorised by the plant operator.
- If overvoltage surges are expected, overvoltage arresters should be installed.

#### Voltage supply

The instrument requires a operating voltage of 9 ... 32 V DC. Operating voltage and the digital bus signal are carried on the same two-wire connection cable. Power is supplied via the H1 power supply.

#### Connection cable

Connection is carried out with shielded cable according to Fieldbus specification.

Make sure that the cable used has the required temperature resistance and fire safety for max. occurring ambient temperature

Use cable with round cross section for instruments with housing and cable gland. To ensure the seal effect of the cable gland (IP protection rating), find out which cable outer diameter the cable gland is suitable for.

Use a cable gland fitting the cable diameter.

Make sure that the entire installation is carried out according to the Fieldbus specification. In particular, make sure that the bus is terminated with suitable terminating resistors.

#### Cable glands

##### Metric threads

In the case of instrument housings with metric thread, the cable glands are screwed in at the factory. They are sealed with plastic plugs as transport protection.



#### Note:

You have to remove these plugs before electrical connection.

##### NPT thread

In the case of instrument housings with self-sealing NPT threads, it is not possible to have the cable entries screwed in at the factory. The free openings for the cable glands are therefore covered with red dust protection caps as transport protection.



#### Note:

Prior to setup you have to replace these protective caps with approved cable glands or close the openings with suitable blind plugs.

On plastic housings, the NPT cable gland or the Conduit steel tube must be screwed into the threaded insert without grease.

Max. torque for all housings, see chapter " *Technical data*".

### Cable screening and grounding

In systems with potential equalisation, connect the cable screening directly to ground potential at the power supply unit, in the connection box and at the sensor. The screen in the sensor must be connected directly to the internal ground terminal. The ground terminal outside on the housing must be connected to the potential equalisation (low impedance).

In systems without potential equalisation, connect the cable screen directly to ground potential at the power supply unit and at the sensor. In the connection box or T-distributor, the screening of the short stub to the sensor must not be connected to ground potential or to another cable screen. The cable screens to the power supply unit and to the next distributor must be connected to each other and also connected to ground potential via a ceramic capacitor (e.g. 1 nF, 1500 V). The low frequency potential equalisation currents are thus suppressed, but the protective effect against high frequency interference signals remains.



The total capacitance of the cable and of all capacitors must not exceed 10 nF in Ex applications.



Take note of the corresponding installation regulations for Ex applications. In particular, make sure that no potential equalisation currents flow over the cable screen. In case of grounding on both sides this can be achieved by the use of a capacitor or a separate potential equalisation.

## 5.2 Connection procedure

Proceed as follows:

1. Unscrew the housing lid
2. If a display and adjustment module is installed, remove it by turning it to the left
3. Loosen compression nut of the cable gland and remove blind plug
4. Remove approx. 10 cm (4 in) of the cable mantle, strip approx. 1 cm (0.4 in) of insulation from the ends of the individual wires
5. Insert the cable into the sensor through the cable entry
6. Lift the opening levers of the terminals with a screwdriver (see following illustration)
7. Insert the wire ends into the open terminals according to the wiring plan

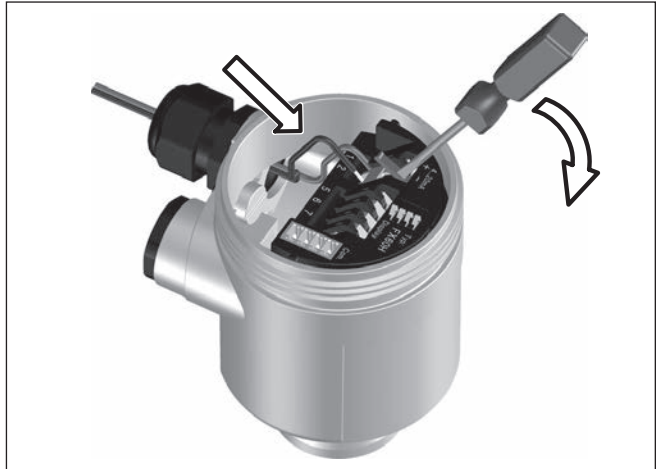

Fig. 15: Connection steps 6 and 7

8. Press down the opening levers of the terminals, you will hear the terminal spring closing
  9. Check the hold of the wires in the terminals by lightly pulling on them
  10. Connect the shielding to the internal ground terminal, connect the external ground terminal to potential equalisation
  11. Tighten the compression nut of the cable entry gland. The seal ring must completely encircle the cable
  12. Screw the housing lid back on
- The electrical connection is finished.

### 5.3 Wiring plan, single chamber housing

#### Housing overview

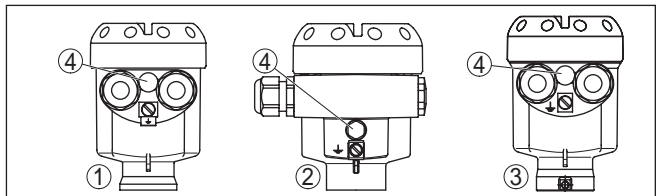

Fig. 16: Material versions, single chamber housing

- 1 Plastic
- 2 Aluminium
- 3 Stainless steel
- 4 Filter element for air pressure compensation

**Electronics and connection compartment**

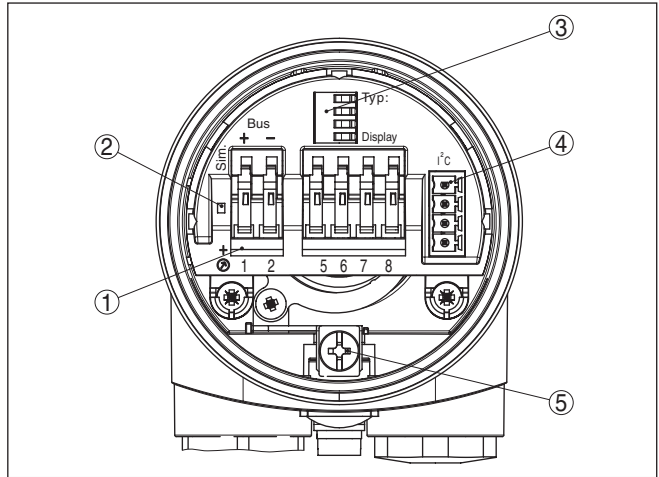

Fig. 17: Electronics and connection compartment - single chamber housing

- 1 Spring-loaded terminals for Foundation Fieldbus connection
- 2 Simulation switch ("on" = simulation mode)
- 3 Spring contacts for display and adjustment module
- 4 Interface for service
- 5 Ground terminal for connection of the cable screening

**Wiring plan**

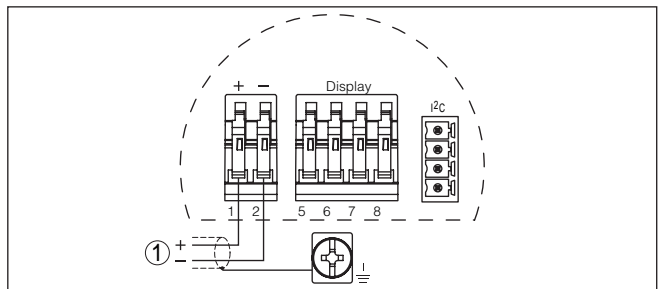

Fig. 18: Wiring plan - single chamber housing

- 1 Voltage supply, signal output

## 5.4 Wiring plan, double chamber housing

### Housing overview

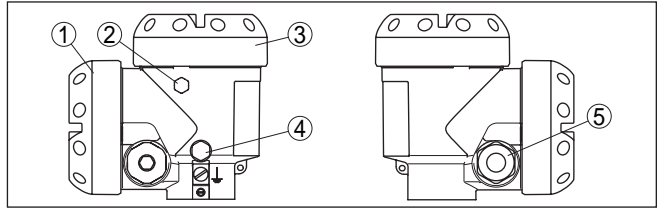

Fig. 19: Double chamber housing

- 1 Housing cover - connection compartment
- 2 Blind plug
- 3 Housing cover - electronics compartment
- 4 Filter element for air pressure compensation
- 5 Cable gland

### Electronics compartment

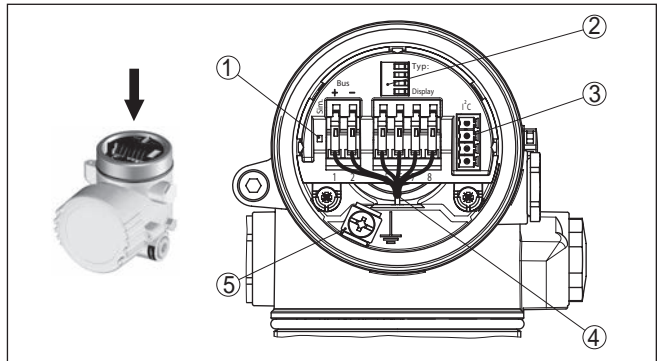

Fig. 20: Electronics compartment - double chamber housing

- 1 Simulation switch ("on" = simulation mode)
- 2 Spring contacts for display and adjustment module
- 3 Interface for service
- 4 Internal connection cable to the connection compartment
- 5 Ground terminal for connection of the cable screening

## Connection compartment

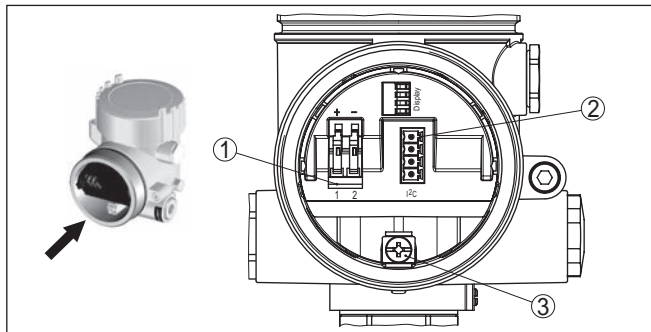

Fig. 21: Connection compartment, double chamber housing

- 1 Spring-loaded terminals for voltage supply
- 2 Plug connector for service interface
- 3 Ground terminal for connection of the cable screening

## Wiring plan

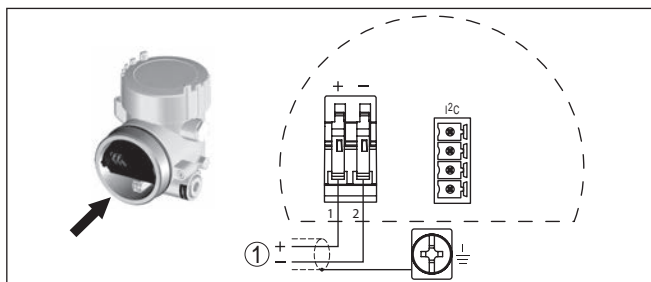

Fig. 22: Wiring plan - double chamber housing

- 1 Voltage supply, signal output

## 5.5 Switch-on phase

### Switch-on phase

After OPTISOUND 3030 C is connected to voltage supply or after voltage recurrence, the instrument carries out a self-check for approx. 30 seconds. The following steps are carried out:

- Internal check of the electronics
- Indication of the instrument type, the firmware as well as the sensor TAGs (sensor designation)
- Status byte goes briefly to fault value

Then the current measured value will be displayed and the corresponding digital output signal will be output to the cable. <sup>1)</sup>

<sup>1)</sup> The values correspond to the actual measured level as well as to the settings already carried out, e.g. default setting.

## 6 Set up with the display and adjustment module

### Mount/dismount display and adjustment module

### 6.1 Insert display and adjustment module

The display and adjustment module can be inserted into the sensor and removed again at any time. It is not necessary to interrupt the voltage supply.

Proceed as follows:

1. Unscrew the housing lid
2. Place the display and adjustment module in the desired position on the electronics (four positions in 90° offset can be selected) and turn to the right until it clicks into place.
3. Screw housing lid with inspection window tightly back on

Disassembly is carried out in reverse order.

The display and adjustment module is powered by the sensor, an additional connection is not necessary.



Fig. 23: Insert display and adjustment module in the single chamber housing



#### Note:

If you intend to retrofit the instrument with a display and adjustment module for continuous measured value indication, a higher lid with an inspection glass is required.



## 6.2 Adjustment system

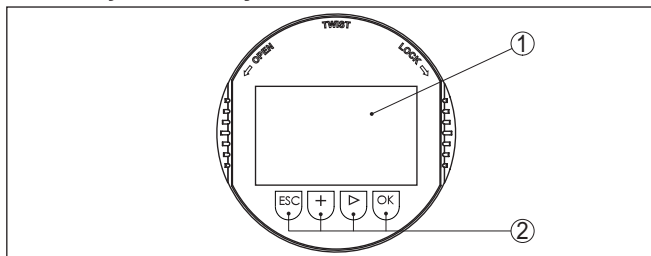

Fig. 24: Display and adjustment elements

- 1 LC display
- 2 Indication of the menu item number
- 3 Adjustment keys

### Key functions

- **[OK]** key:
  - Move to the menu overview
  - Confirm selected menu
  - Edit parameter
  - Save value
- **[->]** key to select:
  - Menu change
  - Select list entry
  - Select editing position
- **[+]** key:
  - Change value of the parameter
- **[ESC]** key:
  - Interrupt input
  - Jump to next higher menu

### Adjustment system

The instrument is operated via the four keys of the display and adjustment module. The individual menu items are shown on the LC display. You can find the function of the individual keys in the previous illustration.

### Time functions

When the **[+]** and **[->]** keys are pressed quickly, the edited value, or the cursor, changes one value or position at a time. If the key is pressed longer than 1 s, the value or position changes continuously.

When the **[OK]** and **[ESC]** keys are pressed simultaneously for more than 5 s, the display returns to the main menu. The menu language is then switched over to "English".

Approx. 60 minutes after the last pressing of a key, an automatic reset to measured value indication is triggered. Any values not confirmed with **[OK]** will not be saved.

### 6.3 Setup steps

#### Parameter adjustment

The sensor measures the distance from the sensor to the medium surface. For indication of the real level, an allocation of the measured distance to the percentage height must be carried out.

The actual level is then calculated on the basis of these entered values. At the same time, the operating range of the sensor is limited from maximum range to the requested range.

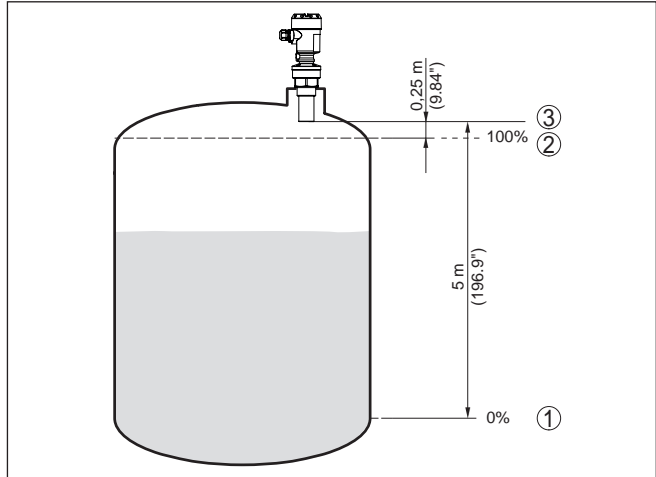

Fig. 25: Parameterisation example, Min./max. adjustment

- 1 Min. level = max. distance (depending on the sensor)
- 2 Max. level = min. distance (final value of the blocking distance, depending on the sensor)
- 3 Reference plane

The actual product level during this adjustment is not important, because the min./max. adjustment is always carried out without changing the product level. These settings can be made ahead of time without the instrument having to be installed.

#### Basic adjustment - Min. adjustment

Proceed as follows:

1. Move from the measured value display to the main menu by pushing **[OK]**.

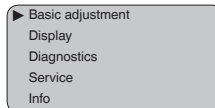

2. Select the menu item "Basic adjustment" with **[->]** and confirm with **[OK]**. Now the menu item "Min. adjustment" is displayed.

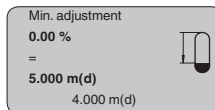

3. Prepare the % value for editing with **[OK]** and set the cursor to the requested position with **[->]**. Set the requested percentage value with **[+]** and save with **[OK]**. The cursor jumps now to the distance value.
4. Enter the distance value in m for empty vessel (e.g. distance from the sensor to the vessel bottom) corresponding to the percentage value.
5. Save the settings with **[OK]** and move to "Max. adjustment" with **[->]**.

### Basic adjustment - Max. adjustment

Proceed as follows:

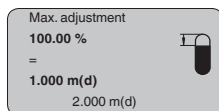

1. Prepare the % value for editing with **[OK]** and set the cursor to the requested position with **[->]**. Set the requested percentage value with **[+]** and save with **[OK]**. The cursor jumps now to the distance value.
2. Enter the appropriate distance value in m (corresponding to the percentage value) for the full vessel. Keep in mind that the max. level must lie below the dead band.
3. Save the settings with **[OK]** and move to "Medium selection" with **[->]**.

### Basic adjustment - Medium

Each product has different reflective properties. In addition, there are various interfering factors which have to be taken into account: agitated product surfaces and foam generation (with liquids); dust generation, material cones and echoes from the vessel wall (with solids). To adapt the sensor to these different conditions, you should first select "Liquid" or "Solid".

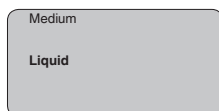

With solids, you can also choose between "Powder/Dust", "Granular/Pellets" or "Ballast/Pebbles".

Through this additional selection, the sensor is adapted perfectly to the product and measurement reliability, particularly in products with poor reflective properties, is considerably increased.

Enter the requested parameters via the appropriate keys, save your settings and jump to the next menu item with the **[->]** key.

### Basic adjustment - Vessel form

Apart from the medium, the vessel shape can also influence the measurement. To adapt the sensor to these measuring conditions, this menu item offers different options depending on whether liquid or bulk solid is selected. With "Liquids" these are "Storage tank", "Stilling tube", "Open vessel" or "Stirred vessel", with "Solid", "Silo" or "Bunker".

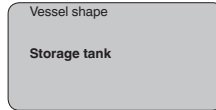

Enter the requested parameters via the appropriate keys, save your settings and jump to the next menu item with the **[->]** key.

### Basic adjustment - Damping

To suppress fluctuations in the measured value display, e. g. caused by an agitated medium surface, a damping can be set. This time can be between 0 and 999 seconds. Keep in mind that the reaction time of the entire measurement will then be longer and the sensor will react to measured value changes with a delay. In general, a period of a few seconds is sufficient to smooth the measured value display.

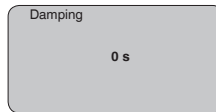

Enter the requested parameters via the appropriate keys, save your settings and jump to the next menu item with the **[->]** key.

### Basic adjustment - Linearization curve

A linearisation is necessary for all vessels in which the vessel volume does not increase linearly with the level - e.g. in a horizontal cylindrical or spherical tank - and the indication or output of the volume is required. Corresponding linearisation curves are preprogrammed for these vessels. They represent the correlation between the level percentage and vessel volume. By activating the appropriate curve, the volume percentage of the vessel is displayed correctly. If the volume should not be displayed in percent but e.g. in l or kg, a scaling can be also set in the menu item "Display".

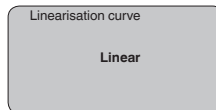

Enter the requested parameters via the appropriate keys, save your settings and jump to the next menu item with the **[->]** key.

### Menu section, display

#### Display - Indicated value

Radar, guided microwave and ultrasonic sensors deliver the following measured values:

- SV1 (Secondary Value 1): Percentage value after the adjustment
- SV2 (Secondary Value 2): Distance value before the adjustment
- PV (Primary Value): Linearised percentage value
- AI FB1 (Out)

In the menu item "Display" you can define which value should be indicated on the display.

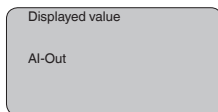

### Display - Backlight

A background lighting integrated by default can be adjusted via the adjustment menu. The function depends on the height of the supply voltage. See " *Technical data/Voltage supply*".

To maintain the function of the device, the lighting is temporarily switched off if the power supply is insufficient.



In the default setting, the lightning is switched off.

### Diagnosis - Peak value

The respective min. and max. measured values are saved in the sensor. The values are displayed in the menu item " *Peak values*".

- Min. and max. distance in m(d)
- Min. and max. temperature

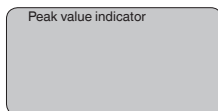

### Diagnosis - Measurement reliability

When non-contact level sensors are used, the measurement can be influenced by the respective process conditions. In this menu item, the measurement reliability of the level echo is displayed as a dB value. Measurement reliability equals signal strength minus noise. The higher the value, the more reliable the measurement. A well functioning measurement normally has a value > 10 dB.

### Diagnostics - Device status

The instrument status is displayed in this menu item. If no failure is detected by the sensor, " *OK*" will be displayed. If a failure is detected, there will be a sensor-specific flashing fault signal, for example " *E013*". The failure is also displayed in clear text, for example " *No measured value available*".



#### Information:

The fault message as well as the clear text indication are also carried out in the measured value display.

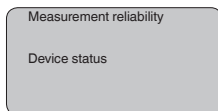

### Diagnosis - Curve selection

With ultrasonic sensors, the " **Echo curve**" represents the signal strength of the echoes over the measuring range. The unit of signal

strength is "dB". The signal strength enables the judgement of the quality of the measurement.

The "**False echo curve**" displays the saved false echoes (see menu "*Service*") of the empty vessel as signal strength in "dB" over the measuring range.

Up to 3000 measured values are recorded (depending on the sensor) when starting a "**Trend curve**". Then the values can be displayed on a time axis. The oldest measured values are always deleted.

In the menu item "*Choose curve*", the respective curve is selected.

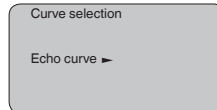

#### Information:

The trend recording is not activated when being shipped. It must be started by the user via the menu item "*Start trend curve*".

### Diagnosis - Curve presentation

A comparison of the echo curve and the false echo curve allows a more detailed evaluation of measurement reliability. The selected curve is updated continuously. With the **[OK]** key, a submenu with zoom functions is opened.

The following functions are available with "**Echo and false echo curve**":

- "X-Zoom": Zoom function for the meas. distance
- "Y-Zoom": 1, 2, 5 and 10x signal magnification in "dB"
- "Unzoom": Reset the presentation to the nominal measuring range without magnification

In the menu item "**Trend curve**" the following are available:

- "X-Zoom": Resolution
  - 1 minute
  - 1 hour
  - 1 day
- "Stop/Start": Interrupt a recording or start a new recording
- "Unzoom": Reset the resolution to minutes

As default setting, the recording pattern has 1 minute. With the adjustment software PACTware, this pattern can be also set to 1 hour or 1 day.

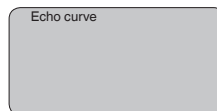

### Service - False signal suppression

High nozzles or vessel installations, such as e. g. struts or agitators as well as buildup and weld joints on the vessel walls, cause interfering reflections which can impair the measurement. A false echo storage detects and marks these false echoes, so that they are no longer taken into account for the level measurement. A false echo memory

should be created with low level so that all potential interfering reflections will be detected.

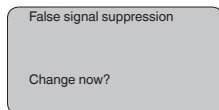

Proceed as follows:

1. Move from the measured value display to the main menu by pushing **[OK]**.
2. Select the menu item " *Service*" with **[->]** and confirm with **[OK]**. Now the menu item " *False signal suppression*" is displayed.
3. Confirm " *False signal suppression - Change now*" with **[OK]** and select in the below menu " *Create new*". Enter the actual distance from the sensor to the medium surface. All false signals in this area are detected by the sensor and saved after confirming with **[OK]**.



**Note:**

Check the distance to the medium surface, because if an incorrect (too large) value is entered, the existing level will be saved as a false signal. The level would then no longer be detectable in this area.

### Service - Extended setting

The menu item " *Extended setting*" offers the possibility to optimise OPTISOUND 3030 C for applications in which the level changes very quickly. To do this, select the function " *Quick level change > 1 m/min.*".

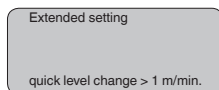

**Note:**

Since with the function " *Quick level change > 1 m/min.*" the generation of an average value of the signal processing is considerably reduced, false reflections by agitators or vessel installations can cause measured value fluctuations. A false signal suppression is thus recommended.

### Service - Simulation

In this menu item you simulate a user-defined level or pressure value via the current output. This allows you to test the signal path, e.g. through connected indicating instruments or the input card of the control system.

The following simulation variables are available:

- Percent
- Current
- Pressure (with pressure transmitters)
- Distance (with radar and guided radar (GWR))

With Profibus PA sensors, the selection of the simulated value is made via the "Channel" in the menu " *Basic adjustments*".

How to start the simulation:

1. Push **[OK]**
2. Select the requested simulation variable with **[->]** and confirm with **[OK]**.
3. Set the requested numerical value with **[+]** and **[->]**.
4. Push **[OK]**

The simulation is now running, with 4 ... 20 mA/HART a current is output and with Profibus PA or Foundation Fieldbus a digital value.

How to interrupt the simulation:

→ Push **[ESC]**



#### Information:

The simulation is automatically terminated 10 minutes after the last pressing of a key.

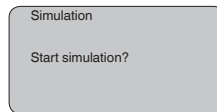

## Service - Reset

### Basic adjustment

If the "Reset" is carried out, the sensor resets the values of the following menu items to the reset values (see table): <sup>2)</sup>

Function	Reset value
Max. adjustment	Final value dead zone in m(d) <sup>3)</sup>
Min. adjustment	Meas. range end in m(d) <sup>4)</sup>
Medium	Liquid
Vessel shape	not known
Damping	0 s
Linearisation	Linear
Sensor-TAG	Sensor
Displayed value	AI-Out
Unit of measurement	m(d)

The values of the following menu items are *not* reset to the reset values (see table) with "Reset":

Function	Reset value
Language	No reset

### Default setting

Like basic adjustment, but in addition, special parameters are reset to default values. <sup>5)</sup>

<sup>2)</sup> Sensor-specific basic adjustment.

<sup>3)</sup> Depending on the sensor type, see chapter "Technical data".

<sup>4)</sup> Depending on the sensor type, see chapter "Technical data".

<sup>5)</sup> Special parameters are parameters which are set customer-specifically on the service level with the adjustment software PACTware.



**Peak value indicator**

The min. and max. distance and temperature values are reset to the actual value.

**Service - Adjustment unit** In this menu item you select the internal arithmetic unit of the sensor.

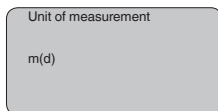
**Service - Language**

The sensor is already set to the ordered national language. In this menu item you can change the language. The following languages are available as of software version 3.50:

- Deutsch
- English
- Français
- Espanõl
- Pycckuu
- Italiano
- Netherlands
- Japanese
- Chinese

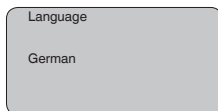
**Copy sensor data**

This function enables reading out parameter adjustment data as well as writing parameter adjustment data into the sensor via the display and adjustment module. A description of the function is available in the operating instructions manual "*Display and adjustment module*".

The following data are read out or written with this function:

- Measured value presentation
- Adjustment
- Medium
- Vessel shape
- Damping
- Linearisation curve
- Sensor-TAG
- Displayed value
- Unit of measurement
- Language

The following safety-relevant data are **not** read out or written:

- PIN

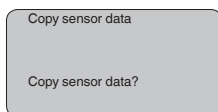

**Service - PIN**

In this menu item, the PIN is activated/deactivated permanently. Entering a 4-digit PIN protects the sensor data against unauthorized access and unintentional modifications. If the PIN is activated permanently, it can be deactivated temporarily (i.e. for approx. 60 min.) in any menu item. The instrument is delivered with the PIN set to 0000.

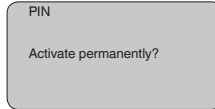

Only the following functions are permitted with activated PIN:

- Select menu items and show data
- Read data from the sensor into the display and adjustment module

**Menu section, info****Info**

In this menu item the most important sensor information can be displayed:

- Instrument type
- Serial number: 8-digit number, e.g. 12345678

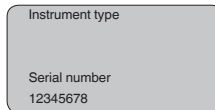

- Date of manufacture: Date of the factory calibration
- Software version: Edition of the sensor software

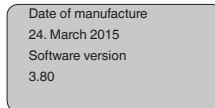

- Date of last change using PC: Date of the last change of sensor parameters via PC

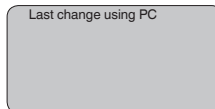

- Device-ID
- Sensor-TAG

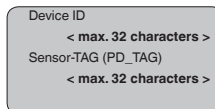

- Sensor details, e.g. approval, process fitting, seal, measuring cell, measuring range, electronics, housing, cable entry, plug, cable length etc.

Sensor characteristics  
Display now?

## 6.4 Menu schematic



### Information:

Depending on the version and application, the highlighted menu windows may not always be available.

### Basic adjustment

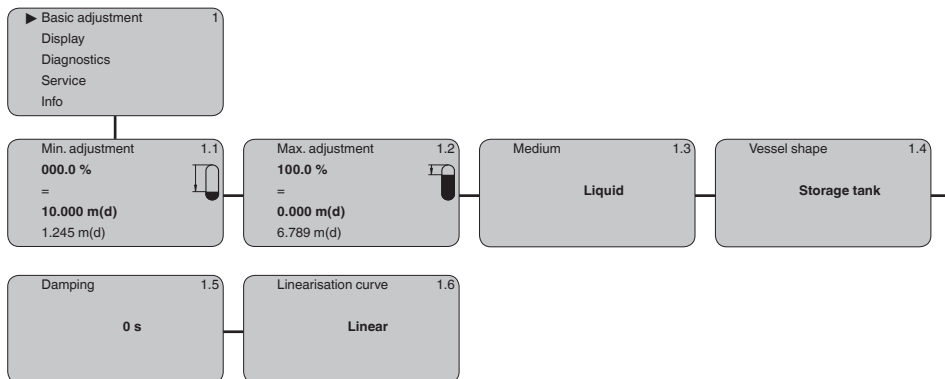

### Display

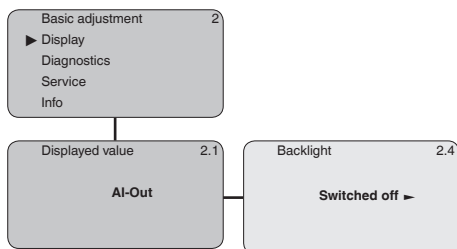

### Diagnostics

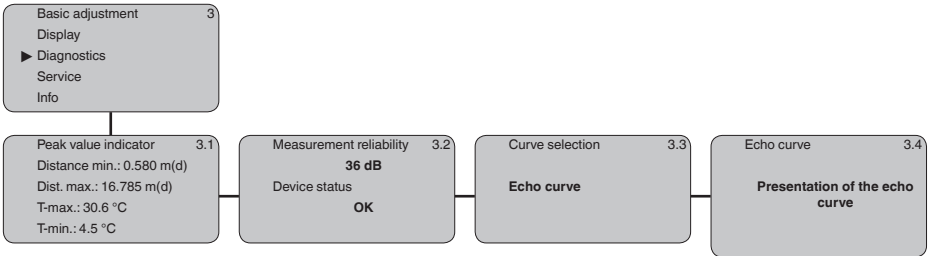

### Service

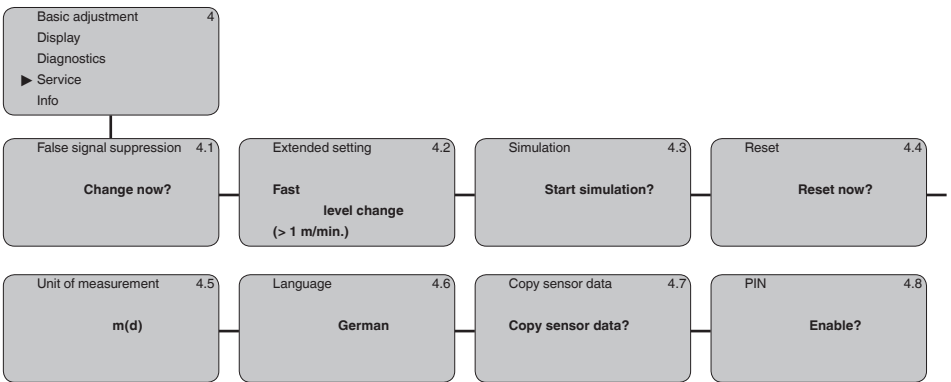

### Info

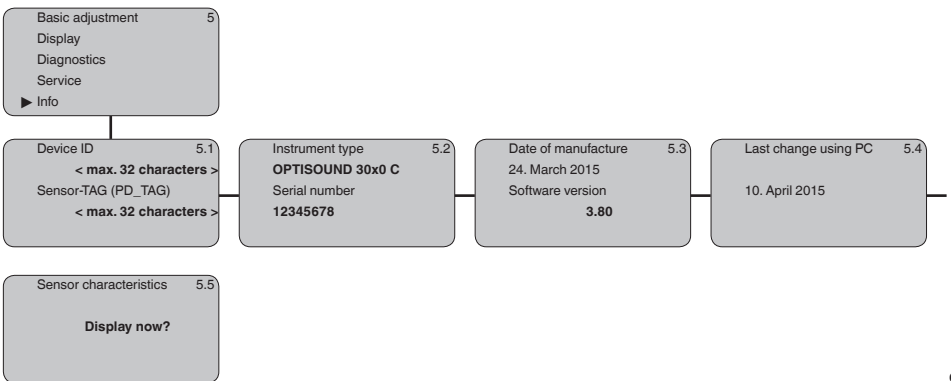

## 6.5 Saving the parameterisation data

### On paper

We recommended writing down the adjustment data, e.g. in this operating instructions manual, and archiving them afterwards. They are thus available for multiple use or service purposes.

### In the display and adjustment module

If the instrument is equipped with a display and adjustment module, the parameter adjustment data can be saved in it. The data remain permanently stored there even if the sensor supply fails. The procedure is described in menu item "*Copy sensor data*".

## 7 Maintenance and fault rectification

### 7.1 Maintenance

#### Maintenance

If the device is used properly, no special maintenance is required in normal operation.

#### Cleaning

The cleaning helps that the type label and markings on the instrument are visible.

Take note of the following:

- Use only cleaning agents which do not corrode the housings, type label and seals
- Use only cleaning methods corresponding to the housing protection rating

### 7.2 Rectify faults

#### Reaction when malfunction occurs

The operator of the system is responsible for taking suitable measures to rectify faults.

#### Causes of malfunction

The device offers maximum reliability. Nevertheless, faults can occur during operation. These may be caused by the following, e.g.:

- Sensor
- Process
- Voltage supply
- Signal processing

#### Fault rectification

The first measures to be taken are to check the output signal and evaluate fault messages via the display/adjustment module. The procedure is described below.

#### Checking Foundation Fieldbus

The following table describes possible errors and helps to remove them:

Error	Cause	Rectification
When an additional instrument is connected, the H1 segment fails.	Max. supply current of the segment coupler exceeded	Measure the current consumption, reduce size of segment
Measured value on the display and adjustment module does not correspond to the value in the PLC	The menu item " <i>Display - Display value</i> " is not set to " <i>AI-Out</i> "	Check values and correct, if necessary
Instrument does not appear during connection setup	Profibus DP cable pole-reversed	Check cable and correct, if necessary
	Incorrect termination	Check termination at the beginning and end points of the bus and terminate, if necessary, according to the specification
	Instrument not connected to the segment	Check and correct, if necessary



In Ex applications, the regulations for the wiring of intrinsically safe circuits must be observed.

### Error messages via the display and adjustment module

Error	Cause	Rectification
E013	no measured value available	Sensor in boot phase Sensor does not find an echo, e.g. due to faulty installation or wrong parameter adjustment
E017	Adjustment span too small	Carry out a fresh adjustment and increase the distance between min. and max. adjustment
E036	no operable sensor software	Carry out a software update or send instrument for repair
E041	Hardware error, electronics defective	Exchange the instrument or send it in for repair
E113	Communication conflict	Exchange the instrument or send it in for repair

### Reaction after fault rectification

Depending on the reason for the fault and the measures taken, the steps described in chapter "Setup" must be carried out again or must be checked for plausibility and completeness.

## 7.3 Exchanging the electronics module

If the electronics module is defective, it can be replaced by the user.



In Ex applications, only instruments and electronics modules with appropriate Ex approval may be used.

If there is no electronics module available on site, one can be ordered from the Krohne agency serving you.

## 7.4 How to proceed if a repair is necessary

If it is necessary to repair the instrument, please contact the responsible Krohne agency.

## 8 Dismount

### 8.1 Dismounting steps

**Warning:**

Before dismounting, be aware of dangerous process conditions such as e.g. pressure in the vessel or pipeline, high temperatures, corrosive or toxic media etc.

Take note of chapters "*Mounting*" and "*Connecting to voltage supply*" and carry out the listed steps in reverse order.

### 8.2 Disposal



Pass the instrument on to a specialised recycling company and do not use the municipal collecting points.

Remove any batteries in advance, if they can be removed from the device, and dispose of them separately.

If personal data is stored on the old device to be disposed of, delete it before disposal.

If you have no way to dispose of the old instrument properly, please contact us concerning return and disposal.



## 9 Supplement

### 9.1 Technical data

#### Note for approved instruments

The technical data in the respective safety instructions which are included in delivery are valid for approved instruments (e.g. with Ex approval). These data can differ from the data listed herein, for example regarding the process conditions or the voltage supply.

All approval documents can be downloaded from our homepage.

#### General data

##### Materials, wetted parts

- |   |   |
|---|---|
| – Process fitting                           | UP (glass-fibre reinforced polyester resin) |
| – Transducer diaphragm                      | 316Ti                                       |
| – Seal transducer diaphragm/process fitting | EPDM  |

##### Materials, non-wetted parts

- |                                   |   |
|-----------------------------------|---|
| – Mounting strap                  | 1.4301  |
| – Compression flange              | PPH, 316L   |
| – Housing                         | Plastic PBT (polyester), Alu die-casting, powder-coated, 316L |
| – Seal, housing lid               | Silicone SI 850 R   |
| – Inspection window housing cover | Polycarbonate (UL-746-C listed), glass <sup>6)</sup>          |
| – Ground terminal                 | 316Ti/316L  |
| – Cable gland                     | PA, stainless steel, brass                                    |
| – Sealing, cable gland            | NBR   |
| – Blind plug, cable gland         | PA  |

Weight	2.7 ... 5.7 kg (6 ... 12.6 lbs), depending on the process fitting and housing
--------	---

#### Input variable

Measured variable	distance between lower edge of the transducer and medium surface
-------------------	--

##### Measuring range

- |               |                       |
|---------------|-----------------------|
| – Liquids     | up to 15 m (49.21 ft) |
| – Bulk solids | up to 7 m (22.97 ft)  |

blocking distance	0.6 m (1.969 ft)
-------------------	------------------

#### Output variable

##### Output

- |                  |   |
|------------------|---|
| – Signal         | digital output signal, Foundation Fieldbus protocol |
| – Physical layer | according to IEC 61158-2                            |

<sup>6)</sup> Glass (with Aluminium and stainless steel precision casting housing)

Cycle time	min. 1 s (dependent on the parameter setting)
- Damping (63 % of the input variable)	0 ... 999 s, adjustable
- Met NAMUR recommendation	NE 43
Channel Numbers	
- Channel 1	Primary value
- Channel 2	Secondary value 1
- Channel 3	Secondary value 2
Transmission rate	31.25 Kbit/s
Current value	10 mA, $\pm 0.5$ mA
Resolution, digital	> 1 mm (0.039 in)

### Deviation

Deviation <sup>7)</sup>  $\leq 6$  mm (meas. distance  $\leq 3.0$  m/9.843 ft)

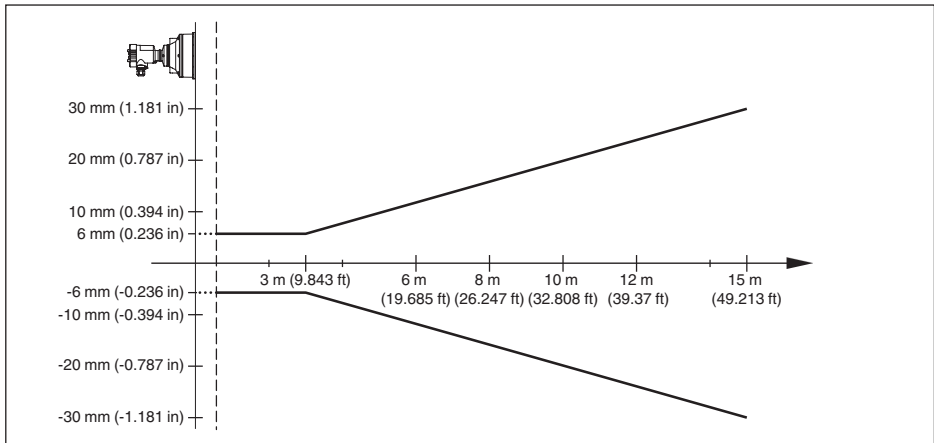

Fig. 26: Deviation OPTISOUND 3030 C

### Reference conditions to measurement accuracy (according to DIN EN 60770-1)

Reference conditions according to DIN EN 61298-1

- Temperature	+18 ... +30 °C (+64 ... +86 °F)
- Relative humidity	45 ... 75 %
- Air pressure	860 ... 1060 mbar/86 ... 106 kPa (12.5 ... 15.4 psig)

Other reference conditions

- Reflector	ideal reflector, e.g. metal plate 2 x 2 m (6.56 x 6.56 ft)
- False reflections	Biggest false signal, 20 dB smaller than the useful signal

### Measuring characteristics

Ultrasonic frequency	35 kHz
Interval	> 2 s (dependent on the parameter adjustment)

<sup>7)</sup> Incl. non-linearity, hysteresis and non-repeatability.

Abstrahlwinkel at -3 dB	6°
Adjustment time <sup>8)</sup>	> 3 s (dependent on the parameter adjustment)

---

**Influence of the ambient temperature to the sensor electronics <sup>9)</sup>**

---

Average temperature coefficient of the zero signal (temperature error)	0.06 %/10 K
--	-------------

---

**Ambient conditions**

---

Ambient, storage and transport temperature	-40 ... +80 °C (-40 ... +176 °F)
--	----------------------------------

---

**Process conditions**

---

Process pressure	
– with compression flange	-20 ... 100 kPa/-0.2 ... 1 bar (-2.9 ... 14.5 psi)
– with mounting strap	0 kPa, since no seal possibility
Process temperature (transducer temperature)	-40 ... +80 °C (-40 ... +176 °F)
Vibration resistance	mechanical vibrations with 4 g and 5 ... 100 Hz <sup>10)</sup>

---

**Electromechanical data**

---

Cable entry	
– Single chamber housing	– 1 x cable gland M20 x 1.5 (cable: ø 5 ... 9 mm), 1 x blind plug M20 x 1.5 or: – 1 x closing cap ½ NPT, 1 x blind plug ½ NPT
– Double chamber housing	– 1 x cable gland M20 x 1.5 (cable: ø 5 ... 9 mm), 1 x blind plug M20 x 1.5 or: – 1 x closing cap ½ NPT, 1 x blind plug ½ NPT
Spring-loaded terminals for wire cross-section up to	2.5 mm <sup>2</sup> (AWG 14)

---

**Display and adjustment module**

---

Voltage supply and data transmission	through the sensor
Indication	LC display in dot matrix
Adjustment elements	4 keys
Protection rating	
– unassembled	IP20
– Mounted into the sensor without cover	IP40
Ambient temperature - Display and adjustment module	-20 ... +70 °C (-4 ... +158 °F)

<sup>8)</sup> Time to output the correct level (with max. 10 % deviation) after a sudden level change.

<sup>9)</sup> Relating to the nominal measuring range.

<sup>10)</sup> Tested according to the guidelines of German Lloyd, GL directive 2.

**Material**

– Housing	ABS
– Inspection window	Polyester foil

**Voltage supply**

Operating voltage	9 ... 32 V DC
Operating voltage $U_B$ with lighting switched on	12 ... 32 V DC
Power supply by/max. number of sensors	32

**Electrical protective measures****Protection rating**

– Plastic housing	IP66/IP67 (NEMA Type 4X)
– Aluminium and stainless steel housing	IP66/IP68 (0.2 bar) NEMA Type 6P <sup>11)</sup>

Connection of the feeding power supply unit Networks of overvoltage category III

**Altitude above sea level**

– by default	up to 2000 m (6562 ft)
– with connected overvoltage protection	up to 5000 m (16404 ft)

Pollution degree <sup>12)</sup> 4

Protection class II

**9.2 Device communication Foundation Fieldbus**

In the following, the necessary device-specific details are shown. You can find further information of Foundation Fieldbus on [www.fieldbus.com](http://www.fieldbus.com).

**Block diagram, measured value processing**

The following illustration shows the Transducer Block (TB) and Function block (FB) in simplified form.

<sup>11)</sup> A suitable cable is required for maintaining the protection rating.

<sup>12)</sup> When used with fulfilled housing protection

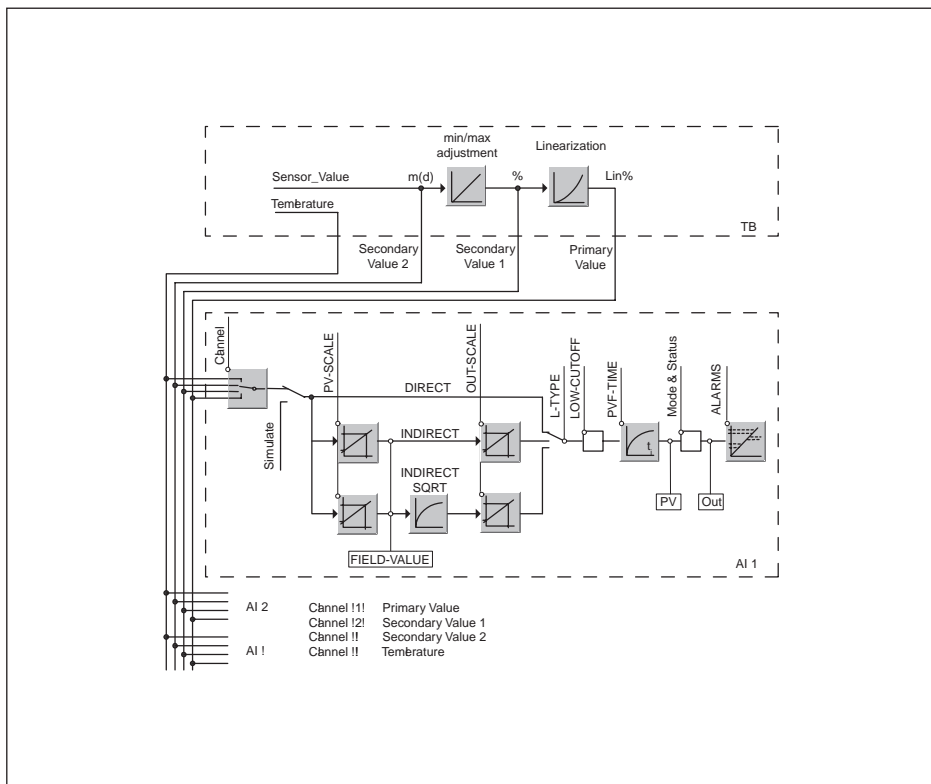

Fig. 27: OPTISOUND 3030 C measured value processing

### Diagram, adjustment

The following illustration shows the function of the adjustment:

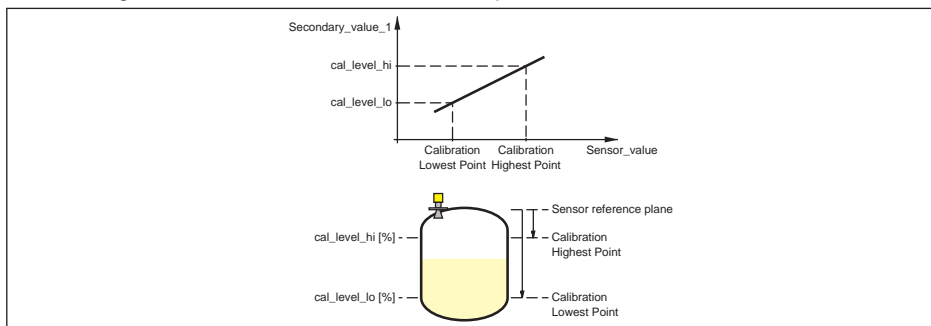

Fig. 28: Adjustment OPTISOUND 3030 C

### Parameter list for Device revision 3.0

The following list contains the most important parameters and their meaning:

- primary\_value
  - This is the process value after adjustment and Linearization with the status of the transducer block
- primary\_value\_unit
  - Unit code of 'Primary\_value'
- secondary\_value\_1
  - Value after min./max.-adjustment (level + level offset). Selected as input to AIFB by setting 'Channel' = 2. Unit derives from 'Secondary\_value\_1\_unit'
- secondary\_value\_1\_unit
  - Unit code of 'Secondary\_value\_1'
- secondary\_value\_2
  - Sensor value + sensor offset. Selected as input to AIFB by setting 'Channel' = 3. Unit derives from 'Secondary\_value\_2\_unit'
- secondary\_value\_2\_unit
  - Unit code of 'Secondary\_value\_2'
- sensor\_value
  - Raw sensor value, i.e. the uncalibrated measurement value from the sensor. Unit derives from 'Sensor\_range.unit'
- sensor\_range
  - Sensor\_range.unit' refers to 'Sensor\_value', 'Max/Min\_peak\_sensor\_value', 'Cal\_point\_hi/lo'
- simulate\_primary\_value
- simulate\_secondary\_value\_1
- simulate\_secondary\_value\_2
- Device Status
- Linearization Type
  - Possible types of linearization are: linear, user defined, cylindrical lying container, spherical container
- CURVE\_POINTS\_1\_10
  - X and Y values for the user defined linearization curve
- CURVE\_POINTS\_11\_20
  - X and Y values for the user defined linearization curve
- CURVE\_POINTS\_21\_30
  - X and Y values for the user defined linearization curve
- CURVE\_POINTS\_31\_33
  - X and Y values for the user defined linearization curve
- CURVE\_STATUS
  - Result of table plausibility check
- SUB\_DEVICE\_NUMBER
- SENSOR\_ELEMENT\_TYPE
- display\_source\_selector
  - Selects the type of value, which is displayed on the indicating and adjustment module
- max\_peak\_sensor\_value
  - Holds the maximum sensor value. Write access resets to current value. Unit derives from 'Sensor\_range.unit'
- min\_peak\_sensor\_value
  - Holds the minimum sensor value. Write access resets to current value. Unit derives from 'Sensor\_range.unit'
- CAL\_POINT\_HI
  - Min./max.-adjustment: Upper calibrated point of the sensor. It refers to 'Cal\_level\_hi'. The unit is defined in 'Sensor\_range.unit'hi

- CAL\_POINT\_LO
  - Min./max.-adjustment: Lower calibrated point of the sensor. It refers to 'Cal\_level\_lo'. The unit is defined in 'Sensor\_range.unit'
- CAL\_LEVEL\_HI
  - Min./max.-adjustment: Level at 'Cal\_point\_hi'. When writing 'Cal\_level\_hi' and 'Cal\_type' = 1 (Online) the 'Cal\_point\_hi' is automatically set to the current sensor value. The unit is defined in 'Level\_unit'
- CAL\_LEVEL\_LO
  - Min./max.-adjustment: Level at 'Cal\_point\_lo'. When writing 'Cal\_level\_lo' and 'Cal\_type' = 1 (Online), the 'Cal\_point\_lo' is automatically set to the current sensor value. The unit is defined in 'Level\_unit'
- CAL\_TYPE
  - Min./max.-adjustment: Defines type of calibration: Dry: no influence of sensor value. Online: current sensor value determines 'Cal\_point\_hi/lo'
- level
  - Value after min./max. adjustment
- level\_unit
  - Unit code of 'Level', 'Level\_offset', 'Cal\_level\_hi', 'Cal\_level\_lo'
- level\_offset
  - Offset that is added to the 'Level' value. Unit derives from 'Level\_unit'
- SENSOR\_OFFSET
  - Offset that is added to the 'Sensor\_value'. Unit derives from 'Sensor\_range.unit'
- end\_of\_operation\_range
  - Set up to suit the process conditions
- begin\_of\_operation\_range
  - Set up to suit the process conditions
- product\_type
  - Set up to suit the process conditions. If Special-Parameter adjustment has been utilized this parameter cannot be written
- liquids\_medium\_type
  - Set up to suit the process conditions. If Special-Parameter adjustment has been utilized this parameter cannot be written
- solids\_medium\_type
  - Set up to suit the process conditions. If Special-Parameter adjustment has been utilized this parameter cannot be written
- liquids\_vessel\_type
  - Set up to suit the process conditions. If Special-Parameter adjustment has been utilized this parameter cannot be written
- solids\_vessel\_type
  - Set up to suit the process conditions. If Special-Parameter adjustment has been utilized this parameter cannot be written
- fast\_level\_change
  - Set up to suit the process conditions. If Special-Parameter adjustment has been utilized this parameter cannot be written
- first\_echo\_factor
  - Set up to suit the process conditions
- pulse\_velocity\_correction
  - Set up to suit the process conditions
- echo\_quality
  - Signal/Noise ratio
- empty\_vessel\_curve\_corr\_dist
  - Distance from the sensor to the product surface. Unit derives from 'Sensor\_range.unit'
- empty\_vessel\_curve\_corr\_op\_code

- Update, create new or delete the empty vessel curve
- sound\_velocity
  - Set up to suit the process conditions
- sound\_velocity\_unit
  - Unit code of 'Sound\_velocity'
- Temperature
  - Process temperature. Selected as input to AIFB by setting 'Channel' = 4. Unit derives from 'Temperature.unit'
- temperature\_unit
  - Unit code of 'Temperature', 'Max./Min.\_peak\_temperature\_value'
- max\_peak\_temperature\_value
  - Holds the maximum process temperature. Write access resets to current value. Unit derives from 'Temperature.unit'
- min\_peak\_temperature\_value
  - Holds the minimum process temperature. Write access resets to current value. Unit derives from 'Temperature.unit'

### 9.3 Dimensions

#### Housing

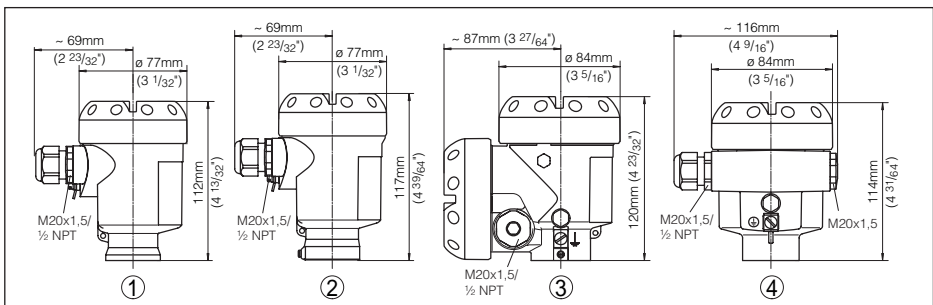

Fig. 29: Housing versions in protection rating IP66/IP67 and IP66/IP68, 0.2 bar (with integrated display and adjustment module the housing is 9 mm/0.35 in higher or wider)

- 1 Plastic housing
- 2 Stainless steel housing
- 3 Aluminium double chamber housing
- 4 Aluminium housing



## OPTISOUND 3030 C

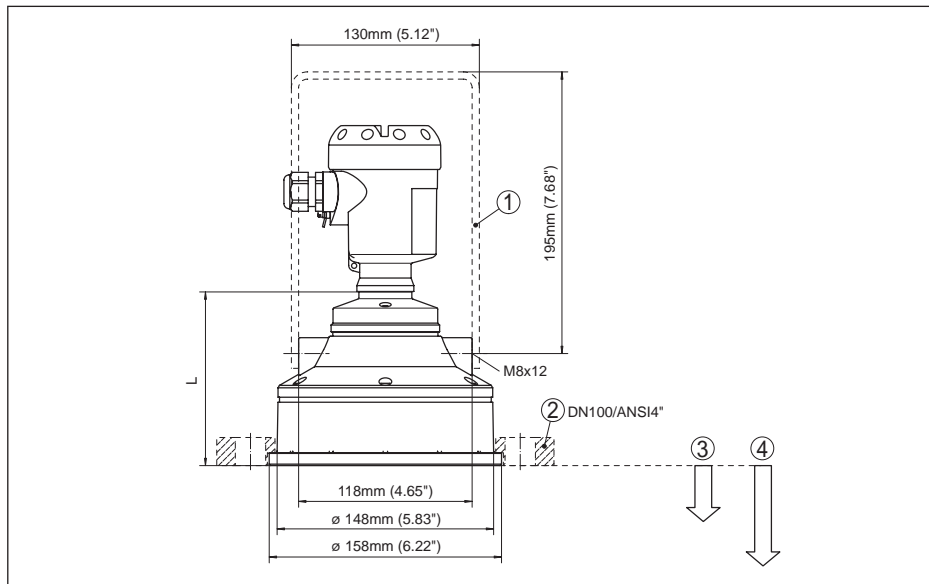

Fig. 30: OPTISOUND 3030 C, dimension L for aluminium housing = 118 mm (4.646"), for plastic housing = 112 mm (4.409"), for stainless steel housing = 107 mm (4.213")

- 1 Mounting strap
- 2 Compression flange
- 3 Dead zone: 0.6 m (2 ft)
- 4 Measuring range: with liquids up to 15 m (49.21 ft), with solids up to 7 m (22.97 ft)

## 9.4 Trademark

All the brands as well as trade and company names used are property of their lawful proprietor/originator.



## **KROHNE - Products, Solutions and Services**

- Process instrumentation for flow, level, temperature, pressure measurement and process analytics
- Flow metering, monitoring, wireless and remote metering solutions
- Engineering, commissioning, calibration, maintenance and training services

Head Office KROHNE Messtechnik GmbH  
Ludwig-Krohne-Straße 5  
47058 Duisburg (Germany)  
Tel.: +49 (0) 203 301 0  
Tel.: +49 (0) 203 301 10389  
info@krohne.de

The current list of all KROHNE contacts and addresses can be found at:  
[www.krohne.com](http://www.krohne.com)

**KROHNE**