



SU 501 Ex Handbook

Switch Amplifier

Controller

Contents

1	About this document	3
1.1	Function	3
1.2	Target group	3
1.3	Symbols used.....	3
2	For your safety	4
2.1	Authorised personnel	4
2.2	Appropriate use.....	4
2.3	Warning about incorrect use.....	4
2.4	General safety instructions	4
2.5	CE conformity.....	5
2.6	Installation and operation in the USA and Canada	5
2.7	Safety instructions for Ex areas	5
3	Product description	6
3.1	Configuration.....	6
3.2	Principle of operation.....	6
3.3	Adjustment	7
3.4	Packaging, transport and storage.....	7
4	Mounting	8
4.1	General instructions	8
4.2	Mounting instructions	8
5	Connecting to power supply	11
5.1	Preparing the connection	11
5.2	Connection procedure.....	11
5.3	Wiring plan	12
6	Setup	13
6.1	Adjustment system	13
6.2	Adjustment elements.....	14
6.3	Function table.....	17
7	Maintenance and fault rectification	19
7.1	Maintenance	19
7.2	Rectify faults.....	19
7.3	How to proceed if a repair is necessary.....	21
8	Dismount	22
8.1	Dismounting steps.....	22
8.2	Disposal	22
9	Supplement	23
9.1	Technical data	23
9.2	Dimensions	25
9.3	Trademark	26

1 About this document

1.1 Function

This instruction provides all the information you need for mounting, connection and setup as well as important instructions for maintenance, fault rectification, the exchange of parts and the safety of the user. Please read this information before putting the instrument into operation and keep this manual accessible in the immediate vicinity of the device.

1.2 Target group

This operating instructions manual is directed to trained personnel. The contents of this manual must be made available to the qualified personnel and implemented.

1.3 Symbols used



Information, note, tip: This symbol indicates helpful additional information and tips for successful work.



Note: This symbol indicates notes to prevent failures, malfunctions, damage to devices or plants.



Caution: Non-observance of the information marked with this symbol may result in personal injury.



Warning: Non-observance of the information marked with this symbol may result in serious or fatal personal injury.



Danger: Non-observance of the information marked with this symbol results in serious or fatal personal injury.



Ex applications

This symbol indicates special instructions for Ex applications.



List

The dot set in front indicates a list with no implied sequence.



Sequence of actions

Numbers set in front indicate successive steps in a procedure.



Battery disposal

This symbol indicates special information about the disposal of batteries and accumulators.

2 For your safety

2.1 Authorised personnel

All operations described in this documentation must be carried out only by trained, qualified personnel authorised by the plant operator.

During work on and with the device, the required personal protective equipment must always be worn.

2.2 Appropriate use

SU 501 Ex is a universal controller for connection of level switches.

You can find detailed information about the area of application in chapter "*Product description*".

Operational reliability is ensured only if the instrument is properly used according to the specifications in the operating instructions manual as well as possible supplementary instructions.

2.3 Warning about incorrect use

Inappropriate or incorrect use of this product can give rise to application-specific hazards, e.g. vessel overflow through incorrect mounting or adjustment. Damage to property and persons or environmental contamination can result. Also, the protective characteristics of the instrument can be impaired.

2.4 General safety instructions

This is a state-of-the-art instrument complying with all prevailing regulations and directives. The instrument must only be operated in a technically flawless and reliable condition. The operator is responsible for the trouble-free operation of the instrument. When measuring aggressive or corrosive media that can cause a dangerous situation if the instrument malfunctions, the operator has to implement suitable measures to make sure the instrument is functioning properly.

During the entire duration of use, the user is obliged to determine the compliance of the necessary occupational safety measures with the current valid rules and regulations and also take note of new regulations.

The safety instructions in this operating instructions manual, the national installation standards as well as the valid safety regulations and accident prevention rules must be observed by the user.

For safety and warranty reasons, any invasive work on the device beyond that described in the operating instructions manual may be carried out only by personnel authorised by the manufacturer. Arbitrary conversions or modifications are explicitly forbidden. For safety reasons, only the accessory specified by the manufacturer must be used.

To avoid any danger, the safety approval markings and safety tips on the device must also be observed and their meaning read in this operating instructions manual.

2.5 CE conformity

The device fulfils the legal requirements of the applicable EU directives. By affixing the CE marking, we confirm successful testing of the product.

2.6 Installation and operation in the USA and Canada

This information is only valid for USA and Canada. Hence the following text is only available in the English language.

Installations in the US shall comply with the relevant requirements of the National Electrical Code (ANSI/NFPA 70).

Installations in Canada shall comply with the relevant requirements of the Canadian Electrical Code.

2.7 Safety instructions for Ex areas

For Ex applications, only devices with corresponding Ex approval may be used. Observe the Ex-specific safety instructions. These are an integral part of the operating instructions and are enclosed with every device with Ex approval.

3 Product description

3.1 Configuration

Scope of delivery

The scope of delivery encompasses:

- Controller SU 501 Ex
- Terminal socket
- Bridges (4 pieces)
- Coding pins (2x)
- Ex label
- Ex separating chamber
- Documentation
 - This operating instructions manual
 - Ex-specific "Safety instructions" (with Ex versions)
 - If necessary, further certificates

Constituent parts

The SU 501 Ex consists of:

- Controller SU 501 Ex

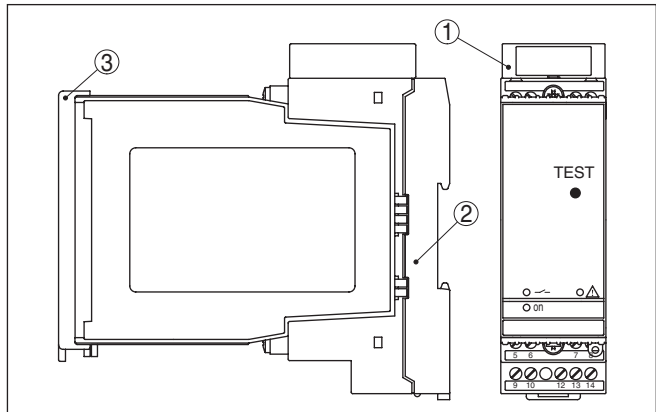

Fig. 1: SU 501 Ex

- 1 Ex separating chamber with Ex version
- 2 Terminal socket
- 3 Transparent cover

Type label

The type label contains the most important data for identification and use of the instrument:

- Article number
- Serial number
- Technical data
- Article numbers, documentation

3.2 Principle of operation

Application area

SU 501 Ex is a single controller for processing of vibrating level switches.

Functional principle The SU 501 Ex controller powers connected sensors and simultaneously processes their measuring signals.

When the medium reaches the switching point of the sensor, the sensor current changes. This is measured and evaluated by SU 501 Ex. The change causes the output relays to switch according to the set operating mode.

Voltage supply Wide range power supply unit with 20 ... 253 V AC/DC for worldwide use.

Detailed information about the power supply can be found in chapter "*Technical data*".

3.3 Adjustment

All adjustment elements are located under a hinged front cover. The operating mode and the switching delay can be set via a DIL switch block. In addition, the correct function of the measuring system can be checked with a test key.

3.4 Packaging, transport and storage

Packaging Your instrument was protected by packaging during transport. Its capacity to handle normal loads during transport is assured by a test based on ISO 4180.

The packaging of standard instruments consists of environment-friendly, recyclable cardboard. For special versions, PE foam or PE foil is also used. Dispose of the packaging material via specialised recycling companies.

Transport Transport must be carried out in due consideration of the notes on the transport packaging. Nonobservance of these instructions can cause damage to the device.

Transport inspection The delivery must be checked for completeness and possible transit damage immediately at receipt. Ascertained transit damage or concealed defects must be appropriately dealt with.

Storage Up to the time of installation, the packages must be left closed and stored according to the orientation and storage markings on the outside.

Unless otherwise indicated, the packages must be stored only under the following conditions:

- Not in the open
- Dry and dust free
- Not exposed to corrosive media
- Protected against solar radiation
- Avoiding mechanical shock and vibration
- Storage and transport temperature see chapter "*Supplement - Technical data - Ambient conditions*"
- Relative humidity 20 ... 85 %

Storage and transport temperature

4 Mounting

4.1 General instructions

Installation location

SU 501 Ex controller with plug-in socket for mounting on carrier rail according to EN 50022.

Transparent cover

The front plate of SU 501 Ex can be provided with a lead-sealable transparent cover to protect the instrument against unauthorised or inadvertent adjustment. See the following figure on how to remove the transparent cover.

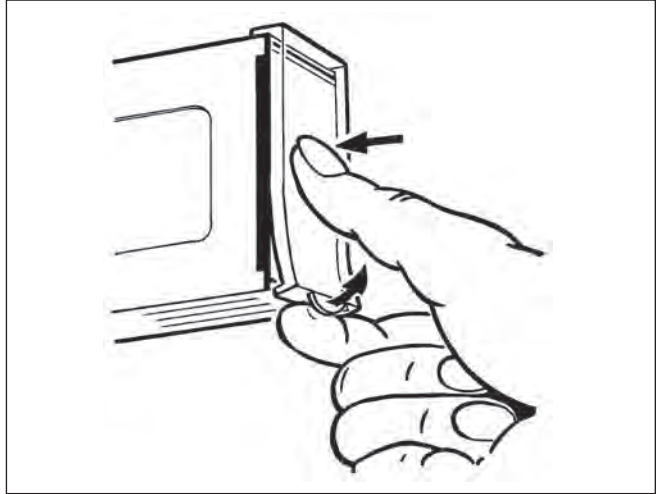

Fig. 2: Removing the transparent cover

Housing IP65

For moisture-protected mounting outside the switching cabinet, we offer an insulated protective housing with transparent cover (IP65) for surface mounting.

In this housing you can mount a maximum of 3 instruments of 36 mm width.

4.2 Mounting instructions

Installation

The plug-in socket is constructed for carrier rail mounting according to EN 50022. Operating voltage is connected to terminals 9 and 10. For neighbouring controllers, it is possible to continue connection L1 and N directly via the supplied bridges.



Danger:

The bridges must never be used with single instruments or at the end of a row of instruments. If this rule is not heeded, there is a danger of coming into contact with the operating voltage or causing a short circuit.



A SU 501 Ex in Ex version is an auxiliary, intrinsically safe instrument and may not be installed in explosion-endangered areas.

Ex separating chamber

Before setup, the Ex separating chamber must be attached (as shown below) with Ex versions. Safe operation can be only ensured if the operating instructions manual and the EG type approval certificate are observed. SU 501 Ex must not be opened.

Close the upper terminals according to the following illustration.

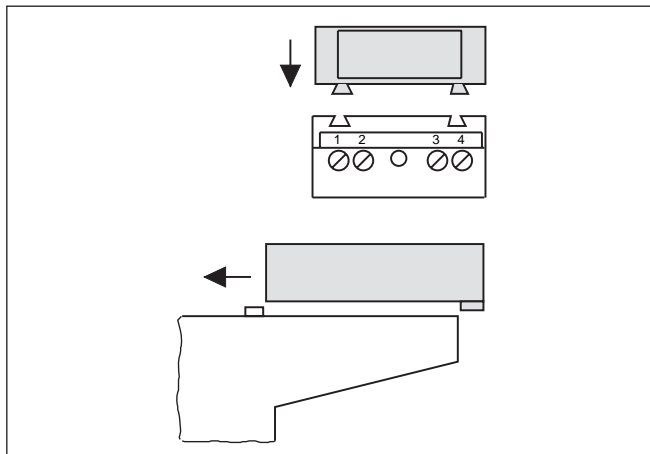

Fig. 3: Mounting the separating chamber

Instrument coding

All controllers are provided with different gaps depending on type and version (mechanical coding).

The plug-in socket is provided with coded pins that can be inserted to prevent accidental interchanging of the various instrument types.



With a SU 501 Ex in Ex version, the supplied coded pins (type coded pin and Ex coded pin) must be inserted by the user according to the below table.

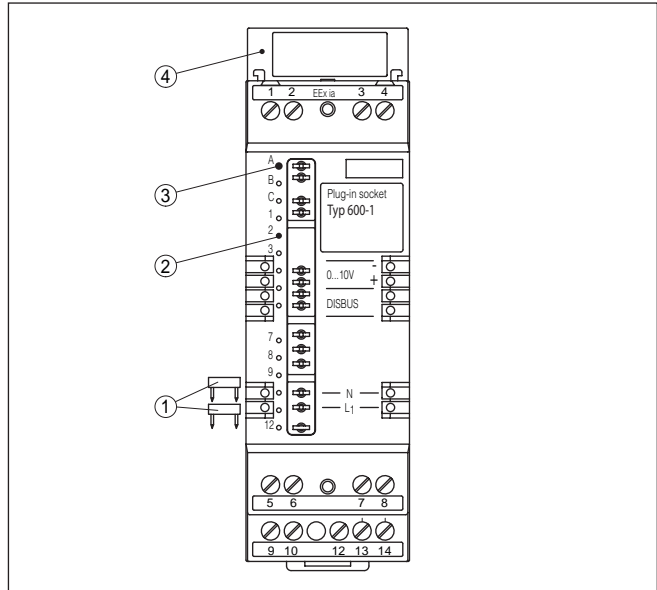

Fig. 4: Plug-in socket SU 501 Ex

- 1 Bridges for looping the operating voltage
- 2 Type coding for SU 501 Ex
- 3 Ex coding with Ex version
- 4 Ex separating chamber

5 Connecting to power supply

5.1 Preparing the connection

Note safety instructions

Always keep in mind the following safety instructions:

- Connect only in the complete absence of line voltage
- If overvoltage surges are expected, overvoltage arresters should be installed.

Take note of safety instructions for Ex applications



In hazardous areas you must take note of the respective regulations, conformity and type approval certificates of the sensors and power supply units.

Voltage supply

The power supply can be 20 ... 250 V AC, 50/60 Hz or 20 ... 72 V DC.

Connection cable

The voltage supply of SU 501 Ex is connected with standard cable according to the national installation standards.

The sensors are connected with standard two-wire cable without screen. If electromagnetic interference is expected which is above the test values of EN 61326 for industrial areas, screened cable should be used.

Use cable with round cross-section. A cable outer diameter of 5 ... 9 mm (0.2 ... 0.35 in) ensures the seal effect of the cable gland. If you are using cable with a different diameter or cross-section, exchange the seal or use a suitable cable gland.

Cable screening and grounding

Connect the cable screen on both ends to ground potential. In the sensor, the screen must be connected directly to the internal ground terminal. The ground terminal on the outside of the sensor housing must be connected to the potential equalisation (low impedance).

If potential equalisation currents are expected, the screen connection on SU 501 Ex must be made via a ceramic capacitor (e. g. 1 nF, 1500 V). The low frequency potential equalisation currents are thus suppressed, but the protective effect against high frequency interference signals remains.

Connection cable for Ex applications



Take note of the corresponding installation regulations for Ex applications. In particular, make sure that no potential equalisation currents flow over the cable screen. In case of grounding on both sides this can be achieved by the use of a capacitor or a separate potential equalisation.

5.2 Connection procedure

Move on to electrical connection and proceed as follows:

1. Snap the socket without SU 501 Ex onto the carrier rail
2. Connect sensor cable to terminal 1 and 2, and where applicable, connect the screen
3. Connect power supply (switched off) to terminal 9 and 10
4. Insert SU 501 Ex into the plug-in socket and screw it down tightly

The electrical connection is finished.



Before setting up Ex versions, make sure the Ex separating chamber is plugged (above the sensor terminals). The pins for type and Ex coding must also be inserted correctly.

5.3 Wiring plan

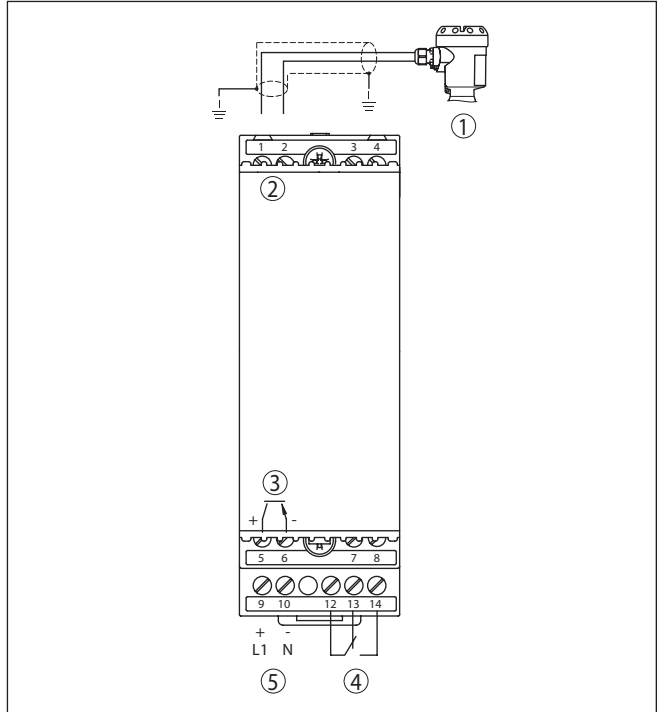

Fig. 5: Wiring plan SU 501 Ex

- 1 Sensor
- 2 Sensor input
- 3 Transistor output
- 4 Relay output
- 5 Voltage supply

6 Setup

6.1 Adjustment system

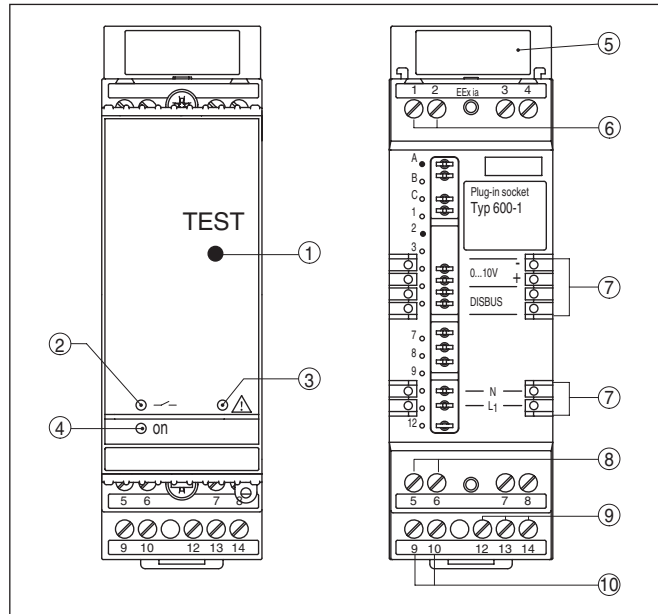

Fig. 6: Display and adjustment elements

- 1 Test key
- 2 Control lamp - level relay (LED yellow)
- 3 Control lamp - Fault signal (LED red)
- 4 Control lamp - Operating voltage (LED green)
- 5 Ex separating chamber
- 6 Terminal for probe
- 7 Sockets for bridges
- 8 Transistor output
- 9 Relay output
- 10 Voltage supply

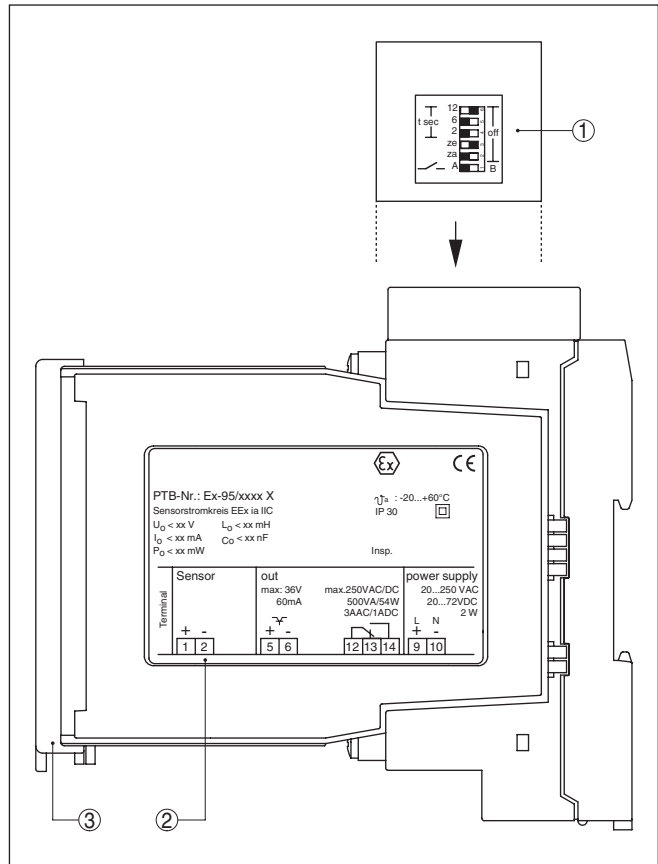

Fig. 7: Display and adjustment elements

- 1 DIL switch block
- 2 Type label
- 3 Transparent cover

6.2 Adjustment elements

Control lamps

Control lamps (LED) in the front plate indicate operation, switching status and fault signal.

- Green
 - Operating control lamp
 - Mains voltage on, instrument is operating
- Red
 - Fault indicator
 - Fault on the sensor circuit due to sensor failure or line break
 - The relay deenergises in case of failure
- Yellow

- Relay control lamp
- The yellow relay control lamp reacts depending on the set mode (A/B)
- The relay control lamp generally indicates the activated (energized) condition of the relay
- A dark relay control lamp means that the relay is deenergised (transistor blocks)

DIL switch block

Laterally on top (covered when mounted) there is a DIL switch block with six switches. The individual switches are assigned as follows:

- 1 - A/B mode
 - A - Max. detection or overflow protection
 - B - Min. detection or dry run detection
- 2 - Switch off delay (za)
- 3 - Switch on delay (ze)
- 4 - Switching delay 2 s
- 5 - Switching delay 6 s
- 6 - Switching delay 12 s

With switch 1 you can adjust the mode (A - overflow protection or B - dry run protection).

With switches 2 and 3 you can set switch off and/or switch on delays independent of each other.

The delay refers to the switching function of the relay.

In the example (see previous illustration), mode A (max. detection of overflow protection) is selected (switch 1). The switch off delay is activated (switch 2) and the switching delay is set to 8 seconds (switch 4, 5 and 6).

With switches 4, 5 and 6 you can adjust the switching delay. The times of the activated time switches accumulate. If the switch on (ze) and switch off delay (za) are switched on together, the set time applies to both delay modes.

Hence the relay deenergises with 8 seconds delay time when the switching point is reached.



Information:

Keep in mind that the switching delay of the sensor and controller accumulate.

Switch	1	2	3	4	5	6
Time		za	ze	2 s	6 s	12 s
0.2 s	A/B	off	off	off	off	off
0.5 s	A/B	¹⁾		off	off	off
2 s	A/B			on	off	off
6 s	A/B			off	on	off
8 s	A/B			on	on	off

¹⁾ Set alternately switch 2 and/or 3 to "on". The times apply to the adjusted delay mode.

Switch	1	2	3	4	5	6
Time		za	ze	2 s	6 s	12 s
12 s	A/B			off	off	on
14 s	A/B			on	off	on
18 s	A/B			off	on	on
20 s	A/B			on	on	on

Function monitoring

The measuring system is continuously monitored. The following criteria are checked:

- Line break and shortcircuit (two-wire cable)
- Interruption of the connection cable to the piezo elements
- Corrosion or damage on the tuning fork (vibrating rod)
- Break of the tuning fork (vibrating rod)
- Loss of vibration
- Too low vibrating frequency
- Medium penetration into the sensor (from inside vessel)

Test key

In systems with OPTISWITCH level switches in conjunction with a two-wire electronics module, a function test can be carried out. SU 501 Ex has an integrated test key. The test key is lowered in the front plate of the controller. Push the test key with a suitable object (screwdriver, pen etc.).

By pushing the key, the system is checked on the following criteria:

- Switching function of the switching outputs
- Potential separation of the outputs
- The signal processing of the controller

After pushing the test key, the complete measuring system is checked on correct function. The following operating conditions are simulated during the test:

- Fault message
- Empty signal
- Full signal

Check if all three switching conditions occur in the correct sequence and the stated duration. If not, there is a fault in the measuring system (see chapter "*Fault rectification*").



Note:

Keep in mind that downstream connected devices are activated during the function test. This allows you to check the correct function of the measuring system.

Test procedure

After releasing the key.

	A-mode	B-mode
1 Simulation of a fault signal (approx. 3 s) Level relay deenergised	Relay control lamp off	Relay control lamp off

	A-mode	B-mode
1 Simulation of a fault signal Fault indicator	Failure lamp lights	Failure lamp lights
2 Simulation an empty signal (approx. 1.5 s) Level relay energised	Relay control lamp lights	Relay control lamp off
2 Simulation of an empty signal Fault indicator	Failure lamp off	Failure lamp off
3 Simulation of a full signal (approx. 1.5 s) Level relay deenergised	Relay control lamp off	Relay control lamp lights
3 Simulation of a full signal Fault indicator	Failure lamp off	Failure lamp off
4 Return to the current operating condition (covered/uncovered)		

Evaluation

Check the procedure of the function test. Note the following criteria for assessment of the result:

Test passed

If all three switching conditions occur in the correct sequence and the specified duration, then the test is passed and the instrument functions correctly.



Test not passed

- The specified times deviate considerably from the table (> 3 s)
- One of the switching conditions remains unchanged
- No start-up of the test - no signal sequence









6.3 Function table

The following table provides an overview of the switching conditions depending on the set mode and the level.

The mode switch on the sensor (if available) must be set to max. operation.

Mode on the controller	Sensor (max. operation)		Controller		
	Level	Signal current - Sensor	Signal lamp - Switching output (yellow)	Control lamp - Failure (red)	Outputs
Mode A Overflow protection		approx. 8 mA		○	Relay energized transistor conducts
Mode A Overflow protection		approx. 16 mA	○	○	Relay deenergized transistor blocks

27953-EN-191108

Mode on the controller	Sensor (max. operation)		Controller		
	Level	Signal current - Sensor	Signal lamp - Switching output (yellow)	Control lamp - Failure (red)	Outputs
Mode B Dry run protection		approx. 16 mA			Relay energized transistor conducts
Mode B Dry run protection		approx. 8 mA			Relay deenergized transistor blocks
Fault message (mode A/B)	any	approx. 1.8 mA			Relay deenergized transistor blocks

7 Maintenance and fault rectification

7.1 Maintenance

Maintenance

If the device is used properly, no special maintenance is required in normal operation.

Cleaning

The cleaning helps that the type label and markings on the instrument are visible.

Take note of the following:

- Use only cleaning agents which do not corrode the housings, type label and seals
- Use only cleaning methods corresponding to the housing protection rating

7.2 Rectify faults

Reaction when malfunction occurs

The operator of the system is responsible for taking suitable measures to rectify faults.

Causes of malfunction

The device offers maximum reliability. Nevertheless, faults can occur during operation. These may be caused by the following, e.g.:

- Measured value from sensor not correct
- Voltage supply
- Interference in the cables

Fault rectification

The first measure to be taken is to check the input and output signals. The procedure is described as follows. In many cases the causes can be determined this way and faults can be easily rectified.

Fault

Error	Cause	Rectification
The red failure control lamp (LED) of the controller lights	Sensor not connected correctly	In Ex systems, make sure that the Ex protection is not influenced by the measuring instruments used. Measure the current value on the signal cable to the sensor Faults in the sensor causing a current change to below 3.7 mA or over 21 mA lead to a fault signal in the controllers
	Sensor not connected correctly	In Ex systems, make sure that the Ex protection is not influenced by the measuring instruments used. Measure the voltage on the connection cable The terminal voltage of the sensor is at least 12 V in normal condition

Error	Cause	Rectification
The red failure control lamp (LED) of the controller lights	Current value ≤ 3.7 mA	<p>Measure the current value on the signal cable to the sensor</p> <p>Check all connections and connection cables to the sensor</p> <p>The voltage should be approx. 17 ... 20 V</p> <p>If the value is below 17 V, probably the controller is defective.</p> <p>Exchange the controller or send it in for repair</p> <p>If the red failure lamp continues to light, separate the sensor from the connection cable and connect a resistor of 1 kΩ instead on the controller</p> <p>If the failure lamp continues to light, the controller is defective</p> <p>Exchange the controller or send it in for repair</p> <p>Should the failure lamp extinguish, you can connect the sensor again. Separate the controller from the connection cable and connect a resistor of 1 kΩ to the sensor input</p> <p>If the failure lamp continues to light, the connection cable is probably interrupted</p> <p>Check the connection cable to the sensor</p> <p>Should the failure lamp extinguish, the sensor will be defective</p> <p>Exchange the sensor or send it in for repair</p>
The red failure control lamp (LED) of the controller lights	Current value ≥ 21 mA	<p>Measure the current value on the signal cable to the sensor</p> <p>Check all connections and connection cables to the sensor</p> <p>If the red failure lamp continues to light, separate the sensor from the connection cable and connect a resistor of 1 kΩ instead on the controller</p> <p>If the failure lamp extinguishes, the sensor is defective. Check the connected sensor</p> <p>If the failure lamp continues to light, connect the sensor again. Separate controller from the connection cable and connect a resistor of 1 kΩ to the sensor input.</p> <p>If the failure lamp extinguishes, this is probably due to a shortcircuit in the connection cable</p> <p>Check the connection cable to the sensor</p> <p>If the failure lamp continues to light, the controller is defective</p> <p>Exchange the controller or send it in for repair</p>
Malfunction during function test	After pushing the test key, the switching conditions do not occur in the correct sequence or correct duration, e.g. no full signal is output.	<p>Measure the line resistance</p> <p>If the cable is highly resistive, bring it to a normal resistance, e.g. check terminals and cable connections on corrosion</p>

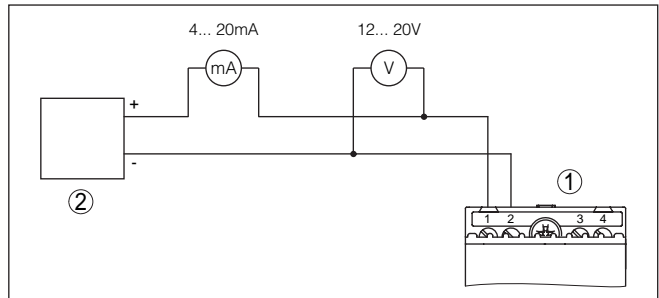

Fig. 8: Connection of a multimeter

- 1 Controller SU 501 Ex
- 2 Sensor

Reaction after fault rectification

Depending on the reason for the fault and the measures taken, the steps described in chapter "Set up" may have to be carried out again.

7.3 How to proceed if a repair is necessary

If it is necessary to repair the instrument, please contact the responsible Krohne agency.

8 Dismount

8.1 Dismounting steps

Take note of chapters "*Mounting*" and "*Connecting to voltage supply*" and carry out the listed steps in reverse order.

8.2 Disposal

The instrument consists of materials which can be recycled by specialised recycling companies. We use recyclable materials and have designed the electronics to be easily separable.

WEEE directive

The instrument does not fall in the scope of the EU WEEE directive. Article 2 of this Directive exempts electrical and electronic equipment from this requirement if it is part of another instrument that does not fall in the scope of the Directive. These include stationary industrial plants.

Pass the instrument directly on to a specialised recycling company and do not use the municipal collecting points.

If you have no way to dispose of the old instrument properly, please contact us concerning return and disposal.

9 Supplement

9.1 Technical data

Note for approved instruments

The technical data in the respective safety instructions are valid for approved instruments (e.g. with Ex approval). In some cases, these data can differ from the data listed herein.

All approval documents can be downloaded from our homepage.

General data

Series	Module unit with plug-in socket for mounting on carrier rail 35 x 7.5 or 35 x 5 according to EN 50022
Weight	170 g (6 oz)
Housing material	Noryl SE100, Lexan 920A
Socket material	Noryl SE100, Noryl SE1 GFN3

Voltage supply

Operating voltage	20 ... 250 V AC, 50/60 Hz, 20 ... 72 V DC
Max. power consumption	3 W (3 ... 18 VA)

Sensor input

Quantity	1
Data transmission	Analogue
Hysteresis	100 μ A
Switching threshold	12 mA
Current limitation	24 mA (permanently short-circuit proof)
Sensor operating voltage	15 ... 18 V DC
Detection line break	\leq 3.7 mA
Detection shortcircuit	\geq 21 mA
Configuration, connection cable	2-wire
Resistance per conductor	max. 35 Ω

Relay output

Number, function	1 x switching relay (spdt)
Switching delay	0.2 ... 20 s, directional switching
Mode	A/B switch (A - max. detection or overflow protection, B - min. detection or dry run protection)
Contact	1 x spdt
Contact material	AgNi 0.15 hard gold-plated
Switching voltage	\geq 10 mV DC, \leq 253 V AC/DC
Switching current	\geq 10 μ A DC, \leq 3 A AC, 1 A DC
Breaking capacity	\leq 500 VA, \leq 54 W DC

Transistor output

Number, function	1 output, synchronously switching with the relay
------------------	--

Galvanic separation	Floating
Maximum values	
– U_B	36 V DC
– I_B	≤ 60 mA, short-circuit proof
Transistor voltage loss (U_{CE})	approx. 1.5 V at I_B 60 mA
Inverse current (I_0)	< 10 μ A

Adjustment elements

DIL switch block	for preadjustment of the switching delay and mode
Test key	for function test
Control lamps in the front plate	
– Status indication operating voltage	LED green
– Status indication fault signal	LED red
– Status indication switching point control	LED yellow

Ambient conditions

Ambient temperature at the installation site of the instrument	-20 ... +60 °C (-4 ... +140 °F) ²⁾
Storage and transport temperature	-40 ... +70 °C (-40 ... +158 °F)
Relative humidity	< 96 %

Electrical protective measures

Protection rating	
– Controller	IP30
– Terminal socket	IP20
Overvoltage category	II
Protection class	II
Measures for electrical separation	reliable separation (VDE 0106, part 1) between power supply, sensor input, level relay and transistor output

Approvals

Depending on the version, instruments with approvals can have different technical data. For these instruments, please note the corresponding approval documents. They are included in the scope of delivery.

²⁾ If several instruments are arranged together in series, the max. ambient temperature is reduced to +50 °C (+122 °F)

9.2 Dimensions

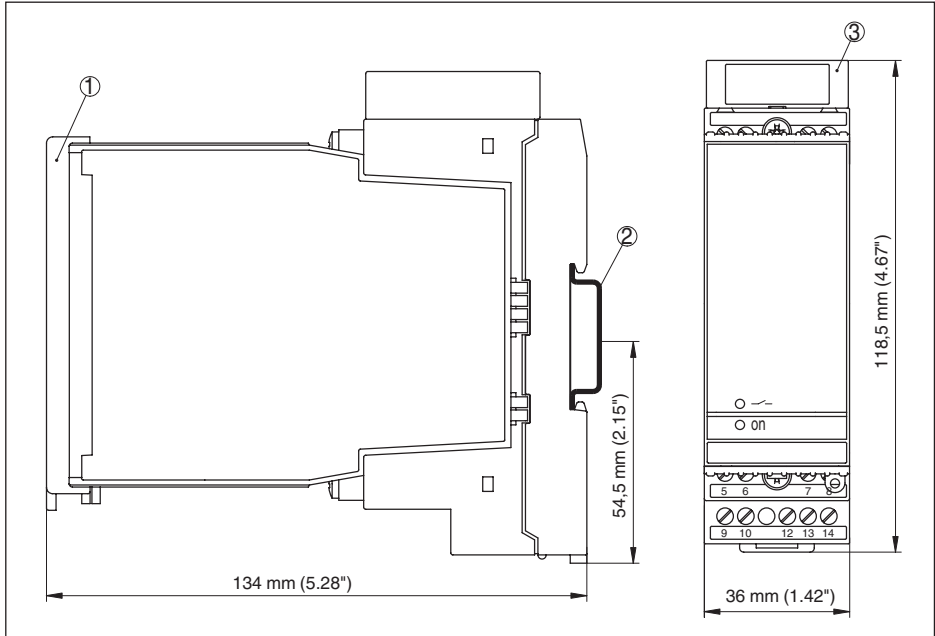

Fig. 9: Dimensions SU 501 Ex

- 1 Transparent cover
- 2 Carrier rail 35 x 7.5 or 35 x 15 according to EN 50022
- 3 Ex separating chamber

9.3 Trademark

All the brands as well as trade and company names used are property of their lawful proprietor/originator.



KROHNE product overview

- Electromagnetic flowmeters
- Variable area flowmeters
- Ultrasonic flowmeters
- Mass flowmeters
- Vortex flowmeters
- Flow controllers
- Level meters
- Temperature assemblies
- Pressure transmitters
- Analysis products
- Products and systems for the oil and gas industry

KROHNE Messtechnik GmbH & Co. KG
Ludwig-Krohne-Straße 5
D-47058 Duisburg
Tel.: +49 (0) 203 301 0
Tel.: +49 (0) 203 301 10389
info@krohne.de

The current list of all KROHNE contacts and addresses can be found at:
www.krohne.com

KROHNE