



## OPTITEMP TT 20 Handbook

Analog PC-programmable two-wire transmitters for Pt100

The documentation is only complete when used in combination with the relevant documentation for the sensor.

All rights reserved. It is prohibited to reproduce this documentation, or any part thereof, without the prior written authorisation of KROHNE Messtechnik GmbH.

Subject to change without notice.

Copyright 2011 by  
KROHNE Messtechnik GmbH - Ludwig-Krohne-Str. 5 - 47058 Duisburg (Germany)

1	Safety instructions	5
<hr/>		
1.1	Intended use .....	5
1.2	Certifications .....	5
1.3	Safety instructions from the manufacturer .....	6
1.3.1	Copyright and data protection .....	6
1.3.2	Disclaimer .....	6
1.3.3	Product liability and warranty .....	7
1.3.4	Information concerning the documentation .....	7
1.3.5	Warnings and symbols used .....	8
1.4	Safety instructions for the operator .....	8
2	Device description	9
<hr/>		
2.1	Scope of delivery .....	9
2.2	Device description .....	9
2.3	Nameplate .....	10
3	Installation	11
<hr/>		
3.1	Notes on installation .....	11
3.2	In-head transmitter .....	11
3.3	Rail mounting kit for in-head transmitters .....	13
4	Electrical connections	15
<hr/>		
4.1	Safety instructions .....	15
4.2	Electrical connection diagram .....	15
4.3	Connection diagram .....	16
5	Operation	17
<hr/>		
5.1	Configuration of transmitter .....	17
5.2	Factory calibration of transmitter .....	18
5.3	Sensor Break Monitoring (Up/Down scale) .....	18
5.4	Sensor Short Circuit (Down Scale) .....	18
5.5	Error Corrections .....	18
6	Service	19
<hr/>		
6.1	Accessory parts .....	19
6.2	Spare parts availability .....	19
6.3	Availability of services .....	19
6.4	Returning the device to the manufacturer .....	19
6.4.1	General information .....	19
6.4.2	Form (for copying) to accompany a returned device .....	20
6.5	Disposal .....	20

7 Technical data	21
<hr/>	
7.1 Measuring principles.....	21
7.1.1 Resistance thermometer.....	21
7.2 Technical data.....	22
7.3 Dimensions.....	25
7.4 Output load diagram.....	25
8 Notes	26
<hr/>	

## 1.1 Intended use

The transmitter is an analog two-wire non-isolating PC configured transmitter designed for Pt100 temperature sensors and intended to be used in an industrial environment.

The transmitter is intended for installation in a B connection head or larger according to DIN 43729. It's designed for a three wire sensor connection.

The transmitters are configured from a PC by using the ConSoft program and a transmitter configuration kit (USB connection) ICON without external power supply. Calibration of the transmitter, after the PC configuration is not necessary.

## 1.2 Certifications

CE marking



**The device fulfils all applicable statutory requirements of the following EC directives:**

- CE Directive 93/68/EEC
- EMC Directive 2004/108/EC according harmonized standard EN 61326-1:2006 including A1 and A2

The manufacturer certifies successful testing of the product by applying the CE marking.

## 1.3 Safety instructions from the manufacturer

### 1.3.1 Copyright and data protection

The contents of this document have been created with great care. Nevertheless, we provide no guarantee that the contents are correct, complete or up-to-date.

The contents and works in this document are subject to copyright. Contributions from third parties are identified as such. Reproduction, processing, dissemination and any type of use beyond what is permitted under copyright requires written authorisation from the respective author and/or the manufacturer.

The manufacturer tries always to observe the copyrights of others, and to draw on works created in-house or works in the public domain.

The collection of personal data (such as names, street addresses or e-mail addresses) in the manufacturer's documents is always on a voluntary basis whenever possible. Whenever feasible, it is always possible to make use of the offerings and services without providing any personal data.

We draw your attention to the fact that data transmission over the Internet (e.g. when communicating by e-mail) may involve gaps in security. It is not possible to protect such data completely against access by third parties.

We hereby expressly prohibit the use of the contact data published as part of our duty to publish an imprint for the purpose of sending us any advertising or informational materials that we have not expressly requested.

### 1.3.2 Disclaimer

The manufacturer will not be liable for any damage of any kind by using its product, including, but not limited to direct, indirect or incidental and consequential damages.

This disclaimer does not apply in case the manufacturer has acted on purpose or with gross negligence. In the event any applicable law does not allow such limitations on implied warranties or the exclusion of limitation of certain damages, you may, if such law applies to you, not be subject to some or all of the above disclaimer, exclusions or limitations.

Any product purchased from the manufacturer is warranted in accordance with the relevant product documentation and our Terms and Conditions of Sale.

The manufacturer reserves the right to alter the content of its documents, including this disclaimer in any way, at any time, for any reason, without prior notification, and will not be liable in any way for possible consequences of such changes.

### 1.3.3 Product liability and warranty

The operator shall bear responsibility for the suitability of the device for the specific purpose. The manufacturer accepts no liability for the consequences of misuse by the operator. Improper installation and operation of the devices (systems) will cause the warranty to be void. The respective "Standard Terms and Conditions" which form the basis for the sales contract shall also apply.

### 1.3.4 Information concerning the documentation

To prevent any injury to the user or damage to the device it is essential that you read the information in this document and observe applicable national standards, safety requirements and accident prevention regulations.

If this document is not in your native language and if you have any problems understanding the text, we advise you to contact your local office for assistance. The manufacturer can not accept responsibility for any damage or injury caused by misunderstanding of the information in this document.

This document is provided to help you establish operating conditions, which will permit safe and efficient use of this device. Special considerations and precautions are also described in the document, which appear in the form of underneath icons.

### 1.3.5 Warnings and symbols used

Safety warnings are indicated by the following symbols.



**DANGER!**

*This information refers to the immediate danger when working with electricity.*



**DANGER!**

*This warning refers to the immediate danger of burns caused by heat or hot surfaces.*



**DANGER!**

*This warning refers to the immediate danger when using this device in a hazardous atmosphere.*



**DANGER!**

*These warnings must be observed without fail. Even partial disregard of this warning can lead to serious health problems and even death. There is also the risk of seriously damaging the device or parts of the operator's plant.*



**WARNING!**

*Disregarding this safety warning, even if only in part, poses the risk of serious health problems. There is also the risk of damaging the device or parts of the operator's plant.*



**CAUTION!**

*Disregarding these instructions can result in damage to the device or to parts of the operator's plant.*



**INFORMATION!**

*These instructions contain important information for the handling of the device.*



**LEGAL NOTICE!**

*This note contains information on statutory directives and standards.*



• **HANDLING**

This symbol designates all instructions for actions to be carried out by the operator in the specified sequence.

➔ **RESULT**

This symbol refers to all important consequences of the previous actions.

## 1.4 Safety instructions for the operator



**WARNING!**

*In general, devices from the manufacturer may only be installed, commissioned, operated and maintained by properly trained and authorized personnel.  
This document is provided to help you establish operating conditions, which will permit safe and efficient use of this device.*



## 2.1 Scope of delivery

**INFORMATION!**

*Inspect the cartons carefully for damages or signs of rough handling. Report damage to the carrier and to the local office of the manufacturer.*

**INFORMATION!**

*Do a check of the packing list to make sure that you have all the elements given in the order.*

**INFORMATION!**

*Look at the device nameplate to ensure that the device is delivered according to your order.*

The scope of delivery always consists of the transmitter and its documentation.

## 2.2 Device description

The transmitter will indicate sensor break according to selected value high ( $> 21.0$  mA) or low ( $< 3.6$  mA). Short circuit will always be indicated as low output ( $< 3.6$  mA).

The transmitter is designed for installation in a B connection head according to DIN 43729. With an installation kit the transmitter can be installed on a top-hat rail according to DIN EN 50022.

The transmitters are configured from a PC by using the ConSoft program and a transmitter configuration kit ICON. When transmitters are configured from PC no calibration is necessary.

The PC configuration software ConSoft is used for configuration, display and documentation. The current ConSoft version is available for downloading on our website.

You can find configuration instructions in the ConSoft reference manual.

ConSoft is compatible with Windows 2000, Windows XP, Windows Vista and Windows 7.

## 2.3 Nameplate



### **INFORMATION!**

Look at the device nameplate to ensure that the device is delivered according to your order.

The transmitter can be identified by the information on the nameplates.

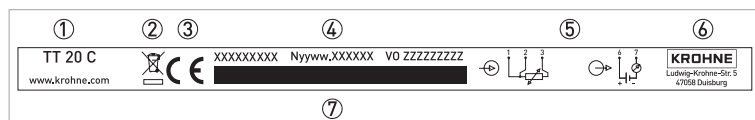

Figure 2-1: Example for round nameplate

- ① Product name
- ② Recycling
- ③ CE marking (EC conformity)
- ④ Part number, serial number and batch number
- ⑤ Connections
- ⑥ Manufacturer and address
- ⑦ Printable field, sensor configuration

### 3.1 Notes on installation



**INFORMATION!**

Inspect the cartons carefully for damages or signs of rough handling. Report damage to the carrier and to the local office of the manufacturer.



**INFORMATION!**

Do a check of the packing list to make sure that you have all the elements given in the order.



**INFORMATION!**

Look at the device nameplate to ensure that the device is delivered according to your order.

### 3.2 In-head transmitter

The transmitter is intended for installation in DIN B connection heads or larger. The large  $\varnothing 7$  mm / 0.28 inch center hole facilitates the electrical connection of the sensor and the installation. For detailed information refer to *Dimensions* on page 25.

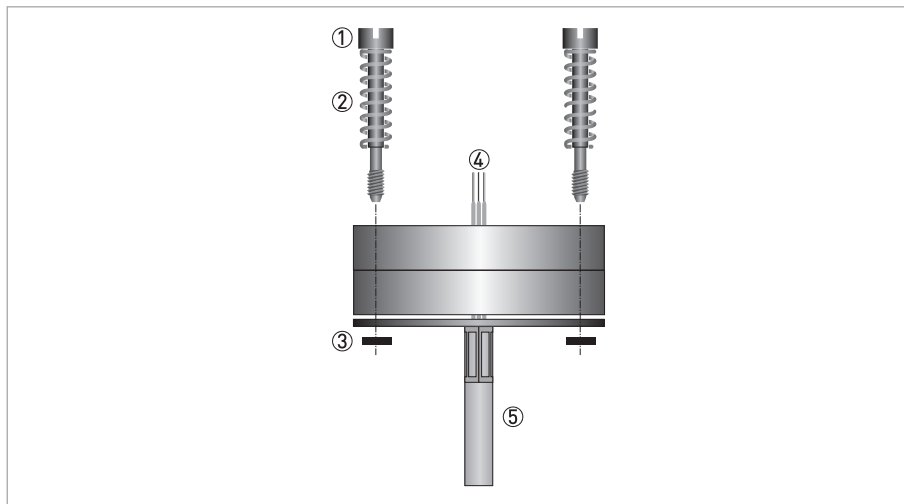

Figure 3-1: Connection head installation kit

- ① M4 screw
- ② Spring
- ③ Lock washer
- ④ Wires from the measuring inserts
- ⑤ MI Cable



**INFORMATION!**

The connection head installation kit does not belong to the standard scope of delivery of the transmitter, you have to order it separately. For more information refer to *Accessory parts* on page 19.

**WARNING!**

*The transmitter has been developed for an operating temperature of  $-40...+85^{\circ}\text{C}$  /  $-40^{\circ}\text{F}...+185^{\circ}\text{F}$ . To avoid destruction or damage of the device, always assure that the operating temperature or ambient temperature does not exceed the permissible range. The thermowell also transfer the process temperature to the transmitter housing. If the process temperature is close to or exceeds the maximum temperature of the transmitter, then the temperature in the transmitter housing can rise above the maximum permissible temperature. One way to decrease the heat transfer via thermowell is to install the transmitter further away from the heat source. Inversely similar measurements can be done if the temperature gets below specified minimum temperature.*

### 3.3 Rail mounting kit for in-head transmitters



#### INFORMATION!

The rail mounting kit allows to install the in-head transmitter on a rail according to DIN 50022. The kit does not belong to the standard scope of delivery. You have to order it separately. For more information refer to Accessory parts on page 19.

The screws in the kit is not to be used with this transmitter.

#### Rail mounting kit for in-head transmitters

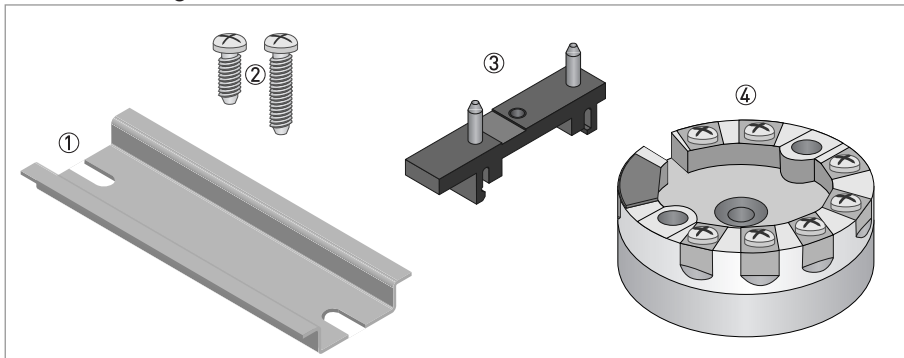
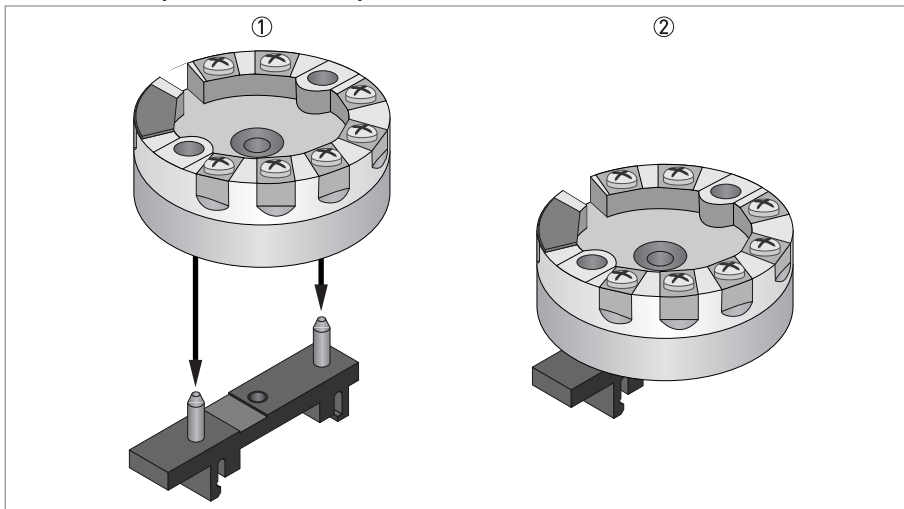

Figure 3-2: Rail mounting kit for in-head transmitters

- ① Rail (not included in the kit)
- ② Screws (not needed)
- ③ Clamp
- ④ Transmitter

#### Installation procedure: Step 1



- ① Place the transmitter on the rail mounting kit as shown above.
- ② Push the transmitter down until it reaches the plate and is attached.

## Installation procedure: Step 2

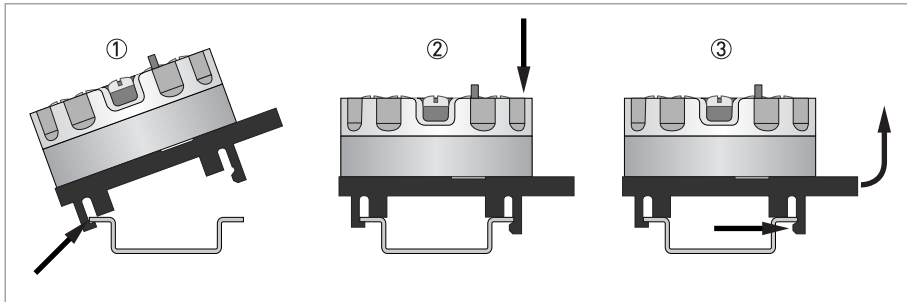

- ① Hook one end of the installation the kit into the rail as shown above.
- ② Push the other end of the the kit down until it snaps onto the rail.
- ③ Release by pushing the hook, shown in the picture, and at the same time lift the clip out of the rail.

## 4.1 Safety instructions



**DANGER!**

All work on the electrical connections may only be carried out with the power disconnected.



**DANGER!**

Observe the corresponding regulations, declarations of conformity, the type test certificate of the device and the relevant instructions of this manual.



**CAUTION!**

Before you connect and operate a transmitter, always note the following items to avoid an electric shock:

- For all work on the electrical connections use an electrostatic safe (i.e. grounded) workplace! In this way you minimize the risk of electrostatic discharge (ESD).



**WARNING!**

Observe without fail the local occupational health and safety regulations. Any work done on the electrical components of the measuring device may only be carried out by properly trained specialists.



**INFORMATION!**

Look at the device nameplate to ensure that the device is delivered according to your order.



**INFORMATION!**

The transmitter is protected against polarity reversal. No damage will occur to the device if the polarity of the supply voltage is switched. The output will then indicate 0 mA.

## 4.2 Electrical connection diagram



**INFORMATION!**

To avoid measuring errors, all cables must be connected properly and the screws tightened correctly.

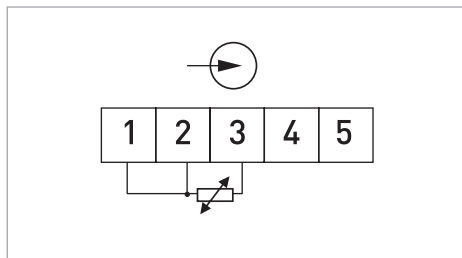

Figure 4-1: Pt100, 3-wire connection



**INFORMATION!**

The transmitter has a polarity protection, connecting the power supply with wrong polarity will not harm the transmitter.

### 4.3 Connection diagram



**CAUTION!**

Always establish the electrical connections according to the following diagrams. Otherwise it can come to destruction or damage of the transmitter. Note that the maximum output load always depends on the power supply. If the maximum output load is exceeded, then the measured value will become incorrect. For further information refer to the output load diagram in the chapter "Technical data" on page 25.

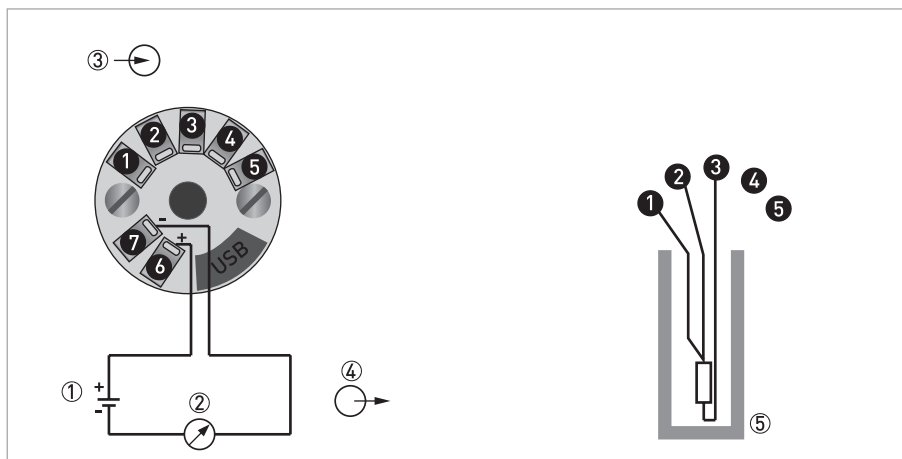

Figure 4-2: Connection diagram

- ① Voltage supply 8.5...32 VDC (terminals 6,7)
- ②  $R_{Load}$
- ③ Input
- ④ Output signal (4...20mA)
- ⑤ Pt100 3-wire connection



## 5.1 Configuration of transmitter

The transmitters are configured from a PC by using the ConSoft program and a transmitter configuration kit ICON. For more information refer to *Accessory parts* on page 19.

The ConSoft is a PC based graphical user interface for configuration of the transmitters. The PC configuration software ConSoft is used for configuration, display and documentation.

Full functionality of the transmitter is achieved with ConSoft program version 2.0.0.1 or later. Consoft is compatible with Windows 2000 SP3, Windows XP (SP2+), Windows Vista, and Windows 7. The current software versions of ConSoft and the USB interface are available for downloading on our website.

Configuration can be performed with or without connected power supply.

To make a configuration of the transmitter you need to do following:



- ① Install the PC configuration software ConSoft in your PC.
- ② Install the driver for the Transmitter configuration kit ICON (included in the Transmitter configuration kit ICON). See User instructions for Transmitter configuration kit ICON. USB interface will indicate correct installation and connection of the transmitter – ICON – PC.
- ③ Connect the transmitter to your PC via the Transmitter configuration kit ICON.
- ④ Start the software ConSoft.
- ⑤ Click on the icon "Read from the transmitter" or File - "Read from the transmitter". The software will identify and connect to the transmitter. A configuration window for the connected transmitter will open.
- ⑥ Enter one of the following options:
  - Temperature sensor - Pt100 type (3 different standards)
  - Measuring range - lower range value and upper range value
  - Error monitoring - upscale or downscale action at sensor break indication
  - Error correction - sensor error lower and upper values - compensation for known sensor errors
  - Custom settings - Tag number
- ⑦ The selected configuration is downloaded to the transmitter by clicking the icon "Transfer to transmitter" or File - "Transfer to transmitter"
- ⑧ The transmitter begins using the new parameters directly after downloading.



**CAUTION!**

*Only use the manufacturer's configuration kit for PC configuration. Another configuration kit could destroy or damage the transmitter.*

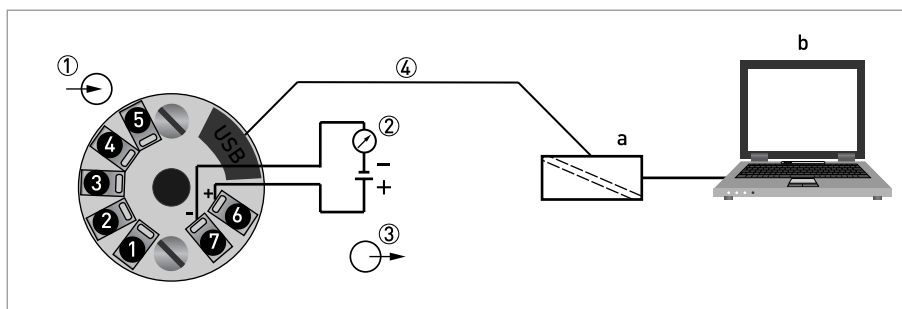

Figure 5-1: Connection during configuration of in-head transmitter

a = PC configuration kit; b = PC software ConSoft

- ① Input
- ②  $R_{Load}$
- ③ Output voltage supply (terminals 6 and 7)
- ④ Communication with USB interface and a PC software ConSoft

## 5.2 Factory calibration of transmitter

The transmitters are delivered with a factory configuration Pt100 ( $\alpha = 0.00385$ ), 3-wire connection 0...+100 °C / +32...+212 °F or configured according to customer's requirements.

Due to the long-term drift of max.  $\pm 0.1\%$  of span per year, a re-calibration of the transmitter is normally not needed. Should you for any reason require the re-calibration, the transmitter must be returned to the factory.

## 5.3 Sensor Break Monitoring (Up/Down scale)

In case the sensor breaks the transmitter will indicate this by either drop the output <3.6 mA or lift it to >21.0 mA. The different indication is set in the transmitter via configurator.

## 5.4 Sensor Short Circuit (Down Scale)

In case the sensor short circuit the transmitter indicates this by dropping the output <3.6 mA and is default.

## 5.5 Error Corrections

By setting the measured min and max value for the sensor in given temperature range the transmitter can compensate sensor errors. This is set with help of the configurator.

## 6.1 Accessory parts

Accessory part	Order code
Universal rail mounting kit for in-head version	70ADA00027
Configuration kit including modem, software Consoft and cables for USB connection	4001107901
Connection Head installation kit	70ADA00017

## 6.2 Spare parts availability

The manufacturer adheres to the basic principle that functionally adequate spare parts for each device or each important accessory part will be kept available for a period of 3 years after delivery of the last production run for the device.

This regulation only applies to spare parts which are subject to wear and tear under normal operating conditions.

## 6.3 Availability of services

The manufacturer offers a range of services to support the customer after expiration of the warranty. These include repair, maintenance, technical support and training.



### **INFORMATION!**

*For more precise information, please contact your local representative.*

## 6.4 Returning the device to the manufacturer

### 6.4.1 General information

This device has been carefully manufactured and tested. If installed and operated in accordance with these operating instructions, it will rarely present any problems.



### **CAUTION!**

*Should you nevertheless need to return a device for inspection or repair, please pay strict attention to the following points:*

- *Due to statutory regulations on environmental protection and safeguarding the health and safety of our personnel, manufacturer may only handle, test and repair returned devices that have been in contact with products without risk to personnel and environment.*
- *This means that the manufacturer can only service this device if it is accompanied by the following certificate (see next section) confirming that the device is safe to handle.*



### **CAUTION!**

*If the device has been operated with toxic, caustic, flammable or water-endangering products, you are kindly requested:*

- *to check and ensure, if necessary by rinsing or neutralizing, that all cavities are free from such dangerous substances,*
- *to enclose a certificate with the device confirming that is safe to handle and stating the product used.*

## 6.4.2 Form (for copying) to accompany a returned device

Company:		Address:	
Department:		Name:	
Tel. no.:		Fax no.:	
Manufacturer's order no. or serial no.:			
The device has been operated with the following medium:			
This medium is:	water-hazardous		
	toxic		
	caustic		
	flammable		
	We checked that all cavities in the device are free from such substances.		
	We have flushed out and neutralized all cavities in the device.		
We hereby confirm that there is no risk to persons or the environment through any residual media contained in the device when it is returned.			
Date:		Signature:	
Stamp:			

## 6.5 Disposal

**CAUTION!**

*Disposal must be carried out in accordance with legislation applicable in your country.*

## 7.1 Measuring principles

The kind of the measuring principle depends on the measuring insert that you combine with the transmitter. In matters of the thermometer type the manufacturer offers two different measuring inserts, either with a resistance thermometer or with a thermocouple. This transmitter only supports resistance thermometer.

### 7.1.1 Resistance thermometer

The measuring insert with a resistance thermometer features a temperature-sensitive sensor made from a platinum RTD, whose value at 0°C / +32°F is 100 Ω. That is where the name "Pt100" comes from.

It is generally valid that the electric resistance of metals increases according to a mathematical function as the temperature rises. This effect is taken advantage of by resistance thermometers to measure temperature. The "Pt100" thermometer features a measuring resistance with defined characteristics, standardised in IEC 60751. The same is true for the tolerances. The average temperature coefficient of a Pt100 is  $3.85 \times 10^{-3} \text{ K}^{-1}$  in the range from 0...+100°C / +32...+212°F.

During operation, a constant current  $I (\leq 1 \text{ mA})$  flows through the Pt100 RTD, which brings about a voltage drop  $U$ . The resistance  $R$  is calculated using Ohm's Law ( $R=U/I$ ). As the voltage drop  $U$  at 0°C / +32°F is 100 mV, the resulting resistance of the Pt100 thermometer is 100 Ω (100 mV / 1 mA = 100 Ω).

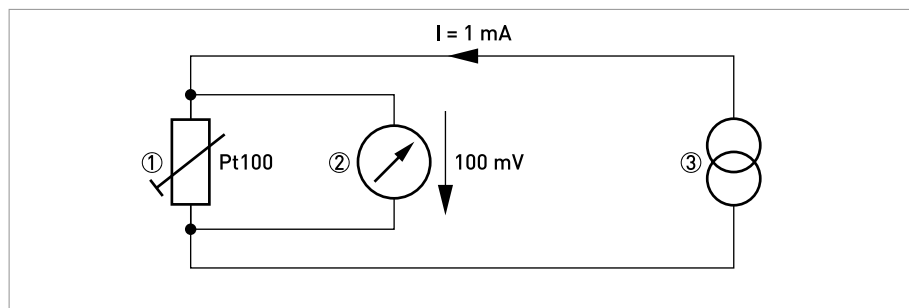

Figure 7-1: Pt100 resistance thermometer in 4-wire connection at 0°C / +32°F, schematic.

- ① Pt100 RTD
- ② Voltage meter
- ③ Current source

## 7.2 Technical data



### INFORMATION!

- The following data is provided for general applications. If you require data that is more relevant to your specific application, please contact us or your local representative.
- Additional information (certificates, special tools, software,...) and complete product documentation can be downloaded free of charge from the website (Download Center).

### Measuring system

Application range	Temperature measurements of solids, liquids and gases in industrial environment.
-------------------	--

### Design

<b>Versions</b>	
TT 20	In-head transmitters which are intended for installation in a "B connection head" or larger according to DIN 43729.
<b>Features</b>	
Sensor matching	A matching to a calibrated temperature sensor can easily be performed by entering the sensor deviation in the low and high ends of the measuring ranges.
PC programmable	Input type and measuring ranges are set from PC.
	Full accuracy is provided without any need for calibration.
	Configuration without external power.
	Edit/Read configuration offline, i.e. without power supply, by just connecting to a USB port of a PC.

### Measuring accuracy

Accuracy & Stability	Basic accuracy is max. of $\pm 0.1\%$ of span.
Temperature influence	Deviation from +20°C / +68°F Max. of $\pm 0.25\%$ / 25°C or $\pm 0.25\%$ / 25°C Max. of $\pm 0.5\%$ / 50°F or $\pm 0.28\%$ / 50°F
Supply voltage influence	Negligible
Long-term drift	$\pm 0.1\%$ of span per year

### Operating conditions

<b>Temperature</b>	
In-head transmitter	<b>Operating and storage temperature:</b> Standard version: -40...+85°C / -40...+185°F
Humidity	0...100% RH (non-condensing)
<b>Protection category</b>	
In-head transmitter	Protection housing: IP65
	Protection terminals: IP10

### Installation conditions

Mounting	In-head transmitter: DIN B-head or larger, DIN-rail (with adapter)
	For detailed information refer to <i>Installation</i> on page 11.
Weight	In-head transmitter: 32 g / 0.07 lb
Dimensions	For detailed information refer to <i>Dimensions</i> on page 25.

**Materials**

Housing	PC/ABS + PA
Flammability acc. to UL	In-head transmitter: V0

**Electrical connections**

Power supply	Standard: 8.5...32 VDC
Isolation	Not galvanically isolated
Connection	Single/stranded wires: max. 1.5 mm <sup>2</sup> / AWG 16
Polarity Protection	Standard

**Inputs / Outputs**

<b>Input - RTD</b>	
Pt100 (IEC 60751, $\alpha=0.00385$ )	-50... +850°C / -58...+1562°F
Pt100 (JIS C 1604-8, $\alpha=0.003916$ )	
Pt100 (US, $\alpha=0,003902$ )	
Sensor current	≤0.5 mA
Maximum sensor wire resistance	20 Ω/wire
Adjustment	Zero adjustment -50, -25, 0, +25, +50°C / -58, -13, +32, +77, +122°F
	Minimum span +20°C / +68°F
	Sensor error compensation ±1% of span
<b>Output</b>	
Output signal	4...20 mA Temperature linear
Permissible load	700 Ω at 24 VDC
NAMUR compliance	Failure currents acc. to NAMUR NE 43 except short circuit detection were downscale is the only option.
Response time	<50 ms
Monitoring	Sensor break monitoring, selectable, upscale ≥21.0 mA or downscale ≤3.6 mA action Sensor short-circuit, fixed, downscale ≤3.6 mA action
<b>Configuration</b>	
ConSoft	The PC configuration software, ConSoft, is a versatile and user-friendly tool for transmitter configuration.
	Consoft is compatible with Windows 2000 (SP3), Windows XP (SP2+), Windows Vista, and Windows 7.
	ConSoft is part of the complete configuration kit ICON, which also contains a USB Interface and necessary cables.

## Approvals and certifications

CE	The device fulfils the statutory requirements of the EC directives. The manufacturer certifies that these requirements have been met by applying the CE marking.
<b>Other standards and approvals</b>	
Electromagnetic compatibility	Directive: 2004/108/EC
	Harmonized standards: EN 61326-1:2006
	ESD, Radiated EM-field: Criteria A Surge: ~3% of span Burst, conducted RF: ~1% of span
Vibration resistance	Acc. to IEC 60068-2-6, test Fc, 84...2000 Hz, 10 g
Shock resistance	Acc. to IEC 60068-2-31, test Ec



## 7.3 Dimensions

### In-head transmitter

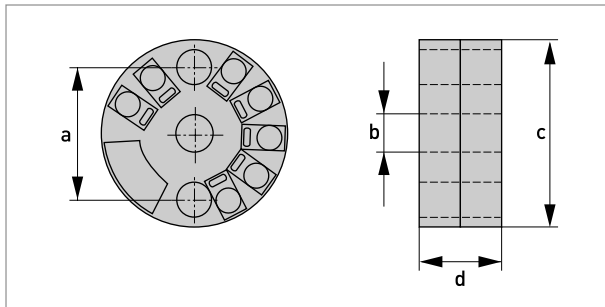

	Dimensions	
	[mm]	[inch]
a	33.0	1.30
b	7.0	0.28
c	44.5	1.75
d	18.5	0.72

## 7.4 Output load diagram

Formula for the maximum permissible output load:

$$\text{permissible } R_{\text{Load}} [\Omega] = (U - 8.5) / 0.022$$

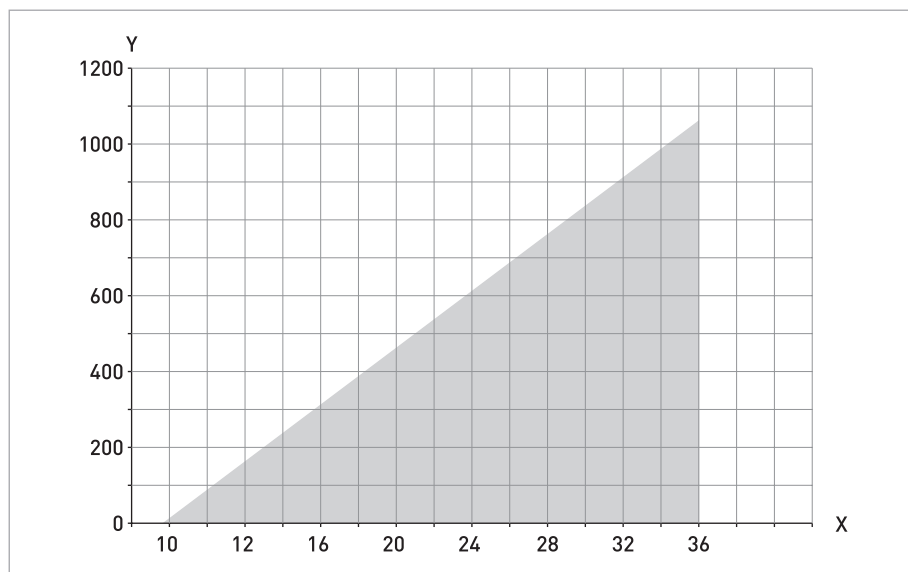

Figure 7-2: Output load diagram

X: Power supply U [VDC]

Y: Total output load R [Ω]







### KROHNE product overview

- Electromagnetic flowmeters
- Variable area flowmeters
- Ultrasonic flowmeters
- Mass flowmeters
- Vortex flowmeters
- Flow controllers
- Level meters
- Temperature meters
- Pressure meters
- Analysis products
- Measuring systems for the oil and gas industry
- Measuring systems for sea-going tankers

Head Office KROHNE Messtechnik GmbH  
Ludwig-Krohne-Str. 5  
D-47058 Duisburg (Germany)  
Tel.: +49 (0)203 301 0  
Fax: +49 (0)203 301 10389  
info@krohne.de

The current list of all KROHNE contacts and addresses can be found at:  
[www.krohne.com](http://www.krohne.com)

**KROHNE**