



PTD 600 Handbook

Piezoresistive pressure transmitter with flush membrane

All rights reserved. It is prohibited to reproduce this documentation, or any part thereof, without the prior written authorisation of KROHNE Messtechnik GmbH.

Subject to change without notice.

Copyright 2012 by
KROHNE Messtechnik GmbH - Ludwig-Krohne-Str. 5 - 47058 Duisburg (Germany)

| | | |
|-------|---|----|
| 1 | Safety instructions | 5 |
| <hr/> | | |
| 1.1 | Intended use | 5 |
| 1.2 | Safety instructions from the manufacturer | 5 |
| 1.2.1 | Copyright and data protection | 5 |
| 1.2.2 | Disclaimer | 6 |
| 1.2.3 | Product liability and warranty | 6 |
| 1.2.4 | Information concerning the documentation | 6 |
| 1.2.5 | Warnings and symbols used | 7 |
| 1.3 | Safety instructions for the operator | 7 |
| 2 | Device description | 8 |
| <hr/> | | |
| 2.1 | Scope of delivery | 8 |
| 2.2 | Nameplate | 8 |
| 3 | Installation | 9 |
| <hr/> | | |
| 3.1 | Notes on installation | 9 |
| 3.2 | Installation specifications | 9 |
| 3.3 | Mounting to pressure system | 9 |
| 3.4 | Hygiene | 10 |
| 4 | Electrical connections | 11 |
| <hr/> | | |
| 4.1 | Safety instructions | 11 |
| 4.2 | Terminal assignment | 11 |
| 4.3 | Electrical connection diagram | 12 |
| 5 | Operation | 13 |
| <hr/> | | |
| 5.1 | Start-up | 13 |
| 5.2 | Configuration tool | 13 |
| 6 | Service | 14 |
| <hr/> | | |
| 6.1 | Spare parts availability | 14 |
| 6.2 | Availability of services | 14 |
| 6.3 | Repairs | 14 |
| 6.4 | Accessories | 14 |
| 6.5 | Returning the device to the manufacturer | 15 |
| 6.5.1 | General information | 15 |
| 6.5.2 | Form (for copying) to accompany a returned device | 16 |
| 6.6 | Disposal | 16 |

| | |
|----------------------------------|----|
| 7 Technical data | 17 |
| 7.1 Technical data..... | 17 |
| 7.2 Dimensions and weights | 19 |
| 7.3 Pressure resistance | 21 |
| 8 Notes | 22 |

1.1 Intended use

**CAUTION!**

Responsibility for the use of the measuring devices with regard to suitability, intended use and corrosion resistance of the used materials against the measured fluid lies solely with the operator.

**INFORMATION!**

The manufacturer is not liable for any damage resulting from improper use or use for other than the intended purpose.

The **PTD 600** pressure transmitter is designed to measure the absolute pressure and gauge pressure of gases, vapours and liquids. As an option, it can also measure the hydrostatic level.

1.2 Safety instructions from the manufacturer

1.2.1 Copyright and data protection

The contents of this document have been created with great care. Nevertheless, we provide no guarantee that the contents are correct, complete or up-to-date.

The contents and works in this document are subject to copyright. Contributions from third parties are identified as such. Reproduction, processing, dissemination and any type of use beyond what is permitted under copyright requires written authorisation from the respective author and/or the manufacturer.

The manufacturer tries always to observe the copyrights of others, and to draw on works created in-house or works in the public domain.

The collection of personal data (such as names, street addresses or e-mail addresses) in the manufacturer's documents is always on a voluntary basis whenever possible. Whenever feasible, it is always possible to make use of the offerings and services without providing any personal data.

We draw your attention to the fact that data transmission over the Internet (e.g. when communicating by e-mail) may involve gaps in security. It is not possible to protect such data completely against access by third parties.

We hereby expressly prohibit the use of the contact data published as part of our duty to publish an imprint for the purpose of sending us any advertising or informational materials that we have not expressly requested.

1.2.2 Disclaimer

The manufacturer will not be liable for any damage of any kind by using its product, including, but not limited to direct, indirect or incidental and consequential damages.

This disclaimer does not apply in case the manufacturer has acted on purpose or with gross negligence. In the event any applicable law does not allow such limitations on implied warranties or the exclusion of limitation of certain damages, you may, if such law applies to you, not be subject to some or all of the above disclaimer, exclusions or limitations.

Any product purchased from the manufacturer is warranted in accordance with the relevant product documentation and our Terms and Conditions of Sale.

The manufacturer reserves the right to alter the content of its documents, including this disclaimer in any way, at any time, for any reason, without prior notification, and will not be liable in any way for possible consequences of such changes.

1.2.3 Product liability and warranty

The operator shall bear responsibility for the suitability of the device for the specific purpose. The manufacturer accepts no liability for the consequences of misuse by the operator. Improper installation and operation of the devices (systems) will cause the warranty to be void. The respective "Standard Terms and Conditions" which form the basis for the sales contract shall also apply.

1.2.4 Information concerning the documentation

To prevent any injury to the user or damage to the device it is essential that you read the information in this document and observe applicable national standards, safety requirements and accident prevention regulations.

If this document is not in your native language and if you have any problems understanding the text, we advise you to contact your local office for assistance. The manufacturer can not accept responsibility for any damage or injury caused by misunderstanding of the information in this document.

This document is provided to help you establish operating conditions, which will permit safe and efficient use of this device. Special considerations and precautions are also described in the document, which appear in the form of underneath icons.

1.2.5 Warnings and symbols used

Safety warnings are indicated by the following symbols.



DANGER!

This information refers to the immediate danger when working with electricity.



DANGER!

This warning refers to the immediate danger of burns caused by heat or hot surfaces.



DANGER!

This warning refers to the immediate danger when using this device in a hazardous atmosphere.



DANGER!

These warnings must be observed without fail. Even partial disregard of this warning can lead to serious health problems and even death. There is also the risk of seriously damaging the device or parts of the operator's plant.



WARNING!

Disregarding this safety warning, even if only in part, poses the risk of serious health problems. There is also the risk of damaging the device or parts of the operator's plant.



CAUTION!

Disregarding these instructions can result in damage to the device or to parts of the operator's plant.



INFORMATION!

These instructions contain important information for the handling of the device.



LEGAL NOTICE!

This note contains information on statutory directives and standards.



• **HANDLING**

This symbol designates all instructions for actions to be carried out by the operator in the specified sequence.

➔ **RESULT**

This symbol refers to all important consequences of the previous actions.

1.3 Safety instructions for the operator



WARNING!

*In general, devices from the manufacturer may only be installed, commissioned, operated and maintained by properly trained and authorized personnel.
This document is provided to help you establish operating conditions, which will permit safe and efficient use of this device.*

2.1 Scope of delivery

The following items are supplied with the device:

- Measuring device in ordered version
- Product documentation

2.2 Nameplate



INFORMATION!

Look at the device nameplate to ensure that the device is delivered according to your order. Check for the correct supply voltage printed on the nameplate.

The important technical values are engraved on the device body.

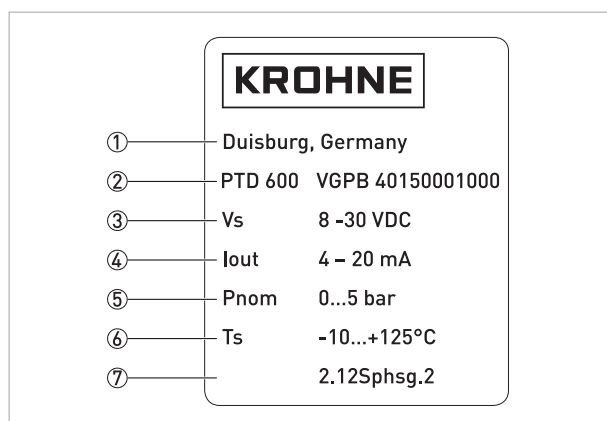

Figure 2-1: Example of engraved values on the nameplate

- ① Manufacturer
- ② Device designation and order code
- ③ Supply voltage
- ④ Output signal
- ⑤ Measuring range
- ⑥ Temperature range
- ⑦ Serial number

3.1 Notes on installation



INFORMATION!

Inspect the cartons carefully for damages or signs of rough handling. Report damage to the carrier and to the local office of the manufacturer.



INFORMATION!

Do a check of the packing list to make sure that you have all the elements given in the order.



INFORMATION!

Look at the device nameplate to ensure that the device is delivered according to your order. Check for the correct supply voltage printed on the nameplate.

3.2 Installation specifications

Even though its design is robust, the pressure transmitter should not be exposed to any heavy impact. Avoid high static and dynamic pressures that exceed the values indicated in "Technical data".

In the case of flush connections, there is one wavy, highly sensitive membrane exposed. To avoid damaging the membrane, do not use abrasive cleaning agents or allow it to come into contact with hard bodies (including fingers) or tools. The protective cover should thus only be removed immediately before installing the transmitter.

3.3 Mounting to pressure system

Versions with thread connection

- The pressure transmitter features a male thread for the connection.
- If the seal is metallic, it is recommended to grease the raised face with a MoS₂ or Vaseline-based lubricant.
- Use a suitable wrench for mounting. Do not exceed the tightening torque when mounting (refer to the table below).

| Process connection | Tightening torques [Nm] at a pressure of | |
|--------------------|--|---|
| | ≤ 1 bar / 14.5 psi | 1 bar / 14.5 psi > p ≤ 40 bar / 580 psi |
| G½ | 10 | 15 |
| G1 | | 40 |

Versions with hygienic clamp connection

- The pressure transmitter features appropriate hygienic clamp connections for the connection.
- Only use clamp connections designed for the specific application and pressure.
- Do not damage the seal during installation or replacement.

Versions with cooling neck

To ensure proper cooling function, versions with cooling neck ($T_{\text{Medium}} \leq 200^{\circ}\text{C} / 392^{\circ}\text{F}$) must be installed at a maximum 10° angle to the horizontal.

3.4 Hygiene

- The mounting position, connection piece and sealing point should be designed so that the system is completely self-draining and there are no hollow spaces.
- The transmitters are designed for CIP and SIP:
 $T_{\text{max}} = 150^{\circ}\text{C} / 302^{\circ}\text{F} < 60$ minutes for hygienic process connections;
 $T_{\text{max}} = 125^{\circ}\text{C} / 257^{\circ}\text{F}$ for devices with thread connection
- It is not possible to sterilise the entire transmitter without protective devices in place.

4.1 Safety instructions



DANGER!

All work on the electrical connections may only be carried out with the power disconnected. Take note of the voltage data on the nameplate!



DANGER!

Observe the national regulations for electrical installations!



WARNING!

Observe without fail the local occupational health and safety regulations. Any work done on the electrical components of the measuring device may only be carried out by properly trained specialists.



INFORMATION!

Look at the device nameplate to ensure that the device is delivered according to your order. Check for the correct supply voltage printed on the nameplate.

4.2 Terminal assignment

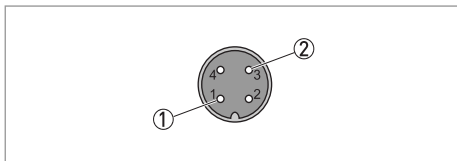

Figure 4-1: Terminal assignment for 4-pin M12 plug

- ① +V_S (supply voltage)
- ② I_{Out}/GND (current output)

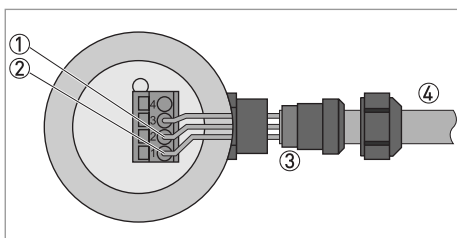

Figure 4-2: Terminal assignment for field housing

- ① I_{Out}/GND (current output)
- ② +V_S (supply voltage)
- ③ Shielding
- ④ Cable diameter: 8...10 mm / 0.3...0.4" (cable not included in delivery)

4.3 Electrical connection diagram



DANGER!

- Check polarity and use shielded cables.
- The transmitter housing and shield must be grounded.
- Place the shielding on the control side to ground across a large area to ensure the best possible protection against electromagnetic interference.
For field housing versions, place the shield evenly on the contact surface of the cable feedthrough.
- Avoid potential differences between the transmitter housing and the control if at all possible. To comply fully with PELV requirements in accordance with EN 60204-1 §6.4.1, connect 0 V (ground) to a point in the system with protective earth.

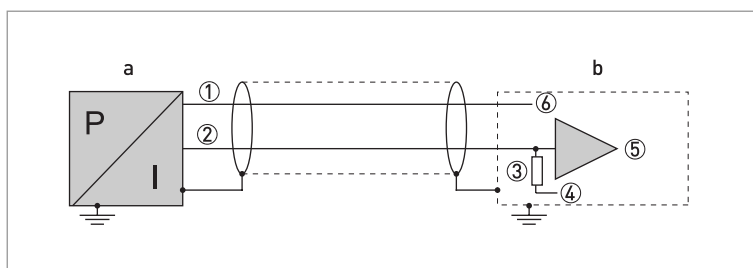

Figure 4-3: Electrical connection diagram

a: pressure transmitter

b: power supply / measuring unit

- ① +V_S (supply voltage)
- ② I_{O_{ut}}/GND (current output)
- ③ R_{Load}
- ④ Ground
- ⑤ Measurement
- ⑥ Operating voltage

5.1 Start-up

Before connecting to power, please check that the system has been correctly installed. This includes:

- The device must be mechanically safe and mounted in compliance with the regulations.
- Check the leak-tightness of the process connection.
- Make sure that the M12 plug is properly connected.
- The power connections must have been made in compliance with the regulations.
- Check that the electrical operating data of the power supply are correct.



- Switching on the power.

5.2 Configuration tool

The configuration tool (order number XGP9000010) can be ordered optionally to configure the pressure transmitter.

Scope of delivery:

- Interface unit
- CD with software and product drivers (DTM)
- USB cable
- Cable with M12 connector

The configuration tool connects the transmitter to a computer. With the proper software, an online connection to the pressure transmitter can be established.

When using this tool, device information including the serial number and measuring point numbers are displayed on the computer. Settings including the zero point, measuring range, signal limits and others can be configured.

There is also a reset function to return to the default values.



DANGER!

Disconnect the power supply before connecting the configuration tool to the transmitter!

6.1 Spare parts availability

The manufacturer adheres to the basic principle that functionally adequate spare parts for each device or each important accessory part will be kept available for a period of 3 years after delivery of the last production run for the device.

This regulation only applies to spare parts which are subject to wear and tear under normal operating conditions.

6.2 Availability of services

The manufacturer offers a range of services to support the customer after expiration of the warranty. These include repair, maintenance, technical support and training.



INFORMATION!

For more precise information, please contact your local representative.

6.3 Repairs

Repairs may be carried out exclusively by the manufacturer or the manufacturer authorised specialist companies.

6.4 Accessories

| Designation | Type | Order code |
|---|---------|--------------|
| Welded sleeve | HWN 500 | VGP7 4001000 |
| Varivent flange version N | HVF 550 | VGP7 400C000 |
| Dairy pipe installation set DN50 | HMM 550 | VGP7 400B000 |
| Tri-Clamp flange 2", DN50 DIN 32676 | HTC 500 | VGP7 400D000 |
| Tri-Clamp flange 1½", DN40 DIN 32676 | HTC 540 | VGP7 400V000 |
| Configuration tool | - | XGP 900010 |



INFORMATION!

Other hygienic connections are available on request.

6.5 Returning the device to the manufacturer

6.5.1 General information

This device has been carefully manufactured and tested. If installed and operated in accordance with these operating instructions, it will rarely present any problems.



CAUTION!

Should you nevertheless need to return a device for inspection or repair, please pay strict attention to the following points:

- *Due to statutory regulations on environmental protection and safeguarding the health and safety of our personnel, manufacturer may only handle, test and repair returned devices that have been in contact with products without risk to personnel and environment.*
- *This means that the manufacturer can only service this device if it is accompanied by the following certificate (see next section) confirming that the device is safe to handle.*



CAUTION!

If the device has been operated with toxic, caustic, flammable or water-endangering products, you are kindly requested:

- *to check and ensure, if necessary by rinsing or neutralizing, that all cavities are free from such dangerous substances,*
- *to enclose a certificate with the device confirming that is safe to handle and stating the product used.*

6.5.2 Form (for copying) to accompany a returned device

| | | | |
|---|---|------------|--|
| Company: | | Address: | |
| Department: | | Name: | |
| Tel. no.: | | Fax no.: | |
| Manufacturer's order no. or serial no.: | | | |
| The device has been operated with the following medium: | | | |
| This medium is: | water-hazardous | | |
| | toxic | | |
| | caustic | | |
| | flammable | | |
| | We checked that all cavities in the device are free from such substances. | | |
| | We have flushed out and neutralized all cavities in the device. | | |
| We hereby confirm that there is no risk to persons or the environment through any residual media contained in the device when it is returned. | | | |
| Date: | | Signature: | |
| Stamp: | | | |

6.6 Disposal

**CAUTION!**

Disposal must be carried out in accordance with legislation applicable in your country.

7.1 Technical data



INFORMATION!

- The following data is provided for general applications. If you require data that is more relevant to your specific application, please contact us or your local representative.
- Additional information (certificates, special tools, software,...) and complete product documentation can be downloaded free of charge from the website (Download Center).

Measuring system

| | |
|---------------------|---|
| Measuring principle | Piezoresistive silicon sensor |
| Application range | Hydrostatic level detection as well as pressure measurement in pipelines for gas, steam and liquids |
| Measuring range | -1...40 bar / -14.5...580 psi |

Measuring accuracy

| | |
|--------------------------|---|
| Reference conditions | Medium: air |
| | Temperature: +20°C / +68°F |
| Pressure type | Gauge pressure / absolute pressure |
| Measuring accuracy | 0.5%, 0.25% or 0.1% of the full scale (including linearity, hysteresis and repeatability) |
| Deviation of zero point | ≤±0.03% of the full scale/10 K |
| Deviation of span | ≤±0.03% of the full scale/10 K |
| Long-term stability | 0.1% of the full scale/ year |
| Response time (10...90%) | 5 ms |

Operating conditions

| | |
|--|--|
| Temperature | |
| Process temperature | Standard: -10...+125°C / +14...+257°F |
| | With optional cooling neck: -10...+200°C / +14...+392°F |
| CIP/SIP | Max. up to 150°C / 302°F < 60 minutes for hygienic process connections |
| | Max. up to 125°C / 257°F for devices with thread connection |
| Ambient temperature | -10...+85°C / +14...+185°F |
| Storage temperature | -10...+85°C / +14...+185°F |
| Other conditions | |
| Protection category acc. to IEC 529 / EN 60529 | IP67 |

Installation conditions

| | |
|------------------------|--|
| Installation | Can be installed in any position, zero point or position correction may be required following installation. |
| | To ensure proper cooling function, versions with cooling neck ($T_{\text{Medium}} \leq 200^\circ\text{C} / 392^\circ\text{F}$) must be installed at a maximum 10° angle to the horizontal. |
| Dimensions and weights | For detailed information refer to section "Dimensions and weights". |

Materials

| | |
|--------------------|---|
| Sensor housing | Stainless steel 1.4404 / 316L or Hastelloy® C |
| Process connection | Stainless steel 1.4404 / 316L or Hastelloy® C |

Process connections

| | |
|----------|--|
| Standard | G1 connection with flush hygienic cone in combination with hygienic process connection adapters like the Tri-Clamp, 11851, Varivent (see the "Accessories" data sheet for details) |
| Optional | G½ with flush hygienic cone |
| | DN40/DN50 clamp acc. to DIN 32676 |
| | 38/51 mm clamp ISO 2852 |
| | 1½" Tri-Clamp and GEA Tuchenhausen type N connection |

Electrical connection

| | |
|-----------------------|---|
| Power supply | 8...30 VDC |
| Load resistance | $R_{Load} [\Omega] = (U_{Supply} [V] - 8 V) / 20 [mA]$ |
| Output signal | 4...20 mA |
| Insulation resistance | >100 MΩ at 750 V |
| Cable feedthroughs | Compact housing: M12 plug made of stainless steel (1.4404 / 316L) |
| | Field housing: M16 made of stainless steel (1.4404 / 316L) |

Approvals and certificates

| | |
|--|--|
| CE | The device fulfils the statutory requirements of the EC directives. The manufacturer certifies that these requirements have been met by applying the CE marking. |
| Electromagnetic compatibility (EMC) | 2004/108/EC in accordance with EN 61000-6-2 and EN 61000-6-3 |
| Pressure equipment directive | 97/23/EC |
| Other standards and approvals | |
| Vibration according to IEC 60068-2-6 | 1.5 mm (10...55 Hz), 10 g (58 Hz...2 KHz), 10 cycles within 2.5 h per axis |
| Shock test in accordance with IEC 60068-2-27 | 50 g/11 ms, 100 g/6 ms, 10 x pulse/axis and direction |
| Bump in accordance with IEC 60068-2-29 | 100 g/2 ms, 4000 x pulse/axis and direction |
| Statistical failures in accordance with IEC 60068-2-64 | 0.1 g ² /Hz (20 Hz...1 KHz), 30 min. per axis (>10 g RMS) |
| Hygiene | FDA approved materials |

7.2 Dimensions and weights

Hygienic process connections

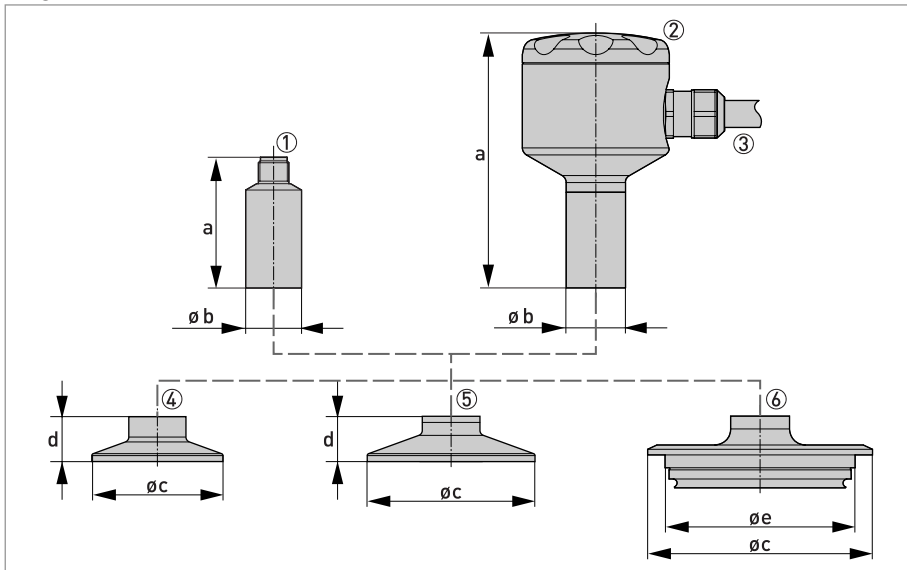

Figure 7-1: Dimensions for pressure transmitter with hygienic connections

- ① Compact housing with M12 plug
- ② Field housing with M16 cable feedthroughs
- ③ Max. cable diameter: $\varnothing 8...10$ mm / $\varnothing 0.3...0.4$ "
- ④ DN38 ISO 2852 / Tri-Clamp 1½", DN38 DIN 32676 clamp 3A
- ⑤ DN51 ISO 2852 / DIN 32676 clamp 3A
- ⑥ GEA Tuchenhagen type N connection

| | Dimensions | | | | | | | | | |
|---|------------------|-------------------|------------------|-------------------|--------------------|-----------------|------------------|-------------------|------------------|-------------------|
| | ① | | ② | | ④ | | ⑤ | | ⑥ | |
| | [mm] | ["] | [mm] | ["] | [mm] | ["] | [mm] | ["] | [mm] | ["] |
| a | 51.6 | 2 | 94.5 | 3.7 | - | - | - | - | - | - |
| b | $\varnothing 22$ | $\varnothing 0.9$ | $\varnothing 22$ | $\varnothing 0.9$ | - | - | - | - | - | - |
| c | - | - | - | - | $\varnothing 50.5$ | $\varnothing 2$ | $\varnothing 64$ | $\varnothing 2.5$ | $\varnothing 84$ | $\varnothing 3.3$ |
| d | - | - | - | - | 17.3 | 0.7 | 17.3 | 0.7 | - | - |
| e | - | - | - | - | - | - | - | - | $\varnothing 68$ | $\varnothing 2.7$ |

Weight for compact housing: approx. 150 g / 0.33 lbs

Weight field housing: approx. 600 g / 1.32 lbs

Thread with flush hygienic cone

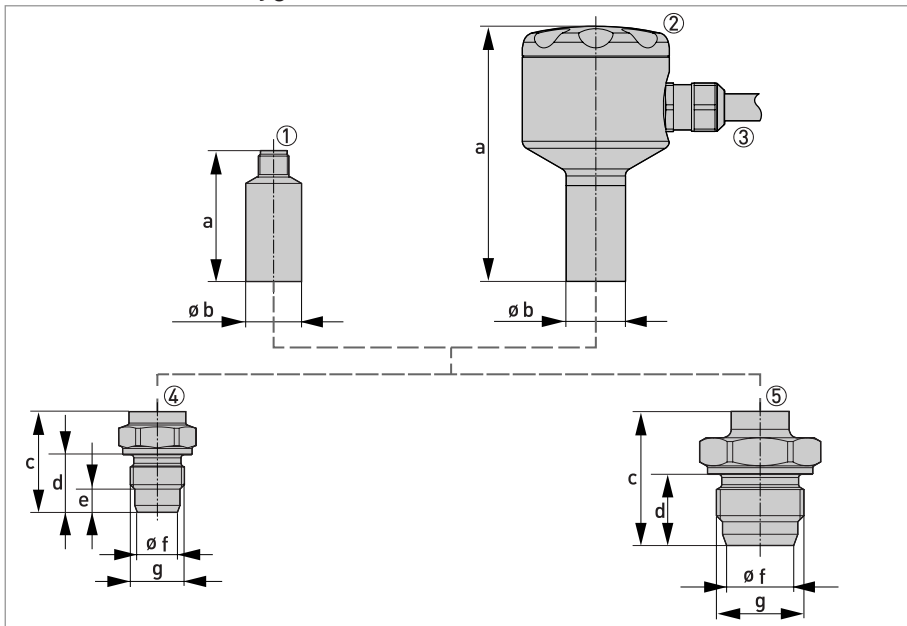

Figure 7-2: Dimensions for pressure transmitter with thread and flush hygienic cone

- ① Compact housing with M12 plug
- ② Field housing with M16 cable feedthrough
- ③ Max. cable diameter: Ø8...10 mm / Ø0.3...0.4"
- ④ G½
- ⑤ G1

| | Dimensions | | | | | | | |
|---|------------|------|------|------|-------|------|-------|-----|
| | ① | | ② | | ④ | | ⑤ | |
| | [mm] | ["] | [mm] | ["] | [mm] | ["] | [mm] | ["] |
| a | 51.6 | 2 | 94.5 | 3.7 | - | - | - | - |
| b | Ø22 | Ø0.9 | Ø22 | Ø0.9 | - | - | - | - |
| c | - | - | - | - | 39 | 1.5 | 51 | 2 |
| d | - | - | - | - | 22.3 | 0.9 | 27 | 1.1 |
| e | - | - | - | - | 9 | - | - | - |
| f | - | - | - | - | Ø15.5 | Ø0.6 | Ø25.5 | Ø1 |
| g | - | - | - | - | G½ | | G1 | |

Weight compact housing: approx. 130 g / 0.29 lbs

Weight field housing: approx. 570 g / 1.26 lbs



INFORMATION!

All thread connections can be made into hygienic versions by using the hygienic process connection adapters. See the "Accessories" data sheet for details.

7.3 Pressure resistance

| | Pressure in bar | | | | | | |
|----------------|-----------------|-------------|----------|----------|---------|---------|---------|
| Pressure range | -0.1...0.1 | -0.2...+0.2 | 0...1 | 0...1.6 | 0...6 | 0...25 | 0...40 |
| | 0...0.1 | 0...0.4 | -1...0 | 0...2 | 0...10 | 0...20 | -1...39 |
| | 0...0.16 | 0...0.6 | -1...0.6 | 0...2.5 | -1...9 | -1...24 | |
| | 0...0.25 | | | -1...1.5 | 0...16 | | |
| | | | | 0...4 | -1...15 | | |
| | | | | -1...3 | | | |
| -1...5 | | | | | | | |
| Over pressure | 1 | 3 | 3 | 15 | 60 | 70 | 135 |
| Burst pressure | 2 | 6 | 6 | 30 | 120 | 140 | 270 |







KROHNE product overview

- Electromagnetic flowmeters
- Variable area flowmeters
- Ultrasonic flowmeters
- Mass flowmeters
- Vortex flowmeters
- Flow controllers
- Level meters
- Temperature meters
- Pressure meters
- Analysis products
- Products and systems for the oil & gas industry
- Measuring systems for the marine industry

Head Office KROHNE Messtechnik GmbH
Ludwig-Krohne-Str. 5
47058 Duisburg (Germany)
Tel.: +49 (0)203 301 0
Fax: +49 (0)203 301 10389
info@krohne.de

The current list of all KROHNE contacts and addresses can be found at:
www.krohne.com

KROHNE