



SENSOFIT FLOW Handbook

Flow assembly

All rights reserved. It is prohibited to reproduce this documentation, or any part thereof, without the prior written authorisation of KROHNE Messtechnik GmbH.

Subject to change without notice.

Copyright 2016 by
KROHNE Messtechnik GmbH - Ludwig-Krohne-Str. 5 - 47058 Duisburg (Germany)

1	Safety instructions	4
1.1	Intended use	4
1.2	Certifications	4
1.3	Safety instructions from the manufacturer	5
1.3.1	Copyright and data protection	5
1.3.2	Disclaimer	5
1.3.3	Product liability and warranty	6
1.3.4	Information concerning the documentation	6
1.3.5	Warnings and symbols used	7
1.4	Safety instructions for the operator	7
2	Device description	8
2.1	Scope of delivery	8
2.2	Device description	9
2.3	Nameplate	9
3	Installation	10
3.1	General notes on installation	10
3.2	Storage and transport	10
3.3	Pre-installation requirements	10
3.4	Installing the assembly	11
4	Service	12
4.1	Maintenance	12
4.1.1	Availability of services	12
4.1.2	Spare parts availability	12
4.1.3	Service instructions	12
4.2	Returning the device to the manufacturer	13
4.2.1	General information	13
4.2.2	Form (for copying) to accompany a returned device	14
4.3	Disposal	14
5	Technical data	15
5.1	Technical data	15
5.2	Dimensions	16
6	Notes	18

1.1 Intended use

**CAUTION!**

Responsibility for the use of the measuring devices with regard to suitability, intended use and corrosion resistance of the used materials against the measured fluid lies solely with the operator.

**INFORMATION!**

The manufacturer is not liable for any damage resulting from improper use or use for other than the intended purpose.

The flow-through assembly SENSOFIT FLOW 1710 is built in pipes. The flow-through assembly serves for mounting a sensor in such a way that it immerses into the process fluid in order to measure chemical or physical characteristics. If the sensor cannot be installed in the flow through assembly directly, an insertion assembly can be used as a connector. The material characteristics of the flow-through assembly, the gaskets, the sensors and the housing must be chosen depending on the process characteristics (e.g. pressure, temperature, abrasivity). The flow-through assembly must be maintained on a regular basis. Establish a maintenance plan which is adjusted to your process.

1.2 Certifications

CE marking



The device fulfils the statutory requirements of the following EC directives:

- Directive 97/23/EC on Pressure Equipment

The manufacturer certifies successful testing of the product by applying the CE marking.

1.3 Safety instructions from the manufacturer

1.3.1 Copyright and data protection

The contents of this document have been created with great care. Nevertheless, we provide no guarantee that the contents are correct, complete or up-to-date.

The contents and works in this document are subject to copyright. Contributions from third parties are identified as such. Reproduction, processing, dissemination and any type of use beyond what is permitted under copyright requires written authorisation from the respective author and/or the manufacturer.

The manufacturer tries always to observe the copyrights of others, and to draw on works created in-house or works in the public domain.

The collection of personal data (such as names, street addresses or e-mail addresses) in the manufacturer's documents is always on a voluntary basis whenever possible. Whenever feasible, it is always possible to make use of the offerings and services without providing any personal data.

We draw your attention to the fact that data transmission over the Internet (e.g. when communicating by e-mail) may involve gaps in security. It is not possible to protect such data completely against access by third parties.

We hereby expressly prohibit the use of the contact data published as part of our duty to publish an imprint for the purpose of sending us any advertising or informational materials that we have not expressly requested.

1.3.2 Disclaimer

The manufacturer will not be liable for any damage of any kind by using its product, including, but not limited to direct, indirect or incidental and consequential damages.

This disclaimer does not apply in case the manufacturer has acted on purpose or with gross negligence. In the event any applicable law does not allow such limitations on implied warranties or the exclusion of limitation of certain damages, you may, if such law applies to you, not be subject to some or all of the above disclaimer, exclusions or limitations.

Any product purchased from the manufacturer is warranted in accordance with the relevant product documentation and our Terms and Conditions of Sale.

The manufacturer reserves the right to alter the content of its documents, including this disclaimer in any way, at any time, for any reason, without prior notification, and will not be liable in any way for possible consequences of such changes.

1.3.3 Product liability and warranty

The operator shall bear responsibility for the suitability of the device for the specific purpose. The manufacturer accepts no liability for the consequences of misuse by the operator. Improper installation or operation of the devices (systems) will cause the warranty to be void. The respective "Standard Terms and Conditions" which form the basis for the sales contract shall also apply.

1.3.4 Information concerning the documentation

To prevent any injury to the user or damage to the device it is essential that you read the information in this document and observe applicable national standards, safety requirements and accident prevention regulations.

If this document is not in your native language and if you have any problems understanding the text, we advise you to contact your local office for assistance. The manufacturer can not accept responsibility for any damage or injury caused by misunderstanding of the information in this document.

This document is provided to help you establish operating conditions, which will permit safe and efficient use of this device. Special considerations and precautions are also described in the document, which appear in the form of icons as shown below.

1.3.5 Warnings and symbols used

Safety warnings are indicated by the following symbols.



DANGER!

This warning refers to the immediate danger when working with electricity.



DANGER!

This warning refers to the immediate danger of burns caused by heat or hot surfaces.



DANGER!

This warning refers to the immediate danger when using this device in a hazardous atmosphere.



DANGER!

These warnings must be observed without fail. Even partial disregard of this warning can lead to serious health problems and even death. There is also the risk of seriously damaging the device or parts of the operator's plant.



WARNING!

Disregarding this safety warning, even if only in part, poses the risk of serious health problems. There is also the risk of damaging the device or parts of the operator's plant.



CAUTION!

Disregarding these instructions can result in damage to the device or to parts of the operator's plant.



INFORMATION!

These instructions contain important information for the handling of the device.



LEGAL NOTICE!

This note contains information on statutory directives and standards.



• **HANDLING**

This symbol designates all instructions for actions to be carried out by the operator in the specified sequence.

➔ **RESULT**

This symbol refers to all important consequences of the previous actions.

1.4 Safety instructions for the operator



WARNING!

*In general, devices from the manufacturer may only be installed, commissioned, operated and maintained by properly trained and authorized personnel.
This document is provided to help you establish operating conditions, which will permit safe and efficient use of this device.*

2.1 Scope of delivery

**INFORMATION!**

Inspect the packaging carefully for damages or signs of rough handling. Report damage to the carrier and to the local office of the manufacturer.

**INFORMATION!**

Do a check of the packing list to make sure that you have all the elements given in the order.

**INFORMATION!**

Look at the device nameplate to ensure that the device is delivered according to your order.



Figure 2-1: Scope of delivery

- ① Ordered assembly
- ② Documentation

**INFORMATION!**

For further information contact your local sales office.

2.2 Device description

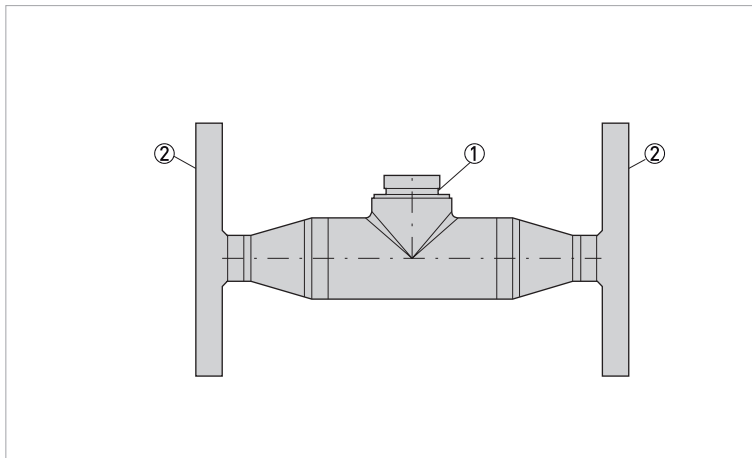

Figure 2-2: Construction of the assembly

- ① Sensor / assembly connection
- ② Process connection

The flow-through assembly is integrated into the process pipe and allows housing the assembly in which the sensor is built in. Both, process connection and sensor / assembly connection are available in different connection types. The flow-through assembly might either have a 180° or 90° angle of flow.

2.3 Nameplate

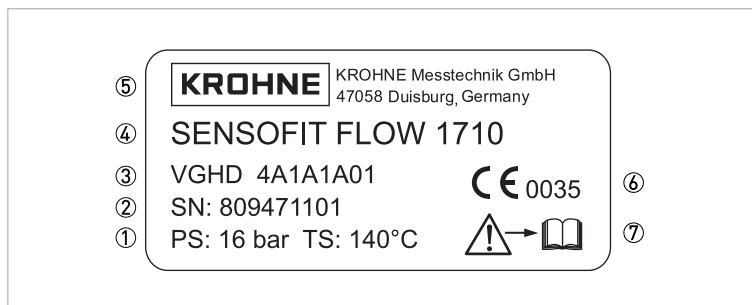

Figure 2-3: Example of a nameplate

- ① Max. static pressure and max. temperature
- ② Serial number
- ③ Order code
- ④ Device name
- ⑤ Manufacturer
- ⑥ CE marking
- ⑦ Observe the operation and installation instruction



INFORMATION!

Look at the device nameplate to ensure that the device is delivered according to your order.

3.1 General notes on installation

**INFORMATION!**

Inspect the packaging carefully for damages or signs of rough handling. Report damage to the carrier and to the local office of the manufacturer.

**INFORMATION!**

Do a check of the packing list to make sure that you have all the elements given in the order.

**INFORMATION!**

Look at the device nameplate to ensure that the device is delivered according to your order. Check for the correct supply voltage printed on the nameplate.

3.2 Storage and transport

- Store the assembly in its original packaging.
- Store and transport the device in a dry, dust-free environment.
- Store and transport the device in an environment with a temperature between -20...+80°C / -4...+176°F.
- The original packing is designed to protect the equipment. It has to be used if the device is transported or sent back to the manufacturer.

3.3 Pre-installation requirements

**CAUTION!**

Choosing the right gasket for the process connection as well as for the sensor-/assembly connection depends on the process conditions; the manufacturer can thus only give the general recommendation that the gasket must comply with the individual requirements of the measuring point (e.g. pressure, temperature, chemically aggressive media).

Ensure for the measuring point that

- the process is switched off.
- there is sufficient working space available for mounting of the assembly.
- pipelines are de-pressurised, empty and clean.
- the assembly connection and the process connection fit together.
- a process gasket is inserted between the flanges or the nominal widths of the pipes fit together at the weld ends.

Ensure for the assembly that

- the counterpart of the sensor/assembly connection is available and fits to the flow-through assembly.

3.4 Installing the assembly

Make sure that

1. the system is prepared.
2. the assembly is prepared.

For more information refer to *Pre-installation requirements* on page 10.

Steps to install the assembly

1. Insert the flow-through assembly into the prepared installation position and insert a appropriate gasket.
2. Connect the process connection and tighten. In case of weld ends, weld the flow-through assembly in.

Steps to install the sensor/assembly

1. Position the sensor/assembly to the prepared sensor/assembly connection and insert a appropriate gasket.
2. Tighten the connection.

Check the correct installation

1. Check if all connections are tight.
2. Check if no fluid escapes the process if the process starts again.

4.1 Maintenance

4.1.1 Availability of services

The manufacturer offers a range of services to support the customer after expiration of the warranty. These include repair, maintenance, technical support and training.



INFORMATION!

For more precise information, please contact your local sales office.

4.1.2 Spare parts availability

The manufacturer adheres to the basic principle that functionally adequate spare parts for each device or each important accessory part will be kept available for a period of 3 years after delivery of the last production run for the device.

This regulation only applies to spare parts which are subject to wear and tear under normal operating conditions.

4.1.3 Service instructions



CAUTION!

Installation, assembly, start-up and maintenance may only be performed by appropriately trained personnel. The regional occupational health and safety directives must always be observed.

Make up a special maintenance plan, depending on the process conditions. Check on a regular basis whether process fluid escapes.

4.2 Returning the device to the manufacturer

4.2.1 General information

This device has been carefully manufactured and tested. If installed and operated in accordance with these operating instructions, it will rarely present any problems.



CAUTION!

Should you nevertheless need to return a device for inspection or repair, please pay strict attention to the following points:

- *Due to statutory regulations on environmental protection and safeguarding the health and safety of the personnel, the manufacturer may only handle, test and repair returned devices that have been in contact with products without risk to personnel and environment.*
- *This means that the manufacturer can only service this device if it is accompanied by the following certificate (see next section) confirming that the device is safe to handle.*



CAUTION!

If the device has been operated with toxic, caustic, flammable or water-endangering products, you are kindly requested:

- *to check and ensure, if necessary by rinsing or neutralising, that all cavities are free from such dangerous substances,*
- *to enclose a certificate with the device confirming that is safe to handle and stating the product used.*

4.2.2 Form (for copying) to accompany a returned device



CAUTION!

To avoid any risk for our service personnel, this form has to be accessible from outside of the packaging with the returned device.

Company:		Address:	
Department:		Name:	
Tel. no.:		Fax no. and/or Email address:	
Manufacturer's order no. or serial no.:			
The device has been operated with the following medium:			
This medium is:	<input type="checkbox"/>	radioactive	
	<input type="checkbox"/>	water-hazardous	
	<input type="checkbox"/>	toxic	
	<input type="checkbox"/>	caustic	
	<input type="checkbox"/>	flammable	
	<input type="checkbox"/>	We checked that all cavities in the device are free from such substances.	
<input type="checkbox"/>	We have flushed out and neutralized all cavities in the device.		
We hereby confirm that there is no risk to persons or the environment through any residual media contained in the device when it is returned.			
Date:		Signature:	
Stamp:			

4.3 Disposal



CAUTION!

Disposal must be carried out in accordance with legislation applicable in your country.

Separate collection of WEEE (Waste Electrical and Electronic Equipment) in the European Union:



According to the directive 2012/19/EU, the monitoring and control instruments marked with the WEEE symbol and reaching their end-of-life **must not be disposed of with other waste**.

The user must dispose of the WEEE to a designated collection point for the recycling of WEEE or send them back to our local organisation or authorised representative.

5.1 Technical data

Design

Flow direction	180°
	90°
Process connections	Flange DN25
	Flange DN50
	Flange ANSI 1"
	Flange ANSI 2"
	Welding pipe DN25 / 1"
	Welding pipe DN50 / 2"
Sensor/Assembly connection	Flange DN50
	Flange ANSI 2"
	G1 1/4" (male)
	3/4-14 NPT (female)
	G3/4" (female)

Installation conditions

Operating conditions	Temperature range	-10...+140°C / 14...+284°F
	Process pressure	Max. 16 bar
Ambient conditions	Ambient temperature	-20...+95°C / -4...+203°F
	Transport and storage temperature	-20...+80°C / -4...+176°F

Materials

Assembly	1.4571, 316Ti
----------	---------------

5.2 Dimensions

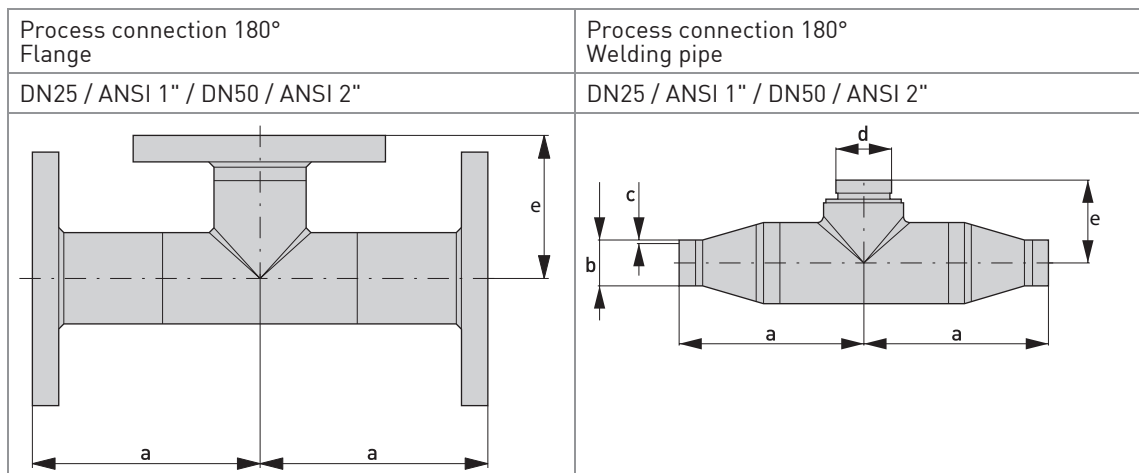

Table 5-1: Dimensions - Process connection 180° Flange and welding pipe

[mm]	DN25 / ANSI 1" / DN50 / ANSI 2"	DN25 / ANSI 1"	DN50 / ANSI 2"
a	150	140	137
b	-	33.7	60.3
c	-	2	2
d	-	G1 1/4	G1 1/4
e	93	62	62

[inch]	DN25 / ANSI 1" / DN50 / ANSI 2"	DN25 / ANSI 1"	DN50 / ANSI 2"
a	5.9	5.5	5.4
b	-	1.3	2.4
c	-	0.08	0.08
d	-	G1 1/4	G1 1/4
e	3.7	2.4	2.4

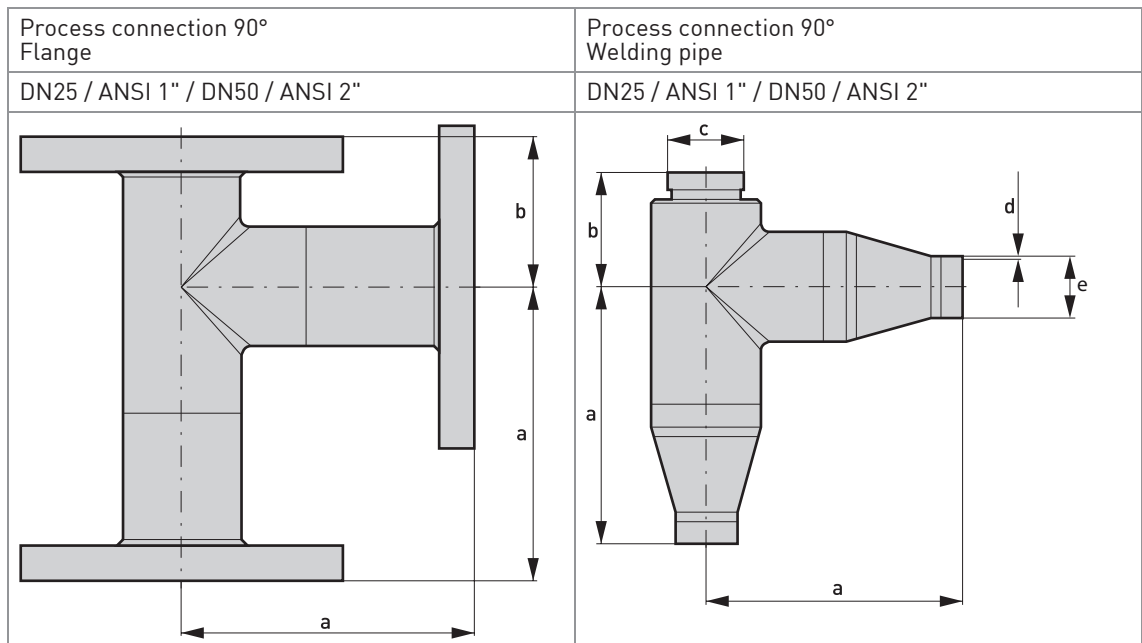

Table 5-2: Dimensions - Process connection 90° Flange and welding pipe

[mm]	DN25 / ANSI 1" / DN50 / ANSI 2"	DN25 / ANSI 1"	DN50 / ANSI 2"
a	150	140	137
b	77	62	62
c	-	G1 1/4	G1 1/4
d	-	2	2
e	-	33.7	60.3

[inch]	DN25 / ANSI 1" / DN50 / ANSI 2"	DN25 / ANSI 1"	DN50 / ANSI 2"
a	5.9	5.5	5.4
b	3	2.4	2.4
c	-	G1 1/4	G1 1/4
d	-	0.08	0.08
e	-	1.33	2.4







KROHNE – Process instrumentation and measurement solutions

- Flow
- Level
- Temperature
- Pressure
- Process Analysis
- Services

Head Office KROHNE Messtechnik GmbH
Ludwig-Krohne-Str. 5
47058 Duisburg (Germany)
Tel.: +49 203 301 0
Fax: +49 203 301 10389
info@krohne.com

The current list of all KROHNE contacts and addresses can be found at:
www.krohne.com

KROHNE