



TIDALFLUX 4300 F Handbook

Electromagnetic flow sensor for partially filled pipes

The documentation is only complete when used in combination with the relevant documentation for the converter.

All rights reserved. It is prohibited to reproduce this documentation, or any part thereof, without the prior written authorisation of KROHNE Messtechnik GmbH.

Subject to change without notice.

Copyright 2010 by
KROHNE Messtechnik GmbH - Ludwig-Krohne-Str. 5 - 47058 Duisburg (Germany)

1	Safety instructions	5
<hr/>		
1.1	Intended use	5
1.2	Safety instructions from the manufacturer	5
1.2.1	Copyright and data protection	5
1.2.2	Disclaimer	5
1.2.3	Product liability and warranty	6
1.2.4	Information concerning the documentation	6
1.2.5	Warnings and symbols used	7
1.3	Safety instructions for the operator	7
2	Device description	8
<hr/>		
2.1	Scope of delivery	8
2.2	Device description	8
2.3	Nameplates	8
3	Installation	9
<hr/>		
3.1	Notes on installation	9
3.2	Storage	9
3.3	Transport	9
3.4	Installation conditions	10
3.4.1	Inlet and outlet	10
3.4.2	Mounting position	10
3.4.3	Flange deviation	11
3.4.4	Vibration	11
3.4.5	Magnetic field	11
3.4.6	Control valve	12
3.4.7	Slope	12
3.4.8	Mounting advice for difficult situations	12
3.4.9	Cleaning of flow sensor	13
3.4.10	Temperatures	13
3.5	Mounting	14
3.5.1	Mounting grounding rings	14
3.5.2	Torques and pressures	14
4	Electrical connections	16
<hr/>		
4.1	Safety instructions	16
4.2	Important notes on electrical connection	16
4.3	Connection of cables	17
4.4	Cable lengths	18
4.5	Signal cable A (type DS 300), construction	19
4.6	Prepare signal cable A, connect to measuring sensor	20
4.7	Signal cable B (type BTS 300), construction	21
4.8	Preparing signal cable B, connection to measuring sensor	21
4.9	Preparing field current cable C, connection to measuring sensor	23
4.10	Interface cable	25
4.11	Grounding	25

5 Start-up	26
<hr/>	
5.1 Switching on the power	26
6 Service	27
<hr/>	
6.1 Spare parts availability	27
6.2 Availability of services	27
6.3 Returning the device to the manufacturer.....	27
6.3.1 General information.....	27
6.3.2 Form (for copying) to accompany a returned device.....	28
6.4 Disposal	28
7 Technical data	29
<hr/>	
7.1 Measuring principle.....	29
7.2 Technical data.....	31
7.3 Sizing	35
7.4 Dimensions and weights	37
7.5 Vacuum load	38
7.6 Measuring accuracy	39

1.1 Intended use

The TIDALFLUX 4300 F has been designed for measuring the flow of conductive fluids, even in partially filled pipes. It can be combined with the IFC 300 electromagnetic flow converter.

1.2 Safety instructions from the manufacturer

1.2.1 Copyright and data protection

The contents of this document have been created with great care. Nevertheless, we provide no guarantee that the contents are correct, complete or up-to-date.

The contents and works in this document are subject to German copyright. Contributions from third parties are identified as such. Reproduction, processing, dissemination and any type of use beyond what is permitted under copyright requires written authorisation from the respective author and/or the manufacturer.

The manufacturer tries always to observe the copyrights of others, and to draw on works created in-house or works in the public domain.

The collection of personal data (such as names, street addresses or e-mail addresses) in the manufacturer's documents is always on a voluntary basis whenever possible. Whenever feasible, it is always possible to make use of the offerings and services without providing any personal data.

We draw your attention to the fact that data transmission over the Internet (e.g. when communicating by e-mail) may involve gaps in security. It is not possible to protect such data completely against access by third parties.

We hereby expressly prohibit the use of the contact data published as part of our duty to publish an imprint for the purpose of sending us any advertising or informational materials that we have not expressly requested.

1.2.2 Disclaimer

The manufacturer will not be liable for any damage of any kind by using its product, including, but not limited to direct, indirect, incidental, punitive and consequential damages.

This disclaimer does not apply in case the manufacturer has acted on purpose or with gross negligence. In the event any applicable law does not allow such limitations on implied warranties or the exclusion of limitation of certain damages, you may, if such law applies to you, not be subject to some or all of the above disclaimer, exclusions or limitations.

Any product purchased from the manufacturer is warranted in accordance with the relevant product documentation and our Terms and Conditions of Sale.

The manufacturer reserves the right to alter the content of its documents, including this disclaimer in any way, at any time, for any reason, without prior notification, and will not be liable in any way for possible consequences of such changes.

1.2.3 Product liability and warranty

The operator shall bear responsibility for the suitability of the device for the specific purpose. The manufacturer accepts no liability for the consequences of misuse by the operator. Improper installation and operation of the devices (systems) will cause the warranty to be void. The respective "Standard Terms and Conditions" which form the basis for the sales contract shall also apply.

1.2.4 Information concerning the documentation

To prevent any injury to the user or damage to the device it is essential that you read the information in this document and observe applicable national standards, safety requirements and accident prevention regulations.

If this document is not in your native language and if you have any problems understanding the text, we advise you to contact your local office for assistance. The manufacturer can not accept responsibility for any damage or injury caused by misunderstanding of the information in this document.

This document is provided to help you establish operating conditions, which will permit safe and efficient use of this device. Special considerations and precautions are also described in the document, which appear in the form of underneath icons.

1.2.5 Warnings and symbols used

Safety warnings are indicated by the following symbols.



DANGER!

This information refers to the immediate danger when working with electricity.



DANGER!

This warning refers to the immediate danger of burns caused by heat or hot surfaces.



DANGER!

This warning refers to the immediate danger when using this device in a hazardous atmosphere.



DANGER!

These warnings must be observed without fail. Even partial disregard of this warning can lead to serious health problems and even death. There is also the risk of seriously damaging the device or parts of the operator's plant.



WARNING!

Disregarding this safety warning, even if only in part, poses the risk of serious health problems. There is also the risk of damaging the device or parts of the operator's plant.



CAUTION!

Disregarding these instructions can result in damage to the device or to parts of the operator's plant.



INFORMATION!

These instructions contain important information for the handling of the device.



LEGAL NOTICE!

This note contains information on statutory directives and standards.



• **HANDLING**

This symbol designates all instructions for actions to be carried out by the operator in the specified sequence.

➔ **RESULT**

This symbol refers to all important consequences of the previous actions.

1.3 Safety instructions for the operator



WARNING!

*In general, devices from the manufacturer may only be installed, commissioned, operated and maintained by properly trained and authorized personnel.
This document is provided to help you establish operating conditions, which will permit safe and efficient use of this device.*

2.1 Scope of delivery

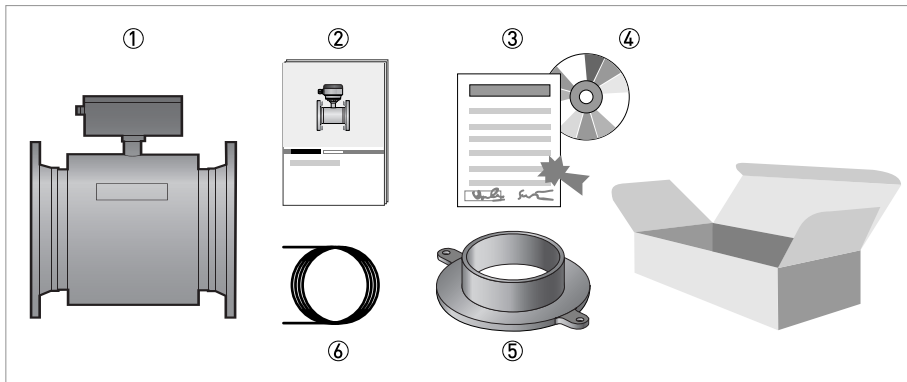

Figure 2-1: Scope of delivery

- ① Ordered flowmeter
- ② Product documentation
- ③ Factory calibration report
- ④ CD-ROM with product documentation
- ⑤ Grounding rings (optionally)
- ⑥ Cable

2.2 Device description

This flowmeter can measure the flow of conductive liquids, even in partially filled pipes. To be able to do this, a capacitive height measurement has been integrated into a normal electromagnetic flowmeter. If both the filled fraction and the velocity of the fluid are known, it is easy to calculate the amount of fluid running through the pipe.

2.3 Nameplates



INFORMATION!

Look at the device nameplate to ensure that the device is delivered according to your order. Check for the correct supply voltage printed on the nameplate.

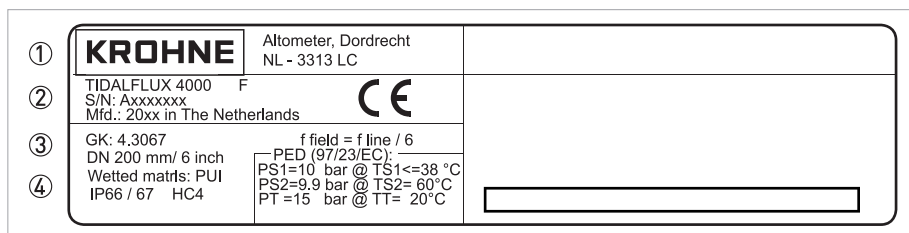

Figure 2-2: Example of nameplate

- ① Logo and address of manufacturer
- ② Type designation
- ③ GK/GKL values (measuring sensor constants); size (mm/inches); field frequency
- ④ Materials of wetted parts; protection category

3.1 Notes on installation

**INFORMATION!**

Inspect the cartons carefully for damage or signs of rough handling. Report damage to the carrier and to the local office of the manufacturer.

**INFORMATION!**

Check the packing list to check if you received completely all that you ordered.

**INFORMATION!**

Look at the device nameplate to ensure that the device is delivered according to your order. Check for the correct supply voltage printed on the nameplate.

3.2 Storage

- Store the device in a dry and dust-free location.
- Avoid lasting direct exposure to the sun.
- Store the device in its original packing.

3.3 Transport

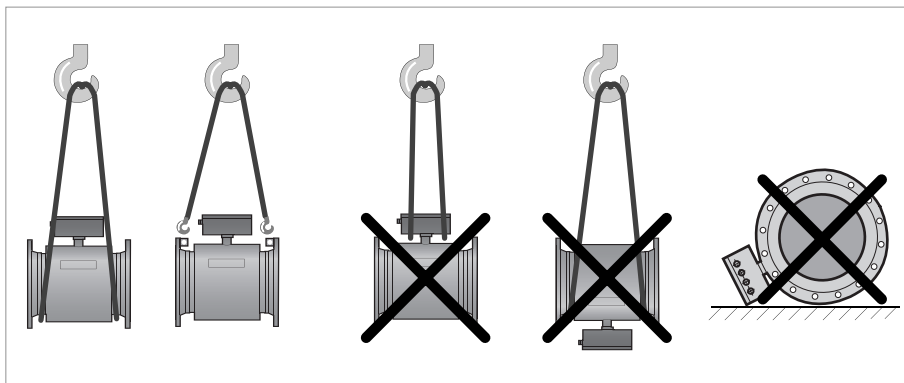

Figure 3-1: Transport

3.4 Installation conditions

3.4.1 Inlet and outlet

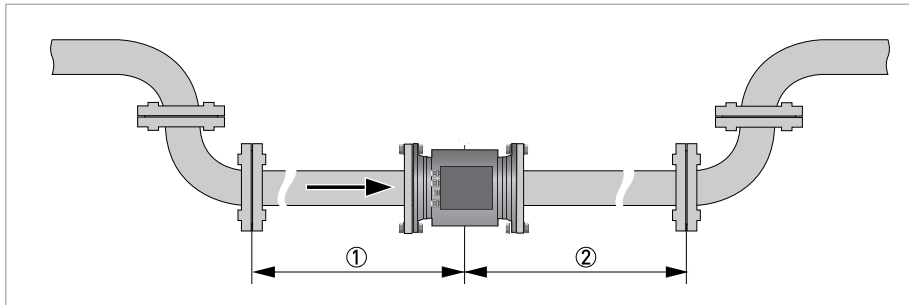

Figure 3-2: Recommended inlet and outlet sections, top view

- ① ≥ 5 DN
- ② ≥ 3 DN

3.4.2 Mounting position



CAUTION!

Only install the flow sensor in the shown position to keep the electrodes under water. Limit the rotation to $\pm 2^\circ$ to maintain the accuracy.

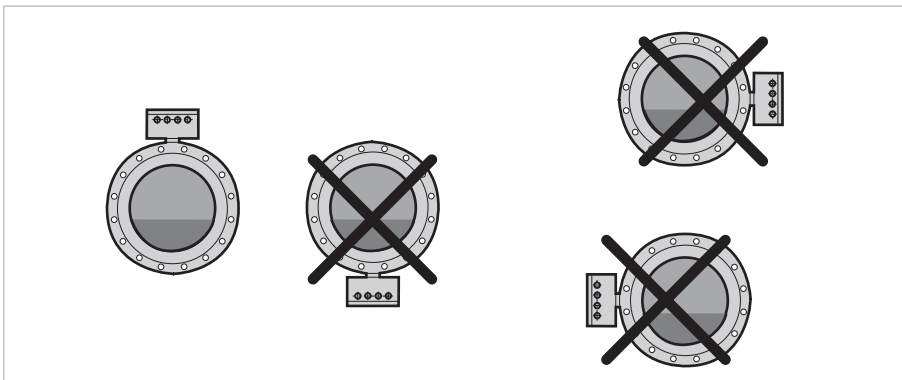

Figure 3-3: Mounting position

3.4.3 Flange deviation

**CAUTION!**

Max. permissible deviation of pipe flange faces:

$$L_{max} - L_{min} \leq 0.5 \text{ mm} / 0.02''$$

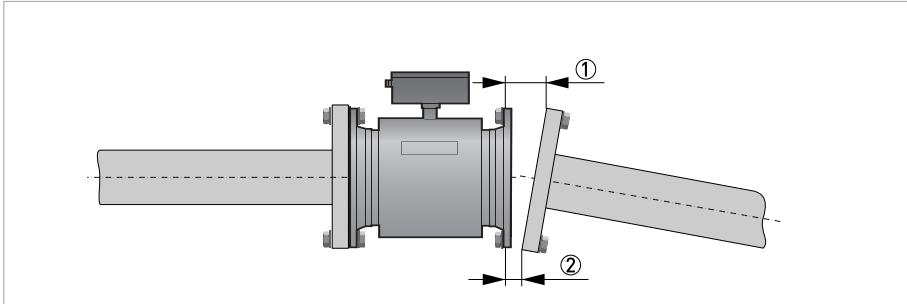

Figure 3-4: Flange deviation

- ① L_{max}
- ② L_{min}

3.4.4 Vibration

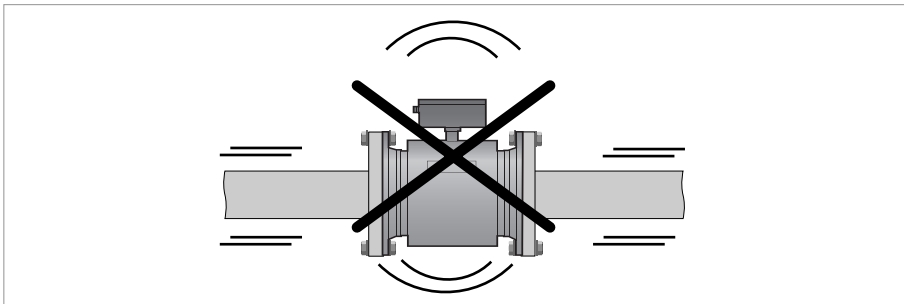

Figure 3-5: Avoid vibrations

3.4.5 Magnetic field

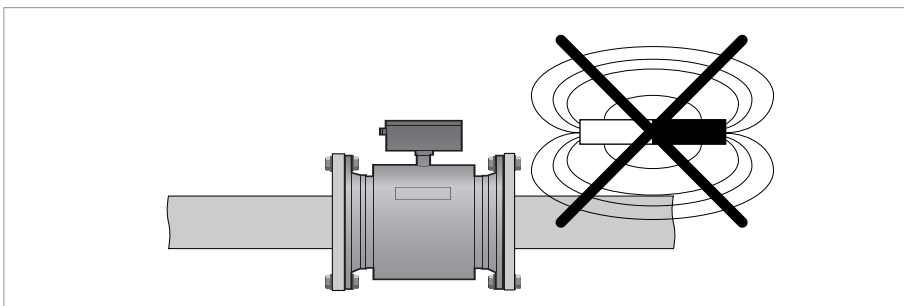

Figure 3-6: Avoid magnetic fields

3.4.6 Control valve

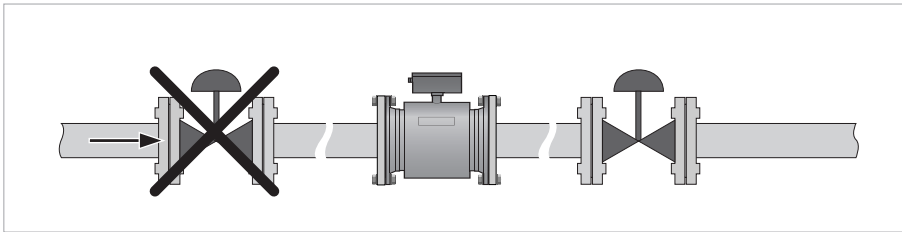

Figure 3-7: Installation before control valve

3.4.7 Slope



CAUTION!

The accuracy is influenced by the slope. Stay within $\pm 1\%$ to get the most accurate measurements!

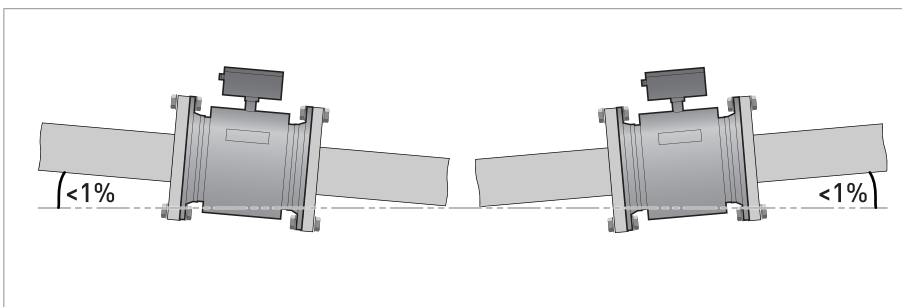

Figure 3-8: Recommended slope

3.4.8 Mounting advice for difficult situations

If you can not meet the installation conditions install the flowmeter between two containers. The inlet to the flowmeter must be higher than the outlet of the fluid. In this way you will have a calm flow into the flowmeter, resulting in a highly accurate measurement. The sizes of the containers must be proportional to the size of the flowmeter.

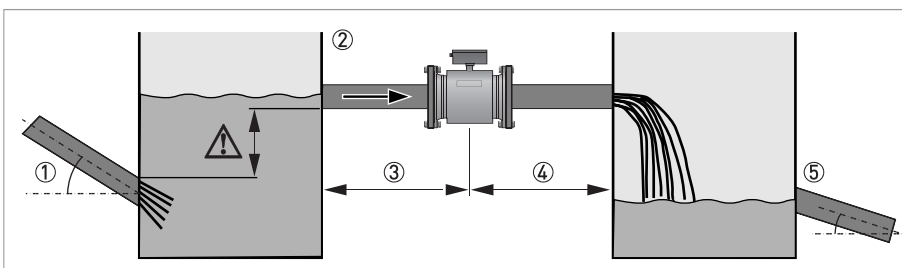

Figure 3-9: Installing in difficult situations

- ① Use a container ② if the Inlet pipe has a slope $> 1\%$. Make sure that the outlet level of this pipe is below the inlet to the flowmeter.
- ② Inlet container
- ③ Inlet section of 10 DN
- ④ Outlet section of 5 DN
- ⑤ Outlet container advisable if outlet pipe has a slope $> 1\%$.

3.4.9 Cleaning of flow sensor

The TIDALFLUX flow sensor is highly resistant against dirt and the measurement will rarely be influenced by anything. However, it is advisable to create a possibility for cleaning just before or after the sensor.

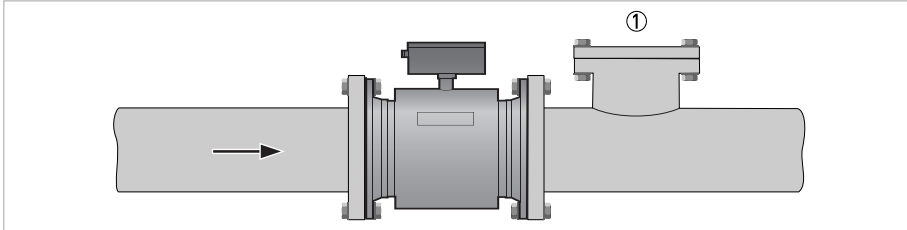

Figure 3-10: Option for cleaning of flow sensor

① Opening for cleaning

3.4.10 Temperatures

Temperature range	Process [°C]		Ambient [°C]		Process [°F]		Ambient [°F]	
	min.	max.	min.	max.	min.	max.	min.	max.
All versions	-5	60	-25	60	23	140	-13	140

3.5 Mounting

3.5.1 Mounting grounding rings



CAUTION!

In order to get a reliable height measurement it is **absolutely necessary** that the inner side of the connecting pipeline is electrically conductive and connected to ground. If not, tailor-made grounding rings with a cylindrical part can be delivered. Please contact your local agency in case of doubt.

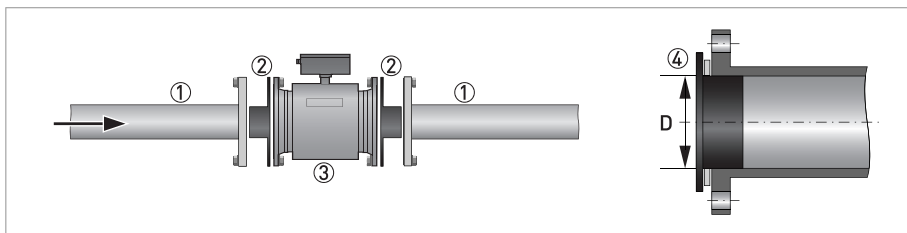

Figure 3-11: Grounding with grounding rings

- ① Existing pipeline
- ② Grounding rings, custom made to inner diameter of pipeline
- ③ TIDALFLUX
- ④ Insert the cylindrical part of the grounding ring into the pipeline. Use an appropriate gasket between the grounding ring and the flange.



INFORMATION!

Sizes of the grounding rings are diameter dependent and available on request.

3.5.2 Torques and pressures

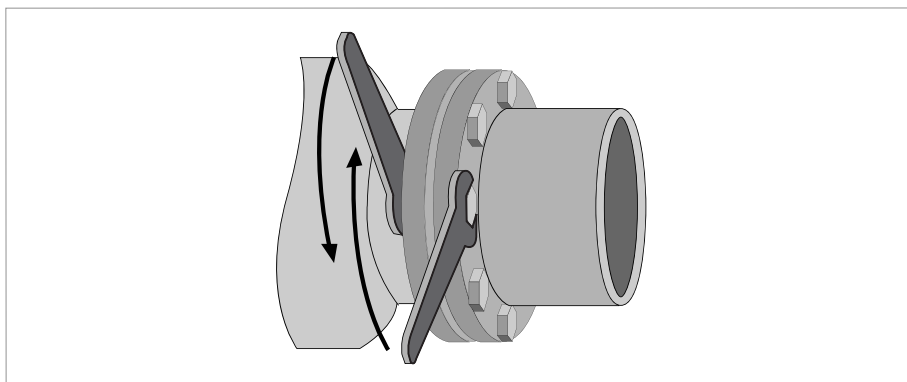

Figure 3-12: Tightening of bolts



Tightening of bolts

- ① Step 1: Apply approx. 50% of max. torque given in table.
- ② Step 2: Apply approx. 80% of max. torque given in table.
- ③ Step 3: Apply 100% of max. torque given in table.

**INFORMATION!**

Tighten the bolts uniformly in diagonally opposite sequence.

Nominal size DN [mm]	Pressure rating	Bolts	Max. torque [Nm]
200	PN 10	8 × M 20	68
250	PN 10	12 × M 20	65
300	PN 10	12 × M 20	76
350	PN 10	16 × M 20	75
400	PN 10	16 × M 24	104
500	PN 10	20 × M 24	107
600	PN 10	20 × M 27	138
700	PN 10	20 × M 27	163
800	PN 10	24 × M 30	219
900	PN 10	28 × M 30	205
1000	PN 10	28 × M 35	261

Nominal size [inch]	Flange class [lb]	Bolts	Max. torque [Nm]
8	150	8 × 3/4"	69
10	150	12 × 7/8"	79
12	150	12 × 7/8"	104
14	150	12 × 1"	93
16	150	16 × 1"	91
18	150	16 × 1 1/8"	143
20	150	20 × 1 1/8"	127
24	150	20 × 1 1/4"	180
28	150	28 × 1 1/4"	161
32	150	28 × 1 1/2"	259
36	150	32 × 1 1/2"	269
40	150	36 × 1 1/2"	269

**INFORMATION!**

Information for bigger sizes is available on request.

4.1 Safety instructions

**DANGER!**

All work on the electrical connections may only be carried out with the power disconnected. Take note of the voltage data on the nameplate!

**DANGER!**

Observe the national regulations for electrical installations!

**WARNING!**

Observe without fail the local occupational health and safety regulations. Any work done on the electrical components of the measuring device may only be carried out by properly trained specialists.

**INFORMATION!**

Look at the device nameplate to ensure that the device is delivered according to your order. Check for the correct supply voltage printed on the nameplate.

4.2 Important notes on electrical connection

**DANGER!**

Electrical connection is carried out in conformity with the VDE 0100 directive "Regulations for electrical power installations with line voltages up to 1000 V" or equivalent national regulations.

**CAUTION!**

- Use suitable cable entries for the various electrical cables.
- The sensor and converter are configured together in the factory. For this reason, please connect the devices in pairs. Ensure that the sensor constant GK (see type plates) are identically set

4.3 Connection of cables

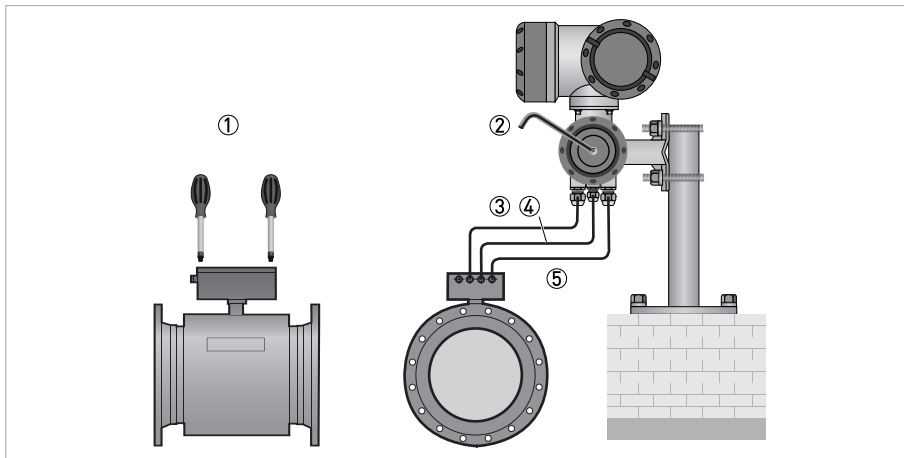

Figure 4-1: Electrical connection

- ① Unscrew the cover to reach the connectors
- ② Unscrew the cover to reach the connectors
- ③ Field current cable
- ④ Interface cable
- ⑤ Signal cable (DS or BTS)

Connection diagram

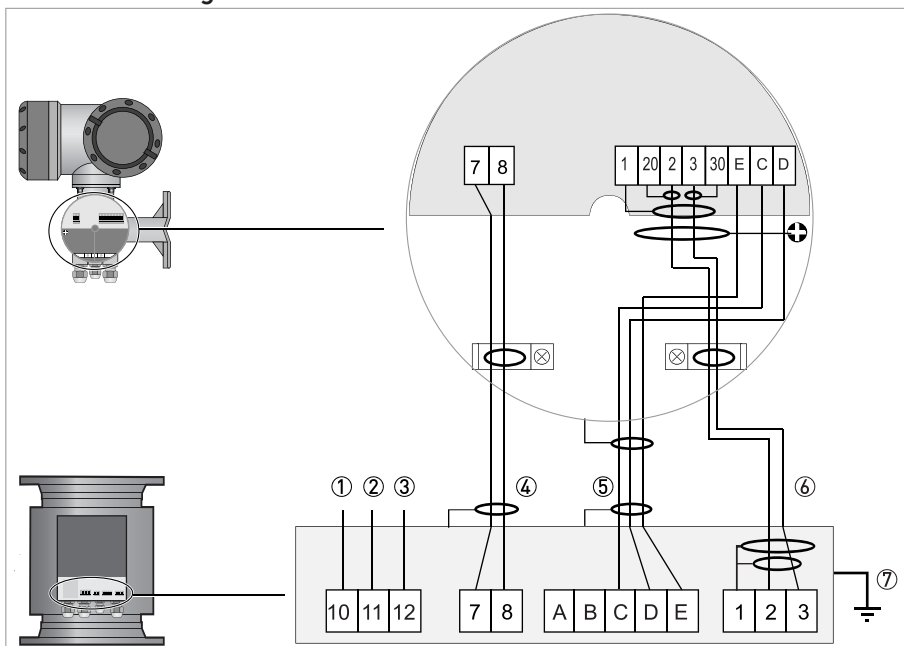

Figure 4-2: Connection diagram

- ① Protective Earth connection (PE)
- ② Mains power neutral (N)
- ③ Mains power live (L)
- ④ Field current cable
- ⑤ Interface cable
- ⑥ Signal cable. Shown is the BTS cable. In case of DS cable, do not use connectors 20 and 30.
- ⑦ Connect housing to PE

Flow sensors with protection class IP 68 can not be opened anymore. The cables are factory connected and labeled as follows.

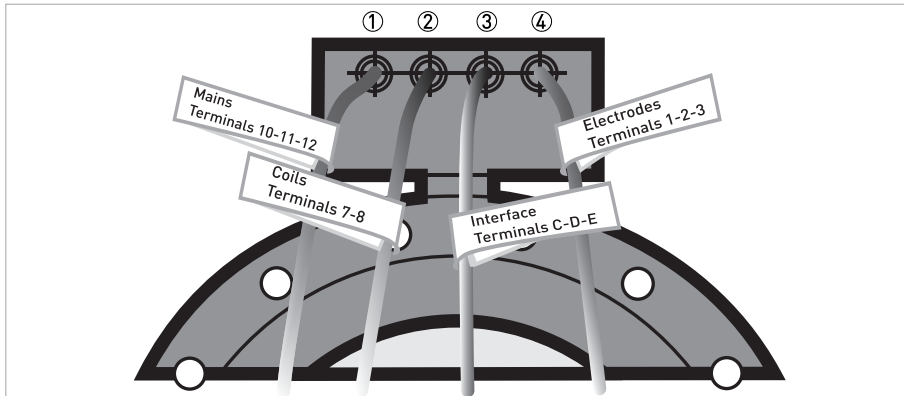

Figure 4-3: Labeled cables for IP 68 versions

- ① Mains power (10 = blank, 11 = blue, 12 = black)
- ② Field current (7 = white, 8 = green)
- ③ Data interface (black wires, C = marked "1", D = marked "2", E = marked "3")
- ④ Electrodes (1 = blank, 2 = white, 3 = red)

4.4 Cable lengths



CAUTION!

The maximum allowed distance between the flow sensor and the converter is determined by the shortest cable length.

Interface cable: maximum length is 600 m.

Type B (BTS) signal cable: maximum length is 600 m.

Type A (DS) signal cable: the maximum length depends on the conductivity of the fluid:

Electrical conductivity [µS/cm]	Maximum length [m]
50	120
100	200
200	400
≥400	600

Field current cable: The cross section of the cable determines the maximum length:

Cross section	Maximum length [m]
2 x 0.75 mm ²	150
2 x 1.5 mm ²	300
2 x 2.5 mm ²	600

4.5 Signal cable A (type DS 300), construction

- Signal cable A is a double-shielded cable for signal transmission between the measuring sensor and signal converter.
- Bending radius: $\geq 50 \text{ mm} / 2''$

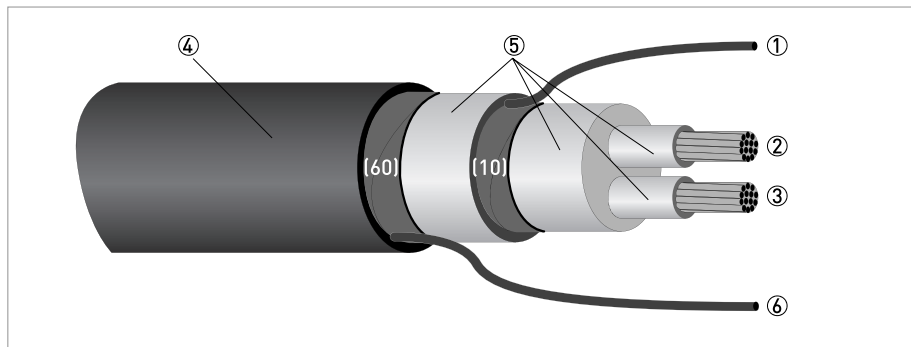

Figure 4-4: Construction of signal cable A

- ① Stranded drain wire (1) for the inner shield (10), $1.0 \text{ mm}^2 \text{ Cu}$ / AWG 17 (not insulated, bare)
- ② Insulated wire (2), $0.5 \text{ mm}^2 \text{ Cu}$ / AWG 20
- ③ Insulated wire (3), $0.5 \text{ mm}^2 \text{ Cu}$ / AWG 20
- ④ Outer sheath
- ⑤ Insulation layers
- ⑥ Stranded drain wire (6) for the outer shield (60)

4.6 Prepare signal cable A, connect to measuring sensor



INFORMATION!

Assembly materials and tools are not part of the delivery. Use the assembly materials and tools in compliance with the applicable occupational health and safety directives.

Required materials

- PVC insulation tubing, $\varnothing 2.0 \dots 2.5$ mm / 0.08...0.1"
- Heat-shrinkable tubing
- Wire end ferrule to DIN 46 228: E 1.5-8 for the twisted stranded drain wires (1) and (6)
- 2x wire end ferrules to DIN 46 228: E 0.5-8 for the insulated conductors (2, 3)

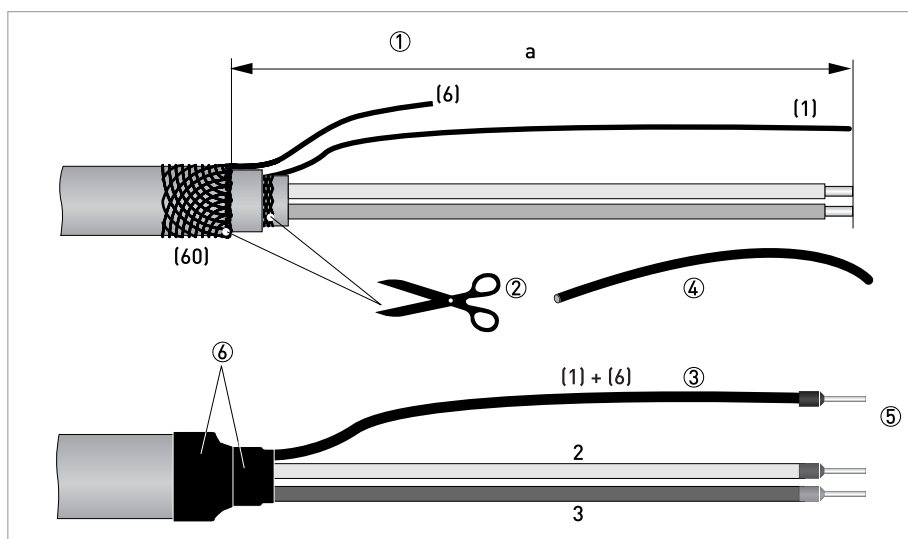

Figure 4-5: Prepare signal cable A, connect to measuring sensor

a = 50 mm / 2"



- ① Strip the conductor to dimension a.
- ② Cut the outer shields (60) and (10). Make sure not to damage the stranded drain wires (1) and (6).
- ③ Twist the stranded drain wires (6) of the outer shield and the drain wire (1) of the inner shield (10).
- ④ Slide an insulating tube over the stranded drain wires (1) and (6).
- ⑤ Crimp the wire end ferrules onto conductors 2 and 3 and the stranded drain wires (1) and (6).
- ⑥ Pull the heat-shrinkable tubing over the prepared signal cable.

4.7 Signal cable B (type BTS 300), construction

- Signal cable B is a triple-shielded cable for signal transmission between the measuring sensor and signal converter.
- Bending radius: $\geq 50 \text{ mm} / 2''$

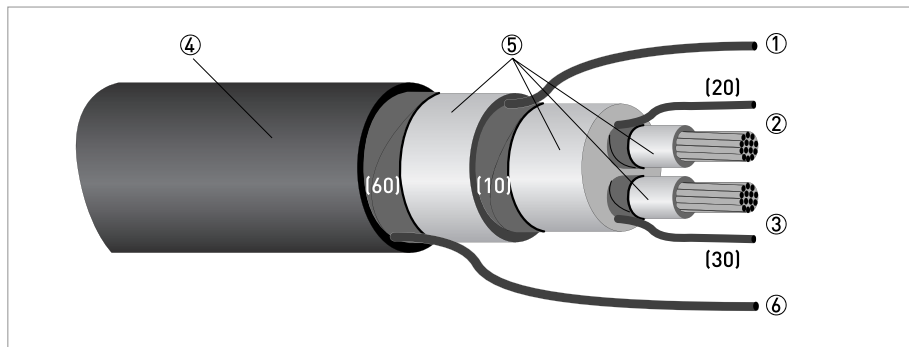

Figure 4-6: Construction of signal cable B

- ① Stranded drain wire for the inner shield (10), 1.0 mm² Cu / AWG 17 (not insulated, bare)
- ② Insulated wire (2), 0.5 mm² Cu / AWG 20 with stranded drain wire (20) of shield
- ③ Insulated wire (3), 0.5 mm² Cu / AWG 20 with stranded drain wire (30) of shield
- ④ Outer sheath
- ⑤ Insulation layers
- ⑥ Stranded drain wire (6) for the outer shield (60), 0.5 mm² Cu / AWG 20 (not insulated, bare)

4.8 Preparing signal cable B, connection to measuring sensor



INFORMATION!

Assembly materials and tools are not part of the delivery. Use the assembly materials and tools in compliance with the applicable occupational health and safety directives.

Required materials

- PVC insulation tubing, $\varnothing 2.0 \dots 2.5 \text{ mm} / 0.08 \dots 0.1''$
- Heat-shrinkable tubing
- Wire end ferrule to DIN 46 228: E 1.5-8 for the twisted stranded drain wires (1) and (6)
- 2x wire end ferrules to DIN 46 228: E 0.5-8 for the insulated conductors (2, 3)

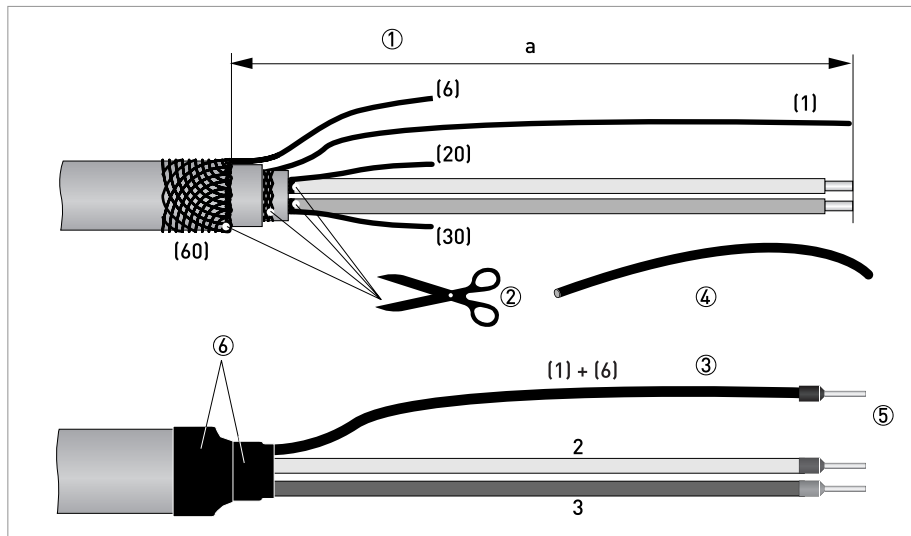

Figure 4-7: Preparing signal cable B, connection to measuring sensor

a = 50 mm / 2"



- ① Strip the conductor to dimension a.
- ② Cut the outer shields (60), (10), the shields around the insulated conductors (2, 3) and the stranded drain wires (20, 30). Make sure not to damage the stranded drain wires (1) and (6).
- ③ Twist the stranded drain wires (6) of the outer shield and the drain wire (1) of the inner shield (10).
- ④ Slide an insulating tube over the stranded drain wires (1) and (6).
- ⑤ Crimp the wire end ferrules onto conductors 2 and 3 and the stranded drain wires (1) and (6).
- ⑥ Pull the heat-shrinkable tubing over the prepared signal cable.

4.9 Preparing field current cable C, connection to measuring sensor



INFORMATION!

Assembly materials and tools are not part of the delivery. Use the assembly materials and tools in compliance with the applicable occupational health and safety directives.

- The field current cable is not part of the scope of supply.
- The shield is connected in the terminal compartment of the converter directly via the shield and a clip.
- The shield is connected in the sensor via the special cable gland.
- Bending radius: $\geq 50 \text{ mm} / 2''$

Required materials

- Shielded 2-wire insulated copper cable
- Insulating tubing, size according to the cable being used
- Heat-shrinkable tubing
- DIN 46 228 wire end ferrules: size according to the cable being used

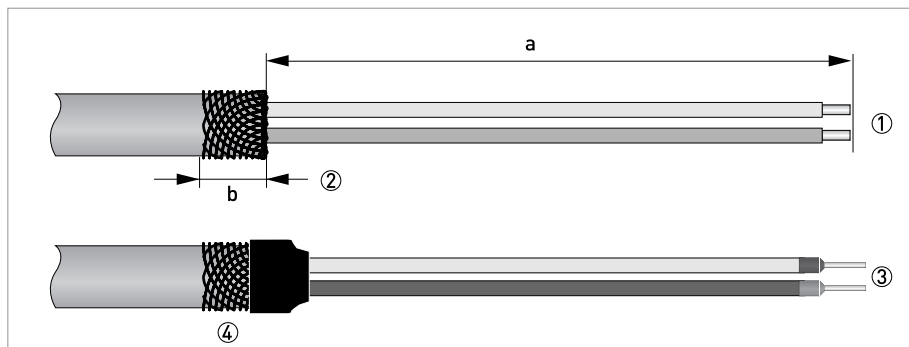

Figure 4-8: Preparation of field current cable C

a = 50 mm / 2"

b = 10 mm / 0.4"



- ① Strip the conductor to dimension a.
- ② Trim the outer shield to dimension b and pull it over the outer sheath.
- ③ Crimp wire end ferrules onto both conductors.
- ④ Pull a shrinkable tube over the prepared cable.

At flow converter side:

Connecting shielding under clamp in connection box of converter

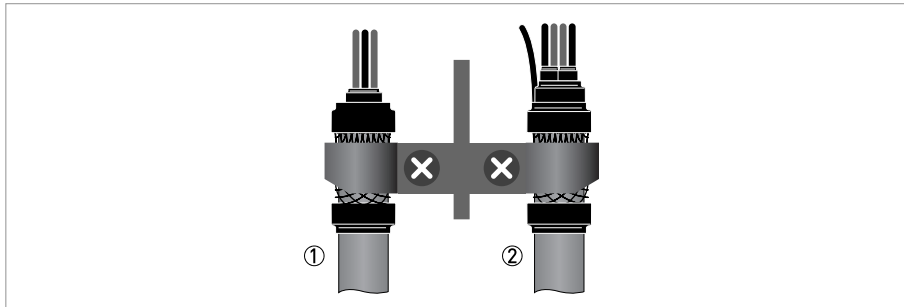

Figure 4-9: Clamping of shields

- ① Field current cable
- ② Signal cable

At flow sensor side:

Connecting shielding via special cable gland

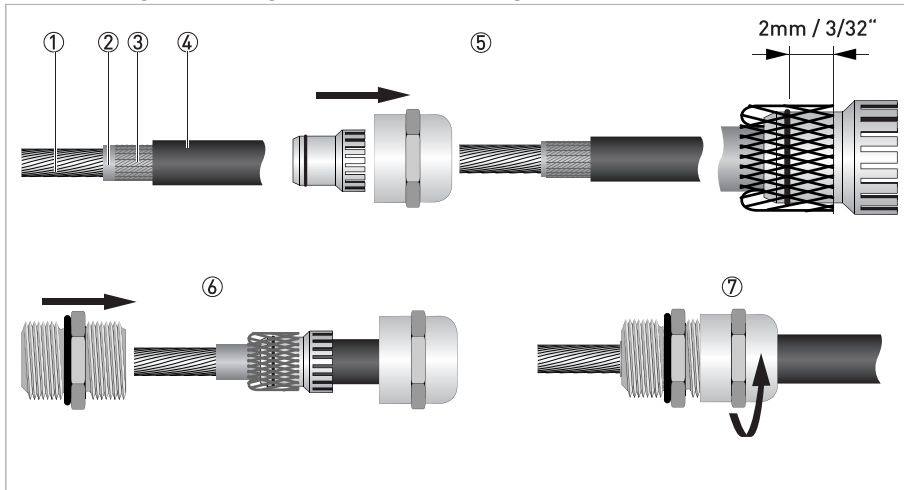

Figure 4-10: Connecting the shield within the cable gland

- ① Wires
- ② Isolation
- ③ Shielding
- ④ Isolation
- ⑤ Feed cable through dome nut and clamping insert and fold shielding over clamping insert. Make sure that the braided shield overlaps the O-ring by 2 mm / 3/32".
- ⑥ Push clamping insert into body.
- ⑦ Tighten the dome nut.

4.10 Interface cable

The data interface cable is a shielded, $3 \times 1.5 \text{ mm}^2$ Liycy cable. Standard is 10 m included in the delivery. Connect the shielding at both sides of the cable via the special cable gland.

Connecting shielding via special cable gland

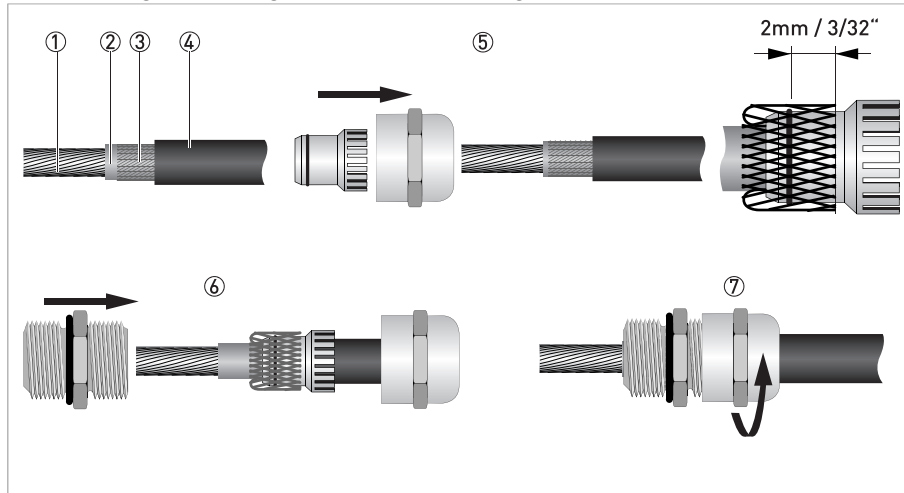

Figure 4-11: Connecting the shield within the cable gland

- ① Wires
- ② Isolation
- ③ Shielding
- ④ Isolation
- ⑤ Feed cable through dome nut and clamping insert and fold shielding over clamping insert. Make sure that the braided shield overlaps the O-ring by 2 mm / 3/32".
- ⑥ Push clamping insert into body.
- ⑦ Tighten the dome nut.

4.11 Grounding



DANGER!

The device must be grounded in accordance with regulations in order to protect personnel against electric shocks.



CAUTION!

*In order to get a reliable height measurement it is **absolutely necessary** that the inner side of the connecting pipeline is electrically conductive and connected to ground. If not, tailor-made grounding rings with a cylindrical part can be delivered. Please contact your local agency in case of doubt.*

5.1 Switching on the power

Before connecting to power, please check that the system has been correctly installed. This includes:

- The device must be mechanically mounted safely in compliance with the regulations.
- The power connections must be in compliance with the regulations.
- Make sure that all electrical connections are made and that the covers of the terminal compartments are closed.
- Check that the electrical operating data of the power supply are correct.



- Switch on the power.



INFORMATION!

The sensor can not be programmed or changed in any way. All settable functions are included in the converter. Please see the relevant documentation of the converter for more information.

6.1 Spare parts availability

The manufacturer adheres to the basic principle that functionally adequate spare parts for each device or each important accessory part will be kept available for a period of 3 years after delivery of the last production run for the device.

This regulation only applies to spare parts which are under normal operating conditions subjects to wear and tear.

6.2 Availability of services

The manufacturer offers a range of services to support the customer after expiration of the warranty. These include repair, technical support and training.



INFORMATION!

For more precise information, please contact your local representative.

6.3 Returning the device to the manufacturer

6.3.1 General information

This device has been carefully manufactured and tested. If installed and operated in accordance with these operating instructions, it will rarely present any problems.



CAUTION!

Should you nevertheless need to return a device for inspection or repair, please pay strict attention to the following points:

- *Due to statutory regulations on environmental protection and safeguarding the health and safety of our personnel, manufacturer may only handle, test and repair returned devices that have been in contact with products without risk to personnel and environment.*
- *This means that the manufacturer can only service this device if it is accompanied by the following certificate (see next section) confirming that the device is safe to handle.*



CAUTION!

If the device has been operated with toxic, caustic, flammable or water-endangering products, you are kindly requested:

- *to check and ensure, if necessary by rinsing or neutralizing, that all cavities are free from such dangerous substances,*
- *to enclose a certificate with the device confirming that is safe to handle and stating the product used.*

6.3.2 Form (for copying) to accompany a returned device

Company:		Address:	
Department:		Name:	
Tel. no.:		Fax no.:	
Manufacturer's order no. or serial no.:			
The device has been operated with the following medium:			
This medium is:	water-hazardous		
	toxic		
	caustic		
	flammable		
	We checked that all cavities in the device are free from such substances.		
	We have flushed out and neutralized all cavities in the device.		
We hereby confirm that there is no risk to persons or the environment through any residual media contained in the device when it is returned.			
Date:		Signature:	
Stamp:			

6.4 Disposal

**CAUTION!**

Disposal must be carried out in accordance with legislation applicable in your country.

7.1 Measuring principle

The TIDALFLUX 4000 is an electromagnetic flow sensor with an integrated capacitive level measurement system, designed for electrically conductive process liquids. The flow rate $Q(t)$ through the tube is:

$Q(t) = v(t) \times A(t)$, in which

$v(t)$ = Flow velocity of liquid product

$A(t)$ = Wetted area of tube section.

The flow velocity is determined on basis of the known electromagnetic measurement principle. The two measuring electrodes are located in the lower part of the measuring tube, on a level of approx. 10% of the inner diameter of the pipe in order to get a reliable measurement to a level of 10%.

An electrically conductive fluid flows inside an electrically insulating pipe through a magnetic field. This magnetic field is generated by a current, flowing through a pair of field coils. Inside of the fluid, a voltage U is generated:

$$U = v * k * B * D$$

in which:

v = mean flow velocity

k = factor correcting for geometry

B = magnetic field strength

D = inner diameter of flow meter

The signal voltage U is picked off by electrodes and is proportional to the mean flow velocity v and thus the flow rate q . The signal voltage is quite small (typically 1 mV at $v = 3 \text{ m/s} / 10 \text{ ft/s}$ and field coil power of 1 W). Finally, a signal converter is used to amplify the signal voltage, filter it (separate from noise) and convert it into signals for totalising, recording and output processing.

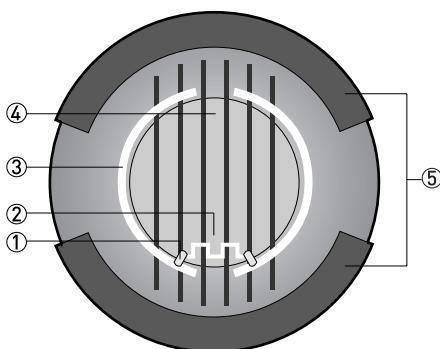

Figure 7-1: Measuring principle TIDALFLUX

- ① Electrodes
- ② Induced voltage [proportional to flow velocity]
- ③ Capacitive plates in liner for height measurement
- ④ Magnetic field
- ⑤ Field coils

The wetted area A is computed from the known inside diameter of the pipe by the patented capacitive level measurement system that is built into the measuring tube liner. The required electronics unit is accommodated in a compact housing that is mounted on top of the measuring sensor. This electronics is connected to the remote IFC 300 F converter by means of a digital communication line.

7.2 Technical data



INFORMATION!

- *The following data is provided for general applications. If you require data that is more relevant to your specific application, please contact us or your local representative.*
- *Additional information (certificates, special tools, software,...) and complete product documentation can be downloaded free of charge from the website (Download Center).*

Measuring system

Measuring principle	Faraday's law
Application range	Electrically conductive fluids
Measured value	
Primary measured value	Flow velocity
	Level
Secondary measured value	Volume flow

Design

Features	Flange version with full bore flow tube
	Standard as well as higher pressure ratings
	Broad range of nominal sizes
Modular construction	The measurement system consists of a flow sensor and a signal converter. It is available as remote version. More information about the signal converter can be found in the documentation of the signal converter.
Remote version	In field (F) version with IFC 300 converter: TIDALFLUX 4300 F.
Nominal diameter	DN200...1600 / 8...64"
Measurement range	-12...+12 m/s / -40...+40 ft/s

Measuring accuracy

Reference conditions	Slope: 0%
	Medium: water
	Electrical conductivity: 50...5000 $\mu\text{S}/\text{cm}$
	Temperature: 10...30°C / 50...86°F
	Inlet section: ≥ 10 DN
	Outlet section: ≥ 5 DN
	Flow velocity at full scale: > 1 m/s / 3 ft/s
	Operating pressure: 1 bar / 14.5 psig
	Wet calibrated on EN 17025 accredited calibration rig by direct volume comparison
Maximum measuring error	For detailed information on the measuring accuracy, see chapter "Measuring accuracy".
	Related to volume flow (MV = Measured Value, FS = Full Scale)
	These values are related to the pulse / frequency output
	The additional typical measuring deviation for the current output is ± 10 μA
	Partly filled:
	$v \geq 1$ m/s / 3.3 ft/s @ Full Scale: $\leq 1\%$ of FS
	Fully filled:
	$v \geq 1$ m/s / 3.3 ft/s: $\leq 1\%$ of MV
	$v < 1$ m/s / 3.3 ft/s: $\leq 0.5\%$ of MV + 5 mm/s / 0.2 inch/s
Minimum level: 10% of inner diameter	

Operating conditions

Temperature	
Process temperature	-5...+60°C / 23...+140°F
Ambient temperature	-40...+65°C / -40...+149°F (Protect electronics against self-heating with ambient temperatures above 55°C)
Storage temperature	-50...+70°C / -58...+158°F
Chemical properties	
Physical condition	Conductive liquids
Electrical conductivity	≥ 50 $\mu\text{S}/\text{cm}$
Permissible gas content (volume)	$\leq 5\%$
Permissible solid content (volume)	$\leq 70\%$

Installation conditions

Installation	For detailed information see chapter "Installation"
Flow direction	Forward and reverse. Arrow on flow sensor indicates positive flow direction.
Inlet run	≥ 5 DN (without disturbing flow, after a single 90° bend) ≥ 10 DN (after a double bend 2x 90°) ≥ 10 DN (behind a control valve)
Outlet run	≥ 3 DN
Dimensions and weights	For detailed information see chapter "Dimensions and weights".

Materials

Sensor housing	Standard: sheet steel
	Other materials on request
Measuring tube	Austenitic stainless steel
Flange	Standard: Carbon steel, polyurethane coated
	Other materials on request
Liner	Polyurethane
Connection box	IP 67: polyurethane coated die-cast aluminium
	IP 68: Stainless steel
Measuring electrodes	Hastelloy® C
Grounding rings	Stainless steel
	Tailor made to innerdiameter of connecting pipeline.
	Necessary if innerside of connecting pipeline isn't electrically conductive.

Process connections

Flange	
EN 1092-1	DN200...1600 in PN 6...40 (others on request)
ASME	8...64" in 150...300 lb RF (others on request)
JIS	DN200...1600 in JIS 10...20 K (others on request)
Design of gasket surface	RF (others on request)

Electrical connections

General	Electrical connection is carried out in conformity with the VDE 0100 directive "Regulations for electrical power installations with line voltages up to 1000 V" or equivalent national specifications.
Power supply	Standard: 110 / 220 VAC (-15% / +10%), 50/60 Hz settable by switch
	Option: 24 VAC, 50/60 Hz
Power consumption	14 VA
Field current cable	Shielded cable must be used, no part of delivery.
Signal cable	DS 300 (type A) Max. length: 600 m / 1950 ft (dependent on electrical conductivity).
	BTS 300 (type B) Max. length: 600 m / 1950 ft
Data interface cable	For transmission of measured level to IFC 300 F.
	Shielded Liycy cable, 3 x 0.75 mm ²
Cable entries	2x M20 x 1.5
	1x M20 x 1.5 EMC type
	1x PG9 EMC type

Approvals and certificates

CE	
	This device fulfills the statutory requirements of the EC directives. The manufacturer certifies successful testing of the product by applying the CE mark.
Electromagnetic compatibility	Directive: 2004/108/EC, NAMUR NE21/04
	Harmonized standard: EN 61326-1 : 2006
Low voltage directive	Directive: 2006/95/EC
	Harmonized standard: EN 61010 : 2001
Pressure equipment directive	Directive: 97/23/EC
	Category I, II or SEP
	Fluid group 1
	Production module H
Hazardous areas	
ATEX	Option: Ex zone 2
	Ex zone 1 in preparation
Other approvals and standards	
Protection category acc. to IEC 529 / EN 60529	Standard: IP 66/67 (NEMA 4/4X/6)
	Option: IP 68 (NEMA 6P)
Vibration resistance	IEC 68-2-6
Random vibration test	IEC 68-2-34
Shock test	IEC 68-2-27

7.3 Sizing



INFORMATION!

These tables state the flowrate in a partially filled pipe, dependant on slope, filling level, inner diameter and friction factors of the pipe. The values are calculated according the Manning-Strickler equation. The results do not consider: deposits, profile distortion, backwater, friction of air and the slightly smaller inner diameter of the TIDALFLUX.

Flow and velocity at 100% level, gravity fed, metric values

DN	Steel / PVC		Smooth concrete		Concrete	
	v [m/s]	Q [m3/h]	v [m/s]	Q [m3/h]	v [m/s]	Q [m3/h]

slope 0.5%

200	0.96	109	0.86	97	0.58	66
250	1.11	196	1.00	177	0.67	118
300	1.26	321	1.13	288	0.75	191
350	1.39	481	1.25	433	0.84	291
400	1.52	688	1.37	620	0.91	412
500	1.77	1251	1.59	1124	1.06	749
600	2.00	2036	1.8	1832	1.2	1221
700	2.21	3062	1.99	2757	1.33	1843
800	2.42	4379	2.18	3945	1.45	2624
900	2.62	6000	2.35	5382	1.57	3596
1000	2.81	7945	2.53	7153	1.68	4750
1200	3.17	12906	2.85	11603	1.9	7736
1400	3.51	19451	3.16	17511	2.11	11693
1600	3.84	27794	3.45	24971	2.3	16647

slope 1.0%

200	1.36	154	1.22	138	0.81	92
250	1.57	277	1.42	251	0.94	166
300	1.78	453	1.6	407	1.07	272
350	1.97	682	1.77	613	1.18	409
400	2.15	973	1.94	878	1.29	584
500	2.5	1767	2.25	1590	1.5	1060
600	2.82	2870	2.54	2585	1.69	1720
700	3.13	4336	2.82	3907	1.88	2605
800	3.42	6189	3.08	5573	2.05	3709
900	3.7	8474	3.33	7626	2.22	5084
1000	3.97	11225	3.57	10094	2.38	6729
1200	4.48	18240	4.03	16408	2.69	10952
1400	4.97	27542	4.47	24771	2.98	16514
1600	5.43	39302	4.89	35394	3.26	23596

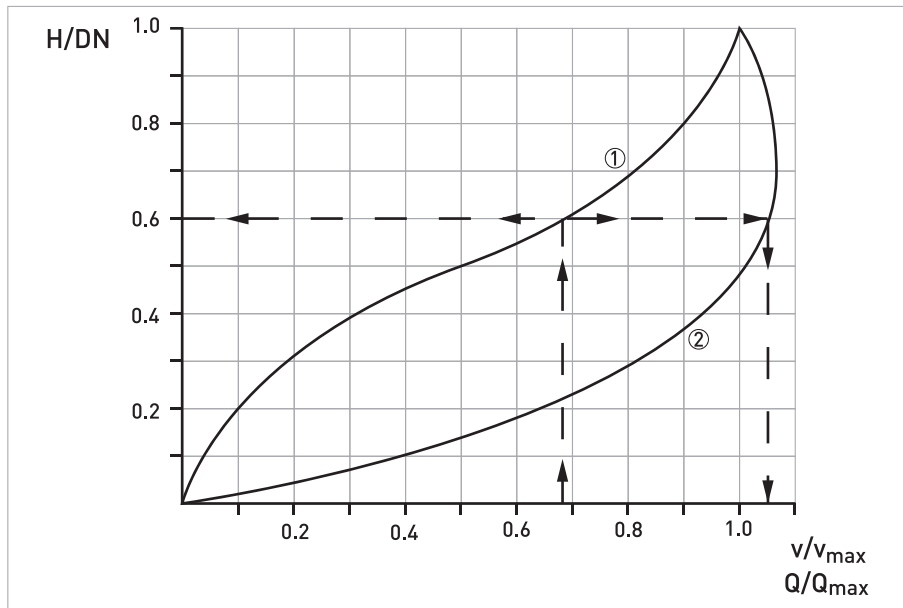

Figure 7-2: Relative flow and velocity versus relative filling level

- ① Flow Q
- ② Velocity v



INFORMATION!

v_{max} and Q_{max} are the values of v and Q if the pipe is completely filled

EXAMPLE:

Consider a maximum flow to be measured of $1200 \text{ m}^3/\text{h}$. The material of the pipeline is steel and the slope 1.0%.

From the table a maximum flow has to be selected that is bigger than the flow to be measured.
Selection: DN500, $Q_{max} = 1767 \text{ m}^3/\text{h}$ and $v_{max} = 2.5 \text{ m/s}$.

To determine the level in the pipe at $1200 \text{ m}^3/\text{h}$, calculated the ratio $Q / Q_{max} = 1200 / 1767 = 0.68$.
See above figure and read out the ratio's of H/DN and v/v_{max} :

- ① $H/DN = 0.6$ or $0.6 \times 500 \text{ mm} = 300 \text{ mm}$,
- ② At $H/DN = 0.6$, find $v/v_{max} = 1.05$, so $v = 1.05 \times 2.5 = 2.63 \text{ m/s}$.



INFORMATION!

A sizing tool for various slopes is available at the website of the manufacturer.

7.4 Dimensions and weights

The inner pipe diameter should match the inner diameter of the flowmeter. Since the inner diameter is not a standard DN size, choose the inner pipe diameter to be just a little bit bigger than the flow meter diameter. If a lot of sediment or fat is expected the optimal solution is to produce a diameter compensation ring on both sides to have smooth transits.

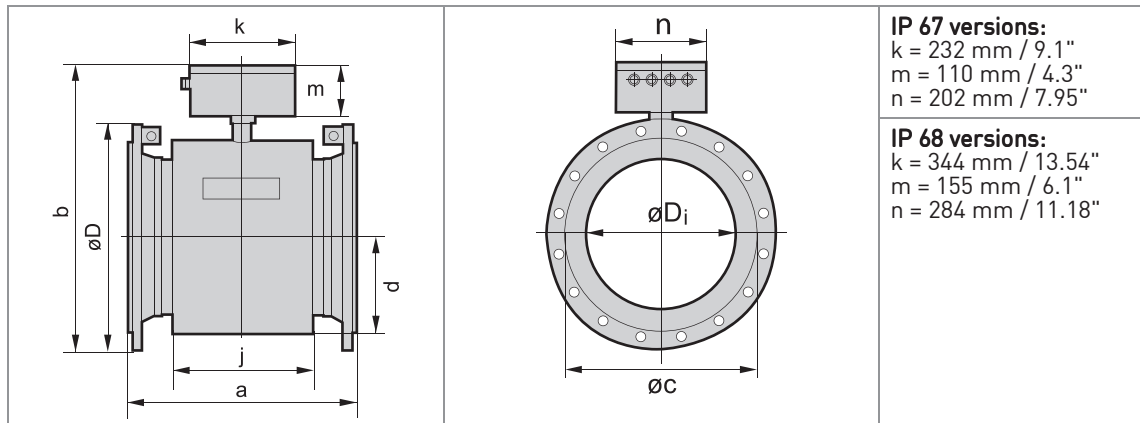

EN 1092-1

Nominal size		Dimensions [mm]								Approx. Weight [kg]
DN	PN	a	b		Øc	d	j	ØD	ØDi	
			IP 67	IP 68						
200	10	350	473	532	291	146	177	340	189	40
250	10	400	521	579	331	166	205	395	231	54
300	10	500	571	629	381	191	235	445	281	66
350	10	500	623	682	428	214	306	505	316	95
400	10	600	681	739	483	242	386	565	365	115
500	10	600	784	843	585	293	386	670	467	145
600	10	600	894	952	694	347	386	780	567	180
700	10	700	1010	1069	812	406	455	895	666	265
800	10	800	1125	1184	922	461	535	1015	768	350
900	10	900	1246	1305	1064	532	625	1115	863	425
1000	10	1000	1338	1396	1132	566	695	1230	965	520
1200	6	1200	1529	1588	1340	670	854	1405	1169	659
1400	6	1400	1732	1791	1521	761	1034	1630	1367	835
1600	6	1600	1932	1991	1721	861	1234	1830	1549	1659

150 lb flanges

Nominal size		Dimensions [inches]								Approx. weight [lb]
ASME ①	PN [psi]	a	b		Øc	d	j	ØD	ØDi	
			IP 67	IP 68						
8	284	13.78	19.02	20.9	11.46	5.75	6.97	13.39	7.44	90
10	284	15.75	21.06	22.8	13.03	6.54	8.07	15.55	9.09	120
12	284	19.69	23.54	24.8	15	7.52	9.25	17.52	11.06	145
14	284	27.56	25.43	26.8	16.85	9.8	12.05	19.88	12.44	210
16	284	31.5	27.72	29.1	19.02	9.53	15.2	22.24	14.37	255
20	284	31.5	31.73	33.2	23.03	11.54	15.2	26.38	18.39	320
24	284	31.5	36.14	37.5	27.32	13.66	15.2	30.71	22.32	400
28	Class D	35.43	40.4	42.7	31.97	15.98	17.87	36.50	26.22	692
32	Class D	39.37	45.2	47.5	36.3	18.15	21.06	41.75	30.24	1031
36	Class D	43.31	50.1	52.4	41.89	20.94	24.61	46.0	33.98	1267
40	Class D	47.24	53.8	56.1	44.57	22.28	27.36	50.75	37.99	1554
48	Class D	55.12	62.3	64.6	52.76	26.38	33.62	59.50	46.02	2242

① Nominal size ≤ 24": ASME; > 24": AWWA

7.5 Vacuum load

Diameter	Vacuum load in mbar abs. at a process temperature of	
[mm]	40°C	60°C
DN200...1600	500	600

Diameter	Vacuum load in psia at a process temperature of	
[inches]	104°F	140°F
8...64"	7.3	8.7

7.6 Measuring accuracy

The measuring accuracy for partly filled pipes and completely filled pipes are different. In these graphs it is assumed that the velocity at full scale value is at least 1 m/s (is also the standard value for calibration, since it will result in the most accurate measurements).

Fully filled pipes

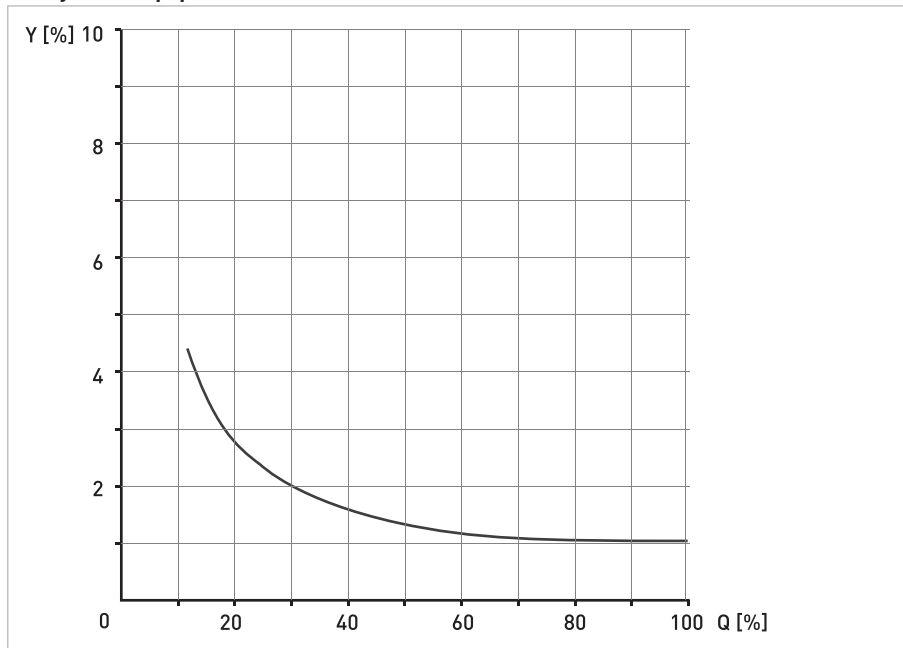

Figure 7-3: Maximum measuring error of measured value.

Partly filled pipes

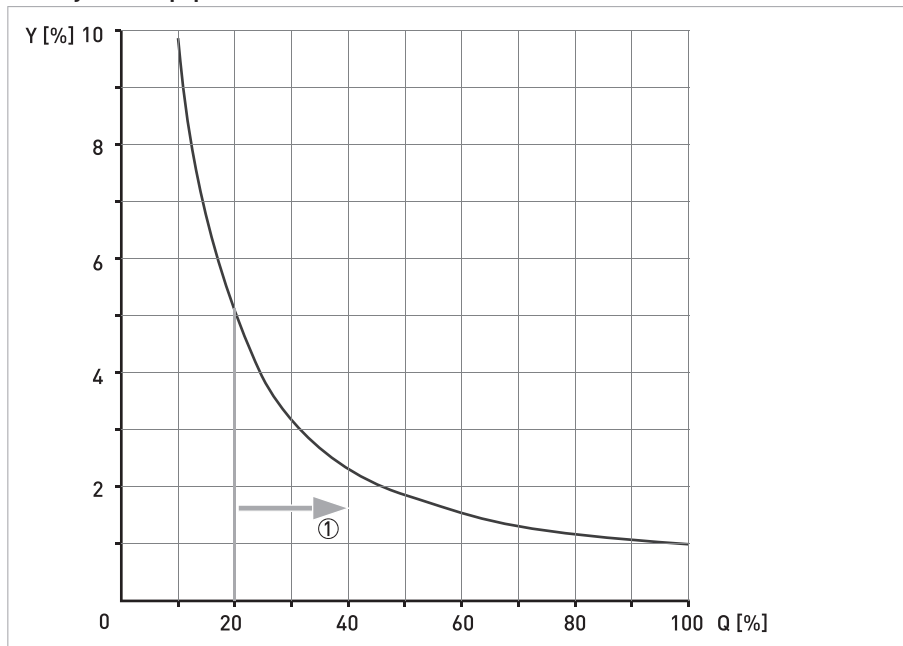

Figure 7-4: Maximum measuring error of measured value.

① Advised working area



KROHNE product overview

- Electromagnetic flowmeters
- Variable area flowmeters
- Ultrasonic flowmeters
- Mass flowmeters
- Vortex flowmeters
- Flow controllers
- Level meters
- Temperature meters
- Pressure meters
- Analysis products
- Measuring systems for the oil and gas industry
- Measuring systems for sea-going tankers

Head Office KROHNE Messtechnik GmbH
Ludwig-Krohne-Str. 5
D-47058 Duisburg (Germany)
Tel.: +49 (0)203 301 0
Fax: +49 (0)203 301 10389
info@krohne.de

The current list of all KROHNE contacts and addresses can be found at:
www.krohne.com

KROHNE