

Installation and operating instructions

VFM 3100 F-T VFM 3100 W-T

Vortex Flowmeter

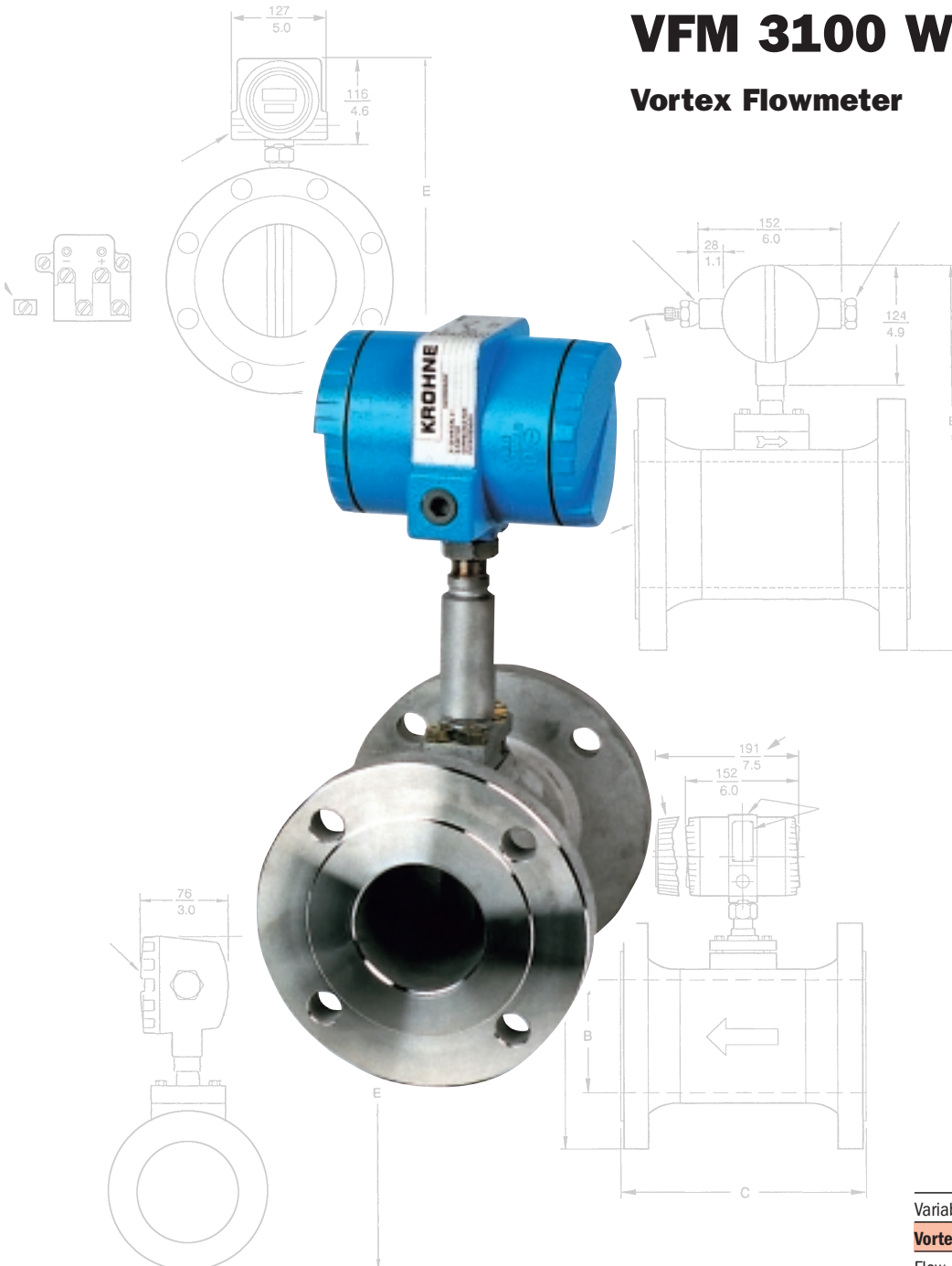

Variable area flowmeters

Vortex flowmeters

Flow controllers

Electromagnetic flowmeters

Ultrasonic flowmeters

Mass flowmeters

Level measuring instruments

Communications engineering

Engineering systems & solutions

Contents

1. Installation	6		
1.1. Introduction	6		
1.1.1. Description	6		
1.1.2. Fundamental Installation Requirements	6		
1.1.3. Standard Specifications	7		
1.1.4. Electrical Safety Specifications	8		
1.1.5. Unpacking	8		
1.1.6. VFM 3100 Identification	8		
1.2. Mechanical Installation	9		
1.2.1. Piping Considerations	9		
1.2.2. Installation Position	10		
1.2.3. Ambient Temperature	10		
1.2.4. Vibration	10		
1.2.5. Installation Procedure	12		
1.2.6. Repositioning the Electrical Housing	12		
1.2.7. VFM 3100 with Remote Electronic Module	13		
1.3. Field Termination	19		
1.3.1. Conduit Connections	19		
2. Operating the VFM 3100	22		
2.1. Introduction	22		
2.2. Passwords	22		
2.3. Configuration Database	22		
2.4. Changing the Configuration (Configuration Menu)	23		
2.4.1. Identification Parameters	23		
2.4.2. Transmitter Options	23		
2.4.3. Process Fluid Parameters	25		
2.4.4. Application Parameters	25		
2.4.5. Output Options	25		
2.5. Preconfiguring the VFM 3100	26		
2.6. Displaying the Configuration Database	26		
2.7. Adjusting the VFM 3100	26		
2.7.1. mA Calibration (D/A Trim)	26		
2.7.2. Total Reset	26		
2.7.3. Low Flow Cut-In	26		
2.7.4. Upper Range Value	26		
2.8. Reading the Measurements	26		
2.9. Testing the VFM 3100 and Loop (Test Menu)	26		
2.9.1. Self-Test	26		
2.9.2. Loop Test or Loop Calibration	26		
2.10. Electronic Module Replacement	26		
3. Troubleshooting	27		
3.1. General Troubleshooting	27		
3.1.1. VFM 3100 Has Incorrect Output	27		
3.1.2. VFM 3100 Output Indicates Flow When There Is No Flow	27		
3.1.3. VFM 3100 Output Indicates Higher Flow Rate with Decreasing Flow	27		
3.1.4. Fluctuating Output	27		
3.2. No Output Troubleshooting	27		
3.3. Module Test Procedure	28		
3.4. Preamplifier Test Procedure	28		
3.4.1. Extended Temperature Range Sensor	28		
3.4.2. Standard Temperature Range Sensor	28		
3.5. Sensor Test Procedure	29		
3.5.1. Standard Temperature Range Sensor	29		
3.5.2. Extended Temperature Range Sensor	29		
4. Maintenance	29		
4.1. Introduction	29		
4.1.1. Vortex Generation and Shedding	29		
4.1.2. Vortex Sensing	29		
4.1.3. Amplification, Conditioning and Processing	29		
4.2. Electronic Module	30		
4.2.1. Electronic Module Removal	30		
4.3. Electronic Module Replacement	33		
4.4. Preamplifier	34		
4.4.1. Preamplifier Removal	34		
4.4.2. Replacing the Preamplifier	35		
4.5. Post-Assembly Dielectric Test	37		
4.6. Sensor Replacement with Integral Electronic Module	37		
4.6.1. Disassembly	37		
4.6.2. Replacing the Sensor	38		
4.7. Sensor Replacement with Remote Electronic Module	41		
4.7.1. Disassembly	41		
4.7.2. Assembly	42		
5. Determining Special Measuring Units	43		
6. Isolation Valves	43		
6.1. Replacing the Sensor	43		
6.2. Replacing or Installing an Isolation Valve	44		
7. HART Configuration Instructions	45		
7.1. Introduction	45		
7.2. HART Menu Structure	45		
8. Local Configuration Instructions	49		
8.1. Introduction	49		
8.2. Using the Local Configurator	49		
8.2.1. Measurements (MEASURE)	49		
8.2.2. Display Bar Indicator	49		
8.2.3. Moving inside the Menu System	49		
8.2.4. Viewing Data (DISPLAY)	50		
8.2.5. Answering a Question	50		

8.2.6. Entering the Password	50
8.2.7. Activating an Edit, Pick-List or User Function Menu Block	50
8.2.8. Editing Numbers and Strings	50
8.2.9. Picking from a List	50
8.2.10. mA Calibration (TEST/CAL 4 mA or CAL 20 mA)	50
8.2.11. Transmitter Status	50
8.2.12. Changing the Password	50
8.3. Local Configurator Menu Tree	51
8.3.1. Reading the Menu Tree	51
8.4. Local Configurator Menu (1 through 8)	51
9. Configuration Database	59
9.1. Flowtube Parameters	59
9.2. Identification Parameters	59
9.3. Transmitter Options	60
9.4. Process Fluid Parameters	60
9.5. Application Parameters	61
9.6. Output Options	61

Figures

1	VFM 3100 F-T Flange Body	6	29	O-Ring/Sensor/Flow Dam	39
2	VFM 3100 W-T Sandwich Body	6	30	Electrical Housing/Mechanical Connector	39
3	VFM 3100 Identification	9	31	VFM 3100 Assembly	39
4	Typical Piping Configuration	9	32	Connector Bolt Torquing Sequence	40
5	Pressure and Temperature Tap Locations	10	33	Connector Bolt Torquing Sequence	40
6	VFM 3100 F Installation	12	34	Flowtube/Junction Box – Standard Temperature Range	41
7	VFM 3100 W Centering (using Spacers OR Sleeves)	12	35	Flowtube/Junction Box - Extended Temperature Range	41
8	Repositioning the Electrical Housing	13	36	VFM 3100 Assembly/Junction Box	42
9	Overall View of Remote Mounted VFM 3100	16	37	Sensor/Mechanical Connector/Junction Box	42
10	Electronics Housing	19	38	Isolation Valve	44
11	Installation Wiring - 4-20 mA Output (Two-wire)	20	39	Dual Manifold	45
12	Load Requirements	20	40	HART On-Line Menu Structure	46
13	Installation Wiring - Pulse Output (Three-wire)	21	41	Fast-Key Function/Variable Chart	48
14	Installation Wiring (Four-wire)	21	42	Local Configurator Menu	51
15	Normal Vortex Frequency Waveform	29			
16	VFM 3100 Block Diagram	30			
17	Electronic Module Connections - Standard Temperature Range (Integral Mount)	31			
18	Electronic Module Connections - Extended Temperature Range	31			
19	Electronic Module with Display Connections	32			
20	Electronic Module Connections - CENELEC Certified Extended and Standard Temperature Range	32			
21	Electronic Module - CENELEC Certified Flameproof	33			
22	Preamplifier Assembly - Integral Mount Extended Temperature Range	34			
23	Preamplifier Assembly - Remote Mount Assembly	34			
24	Preamplifier - Remote Mounted VFM 3100 (CENELEC Certified Flameproof)	35			
25	Preamplifier Assembly	36			
26	Preamplifier - Remote Mounted VFM 3100	37			
27	Connections for Post-Assembly Dielectric Test	37			
28	VFM 3100 Assembly	38			

Tables

1	Standard Specifications	7
2	Electrical Safety Specifications	8
3	VFM 3100 Mounting Arrangements	11
4	Preparation of Remote Signal Cable	14
5	Preparation of Remote Signal Cable (Electronics End)	15
6	Connection of Remote Signal Cable	17
7	Connection of Remote Signal Cable (Electronics End)	18
8	Configuration Database	22
9	User Information	22
10	Electronic Module Terminal Block Connections	30
11	Maximum Test Pressure	40
12	Menu Tree Functional Overview	49
13	Configuration Database	59

1. Installation

1.1 Introduction

1.1.1 Description

The VFM 3100 F/W-T (Figures 1 and 2) measure fluid (liquid, gas, or steam) flow rates using the principle of vortex shedding. Fluid flowing through the VFM 3100 body passes a specially shaped vortex shedder that causes vortices to form and shed alternately from the sides of the shedder at a rate proportional to the flow rate of the fluid. These shedding vortices create an alternating differential pressure that is sensed by a detector located above the shedder. A pulsed voltage is generated by the detector with a frequency that is synchronous with the vortex shedding frequency. This voltage is then conditioned by the electronic module to produce either a pulse rate signal or an analog (4 to 20 mA dc) signal.

1.1.2 Fundamental Installation Requirements

Meters shall be installed to meet all applicable local installation regulations, such as hazardous location requirements, electrical wiring codes, and mechanical piping codes. Persons involved in the installation should be trained in these code requirements in order to ensure that the installation takes maximum advantage of the safety features designed into the VFM 3100.



Figure 1. VFM 3100 F-T Flange Body



Figure 2. VFM 3100 W-T Sandwich Body

1.1.3. Standard Specifications

Table 1.

Item	Specification
Process Temperature Limits	-20 and +430 °C (0 and 800 °F) ^(a)
Ambient Temperature Limits	-40 and +85 °C (-40 and +185°F)
Power Supply Requirements: Supply Voltage Limits Supply Current	12,5 and 42 V dc 22 mA dc
Product Safety Specification	Refer to instrument data plate for type of certification and observe applicable wiring requirements. Electrical certifications and conditions of certification are listed on page 8.
Flow Rate Requirements	Rd = 5000 minimum: Automatic compensation for the non-linear behavior of vortex shedding in the Rd range 5000 to 20000 is built into the VFM 3100. This compensation requires the user to input values for the flowing density and viscosity.
Static Pressure Limits	Full vacuum to pressure rating of mating flanges with maximum operative limit of 10 MPa (1500 psi: 100 bar or kg/(cm ²) at 24°C (75°F).
VFM 3100 Output Analog Digital (HART) Scaled Pulse	4 to 20 mA dc into a maximum of 1450 ohms depending on power supply (refer to graph in Figure 12). Digital signal conveyed at a 1200 baud transmission rate. HART protocol. Isolated 2 wire „contact closure”. Pulse rate (0 to 100 Hz) proportional to volumetric flow rate.
Scaled Pulse Output Specifications	<ul style="list-style-type: none"> • Isolated 2-wire contact-closure • Applied voltage limits: 12.5 Vdc minimum 42.0 Vdc maximum • Maximum „ON” state voltage drop: 0.5 Vdc • Maximum „ON” state current: 250 mA • Update rate: 4 Hz • Maximum „OFF” state leakage current: 0.10 mA @ 12.5 Vdc 0.25 mA @ 24.0 Vdc 0.42 mA @ 42.0 Vdc • 250 mA short circuit protected • Reserve polarity protected
Signal Output Combinations	2-Wire Hook-Up 4-20 mA and HART (1200 baud) 3-Wire Hook-Up 4 to 20 mA, HART (1200 baud) and Scaled Pulse 4-Wire Hook-Up 4 to 20 mA, HART (1200 baud) and Scaled Pulse

(a) Maximum temperature limit is a function of sensor type.

1.1.4. Electrical Safety Specifications

Table 2.

Testing Laboratory, Type of Protection, and Area Classification	Application Conditions
CSA intrinsically safe for Class I, Division I, Groups A, B, C, D; Class II, Division I, Groups E, F, G; and Class III, Division I	Temperature Class T3C at 85°C and T4A at 40°C maximum ambient. Limited to Gas Groups C and D when connected to 33 V, 185 Ω Zener barrier.
CSA explosionproof for Class I, Division I, Groups C and D; dust-ignitionproof for Class II and III, Division I, Groups E, F, and G; and Class III, Division I. Suitable for Class I, Division 2, Groups A, B, C, D; class II, Division 2, Groups F, G; and Class III, Division 2.	Temperature Class T5.
FM intrinsically safe for Class I, II and III, Division 1, Group A, B, C, D, E, F, and G; nonincendive Class I, II and III, Division 2, Groups A, B, C, D, F, and G.	Temperature Class T3C at 85°C and T4A at 40°C maximum ambient.
FM explosionproof for Class I, Division 1, Groups C and D; dust-ignitionproof for Class II and III, Division 1, Groups E, F, and G; nonincendive Class I, II and III, Division 2, Groups A, B, C, D, F, and G.	Temperature Class T5.
CENELEC intrinsically safe for EEx ib, Gas Group IIC, Zone 1.	Temperature Class T4 at 0.8 W. Temperature Class T5 at 0.5 W. Temperature Class T6 at 0.3 W.
CENELEC flameproof for EEx d (ib), Gas, Group IIC, Zone 1	Temperature Class T6.

NOTE: These transmitters have been designed to meet the electrical safety descriptions listed in the table above. For detailed information or status of testing laboratory approvals/ certifications, contact KROHNE.

1.1.5. Unpacking

The VFM 3100 is built to be durable, but it is part of a calibrated precision system and should be handled as such.

NOTE: VFM 3100 may (depending on pressure rating of flanges with which they will be used) have a set of centering spacers included. Do not discard these centering spacers. They must be used to install the VFM 3100 properly.

VFM 3100 with remote-mounted electronics are rugged two-piece units. A remote cable connection is assembled to the VFM 3100 junction box and electronics housing. The cable may be cut to the required length per instructions beginning on page 13. Do not allow the weight of either the flowtube or electronics housing to be supported by the remote cable.

Remove the flowtube from the shipping carton using care to avoid dropping or otherwise subjecting it to impact, particularly at the flange or wafer faces. Never put anything through the flowtube for lifting purposes as damage to the shedder bar may occur.

After removing the flowtube from its shipping carton, inspect it for visible damage. If any damage is observed, notify the carrier immediately and request an inspection report. Obtain a signed copy of the report from the carrier. The calibration certificate and any other documentation shipped with the VFM 3100 should be separated from the packing material and held for future reference. Re-install any flange covers or protective material to safeguard the VFM 3100 until it is installed.

Packing material should be disposed of in accordance with local regulations. All packing material is non-hazardous and is generally acceptable to landfills.

1.1.6. VFM 3100 Identification

The model code is stamped on the data plate as shown in Figure 3 and is digitally readable from the configuration menu.

The Standard Temperature Range sensor is made of 316 stainless steel and is filled with silicone oil, maximum temperature 200 °C (400 °F). An optional fill is Fluorolube, maximum temperature 90 °C (200 °F). The Extended Temperature Range sensor is made of 316 stainless steel and is unfilled, maximum temperature 430 °C (800 °F). Both standard and high temperature sensors are available made from Hastelloy.

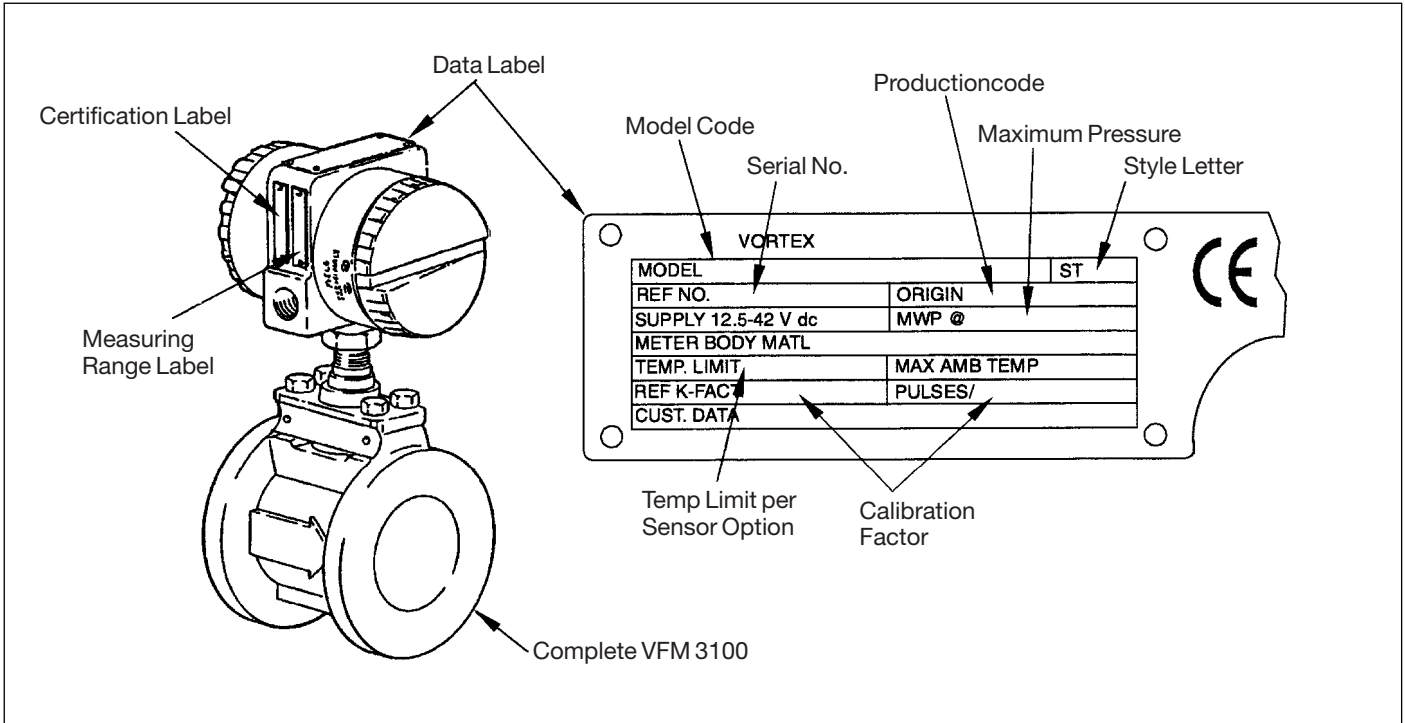

Figure 3. VFM 3100 Identification

1.2. Mechanical Installation

There are two mounting arrangements: integral and remote. The following sections deal with both the integral and remote VFM 3100 arrangements.

1.2.1. Piping Considerations

Effects of Piping on VFM 3100 Performance

The flange size of the adjoining pipe must be the same nominal size as the VFM 3100. Flanges with a smooth bore, similar to weld neck flanges, are preferred.

Normal performance data is based on the use of Schedule 40 piping upstream and downstream of the VFM 3100. If this is not the case, the actual schedule must be selected from a picklist during configuration and the distance to the disturbance in pipe diameters entered. This enables the VFM 3100 to automatically compensate for any induced flow effects.

In addition, the bore of the pipe (flange) and VFM 3100 must be aligned (see "Installation Procedure" on page 12), and the flange gaskets installed such that they do not protrude into the flow stream.

NOTE: 1. VFM 3100 mounted near pump discharge or suction lines may be exposed to oscillatory flow that may affect vortex shedding or product pipe vibration. Also, VFM 3100 mounted near the discharge of a liquid positive displacement pump or near oscillating control valves may experience severe flow fluctuations that could damage the sensor. To avoid these adverse situations, install the VFM 3100 at least 20 feet or 40 pipe diameters, whichever is larger, from the disturbance in question.

2. It is good piping practice that the internal surface of the pipe shall be free from mill scale, pits, holes, reaming scores, rifling, bumps, or other irregularities for four pipe diameters upstream and two pipe diameters downstream of the VFM 3100.

Consideration for VFM 3100 Repair

When installing the VFM 3100, consider VFM 3100 repair. The VFM 3100 should be accessible for servicing. If the flow cannot be interrupted to replace a sensor, then an isolation manifold should be mounted on the VFM 3100 before it is installed.

An acceptable and recommended practice is to install bypass piping so that the entire VFM 3100 may be removed for servicing (see Figure 4).

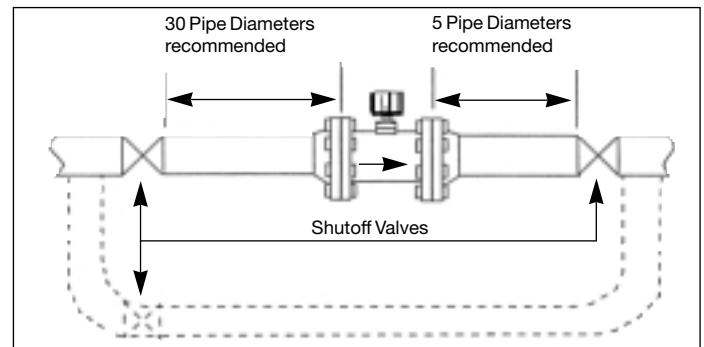

Figure 4. Typical Piping Configuration

Liquid Control Installations

It is recommended for liquid flow that the VFM 3100 be mounted upstream at least 5 pipe diameters from the control valve and in vertical installations in the upward flowing leg. This will help to maintain a full pipe and ensure that there is sufficient back pressure to prevent flashing or cavitation.

Gas Control Installations

For gas control installations, there are choices for VFM 3100 location that should be considered. For maximum rangeability, locate the VFM 3100 30 or more pipe diameters downstream from a control valve. This will assure maximum velocity at the VFM 3100 and produce the most efficient signal from the sensor.

When the flow is more stable, the VFM 3100 may be mounted a minimum of 5 pipe diameters upstream of the control valve. Pressure fluctuations often are less on the upstream side of a control valve.

This should be considered as a means to provide the most accurate density when a flow computer is not used.

The VFM 3100 electronics automatically calculates the effect of upstream piping on K-factor when installation piping data is entered by user.

Steam Control Installations

For steam control installations, it is recommended that the VFM 3100 be mounted 30 pipe diameters or more downstream of the control valve. This is particularly useful when measuring saturated steam to ensure that there is a minimum amount of condensate present at the VFM 3100.

Pressure and Temperature Taps

NOTE: The inside of the pipe at the pressure and temperature taps must be free of burrs and obstructions.

Pressure Taps -- For density measurement (when required), locate the tap 3-1/2 to 4-1/2 pipe diameters DOWNSTREAM of the VFM 3100. See Figure 5.

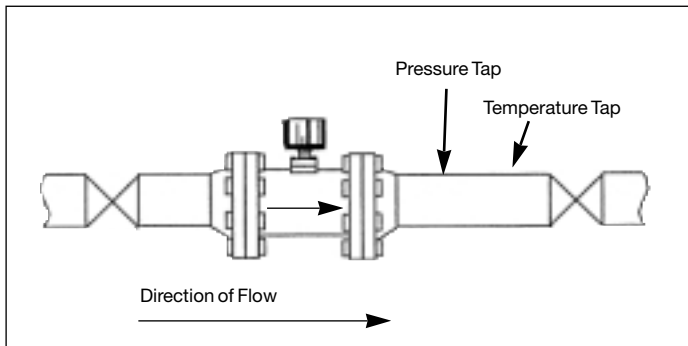

Figure 5. Pressure and Temperature Tap Locations

NOTE: On a gas installation, the pressure tap should be located on the top of the pipe. On a liquid installation, the pressure tap (if required) should be located on the side of the pipe. On a steam installation, the pressure tap should be located on the top when the pressure measuring device (typically a pressure transmitter) is above the pipeline, and on the side when the measuring device is below the pipeline. With vertical piping, the pressure tap may be located anywhere around the circumference of the pipeline.

Temperature Taps -- For temperature measurement (when required), locate the tap 5 to 6 pipe diameters DOWNSTREAM of the VFM 3100. The smallest possible probe is recommended to reduce flow disturbance. See Figure 5.

1.2.2. Installation Position

For optimal performance the locations of the sensor and integral electronics relative to the piping must be considered. Factors that influence this decision include process fluid type, ambient temperature, and vibration.

Process Fluid

When using:

Saturated Steam: The electronics housing should be below the VFM 3100 body, so that the sensor cavity remains filled with condensate.

NOTE: A VFM3100 used on steam should be located downstream of a control valve. See "Steam Control Installations."

Superheated Steam: The electronics housing should be below the VFM 3100 body when the steam has less than 10 °F (5.6 °C) superheat. The housing should be above the VFM 3100 body when the superheat is more than 10 °F and no condensate will be forming on the sensor. An isolation valve may be used in superheated steam applications with adequate insulation.

Gas: The electronics housing may be above or below the VFM 3100 body. The normal recommended position of the electronics housing is above the VFM 3100 body.

Liquid: For a liquid with solid particles, the electronics housing should be above the VFM 3100 body. Care should be taken so that entrapped air does not accumulate in the sensor cavity. For a clean liquid, the electronics housing may be mounted below the VFM 3100 body. Care must be taken if there is any sediment or fine dirt, that the particles do not accumulate in the sensor cavity. A VFM 3100 used on liquid should be mounted upstream from a control valve.

VFM 3100 may also be mounted with the electronics housing positioned to the side. This ensures escape of entrapped air and minimizes sediment accumulation.

The above considerations are summarized in Table 3 for single and dual measurement VFM 3100 with and without isolation valves.

1.2.3. Ambient Temperature

Ambient temperature limits must be observed per specifications. However, if the electronic housing is above the ambient temperature limit (85 °C, 185 °F), the VFM 3100 may be mounted with the electronic housing located to the side to aid the cooling of the electronic module. The bottom conduit connection should be used (the top one plugged) to avoid possible accumulation of condensate at the terminal block.

1.2.4. Vibration

The vortex shedder axis should be oriented to reduce or, in some cases virtually eliminate, vibration influence. Positioning VFM3100 so that vibrations are parallel to sensor diaphragms will minimize effect of vibrations.

Table 3. VFM 3100 Mounting Arrangements

Single Measurement (with and without isolation valves)

Housing Above Pipe

- GAS** Recommended mounting.
- STEAM** Recommended for super-heated steam with adequate insulation. Not recommended for saturated steam.
- LIQUID** Adequate self-purging. Recommended mounting. Isolation Valve may cause temporary start-up error due to entrapped air.

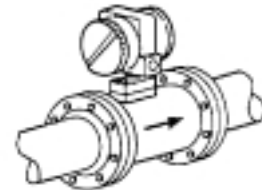

Vertical Pipe

- GAS** Recommended mounting.
- STEAM** Recommended for super-heated steam with adequate insulation. Not recommended for saturated steam.
- LIQUID** Adequate self-purging. Recommended mounting.

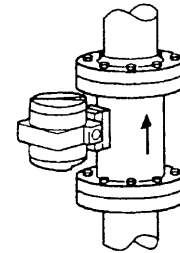

Housing Below Pipe

- GAS** Recommended for clean applications only.
- STEAM** Not recommended for super-heated steam. Recommended for saturated steam.
- LIQUID** Recommended when self-purging is important.

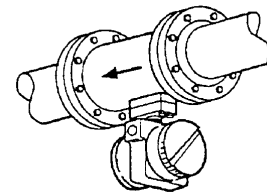

Housing Beside Horizontal Pipe

- GAS** Recommended mounting.
- STEAM** Not recommended for saturated steam. Recommended for superheated steam provided the pipe is adequately insulated.
- LIQUID** Adequate self-purging, recommended mounting.

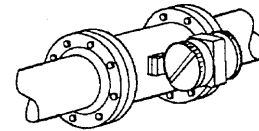

Housing to the Side and Below Horizontal Pipe

Note: Requires flanges with eight or more bolts

- GAS** Not recommended
- STEAM** Not recommended
- LIQUID** Recommended.

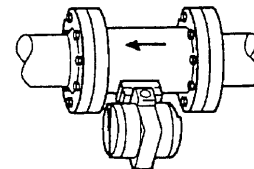

Dual Measurement (with or without isolation valves)

Housing Above Pipe

- GAS** Recommended mounting.
- STEAM** Recommended for super-heated steam with adequate insulation. Not recommended for saturated steam.
- LIQUID** Not self-purging. May cause errors at startup. Not recommended for batch operations.

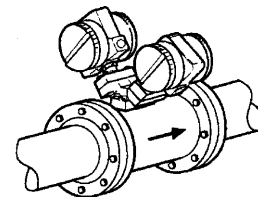

Vertical Pipe

- GAS** Recommended mounting.
- STEAM** Recommended for super-heated steam with adequate insulation. Not recommended for saturated steam.
- LIQUID** Adequate self-purging. Recommended mounting.

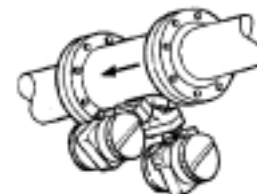

Housing Below Pipe

- GAS** Not recommended.
- STEAM** Not recommended for super-heated steam. Recommended for saturated steam.
- LIQUID** Self-purging. Recommended for batch operations.

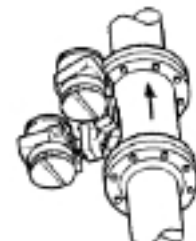

1.2.5. Installation Procedure

VFM 3100 F–Flanged Body

- Gaskets are required and must be supplied by the user. Select a gasket material suitable for the process.
- Insert gaskets between body of VFM 3100 and adjacent flanges. See Figure 6. Position gaskets so that ID of each gasket is centered on ID of VFM 3100 and adjacent piping.

CAUTION:

- Verify that the ID of the gaskets is larger than that of the VFM 3100 bore and pipe and that they do not protrude into the VFM 3100 entrance or exit. Accuracy of the measurement will be affected.
- Gaskets will not prevent flanges from being wetted by process fluids.

NOTE: When installing new flanges in the process piping and the VFM 3100 is used as a gauge to set the flanges, the inside diameter of the VFM 3100 must be protected from weld splatter. It is recommended that a solid sheet of gasketing be installed at each end of the VFM 3100 during welding. Remove this sheet and install flange gasket after welding. Remove any splatter in either the pipe or the VFM 3100 as this could affect VFM 3100 accuracy.

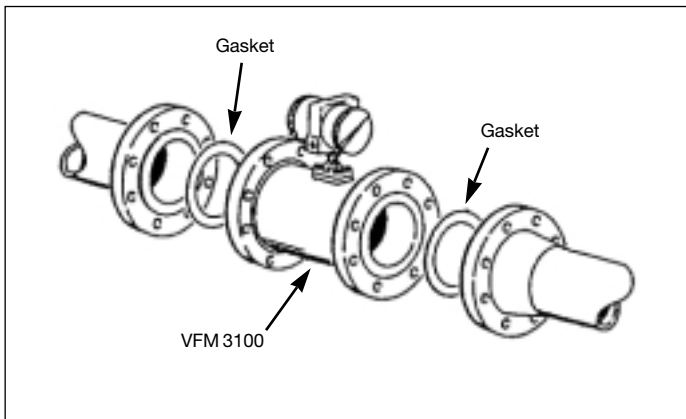

Figure 6. VFM 3100 F Installation

- Visually inspect for concentricity of mating flanges.
- Tighten bolts in accordance with conventional flange bolt tightening practice (i.e., incremental and alternate tightening of bolts).

VFM 3100 W– Sandwich Body

For optimal performance, the sandwich body VFM 3100 should be centered with respect to the adjoining pipe. Normally, this requires the use of centering fixtures that are supplied with the VFM 3100.

NOTE: Centering fixtures are not required for meters with ANSI Class 150 flanges.

Two types of centering fixtures are presently in use; the older centering sleeves and the newer hex-nut spacers. The VFM 3100 may come with either type of fixture. Most meter sizes have two centering fixtures (two sets in the case of the hex-nut spacers), but some larger sizes may have twice this number, two for each side.

- See Figure 7. Insert the first stud through the downstream flange at one of the lower holes, through the centering sleeves or two hex-nut spacers, and then through the upstream flange. Place the nuts on both ends of the stud but do not tighten.

- Using the remaining centering sleeve or hex-nut spacers, repeat Step 1 at the lower hole adjacent to the first.
- Set the VFM 3100 between the flanges. For centering with the hex-nut spacers, rotate spacers to the thickness that centers the VFM 3100.

NOTE: By rotating the hex-nut spacers to the correct thickness, you can center the VFM 3100 to any type of flange.

- Gaskets are required and must be supplied by the user. Select a gasket material suitable for the process fluid.
- Insert gaskets between body of VFM 3100 and adjacent flanges. Position gaskets so that ID of each gasket is centered on ID of VFM 3100 and adjacent piping.

CAUTION: Verify that the ID of the gaskets is larger than that of the VFM 3100 bore and pipe and that they do not protrude into the VFM 3100 entrance or exit.

NOTE: If welding of flanges to the process piping is required, protect the VFM 3100 from weld splatter, which could affect VFM 3100 accuracy. It is recommended that a solid sheet of gasketing be installed at each end of the VFM 3100 during welding. Remove this sheet and install flange gasket after welding.

- Visually inspect for concentricity of mating flanges.
- Install the rest of the studs and nuts and tighten the nuts in accordance with conventional flange bolt tightening practice (i.e., incremental and alternate tightening of bolts).

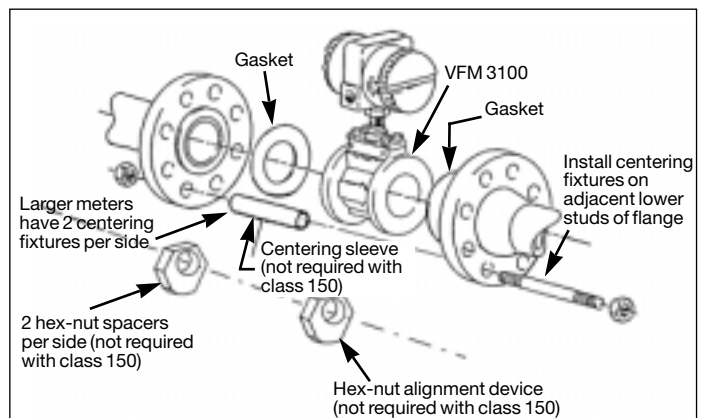

Figure 7. VFM 3100 W Centering (using Spacers OR Sleeves)

1.2.6. Repositioning the Electrical Housing

The VFM 3100 housing may be repositioned up to a maximum of 270°C from its original position by rotating the electrical housing.

WARNING: Stops are incorporated in the housing design. Do not remove the stops as further rotation from the 270°C maximum may cause damage to the sensor wires. Additionally this may violate safety code requirements for explosion-proof thread engagement in hazardous locations.

- Unscrew housing locknut to bottom of thread. See figure 8.
- Square locking plate should slip down on shaft. If it does not, pry out with scwdriver.
- Rotate electrical housing to desired position. See Warning on page 12.
- Note recess on bottom of electrical housing into which the locking plate fits. Screw the locking nut hand tight making sure locking plate fits into recess on bottom of electrical housing.
- Secure the locknut firmly using a wrench.

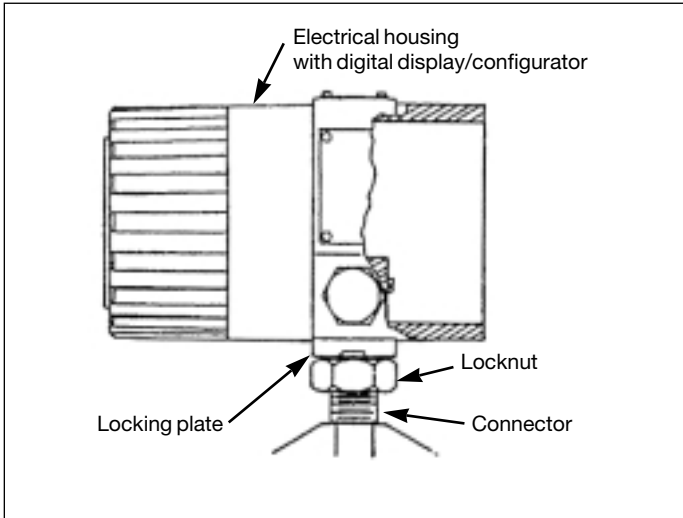

Figure 8. Repositioning the Electrical Housing

1.2.7. VFM 3100 with Remote Electronic Module

The purpose of the remote electronic module is to allow for separation of the VFM 3100 body and the electronics housing. This VFM 3100 consists of:

- An electronics housing mounted to a pipe or wall mounting bracket with up to 15 m (50 ft) of interconnecting cable attached.
- A VFM 3100 body with junction box. The junction box contains a preamplifier assembly. Refer to Figure 9.
- 1/2 NPT conduit connections are provided on both the housing and the junction box.

NOTES:

- *Mount the VFM 3100 so that the junction box is serviceable.*
- *The cable is prewired to the junction box to ensure proper grounding of the shield. It is recommended not to disconnect the cable from the junction box.*
- *If the cable must be disconnected, make sure the end labeled "VFM 3100 End" is positioned at the junction box end.*
- *If the cable is to be shortened, refer to Table 2 for re-dressing cable ends.*

Installing the Remote Electronics

WARNING: For optimum VFM 3100 performance, the remote signal cable must be prepared and connected following the procedures outlined below.

To install the remote electronics as shipped, execute the following procedure:

- Mount the VFM 3100 as described in the preceding section. Be sure to mount the VFM 3100 so that the junction box is serviceable.
- Mount the housing. The bracket assembly supplied with the housing may be mounted directly to a wall or to a 2-inch pipe stand.
- Mount the housing close enough to the VFM 3100 so that the supplied cable will reach between the VFM 3100 and the housing.

To install remote electronics that must be separated, disconnect the remote signal cable at housing end as described below.

It is not recommended that you disconnect the VFM 3100 end (junction-box end).

- Remove electronic compartment threaded cover.
- Unscrew the two captive screws, one on each side of the electronic module.
- Pull out electronic module far enough to disconnect the remote signal cable.
- Disconnect the four remote signal wires from the four position terminal block on rear of the electronic module. See Figure 9.
- Unscrew knurled nut, pull it back onto cable jacket, also pull rubber bushing onto the cable jacket. Leave these parts on the cable jacket as they will be used when reconnecting the cable.
- Mount the VFM 3100 as described in the preceding section. Be sure to mount the VFM 3100 so that the junction box is serviceable.
- Mount the housing close enough to the VFM 3100 so that the supplied cable will reach between the VFM 3100 and electronic housing.
- Mount the electronic housing. The bracket assembly supplied with the housing may be mounted directly to a wall or a 2-inch pipe stand.

Interconnection Wiring for Remote Electronics

Installation without Conduit:

If the VFM 3100 and electronic housing were NOT separated during installation, the interconnection wiring is complete.

NOTE: *Oxygen cleaned meters are shipped separated.*

If Housing End Is Disconnected:

If the VFM 3100 and electronic housing were separated during installation, follow the procedures below for interconnection wiring.

- Make sure the knurled nut and rubber bushing are on the cable jacket. Orient the cable so that the end labeled "VFM 3100 End" is positioned at the VFM 3100 junction box and the "Electronics End" is positioned at the remote electronics housing.
- If the pre-dressed cable does not look as shown in Table 6, prepare it following the instructions for dressing electronic housing end of remote signal cable in Table 6 on page 17.
- Take the prepared cable, taking care not to damage the copper braid, and push it into the connector at bottom of the electronic housing, as shown in Step 1 of Table 6 on page 17 until it comes to a stop.
- Ensure that the remote signal cable is pushed in all the way, until the outer jacket bottoms out inside the connector. Push the rubber bushing into position, until it sits snug inside the connector, as shown in Step 2 of Table 6 on page 17.
- Tighten the knurled nut on the connector to create a compression fit for a good seal.
- Inside the electronic housing, connect the four remote signal wires to the color coded 4-position terminal block on the rear of the electronic module. See Figure 9 on Page 16.
- Ensure that the remote signal and loop power wires are tucked under the electronic module. Taking care not to pinch the wires, place the module in housing over mounting screws. Tighten the two captive mounting screws.
- Replace threaded housing cover tightly. This will prevent moisture or other contaminants from entering the compartment.

For installations where the provided pre-dressed remote signal cable is not used, both ends of the cable being used must be prepared per the instructions in Tables 4 and 5 of document. The cable must be connected at both ends per instructions on Tables 6 and 7 on Pages

17 and 18. Terminate wires at J-Box following Figure 9 on Page 16. At housing end, wires should be terminated at 4-position terminal block on rear of electronic module as shown in Figure 9.

Table 4. Preparation of Remote Signal Cable

VFM 3100 End (Junction Box End) Procedures	
<p>1. Slide the knurled nut and then the rubber bushing onto outer jacket of cable as shown at right. Next, remove outer polyethylene jacket of cable to dimension shown.</p>	
<p>2. Cut and remove braided copper shield to dimension shown at right. This will expose the barrier (plastic) tape and foil mylar that encloses the conductors.</p>	
<p>3. Cut and remove the barrier tape, foil mylar and fillers to dimension shown at right. This will expose two twisted pairs of conductors (brown-yellow, orange-red) and an uninsulated drain wire. The barrier tape under the copper braid prevents the drain wire from shorting to the copper braid shield.</p>	
<p>4. Trim the uninsulated drain wire to dimension shown at right. To expose bare conductors for termination, cut and strip ends of the two twisted pairs to dimension shown.</p>	
<p>5. Fold drain wire back onto the copper braid as shown at right. Label outer cable jacket „VFM 3100 End” to avoid confusion during installation. Cable is now ready for installation.</p>	

Table 5. Preparation of Remote Signal Cable (Electronics End)

Electronics End (Electronic Housing End) Procedures	
<p>1. Slide the knurled nut and then the rubber bushing onto outer jacket of cable as shown at right. Next, remove outer polyethylene jacket of cable to dimension shown.</p>	<p>Labels: Knurled nut, Rubber bushing, Copper braid, Outer polyethylene jacket. Dimension: 203 mm (8.0 in).</p>
<p>2. Cut and remove braided copper shield to dimension shown at right. This will expose the barrier (plastic) tape and foil mylar that encloses the conductors.</p>	<p>Labels: Knurled nut, Rubber bushing, Copper braid, Barrier tape and foil mylar, Outer polyethylene jacket. Dimensions: 25 (1.0), 178 mm (7.0 in).</p>
<p>3. Cut and remove the barrier tape, foil mylar and fillers to dimension shown at right. This will expose two twisted pairs of conductors (brown-yellow, orange-red) and an uninsulated drain wire. The barrier tape under the copper braid prevents the drain wire from shorting to the copper braid shield.</p>	<p>Labels: Knurled nut, Rubber bushing, Copper braid, Barrier tape and foil mylar, Outer polyethylene jacket, Two twisted pairs, Uninsulated drain wire. Dimensions: 25 (1.0), 40 (1.5).</p>
<p>4. Cut off drain wire at end of barrier tape and foil mylar as shown at right. It is not used at this end.</p>	<p>Labels: Knurled nut, Rubber bushing, Copper braid, Barrier tape and foil mylar, Outer polyethylene jacket, cut off here, Two twisted pairs.</p>
<p>5. Apply shrink tubing or electrical tape to end of barrier tape and foil mylar at location shown at right. Note that the shrink tube or tape covers end of barrier tape and mylar as well as a portion of the 2 twisted pairs of wires. This will prevent the barrier tape and foil mylar from unwrapping.</p>	<p>Labels: Copper braid do not tape, Barrier tape and foil mylar, Two twisted pairs, Outer polyethylene jacket, Rubber bushing, Shrink tube or electrical tape, Knurled nut. Dimensions: .5 to .75 in, 32 (1.25).</p>
<p>6. Cut and strip ends of the two twisted pairs to dimension shown at right. Label outer cable jacket "Electronic End" to avoid confusion during installation. Cable is now ready for installation.</p>	<p>Labels: Barrier tape and foil mylar, Two twisted pairs, Copper braid do not tape, Electronic end, Label cable jacket, Rubber bushing, Shrink tube or electrical tape, Knurled nut, cut and strip 4 places. Dimension: 6.4 (.25).</p>

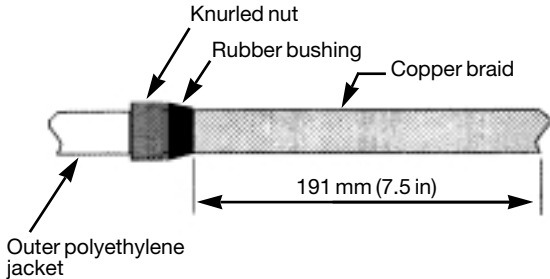
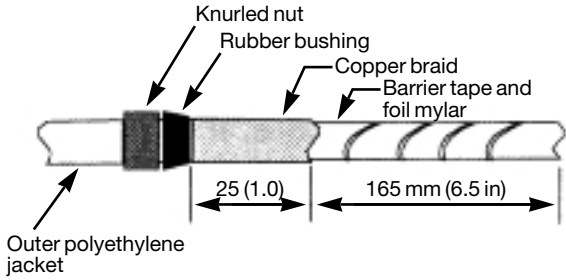
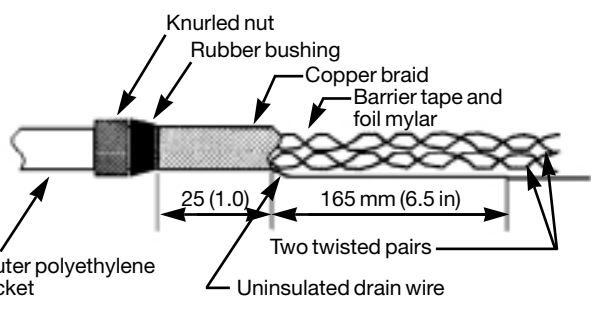
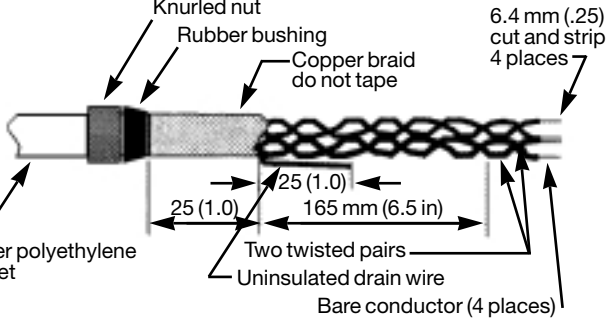
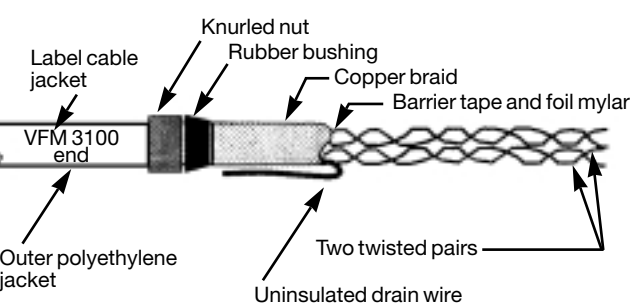
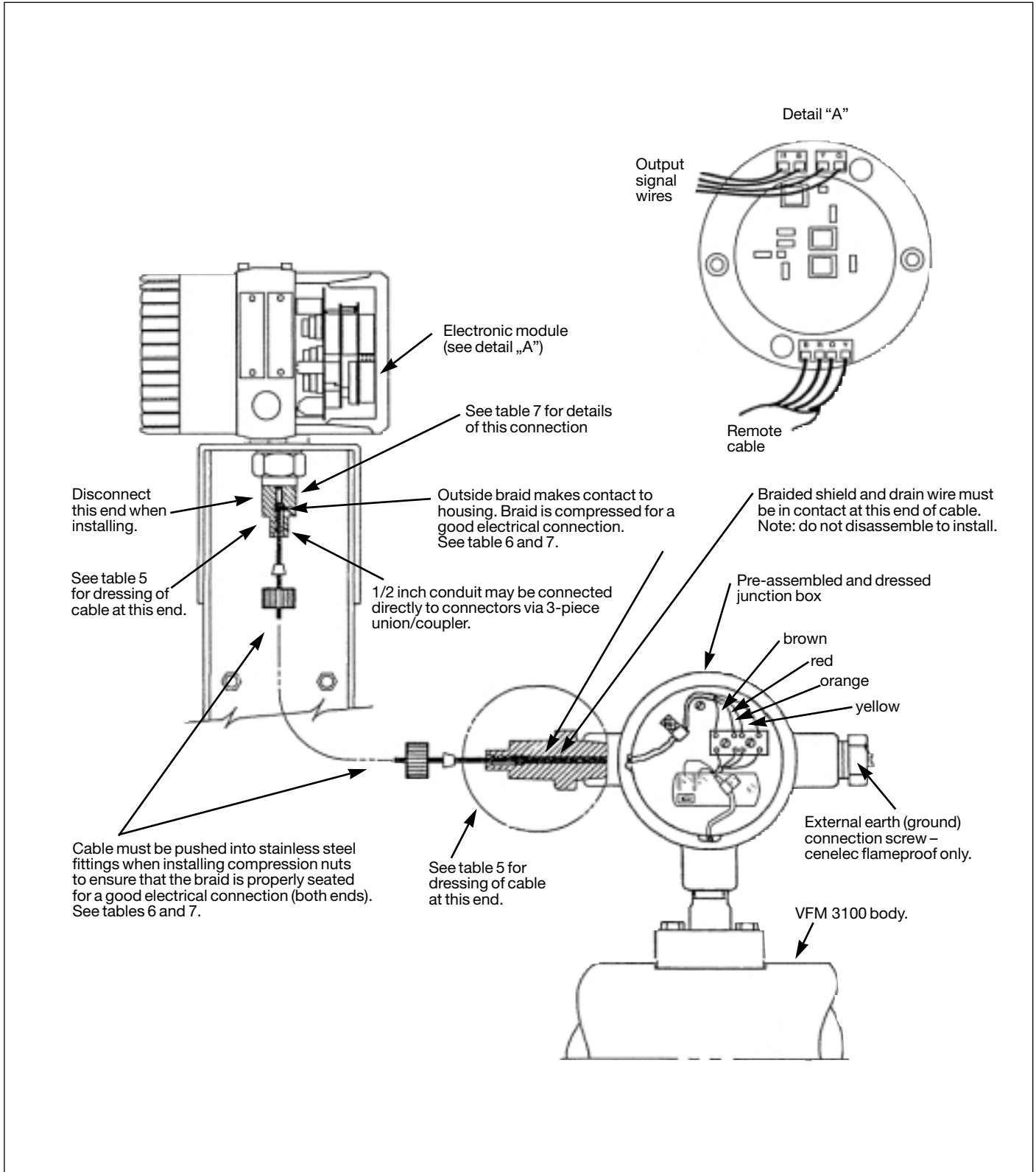

Figure 9. Overall View of Remote Mounted VFM 3100

Table 6. Connection of Remote Signal Cable

<h3>Electronics End (Electronic Housing End) Procedures</h3>	
<p>1. Take electronics end of prepared remote signal cable and align it as shown at right. Ready for assembly.</p>	 <p>Push cable assembly into connector</p> <p>Shrink tube or tape</p> <p>Prepared remote signal cable (electronics end) refer to table 3</p> <p>Rubber bushing</p> <p>Knurled nut</p> <p>Electronics end</p>
<p>2. As shown in the diagrams at right, push the prepared cable assembly into the remote connector. Push until the cable bottoms out (cannot be pushed in any further). Push rubber bushing into position and tighten the knurled nut onto the remote connector to create a good compression fit.</p>	 <p>2 twisted pairs</p> <p>Shrink tube or electrical tape</p> <p>Remote connector</p> <p>Compression fit of copper braid in contact with connector for shielding</p> <p>Rubber bushing</p> <p>Knurled nut</p> <p>Electronics end</p> <p>Remote signal cable</p>

Table 7. Connection of Remote Signal Cable (Electronics End)

<h3>VFM 3100 End (Junction Box End) Procedures</h3>	
<p>1. Take VFM 3100 end of prepared remote signal cable and align it as shown at right. Ready for assembly.</p>	 <p>Push cable assembly into connector</p> <p>2 twisted pairs</p> <p>Prepared remote signal cable (VFM 3100 end) refer to table 2</p> <p>Drain wire folded back</p> <p>Rubber bushing</p> <p>Knurled nut</p> <p>VFM 3100 end</p>
<p>2. As shown in the diagrams at right, making sure that the drain wire is folded back against the copper braid, push the cable assembly into the remote connector. Push until the cable bottoms out (cannot be pushed in any further). Push rubber bushing into position and tighten the knurled nut onto the remote connector to create a good compression fit.</p>	 <p>Shrink tube or electrical tape</p> <p>Rubber bushing</p> <p>2 twisted pairs</p> <p>VFM 3100 end</p> <p>Remote signal cable</p> <p>Knurled nut</p> <p>Junction box connector</p> <p>Compression fit of drain wire and copper braid in contact with connector for shielding</p>

Installation with Conduit:

- The junction box is pre-wired. A conduit box or conduit may be mounted directly to the 1/2 NPT connection at the remote housing. A box or a standard 3-piece union/coupler may be mounted directly over the knurled nut. Do not disassemble pre-wired connection at junction box.
- Run remote cable to the remote electronic module housing via conduit. If required, prepare cable as shown in Table 5. Feed it into the housing following Steps in the procedure for "Interconnection Wiring for Remote Electronics" on page 13 and Table 6 on page 17.
- Mount conduit box or conduit to the 1/2 NPT connector directly or via a 3 piece union/coupler, if necessary. Make connection to the 1/2 NPT connector after the knurled nut has been tightened to provide a compression fit for the cable. Refer to Table 6 on page 17.
- At this point, follow Steps in the procedure for "Installation Without Conduit" on page 13.

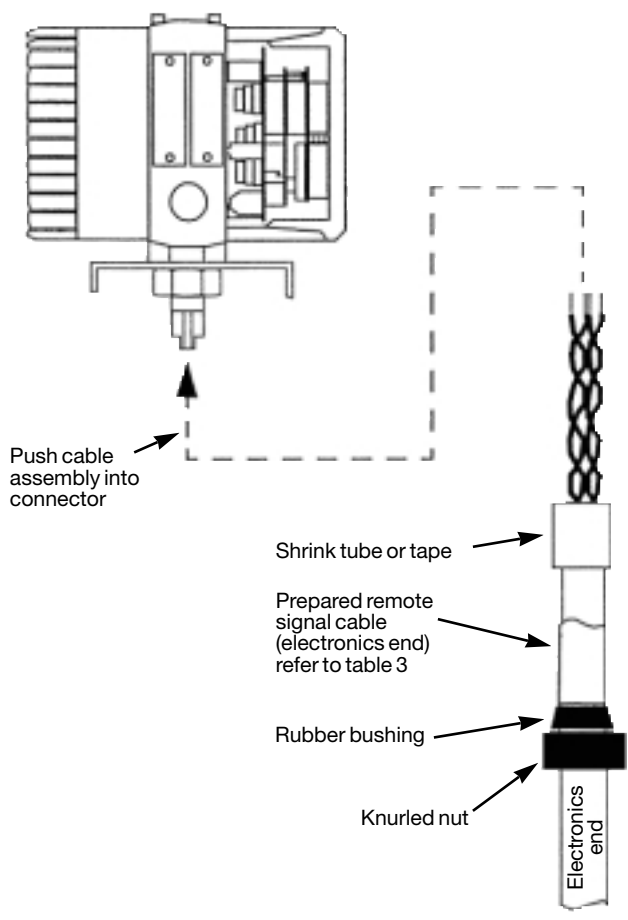
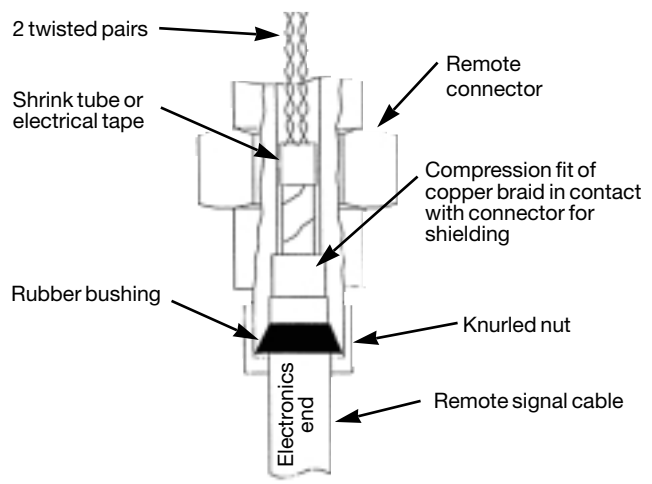
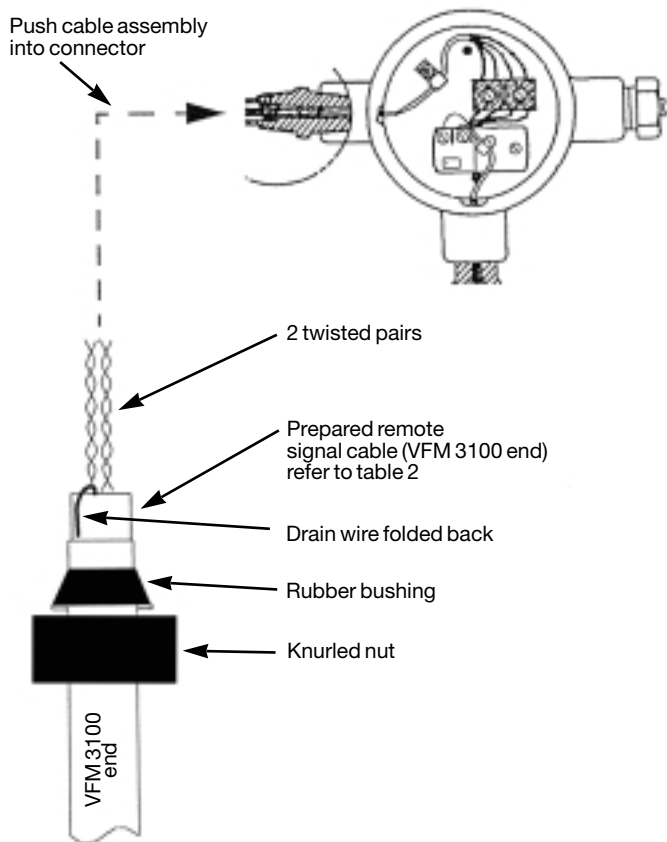
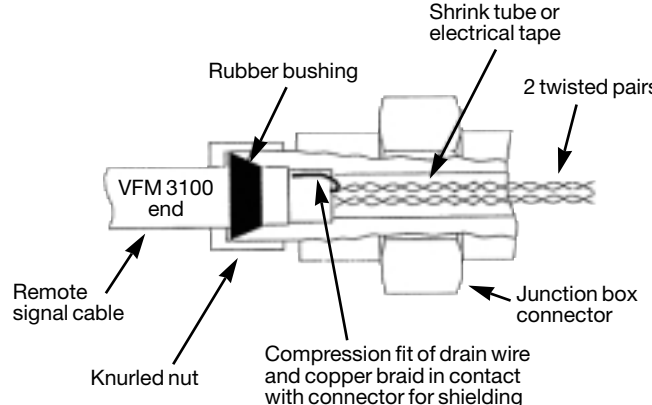
CENELEC Flameproof Version:

- The junction box side of the remote configuration is pre-wired. Add flameproof cable gland or E-Y fitting and conduit directly to the special Foxboro adapter or via an approved CSA/UL 3-piece union/coupler, if necessary. For this reason, the second conduit plug is fitted with a grounding screw (see Figure 9).

NOTE: CENELEC certification requires that an infallible physical earth (PE) connection be made to the junction box.

- Run the remote cable to the remote electronic module housing via cable trays or conduit.
- Place knurled nut and rubber bushing over the cable as shown in Table 5 on page 15.
- Prepare the remote cable as shown in Table 5.
- Remove the locked electronic module component cover from remote electronic module housing. Unscrew captive mounting screws and remove the electronic module without disconnecting loop power wiring.
- Feed prepared remote cable into the electronics housing through connector at bottom of housing. Push it in until the outer jacket bottoms out inside the connector. See Table 6.
- Ensure that the cable is pushed in all the way and then push the rubber bushing into position. Tighten the knurled nut to create a compression fit. See Table 6.
- Inside the remote electronics housing, connect the four wires of the remote cable to the 4-position terminal block on the rear of the electronic module.
Follow the color-coded label. See Figure 9 on Page 16.
- Ensure that the excess remote cable and loop power wires are tucked in under the electronics module. Without pinching, place the module back into the housing and tighten the mounting screws.
- Replace the housing cover tightly to prevent moisture and other contaminants from entering and then lock it in place.

1.3. Field Termination

The following section addresses Wiring, conduit, and Earth (Ground) Connection details.

1.3.1. Conduit Connections

NOTE: The wiring installation shall be in accordance with the local or national regulations applicable to the specific site and classification of the area.

The electronics housing has an electronic module compartment and a field terminal compartment. It also provides 1/2 NPT conduit openings for access from either side of the VFM 3100 and for ease in wiring to the field terminals. See Figure 10.

NOTE: One conduit opening contains a threaded plug. Do not discard this plug.

Remove the field terminal compartment cover (shown in Figure 10) to make electrical connections. Keep the electronic module compartment cover closed to ensure protection for the electronic module and to prevent moisture and atmospheric contaminants from entering the compartment.

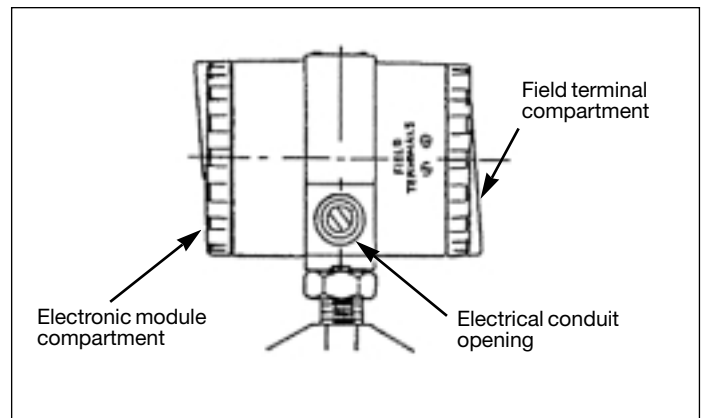

Figure 10. Electronics Housing

There are three wiring combinations that depend on how the VFM 3100 is to be used.

- 2-Wire Hook-up
4 to 20 mA and HART (1200 baud)
- 3-Wire Hook-up
4 to 20 mA, HART (1200 baud) and Scaled Pulse
- 4-Wire Hook-up
4 to 20 mA, HART (1200 baud) and Scaled Pulse

Two-Wire Hook-up

A dc power supply must be used with each transmitter and receiver wiring loop to supply power for the mA signal. The dc power supply may be either a separate signal unit, a multiple unit supplying power to several transmitters, or built into the receiver. Connect the supply and receiver loop wiring (0.50 mm² or 20 AWG typical) to the terminals in the field-terminal compartment of the transmitter, as shown in Figure 11.

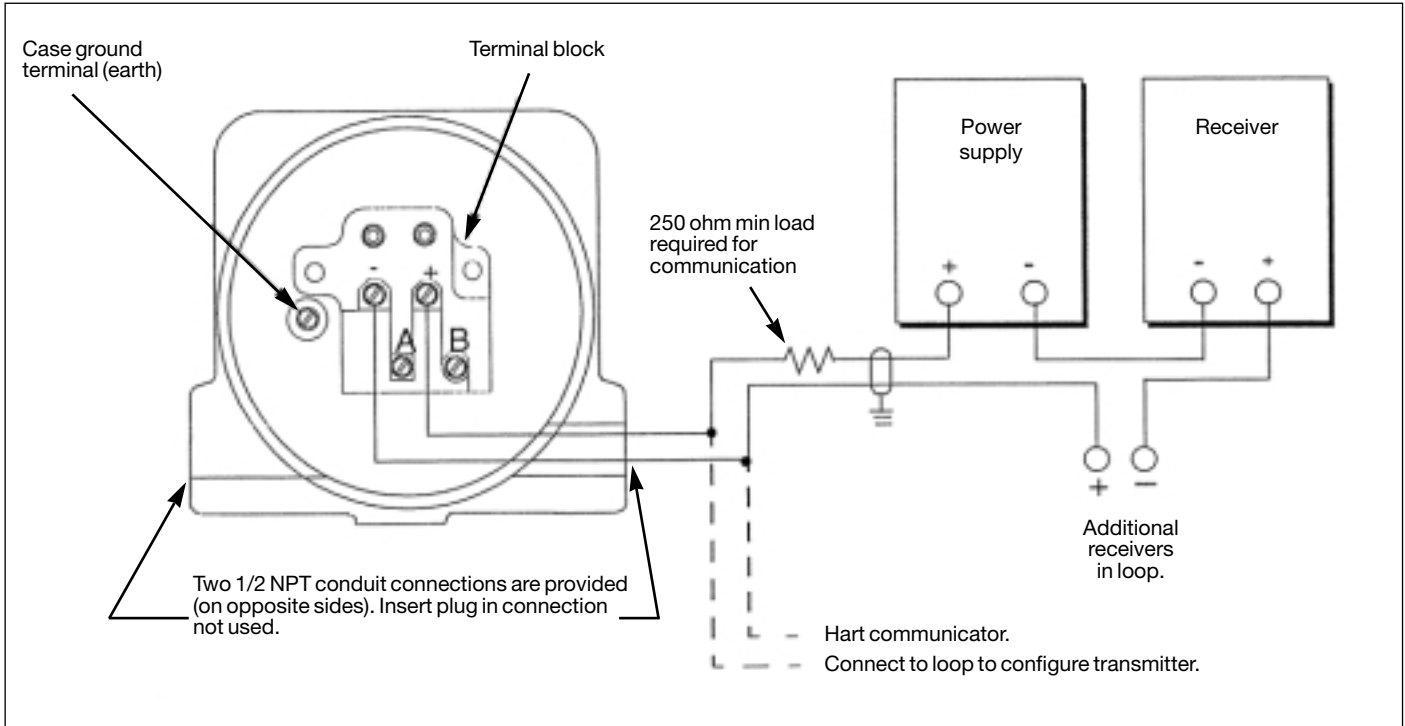

Figure 11. Installation Wiring -4-20 mA Output (Two-wire)

Twisted pair wiring should be used to prevent electrical noise from interfering with the dc current output signal. In some instances, shielded cable may be necessary. Earthing (grounding) of the shield should be installed at one point only (at the power supply). Do not earth (ground) the shield at the transmitter. Transmitter connection polarities are indicated on the terminal block. If the loop is to contain additional instruments, install them between the negative terminal of the transmitter and the positive terminal of the receiver, as shown in Figure 11.

Power Supply and External Load

The required loop power supply voltage is based on the total loop resistance. To determine the total loop resistance, add the series resistance of each component in the loop (do not include transmitter). The required power supply voltage can be determined from Figure 12.

The transmitter will function with an output load less than 250 ohms, provided that a configurator is not connected to it. Connecting a configurator to a loop with less than 250 ohms may cause communication problems.

As an example, for a transmitter with a loop resistance of 500 ohms, referring to Figure 12, the minimum power supply voltage is 22 V dc, while the maximum power supply voltage is 42 V dc. Conversely, given a power supply voltage of 24 V dc, the allowable loop resistance is from 200 to 565 ohms.

NOTES:

- The power supply must be capable of supplying 22 mA.
- Power supply ripple must not allow the instantaneous voltage to drop below 12.5 V dc at the transmitter.
- The recommended minimum load is 250 ohms.

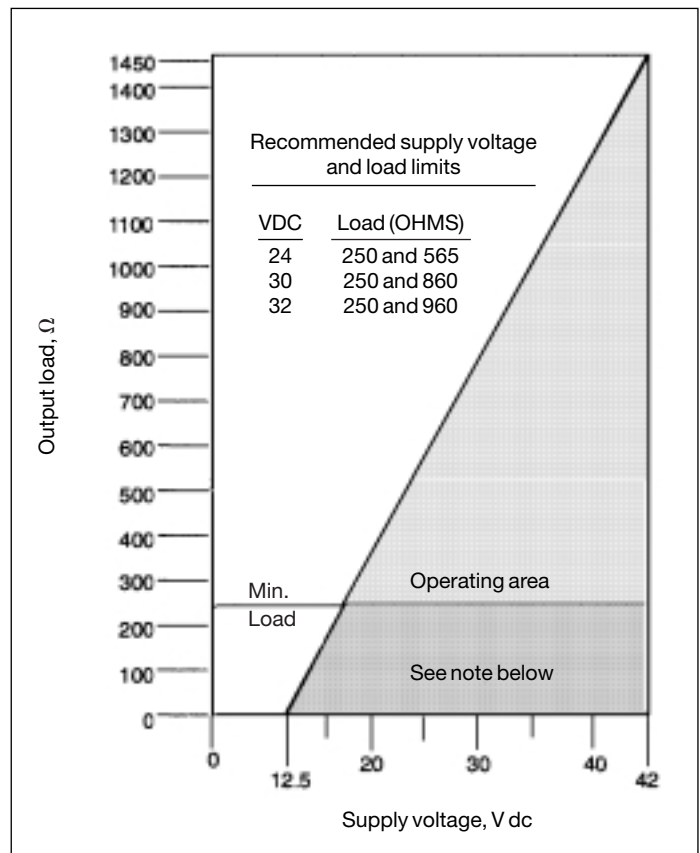

Figure 12. Load Requirements

Three-Wire Hook-up (See Figure 13)

Scaled Pulse Output

This wiring is primarily used to retrofit VFM3100 transmitters that were wired as pulse only transmitters for totalization. This wiring is typically for retrofitting existing installations. Configure the transmitter for pulse output. Refer to the section on changing the configuration beginning on page 23.

For new installations, a four-wire hook-up is recommended for scaled pulse operation to improve communication integrity.

A dc power supply must be used with each transmitter and receiver wiring loop to supply power for the transmitter. The dc power supply may be either a separate signal unit, a multiple unit supplying power to several transmitters, or built into the receiver. Connect the supply and receiver loop wiring for pulse out (0.50 mm 2 or 20 AWG typical) to the terminals in the field-terminal compartment of the transmitter, as shown in Figure 13. To use this type of 3-wire hookup, the blue and green terminals on the back of the module must be shorted.

A resistor is required to produce a voltage drop for proper operation of the counter. A 680 ... 2 W resistor is recommended for most coun-

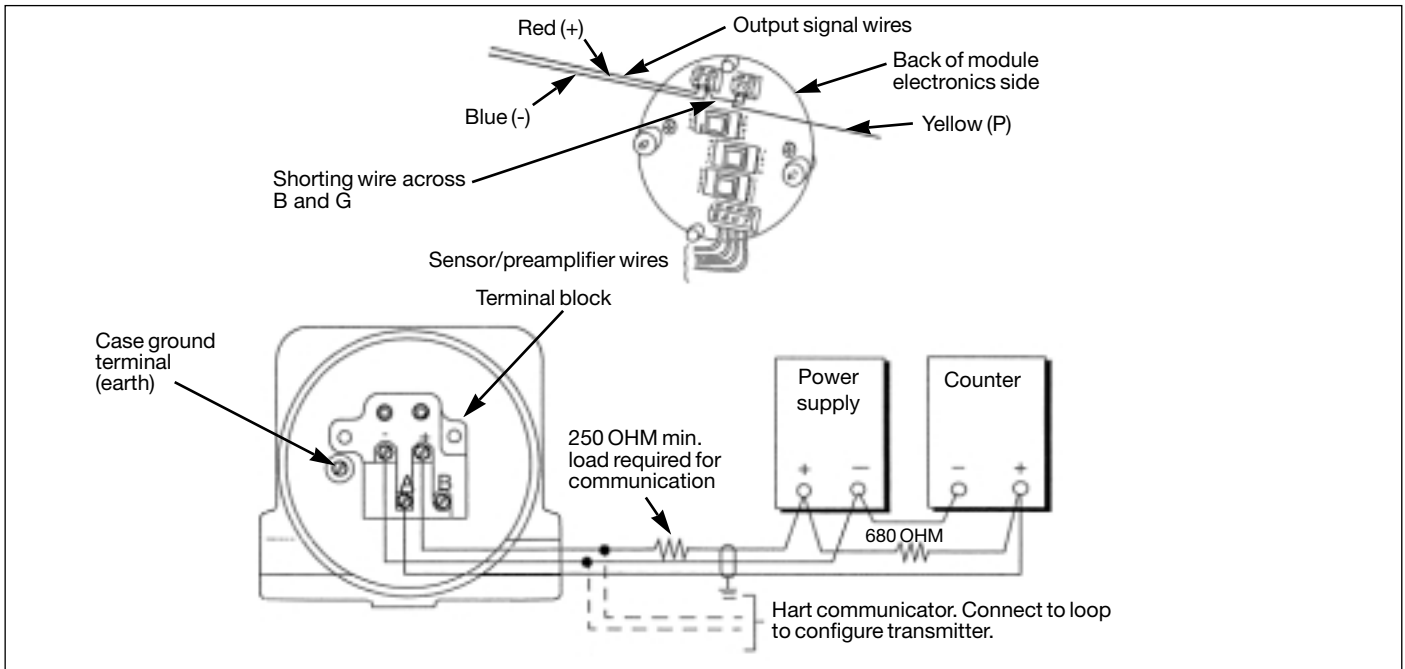

Figure 13. Installation Wiring – Pulse Output (Three-wire)

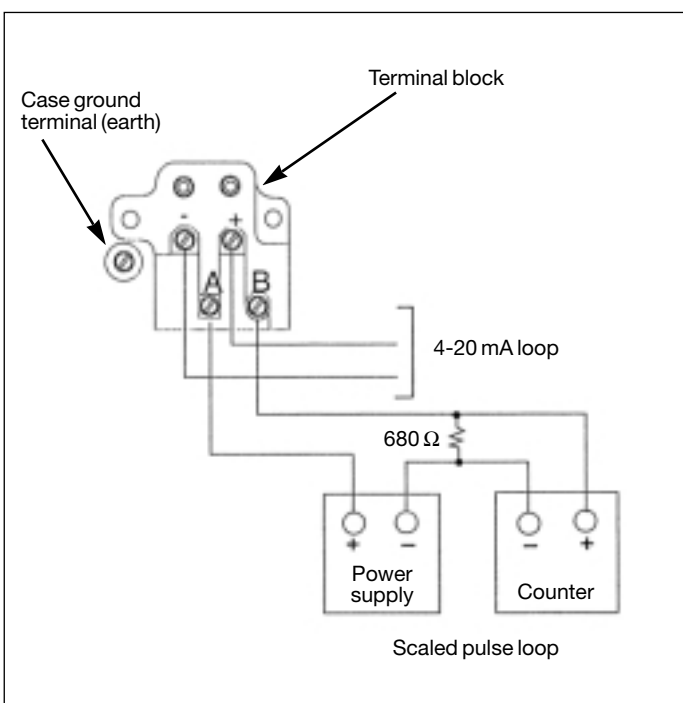

Figure 14. Installation Wiring (Four-wire)

ters. The pulse signal can cause interference to signals in adjacent signal cables. In some instances, shielded cable may be necessary. Earth grounding of the shield should be at one point only (at the power supply). Do not ground the shield at the transmitter. Transmitter connection polarities are indicated on the terminal block.

Power Supply and Load

The power supply voltage must be between 12.5 and 42 V dc. The pulse "OFF" state current is a maximum of 0.42 mA at 42 V dc. In the "ON" state, the pulse output is short circuit protected for 250 mA.

Four-Wire Hook-up

Two separate loops are required when using the scaled pulse output in the four-wire hook-up arrangement. Each loop requires its own power supply. Refer to Figure 14. Select the resistor so that the current through the contact closure does not exceed 250 mA.

Wiring may be run in conduit or in wireways. The wiring must meet all applicable local standards such as hazardous location requirements and electrical wiring codes. Signal wires should not be run in the same conduit as power wires. Shielded twisted pair wiring is recommended.

2. Operating the VFM 3100

2.1 Introduction

Communication with the VFM 3100 is carried out using the HART Model 275 Communicator or the optional Local Digital Display/Configurator. General instructions for using the HART Configurator can be found in MAN 4250, HART Communicator Product Manual.

Vortex-specific instructions for using the HART configurator will be found in chapter 8 of this document. Complete instructions for using the Local Configurator will be found in chapter 9.

Note: For proper communication with VFM 3100, the HART configurator must contain the DD for the KROHNE VFM 3100. This DD is available from KROHNE, or any other authorized HART Foundation source.

Table 8. Configuration Database

<ul style="list-style-type: none"> Flowtube Parameters Model Code Meter Body Serial Number Reference K-Factor 	<ul style="list-style-type: none"> Process Fluid Parameters Fluid Type Process Temperature Process Density Base Density Process Viscosity
<ul style="list-style-type: none"> Identification Parameters Tag Descriptor Date Message Polling Address 	<ul style="list-style-type: none"> Application Parameters Mating Pipe Piping Configuration Upstream Distance Custom K-factor Bias Upper Range Value
<ul style="list-style-type: none"> Transmitter Options Flow Units Total Units Noise Rejection Signal Conditioning Low Flow Correction Low Flow Cut-In 	<ul style="list-style-type: none"> Output Options Damping Value Pulse Output AO/PO Alarm Type

2.2 Passwords

The transmitter itself has no password. Rather, security measures, i.e., the ability to access functions such as calibration, configuration, and testing, are associated with the configurators used to communicate with the transmitter. The HART Communicator has no security measure other than access to the device itself. The Local Digital Display/Configurator requires a password that is user definable. See chapter 9.

2.3 Configuration Database

In order to function, the transmitter requires specific embedded information, termed the “configuration database”. The parameters in this database are listed in Table 8, and defined in chapter 9.

Each VFM 3100 is shipped from the factory with an operating configuration database; however, the VFM 3100 will not provide an accurate measurement if the configuration does not fit the application.

Be sure to check the configuration of each VFM 3100 prior to start-up!

In all cases, the factory configuration includes the VFM 3100 Model Code, Meter Body Serial Number, and Reference K-Factor. It also includes the User Information in Table 9, if supplied with the purchase order.

Table 9. User Information

<ul style="list-style-type: none"> Tag Fluid Type Flow Units Total Units Process Temperature (value and units) Process Density (value and units) Base Density (if applicable; value) Process Viscosity (if applicable; value and units) Upper Range Value

If the User Information in Table 9 is not supplied with the purchase order, the transmitter is shipped with the following default set:

Item	Metric	U.S.
Tag	blank	blank
Flow Units	l/min	USgpm
Total Units	l	USgal
Fluid Type	Liquid (water)	Liquid (water)
Process Temperature	20°C	70°F
Process Density	998,2 kg/m ³	62.301 lb/ft ³
Base Density	999.2 kg/m ³	62.374 lb/ft ³
Flowing Viscosity	1.002 cP	0.9753 cP
Upper Range Value	Upper Range Limit for VFM 3100 Size	Upper Range Limit for VFM 3100 Size

The units of this default configuration database, i.e., Metric or U.S., are established by the units of the Reference K-Factor.

NOTE: These defaults are not recommended for general operation. If no other process information is available, entering "Liquid", "Gas", or "Steam" as fluid type will establish default data bases as listed on page 24.

Be sure to read the explanation of each parameter in "Configuration Database" on page 22 prior to changing the configuration.

The remaining items in the database will have the following default values:

Descriptor	blank
Date	blank
Message	blank
Polling Address	0
Noise Rejection	On
Signal Conditioning	On
Low Flow Correction*	Off
Low Flow Cut-In	(3rd level above minimum)
Mating Pipe	Schedule 40
Piping Configuration	Straight
Upstream Distance	30 Pipe Diameters
Custom K-factor Bias	0.0%
Damping Value	2.0 sec
Pulse Output	Off
AO/PO Alarm Type	Upscale

* If the process density and viscosity are provided, the Low Flow Correction will be set to On.

NOTE: These default values should be changed to match the specific application. Before making any changes, be sure to read the explanation of each parameter in "Configuration Database" on page 22.

2.4. Changing the Configuration (Configuration Menu)

Using the HART Communicator or the Local Digital Display/Configurator, any parameter in the configuration database can be changed to fit the application by entering the Device Setup or Configuration Menu. The specific details for doing this depend on the configurator, and are described in chapter 7 or 8. Some general information is presented below.

2.4.1. Identification Parameters

Tag	Default tag may be changed as desired.
Descriptor	Default descriptor may be changed as desired.
Date	Default date may be changed as desired.
Message	Default message may be changed as desired.
Polling Address	Default address may be changed as desired. (See note below).

NOTE: The HART protocol allows the connection of up to 15 HART devices on a single twisted pair of wires, or over leased telephone lines, a concept known as 'multidropping'. In a multidrop installation, each transmitter is identified by a unique address (1-15) referred to as the polling address. In the multidrop mode, i.e., if the polling address is non-zero, the analog output is set to a fixed value of 4 mA. For a non-multidrop installation, i.e., a single transmitter loop, the polling address of the transmitter should be left in its default value (0) if the analog output is intended to indicate flow (4-20 mA). In a multidrop installation the polling address of each transmitter must be set to a unique integral value of 1 through 15. This can be done before or after installation with the local configurator. If using the HART Communicator, the polling address of each transmitter must be set individually prior to installing in a multidrop environment.

2.4.2. Transmitter Option

Flow Units	Default units may be changed as desired.
Total Units	Default units may be changed as desired.
Noise Rejection	Keep default value On.
Signal Conditioning	Keep default value On.
Low Flow Correction	Should be changed to On if the low end of the operating range is below a Reynolds Number of 20,000. NOTE: If On is selected, actual values of the process density and process viscosity must be entered into the database!
Low Flow Cut-In	The default value for the Low Flow Cut-In is the third level above the minimum. After installing the VFM 3100, this level can be changed such that under no-flow conditions the flow output is zero. (See the following section "Adjusting the VFM 3100" on page 26.)

NOTE: If the User Information is not supplied with the purchase order, the following default data for a LIQUID will reside in the database.

Parameter	Metric	U.S.
Tag	blank	blank
Flow Units	l/min	USgpm
Total Units	l	USgal
Fluid Type	Liquid (water)	Liquid (water)
Process Temperature	20 °C	70 °F
Process Density	998,2 kg/m ³	62.301 lb/ft ³
Base Density	999.2 kg/m ³	62.374 lb/ft ³
Process Viscosity	1.002 cP	0.9753 cP
Upper Range Value	Upper Range Limit for VFM 3100 Size	Upper Range Limit for VFM 3100 Size

If the process fluid is not LIQUID, changing the fluid type to GAS or STEAM will automatically bring up the appropriate default set shown below.

Parameter	Metric	U.S.
Tag	blank	blank
Flow Units	Nm ³ /hr	SCF/hr
Total Units	Nm ³	SCF
Fluid Type	Gas (Air)	Gas (Air)
Process Temperature	20 °C	70 °F
Process Density	9.546 kg/m ³	0.5858 lb/ft ³
Base Density	1.293 kg/m ³	0.07634 lb/ft ³
Process Viscosity	0.0185 cP	0.0186 cP
Upper Range Value	Upper Range Limit for VFM 3100 Size	Upper Range Limit for VFM 3100 Size

Parameter	Metric	U.S.
Tag	blank	blank
Flow Units	kg/hr	lb/hr
Total Units	kg/hr	lb/hr
Fluid Type	Steam (saturated)	Steam (saturated)
Process Temperature	175 °C	350 °F
Process Density	4.618 kg/m ³	0.2992 lb/ft ³
Base Density (N/A)	0.5977 kg/m ³	0.03730 lb/ft ³
Process Viscosity	0.0149cP	0.0150 cP
Upper Range Value	Upper Range Limit for VFM 3100 Size	Upper Range Limit for VFM 3100 Size

As mentioned previously, the units of the default configuration database, i.e., US or Metric, are established by the units of the Reference K-Factor.

These defaults are not recommended for general operation and should be used only when no other information is known about the process other than the fluid type. Be sure to read the explanation of each parameter in chapter 9. Configuration Database, prior to changing the configuration.

2.4.3. Process Fluid Parameters

Fluid Type	Selecting the fluid type establishes an appropriate default database which can be modified to fit the application.
Process Temperature units must be entered.	For accurate flow measurement, the actual value in the selected
Process Density	For optimal performance and accurate mass flow measurement, the actual value in the selected units must be entered.
Base Density	For accurate standard volume flow measurement, the proper value must be entered in the same units as Process Density.
Process Viscosity	For accurate flow measurement at low flow, the actual value in the selected units must be entered. It is essential that the process viscosity be entered if the Low Flow Correction option is On.

2.4.4. Application Parameters

Mating Pipe	Select upstream mating pipe schedule.
Piping Configuration	Select upstream piping configuration.
Upstream Distance	Enter distance to first upstream flow disturbance in pipe diameters.

NOTE: The VFM 3100 uses the above three parameters to correct internally for the effects of upstream piping and disturbances on the Flowing K-Factor. Other known bias corrections can be entered under Custom K-Factor Bias.

Custom K-factor Bias	To compensate for additional known biases in the flow measurement system, enter the value, with sign, in percent.
Upper Range Value	Enter desired maximum flowrate.

2.4.5 Output Options

Damping Value	Enter desired time in seconds.
Pulse Output	Select desired output.
AO/PO Alarm Type	Select desired fail condition. Applies only to 4 to 20 mA and Pulse outputs.

2.5. Preconfiguring the VFM 3100

With the HART Communicator, the database can be generated offline and then downloaded to the transmitter. The procedure for building the database consists of entering the appropriate information as it is requested.

NOTE: The password for the local display configurator cannot be configured from the HART Communicator.

2.6. Displaying the Configuration Database

HART Communicator (Review Menu).

The parameters in the configuration database can be viewed without entering the Setup Menu. This is done via the Review Menu.

Local Configurator (Display Menu).

The parameters in the configuration database can be viewed without entering the Configuration Menu. This is done via the Display Menu.

2.7. Adjusting the VFM 3100

The following four adjustments can be made to the VFM 3100:

mA Calibration (D/A Trim)
Total Reset
Low Flow Cut-In
Upper Range Value

These appear in various places in the structures (refer to chapter 7 and 8).

2.7.1. mA Calibration (D/A Trim)

This function allows the 4 to 20 mA output of the transmitter to be calibrated or matched to the calibration of the receiving device.

NOTE: The transmitter has been accurately calibrated at the factory. Recalibration of the output is normally not required unless it is being adjusted to match the calibration of the receiving device

2.7.2. Total Reset

This function allows the flow total to be reset to zero

2.7.3. Low Flow Cut-In

The low flow cut-in parameter allows the user to set the level above which the VFM 3100 begins to measure flow, i.e., the lower range limit of the VFM 3100. This process can be carried out automatically if the flow is turned off. Otherwise, manual selection from the following pick-list of eight levels can be made:

Auto, (LO), (L1), (L2), (L3), (L4), (L5), (L6), (L7)

For convenience, these levels are displayed as estimated flow rates in the selected flow units. The value of these flow rates depend on the specific application parameters.

With the HART configurator the current value is displayed, and you can elect to decrease or increase the level by one. If the level does not change when this is done, the minimum or maximum level has been reached, respectively. In the case of the local configurator you can select the desired level from the displayed pick-list.

If Automatic mode is selected, the VFM 3100 chooses the lowest level at which no signal is detected over a 20 second time interval. You may wish to increase or decrease this setting. For instance, noise signals could be occurring at an interval greater than 20 seconds and possibly not be detected during the automatic selection process. Repeating the auto-selection process helps to avoid this possibility.

2.7.4. Upper Range Value

This parameter sets the desired maximum flowrate of the VFM 3100.

2.8. Reading the Measurements

The Process Variable Menu (HART) or the Measurement Menu (Local) provides periodically updated values of the flow rate, vortex frequency (frequency in), scaled pulse frequency (frequency out), and flow total. The flow rate and total are presented in units of volume or mass as configured, the frequencies in Hz. Due to the limited size of the local display only one parameter is displayed at a time. It is possible to configure the device to display in succession two, three, or four of the variables, as selected from a pick-list.

2.9. Testing the VFM 3100 and Loop (Test Menu)

Entering the Diag/Service Menu for the HART Communicator or Test Menu for the Local Configurator allows the following two test procedures to be activated:

- Self-Test
- Loop Test or Loop Calibration

2.9.1. Self-Test

This selection checks transmitter operation by injecting, near the front end of the electronics, an internally generated periodic signal of known frequency. The frequency of this signal is in turn measured and checked against the injected signal.

2.9.2. Loop Test or Loop Calibration

This selection allows the transmitter to be used as a signal source to check and/or calibrate other instruments in the control loop, such as indicators, controllers, and recorders. The mA, scaled pulse, and digital output signals can be adjusted to any value within the range limits of the VFM 3100.

2.10. Electronic Module Replacement

If an Electronic Module is shipped as a replacement, the correct flowtube parameters will not reside in its configuration database. For proper operation of the VFM 3100, the correct values must be entered. If the configuration database from the original VFM 3100 was saved to a file, this file, containing the correct flowtube parameters, can be downloaded to the new transmitter. If this is not the case, they must be entered manually from the VFM 3100 tag.

In the latter case, enter the following data first when configuring the VFM 3100!

- Model Code: Enter alphanumeric Model Code from VFM 3100 body tag (first 14 characters).

NOTE: If a Model Code beginning with the letter 'E' is entered via the local configurator, a prompt screen will be displayed requesting that the VFM 3100 configuration be selected from the following list:

- Single Measurement
- Dual Measurement
- Single Measurement with Isolation Valve
- Dual Measurement with Isolation Valve

This capability is NOT available with the HART configurator; hence, the local configurator must be used to enter the flowtube parameters if the Model Code begins with the letter 'E'.

If the Model Code does not begin with an 'E', the above information is read directly from the Model Code.

- VFM 3100 Body Serial Number: Enter alphanumeric Serial Number from VFM 3100 tag.

NOTE: Although the VFM 3100 will operate properly without this information, it is convenient to enter it at this point.

- Reference K-Factor: Enter numeric value from VFM 3100 body tag

NOTE: It is not necessary to enter the units of the Reference K-Factor. The units, i.e., US (pulses/ft³) or Metric (pulses/liter), are determined internally by the VFM 3100, based on the nominal size of the VFM 3100 (contained in the Model Code) and the entered numeric value of the Reference K-Factor.

3. Troubleshooting

3.1. General Troubleshooting

To maximize the usefulness of this chapter, read this General Troubleshooting section first. Then, follow the applicable procedural steps in the order presented. Persons performing troubleshooting procedures should be suitably trained and qualified for those procedures.

NOTE: If applicable, remove transmitter under test from multidrop environment.

3.1.1. VFM 3100 Has Incorrect Output

Check the configuration. Be sure the VFM 3100 has been configured correctly.

Incorrect 4 to 20 mA Output

- Be sure the upper range value is correct.
- Check that the correct flow units are specified.
- Check that the VFM 3100 is not in the multidrop mode by verifying that the polling address is zero. In the multidrop mode the mA output is fixed at a constant 4 mA.
- Check that the VFM 3100 is not in one of the application default modes.
 - a. For liquid the default mode is water. For many situations this may be adequate.
 - b. For steam the default is 125 psig saturated steam. There may be significant error at other pressures.
 - c. For gas the default mode is 100 psig air. Other gases and other conditions require the correct configuration for density and base density.

Incorrect Digital Output

- Check that the correct flow units are specified.
- For custom flow units check that the conversion factor is correct. Refer to “Determining Special Measuring Units” on page 43 to calculate the conversion factor.
- Check to be sure that the VFM 3100 is not in one of the application default modes.

Incorrect Pulse Output

- Verify that correct flow units are used. Check the pulse resolution factor.
- The scaled pulse output can only be used with a receiver that does not calculate period, such as a counter.

3.1.2. VFM 3100 Output Indicates Flow When There Is No Flow

In some installations, the VFM 3100 can indicate flow when the line is shut down. This could be the effect of a leaking valve, sloshing fluid, or noise sources such as pump-induced pipe vibration. To eliminate these false signals, try the following:

NOTE: Remote mounted VFM 3100 with standard temperature range sensors may have noisy signals if the slide switch on the preamplifier is in EXT position. Be sure the switch is in the correct position to match the sensor.

- Be sure there is no flow.
- Be sure the noise rejection feature is set to ON.
- If damping is ON and set to greater than zero, the noise spikes that exceed the low flow cut-in will appear as decaying signals less than the low flow cut-in.
- Adjust the low flow cut-in level to produce zero output. This level can be automatically set or manually adjusted via the configurator.
- Check that transmitter and power supply are properly earthed (grounded). This is particularly important for remote installations. Refer to “Field Termination” on page 19 and “Interconnection Wiring for Remote Electronics” on page 13.
- For remote VFM 3100, verify that signal cable has been properly terminated.

3.1.3. VFM 3100 Output Indicates Higher Flow Rate with Decreasing Flow

- Be sure the noise rejection feature is set to On.
- Adjust the low flow cut-in level to produce zero output. This can be done with automatic or manual adjustment.

3.1.4. Fluctuating Output

- Verify that the signal conditioning feature is On.
- Fluctuations may be a true picture of the actual flow.
- A small offset of 1 to 2% with rapid fluctuations may be caused by gaskets protruding into the flow stream.

3.2. No Output Troubleshooting

NOTE: VFM 3100 with extended temperature range sensors will have reduced output if the slide switch on the preamplifier is in STD position. Be sure the switch is in the correct position to match the sensor.

- Be sure there is flow.
- Check the power supply. The voltage across the + and - terminals must be between 12.5 and 42 volts dc.
 - a. If voltage is zero, check for blown fuse in power supply.
 - b. If voltage is low, but not zero, the VFM 3100 may be loading the power supply. Remove the field terminal cover. Disconnect the + and - leads and measure the voltage from the power supply. If the voltage returns to normal, the circuit is good to this point. Reconnect power to the + and - terminals.
 - c. Remove the electronic module compartment cover. Loosen the mounting screws and remove the electronic module from the housing. Measure the following voltages on the B-R-O-Y terminal block. They should be:

Red to Yellow:	+2.6 +0.2 Volts dc
Orange to Yellow:	+2.6 +0.2 Volts dc

If the voltages are not within specifications, disconnect the red and orange wires to the preamp and measure the voltages again. If they do not return to ± 2.6 , replace the electronic module. (See “Electronic Module Replacement” on page 33.) If they do return to normal, replace the preamplifier.

- d. If the voltage remains low, the housing/field terminal wiring is bad. Replace the housing or return the VFM 3100 to Krohne for repair.
- Checking the 4-20 mA output loop.
 - a. The 4-20 mA loop may be monitored via the test jacks in the field output terminal board. The signal produced will be 0.1-0.5 volts, corresponding to 4-20 mA. Be sure the VFM 3100 is not configured for the multidrop mode by verifying that the polling address is zero. The output is fixed at a constant 4 mA in the multidrop mode.
 - b. Increase the flow to be sure that the lack of response is not caused by operation below the Low Flow Cut-in.
 - c. If there is no response to increasing flow, perform one of the following tests:
 - “Module Test Procedure”
 - “Preamplifier Test Procedure”
 - “Sensor Test Procedure” on page 29.

3.3. Module Test Procedure

The module may be tested for input frequency with a frequency generator. Connect the frequency generator to the outside terminals of the four-position terminal block. Connect the positive to the brown terminal and the negative to the yellow terminal. Be sure that loop power is connected. Increase the frequency until a flow rate is read. Do not exceed 3000 Hz. If no flow measurement is indicated, check that the module is configured correctly.

3.4. Preamplifier Test Procedure

3.4.1. Extended Temperature Range Sensor

Integral Mount Electronics

- Check slide switch mounted on the preamplifier to verify that the switch is in the EXT position.
- Check the electronic module to be sure it can provide the required power for the preamplifier. Loosen the mounting screws and remove the module from the housing. The 4-position terminal block on the back of the module provides power for the preamplifier assembly mounted near the sensor neck. The voltage with the preamp connected should read:

Red to Yellow:	$+2.6 \pm 0.2$ Volts dc
Orange to Yellow:	-2.6 ± 0.2 Volts dc

 If it does not, disconnect the preamp and measure again. If the voltage returns to normal, replace the preamplifier.
- If the voltage in Step 1 is satisfactory, use the module to power the preamplifier. Disconnect the sensor leads from the preamplifier.
- Connect a 32 pF $\pm 5\%$ 50 V dc NPO ceramic capacitor to the brown terminal of the sensor terminal block. Connect a sine wave generator across the input by connecting the positive lead to the capacitor and the negative lead to the yellow terminal. Use a 50-ohm terminator on the output of the signal generator. Use coaxial cable between the signal generator and the sensor input board.
- The preamplifier must be shielded to prevent 60 Hz interference. An aluminum foil tent grounded to the electronic module housing may be necessary.

- Set the generator for 500 Hz and 0.5 Volts peak to peak. The preamplifier output, brown to yellow leads, should be 500 Hz at 0.700 Volts (0.650 to 0.750 Vpp).
- Increase the frequency to 4200 Hz. The output should be between 0.444 and 0.540 Volts peak to peak.
- Decrease the frequency to 7.5 Hz. The output should also be between 0.444 and 0.540 Volts peak to peak.
- If the output is not within the correct values, replace the preamplifier.

Remote Mounted Electronics

The preamplifier is located in the junction box mounted on the flow tube. Execute test Steps 1 through 8 above.

3.4.2. Standard Temperature Range Sensor

Remote Mounted Electronics

- Check slide switch mounted on the preamplifier to verify that the switch is in the STD position.
- The preamp is located in the junction box. Check the electronic module to be sure it can provide the required power for the preamplifier. Loosen the mounting screws and remove the electronic module from the housing. The 4-position terminal block on the back of the electronic module provides power for the preamplifier assembly mounted near the sensor neck. The voltage with the preamp connected should read:

Red to Yellow:	$+2.6 \pm 0.2$ Volts
Orange to Yellow:	-2.6 ± 0.2 Volts

 If it does not, disconnect the preamp and measure again. If the voltage returns to normal, replace the preamplifier.
- If the voltage in Step 1 is satisfactory, use the electronic module to power the preamplifier. Connect the red, yellow, and orange leads to the electronic module and disconnect the brown lead. Disconnect the brown and yellow sensor leads.
- Connect a 3300 pF $\pm 5\%$ 50 V dc NPO ceramic capacitor to the brown terminal of the sensor terminal block. Connect a sine wave generator across the input. Connect the positive lead to the other capacitor lead and the negative lead to the yellow terminal. Use a 50-ohm terminator on the output of the signal generator. Use coaxial cable between the signal generator and the sensor input board.
- The preamplifier must be shielded to prevent 60 Hz interference. An aluminum foil tent grounded to the electronic module housing may be necessary.
- Set the generator for 500 Hz and 0.5 Volts peak to peak. The preamplifier output, brown to yellow leads, should be 500 Hz at 0.475 Volts (0.425 to 0.525 Volts peak to peak).
- Increase the frequency to 3200 Hz. The output should be between 0.275 and 0.375 Volts peak to peak.
- Decrease the frequency to 0.1 Hz. The output should be between 0.375 and 0.475 Volts peak to peak.
- If the output is not within the correct values, replace the preamplifier.

For this test, the preamplifier should be mounted in the housing in order to achieve the best shielding. Do not attempt this test with the preamplifier on the bench. It is very difficult to shield it from 50 or 60 Hz interference from fluorescent lighting.

Note that separate power supplies may be used to provide power a place of the electronic module.

3.5. Sensor Test Procedure

3.5.1. Standard Temperature Range Sensor

- Remove electronic module from housing.
 - Disconnect the yellow and brown sensor leads from back of electronic module.
 - Connect sensor lead to an oscilloscope.
 - With fluid flow in the pipe, observe signal waveform on oscilloscope. Waveform should be similar to that shown in Figure 15.
- a. If waveform is similar to Figure 15, the sensor is good. If there is no output from the electronic module, the electronic module input stage has failed. The entire electronic module should be replaced.
 - b. If there is no sensor output signal, the sensor has failed and should be replaced. See “Sensor Replacement with Integral Electronic Module” on page 37 for details.

3.5.2. Extended Temperature Range Sensor

- Remove the electronic module from the housing. Remove the preamplifier from the housing. First, pry the ears of the metal shield away from the sides of the housing. Then lift out the shield assembly.
- Disconnect the brown and yellow sensor leads from the preamplifier input terminal strip.
- With flow in the pipe, use an oscilloscope to observe the sensor output. The scope probe impedance must be 10 megohms or greater. The waveform should be similar to that shown in Figure 15. When the preamplifier is not in the circuit, the minimum signal required for the sensor is about 2.5 mV.

For liquid flow, the minimum signal of 2.5 mV will require about 25 Hz. Be sure that flow is enough to produce 25 Hz.

For gas or steam flow, the minimum signal of 2.5 mV may require 100 Hz or more, depending on meter size.

If the waveform is similar to Figure 15, the sensor is functioning. If there is no output, replace the sensor.

NOTE: For all sensors, be sure the signal being read is not the local power line frequency, i.e., 50 or 60 Hz.

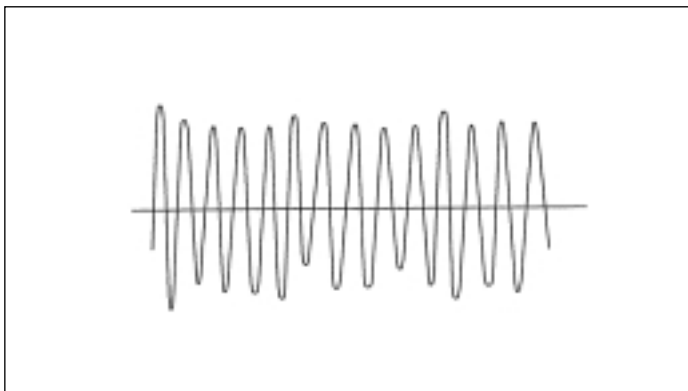

Figure 15. Normal VFM 3100 Frequency Waveform

4. Maintenance

4.1. Introduction

The operation of the VFM 3100 consists of three basic functions: generation and shedding of vortices in the fluid stream, sensing of vortices, and amplification, conditioning, and processing of the signal from the vortex sensor. Should a malfunction of the VFM 3100 be suspected, the cause can normally be isolated to one of these three functions.

Personnel involved in maintenance of VFM 3100 should be trained and qualified in the use of the equipment required and in the removal and replacement of the VFM 3100 in the piping. They should also be qualified for the routine maintenance of the VFM 3100 components.

4.1.1. Vortex Generation and Shedding

The process of vortex generation and shedding can be degraded or destroyed by disturbances in the upstream flow, the nature of the flowing fluid, or by damage to the vortex shedding element (rare). Such flow disturbances may be created by gaskets protruding into the flowing stream, by some form of partial blockage in the upstream piping, by the piping configuration, or by the existence of two-phase flow. Should the vortex shedding element become heavily caked, coated, or physically damaged to the extent that its basic shape or dimensions are changed, the vortex shedding process may be impaired. Also, the length of straight, unobstructed run of upstream piping is important (refer to “Piping Considerations” on page 9).

4.1.2. Vortex Sensing

There are two basic types of sensors employed by the VFM 3100 - Standard Temperature and Extended Temperature Range. The Standard Temperature Range sensor may be filled with Fluorolube Temperature Range sensor is an unfilled sensor for applications to 430 °C (800 °F).

The Standard Temperature Range sensor consists of a piezoelectric bimorph crystal that is sealed inside a liquid-filled capsule having two diaphragms on opposing sides. The vortex shedding process creates an alternating differential pressure across the capsule that is transmitted via the diaphragms and fill-fluid to the crystal.

The Extended Temperature Range sensor consists of two piezoelectric crystals sealed inside a capsule having two process diaphragms, on opposing sides, connected internally by a mechanical shuttle.

The vortex shedding process creates an alternating differential pressure across the capsule that is transmitted via the diaphragm-shuttle mechanism to the crystals.

The alternating force acting on the crystals causes them to develop a pulsed voltage with a frequency equal to the vortex shedding frequency. Damage to sealing diaphragms or other physical damage could cause the sensors to operate improperly.

4.1.3. Amplification, Conditioning and Processing

The vortex sensor signal is amplified, conditioned, and processed in the electronic module, which is located in the compartment of the electrical housing. In addition, the electronic module generates digital, 4 to 20 mA, and scaled pulse output signals. A simplified block diagram of the VFM 3100 is shown in Figure 16.

As shown, the electronic module accepts the raw sensor output directly from Standard Temperature Range sensors. When used with an Extended Temperature Range sensor, the raw sensor output must be buffered by a preamplifier before being passed to the electronic module. The preamplifier is also used with the standard temperature range sensor in remote installations. A switch on the preamplifier is used to match impedance to the sensor. In either case, the electronic module receives and processes the vortex signal and provides the various output signals.

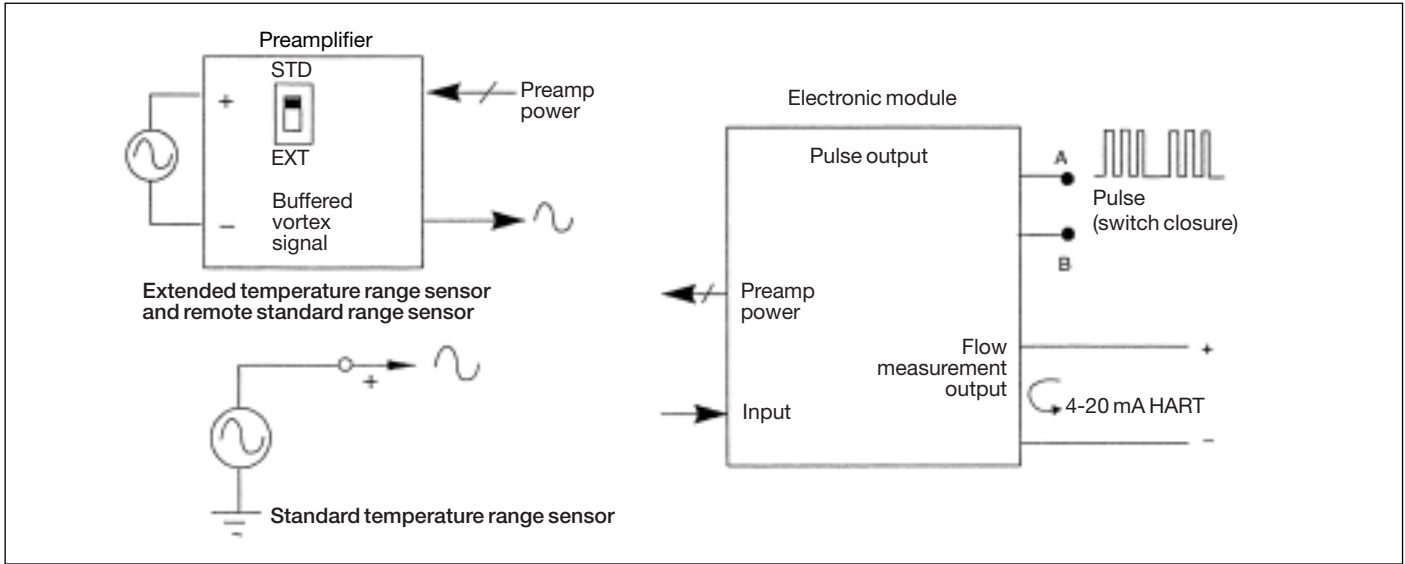

Figure 16. VFM 3100 Block Diagram

4.2. Electronic Module

The electronic module is made up of three printed wiring assemblies (PWAs) and two captive screws. The electronic module is housed in the transmitter housing opposite the side labeled “FIELD TERMINALS.” On the back of the module are three terminal blocks. See Table 10 for a summary of the terminal block connections.

Table 10. Electronic Module Terminal Block Connections

Number of Connectors	Letter Code	Color	Description
2	R B	Red Blue	Loop + Loop -
2	Y G	Yellow Green	Scaled Pulse Out + Scaled Pulse Out -
4	B R O Y	Brown Red Orange Yellow	Sensor + or Preamp Out + Preamp Power + Preamp Power - Sensor - or Preamp Out -

4.2.1. Electronic Module Removal

- Remove power from the VFM 3100.
- Remove electronic module compartment threaded cover.
- Unscrew the two captive screws, one on each side of the electronic module.

Standard Temperature Range VFM 3100

- Pull the electronic module out of the housing far enough to be able to disconnect the brown and yellow sensor leads from the terminal block on the back of the electronic module. Disconnect the four output signal leads (red [+], and blue [-], and yellow and green) at the two terminal blocks on the electronic module. See Figure 17.
- For remote mounted VFM 3100, remove all four preamplifier wires from the terminal block. Refer to Figure 18.
- Remove the electronic module from housing.

NOTE: Do not cut the plastic tie wraps.

Extended Temperature Range VFM 3100

The Extended Range electronic module has a preamplifier mounted under the electronic module. Do not dislodge the preamplifier.

- Pull the electronic module out of the housing far enough to be able to disconnect the four preamplifier leads (brown-red-orange-yellow cable) from the terminal block on the electronic module and the four signal leads (red-blue, yellow-green). See Figure 18.
- Remove the electronic module from the housing

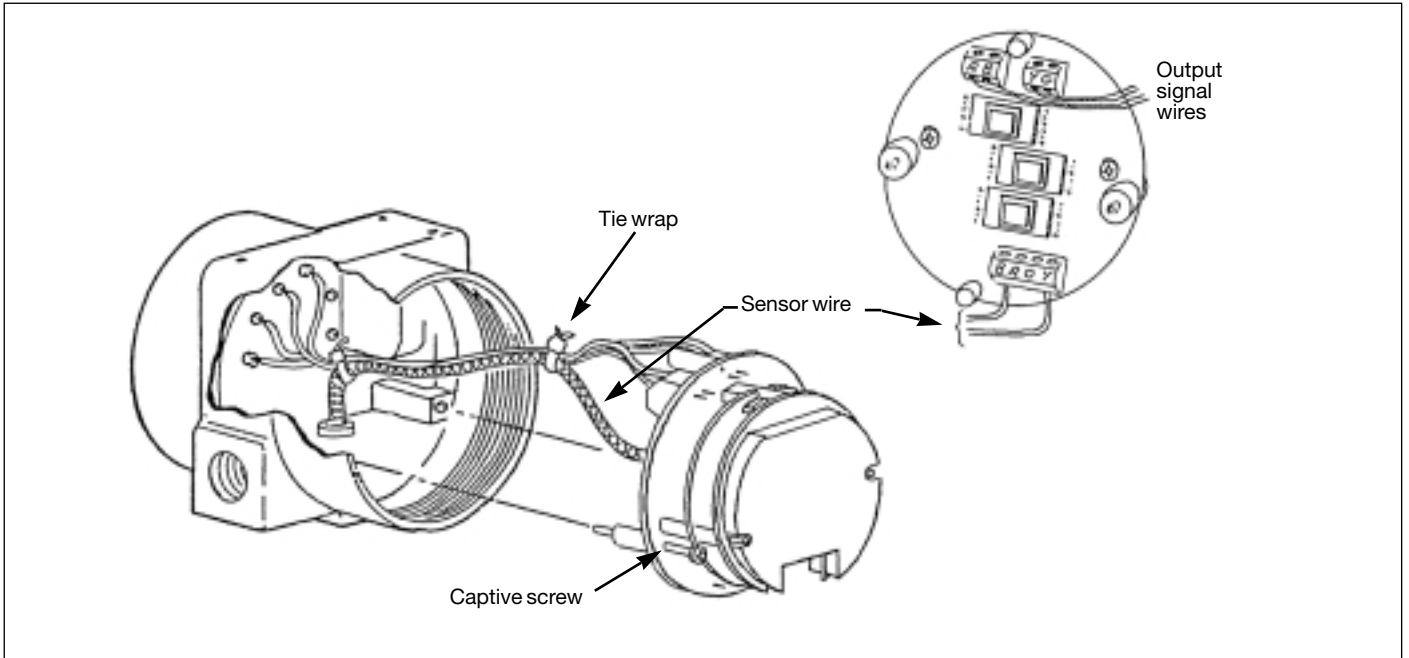

Figure 17: Electronic Module Connections - Standard Temperature Range (Integral Mount)

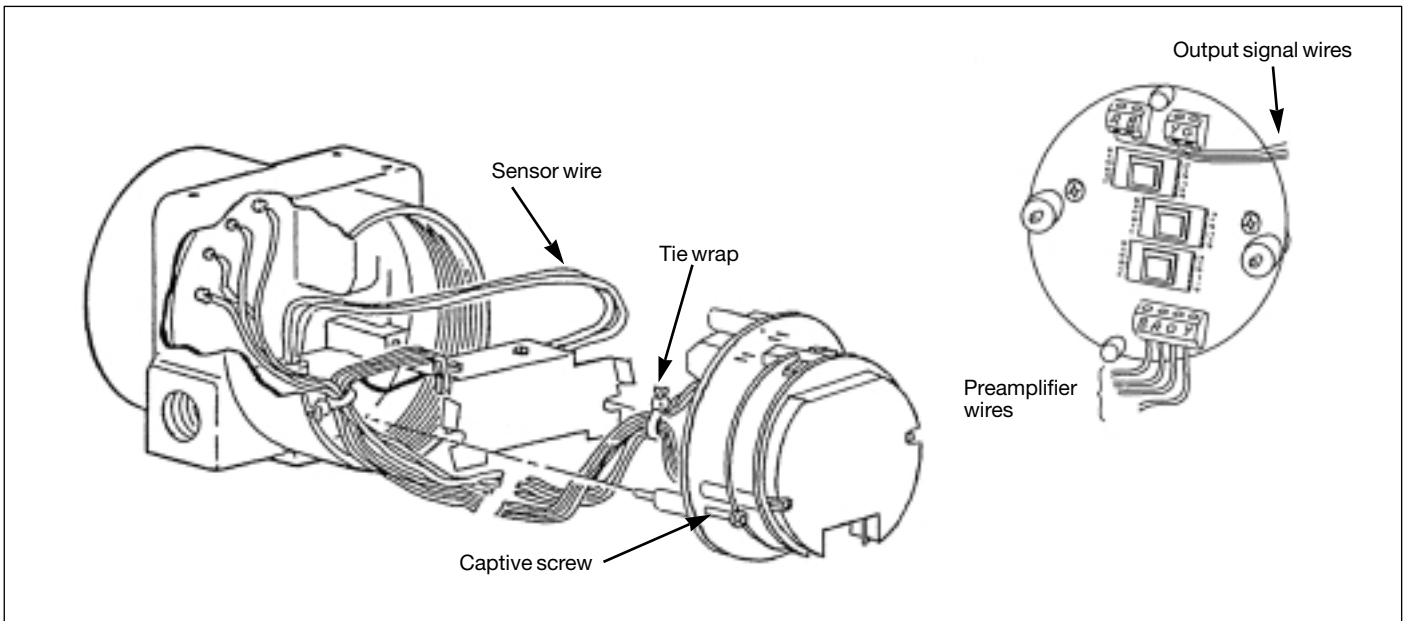

Figure 18: Electronic Module Connections - (Extended Temperature Range)

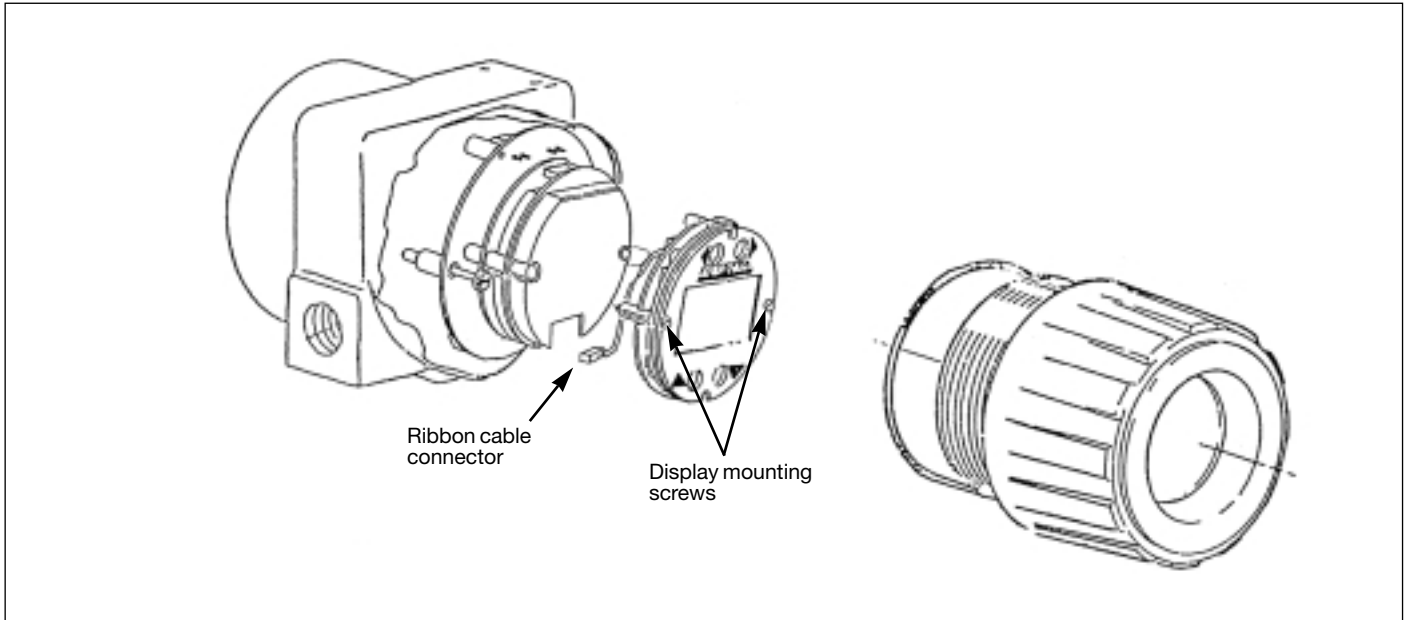

Figure 19. Electronic Module with Display Connections

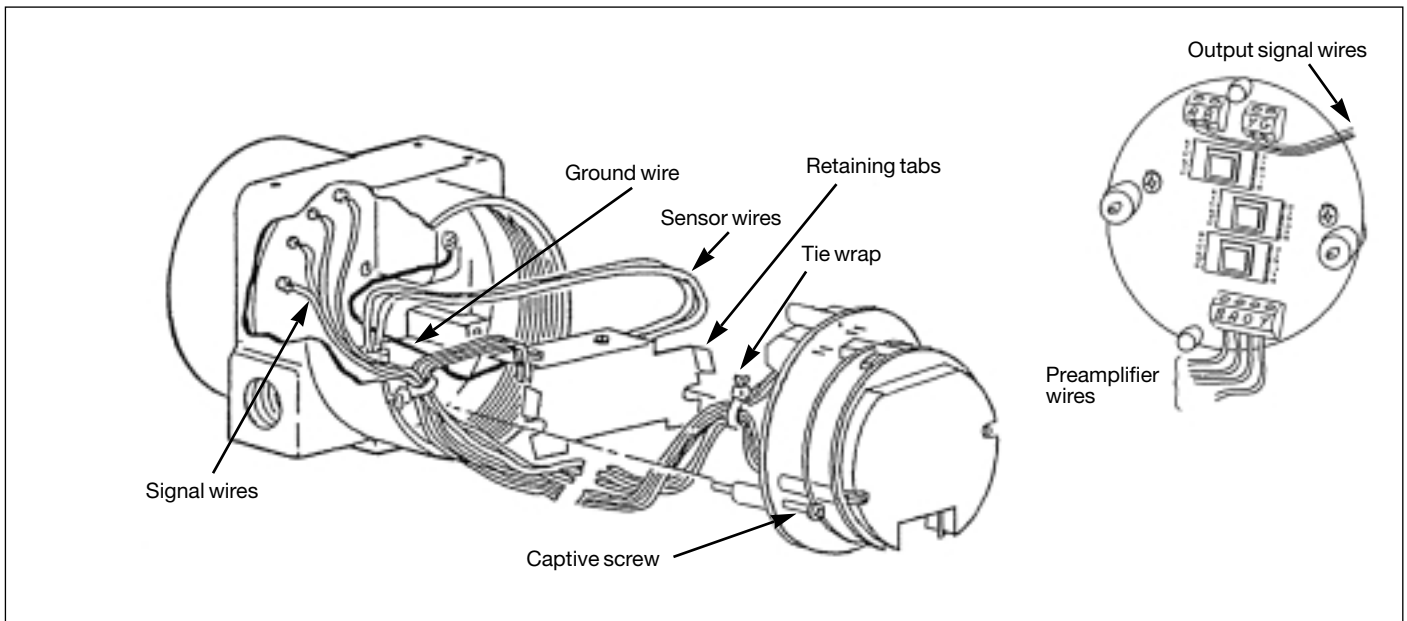

Figure 20. Electronic Module Connections - CENELEC Certified Extended and Standard Temperature Range.

Note: Do not cut the plastic tie wraps.

CENELEC Certified VFM 3100 Electronic Module Removal

The electronics of the CENELEC certified flameproof version are similar to the Extended Temperature Range VFM 3100. The CENELEC version has a housing with locking covers on both the electronic module and field terminal sides.

- Remove power from the VFM 3100.
- Take off the cover lock assemblies by removing the two M6 socket cap screws with a 5 mm hexagonal wrench. Save these lock assemblies.
- Once the lock assemblies are off, remove the electronic module cover. Unscrew the two captive screws (one on each side of the electronic module). See Figure 20.

- Pull the electronic module far enough out of the housing to disconnect the preamplifier leads (brown-red-orange-yellow cable) from terminal block on the electronic module and to disconnect the signal lead (red-blue, yellow-green cables) from the terminal blocks. Do not disconnect ground wire from housing.
- Remove electronic module from housing.

NOTE: Do not cut the plastic tie wraps.

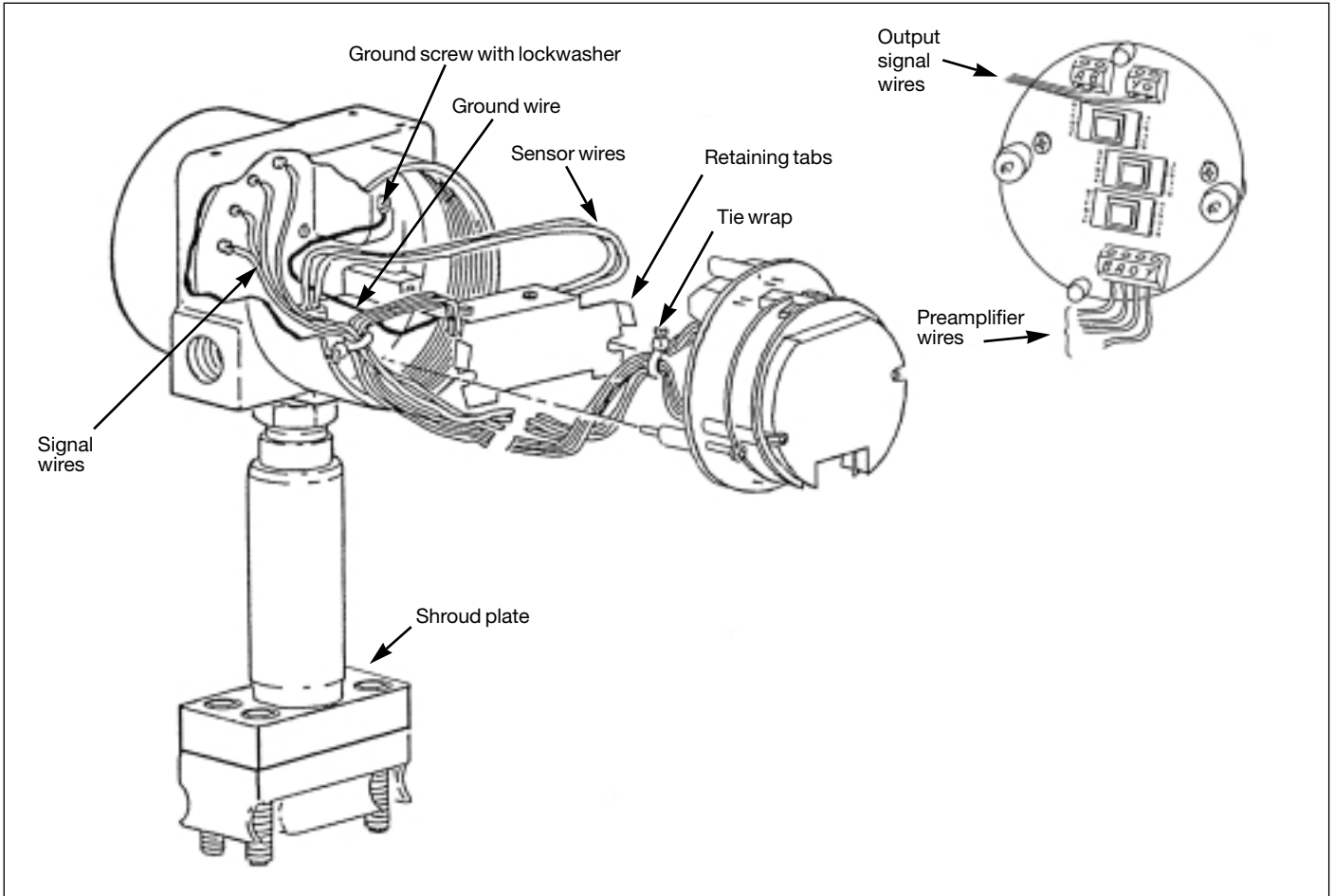

Figure 21. Electronic Module - CENELEC Certified Flameproof

4.3. Electronic Module Replacement

CAUTION: Ensure that power is not applied to the VFM 3100 before proceeding.

- Remove the electronic module following the appropriate procedure starting on page 30.

NOTE: If a display is mounted to the electronic module, remove the display, loosen the two mounting screws, and unplug the ribbon cable from the electronic module. See Figure 19.

NOTE: The replacement electronic module is shipped in a protective antistatic plastic bag. Do not remove it from this bag until it is ready to be installed in a VFM 3100. This will minimize the possibility of damage due to accidental electrostatic discharge. Use of an electrostatic mat will prevent electrostatic discharge.

- Remove the new electronic module from its protective bag. The procedure for connecting the sensor and signal leads see section below.

NOTE: The signal and sensor leads should already be held together with a plastic tie.

Standard Temperature Range VFM 3100

- Refer to Figure 17. Connect the brown and yellow sensor wires to the color coded terminal block on the back of the electronic module.

Extended Temperature Range VFM 3100 (including CENELEC Flameproof)

- Refer to Figure 18. Connect brown-red-orange-yellow preamplifier cable to the color coded terminal block on back of the electronic module. For CENELEC flameproof version, also connect the ground wire from the preamp to the housing as shown in Figure 21.
- Connect the signal leads (red-blue and yellow-green cables) to the terminal blocks on the electronic module following the color code on the label.
- After all the wires are connected, rotate the electronic module one full turn clockwise before mounting. This will help prevent the wires from being pinched. Locate the electronic module in the housing over the two mounting holes. If a preamp is present, be sure to align it also. Tighten the captive mounting screws.
- If the electronic module was equipped with a display, re-assemble the display. Carefully fold the ribbon cable in the space between display and the electronic module and tighten the mounting screws.
- The new electronic module must be configured to match the one just removed.
- Refer to the appropriate appendix for configuration.
- Perform post-assembly dielectric test. Refer to page 37. When calibration is complete, replace the housing covers.

NOTE: For CENELEC only, attach lock assemblies on both sides of the electronics housing prior to operating the VFM 3100.

4.4. Preamplifier

The Preamplifier assembly (shown in Figure 22) consists of the preamplifier with a shield for integral mounted electronics (or with a mounting plate for remote mounted electronics, as shown in Figure 23). The preamp has a sensor switch which must be set to STD for standard temperature sensors and set to EXT for extended temperature range sensors.

4.4.1. Preamplifier Removal Integral Mounted VFM 3100

- Disconnect power from the VFM 3100.
- Remove electronic module compartment cover (opposite “Field Terminal” side) and remove the electronic module as described starting on page 30. Remove the brown, red, orange and yellow preamplifier leads. Refer to Figure 18. It is not necessary to remove the display, if one is present.
- Cut the two tie wraps holding the preamplifier leads and signal leads together.
- Pry the retaining tabs of the metal shield away from the housing, using a straight blade screwdriver, and pull the whole assembly out. See Figure 22.
- Turn the preamplifier upside down, disconnect the yellow and brown sensor leads from the terminal block, and loosen the strain relief clamp that holds the sensor cable.
- Pull the preamplifier out of the housing.

NOTE: For CENELEC certified flameproof VFM 3100, disconnect preamplifier ground lead from housing. Save screw and lockwasher. See Figure 21.

- Remove the Preamplifier from the shield by removing the two screws. See figure 22. Save the two screws and metal shield.
- The replacement procedure starts on page 35.

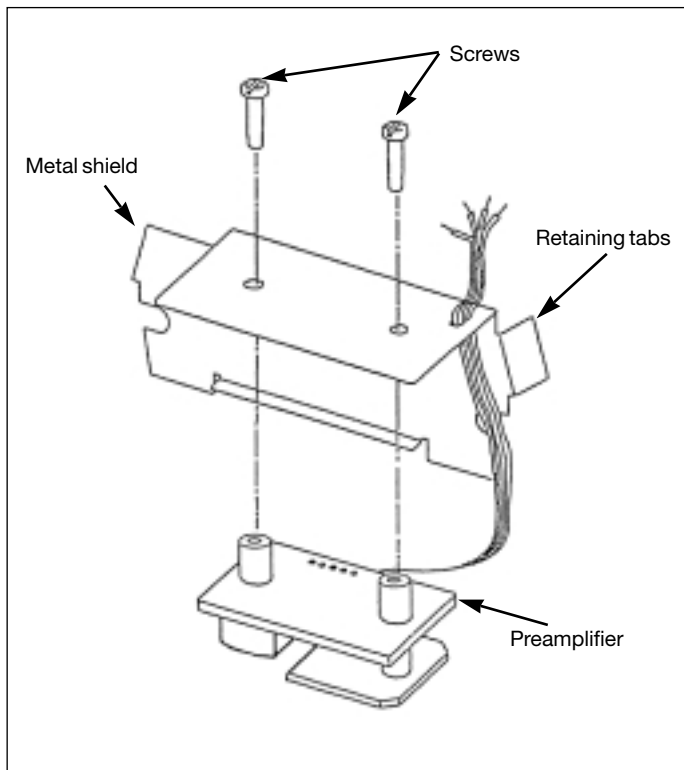

Figure 22. Preamplifier Assembly - Integral Mount Extended Temperature Range

Remote Mounted VFM 3100

See next section for remote mounted CENELEC version.

On remote mounted electronics, the Preamplifier is housed in the junction box on top of the VFM 3100. The Electronic Module is in the transmitter housing.

- Disconnect power to the VFM 3100.
- Remove the junction box cover. The Preamplifier and a 4-position two-sided terminal block are mounted on a round plate in the junction box, as shown in Figure 23.
- Disconnect (brown-red-orange-yellow) wires from both sides of the terminal block and remove strain clamp holding remote cable.
- Disconnect yellow and brown sensor leads from terminals on the preamplifier and loosen strain relief clamp holding the sensor cable.
- Unscrew the two mounting screws to remove the mounting plate from the junction box.
- Turn the mounting plate (with the preamplifier) upside down and unscrew the two screws to remove the preamplifier. Save the screws and the mounting plate assembly.

Remote Mounted CENELEC Certified Flameproof VFM 3100

- Remove power from the VFM 3100. The transmitter and junction box of a remote mounted CENELEC certified flameproof VFM 3100 have locks on their covers as shown in Figure 24.
- To remove the Preamplifier, remove lock assembly of junction box and remove cover. The Preamplifier with a metal shield over it, a 4-position two-sided terminal block, and metal ground strap are mounted on a round plate in the junction box.

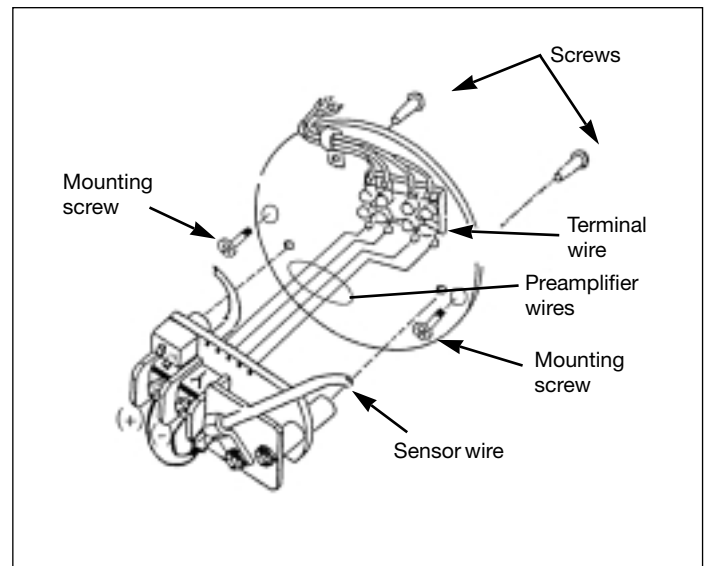

Figure 23: Preamplifier Assembly - Remote Mount Assembly.

- Remove shield covering the Preamplifier and disconnect the ground lead from U-shaped metal strap on the mounting plate (Figure 24).
- Disconnect (brown-red-orange-yellow) wires from both sides of the terminal block and remove strain relief clamp holding remote cable. Refer to Figure 23.
- Disconnect yellow and brown sensor leads from terminal block on the preamplifier and loosen strain relief clamp holding the sensor cable.
- Unscrew the two mounting screws to remove mounting plate from junction box.
- Turn the mounting plate (with preamplifier) upside down and unscrew the two screws to remove preamplifier. Save the screws, mounting plate assembly, cover lock assembly, preamplifier shield with screws, and ground strap.

4.4.2. Replacing the Preamplifier

The replacement preamplifier is shipped in a protective anti-static plastic bag with two tie wraps for dressing of wires. Do not remove the preamplifier from this bag until it is ready to be installed in a VFM 3100. This will prevent damage due to accidental electrostatic discharge.

NOTE: An electrostatic mat will prevent electrostatic discharge

Remove the new preamplifier from its protective bag and follow the installation procedure in "Integral Mounted VFM 3100" on page 36 and in "Remote Mounted VFM 3100" on page 36.

CAUTION: Before proceeding, make sure that power to VFM 3100 is OFF.

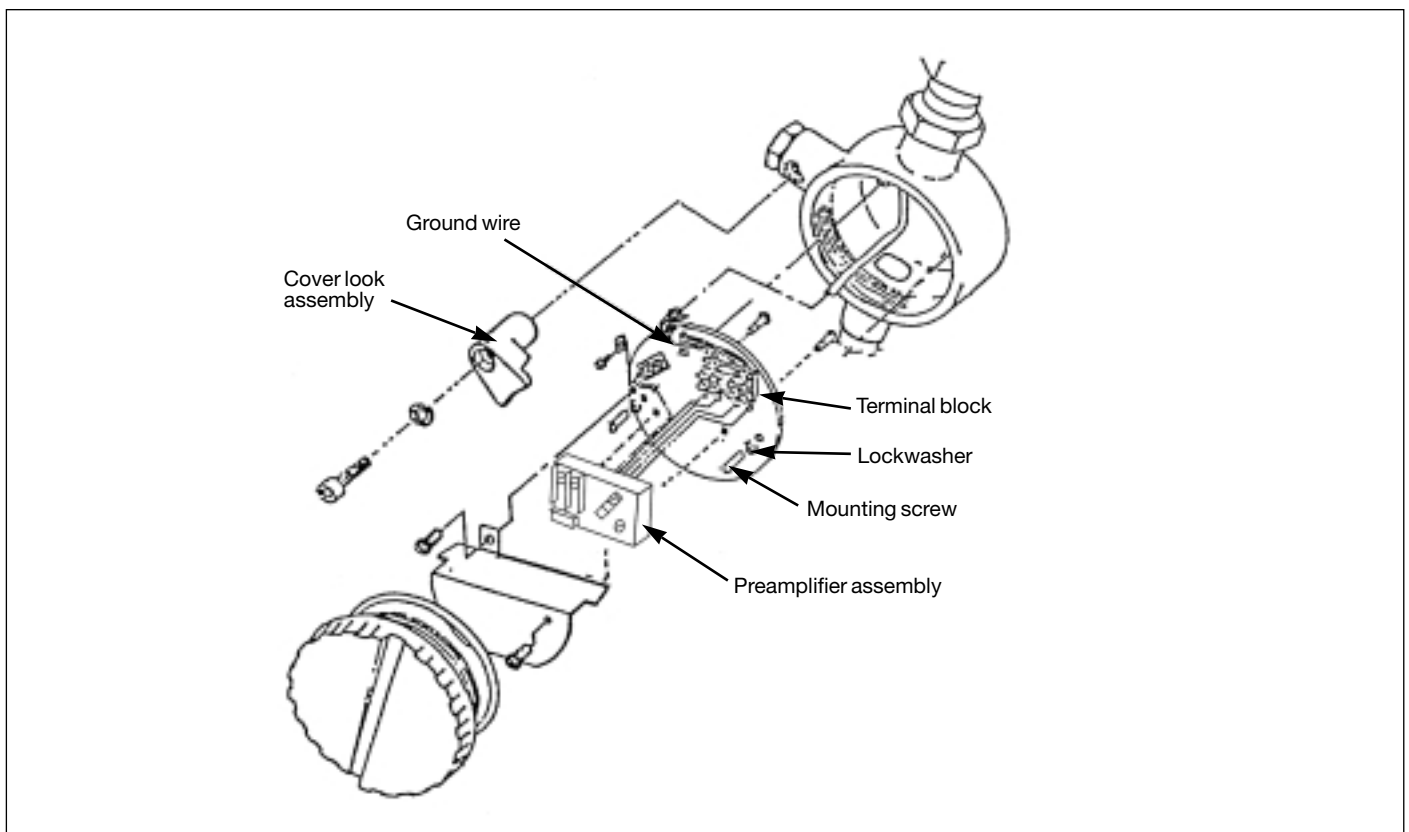

Figure 24: Preamplifier - Remote Mounted VFM 3100 (CENELEC Certified Flameproof)

Integral Mounted VFM 3100

- Mount the new preamplifier to the metal shield using the original screws. See Figure 22.
- Feed the yellow and brown sensor wires through the strain relief clamp on the bottom of the preamplifier board. Tighten the clamp and connect the sensor leads to the terminal block. The color coding is important. Check to see that this is correct. See Figure 25.
- Set the sensor switch to “STD” for standard temperature sensors and to “EXT” for extended range temperature sensors.
- Before placing the preamplifier into the housing, bend the retaining tabs of the metal shield outward slightly to ensure a snug fit against the housing walls. See Figure 18. Align the mounting slots with the screw holes for mounting the electronic module.
- Once the preamplifier is in place, connect its four wires (brown-red-yellow-orange cable) to the color coded terminal block on back of the electronic module.
- Connect the output signal leads (red-blue, and yellow-green cables) to terminal blocks on the electronic module, following the color code on the label.
- Prior to mounting the main electronic module in the housing, bring all the cables from preamplifier and the housing neatly together as shown in Figure 18.
- While pushing the slack in the cables away from the back of the electronic module, tie the cables together at two places, using plastic tie wraps.
- Locate the electronic module in the housing by aligning the preamplifier shield with the mounting holes.

- Rotate the electronic module one full turn clockwise before mounting. This will help prevent the wires from being pinched. Locate the electronic module over the mounting holes, align the preamplifier, and tighten the captive mounting screws.
- Perform Post-Assembly Dielectric Test. Refer to page 37. Replace threaded housing cover.

Remote Mounted VFM 3100

- Mount the new preamplifier on the mounting plate using the two screws. Refer to Figure 23.
- Feed the yellow and brown sensor wires through the strain relief clamp on the preamplifier board. Tighten the clamp and connect the sensor leads to the terminal block. The color coding is important. Verify that it is correct. See Figure 25.
- Connect (brown-red-orange-yellow) cable from preamplifier to one side of the two-sided terminal block on the mounting plate. See Figure 23.
- Before placing assembly into the junction box, connect the four (brown-red-orange-yellow) wires entering the junction box through a conduit opening, to the other side of the terminal block on the mounting plate (following the same sequence as the cable from the preamplifier). See Figure 26.
- Place mounting plate with preamplifier in the junction box and mount it using the two mounting screws.
- Perform Post-Assembly Dielectric Test. Refer to page 37. Replace the threaded junction box cover.

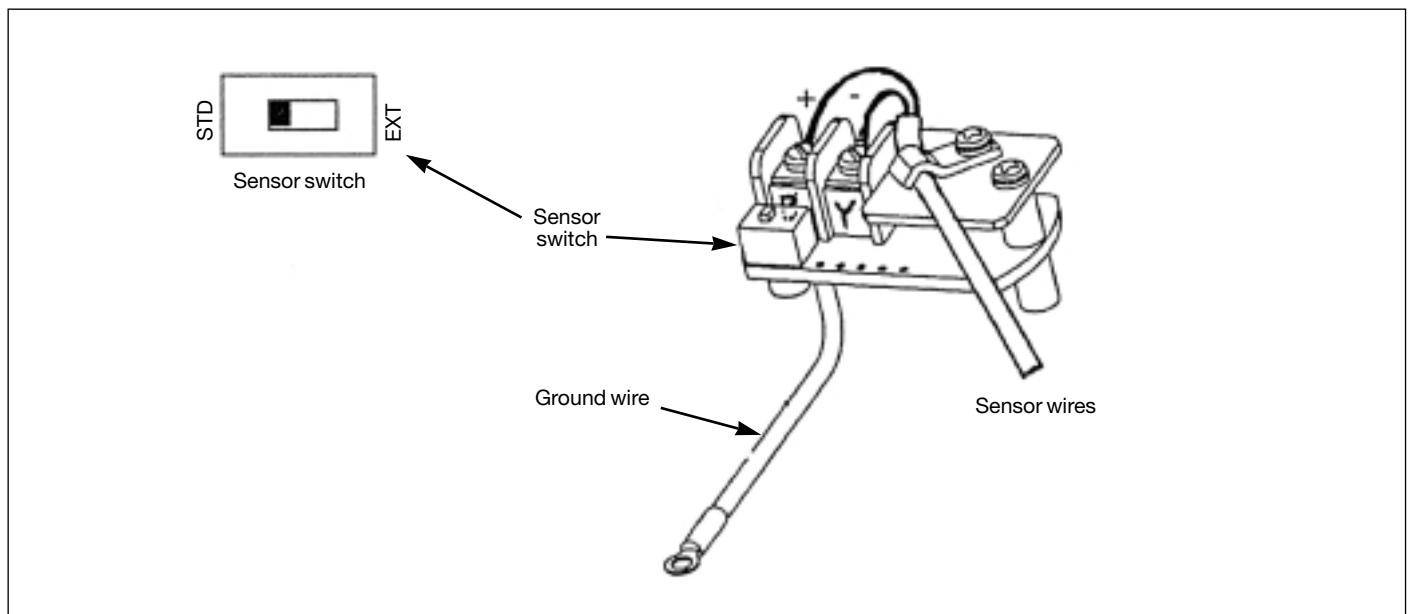

Figure 25. Preamplifier Assembly

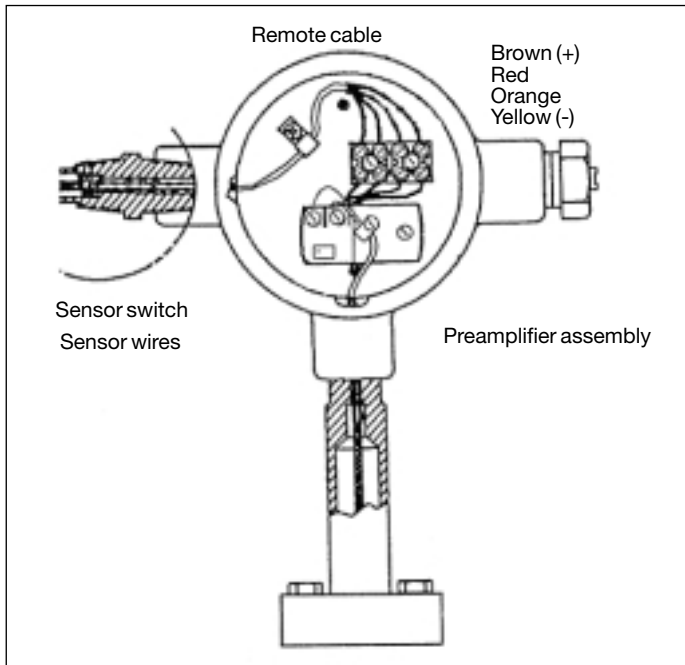

Figure 26. Pre-amplifier – Remote Mounted VFM 3100

Remote Mounted VFM 3100 (CENELEC Certified Flameproof)

- Mount the new pre-amplifier on the mounting plate using the two screws. Refer to Figure 23.
- Feed the yellow and brown sensor wires through the strain relief clamp on the pre-amplifier board. Tighten the clamp and connect the sensor leads to the terminal block. The color coding is important. Check to see that this is correct. See Figure 25.
- Connect (brown-red-orange-yellow) cable from the pre-amplifier to one side of the two-sided terminal block on the mounting plate.
- Before placing assembly into the junction box, connect the four (brown-red-orange-yellow) wires entering the junction box through a conduit opening, to the other side of the terminal block on the mounting plate (following the same sequence as the ribbon cable from the pre-amplifier). See Figure 23.
- Place mounting plate with pre-amplifier in the junction box and mount it using the two mounting screws.
- Connect ground wire from the pre-amplifier to the U-shaped ground strap on the mounting plate.
- Mount metal shield over the pre-amplifier as shown in Figure 24.
- Replace the junction box cover and add the lock assembly.

4.5. Post-Assembly Dielectric Test

To ensure there are no faults to ground in any of the internal wiring, apply 500 V ac or 707 V dc dielectric strength test for 1 minute between shorted input terminals (+), (-), (A), (B), and housing ground as shown in Figure 27.

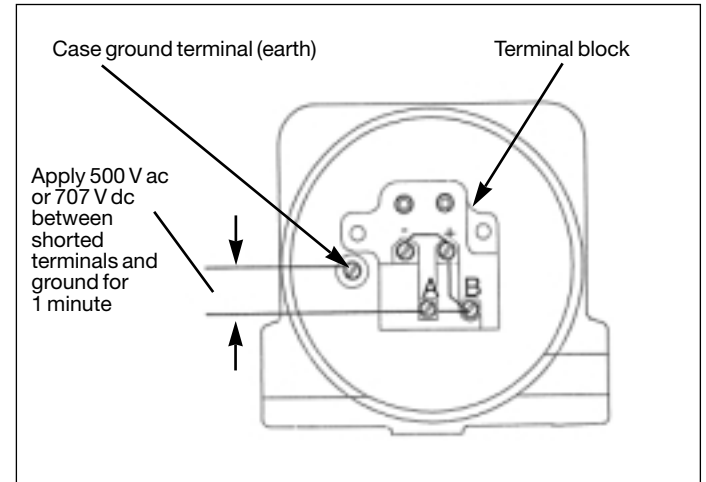

Figure 27. Connections for Post-Assembly Dielectric Test

4.6. Sensor Replacement with Integral Electronic Module

The VFM 3100 does not need to be removed from the pipeline for Sensor replacement. The pipeline must, however, be shut down and emptied before loosening the connector bolts.

4.6.1. Disassembly

- Disconnect power from the VFM 3100. If the VFM 3100 is wired with rigid conduit, it may be necessary to remove the field terminal cover and disconnect input wiring and conduit connections.
- Remove electronic module compartment cover. (For CENELEC Certified Flameproof Extended Range VFM 3100, remove lock assembly prior to removing the housing covers.)

NOTE: If cover cannot be removed by hand, it may be necessary to insert a flat bar in tapered cover slot to remove.

- Remove the electronic module and pre-amplifier and disconnect the sensor leads per the instructions starting on page 30 for meters with integrally mounted electronics housings.
- Remove the mechanical connector bolts and lift off the electrical housing, mechanical connector, and sensor as a unit. See Figure 28.
- Slide the sensor out of the mechanical connector. See Figure 30.

NOTE: The Standard Temperature Range VFM 3100 has a ptfе gasket and flow dam and a silicone rubber O-ring. The Extended Temperature Range VFM 3100 has a stainless steel gasket and flow dam and a Graphoil O-ring.

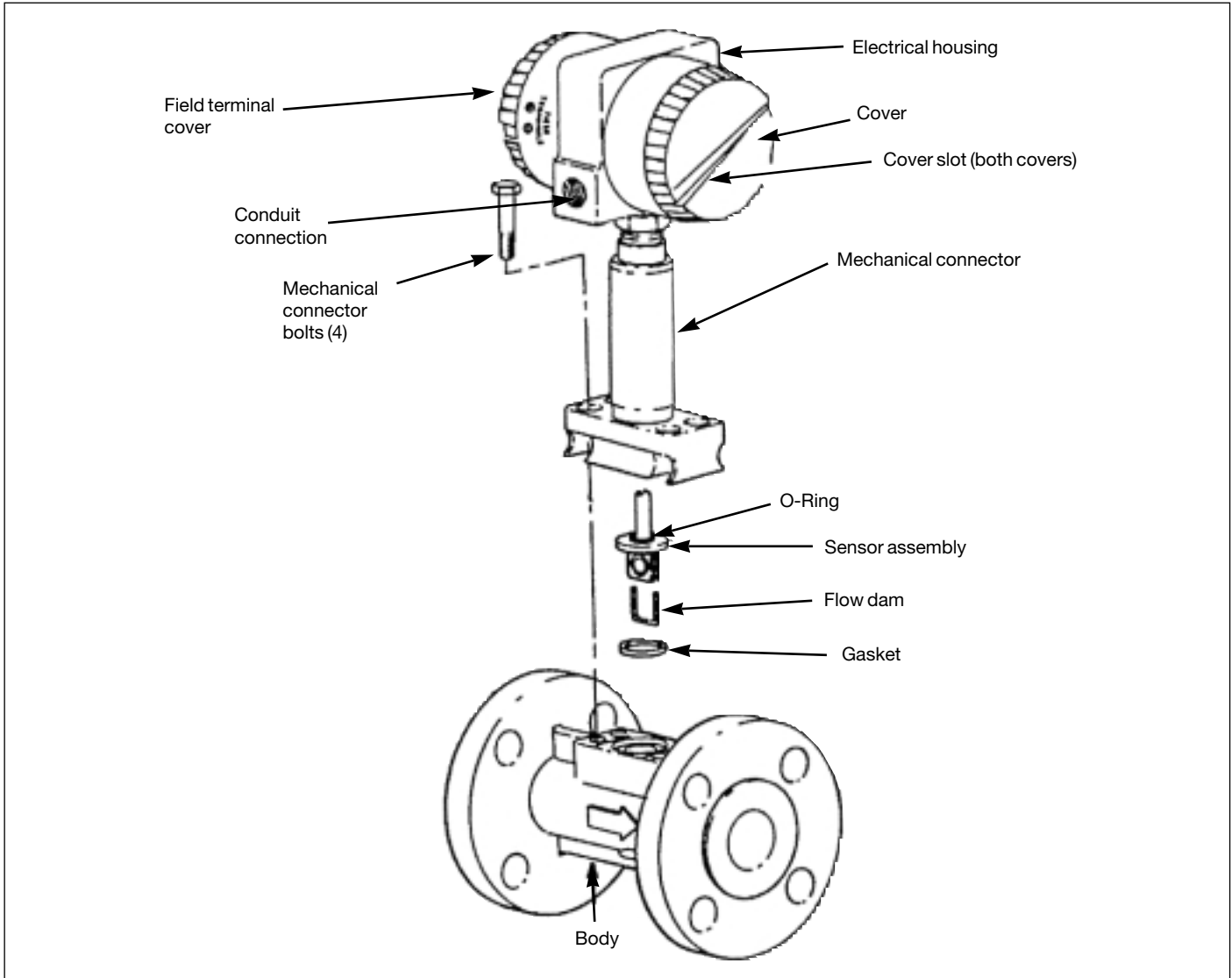

Figure 28. VFM 3100 Assembly

4.6.2. Replacing the Sensor

NOTE: Before beginning the assembly procedure, verify that you have the correct kit of parts.

The sensor kits consist of:

- 1 Sensor Assembly
- 1 O-ring
- 1 Gasket
- 1 Flow Dam
- 2 Tie Wraps

The following steps apply to both Standard and Extended Temperature Range VFM 3100:

- If the flow dam has remained in the VFM 3100 body, remove it before starting to re-assemble.
- Slide O-ring over sensor lead and onto neck of sensor. See Figure 29.
- Carefully feed sensor lead through hole in mechanical connector and gently pull sensor lead out of electrical housing until sensor is touching the mechanical connector. See Figure 31.
- Place the flat gasket over the sensor in contact with serrated sealing surface. Center the gasket. Slide the flow dam into the groove of the sensor.
- Insert the sensor with the connector into the VFM 3100 body and assemble the four bolts finger tight.

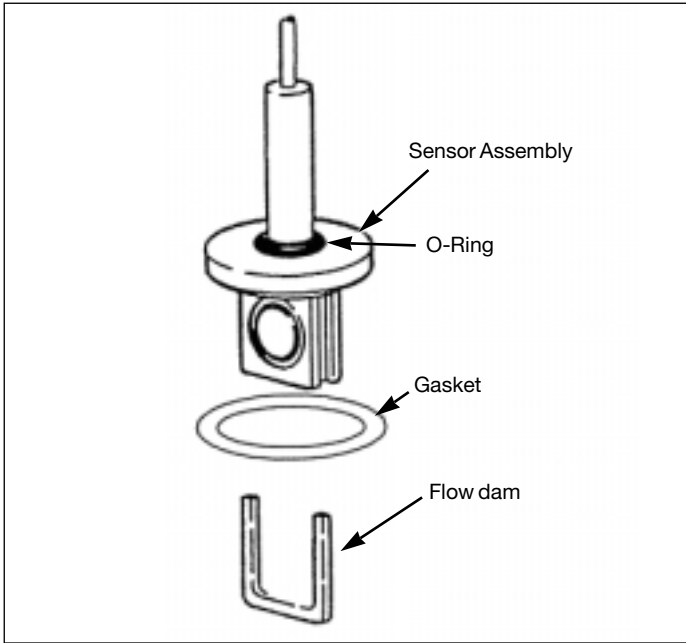

Figure 29. O-Ring/Sensor/Flow Dam

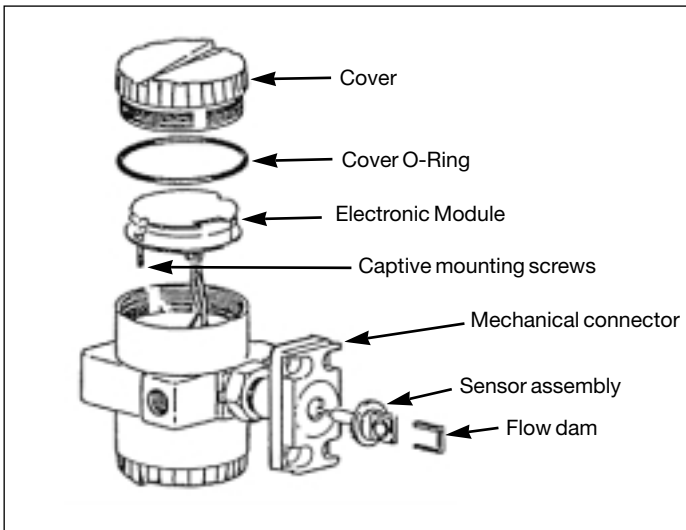

Figure 30: Electrical Housing/ Mechanical Connector

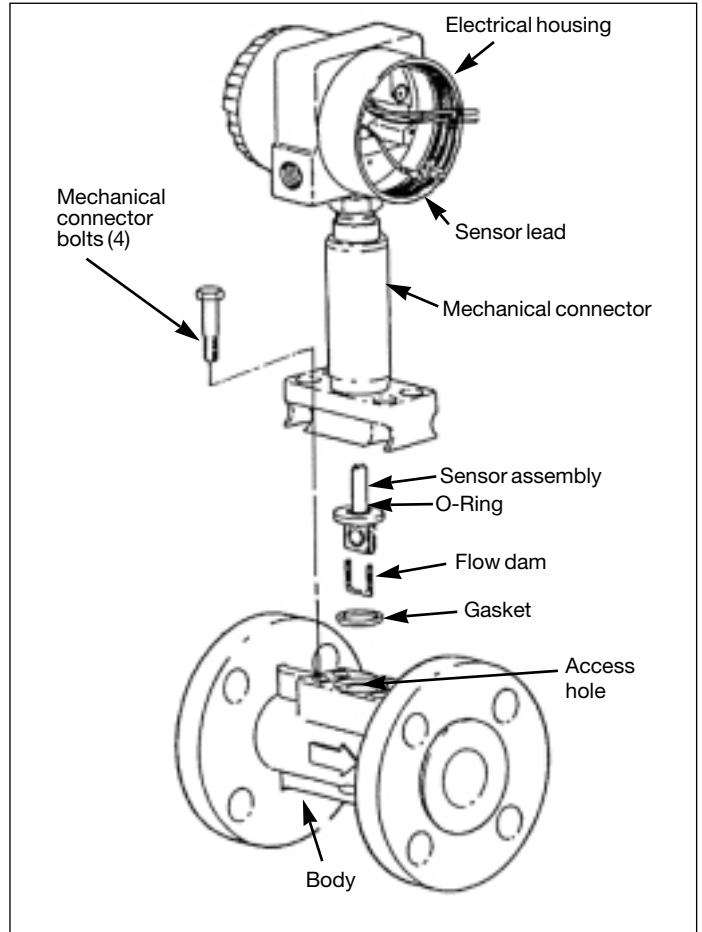

Figure 31: VFM 3100 Assembly

WARNING: It is important that the gasket be sealed uniformly to provide a good seal. The following steps will assure a uniform seal. Failure to follow these steps could result in personal injury due to gasket leakage.

- Tighten all connector bolts in steps of 1.2 Nm (1 lb•ft) up to 2.8 Nm (2 lb•ft) per the sequence shown in Figure 32. For example,

$$\frac{1.2}{1}$$

means 1.2 Nm or 1 lb•ft.

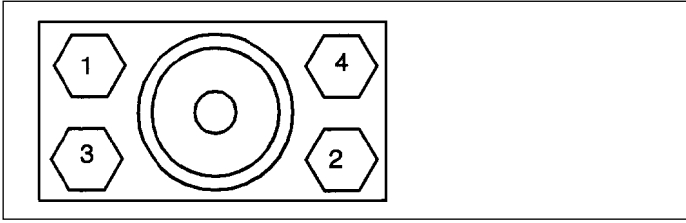

Figure 32: Connector Bolt Torquing Sequence

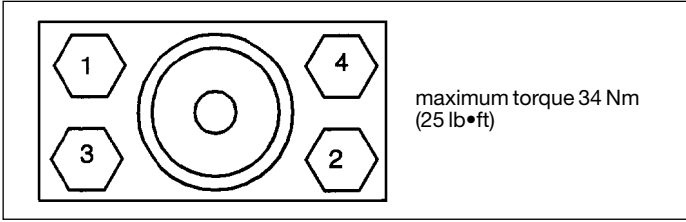

Figure 33: Connector Bolt Torquing Sequence

- Continue to tighten in steps of 7 Nm (5 lb•ft) using the same sequence. The maximum torque needed for safe operation is 34 Nm (25 lb•ft) per Figure 33.
- Reassemble the Electronic Module and preamplifier per instructions starting on page 33. Attach conduit connections and input wiring. See “Field Termination” on page 19 and “Interconnection Wiring for Remote Electronics” on page 13.

NOTE: Replacing the sensor will not cause a shift in the K-factor.

WARNING: In order to maintain agency certification of this product and to prove the integrity of the parts and workmanship in containing process pressure, a hydrostatic pressure test must be performed. The VFM 3100 must hold for 1 minute without leaking the appropriate pressure from Table 11.

Table 11. Maximum Test Pressure

Model	End Connection	Test Pressure
VFM 3100 F - T	ANSI Class 150 PN 16	450 psi 3,2 MPa
VFM 3100 F - T	ANSI Class 300 PN 40	1125 psi 6 MPa
VFM 3100 F - T	PN 64	9,6 MPa
VFM 3100 F - T	ANSI Class 600 PN 100	2250 psi 15 MPa
VFM 3100 W-T	All	15 MPa (2250 psi)

4.7. Sensor Replacement with Remote Electronic Module

4.7.1. Disassembly

- Remove junction box cover (for CENELEC Certified Flameproof VFM 3100, remove lock assembly and cover). See Figure 24.
 - Standard Temperature Range Sensor: Loosen strain relief clamp. Disconnect yellow and brown sensor leads from terminal block. See Figure 34.
 - Extended Temperature Range Sensor: Disconnect brown and yellow sensor lead from terminal block on preamplifier. See Figure 35. (For CENELEC Certified Flameproof VFM 3100, remove preamplifier shield and then disconnect the sensor leads from preamplifier.)
- Do not disconnect the interconnecting wiring to the remote Electronic Module assembly.
- See Figure 36. Remove mechanical connector bolts. (CENELEC Certified Flameproof VFM 3100 have special connector bolts as well as a shroud plate over the standard connector. Once the bolts are removed, the shroud plate is retained between the connector and housing.)
- Lift the junction box mechanical connector and sensor as a unit.
- Slide the sensor and out of the mechanical connector as shown in Figure 37.

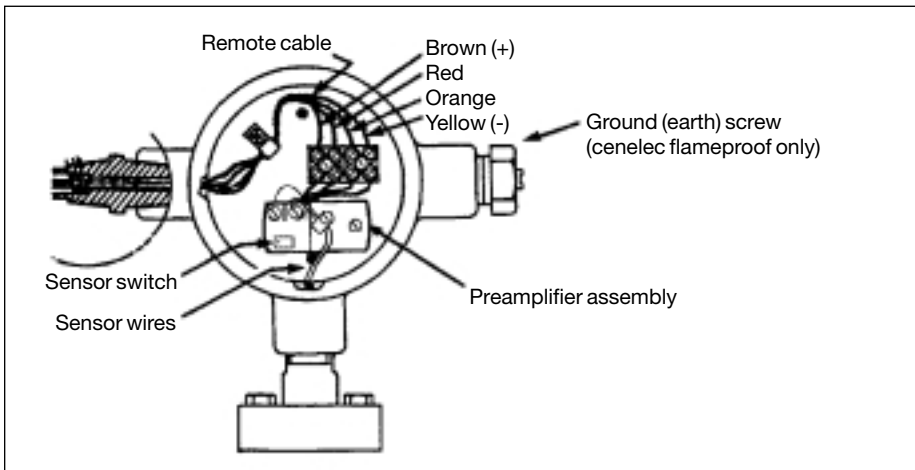

Figure 34: Flowtube/Junction Box - Standard Temperature Range

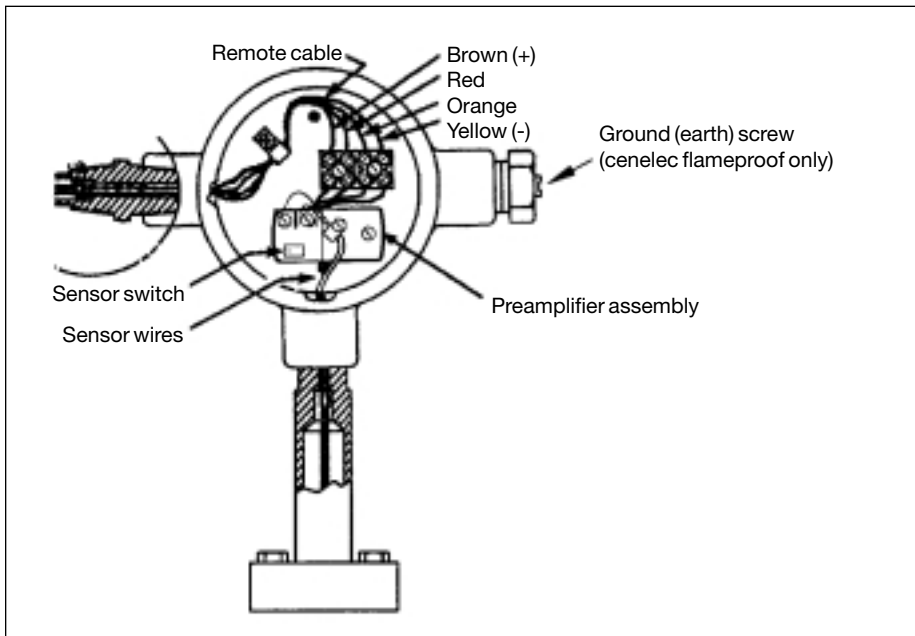

Figure 35: Flowtube/ Junction Box - Extended Temperature Range

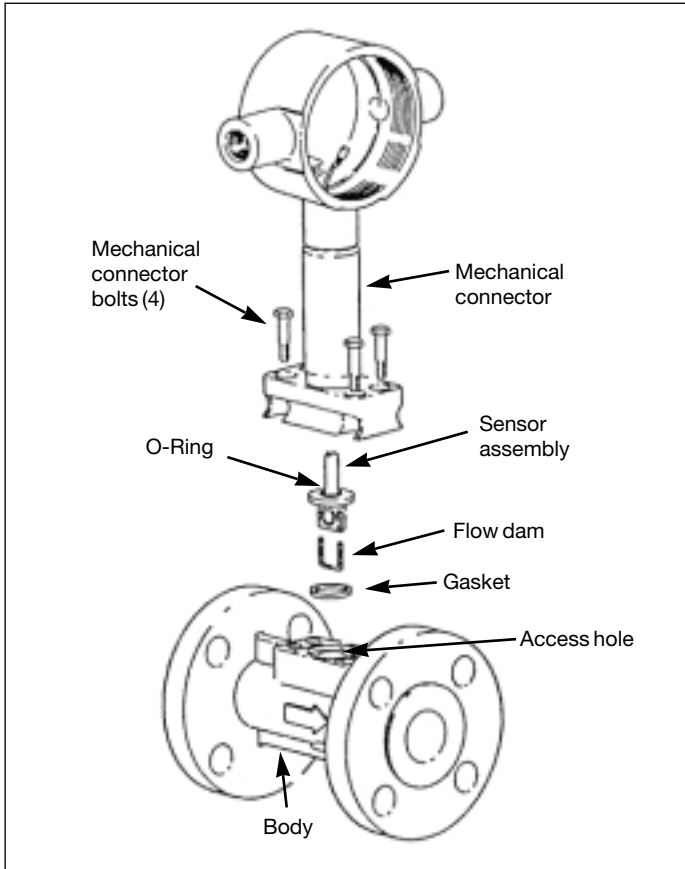

Figure 36. VFM 3100 Assembly/Junction Box

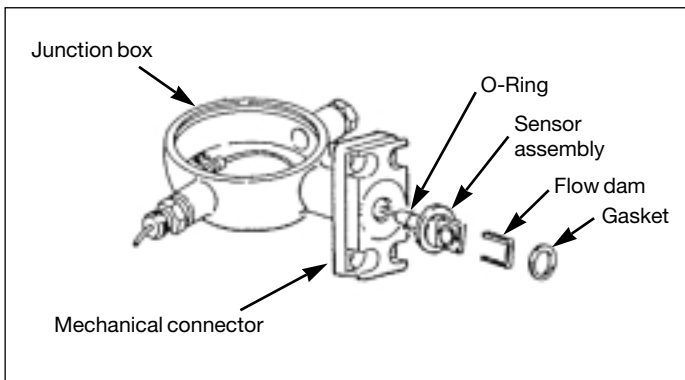

Figure 37. Sensor/Mechanical Connector/Junction Box

4.7.2. Assembly

NOTE: Before beginning the assembly procedure, verify that you have the correct kit of parts.

The sensor kits consist of:

- 1 Sensor Assembly
- 1 O-ring
- 1 Gasket
- 1 Flow Dam

Slide O-ring over sensor lead and onto neck of sensor. See Figure 29.

The following steps apply to both Standard and Extended Temperature Range VFM 3100:

- If the flow dam has remained in the VFM 3100 body, remove it before starting to reassemble.
- Carefully feed sensor lead through hole in mechanical connector and gently pull sensor lead out of junction box until sensor is touching the mechanical connector. See Figure 37.

CAUTION: For CENELEC certified flameproof units, take special care not to scar, mar, ding, or dent the surface of the sensor stem during assembly. This is critical to the integrity of the flameproof surface finish.

- Place the flat gasket over the sensor in contact with the serrated sealing surface. Center the gasket. Slide the flow dam into the groove on the sensor.
- Insert the sensor with the connector into the VFM 3100 body and assemble the four bolts finger tight.

WARNING: It is important that the gasket be sealed uniformly to provide a good seal. The following steps will assure a uniform seal. Failure to follow these steps could result in personal injury due to gasket leakage.

- Tighten all connector bolts to 3.4 Nm (25 lb•ft) per the procedure starting on page 40. Refer to Figures 32 and 33.
- Attach conduit connections and input wiring. See "Field Termination" on page 19.

NOTE: Replacing the sensor will not cause a shift in the K-factor. Therefore, the VFM 3100 does not require recalibration.

- Connect the sensor wires to the color coded terminals as shown in Figure 34 for the Standard Temperature Range sensor and in Figure 35 for the Extended Temperature Range sensor.

WARNING: In order to maintain agency certification of this product and prove integrity of the parts and workmanship in containing process pressure, a hydrostatic pressure test must be performed. The VFM 3100 must hold for 1 minute without leaking the appropriate pressure from Table 11, "Maximum Test Pressure," on page 40.

5. Determining Special Measuring Units

There may be a need to use flow units that are not listed in the units menu. To enter custom units, select "special" from the flow and/or total units menu.

The following four entries are required to configure the transmitter for special flow and total units.

- Total name, maximum six characters, is required for displaying total.
- Flow name, maximum six characters, is required for displaying the flow rate.
- Total conversion factor for computing total.
- Flow conversion factor for computing flow.

The conversion factors must be related to the internal software and the manner in which the VFM 3100 computes flow. The conversion factor for total is a direct conversion from ft^3 to the desired units. The conversion factor for flow is a direct conversion from ft^3/sec to the desired flow units. Any table of conversion factors may be used.

Example: Barrels per hour

To measure total in barrels and flow in barrels per hour.

Total Name: bbl
Flow Name: bbl/h
Total Conversion Factor: 0.1781 bbl/ ft^3
Flow Conversion Factor: $0.1781 \times 3600 = 641.2$ bbl/h
where: $3600 = \text{sec/hr}$
Example: BTU per minute

The conversion factor for total must be in BTU/ft^3 . If the BTU factor is known in mass units, then it must be converted to volume units by multiplying by density. The flow factor is a direct conversion from ft^3/sec to the desired units.

Total Name: BTU
Flow Name: BTU/m
Total Conversion Factor: $(\text{BTU}/\text{lb}) \times \text{density}$
Flow Conversion Factor: $(\text{BTU}/\text{lb}) \times \text{density} \times 60$
where: $60 = \text{sec/min}$
Example: Calories per hour

The conversion factor for total must be in $\text{calories}/\text{ft}^3$. If the calories factor is known in cal/kg , it must be converted to cal/ft^3 by multiplying by the density and volume conversion factors (m^3 to ft^3). The flow factor must be related to ft^3/sec .

Total Name: cal
Flow Name: cal/h
Total Conversion Factor: $(\text{cal}/\text{kg}) \times \text{density} \times 0.028317$
where: $0.028317 = \text{m}^3/\text{ft}^3$
Flow Conversion Factor: $(\text{cal}/\text{kg}) \times \text{density} \times 0.028317 \times 3600$

6. Isolation Valves

Isolation valving is available in single and dual measurement versions for standard and extended range sensors. The following procedure applies to all versions. Replacing the sensor in this type of unit is essentially the same as replacing a sensor in units without isolation valving. However, particular care must be taken since the process does not need to be shut down.

WARNING: The isolation valve must be in the closed position prior to replacing the sensor. It must be gradually depressurized so that process fluid does not leak. Personal injury could result from such a leak. Follow normal lockout procedures. Remove power from the VFM 3100.

6.1. Replacing the Sensor

- Close the valve. This is a dual port, single ball 1/4-turn valve. Use a wrench on the flat on the valve stem to turn clockwise one quarter turn. See Figure 38.

NOTE: The right angle position indicator attached to the stem is not a valve handle. Use a wrench on the valve stem flats.

- Allow the unit to cool down as required.
- Remove power from the VFM 3100 and disconnect input wiring and conduit connections.
- Gradually loosen the four top bolts that connect the mechanical connector to top surface of the valve body. Do not loosen the bottom bolts.
- Allow trapped process fluid within valve body to depressurize.
- Remove the four connector bolts and lift off electrical housing, mechanical connector, and Sensor as a unit.

NOTE: If electronic housing cover cannot be removed by hand, it may be necessary to insert a flat bar in slot to remove.

- Proceed to remove the electronic module per instructions starting on page 30 and replace the sensor per instructions starting on page 38. Be sure the O-ring is installed on the sensor and use a new flow dam and gasket.
- When the new sensor has been installed, mount the sensor and mechanical connector to the valve body and tighten the bolts per instructions starting on page 38.
- Since it is not possible to leak test the valve-to-connector joint, it must be assembled carefully.
- Open the valve counterclockwise. Use care and check for leaks.
- Reinstall the electronic module and, when required, the preamplifier, using instructions starting on page 35.
- Reconnect the conduit and external wiring. Refer to instructions starting on page 13.
- Replace the covers and resume operation. There should be no need to recalibrate the electronic module.

6.2. Replacing or Installing an Isolation Valve

The VFM 3100 does not need to be removed from the pipeline to replace the isolation valve. However, the pipeline must be shut down and emptied before loosening the mounting bolts.

- If the VFM 3100 is wired with rigid conduit, it may be necessary to disconnect the input wiring and conduit connections.
- Remove the bolts holding the connector and the valve body.
- Remove and discard old gasket and flow dam. Install a new gasket and flow dam on the lower section of the valve body and assemble the valve into the VFM 3100 body. Refer to Figure 38 or Figure 39. These are the same gaskets and flow dams used with sensors. For standard range valves, use gasket L0121DT and flow dam L0112KT. For extended range valves, use gasket K0146HL and flow dam K0146HK.
- Install the four bolts on the bottom flange and tighten, using the procedure starting on page 38.

- Install a new gasket and flow dam on the sensor. Hold the sensor, mechanical connector, and housing together and carefully slide the sensor into the top of the valve body.
- Install the four bolts on the top flange and tighten, using the procedure starting on page 38.

NOTE: The gasket must be uniformly sealed and the bolts properly tightened on both the mechanical connector and valve body to assure a leak-tight seal. Failure to follow these steps could result in personal injury due to gasket leakage.

- Reconnect the conduit and external wiring. Refer to instruction starting on page 13.
- Replace the covers and resume operation.

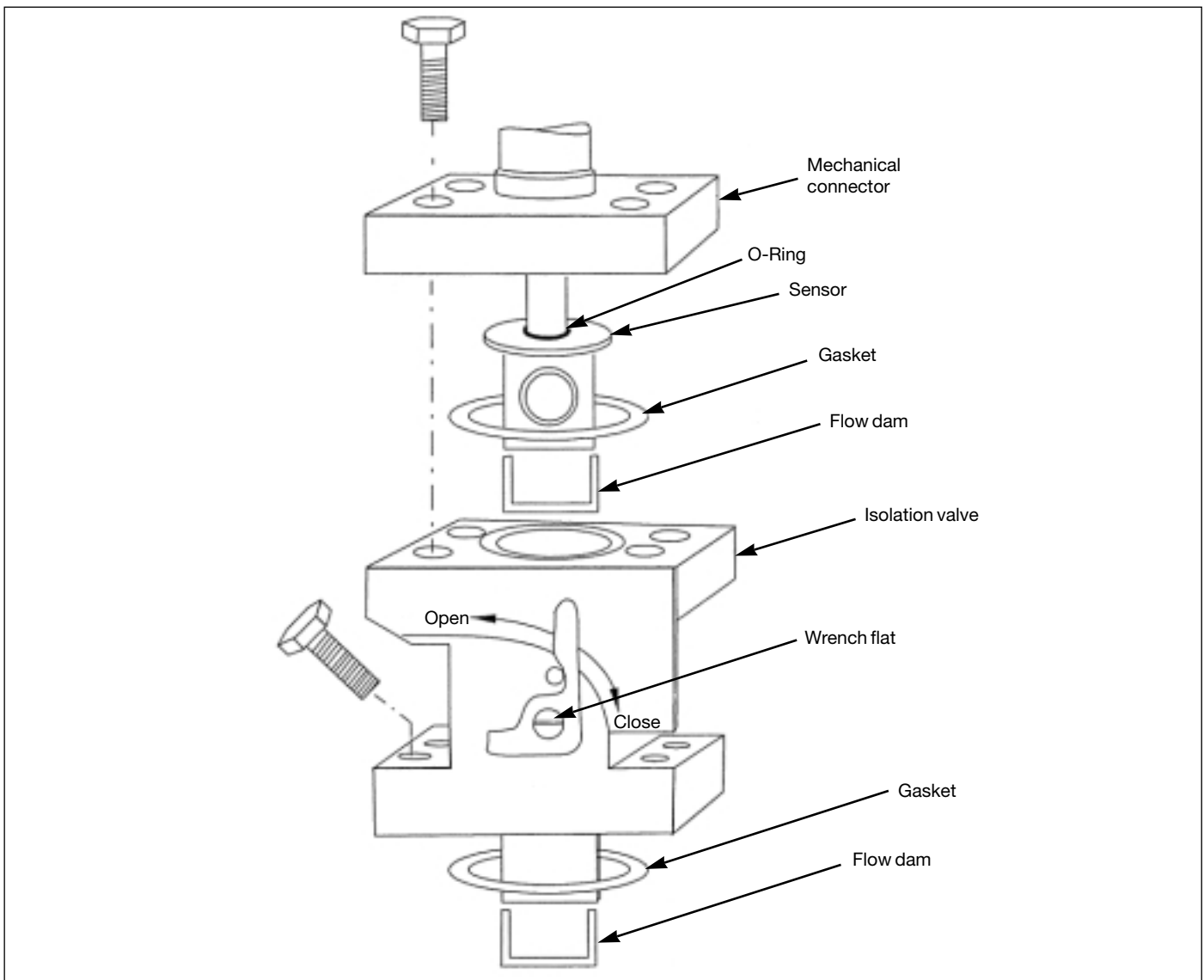

Figure 38. Isolation Valve

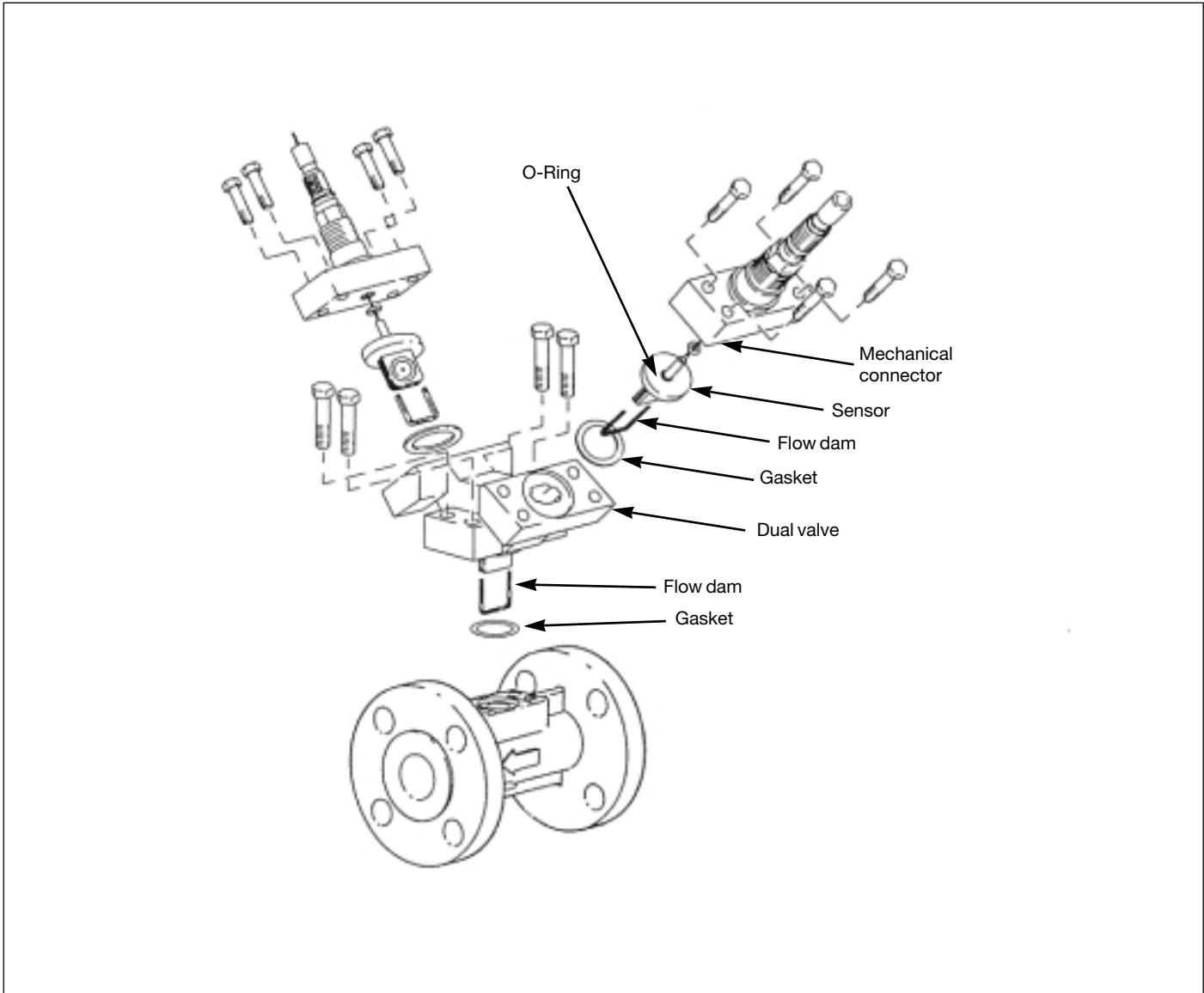

Figure 39. Dual Manifold

7. HART Configuration Instructions

7.1. Introduction

Generic instructions regarding the installation and operation of the HART Communicator can be found in the HART Communicator Product Manual.

7.2. HART Menu Structure

The on-line menu structure for the HART Communicator is shown in Figure 40. Key sequences for rapidly accessing given functions or parameters are shown in Figure 41.

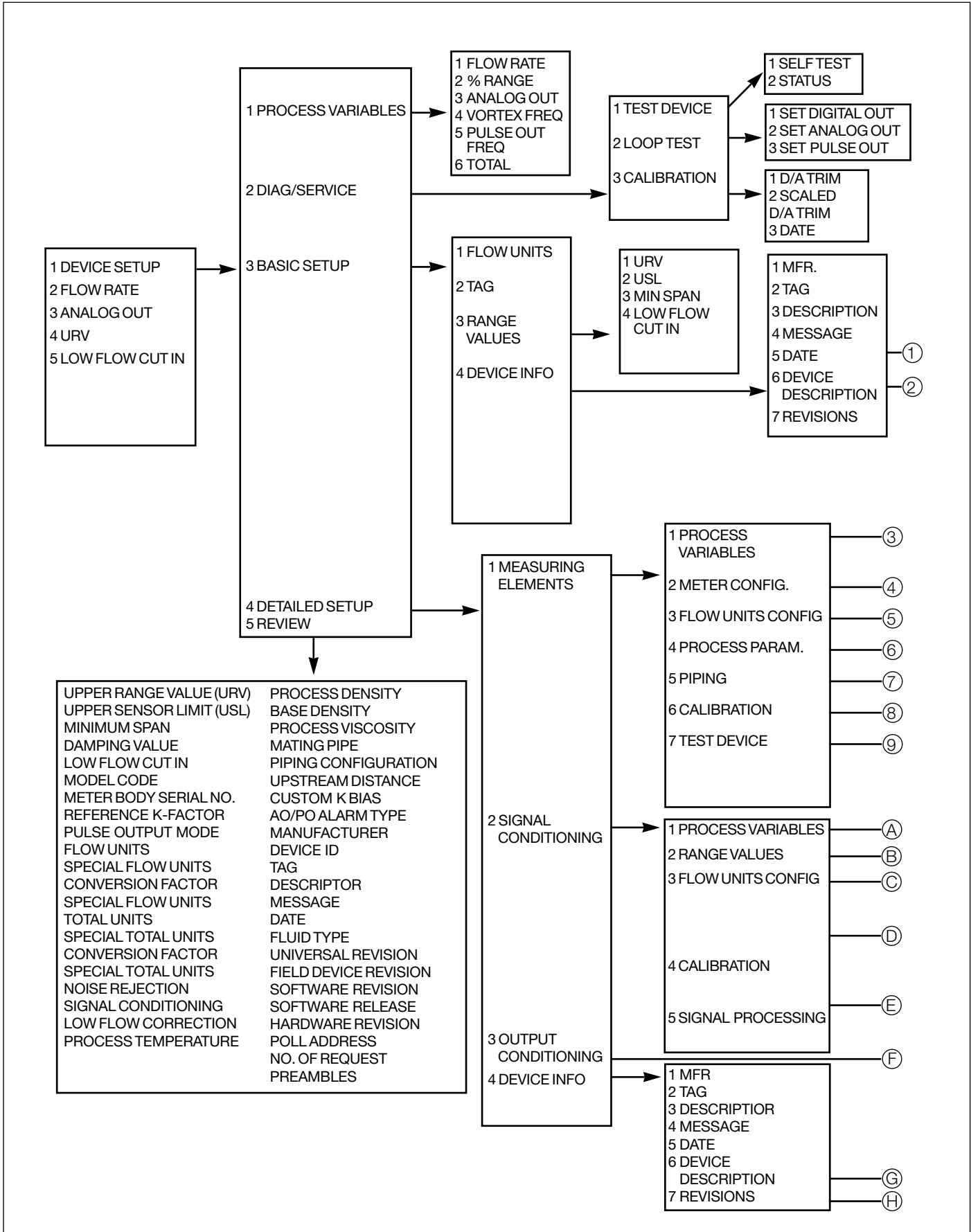

Figure 40. HART On-Line Menu Structure – Part 1 of 2

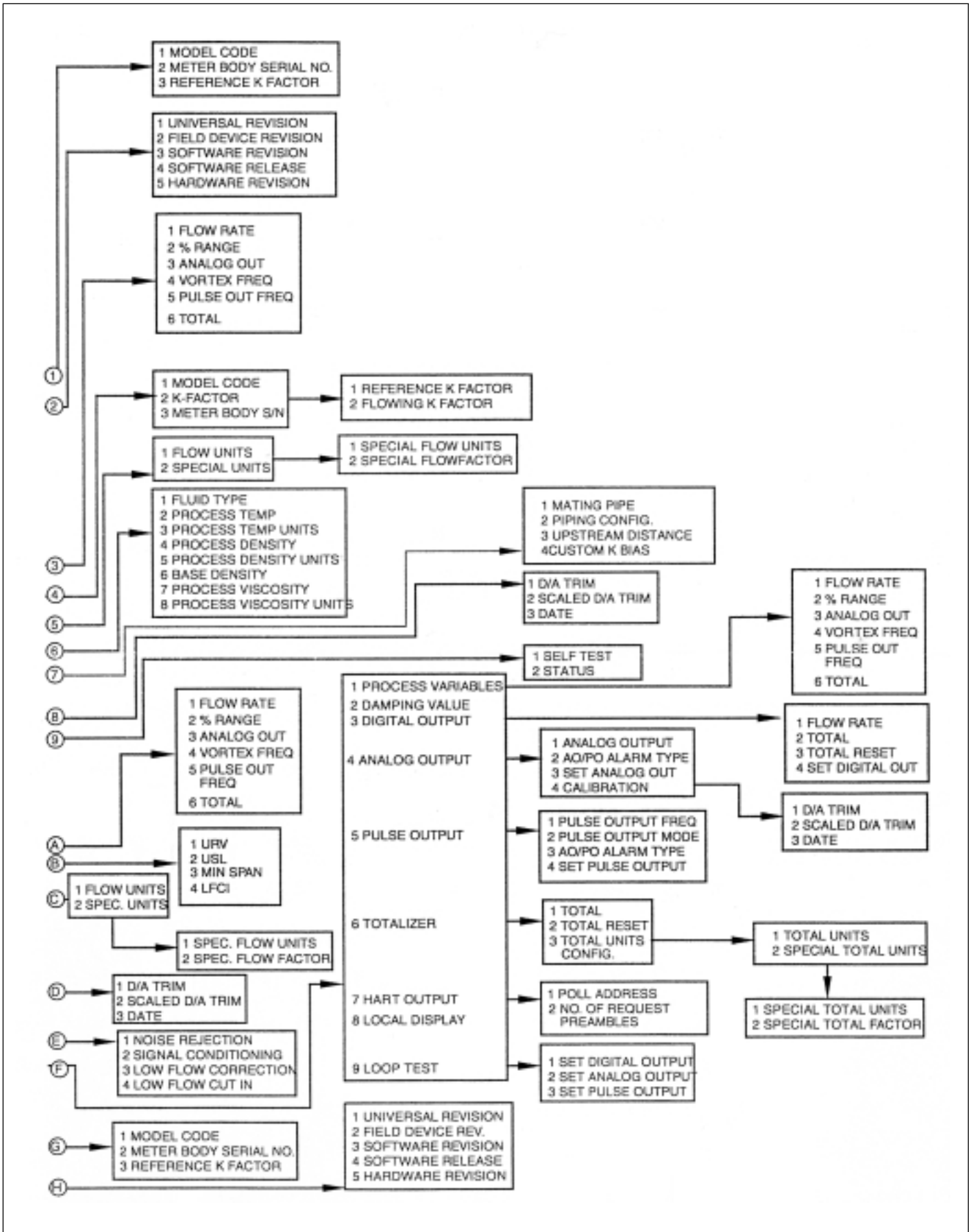

Figure 40. HART On-Line Menu Structure – Part 2 of 2

FUNCTION/VARIABLE	KEY SEQUENCE
Analog Output	3
AO/PO Alarm Type	1, 4, 3, 4, 2
Auto Low Flow Cut-In	1,3,3,4
D/A Trim	1,2,3,1
Damping Value	1,4,3,2
Date	1,2, 3, 2
Density, Base	1,4,1,4,6
Density, Process	1,4,1,4,4
Descriptor	1,3,4,3
Fluid Type	1,4,1,4,1
Flow Rate	2
Flow Rate (% of range)	1,1,2
K-Factor, Reference	1,3,4,6,3
K-Factor, Flowing	1,4,1,2,2,2
K-Factor Bias, Custom	1,4,1,5,4
Local Display	1,4,3,8
Loop Test	1,2,2
Low Flow Correction	1,4,2,5,3
Low Flow Cut-In	1, 3, 3, 4
Manufacturer	1,3,4,1
Message	1,3,4,4
Meter Body Serial Number	1,3,4,6,2
Minimum Span	1,3,3,3
Model Code	1,3,4,6,1
Noise Rejection	1,4,2,5,1
Number of Req. Preambles	1,4,3,7,2
Piping	1,4,1,5
Poll Address	1,4,3,7,1
Process Parameters	1,4,1,4
Process Variables	1,1
Pulse Output Frequency	1,1,5
Pulse Output Mode	1,4,3,5,2
Ranges Values	1,3,3
Review	1,5
Revisions	1,3,4,7
Scaled D/A Trim	1,2,3,2
Self Test	1,2,1,1
Signal Conditioning	1,4,2,5,2
Special Units, Flow	1,4,1,3,2
Special Units, Total	1,4,3,6,3, 2
Status	1,2,1,2
Tag	1,3,2
Temperature, Process	1,4,1,4,2
Total	1,1,6
Total Reset	1,4,3,6,2
Units, Flow	1,3,1
Units, Total	1,4,3,6,3,1
Upper Range Value (URV)	1, 3, 3, 1
Upper Sensor Limit (USL)	1,3,3,2
Viscosity, Process	1,4,1,4,7
Vortex Frequency	1,1,4

Figure 41. Fast-Key Function/Variable Chart

8. Local Configuration Instructions VFM 3100

8.1. Introduction

Local configuration of the VFM 3100 is accomplished via four multi-function pushbuttons on the local keypad/display shown below. A functional overview of the Menu Tree is presented in Table 12.

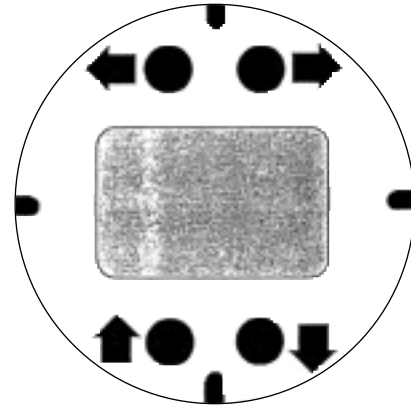

Table 12. Menu Tree Functional Overview

Level 1	Level 2	Function
MEASURE		Display Flowrate and Total
DISPLAY	OPTIONS PARAMS TAGS	Display Transmitter and Output Options Display Fluid and Application Parameters Display Flowtube and ID Parameters
CALIB	SHOW LFCI RESET TOTAL CAL 4 mA CAL 20 mA	Set Measurement Display Mode Set Low Flow Cut-In Set Total to Zero mA Calibration @ 4 mA mA calibration @ 20 mA
TEST	DIAG SET DIG SET MA SET HZ SELFST XMTTEMP	Display Status Set Digital Output for Loop Calibration Set 4-20 mA Output for Loop Calibration Set Scaled Pulse Output for Loop Calibration Activate Transmitter Self-Test Display Transmitter Temperature
CONFIG	OPTIONS OUTPUT FLUID UNITS BIAS TAGS NEWTUBE PASSWD	Select Transmitter Options Select Output Option Enter Fluid Parameters Enter Units, URV, and Damping Enter Application Parameter Enter Identification Parameters Enter Flowtube Parameters Change Passwords

8.2. Using the Local Configurator

8.2.1. Measurements (MEASURE)

The system starts up displaying the measured Flowrate (FLOW), the Total (TOTAL), or the Flow and Total (BOTH), in an alternating fashion, depending on the selection made in the Calibrate/Show menu.

8.2.2. Display Bar Indicator

The analog bar indicator at the top of the display indicates the flow measurement, as a percentage of the upper range value.

NOTE: If the flow measurement is out-of-range, the bar indicator will blink. If the transmitter is off-line, the middle four bars of the bar indicator will blink.

In TEST/SET DIG, the bar indicator continues to display the flow measurement. However, in TEST/SET MA, it displays the percentage of span set.

8.2.3. Moving inside the Menu System

Pressing ESC will stop displaying measurements, and show the first menu item, DISPLAY. From here, the four buttons allow the user to move around the menu tree, as indicated by the arrows. Press the down arrow repeatedly; the menu display will cycle through each of the top level (Level 1) menu items. Refer to the menu structure diagram on the following pages as you move around

NOTE: Each menu item has its level (1 - 4) displayed at the beginning of the top line.

The four buttons also allow the user to move up and down the pick-lists, as indicated by the arrows. Also, pressing ESC moves one from the current level to the next higher level. Pressing ESC within the top level menu returns the user to the MEASURE block.

8.2.4. Viewing Data (DISPLAY)

The OPTIONS, PARAMS, and TAGS sub menus are all read only. You may move around in them, but not alter any data.

In the PARAMS menu, the display alternates for all menu items between the parameter name and value/units (This is also the case when viewing the Transmitter Temperature in TEST/XMTTEMP). Go to PARAMS/URV; note that the "URV" and value/units alternate.

In the TAGS menu, the alphanumeric strings may be longer than the number of displayed characters. To shift the hidden characters into view, press the right or left arrow buttons. Go to TAGS/MODEL, and press the right arrow key several times. The MODEL string will scroll to the left, allowing you to view the hidden characters. To exit this menu item, either press the up or down arrows, or press ESC repeatedly until the string scrolls back to its original position.

8.2.5. Answering a Question

There are several places in the menu tree where a question will be displayed, such as "LOOP IN MANUAL?", mentioned below in "Entering the Password." To answer 'Yes', press ENTER, if 'No', press ESC.

8.2.6. Entering the Password

The CALIB, TEST and CONFIG sub menus require a password (a 4-character alphanumeric string). Changing the password will be addressed later. Select the CALIB, TEST or CONFIG menu from the top level, and press Enter at the PASSWD prompt. Two brackets surrounding 4 spaces ([____]) will appear on the second line of the display. The cursor, a flashing icon, appears at the first character.

To enter the password, use the up and down arrows to scroll through the list of acceptable characters. After selecting the desired character, press the right arrow to move to the next character. Continue this process until the password is complete. Pressing the right arrow once more moves the flashing cursor to the right bracket. Pressing Enter now completes the process. Prior to pressing Enter, the left and right arrows can be used to move back and forth to modify an incorrect selection.

If you enter an incorrect password, the display will indicate "SORRY" for 1 second, then return to the PASSWD prompt. After entering the correct password, the following message will appear, "LOOP IN MANUAL?". Press ENTER if 'Yes', ESC if 'No'. 'Yes' moves the user into the calibration, test, or configuration sub-menus. 'No' returns you to CALIB or CONFIG in the main menu.

The default password from the factory for TEST, CALIB, and CONFIG is [____], (four spaces). To enter it quickly, press the right arrow 5 times.

8.2.7. Activating an Edit, Pick-List or User Function Menu Block

To open a menu block that allows the user to edit or select data or to perform a function, such as RESET TOTAL, move to the menu block and press the Right arrow.

8.2.8. Editing Numbers and Strings

Editing any number or string in the menu system is done in the same way as entering the password above. The up and down arrows scroll through a list of acceptable characters for the current position.

The right arrow moves the cursor to the right; ENTER accepts the change at the end. The left arrow moves the cursor to the left; ESC cancels the change at the beginning.

There are three kinds of edit items: signed numbers, unsigned numbers, and strings.

Unsigned numbers cycle through the digits 0-9, and the decimal point, with the up and down arrows. For example try changing the CONFIG/FLUID/DENSITY item to 8.200.

When you enter a decimal point in any position, and there is already a decimal point to the left of the cursor, the new decimal point overrides the old one. Change the DENSITY from 8.200 to 82.00 by first selecting the decimal point to the right of the 2. Notice what happens when you enter the second decimal point (i.e., press the Right arrow).

Signed numbers always have a + or - sign at the beginning. The + can only be changed to -, and vice versa.

Finally, characters in strings may be changed to any valid character. The sequence of characters you can get for strings by pressing the up and down arrows is: space, A-Z, a-z, 0-9, period, dash, slash. Go to CONFIG/TAGS/GEOLC and change it. Note that the entire data field is not visible at once. To enter the change you must still press ENTER from the right side of the data field, after scrolling to the right side with the right arrow.

8.2.9. Picking from a List

Pick-List items allow the user to choose a value from a transmitter supplied list of alternatives. Go to CONFIG/FLOW/UNITS, and press ENTER. The entire bottom line of the display flashes. If you press the up or down arrows, the display will show the next or previous choice from its list. Pressing ENTER will accept the change; pressing ESC will return the previous value.

8.2.10. mA Calibration (TEST/CAL 4 mA or CAL 20 mA)

When opening the CAL 4 mA or CAL 20 mA menu block, 0.5+/- will be displayed. To enter this value, i.e., to change the mA output of the transmitter, press the up arrow to add 0.5 mA, or down arrow to subtract 0.5 mA. By pressing the right arrow values of 0.05 and 0.005 can be selected, and entered by the up and down arrows. The display will not change when entering the selected value. To have the new calibration accepted by the transmitter, move with the right arrow to the end of the data field. To restore the original calibration, move with the left arrow to the beginning.

8.2.11. Transmitter Status

If there is a transmitter failure, an error message will appear when entering the TEST menu.

8.2.12. Changing the Password

Changing the password is done in CONFIG/PASSWD. Before changing the password, a prompt will appear requesting the old password to be entered. CALIB and TEST share the same password. A different password can be used for CALIB.

8.3. Local Configurator Menu Tree

8.3.1. Reading the Menu Tree

The menu tree used to carry out local configuration is shown on the following pages. Each block on the menu diagram signifies a menu item. The text in the block indicates the title of the item, and any data displayed. The text under each block indicates the type of menu item. There are five item types: Branch, Edit----, PickList, Group, and UserFunc.

- Branch items do not display or edit data, but simply move you to another menu item depending on which key is pressed.
- Edit ---- items* display a numeric (real or integer) or string value, which may be edited.

- PickList items* display one of several alternatives, which may be selected. PickList items have the choices to pick from enclosed in a dashed box to the right of the item.
- Group items display, alternately, a parameter name and its value/units. You are not allowed to change them at this point in the menu tree.
- UserFunc items do not display or edit data, rather they allow a built-in function to be activated.
- * Edit---- and PickList items marked R/O (read only) will display the associated data, but you will be unable to change them at this point in the menu tree.

8.4. Local Configurator Menu (1 through 8)

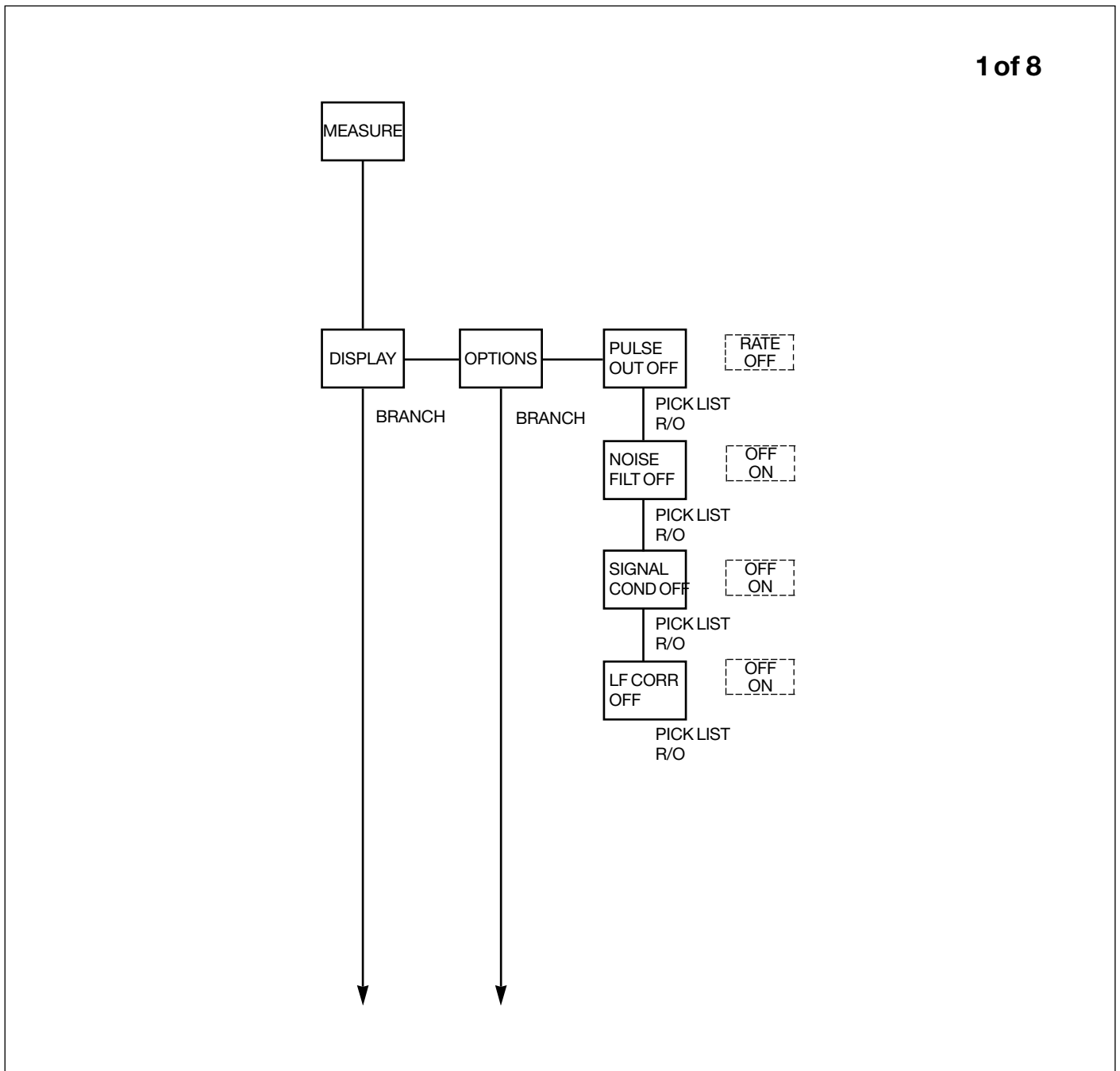
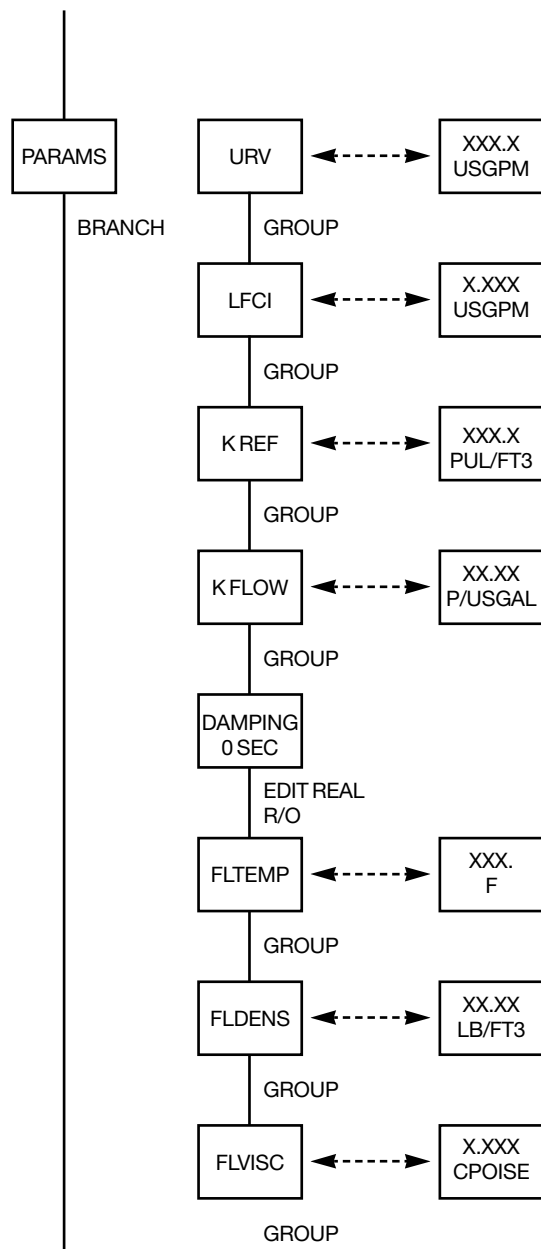
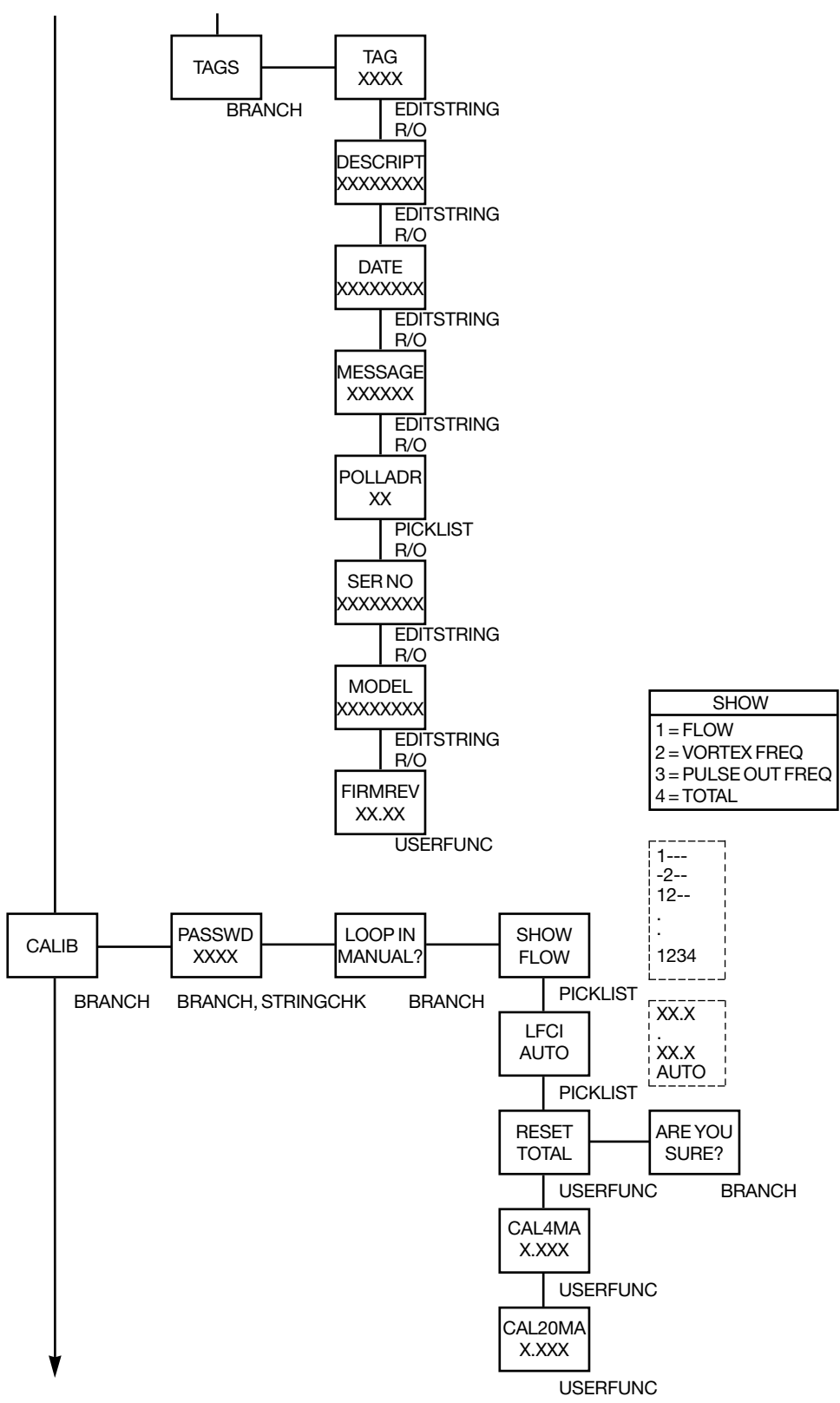
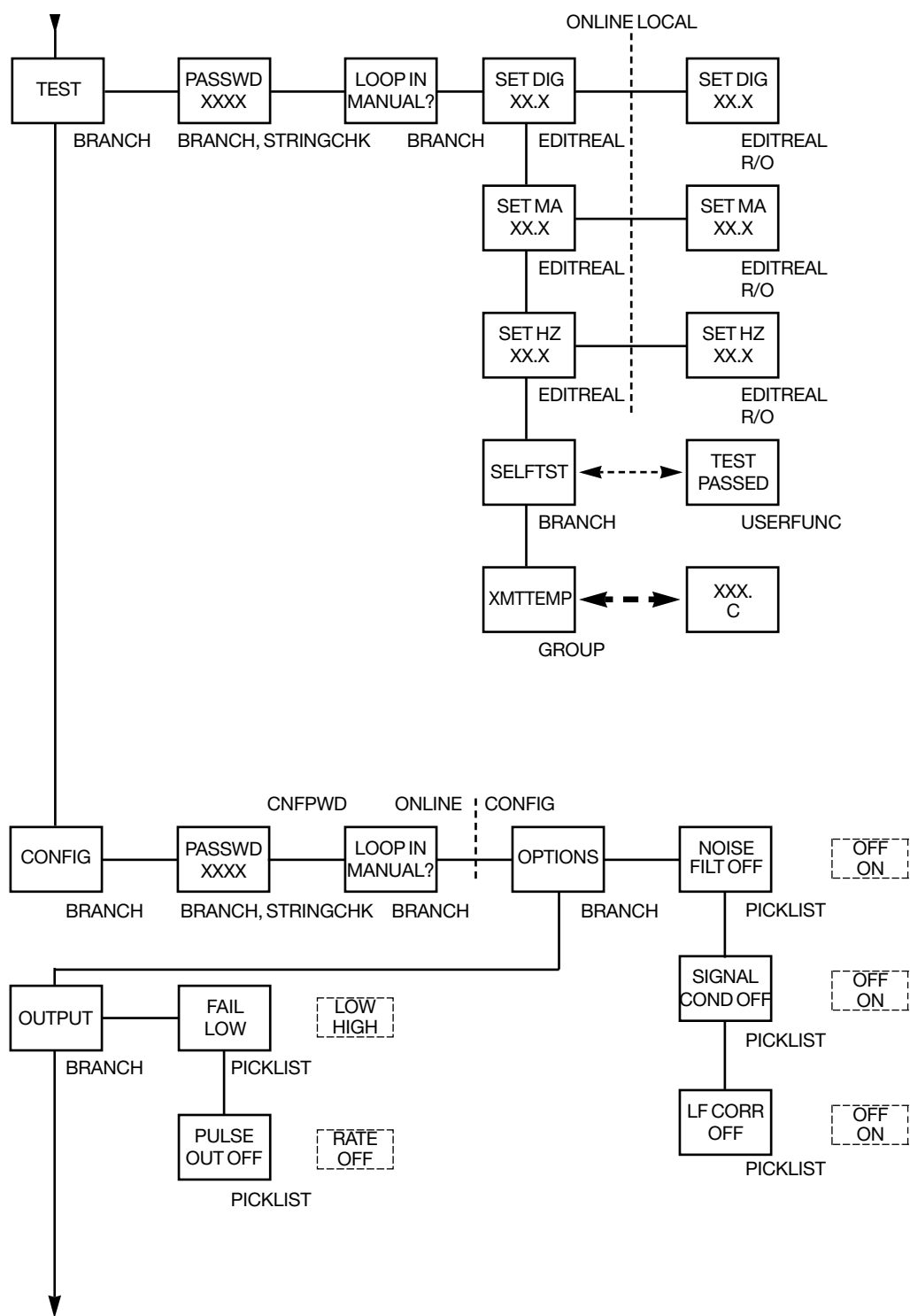
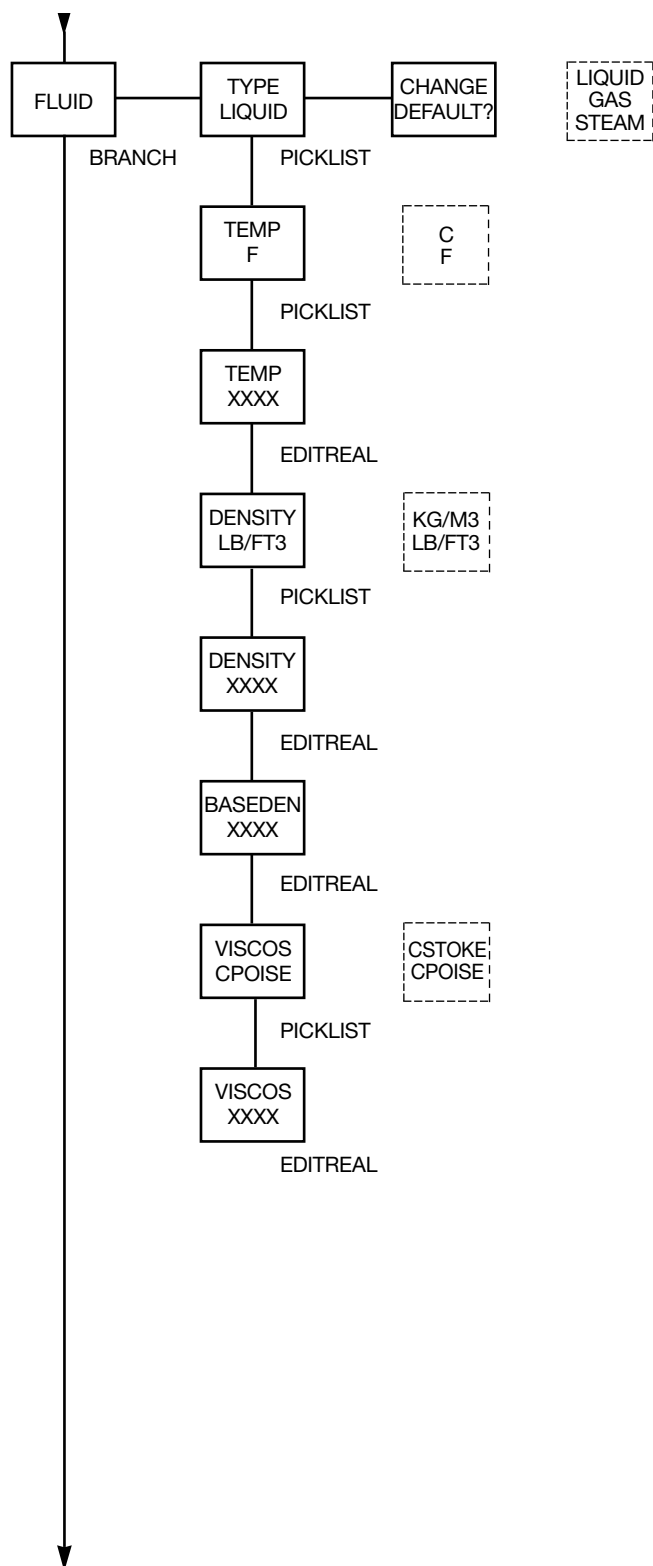

Figure 42.









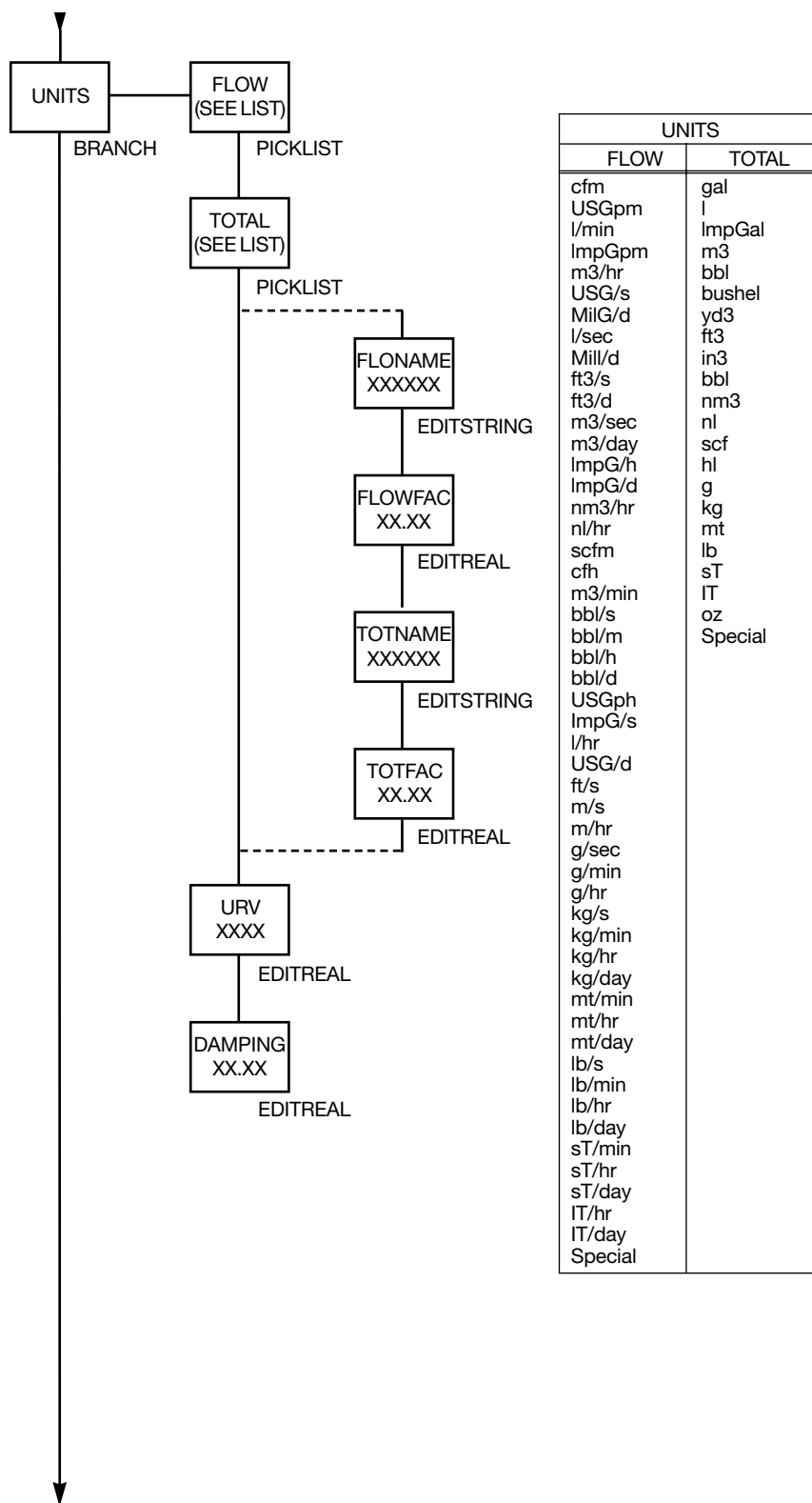

UNITS	
FLOW	TOTAL
cfm	gal
USGpm	l
l/min	ImpGal
ImpGpm	m3
m3/hr	bbl
USG/s	bushel
Mill/d	yd3
l/sec	ft3
Mill/d	in3
ft3/s	bbl
ft3/d	nm3
m3/sec	nl
m3/day	scf
ImpG/h	hl
ImpG/d	g
nm3/hr	kg
nl/hr	mt
scfm	lb
cfh	sT
m3/min	IT
bbl/s	oz
bbl/m	Special
bbl/h	
bbl/d	
USGph	
ImpG/s	
l/hr	
USG/d	
ft/s	
m/s	
m/hr	
g/sec	
g/min	
g/hr	
kg/s	
kg/min	
kg/hr	
kg/day	
mt/min	
mt/hr	
mt/day	
lb/s	
lb/min	
lb/hr	
lb/day	
sT/min	
sT/hr	
sT/day	
IT/hr	
IT/day	
Special	

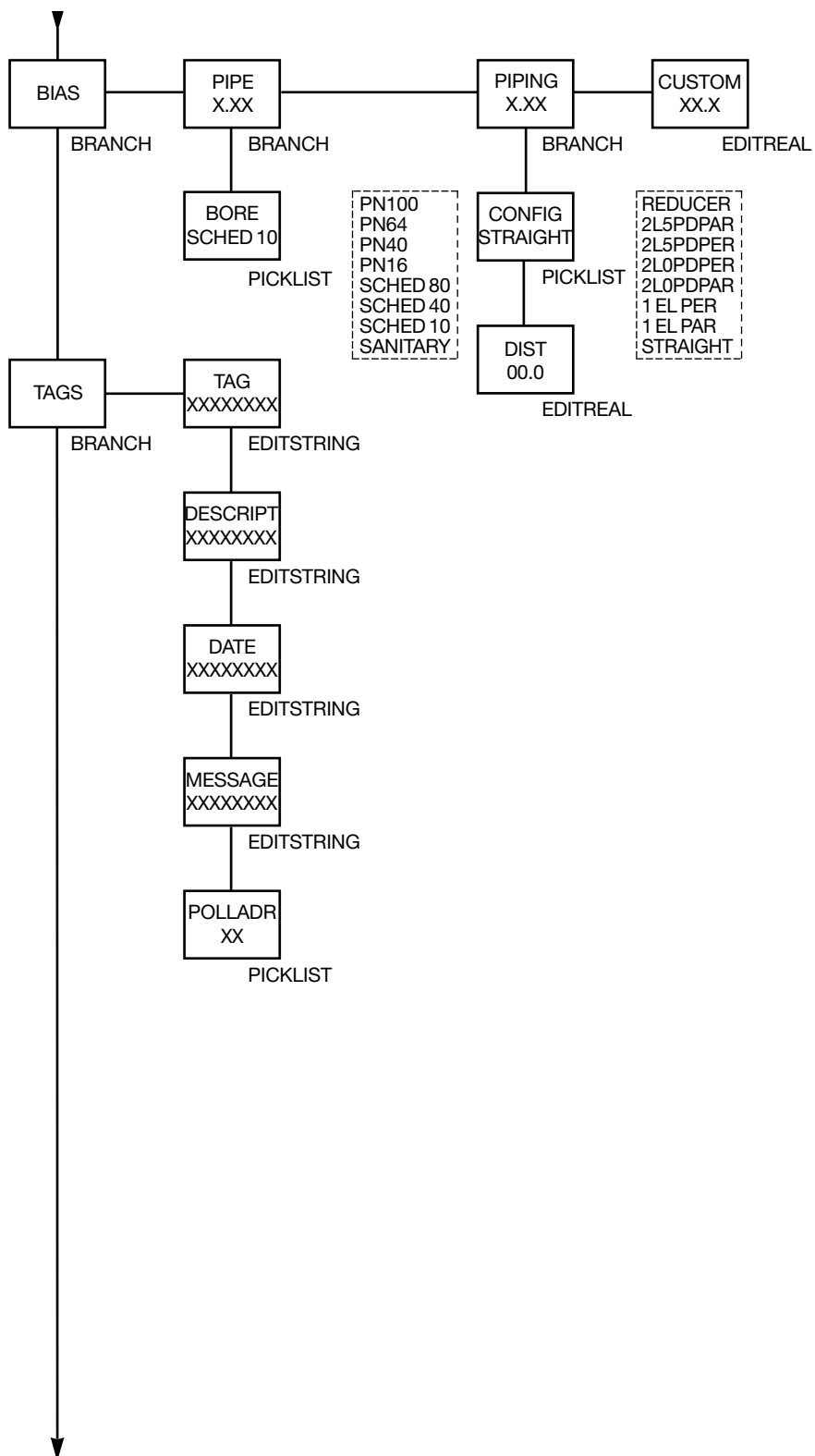

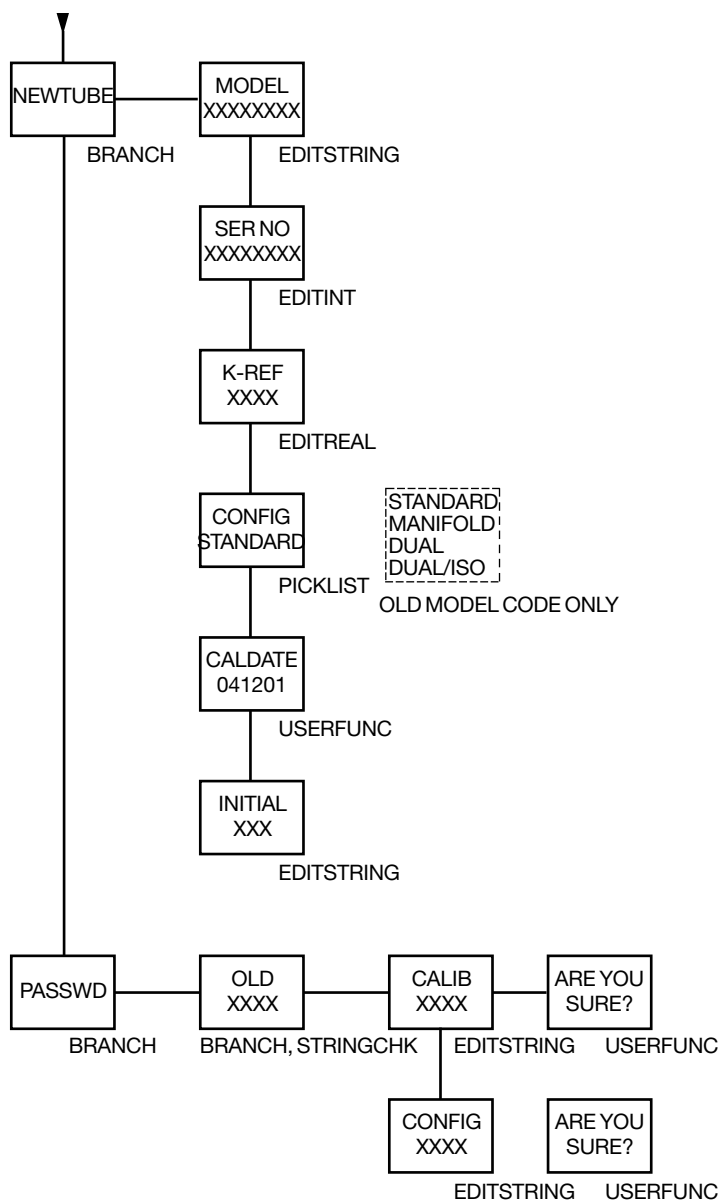

9. Configuration Database

This appendix defines and describes the parameters in the configuration database shown in the following table.

Table 13. Configuration Database

<p>Flowtube Parameters</p> <ul style="list-style-type: none"> • Model Code • Meter Body Serial Number • Reference K-Factor 	<p>Process Fluid Parameters</p> <ul style="list-style-type: none"> • Fluid Type • Process Temperature • Process Density • Base Density • Process Viscosity
<p>Identification Parameters</p> <ul style="list-style-type: none"> • Tag • Descriptor • Date • Message • Polling Address 	<p>Application Parameters</p> <ul style="list-style-type: none"> • Mating Pipe • Piping Configuration • Upstream Distance • Custom K-factor Bias • Upper Range Value
<p>Transmitter Options</p> <ul style="list-style-type: none"> • Flow Units • Total Units • Noise Rejection • Signal Conditioning • Low Flow Correction • Low Flow Cut-In 	<p>Output Options</p> <ul style="list-style-type: none"> • Damping Value • Pulse Output • AO/PO Alarm Type

In the following a number in braces {#} indicates the maximum string length for alphanumeric parameters.

9.1. Flowtube Parameters

- Model Code (MSCode) [alphanumeric entry, {16}]

This is a manufacturer defined quantity. It resides on the VFM 3100 tag and in the database if the electronics and flowtube are shipped as a unit.

Default: 'blank', if electronic module is shipped alone

- Meter Body Serial Number [alphanumeric entry, {16}]

This is a manufacturer defined quantity. It resides on the VFM 3100 tag and in the database, if the electronics and flowtube are shipped as a unit.

Default: 'blank', if electronic module is shipped alone

- Reference K-Factor [numeric entry]

This is the reference calibration factor. It is entered as a pure number. The value of the number is sufficient to define the proper units, i.e., pulses/ft³ or pulses/liter. It resides on the VFM 3100 tag and in the database, if the electronics and flowtube are shipped as a unit.

Default: 'blank' if electronic module is shipped alone

9.2. Identification Parameters

Tag [alphanumeric entry, {8}]

This is a user defined quantity.

Default: 'blank'

Descriptor [alphanumeric entry, {16}]

This is a user defined quantity.

Default: 'blank'

Date [numeric entry, {6}]

This is a user defined quantity. In the case of the HART Configurator the Date (XXXXXX) is expressed as MMDDYY, for the Local Configurator it is expressed as YYMMDD.

Default: HART = 051194, Local = 940511

Message [alphanumeric entry, {32}]

Default: 'blank'

Polling Address [numeric entry, {2}]

This is a user defined quantity. The HART protocol allows the connections of up to 15 HART devices on a single twisted pair of wires, or over leased telephone lines, a concept known as 'multidrop-ping'. In a multidrop installation, each transmitter is identified by a unique address (1-15) referred to as the polling address. In the multidrop mode, i.e., a non-zero polling address, the analog output of the transmitter is set to a fixed value of 4 mA. For a non-multidrop installation, i.e., a single transmitter loop, the polling address of the transmitter must be set to zero if the analog output is intended to indicate flow (4-20 mA).

Default: 0

9.3. Transmitter Options

Flow Units [Pick-List]

This selection defines the units for the measured flow rate. Selecting Special Units allows the user to define units not listed. The procedure for doing this is described in chapter 5.

Default: USgpm

Total Units [Pick-List]

This selection defines the units for the measured total rate. Selecting Special Units allows you to define units not listed. The procedure for doing this is described in chapter 5.

Default: USgal

Noise Rejection [On,Off]

This selection allows the user to turn off the adaptive noise rejection feature. When On, this feature improves VFM 3100 performance by rejecting process noise. Off would normally be selected only for troubleshooting the process.

Default: On

Signal Conditioning [On,Off]

This selection provides the user a means of turning off the low flow signal conditioning feature. When On, this feature improves VFM 3100 performance by reducing the adverse effects of process noise on the vortex signal. Off would normally be selected only for troubleshooting the process.

Low Flow Correction [On,Off]

This selection provides a means for turning on the low flow K-factor correction. When On, this feature corrects for the nonlinearity of the K-Factor that occurs at Reynolds Numbers below 20,000. The default for this parameter is Off to alert the user to the fact that actual values of the Process Density and Viscosity must be entered into the database to achieve improved accuracy.

Default: Off

Low Flow Cut-In [Pick-List]

The low flow cut-in parameter allows the user to set the level above which the VFM 3100 begins to measure flow, i.e., the lower range limit of the VFM 3100. This process can be carried out automatically if the flow is turned off. Otherwise, manual selection from the following pick-list of eight levels can be made:

AUTO, (L0), (L1), (L2), (L3), (L4), (L5), (L6), (L7)

For convenience, these levels are displayed as estimated flow rates in the selected flow units. The value of these flow rates depend on the specific application parameters.

Default: (L3)

9.4. Process Fluid Parameters

Fluid Type [Pick-List: Liquid, Gas, Steam]

Three options are available: Liquid, Gas, or Steam. Knowledge of the process fluid type is necessary for the automatic selection of default process fluid properties.

NOTE: *If a standard volume output is desired, the user is required to enter base density.*

Default: Liquid

Process Temperature [numeric entry for value; Pick-List for units: °F, °C]

This is the actual temperature at process conditions. It is needed to make the thermal expansion correction to the K-Factor.

Default: 70 °F or 20 °C (depending on units of Reference K-Factor)

Process Density [numeric entry for value; Pick-List for units: LB/FT³, KG/M³]

This is the actual density at process conditions. It is needed by the VFM 3100 to compute internally the lower and upper flow range limits. It is also needed to compute mass flow, if selected.

NOTE: *Enter density, not specific gravity.*

Default depends on selected fluid type and units of Reference K-Factor:

- *Liquid - 62.301 LB/FT³; 998.2 KG/M³*
- *Gas - 0.5858 LB/FT³; 9.546 KG/M³*
- *Steam - 0.2992 LB/FT³; 4.618 KG/M³*

Base Density [numeric entry]

This information is only applicable if output in standard volume is desired. Units are the same as those selected for the flowing density.

Default depends on selected fluid type and units of Reference K-Factor:

- *Liquid - 62.374 LB/FT³; 999.2 KG/M³*
- *Gas - 0.07634 LB/FT³; 1.293 KG/M³*
- *Steam - 0.03730 LB/FT³; 0.5977 KG/M³*

Process Viscosity [numeric entry of value; Pick-List for units: Absolute (CPOISE), Kinematic (CSTOKE)]

This is the actual viscosity at process conditions. It is required only if the Low Flow Correction is On.

Default depends on selected fluid type and units of Reference K-Factor:

- *Liquid - 0.9753 CPOISE or 1.002 CPOISE*
- *Gas - 0.0186 CPOISE or 0.0185 CPOISE*
- *Steam - 0.0150 CPOISE or 0.0149 CPOISE*

9.5. Application Parameters

Mating Pipe [Pipe Schedule Pick-List]

This menu selection allows the Reference K-factor to be corrected internally for piping bore mismatch upstream of the VFM 3100. The pick-list is as follows:

SCHED 10, SCHED 40, SCHED 80
PN 16, PN40, PN 64, PN 100
SANITARY

Default: SCHED 40 (corresponds to zero bias)

Piping Configuration [Pick-List]/
Upstream Distance [numeric entry]

These selections allow the Reference K-factor to be corrected automatically for upstream piping disturbances via a menu selection of the piping configuration and a numeric input of the upstream pipe length in pipe diameters (PD). The piping configuration pick-list is as follows

Configurator		Piping Description
HART	Local	
Straight	STRAIGHT	50 PD or more of straight pipe up-stream of VFM 3100
1 L paral to shed	1 EL PAR	Single, long radius, 90° elbow; vortex shedder parallel to plane of elbow
1 L perp to shed	1 EL PER	Single, long radius, 90° elbow; vortex shedder perpendicular plane of elbow
2 L cls paral shed	2L0PDPAR	Two elbows in series and in different planes; vortex shedder parallel to plane of closest elbow; elbows close coupled, i.e., no separation
2 L cls perp shed	2L0PDPER	Two elbows in series and in different planes; vortex shedder perpendicular to plane of closest elbow; elbows close coupled, i.e., no separation
2 L 5 dia paral	2L5PDPAR	Two elbows in series and in different planes; vortex shedder parallel to plane of closest elbow; elbows have 5 pipe diameter separation
2 L 5 dia perp	2L5PDPER	Two elbows in series and in different planes; vortex shedder perpendicular to plane of closest elbow; elbows have 5 pipe diameter separation
Reducer	REDUCER	Reducer with either a 3:2 or 4:3 reduction

Default: STRAIGHT (corresponds to zero bias) and 30.0 PD

Custom K-Factor Bias [numeric entry in percent]

This allows entry of a user established bias in percent to correct the Flowing K-Factor. This bias correction is in addition to those addressed above, i.e., Mating Pipe and Piping Configuration/Upstream Distance.

Default: 0.0

Upper Range Value [numeric entry]

This allows the user to set the upper range operating limit of the VFM 3100. In the case of 4 to 20 mA output, it also establishes the flow value corresponding to 20 mA; and in the case of scaled pulse output, the flow value corresponding to 100 Hz.

Default: Upper Range Flow Limit

9.6. Output Options

Damping Value [numeric entry]

This feature allows the flow rate output to be smoothed.

Default: 2 seconds

Scaled Pulse Output [Pick-List: Off, Rate]

The Scaled Pulse Output, a contact closure, provides a frequency output that is linearly related to the flowrate, the upper range value being set to 100 Hz. For example, for a flow range to 0 to 500 USgpm, the frequency of the scaled pulse output goes from 0 to 100 Hz.

Default: Off

AO/PO Alarm Type [Pick-List: Lo, Hi]

This allows the user to pick the desired output that the instrument will go to in the event of a transmitter failure:

Digital	Not Applicable
4 to 20 mA	Downscale (3.75 mA)
	Upscale (20.38 mA)
Scaled Pulse	Downscale (Off)
	Upscale (125 Hz)

Default: Upscale