



OPTIFLEX 2200 C/F Quick Start

Guided Radar (TDR) Level Transmitter for storage and process applications

1	Safety instructions	4
<hr/>		
2	Installation	5
<hr/>		
2.1	Intended use	5
2.2	Scope of delivery.....	6
2.3	Visual Check	7
2.4	Storage	8
2.5	Transport	9
2.6	Pre-installation requirements	9
2.7	How to prepare the tank before you install the device	10
2.7.1	Pressure and temperature ranges.....	10
2.7.2	General information for nozzles.....	13
2.7.3	Installation requirements for concrete roofs.....	15
2.8	Installation recommendations for liquids.....	16
2.8.1	General requirements	16
2.8.2	Installation in standpipes (stilling wells and bypass chambers)	17
2.9	Installation recommendations for solids	18
2.9.1	Nozzles on conical silos.....	18
2.9.2	Traction loads on the probe.....	19
2.10	How to install the device on the tank	20
2.10.1	How to assemble the single rod probe (single-piece probe)	20
2.10.2	How to assemble the single rod probe (segmented probe)	24
2.10.3	How to assemble the segmented coaxial probe	27
2.10.4	How to install a device with a flange connection.....	30
2.10.5	How to install a device with a threaded connection	31
2.10.6	How to install a device with a hygienic connection	32
2.10.7	How to install a cable probe in the tank	34
2.10.8	How to turn or remove the signal converter	35
2.10.9	Recommendations for pits and tanks made of non-conductive materials.....	36
2.10.10	Wall support for the remote version	37
2.10.11	How to attach the weather protection to the device.....	37
2.10.12	How to open the weather protection	40
2.11	Electromagnetic compatibility	41
<hr/>		
3	Electrical connections	42
<hr/>		
3.1	Electrical installation: 2-wire, loop-powered	42
3.1.1	Compact version	42
3.1.2	Remote version	44
3.2	Non-Ex devices	45
3.3	Devices for hazardous locations	45
3.4	Minimum power supply voltage	46
3.5	Protection category	47
3.6	Networks	48
3.6.1	General information.....	48
3.6.2	Point-to-point networks	48
3.6.3	Multi-drop networks	49
3.6.4	Fieldbus networks.....	50

4 Operation	52
4.1 General notes	52
4.2 Digital display screen	52
4.2.1 Local display screen layout	52
4.2.2 Functions of keypad buttons.....	52
4.3 Commissioning	53
4.4 Probe length calculation	55
4.5 Snapshot	57
5 Notes	59

Warnings and symbols used**DANGER!**

This information refers to the immediate danger when working with electricity.

**DANGER!**

These warnings must be observed without fail. Even partial disregard of this warning can lead to serious health problems and even death. There is also the risk of seriously damaging the device or parts of the operator's plant.

**WARNING!**

Disregarding this safety warning, even if only in part, poses the risk of serious health problems. There is also the risk of damaging the device or parts of the operator's plant.

**CAUTION!**

Disregarding these instructions can result in damage to the device or to parts of the operator's plant.

**INFORMATION!**

These instructions contain important information for the handling of the device.

**HANDLING**

- This symbol designates all instructions for actions to be carried out by the operator in the specified sequence.

RESULT

This symbol refers to all important consequences of the previous actions.

Safety instructions for the operator**CAUTION!**

Installation, assembly, start-up and maintenance may only be performed by appropriately trained personnel. The regional occupational health and safety directives must always be observed.

**LEGAL NOTICE!**

The responsibility as to the suitability and intended use of this device rests solely with the user. The supplier assumes no responsibility in the event of improper use by the customer. Improper installation and operation may lead to loss of warranty. In addition, the "Terms and Conditions of Sale" apply which form the basis of the purchase contract.

**INFORMATION!**

- *Further information can be found in the handbook and on the data sheet. These documents can be downloaded from the website (Download Center).*
- *If you need to return the device to the manufacturer or supplier, please fill out the device return form and send it with the device. Unfortunately, the manufacturer cannot repair or inspect the device without the completed form. The form can be found in the handbook or downloaded from the website. Click on the "Service" tab on one of the web pages and read the instructions.*

2.1 Intended use

**CAUTION!**

Responsibility for the use of the measuring devices with regard to suitability, intended use and corrosion resistance of the used materials against the measured fluid lies solely with the operator.

**INFORMATION!**

The manufacturer is not liable for any damage resulting from improper use or use for other than the intended purpose.

This TDR level transmitter measures distance, level, mass and volume of liquids, pastes, slurries, granulates and powders.

It can be installed on tanks, silos and open pits.

2.2 Scope of delivery



INFORMATION!

Do a check of the packing list to make sure that you have all the elements given in the order.

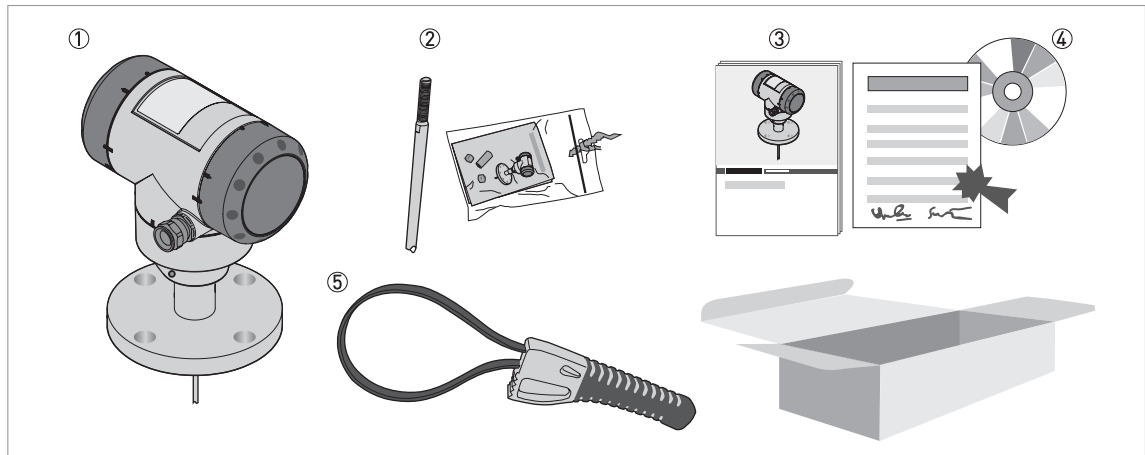

Figure 2-1: Scope of delivery

- ① Signal converter and probe.
- ② Probe segments. For the assembly procedure of the single rod probe, refer to the instructions that are supplied with the device. If a single rod or coaxial probe is attached and you ordered the "segmented probe" option, only part of the probe is attached to the device. For the assembly procedure of the segmented single rod probe, refer to the instructions that are supplied with the device. For the assembly procedure of the segmented coaxial probe, refer to the instructions that are supplied with the device.
- ③ Quick Start
- ④ DVD-ROM. This contains the Handbook, the Quick Start and the Technical Data Sheet.
- ⑤ Strap wrench



INFORMATION!

No training required!



CAUTION!

Make sure that the length of the probe is correct.

2.3 Visual Check



INFORMATION!

Inspect the packaging carefully for damages or signs of rough handling. Report damage to the carrier and to the local office of the manufacturer.

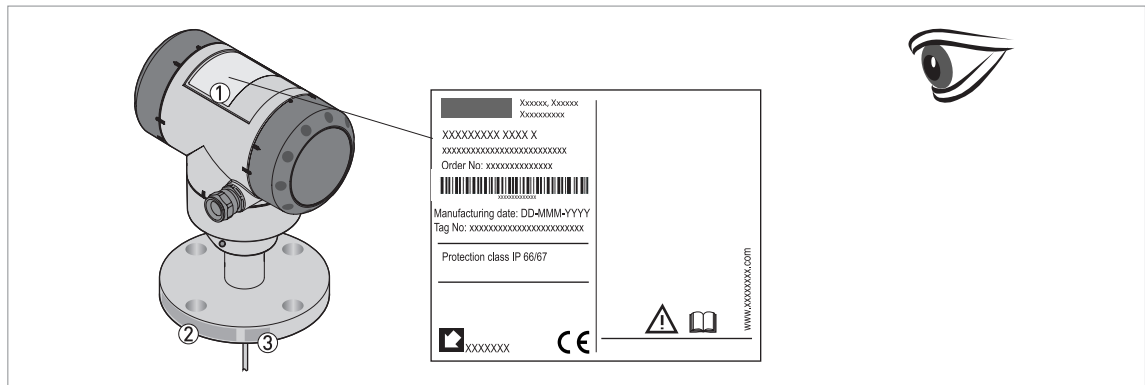

Figure 2-2: Visual check

- ① Device nameplate (for more data, refer to the handbook)
- ② Process connection data (size and pressure rating, material reference and heat number)
- ③ Gasket material data – refer to the illustration that follows

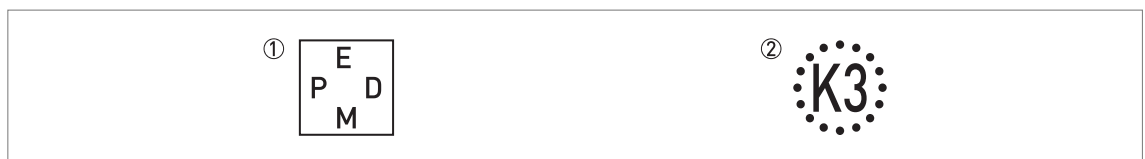

Figure 2-3: Symbols for the supplied gasket material (on the side of the process connection)

- ① EPDM
- ② Kalrez® 6375

If the device is supplied with an FKM/FPM gasket, there is no symbol on the side of the process connection.



INFORMATION!

Look at the device nameplate to ensure that the device is delivered according to your order. Check for the correct supply voltage printed on the nameplate.

2.4 Storage

**WARNING!**

Do not keep the device in a vertical position. This will damage the probe and the device will not measure correctly.

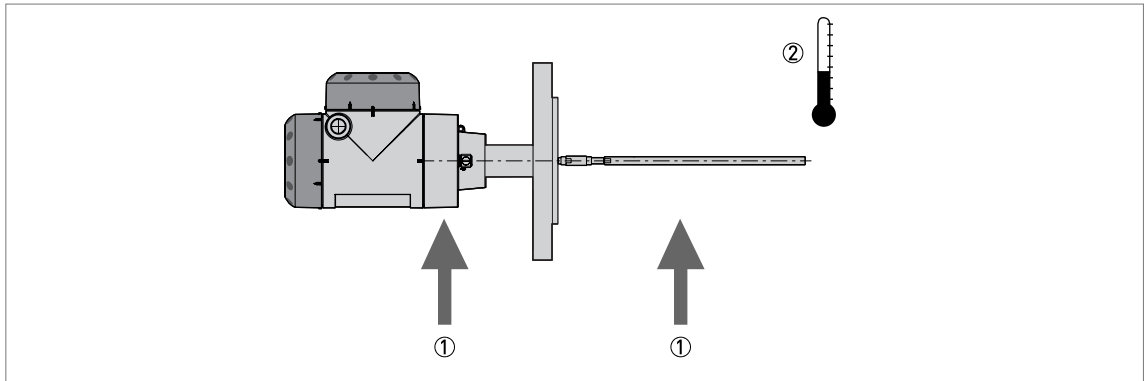

Figure 2-4: Storage conditions

- ① Do not bend rod and coaxial probes – support here
- ② Storage temperature range: -50...+85°C / -60...+185°F (min. -40°C / -40°F for devices with the integrated LCD display option)

- Store the device in a dry and dust-free location.
- Store the device in its original packing.

2.5 Transport

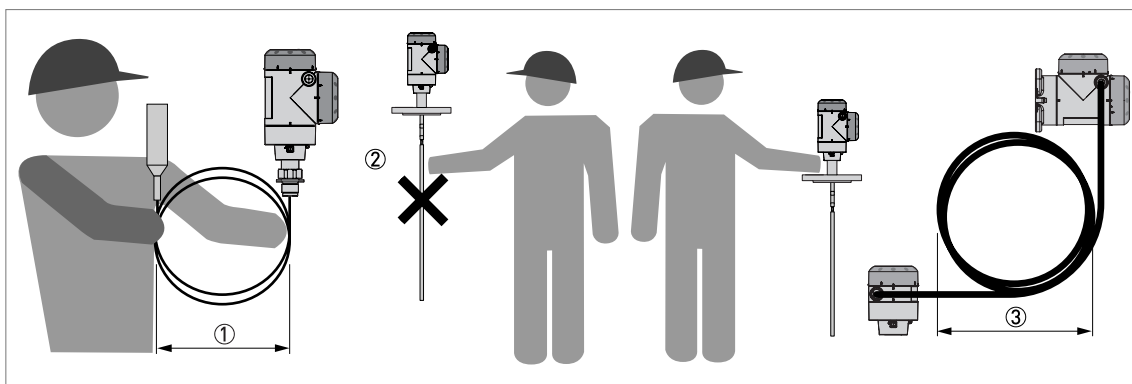

Figure 2-5: How to hold the device

- ① Wind cable probes greater than 400 mm / 16" in diameter.
- ② Do not hold the probe when you lift the device.
- ③ Do not wind the electrical cable less than 330 mm / 13" in diameter.



WARNING!

If you do not lift the device carefully, you can cause damage to the probe.

2.6 Pre-installation requirements



INFORMATION!

Obey the precautions that follow to make sure that the device is correctly installed.

- Make sure that there is sufficient space on all sides.
- Protect the signal converter from direct sunlight. If necessary, install the weather protection accessory.
- Do not subject the signal converter to heavy vibrations.

2.7 How to prepare the tank before you install the device



CAUTION!

To avoid measuring errors and device malfunction, obey these precautions.

2.7.1 Pressure and temperature ranges

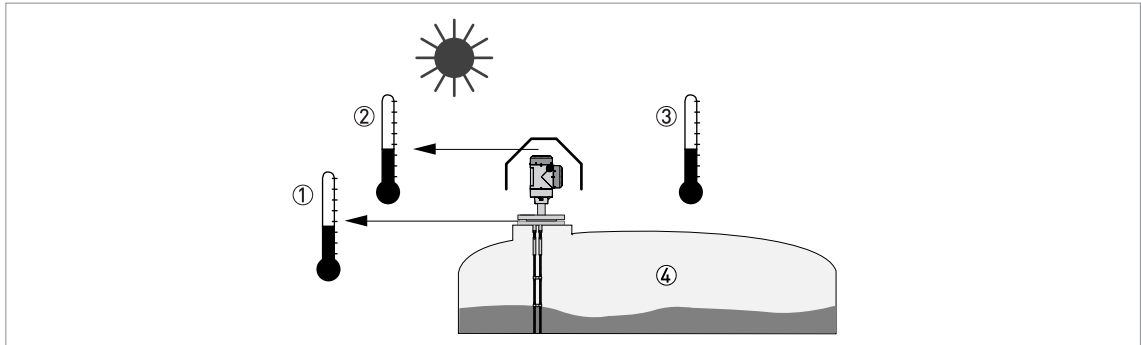

Figure 2-6: Pressure and temperature ranges

- ① Temperature at the process connection
The temperature at the process connection must stay in the temperature range of the gasket material unless the device is a High-Temperature version. Refer to the table "Permitted temperature ranges for gaskets" that follows and to "Technical data" in the handbook.
Devices with Hazardous Location approvals: see supplementary instructions
- ② Ambient temperature for operation of the display
-20...+60°C / -4...+140°F
If the ambient temperature is not between these limits, the display screen switches off automatically
- ③ Ambient temperature
Non-Ex devices: min. (Compact) -36°C / -33°F, min. (Remote) -37°C / -34.6°F max. +80°C / +176°F
Devices with Hazardous Location approvals: see supplementary instructions
- ④ Process pressure
-1...40 barg / -14.5...580 psig



WARNING!

The process connection temperature range must agree with the temperature limits of the gasket material.

Permitted temperature ranges for gaskets

Gasket material	Permitted temperature ranges for gaskets			
	Standard version		High-Temperature version	
	[°C]	[°F]	[°C]	[°F]
FKM/FPM	-40...+150	-40...+302	-40...+300	-40...+572
Kalrez® 6375	-20...+150	-4...+302	-20...+300	-4...+572
EPDM	-50...+150	-58...+302	-50...+250	-58...+482

Compact version:

Ambient temperature / flange temperature, flange and threaded connection, in °C

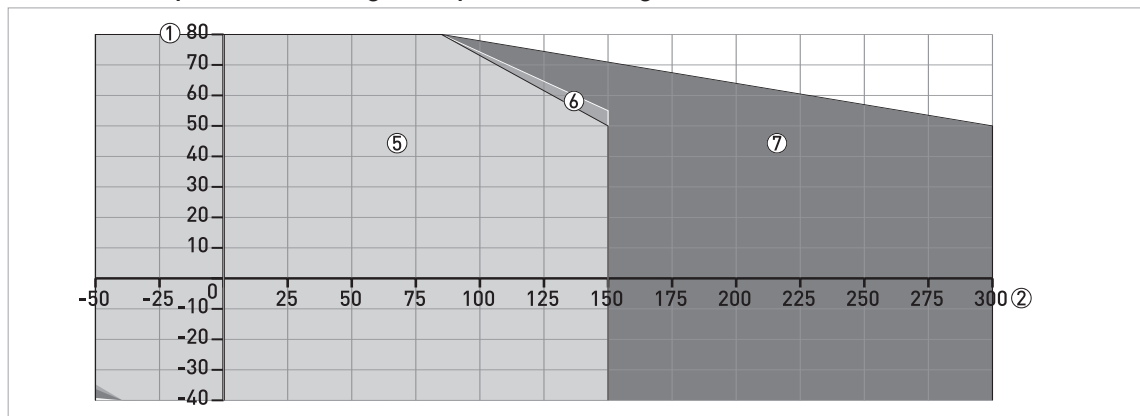

Figure 2-7: Compact version: Ambient temperature / flange temperature, flange and threaded connection, in °C

Ambient temperature / flange temperature, flange and threaded connection, in °F

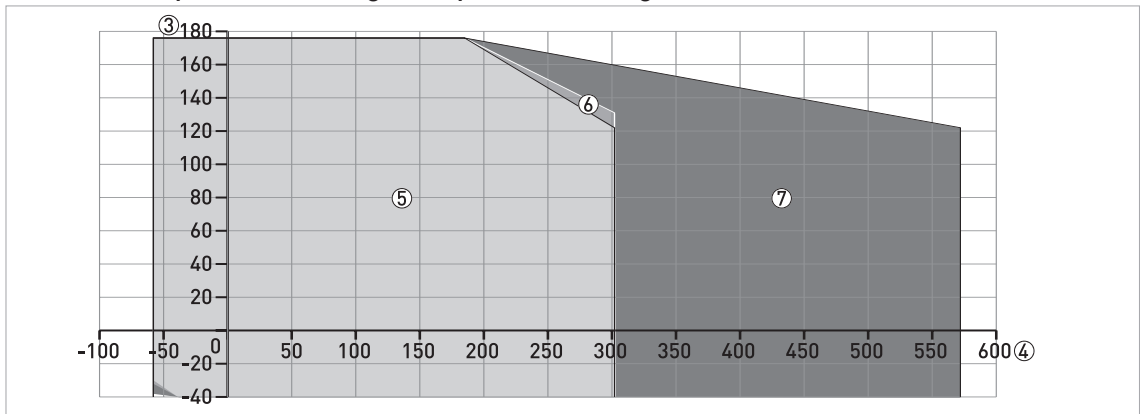

Figure 2-8: Compact version: Ambient temperature / flange temperature, flange and threaded connection, in °F

- ① Maximum ambient temperature, °C
- ② Maximum flange temperature, °C
- ③ Maximum ambient temperature, °F
- ④ Maximum flange temperature, °F
- ⑤ All probes
- ⑥ All versions of the 2 mm / 0.08" single cable probe
- ⑦ High-Temperature (HT) version of the Ø2 mm / 0.08" single cable probe

**INFORMATION!**

When the process temperature is $-50^{\circ}\text{C} / -58^{\circ}\text{F}$ and the device has a EPDM gasket, there is a de-rating for the ambient temperature:

Compact version

$T_a = -36^{\circ}\text{C} / -32.8^{\circ}\text{F}$ for the $\text{Ø}2 \text{ mm} / 0.08''$ single cable probe

$T_a = -39^{\circ}\text{C} / -38.2^{\circ}\text{F}$ for the high-temperature (HT) version of the $\text{Ø}2 \text{ mm} / 0.08''$ single cable probe

$T_a = -37^{\circ}\text{C} / -34.6^{\circ}\text{F}$ for all other probes

Hygienic applications only: When the process temperature is $-45^{\circ}\text{C} / -49^{\circ}\text{F}$ and the device has an EPDM gasket, there is a de-rating for the ambient temperature. $T_a = -39^{\circ}\text{C} / -38.2^{\circ}\text{F}$

Remote version (probe housing):

Ambient temperature / flange temperature, flange and threaded connection, in °C

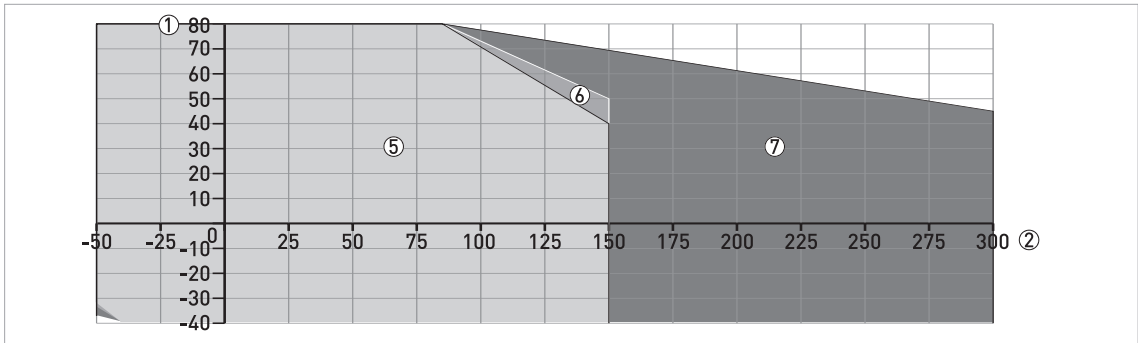

Figure 2-9: Remote version (probe housing): Ambient temperature / flange temperature, flange and threaded connection, in °C

Ambient temperature / flange temperature, flange and threaded connection, in °F

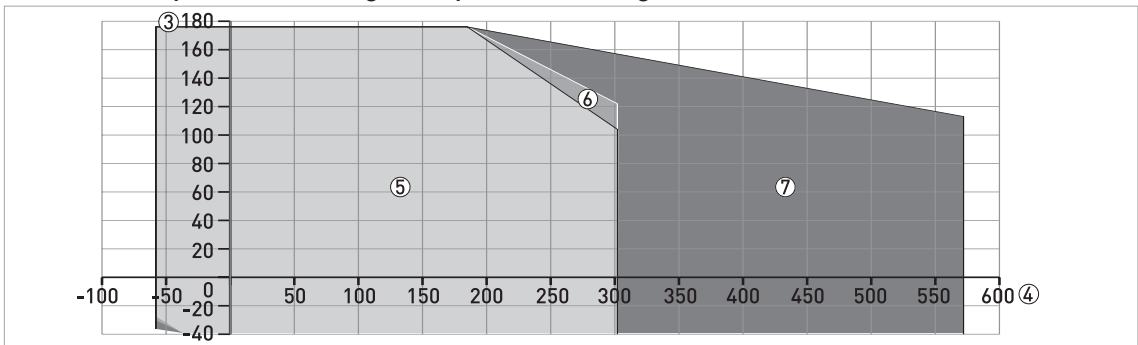

Figure 2-10: Remote version (probe housing): Ambient temperature / flange temperature, flange and threaded connection, in °F

- ① Maximum ambient temperature, °C
- ② Maximum flange temperature, °C
- ③ Maximum ambient temperature, °F
- ④ Maximum flange temperature, °F
- ⑤ All probes
- ⑥ All versions of the 2 mm / 0.08" single cable probe
- ⑦ High-Temperature (HT) version of the Ø2 mm / 0.08" single cable probe



INFORMATION!

When the process temperature is -50°C / -58°F and the device has a EPDM gasket, there is a de-rating for the ambient temperature:

Remote version (probe housing)

$T_a = -35^\circ\text{C} / -31^\circ\text{F}$ for the Ø2 mm / 0.08" single cable probe

$T_a = -39^\circ\text{C} / -38.2^\circ\text{F}$ for the high-temperature (HT) version of the Ø2 mm / 0.08" single cable probe

$T_a = -36^\circ\text{C} / -32.8^\circ\text{F}$ for all other probes

Hygienic applications only: When the process temperature is -45°C / -49°F and the device has an EPDM gasket, there is a de-rating for the ambient temperature. $T_a = -39^\circ\text{C} / -38.2^\circ\text{F}$

2.7.2 General information for nozzles



CAUTION!

Follow these recommendations to make sure that the device measures correctly. They have an effect on the performance of the device.



CAUTION!

Do not put the process connection near to the product inlet. If the product that enters the tank touches the probe, the device will measure incorrectly.

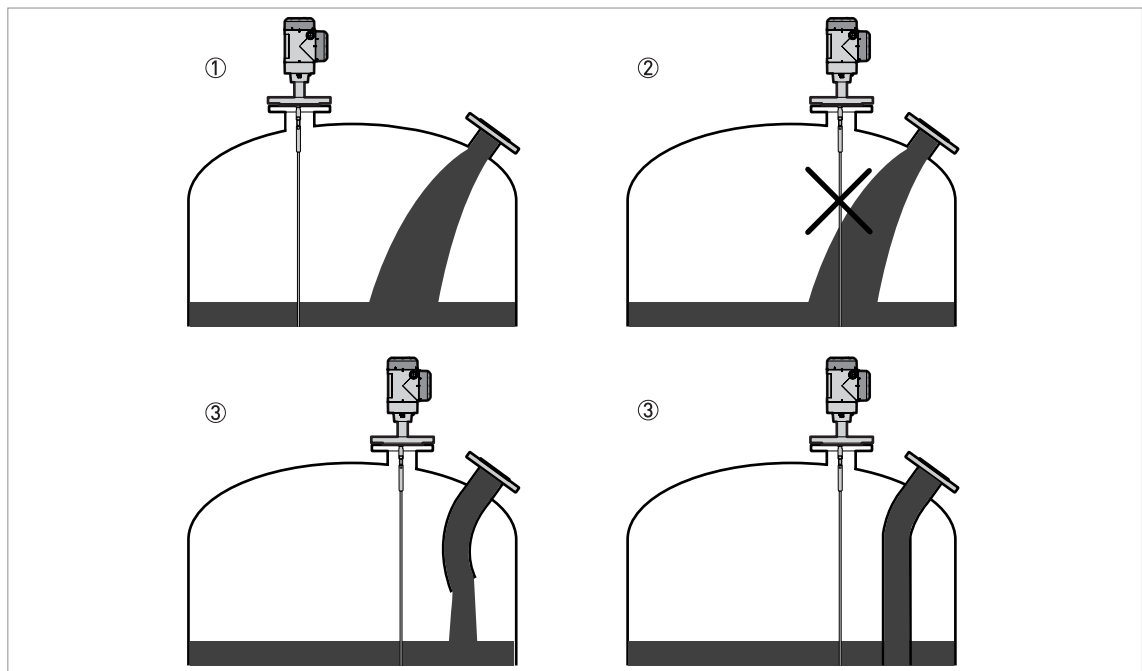

Figure 2-11: Do not put the device near to a product inlet

- ① The device is in the correct position.
- ② The device is too near to the product inlet.
- ③ If it is not possible to put the device in the recommended position, install a deflector pipe.

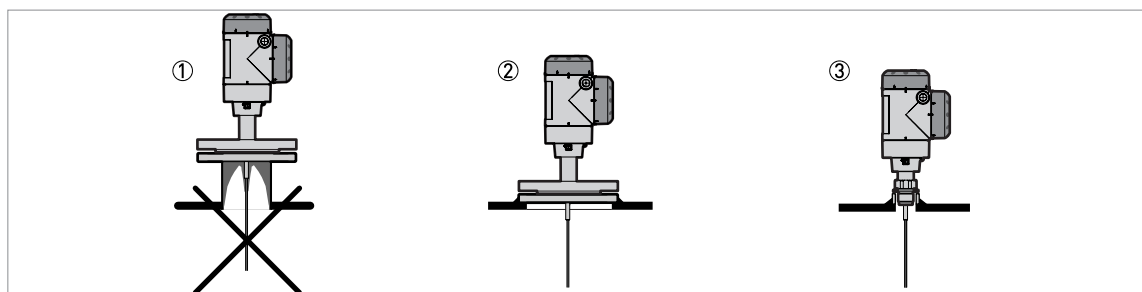

Figure 2-12: How to prevent build-up of product around the process connection

- ① If product particles are likely to collect in holes, a nozzle is not recommended.
- ② Attach the flange directly to the tank.
- ③ Use a threaded connection to attach the device directly to the tank.

For single cable and single rod probes:

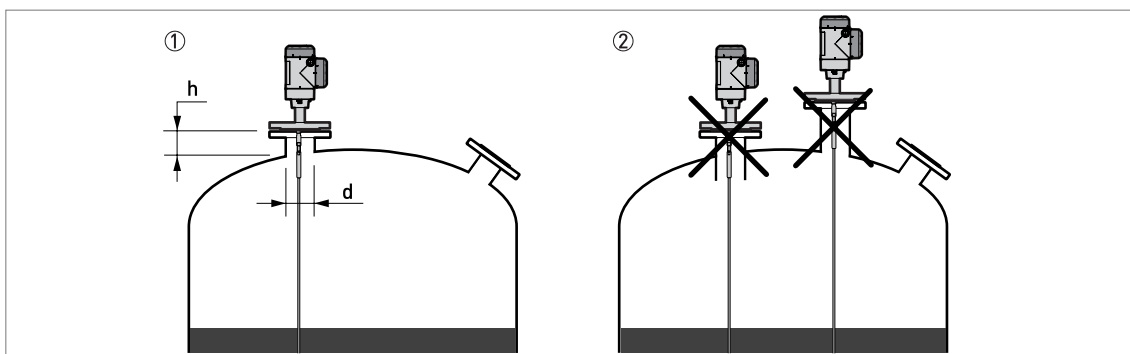

Figure 2-13: Recommended nozzle dimensions for single rod and single cable probes

- ① Recommended conditions: $h \leq d$, where h is the height of the tank nozzle and d is the diameter of the tank nozzle.
- ② The end of the nozzle must not have an extension into the tank. Do not install the device on a high nozzle.



CAUTION!

If the device is installed on a high nozzle, make sure that the probe does not touch the side of the nozzle (attach the probe end etc.).



Figure 2-14: Sockets for threaded process connections

- ① Recommended installation
- ② The end of the socket must not have an extension into the tank

For double cable and double rod probes:

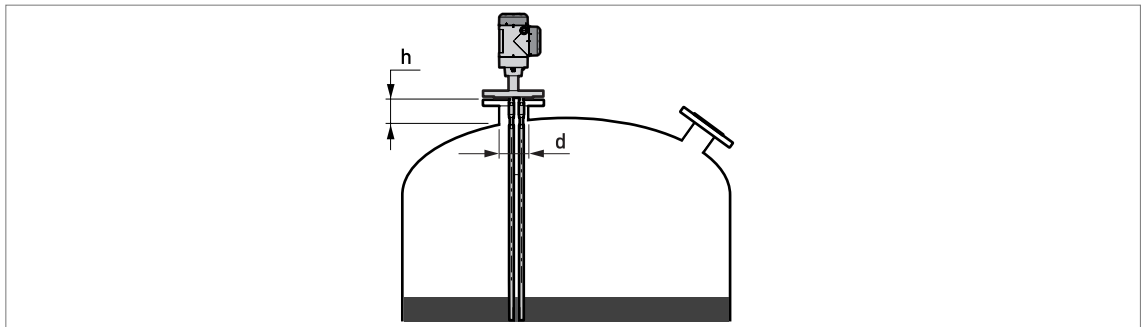

Figure 2-15: Recommended nozzle dimensions for double rod and double cable probes
 $d \geq 50 \text{ mm} / 2''$, where d is the diameter of the tank nozzle

For coaxial probes:

If your device has a coaxial probe, you can ignore these installation recommendations.



CAUTION!

Install coaxial probes in clean liquids that are not too viscous.

2.7.3 Installation requirements for concrete roofs

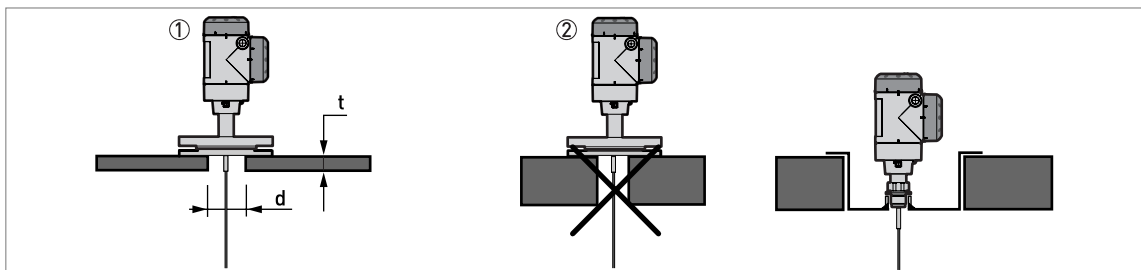

Figure 2-16: Installation on a concrete roof

- ① The diameter, d , of the hole must be greater than the thickness, t , of the concrete.
- ② If the thickness, t , of the concrete is greater than the diameter, d , of the hole, install the device in a recess.

2.8 Installation recommendations for liquids

2.8.1 General requirements

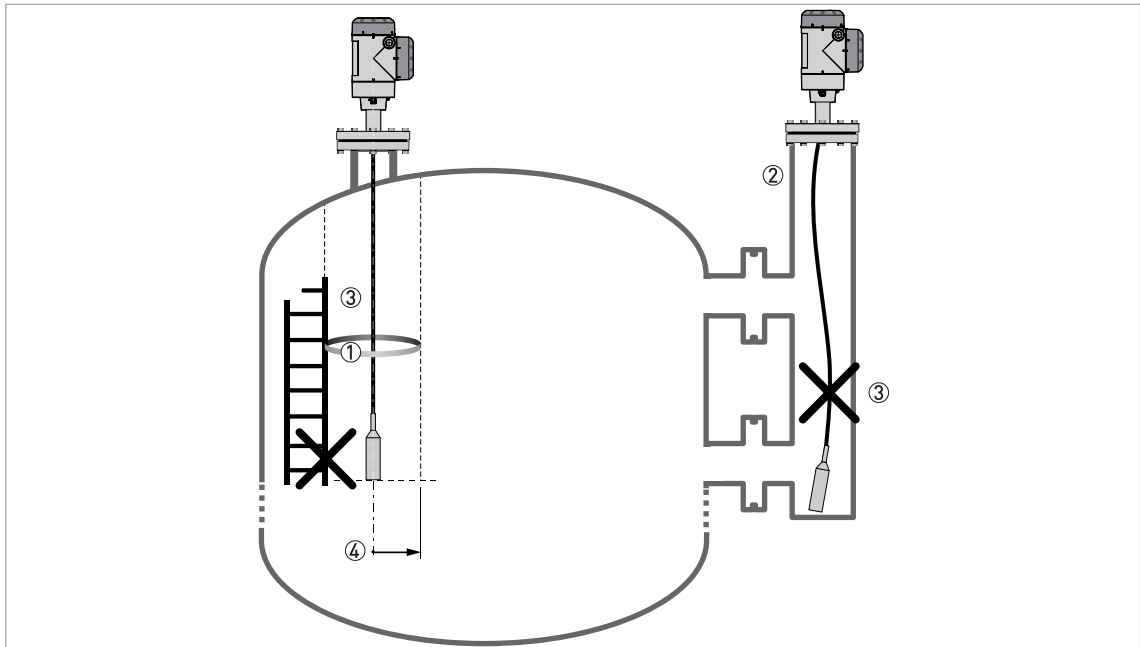

Figure 2-17: Installation recommendations for liquids

- ① The electromagnetic (EM) field generated by the device. It has a radius of R_{min} . Make sure that the EM field is clear of objects and product flow. Refer to the table that follows.
- ② If there are too many objects in the tank, install a bypass chamber or stilling well.
- ③ Keep the probe straight. If the probe is too long, shorten the probe length. Make sure that the device is configured with the new probe length. For more data on the procedure, refer to the handbook.
- ④ Empty space. Refer to the table that follows.

Clearance between the probe and other objects in the tank

Probe type	Empty space (radius, R_{min}), around the probe	
	[mm]	[inches]
Coaxial	0	0
Double rod / cable	100	4
Single rod / cable	300	12

2.8.2 Installation in standpipes (stilling wells and bypass chambers)

Use a standpipe if:

- The liquid is very turbulent or agitated.
- There are too many other objects in the tank.
- The device is measuring a liquid in a tank with a floating roof.

For more data, refer to the Handbook.

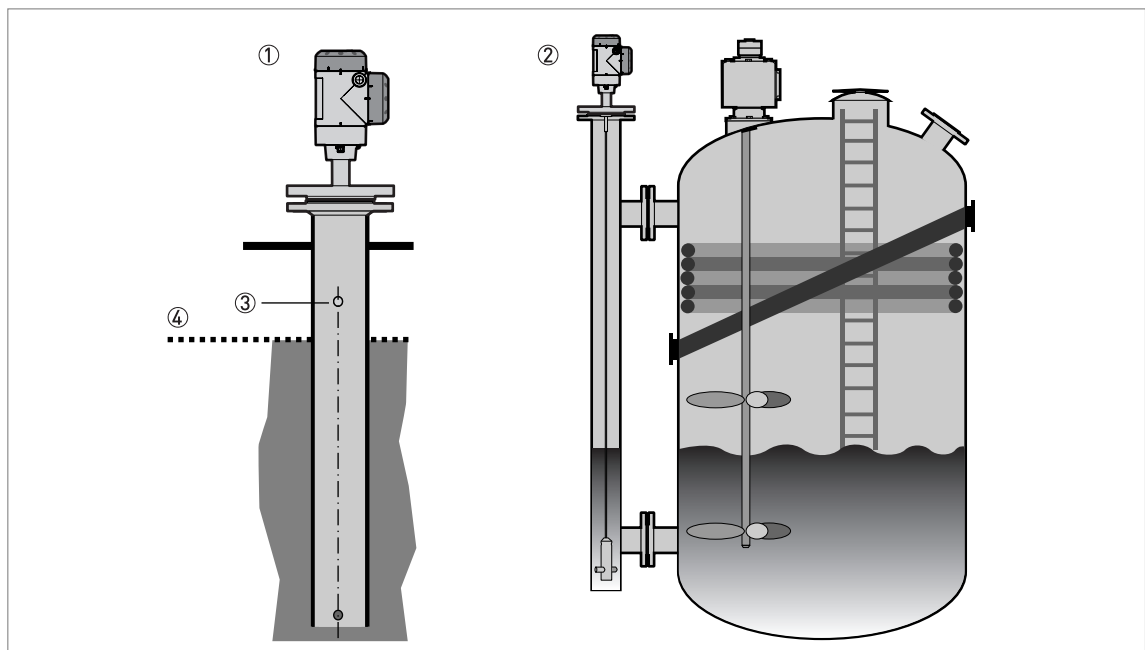

Figure 2-18: Installation recommendations for standpipes (stilling wells and bypass chambers)

- ① Stilling well
- ② Bypass chamber
- ③ Vent
- ④ Level of the liquid



INFORMATION!

Stilling wells are not necessary for devices with coaxial probes. But if there is a sudden change in diameter in the stilling well, we recommend that you install a device with a coaxial probe.

2.9 Installation recommendations for solids

2.9.1 Nozzles on conical silos

We recommend that you prepare the installation when the silo is empty.



DANGER!

Risk of electrostatic discharge (ESD): The device is resistant to electrostatic discharges of up to 30 kV, but it is the responsibility of the fitter and the user to prevent ESD.



CAUTION!

Install the device at the correct location to measure level correctly and prevent too much bending and traction. If necessary, attach the probe to the bottom of the tank.

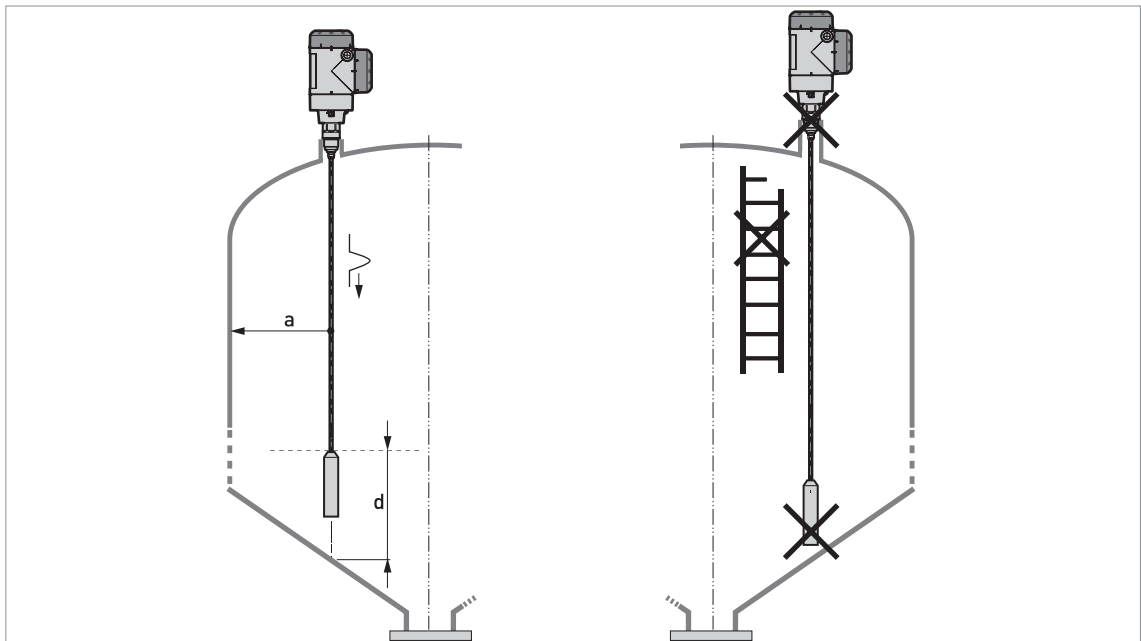

Figure 2-19: Installation recommendations for solids

$a \geq 300 \text{ mm} / 12''$

$d \geq 300 \text{ mm} / 12''$

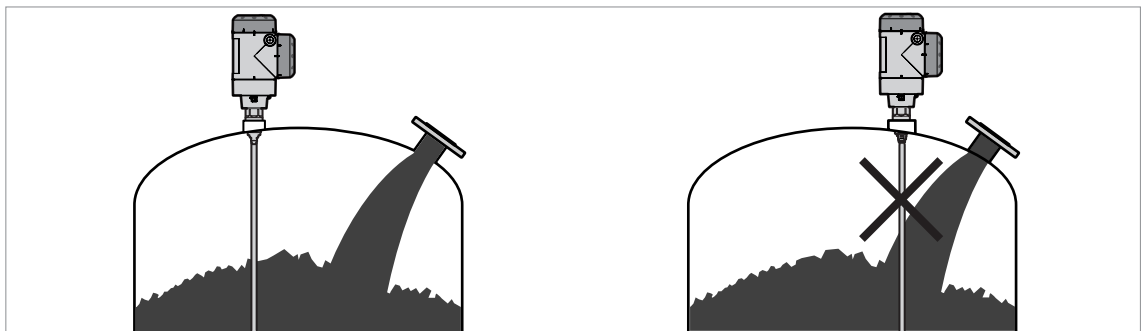

Figure 2-20: Do not install the probe near to a product inlet

2.9.2 Traction loads on the probe

Traction load depends on:

- The height and shape of the tank.
- The particle size and density.
- The rate at which the tank is emptied.



CAUTION!

Risk of damage to the cable probe. High loads can break the cable.

If the load on the Ø8 mm / 0.32" single cable probe is more than 3500 kg / 7700 lb, contact your supplier. If the load on the Ø4 mm / 0.16" single cable probe is more than 875 kg / 1930 lb, contact your supplier.



CAUTION!

Make sure that the tank roof is resistant to deformation at high loads.

Estimated traction load on the probe in kg

Material	Probe length, 10 m	Probe length, 20 m	Probe length, 30 m
	[kg]		
Cement	1000	2000	3000
Fly ash	500	1000	1500
Wheat	300	500	1200

Estimated traction load on the probe in lb

Material	Probe length, 33 ft	Probe length, 65 ft	Probe length, 98 ft
	[lb]		
Cement	2200	4410	6520
Fly ash	1100	2200	3300
Wheat	660	1100	2650

2.10 How to install the device on the tank

2.10.1 How to assemble the single rod probe (single-piece probe)

**INFORMATION!**

This procedure is for devices with single rod probes that are not segmented (single-piece probes).

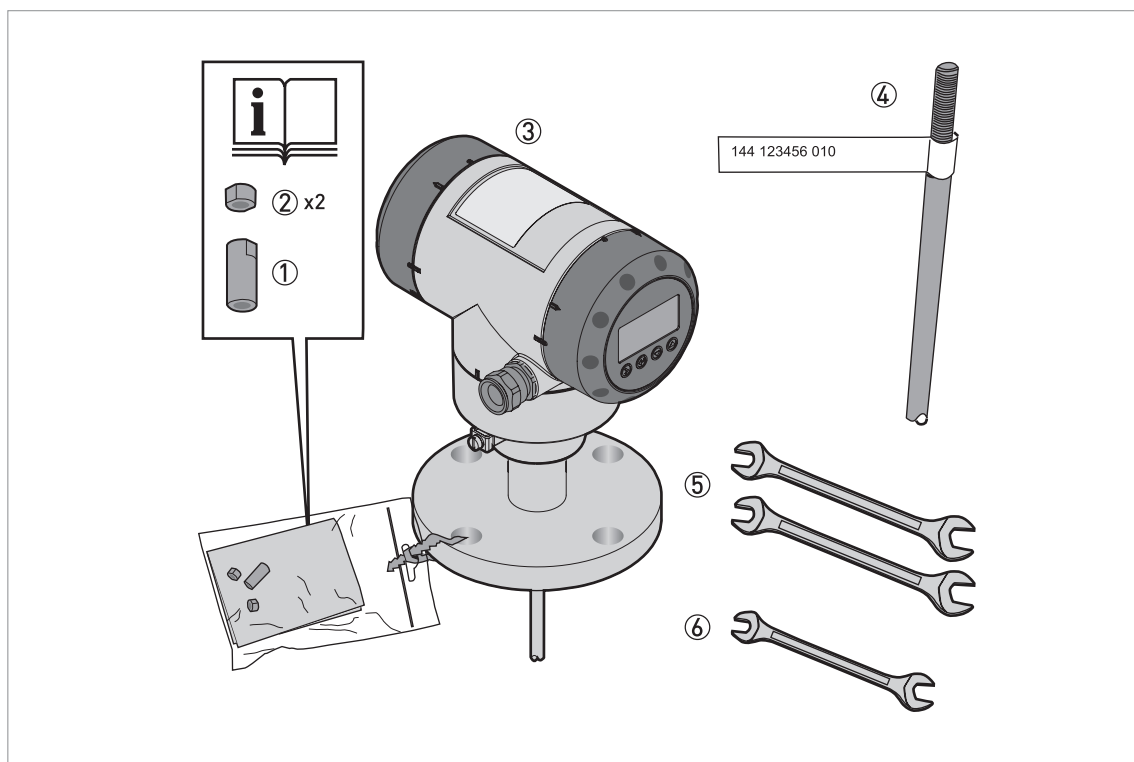

Figure 2-21: Equipment needed to assemble the device

- ① Union nut
- ② 2 locking nuts
- ③ Housing assembly
- ④ Single rod probe
- ⑤ Tools: two 8 mm open-ended wrenches (not supplied)
- ⑥ Tools: one 7 mm open-ended wrench (not supplied)

Part 1: Check the order number on each component

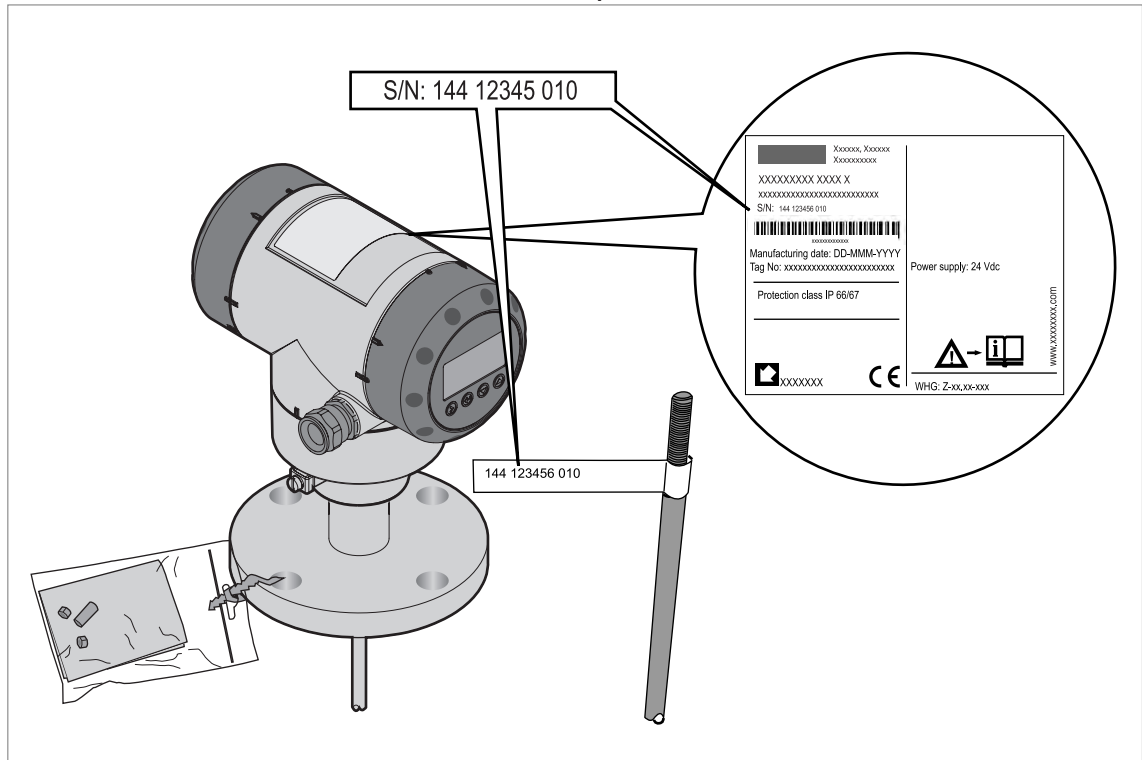

Figure 2-22: Part 1: Check the order number on each component



- Make sure that the housing and the single rod have the same ID numbers.
- Remove the sticker from the probe.

Part2: How to attach the locking nut and union nut

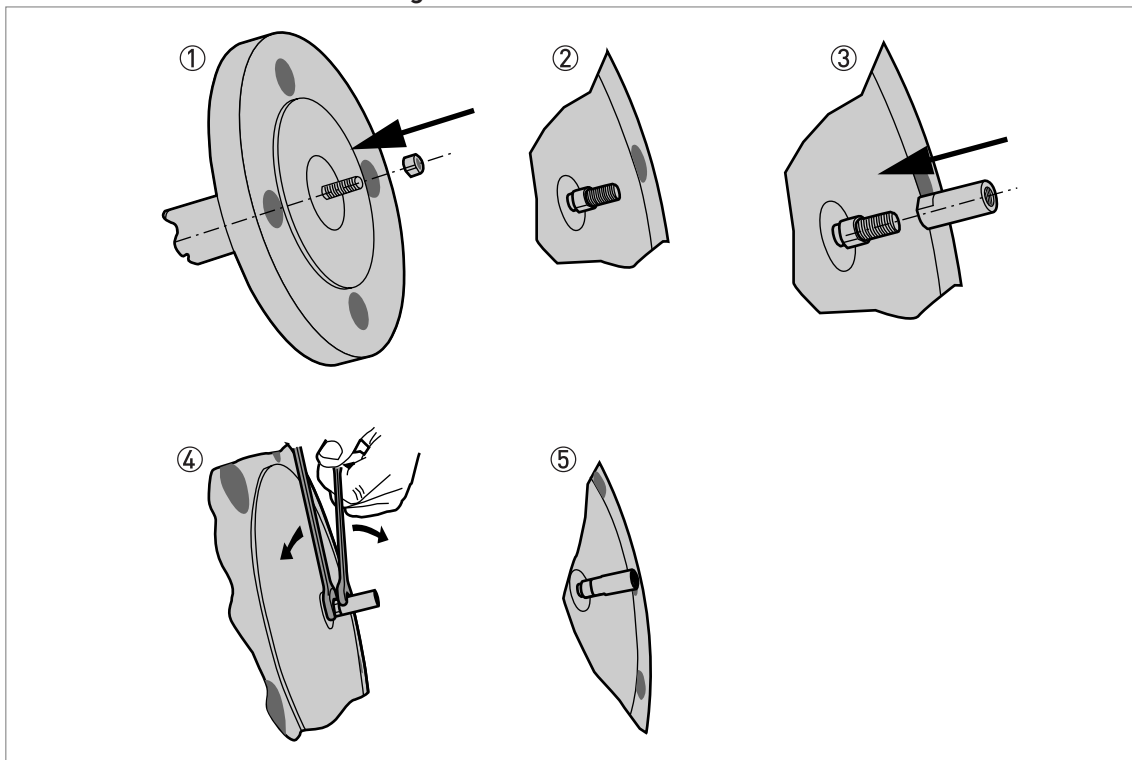

Figure 2-23: Part2: How to attach the locking nut and union nut



- ① Attach a locking nut to the housing assembly.
- ② Make sure that the nut is fully engaged on the thread.
- ③ Attach the union nut to the housing assembly.
- ④ Tighten these nuts with the two 8 mm open-ended wrenches.
- ⑤ Continue the assembly procedure on the page that follows.

Part 3: How to attach the locking nut and union nut

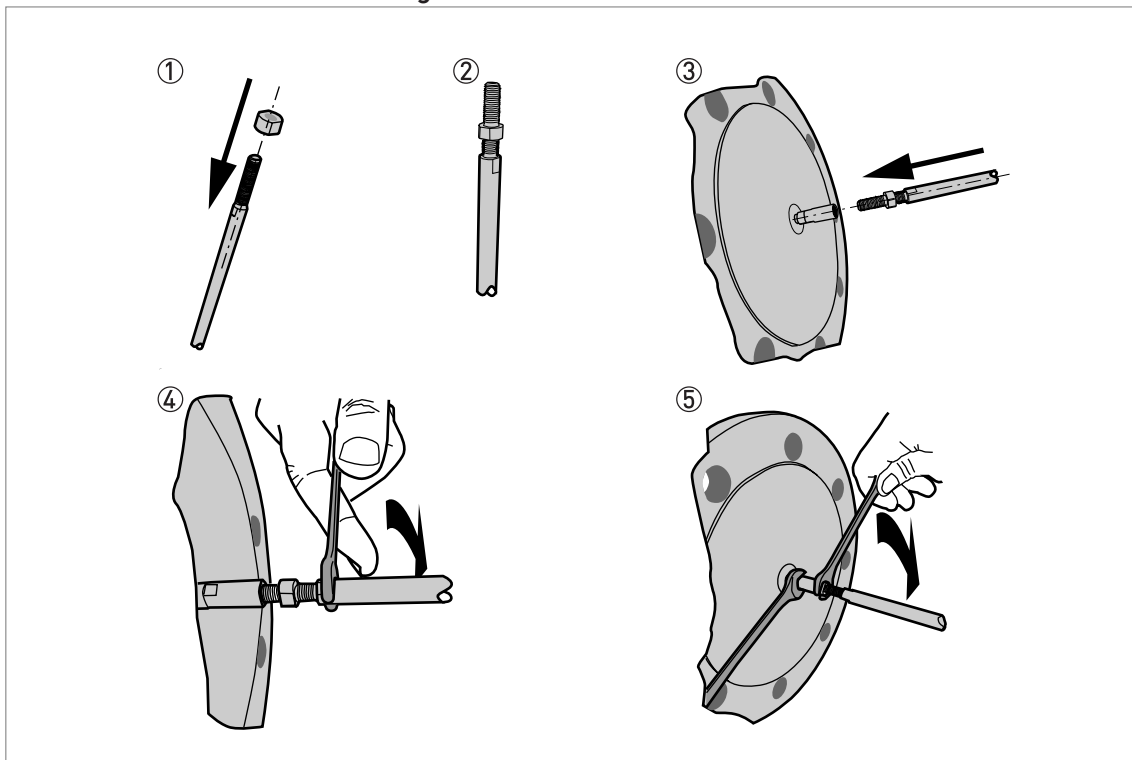

Figure 2-24: Part 3: How to attach the locking nut and union nut

**CAUTION!**

Support the probe.



- ① Attach a locking nut to the single rod.
- ② Make sure that the locking nut is engaged $\frac{3}{4}$ along the length of the thread.
- ③ Attach the single rod to the union nut. Make sure the probe touches the housing assembly.
- ④ Tighten the single probe with a 7 mm open-ended wrench.
- ⑤ Tighten the locking nut against the union nut with two 8 mm open-ended wrenches.

2.10.2 How to assemble the single rod probe (segmented probe)

**INFORMATION!**

This procedure is for devices with single rod probes that are segmented.

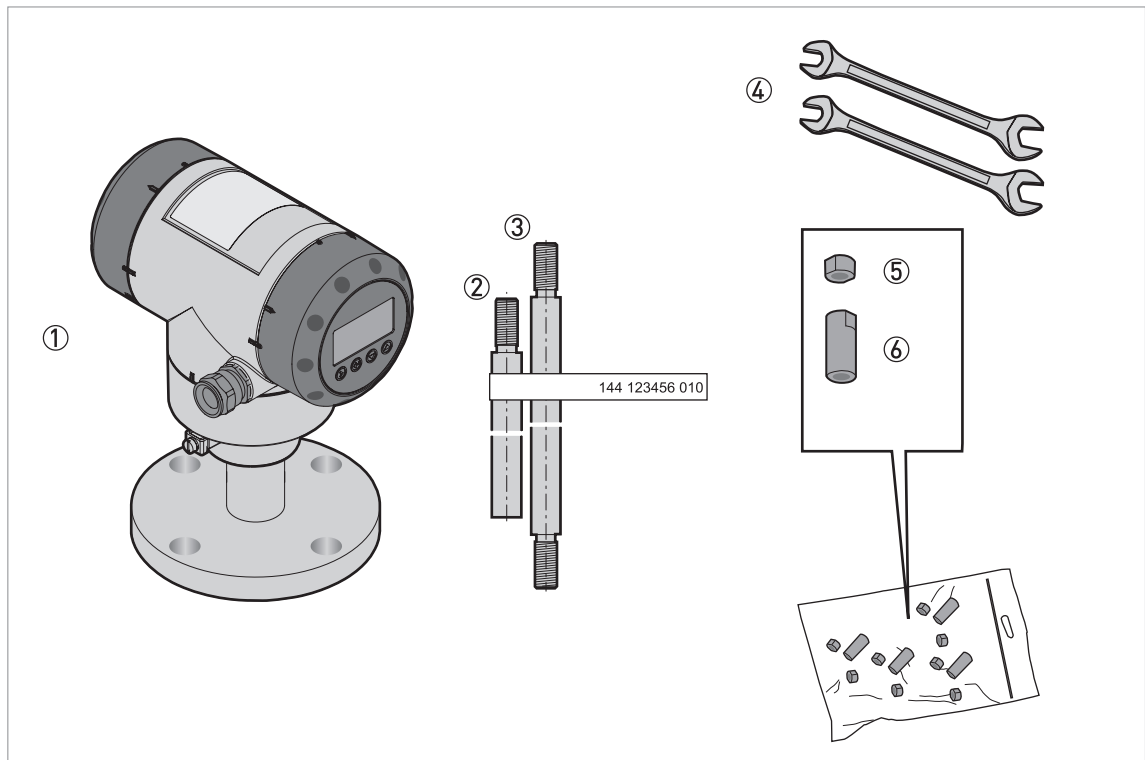

Figure 2-25: Equipment needed to assemble the single rod probe (segmented)

- ① Converter and process connection
- ② Bottom (quantity: 1) segment of the rod probe
- ③ Top and middle (if more than one) segments of the rod probe
- ④ Tools: two 8 mm open-end wrenches (not supplied)
- ⑤ Lock nuts (2 lock nuts per segment)
- ⑥ Union nut (1 union nut per segment)

**CAUTION!**

Make sure that the housing and the single rod have the same ID numbers.

Part 1: How to assemble the segmented single rod probe

Figure 2-26: Part 1: How to assemble the segmented single rod probe

**CAUTION!**

Make sure that the nuts are tight and the rod probe cannot loosen.

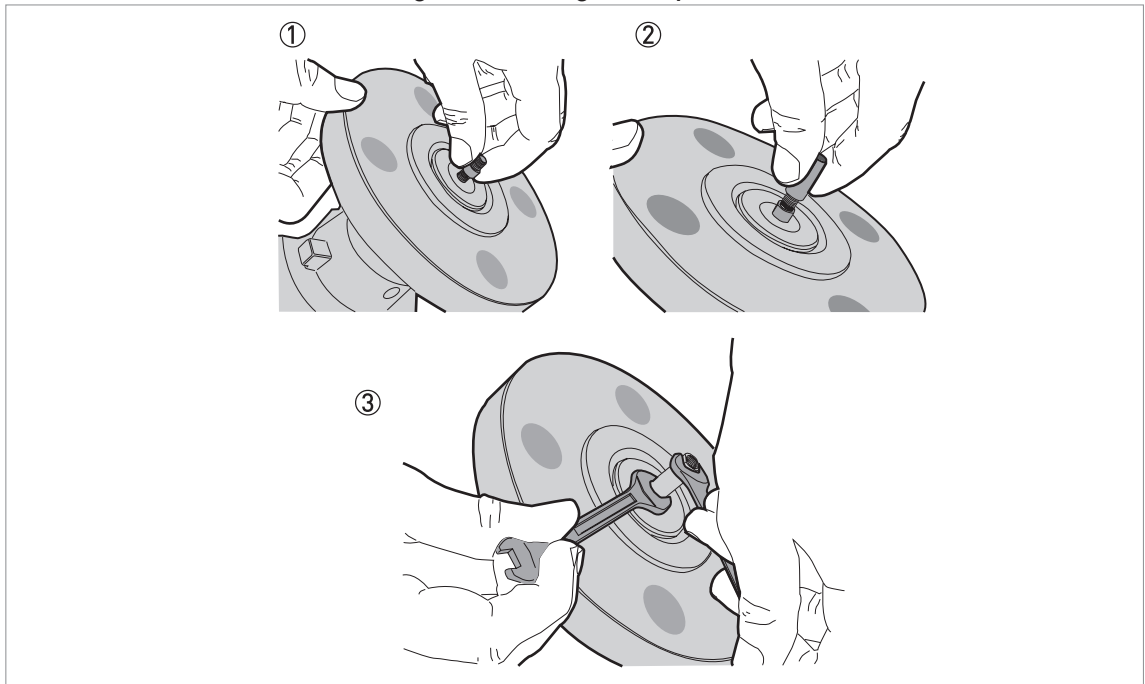

- ① Attach a lock nut to the threaded rod below the process connection. Turn the nut until it is $\frac{3}{4}$ along the length of the rod.
- ② Attach a union nut to the threaded rod below the process connection.
- ③ Use two 8 mm open-end wrenches to tighten the union nut against the lock nut.

Part 2: How to assemble the segmented single rod probe

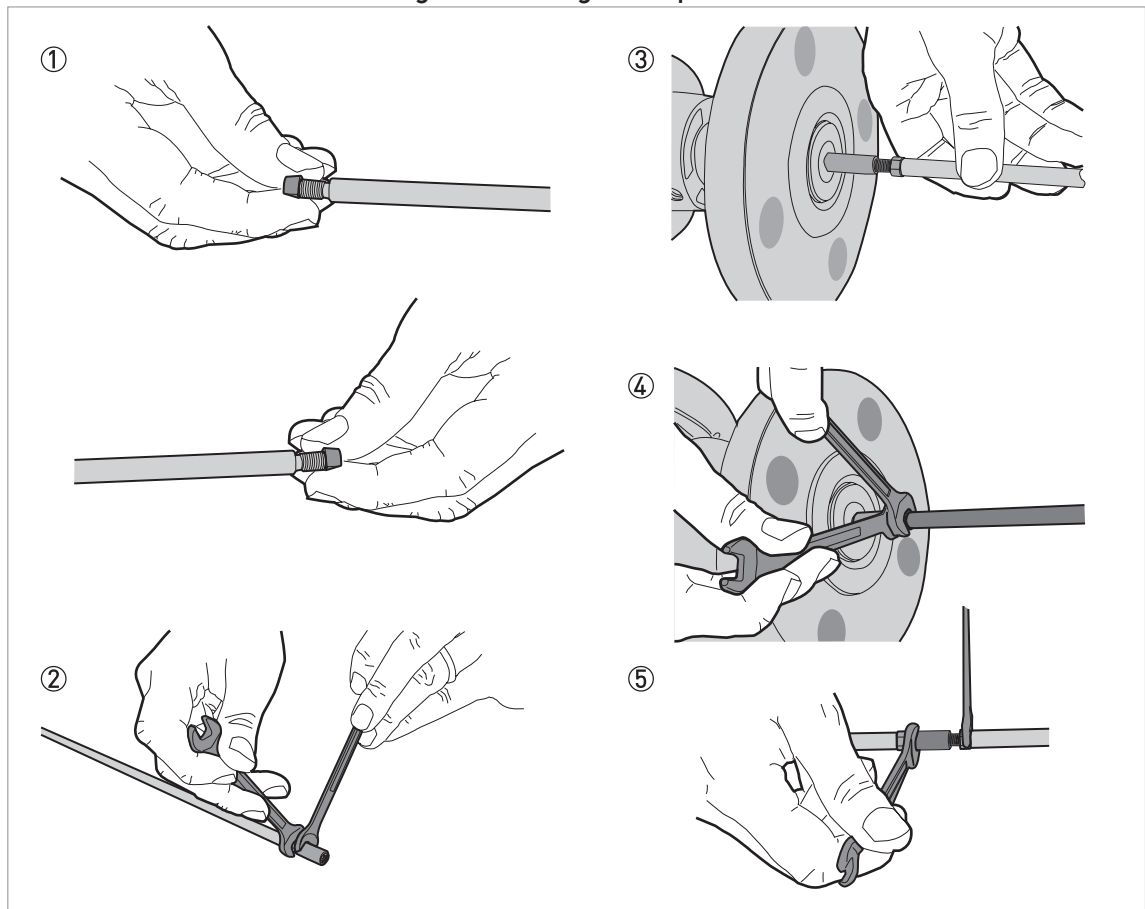

Figure 2-27: Part 2: How to assemble the segmented single rod probe

**WARNING!**

Put a support below the probe to prevent deformation.

**CAUTION!**

Make sure that the nuts are tight and the rod probe cannot loosen.



- ① Attach a lock nut to each end of the rod probe segments.
- ② Attach a union nut to the bottom end of each rod probe segment, but not to the bottom segment. Use two 8 mm open-end wrenches to tighten the union nut against the lock nut.
- ③ Attach the top segment of the rod probe to the union nut below the process connection. Use two 8 mm open-end wrenches to tighten the union nut against the lock nut on the rod probe.
- ④ Attach the middle segment of the rod probe to the union nut on the top segment (if there are middle segments). Use two 8 mm open-end wrenches to tighten the union nut against the lock nut. Repeat this step for the other segments.
- ⑤ Attach the bottom segment of the rod probe to the union nut on the top segment. Use two 8 mm open-end wrenches to tighten the union nut against the lock nut.

2.10.3 How to assemble the segmented coaxial probe

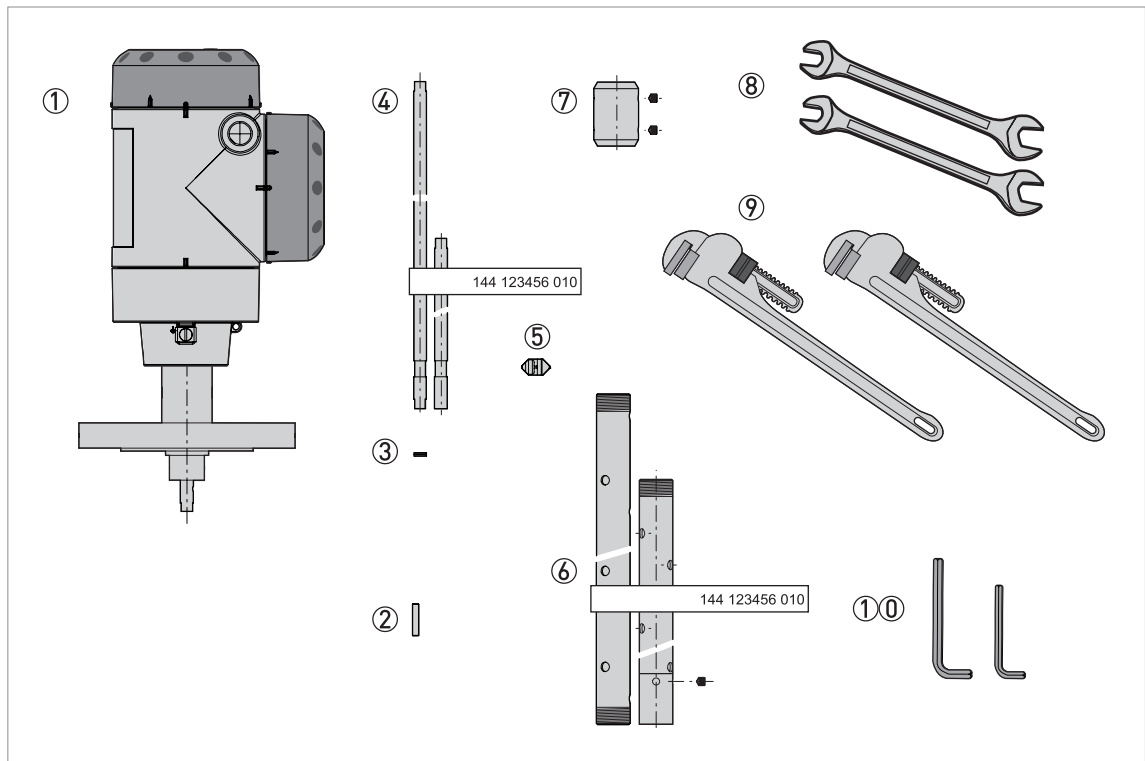

Figure 2-28: Equipment needed to assemble the coaxial probe

- ① Converter and process connection
- ② HC M4x20 screws (1 screw per probe segment)
- ③ Lock washers (1 pair of washers per probe segment)
- ④ Top (quantity: 1), middle (quantity: 1 or more) and bottom (quantity: 1 – with 1 socket set screw M5x5) segments of the signal rod
- ⑤ PTFE spacer (1 spacer per probe segment)
- ⑥ Middle (quantity: 1 or more) and bottom (quantity: 1) segments of the coaxial tube
- ⑦ Union nut with 2 socket set screws M5x5 (1 union nut per segment of the coaxial tube)
- ⑧ Tools: two 7 mm open-end wrenches (not supplied)
- ⑨ Tools: two pipe (Stillson) wrenches (not supplied)
- ⑩ Tools: one 2.5 mm Allen wrench and one 2 mm Allen wrench (not supplied)



CAUTION!

Make sure that the housing and the single rod have the same ID numbers.

Part 1: How to assemble the segmented coaxial probe

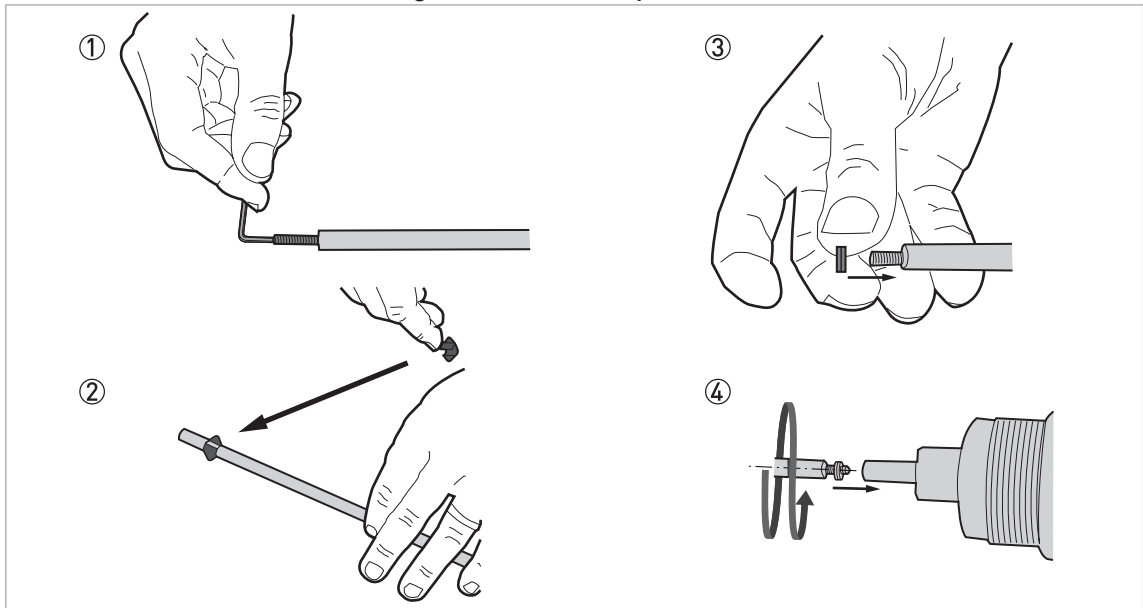

Figure 2-29: Part 1: How to assemble the segmented coaxial probe

**CAUTION!**

Do not attach the screw to the end of the rod segment that has a groove for the attachment of a PTFE spacer.



- ① Use a 2 mm Allen wrench to attach and tighten a HC M4×20 screw at the top of each rod segment (intermediary and end rod segments)
- ② Attach a PTFE spacer to the end of each rod segment that has a groove.
- ③ Attach a pair of lock washers at the top of each rod segment (intermediary and end rod segments)
- ④ Assemble one of the middle rod segments (with a pair of lock washers on the attached screw) and the signal rod below. Use two 7 mm open-ended wrenches to tighten the assembled parts to a torque of 2...3 Nm.

Part 2: How to assemble the segmented coaxial probe

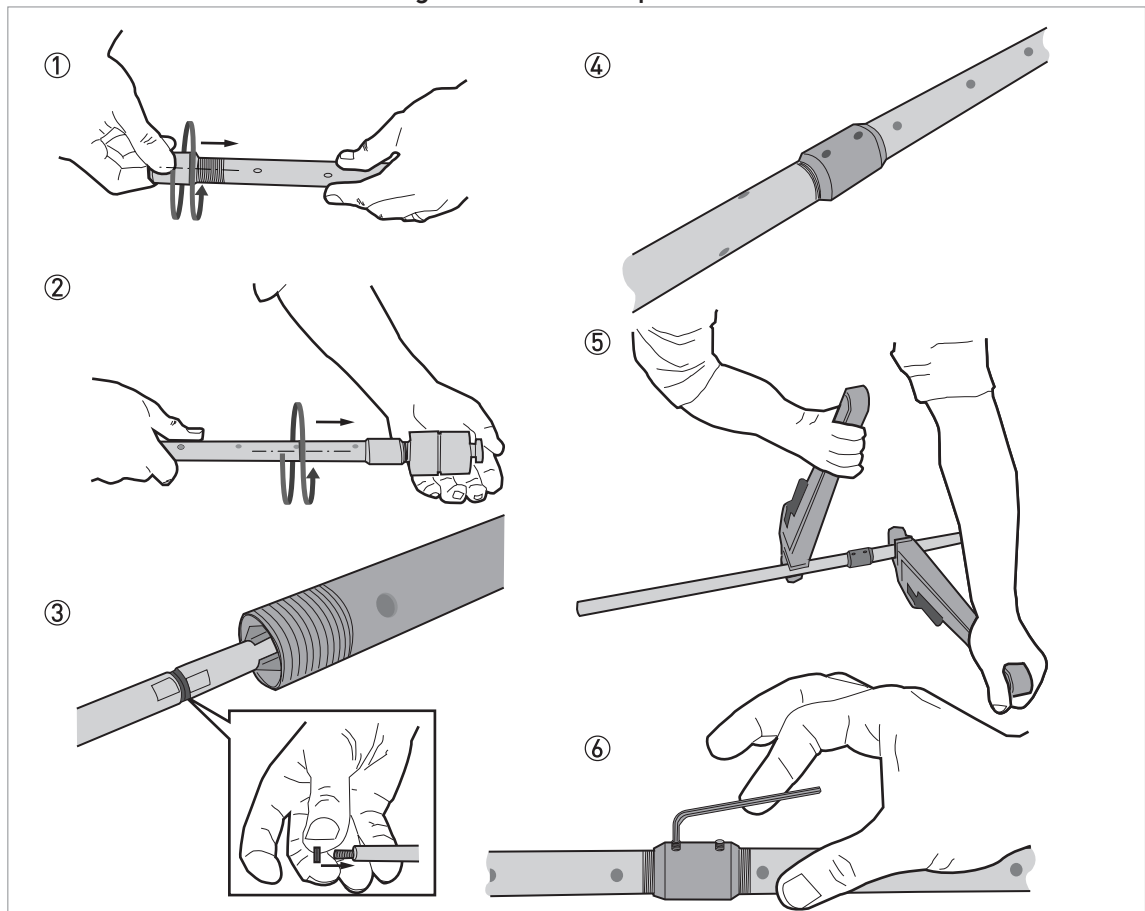

Figure 2-30: How to assemble the segmented coaxial probe: part 2

**WARNING!**

Be careful when you use the pipe wrenches. Make sure that the measuring tubes have no deformation.

**CAUTION!**

- Make sure that the screws are tight and the measuring tube cannot loosen.
- Make sure that the fitting for the lock screw is not aligned with a hole in the coaxial tube.



- ① Attach a union nut to each coaxial tube (middle and end tubes)
- ② Attach a middle tube segment to the coaxial probe stem. Do not use tools to tighten the assembled parts.
- ③ Assemble the next middle rod segment (with a pair of lock washers on the attached screw) and the top rod segment. Use two 7 mm open-ended wrenches to tighten the assembled parts to a torque of 2...3 Nm.
- ④ Assemble the next coaxial tube segment and the top coaxial tube segment. Do not use tools to tighten the assembled parts. Do steps (9) thru (10) again until the end rod segment and end coaxial tube are attached.
- ⑤ Use the 2 pipe wrenches to tighten the coaxial tubes in the lock nuts.
- ⑥ Use a 2.5 mm Allen wrench to attach and tighten the two HC M5x5 screws (lock screws) to the union nut.

Part 3: How to assemble the segmented coaxial probe

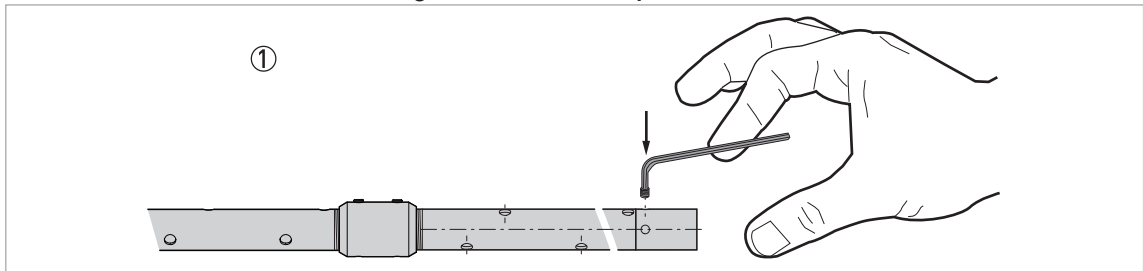

Figure 2-31: Part 3: How to assemble the segmented coaxial probe

**CAUTION!**

If the lock screw is not tight, the device will not measure correctly.



- ① Use a 2.5 mm Allen wrench to attach and tighten a HC M5x5 screw (lock screw) to the bottom segment of tube.

2.10.4 How to install a device with a flange connection

Equipment needed:

- Device
- Gasket (not supplied)
- Wrench (not supplied)

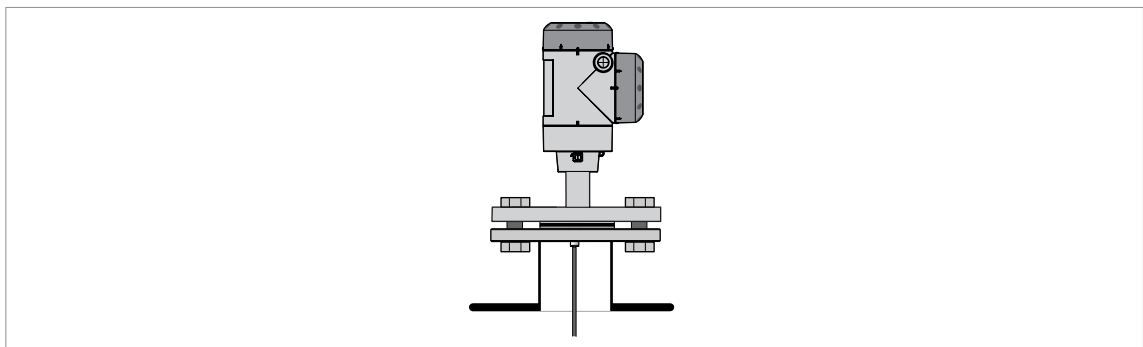

Figure 2-32: Flange connection



- Make sure that the flange on the nozzle is level.
- Make sure that you use the applicable gasket for the flange and the process.
- Align the gasket correctly on the flange facing of the nozzle.
- Lower the probe carefully into the tank.
- ➡ For more data on cable probes, refer to *How to install a cable probe in the tank* on page 34.
- Tighten the flange bolts.
- ➡ Refer to local rules and regulations for the correct torque to apply to the bolts.

2.10.5 How to install a device with a threaded connection

Equipment needed:

- Device
- Gasket (not supplied)
- 50 mm / 2" wrench (not supplied)

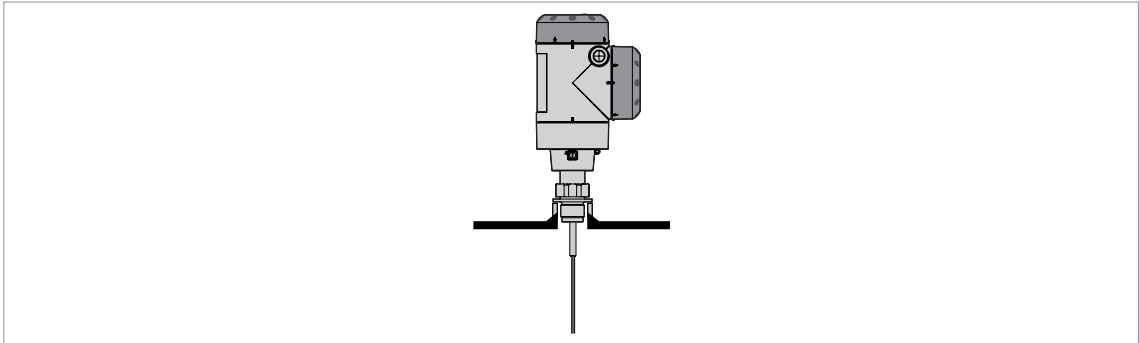

Figure 2-33: Threaded connection



- Make sure the tank connection is level.
- Make sure that you use the applicable gasket for the connection and the process.
- Align the gasket correctly.
- If the device is installed on a tank made of plastic or other non-conductive material, refer to *Recommendations for pits and tanks made of non-conductive materials* on page 36.
- Lower the probe carefully into the tank.
- ➡ For more data on cable probes, refer to *How to install a cable probe in the tank* on page 34.
- Use 50 mm / 2" wrench to attach the process connection to the tank.
- Tighten the nut.
- ➡ Refer to local rules and regulations for the correct torque to apply to the connection.



INFORMATION!

*If there is not sufficient clearance to install the device, remove the housing. Install the probe and then put the housing back on the process connection. For more data, refer to *How to turn or remove the signal converter* on page 35.*

2.10.6 How to install a device with a hygienic connection

**CAUTION!**

Make sure that you do not damage the polished parts.

**INFORMATION!**

To make the cleaning of the antenna easier, attach the device to a short socket.

Tri-Clamp®**Equipment needed:**

- Device with Tri-Clamp® adaptor
- Gasket (not supplied)
- Band clamp (not supplied)

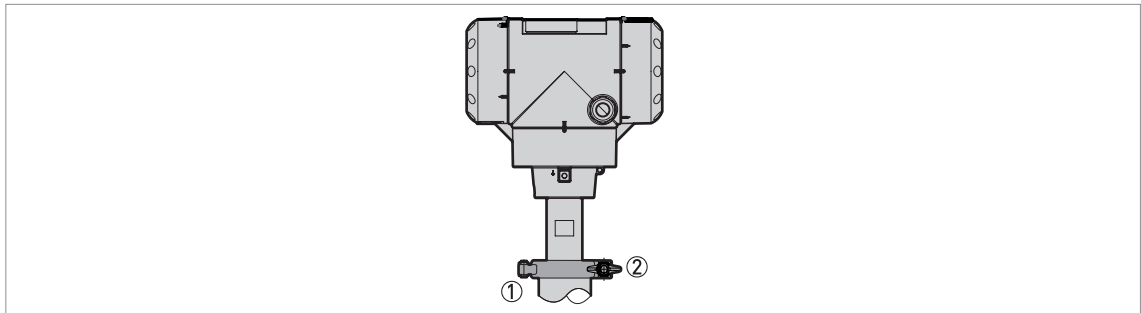

Figure 2-34: Tri-Clamp® connection

- ① Tank socket
- ② Clamp



- Make sure that the tank connection is level.
- Make sure that you use the applicable gasket for the connection dimensions and the process.
- Align the gasket correctly.
- Lower the device with the Tri-Clamp® adaptor carefully on the tank process connection.
- Attach the band clamp to the process connection.
- Tighten the band clamp.

DIN 11851

Equipment needed:

- Device with a DIN 11851 adaptor
- Gasket (not supplied)
- DIN 11851 nut

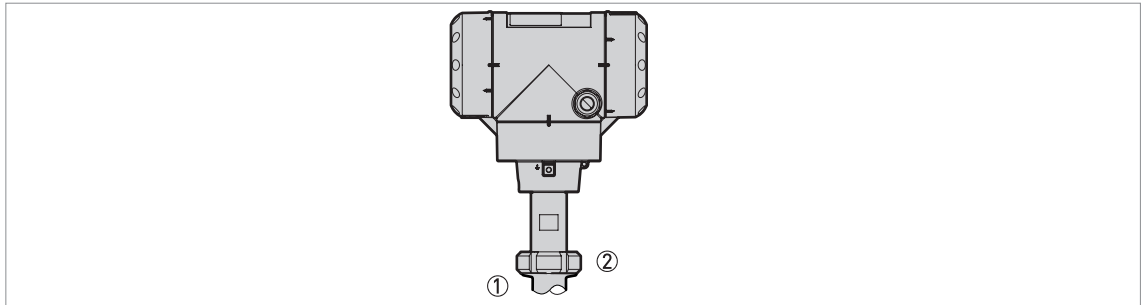

Figure 2-35: DIN 11851 connection

- ① Tank socket
- ② Union nut for DIN 11851 connection



- Make sure that the tank connection is level.
- Make sure that you use the applicable gasket for the connection dimensions and the process.
- Align the gasket correctly.
- Lower the device with a DIN 11851 adaptor carefully on the tank process connection.
- Turn the nut on the device process connection to attach the device to the tank.
- Tighten the connection.
- ➔ Refer to local rules and regulations for the correct torque to apply to the connection.

2.10.7 How to install a cable probe in the tank

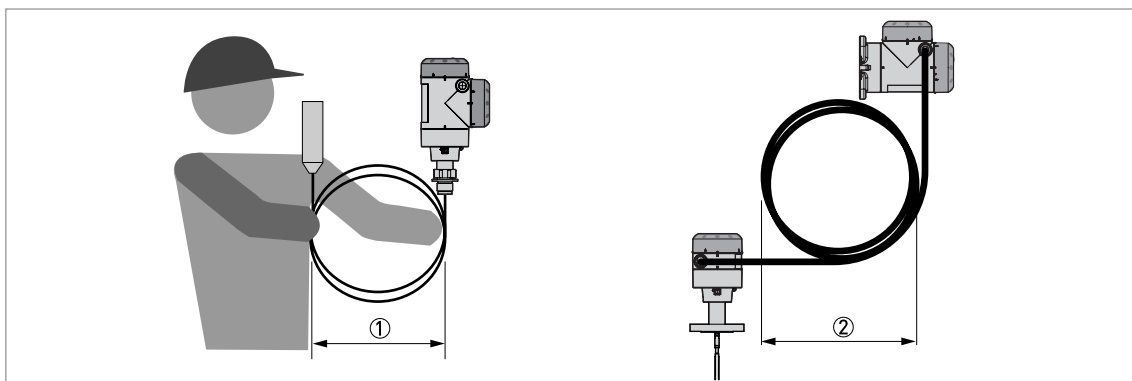

Figure 2-36: Wind cable probes and electrical cables carefully

- ① Do not wind cable probes less than 400 mm / 16" in diameter.
- ② Do not wind the flexible conduit less than 330 mm / 13" in diameter.

**WARNING!**

If you bend the probe too much, you will damage the device and it will not measure accurately.

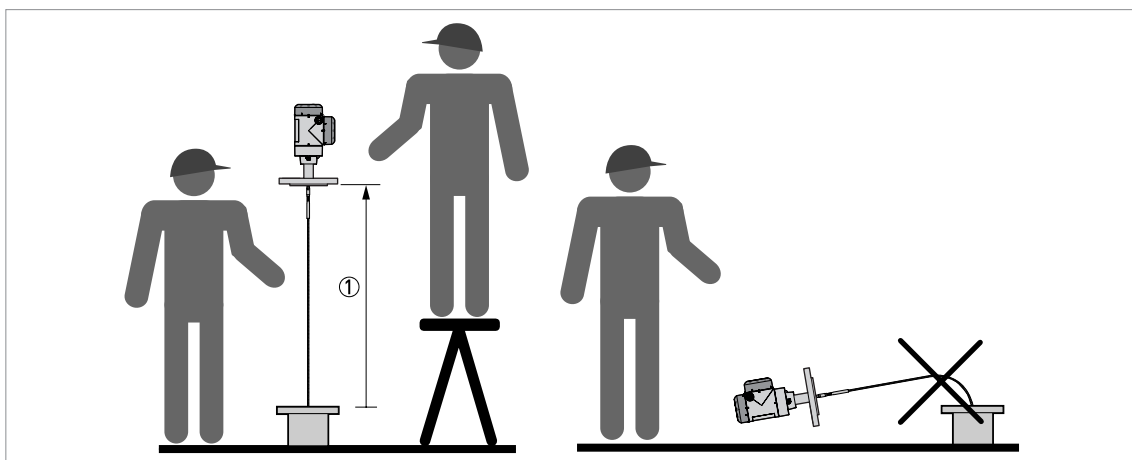

Figure 2-37: Installation of devices with cable probes

- ① >1 m / 3½ ft



- Use two persons to lift the housing and the probe above the process connection.
- Hold the device 1 m / 3½ ft above the tank.
- Unwind the probe carefully into the tank.

2.10.8 How to turn or remove the signal converter

The converter turns 360°. The converter can be removed from the process connection assembly under process conditions.

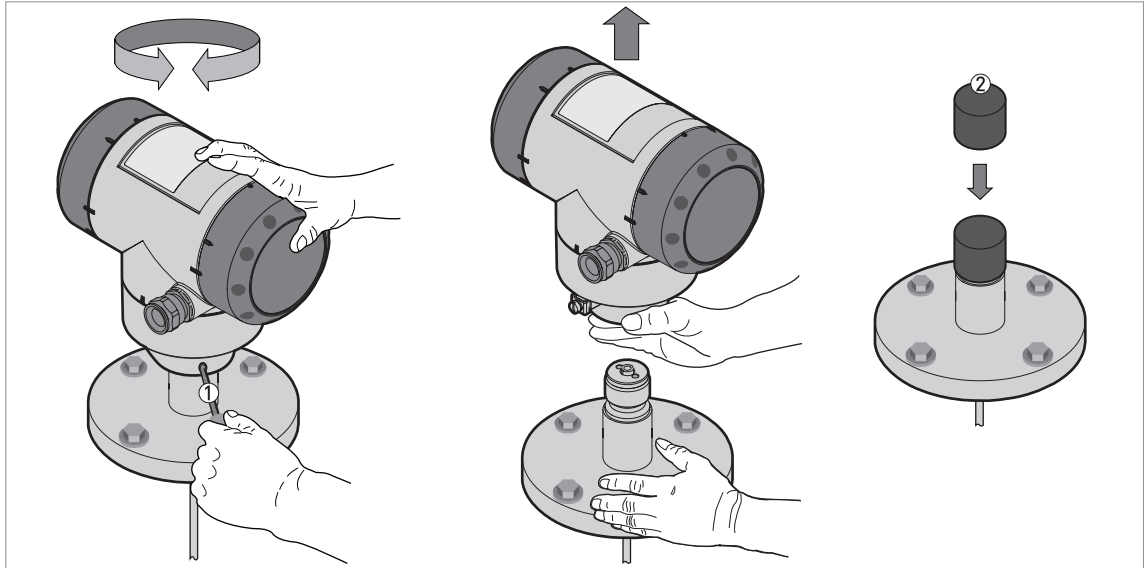

Figure 2-38: How to turn or remove the signal converter

- ① Tool: 5 mm Allen wrench (not supplied) for the lock screw on the signal converter
- ② Cover for the coaxial hole on top of the process connection assembly (not supplied)



CAUTION!

If you remove the housing, put a cover on the coaxial hole on top of the process connection assembly.

When the housing is attached to the process connection assembly, tighten the lock screw with the 5 mm Allen wrench ①.

2.10.9 Recommendations for pits and tanks made of non-conductive materials



If you have a device with a single rod or a single cable probe and a thread connection, obey these instructions:

- Put a metal sheet between the device and the process connection.
- ➡ It must have a diameter greater than 200 mm / 8".
- Make sure that the metal sheet is in contact with the thread stop on the device.

We recommend that you use $DN \geq 200$ / $\geq 8''$ for flange connections.

If you have a device with a double rod, double cable or coaxial probe, you can ignore these instructions.

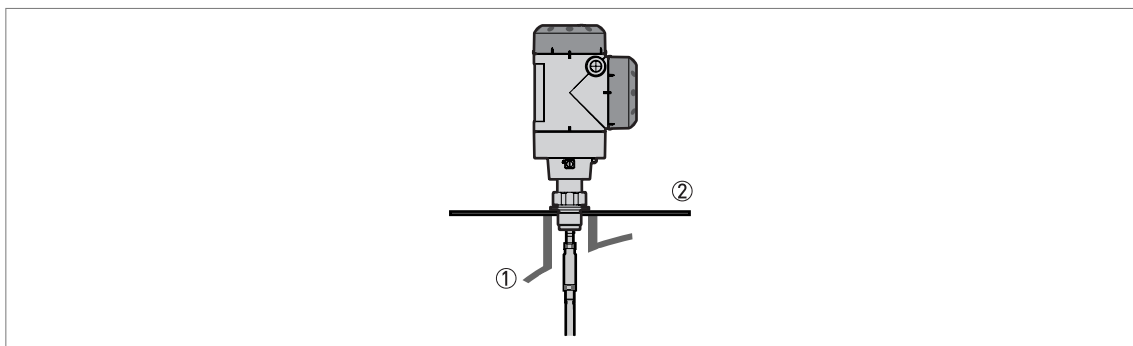

Figure 2-39: Installation in a non-metallic tank or pit with a thread connection

- ① Non-metallic (plastic etc.) tank or pit
- ② Metal sheet, $\varnothing \geq 200$ mm / 8"



CAUTION!

When the device is installed, make sure that the tank roof has no deformation.

2.10.10 Wall support for the remote version

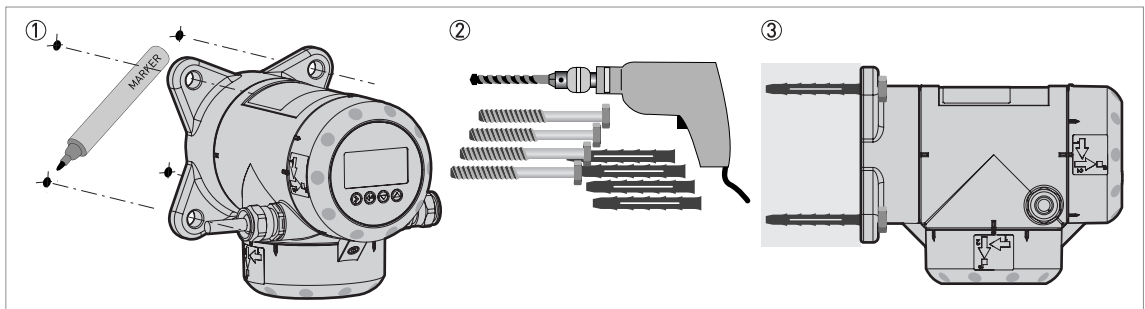

Figure 2-40: Wall support for the remote version (attached to the remote converter)



- ① Use marks on the wall to help you put the wall support in the correct position. For more data, refer to "Dimensions and Weights" in the handbook.
- ② Use equipment and tools that agree with health and safety regulations and good engineering practice.
- ③ Make sure the wall support is correctly attached to the wall.

2.10.11 How to attach the weather protection to the device

The device and the weather protection option are supplied disassembled in the same box. The weather protection can also be supplied as an accessory. You must attach the weather protection when you install the device.

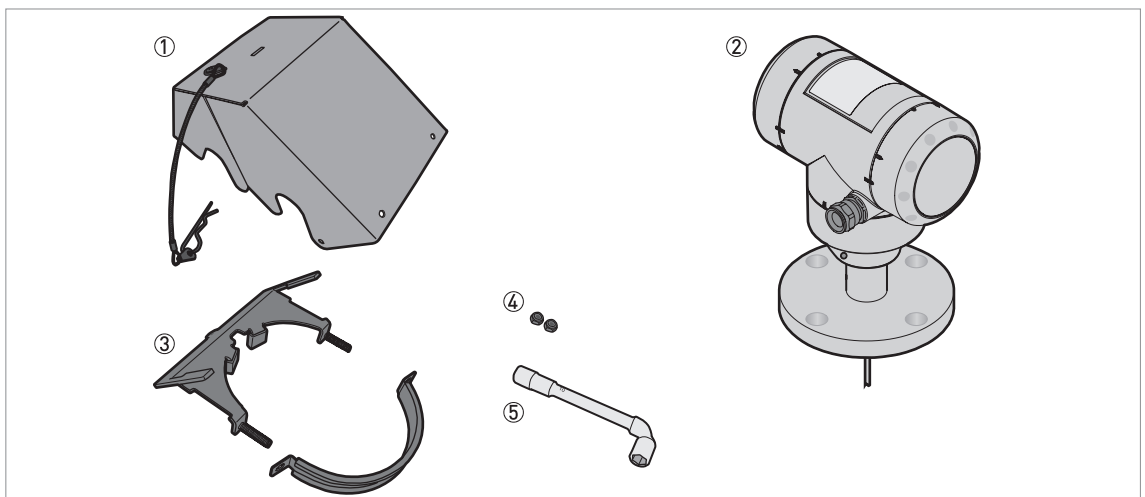

Figure 2-41: Equipment needed

- ① Weather protection cover (with an R-clip to hold the cover on the clamp)
- ② Device (with or without the optional display screen)
- ③ Weather protection clamp (2 parts)
- ④ 10 mm socket wrench (not supplied)
- ⑤ 2 locking nuts

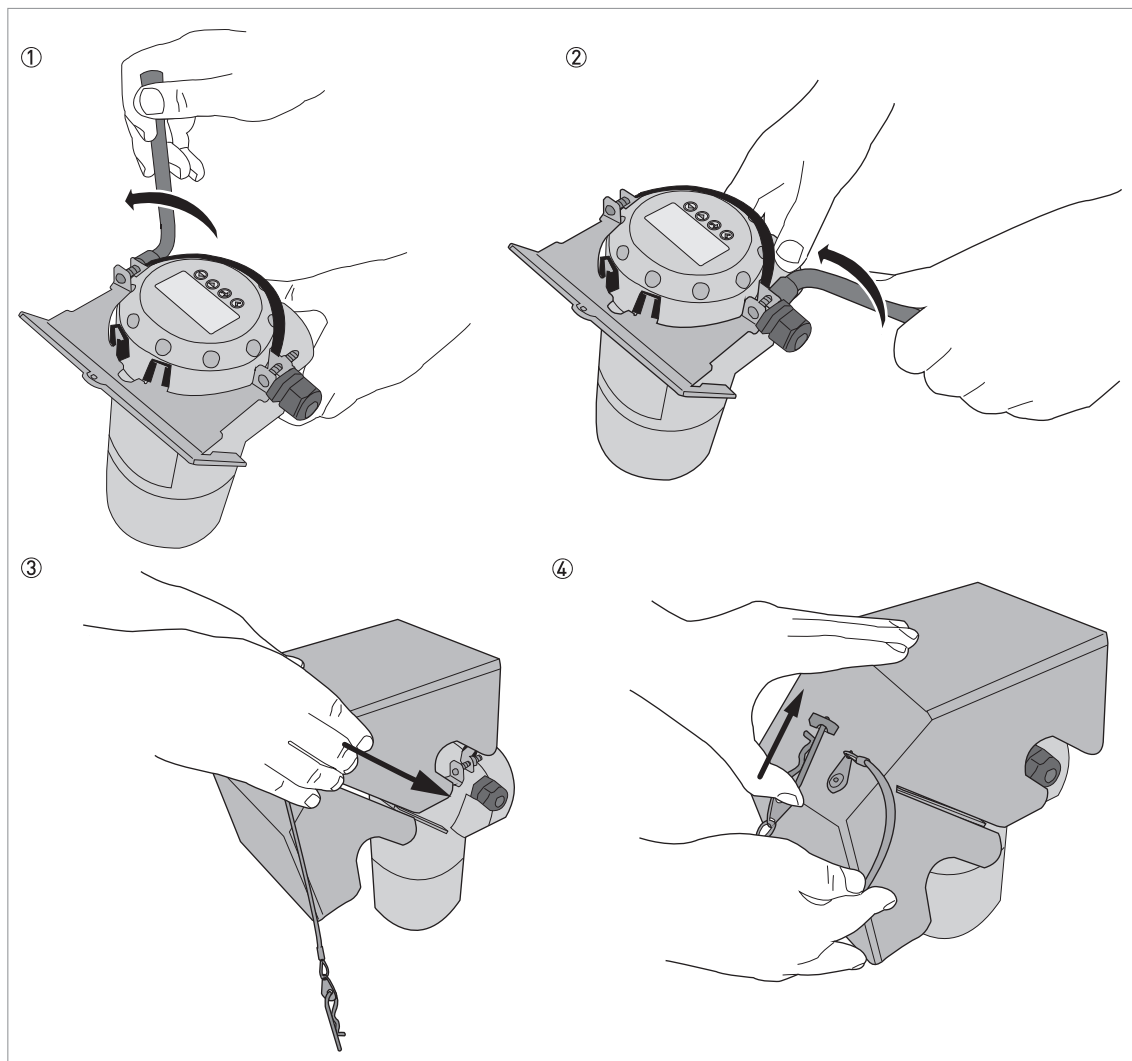

Figure 2-42: Installation of the weather protection on a vertical signal converter



INFORMATION!

Install the weather protection after you connect the device to the power supply.



- ① Put the weather protection clamp around the top of the device. Make sure that the locking nuts on the clamp are aligned with the cable entries.
- ② Attach the two locking nuts to the threads on the weather protection clamp. Tighten the locking nuts with a 10 mm socket wrench.
- ③ Lower the weather protection cover onto weather protection clamp until the hole for the lock is in the slot at the front of the cover.
- ④ Put the R-clip into the hole at the front of the weather protection cover.
- ➔ End of the procedure.

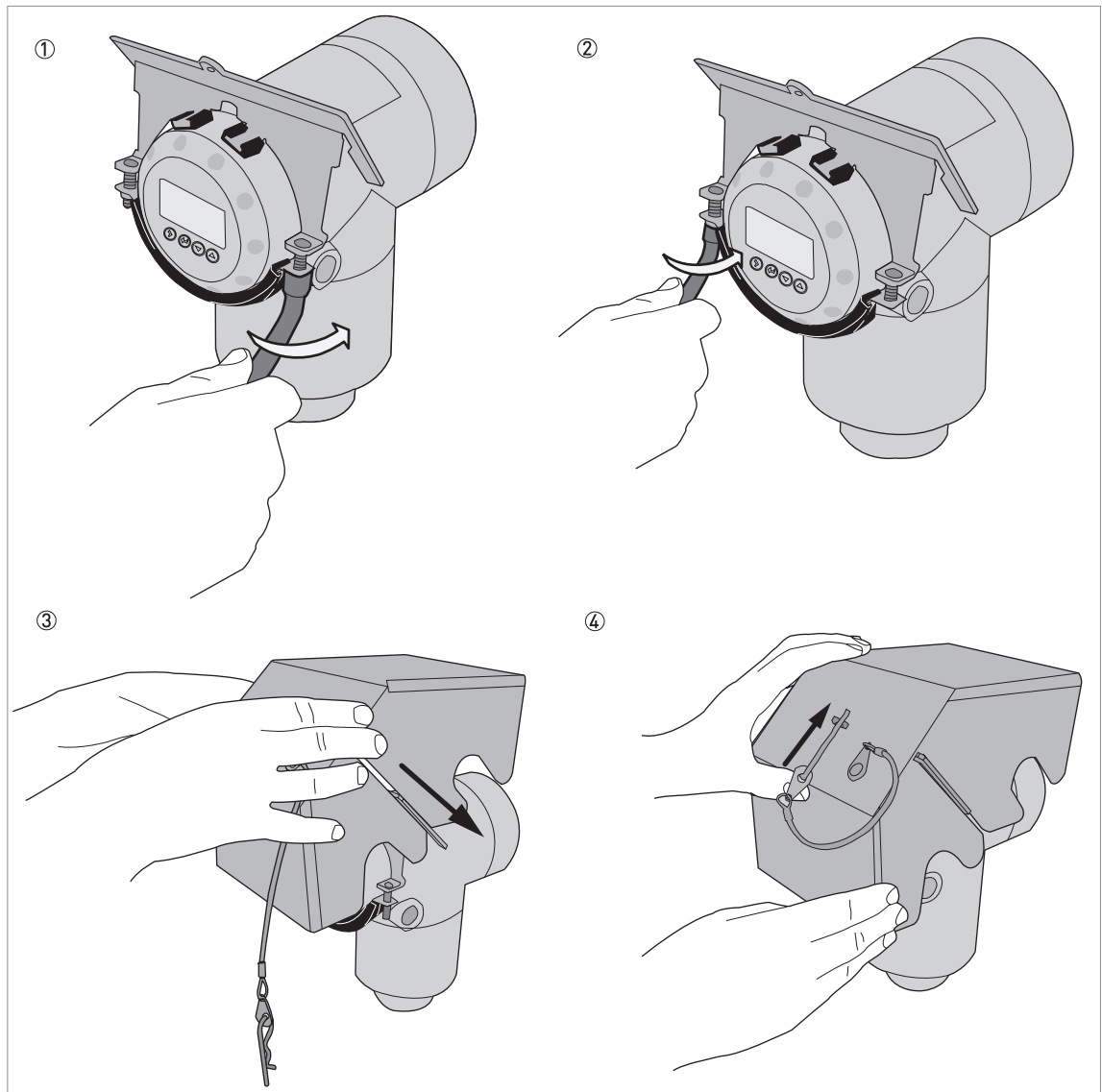

Figure 2-43: Installation of the weather protection on a horizontal signal converter



INFORMATION!

Install the weather protection after you connect the device to the power supply.



- ① Put the weather protection clamp around the front of the device (the end of the device that is nearest to the cable entry). Make sure that the locking nuts on the clamp are aligned with the cable entries.
- ② Attach the two locking nuts to the threads on the weather protection clamp. Tighten the locking nuts with a 10 mm socket wrench.
- ③ Lower the weather protection cover onto weather protection clamp until the hole for the lock is in the slot at the front of the cover.
- ④ Put the R-clip into the hole at the front of the weather protection cover.
- ➡ End of the procedure.

The overall dimensions of the weather protection are in "Dimensions and weights" in the handbook.

2.10.12 How to open the weather protection

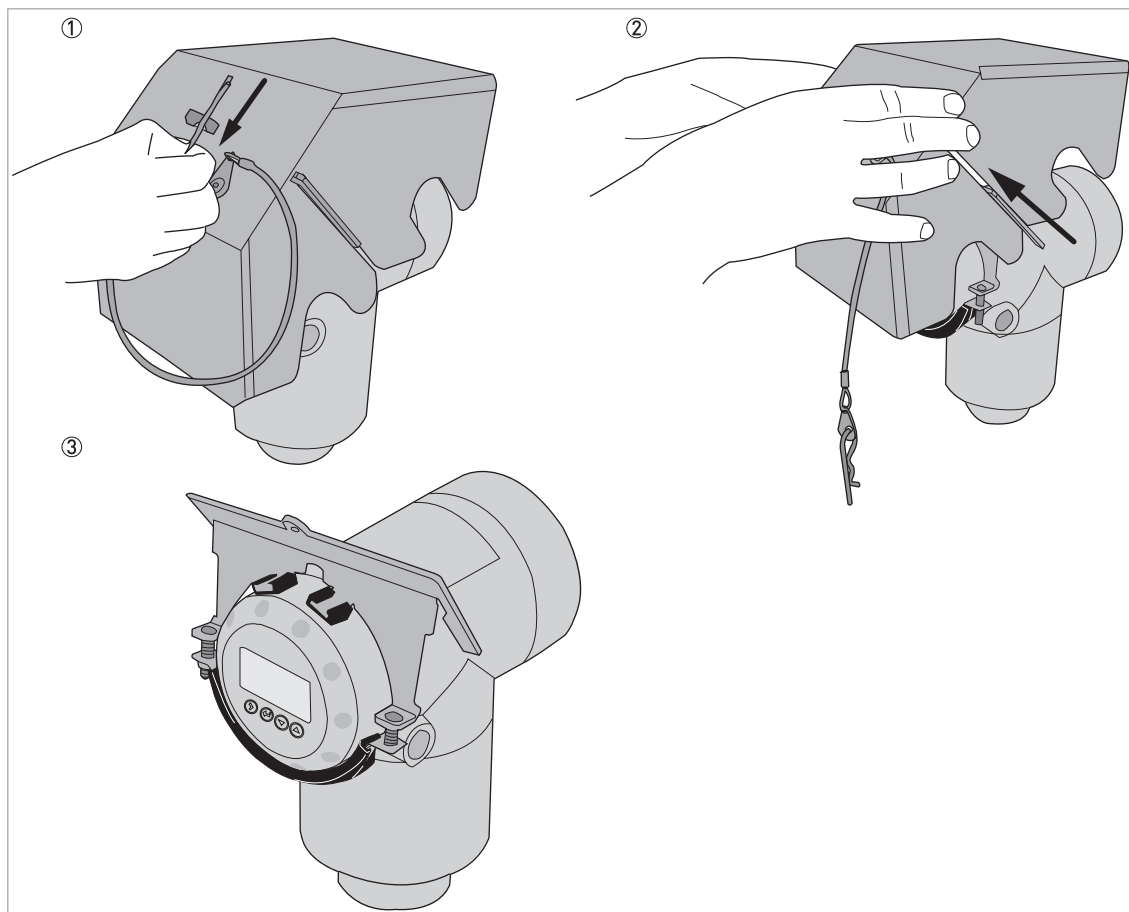

Figure 2-44: How to open the weather protection



INFORMATION!

Electrical installation: Remove the weather protection before you open the terminal compartment cover.



- ① Remove the R-clip from the hole at the front of the weather protection cover.
- ② Remove the weather protection cover.
- ➡ End of the procedure.

2.11 Electromagnetic compatibility

The device design agrees with the Electromagnetic Compatibility (EMC) Directive and the related European Standard when installed in metallic tanks.

You can install the device on open-air tanks and tanks that are not made of metal. Refer also to the note that follows.



CAUTION!

If you install a device with a rod or cable probe in a non-metallic tank or open-air pit, a strong electromagnetic field near to the device can have an unwanted effect on the accuracy. Use a device with a coaxial probe for this type of installation.

This device meets the essential requirements of the related European Standard:

- Emissions: class A and class B
- Immunity: basic, industrial and controlled environments



INFORMATION!

The device agrees with these conditions if:

- *the device has a single or double probe (rod or cable probe) and is used in a closed tank made of metal or*
- *the device has a coaxial probe.*

3.1 Electrical installation: 2-wire, loop-powered

3.1.1 Compact version

Terminals for electrical installation

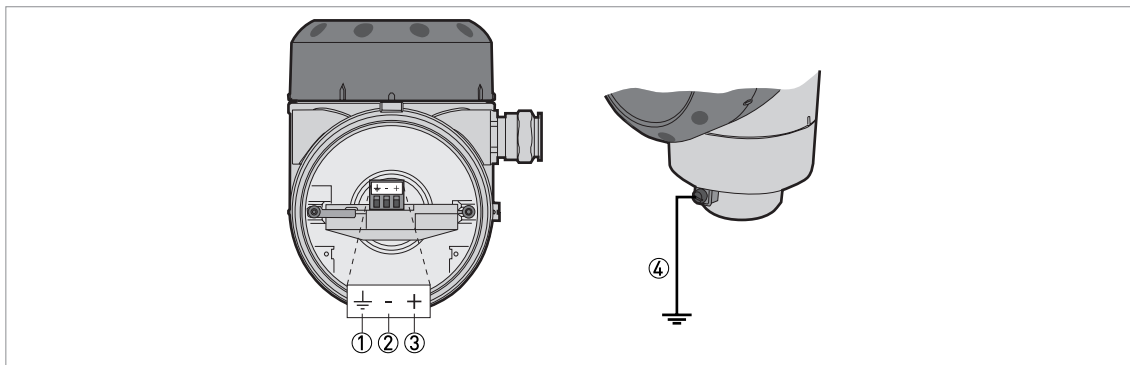

Figure 3-1: Terminals for electrical installation

- ① Grounding terminal in the housing (if the electrical cable is shielded)
- ② Current output -
- ③ Current output +
- ④ Location of the external grounding terminal (at the bottom of the converter)



INFORMATION!

Electrical power to the output terminal energizes the device. The output terminal is also used for HART® communication.



CAUTION!

- Use the applicable electrical cables with the cable glands.
- Make sure that the current is not more than 5 A or that there is 5 A-rated fuse in the electrical circuit that energizes the device.
- Make sure that the polarity of the power supply is correct. If the polarity is incorrect, you will not cause damage to the device but the device will not operate.

Open the terminal compartment cover

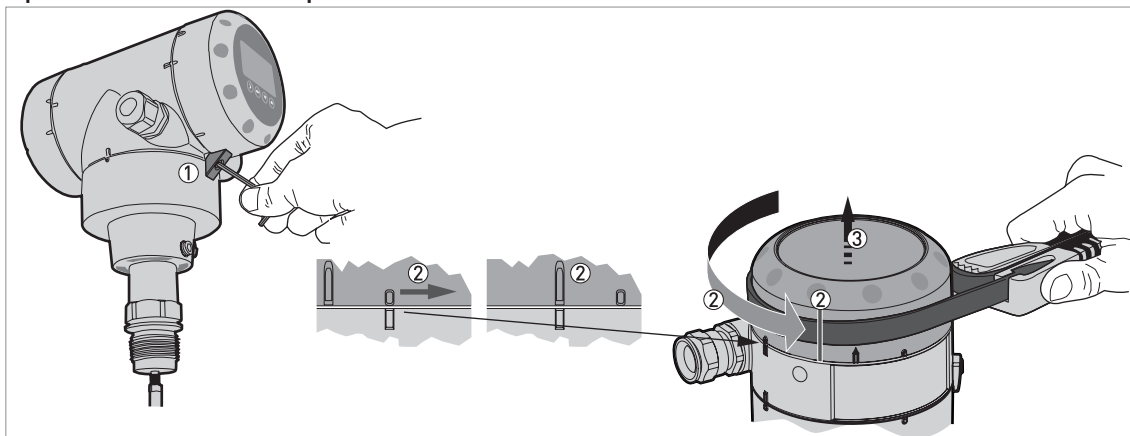

Figure 3-2: How to open the terminal compartment cover



- ① Loosen the lock screw with a 2.5 mm Allen wrench.
- ② Turn the cover counterclockwise with a strap wrench.

- ③ Remove the cover.

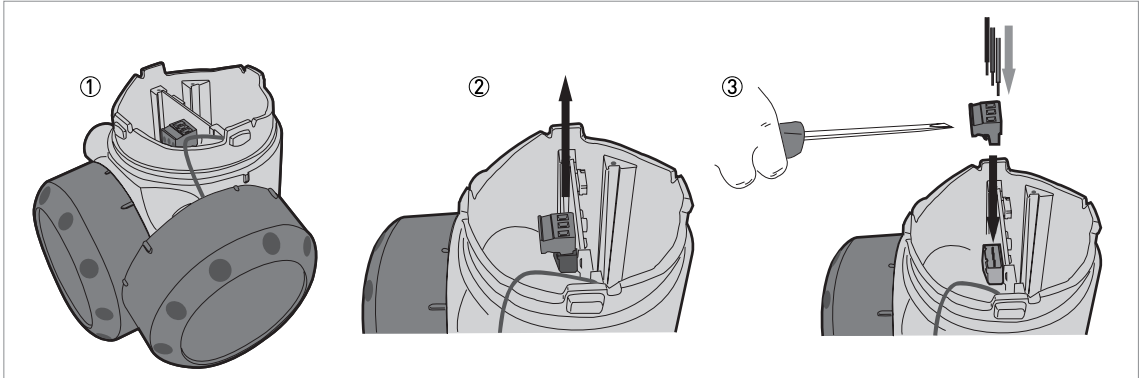

Figure 3-3: Procedure for electrical installation

Equipment needed:

- Small slotted tip screwdriver (not supplied)



Procedure:

- ① Do not disconnect the safety cord from the terminal compartment cover. Put the terminal compartment cover adjacent to the housing.
- ② Remove the connector from the circuit board.
- ③ Connect the electrical wires to the connector. Attach the connector to the circuit board. Tighten the cable entry glands.

Close the terminal compartment cover

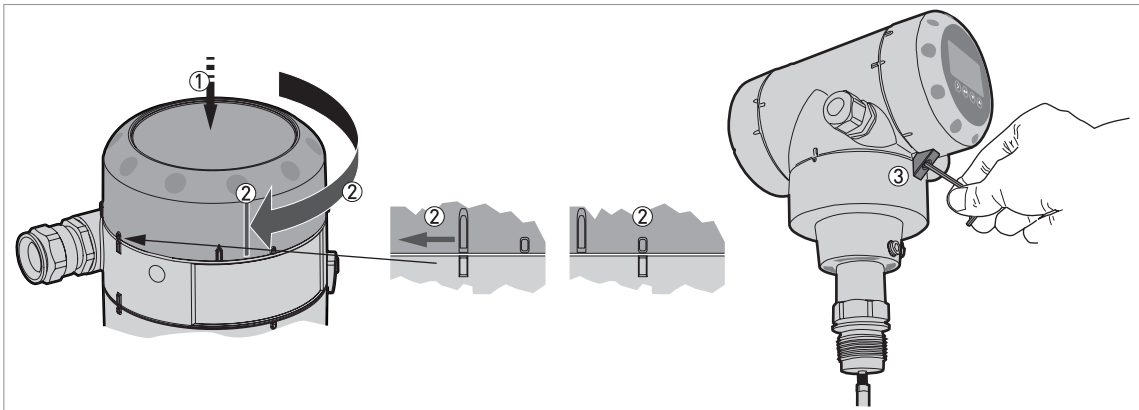

Figure 3-4: How to close the terminal compartment cover



- ① Put the cover on the housing and push it down.
- ② Turn the cover clockwise until it is fully engaged.
- ③ Tighten the lock screw.

3.1.2 Remote version

Terminals for electrical installation

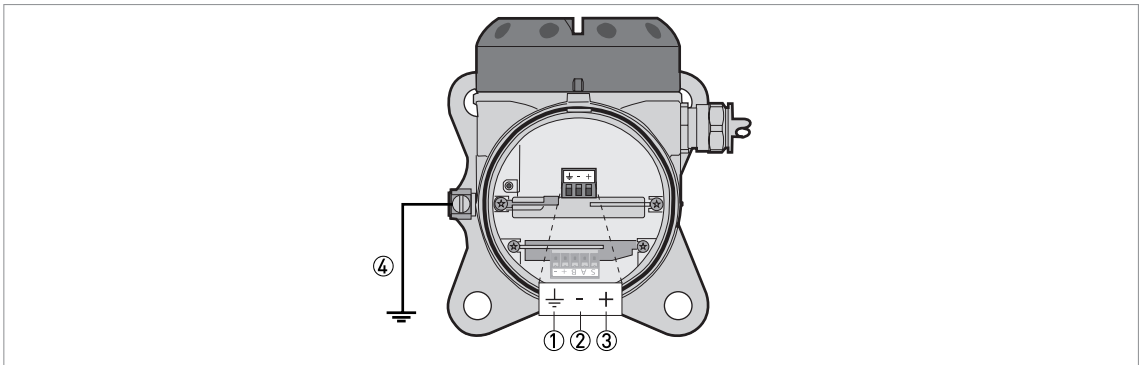

Figure 3-5: Terminals for electrical installation

- ① Grounding terminal in the housing (if the electrical cable is shielded)
- ② Current output -
- ③ Current output +
- ④ Location of the external grounding terminal (on the wall support)



INFORMATION!

Electrical power to the output terminal energizes the device. The output terminal is also used for HART® communication.



CAUTION!

- Use the applicable electrical cables with the cable glands.
- Make sure that the current is not more than 5 A or that there is 5 A-rated fuse in the electrical circuit that energizes the device.
- Make sure that the polarity of the power supply is correct. If the polarity is incorrect, you will not cause damage to the device but the device will not operate.

Connections between the remote converter and the probe housing

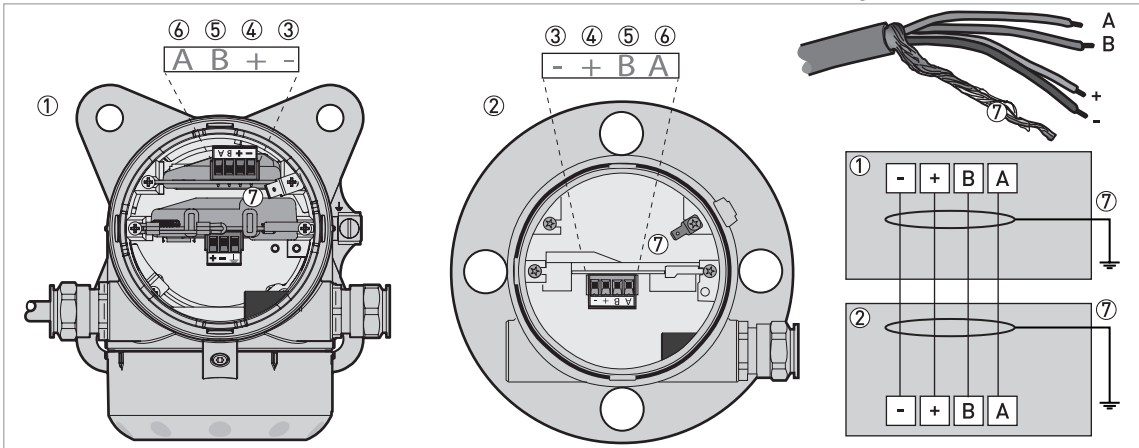

Figure 3-6: Connections between the remote converter and the probe housing

- ① Remote converter
- ② Probe housing
- ③ Power supply: voltage in -
- ④ Power supply: voltage in +
- ⑤ Signal cable B
- ⑥ Signal cable A
- ⑦ Shielding wire (attached to Faston connectors in the housings of the remote converter and the probe housing)

For more electrical installation data, refer to *Compact version* on page 42.

For more data about the signal cable between the remote converter and the probe housing, refer to the handbook.

3.2 Non-Ex devices

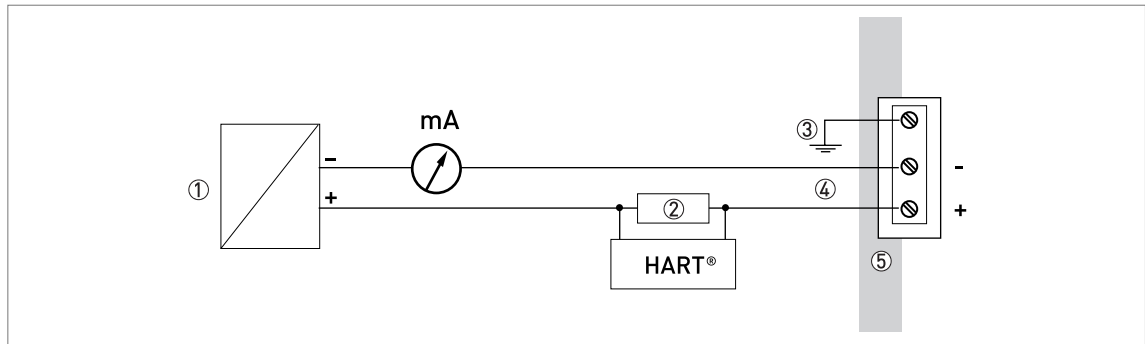

Figure 3-7: Electrical connections for non-Ex devices

- ① Power supply
- ② Resistor for HART® communication
- ③ Optional connection to the grounding terminal
- ④ Output: 11.5...30 VDC for an output of 22 mA at the terminal
- ⑤ Device

3.3 Devices for hazardous locations



DANGER!

For electrical data for device operation in hazardous locations, refer to the related certificates of compliance and supplementary instructions (ATEX, IECEx, etc.). You can find this documentation on the DVD-ROM delivered with the device or it can be downloaded free of charge from the website (*Download Center*).

3.4 Minimum power supply voltage

Use these graphs to find the minimum power supply voltage for a given current output load.

Non-Ex and Hazardous Location approved (Ex i / IS) devices



Figure 3-8: Minimum power supply voltage for an output of 22 mA at the terminal (Non-Ex and Hazardous Location approval (Ex i / IS))

X: Power supply U [VDC]
 Y: Current output load R_L [Ω]

Hazardous Location (Ex d / XP/NI) approved devices

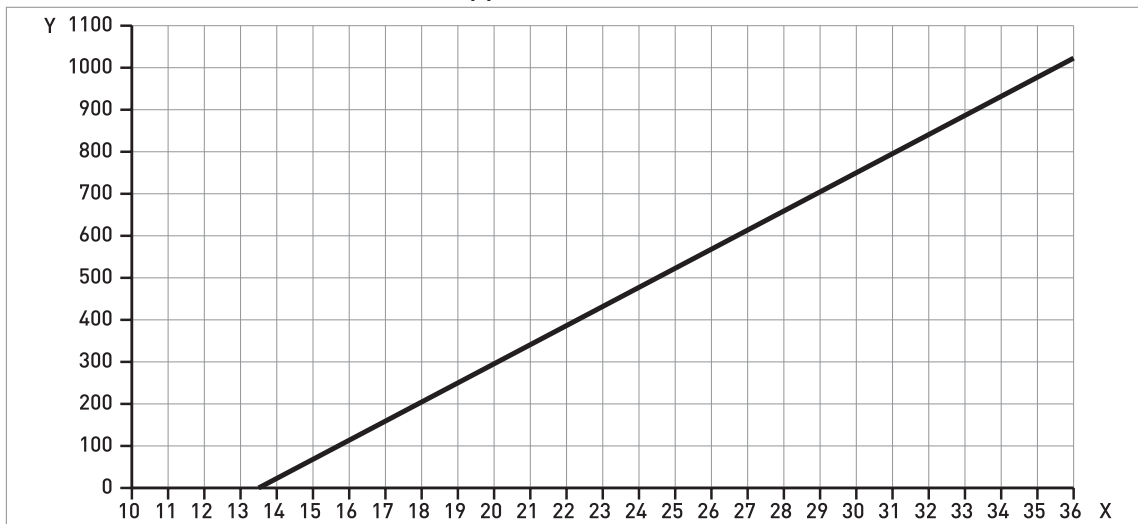

Figure 3-9: Minimum power supply voltage for an output of 22 mA at the terminal (Hazardous Location approval (Ex d / XP/NI))

X: Power supply U [VDC]
 Y: Current output load R_L [Ω]

3.5 Protection category



INFORMATION!

The device fulfils all requirements per protection category IP66 / IP67. It also fulfils all requirements per NEMA type 4X (housing) and type 6P (probe).



DANGER!

Make sure that the cable gland is watertight.

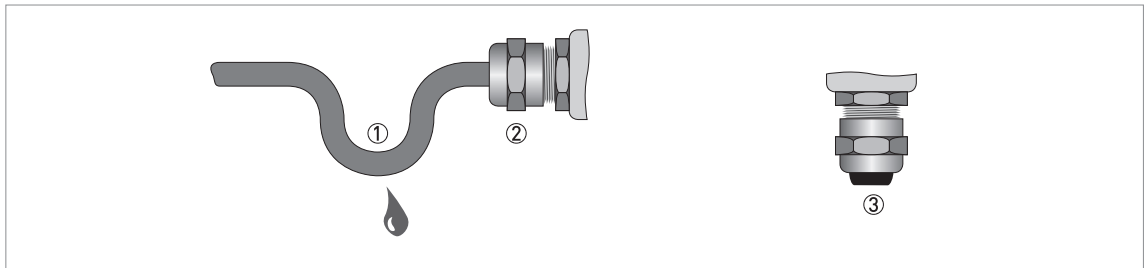

Figure 3-10: How to make the installation agree with protection category IP67



- Make sure that the gaskets are not damaged.
- Make sure that the electrical cables are not damaged.
- Make sure that the electrical cables agree with the national electrical code.
- The cables are in a loop in front of the device ① so water does not go into the housing.
- Tighten the cable feedthroughs ②.
- Close unused cable feedthroughs with dummy plugs ③.

Refer to the table that follows for the diameter of the outer sheath of the electrical cable:

Min. / Max. diameter of the electrical cable

Type of electrical cable	Approval	Min. / Max. diameter of the electrical cable	
		[mm]	[inches]
Power supply / output	non-Ex / Ex i	6...7.5	0.24...0.3
Power supply / output	Exd	6...10	0.24...0.39
Signal cable (for the remote version) ①	non-Ex / Ex i / Ex d	6...10	0.24...0.39

① This electrical cable is connected between the remote converter and the probe housing

3.6 Networks

3.6.1 General information

The device uses the HART® communication protocol. This protocol agrees with the HART® Communication Foundation standard. The device can be connected point-to-point. It can also have a polling address of 1 to 63 in a multi-drop network.

The device output is factory-set to communicate point-to-point. To change the communication mode from **point-to-point** to **multi-drop**, refer to "Network configuration" in the handbook.

3.6.2 Point-to-point networks

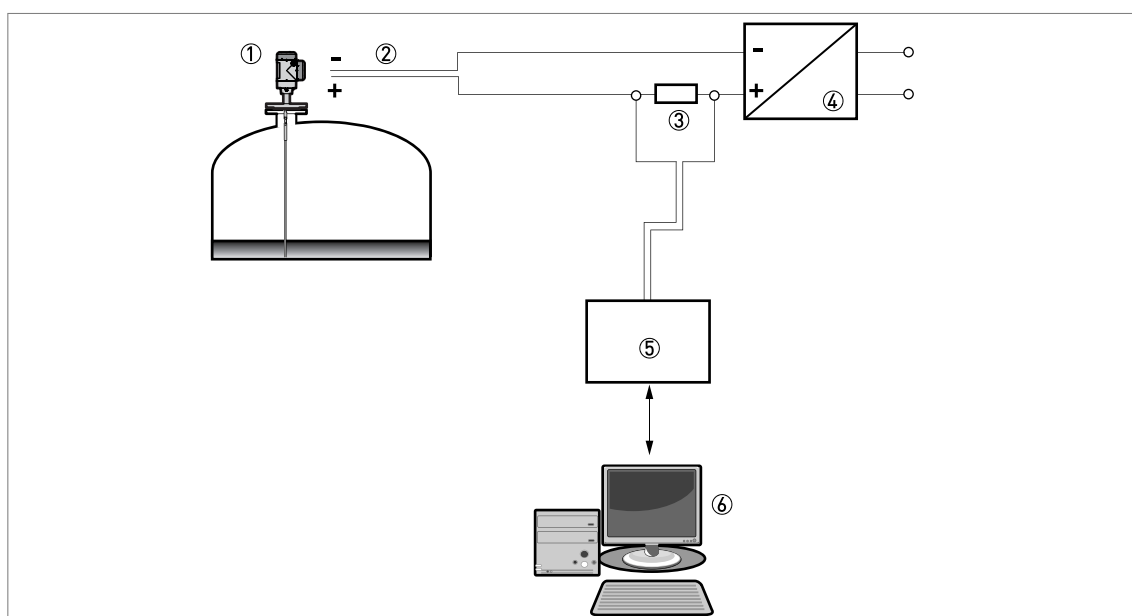

Figure 3-11: Point-to-point connection (non-Ex)

- ① Address of the device (0 for a point-to-point connection)
- ② 4...20 mA + HART®
- ③ Resistor for HART® communication
- ④ Power supply
- ⑤ HART® modem
- ⑥ HART® communication device

3.6.3 Multi-drop networks

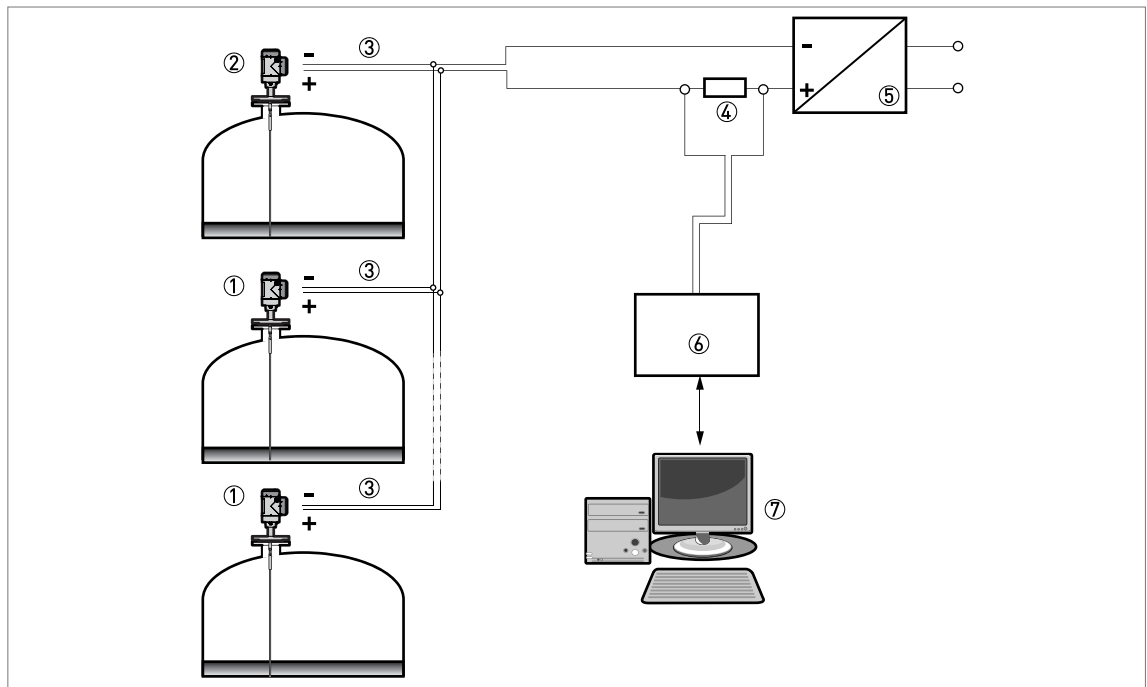

Figure 3-12: Multi-drop network (non-Ex)

- ① Address of the device (n+1 for multidrop networks)
- ② Address of the device (1 for multidrop networks)
- ③ 4 mA + HART®
- ④ Resistor for HART® communication
- ⑤ Power supply
- ⑥ HART® modem
- ⑦ HART® communication device

3.6.4 Fieldbus networks

For more data, refer to the supplementary instructions for FOUNDATION™ fieldbus and PROFIBUS PA.

FOUNDATION™ fieldbus network (non-Ex)

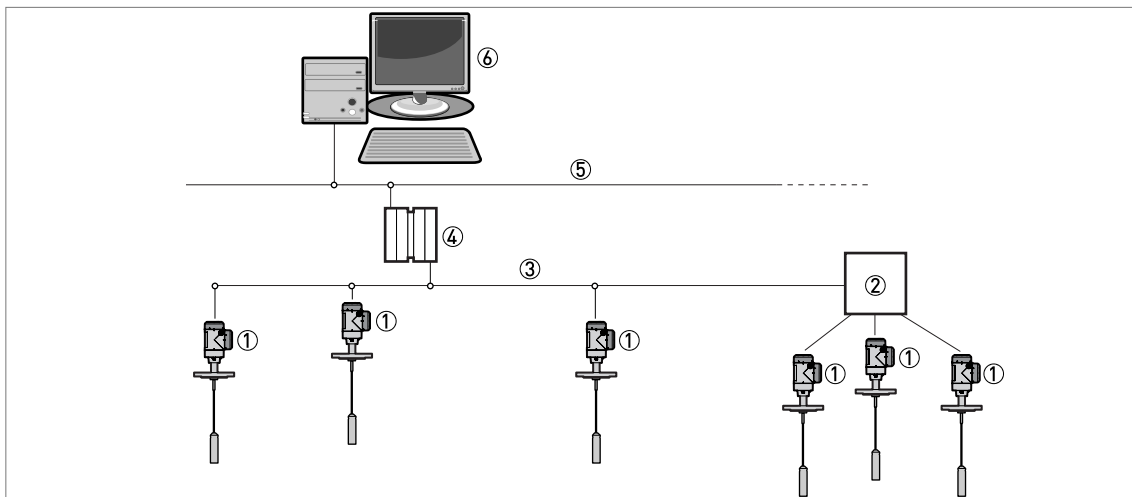

Figure 3-13: FOUNDATION™ fieldbus network (non-Ex)

- ① Field device
- ② Junction box
- ③ H1 network
- ④ H1/HSE converter
- ⑤ High Speed Ethernet (HSE)
- ⑥ Workstation

PROFIBUS PA/DP network (non-Ex)

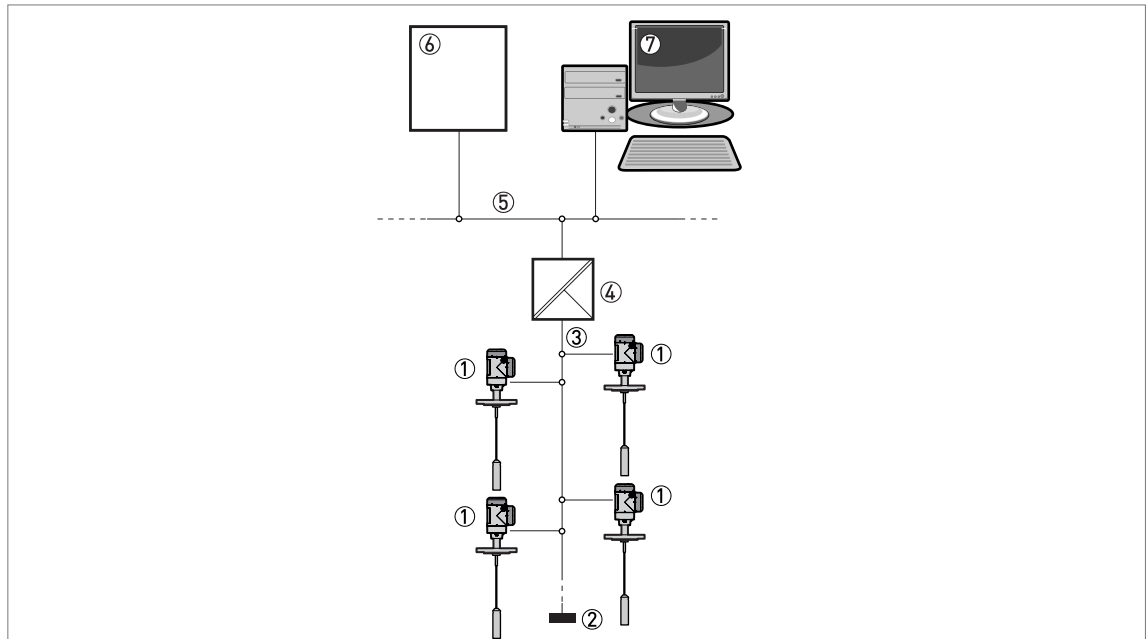

Figure 3-14: PROFIBUS PA/DP network (non-Ex)

- ① Field device
- ② Bus termination
- ③ PROFIBUS PA bus segment
- ④ Segment coupler (PA/DP link)
- ⑤ PROFIBUS DP bus line
- ⑥ Control system (PLC / Class 1 master device)
- ⑦ Engineering or operator workstation (Control tool / Class 2 master device)

4.1 General notes

For more data about device configuration, refer to the handbook.

4.2 Digital display screen

4.2.1 Local display screen layout

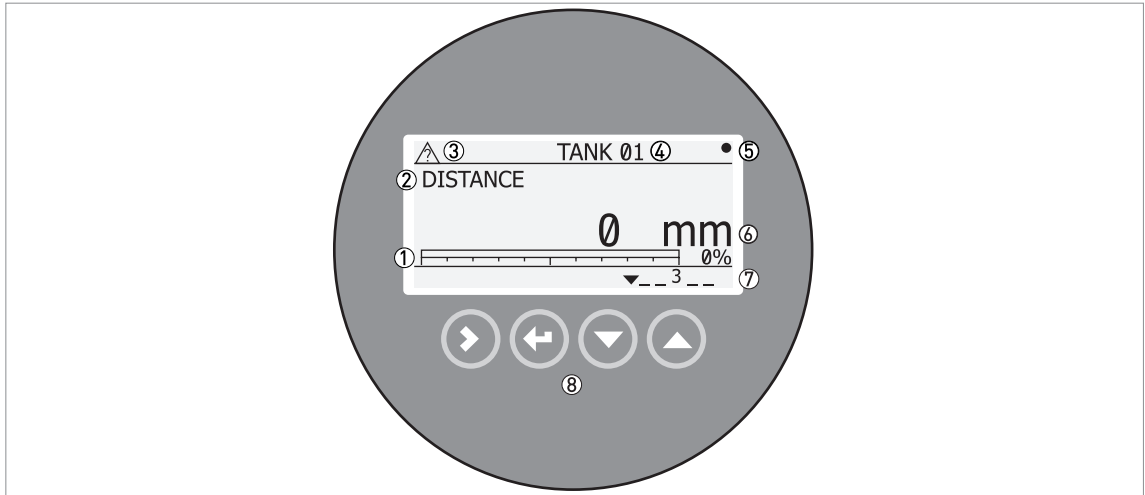

Figure 4-1: Local display screen layout in Normal mode

- ① Current output percentage (bar graph and text — only shown if the current output function is the same as the measurement on the screen in normal mode)
- ② Measurement type (in this example, distance)
- ③ Device status (NE 107 symbols)
- ④ Device tag name
- ⑤ Updated measurement data symbol (the symbol flashes each time the measurement data is updated)
- ⑥ Measurement value and units
- ⑦ Device status (markers)
- ⑧ Keypad buttons (refer to the table in the section that follows)

4.2.2 Functions of keypad buttons

Keypad button	Function
[Right]	Normal mode: Enter Information menu (Enter Configuration mode) Configuration mode: Move cursor to the right
[Return / Escape]	Normal mode: Change units (m, cm, mm, in, ft) Configuration mode: Exit
[Down]	Normal mode: Change measurement type (distance, level, output (%), output (mA), conversion, ullage conversion) ① Configuration mode: Decrease value or change parameter
[Up]	Normal mode: Change measurement type (distance, level, output (%), output (mA), conversion, ullage conversion) ① Configuration mode: Increase value or change parameter

① If you have made a strapping table in menu item 2.8.1 INPUT TABLE for volume or mass measurement, "Conversion" and "Ullage Conv." will be shown in the list of measurement types

For data on keypad functions, refer to the **Operation** section in the handbook.

4.3 Commissioning

Use this procedure to change the probe length and give the top and bottom measuring limits. Values and parameters that can be changed are shown between « ... » in the illustrations that follow. Push the keypad buttons in the correct sequence:







CAUTION!

Make sure that you do this procedure before you use the device. The settings in this procedure have an effect on the performance of the device.

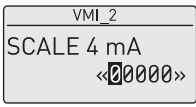
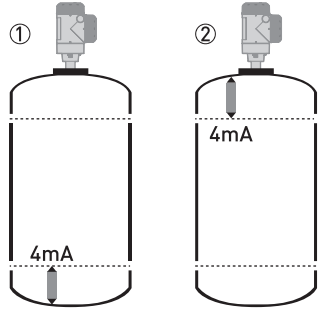
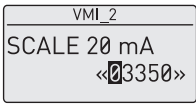
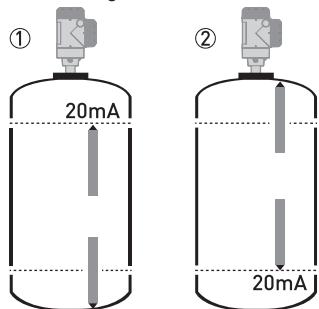
Procedure

Screen	Steps	Description
	<ul style="list-style-type: none"> [>], [▲] and [>]. 	Default screen. Enter configuration mode (2.0.0 SUPERVISOR).
	<ul style="list-style-type: none"> [>], [←], [▼], [▲], [>] and [←]. 	Enter the password (the default password is shown). If it is necessary to change the password, refer to the handbook.
	<ul style="list-style-type: none"> [>] and [>] 	Push this button 2 times to start the commissioning procedure.
	<ul style="list-style-type: none"> [>] to change the tank height (H). [>] to change the position of the cursor. [▼] to decrease the value or [▲] to increase the value. [←] to confirm. 	
	<ul style="list-style-type: none"> [▲] or [▼] for the selection of the measurement name (Distance, Level, Conversion or Ullage Conv.). [←] to confirm. 	The manufacturer sets the output function to "Level" before delivery. If it is necessary to measure volume, ullage volume, mass or ullage mass (Conversion or Ullage Conv.), refer to the handbook.
	<ul style="list-style-type: none"> [▲] or [▼] for the selection of the current output range (4-20 mA/3.6E, 4-20, 3.8-20.5/3.6E, etc.). [←] to confirm. 	

Screen	Steps	Description
	<ul style="list-style-type: none"> • [>] to change Scale 4 mA. • [>] to change the position of the cursor. • [▼] to decrease the value or [▲] to increase the value. • [←] to confirm. 	<p>Use this step to give the 4 mA output setting (0% limit) in the tank. Refer to the illustrations that follow. Illustration ① shows the settings for level. Illustration ② shows the settings for distance.</p> 
	<ul style="list-style-type: none"> • [>] to change Scale 20 mA. • [>] to change the position of the cursor. • [▼] to decrease the value or [▲] to increase the value. • [←] to confirm. 	<p>Use this step to give the 20 mA output setting (100% limit) in the tank. Refer to the illustrations that follow. Illustration ① shows the settings for level. Illustration ② shows the settings for distance.</p> 
	<ul style="list-style-type: none"> • [▲] or [▼] for the selection of the error delay (0 s, 10 s, 20 s, 30 s, 1 mn, 2 mn, 5 mn or 15 mn). • [←] to confirm. 	<p>The time after which the current output changes to an error value. The error value shows that there is a measurement error.</p>
	<ul style="list-style-type: none"> • [>] to change the tag name. • [>] to change the position of the cursor. • [▼] to decrease the alphanumeric value (A, B, etc. / 1, 2, etc.) or [▲] to increase the alphanumeric value. • [←] to confirm. 	
	<ul style="list-style-type: none"> • 3 × [←] to confirm. • [▲] or [▼] for the selection of the save option (STORE NO or STORE YES). • [←] to confirm. 	<p>Set to STORE YES to save and use the data. Set to STORE NO to cancel the changes to the device settings.</p>

4.4 Probe length calculation



CAUTION!

- Make sure that you do this procedure before you use the device.
- If you decrease the probe length, do the probe length calculation procedure before the snapshot procedure.
- The probe length cannot be less than 600 mm / 23.6" for coaxial probes and 1000 mm / 39.4" for other probe types.
- Make sure that the tank is empty or only filled to the minimum level.
- Make sure that there are no objects adjacent to the probe. For more data about empty space, refer to General requirements on page 16.

Do this quick set-up procedure (menu item 2.1.3) if:

- it is the first time that the device is used,
- the probe length was changed or
- the signal converter was replaced.

When you do this procedure, the device automatically calculates and records the probe length.

Values and parameters that can be changed are shown between the « ... » marks in the illustrations that follow. Push the keypad buttons in the correct sequence:

Procedure

Screen	Steps	Description
	<ul style="list-style-type: none"> • [>], [▲] and [>]. 	Default screen. Enter configuration mode (2.0.0 SUPERVISOR).
	<ul style="list-style-type: none"> • [>], [←], [▼], [▲], [>] and [←]. 	Enter the password (the default password is shown). If it is necessary to change the password, refer to the handbook.
	<ul style="list-style-type: none"> • [>], [▲], [▲] and [>] 	
	<ul style="list-style-type: none"> • [>] for the selection of "Partially filled" or [▲] for the selection of "Empty". 	Is your tank partially filled or empty? If the tank is partially filled, the procedure will not start.
		The device measures the new probe length. If the display screen shows the error message "Failure! Pulse Lost" then speak to the supplier.

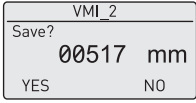
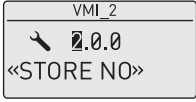
Screen	Steps	Description
	<ul style="list-style-type: none"> • [➤] for the selection of YES or [▲] for the selection of NO. 	The device shows the new probe length. Set to YES to save the data. Set to NO to erase the data.
	<ul style="list-style-type: none"> • 3 × [←] to confirm. • [▲] or [▼] for the selection of the save option (STORE NO or STORE YES). • [←] to confirm. 	Set to STORE YES to use the data. Set to STORE NO to cancel the changes to the device settings.

If the probe length calculated in this procedure is much shorter than the real probe length, then do the procedure that follows:



- Go to menu item 2.3.6 DETECT.DELAY in the supervisor menu.
- Record the initial value.
- Is the initial value the same as 2.3.2 BLOC. DIST.?
- If the initial value is different, change the value to the blocking distance in menu item 2.3.2 BLOC. DIST..
- Do the probe length calculation procedure again.
- After you complete the procedure, change the value back to its initial setting.

For more data about menu items, refer to the handbook.

4.5 Snapshot

The snapshot procedure is very important for the performance of the device. Make sure that the tank is empty or only filled to the minimum level before you do the procedure.

Use this procedure (menu item 2.1.2) if there are objects adjacent to the probe that can cause parasitic signals. The device does a scan for objects that do not change their vertical positions in the tank (heating tubes, agitators, fuel assemblies etc.) and records the data. The device can then use this data to put the measurement signal through a filter (Dynamic Parasite Rejection).



INFORMATION!

Dynamic Parasite Rejection (DPR) is a function that automatically puts parasitic signals through a signal filter. Parasitic signals are caused by internal vessel installations or build-up on the probe during normal operation. Use the DPR function to get the best possible performance during level measurement. To use the device with the DPR function, do the snapshot procedure (refer to menu item 2.1.2). During this procedure, the software finds, marks, and saves all parasitic signals.

When the device is in DPR mode (when menu item 2.5.11 SNAPSHOT MOD. is set to "static" or "static and dynamic"), it will automatically update this data to ignore old and new parasitic signals. Thus, it is not necessary to do the snapshot procedure again. Because the device records the data from the SNAPSHOT procedure (for "static" or "static and dynamic" modes), it is also not necessary to do the procedure again if you de-energize the device.



CAUTION!

- If you decrease the probe length, do the probe length calculation procedure before the snapshot procedure.
- Make sure that the tank is empty or only filled to the minimum level.
- Make sure that there are no objects adjacent to the probe. For more data about empty space, refer to General requirements on page 16.

Before you do the snapshot procedure, install the device on the tank. For more data about how to install the device, refer to the handbook.

Values and parameters that can be changed are shown between the « ... » marks in the illustrations that follow. Push the keypad buttons in the correct sequence:

Procedure

Screen	Steps	Description
	<ul style="list-style-type: none"> • [>], [▲] and [>]. 	Default screen. Enter configuration mode (2.0.0 SUPERVISOR).
	<ul style="list-style-type: none"> • [>], [←], [▼], [▲], [>] and [←]. 	Enter the password (the default password is shown). If it is necessary to change the password, refer to the handbook.

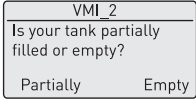
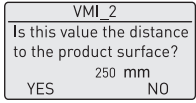
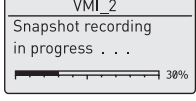
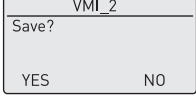
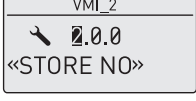
Screen	Steps	Description
	<ul style="list-style-type: none"> [>], [▲] and [▶] 	Push these buttons to start the snapshot procedure.
	<ul style="list-style-type: none"> [>] for the selection of "Partially filled" or [▲] for the selection of "Empty". 	Is your tank partially filled or empty? If the tank is partially filled, the device will scan for the first reflection in the tank. Continue to the subsequent step. NOTE: If you set this step to "Partially filled", but the tank is empty, the device will show the error message "Failure! Pulse Lost". Push one of the keypad buttons to go back to the start of the Snapshot procedure. If the tank is empty, the scan will start immediately. Ignore the 2 subsequent steps.
	<ul style="list-style-type: none"> [>] for the selection of YES or [▲] for the selection of NO. 	The device shows the distance to the surface of the tank contents. Set to YES if the distance is correct. The scan will start immediately. Set to NO if the distance is incorrect. The scan will start immediately, but the device will ignore the reflection found at this distance from the device.
		The device does a scan for objects that do not change their vertical positions in the tank (heating tubes, agitators, fuel assemblies etc.) and records the data.
	<ul style="list-style-type: none"> [>] for the selection of YES or [▲] for the selection of NO. 	The device completes the scan. Set to YES to save the data. Set to NO to erase the data.
	<ul style="list-style-type: none"> 3 × [←] to confirm. [▲] or [▼] for the selection of the save option (STORE NO or STORE YES). [←] to confirm. 	Set to STORE YES to use the data. Set to STORE NO to cancel the changes to the device settings.





KROHNE – Process instrumentation and measurement solutions

- Flow
- Level
- Temperature
- Pressure
- Process Analysis
- Services

Head Office KROHNE Messtechnik GmbH
Ludwig-Krohne-Str. 5
47058 Duisburg (Germany)
Tel.: +49 203 301 0
Fax: +49 203 301 10389
info@krohne.com

The current list of all KROHNE contacts and addresses can be found at:
www.krohne.com

KROHNE