



## OPTIFLUX 2070 Quick Start

Battery powered electromagnetic flowmeter

**KROHNE**

## General safety notes

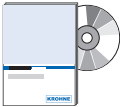

You can find the newest and/or additional information on the CD-ROM provided, in the handbook, the datasheet, special manuals, certificates and the download center at [www.krohne.com](http://www.krohne.com).



Installation, mounting, commissioning, and maintenance can be performed only by trained personnel.



Responsibility for suitability and intended use of this instrument rests solely with the user.

The supplier accepts no liability for inappropriate use by the customer.

Improper installation and operation may lead to loss of warranty. Moreover, the "general terms and conditions" on the back of the bill apply, which form the basis for the sales contract.

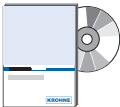

If you have to send the device back to the manufacturer or supplier, fill out the form contained on the CD-ROM and enclose it with the device. Unless this form is completely filled out, it will unfortunately not be possible for the manufacturer to perform repair or inspection.



Respect general and local electrical safety requirements.

## Visual check

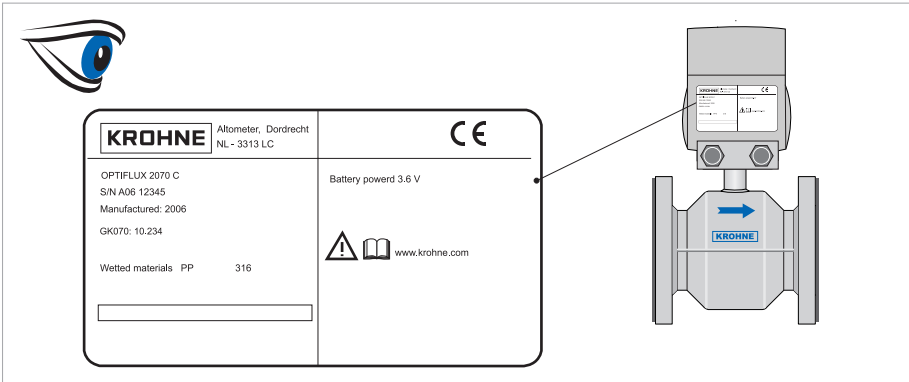

## Scope of delivery

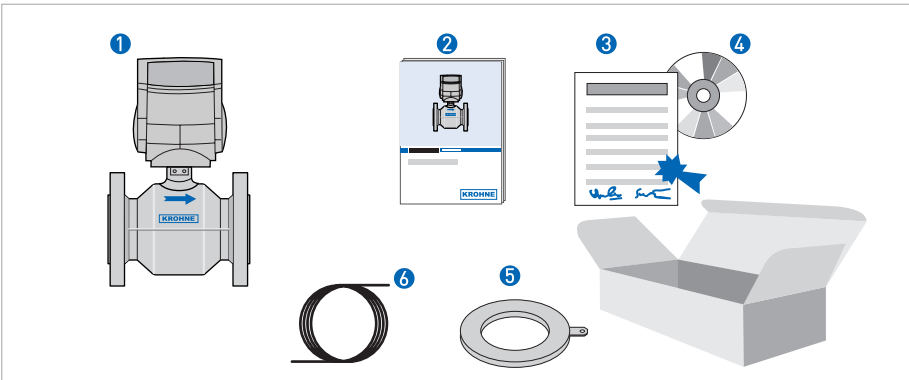

- 1 OPTIFLUX 2070 with blue protection cap
- 2 Quick Start
- 3 Factory calibration report
- 4 CD-ROM including Handbook, Quick Start, Technical datasheet
- 5 Grounding ring (optional)
- 6 Cable (remote version only)

## Transport

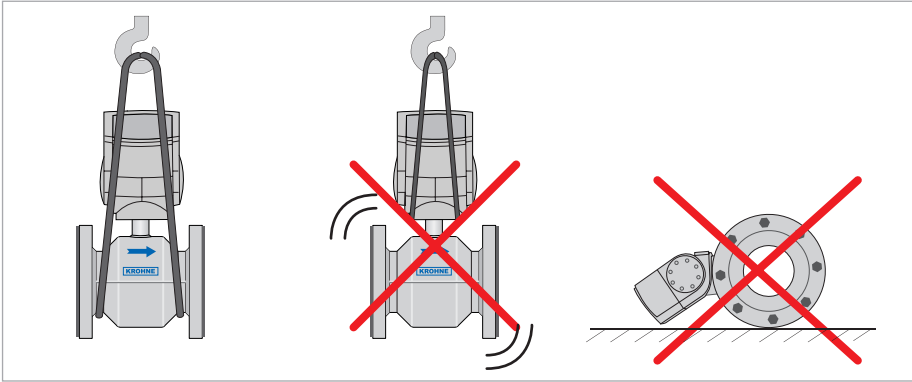

## Inlet and outlet

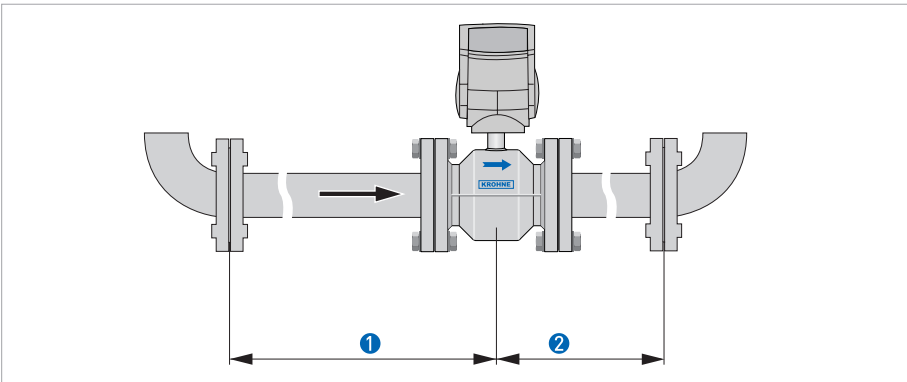

- ①  $\geq 5 \text{ DN}$
- ②  $\geq 2 \text{ DN}$

## Mounting position and flange deviation

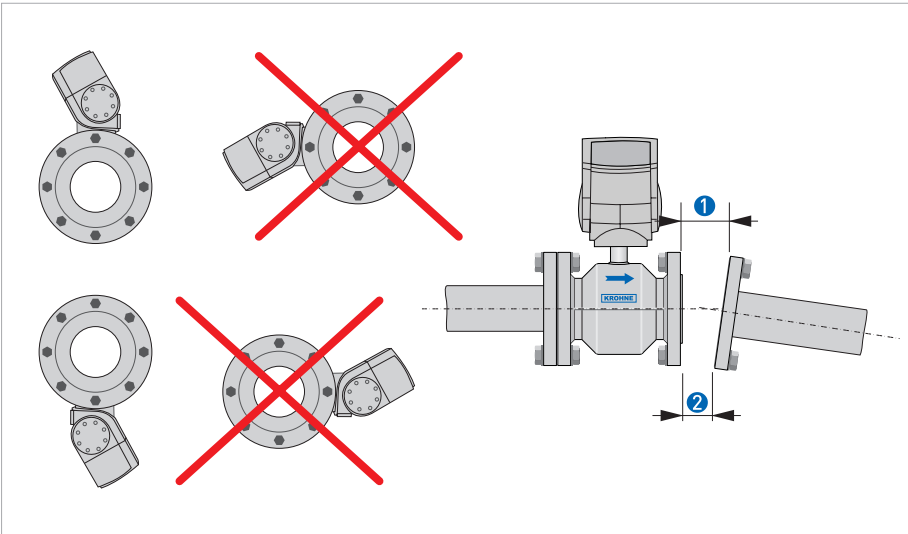

- ①  $L_{max}$
- ②  $L_{min}$



### **CAUTION!**

Max. permissible deviation of pipe flange faces:

$$L_{max} - L_{min} \leq 0.5 \text{ mm}$$

## Vibration

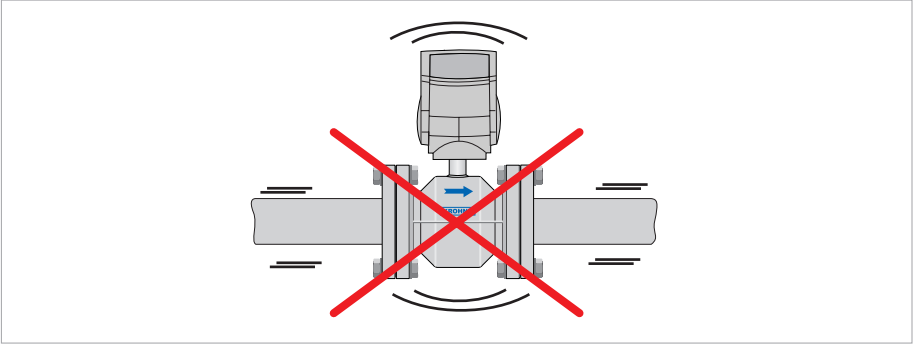

## Magnetic field

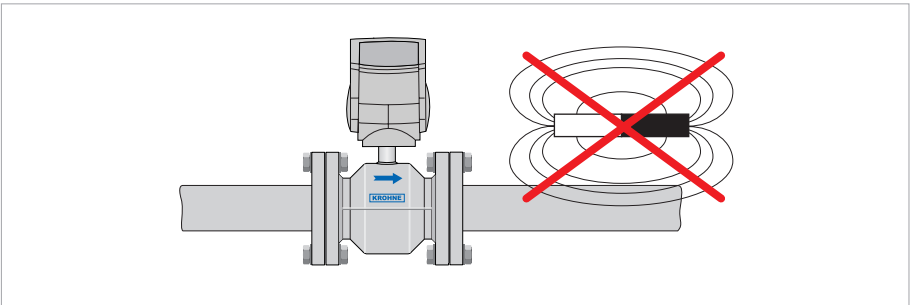

## Bends

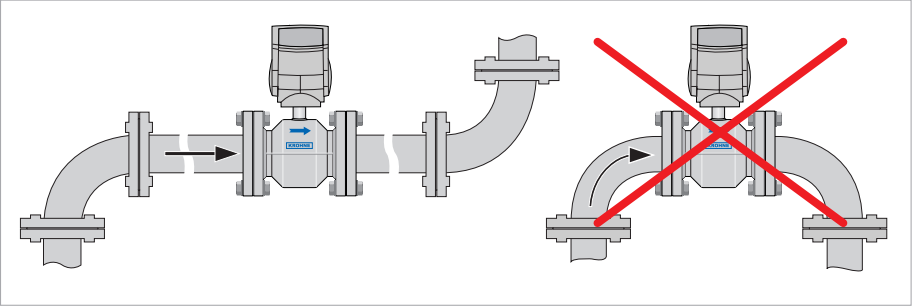

## Open discharge

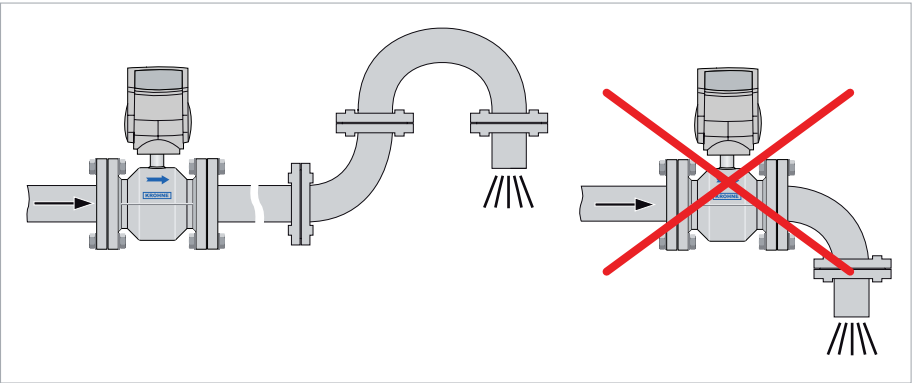

### T-section

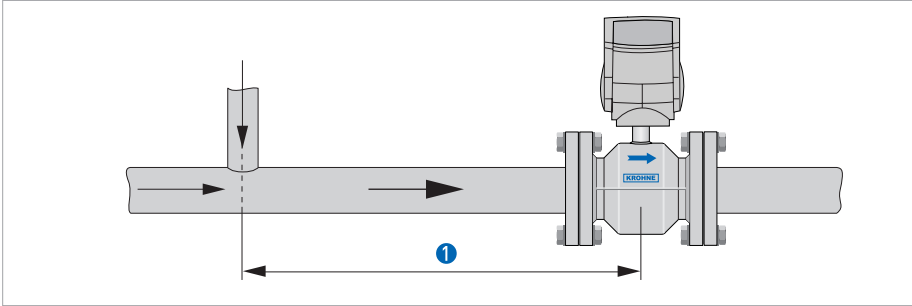

1  $\geq 10$  DN

### Control valve

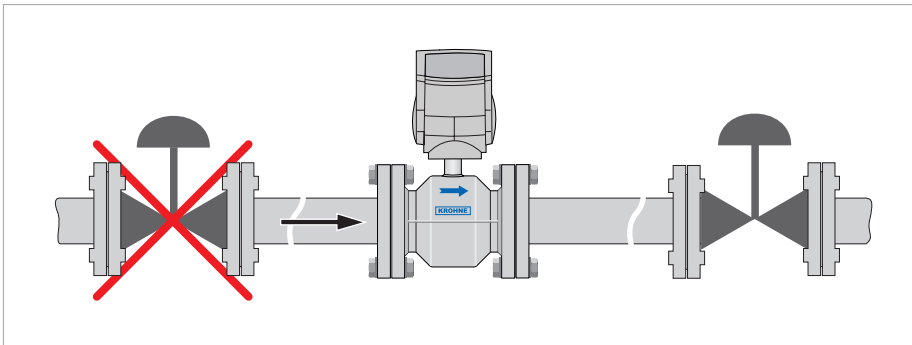



## Pump

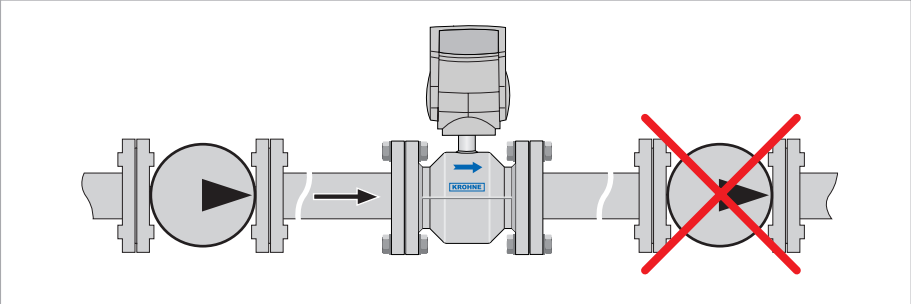

## Grounding

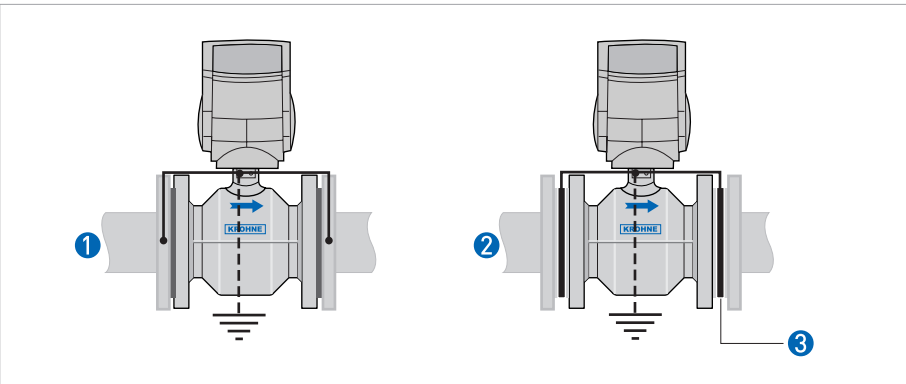

- 1 Metal pipelines, not internally coated. Grounding without grounding rings!
- 2 Metal pipelines with internal coating and non-conductive pipelines. Grounding with grounding rings!
- 3 Grounding rings



### CAUTION!

*The grounding of the flowmeter provides a stable and accurate measurement.*

## Torques and pressures

Nominal size DN[mm]	Pressure rating	Bolts	Max. torque [Nm]	
			Polypropylene	Hardrubber
50	PN 40	4 × M 16	55	31
65	PN 16	4 × M 16	51	42
65	PN 40	8 × M 16	38	21
80	PN 40	8 × M 16	47	25
100	PN 16	8 × M 16	39	30
125	PN 16	8 × M 16	53	40
150	PN 16	8 × M 20	68	47
200	PN 10	8 × M 20	-	68
200	PN 16	12 × M 20	-	45
250	PN 10	12 × M 20	-	65
250	PN 16	12 × M 24	-	78
300	PN 10	12 × M 20	-	76
300	PN 16	12 × M 24	-	105
350	PN 10	16 × M 20	-	75
400	PN 10	16 × M 24	-	104
450	PN 10	20 × M 24	-	93
500	PN 10	20 × M 24	-	107
600	PN 10	20 × M 27	-	138

Nominal size [inch]	Flange class [lbs]	Bolts	Max. torque [Nm]	
			Polypropylene	Hardrubber
2	150	4 × 5/8"	24	23
3	150	4 × 5/8"	43	39
4	150	8 × 5/8"	34	31
5	150	8 × 3/4"	48	43
6	150	8 × 3/4"	61	51

Nominal size [inch]	Flange class [lbs]	Bolts	Max. torque [Nm]	
			Polypropylene	Hardrubber
8	150	8 × 3/4"	-	69
10	150	12 × 7/8"	-	79
12	150	12 × 7/8"	-	104
14	150	12 × 1"	-	93
16	150	16 × 1"	-	91
18	150	16 × 1 1/8"	-	143
20	150	20 × 1 1/8"	-	127
24	150	20 × 1 1/4"	-	180

### Max. torque:

- Step 1: approx. 50% of max. torque
- Step 2: approx. 80% of max. torque
- Step 3: 100% of max. torque given in tables above

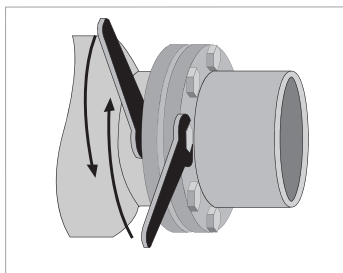

### Terminal assignment of IFC 070

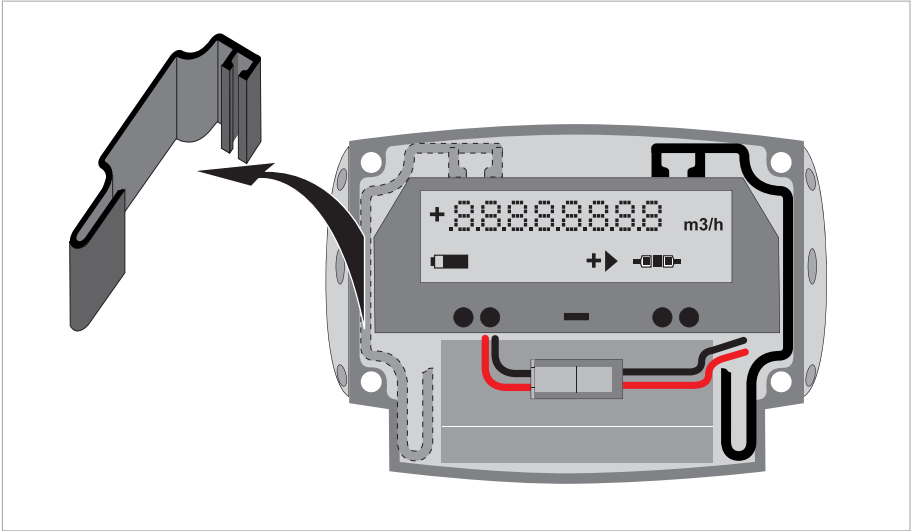

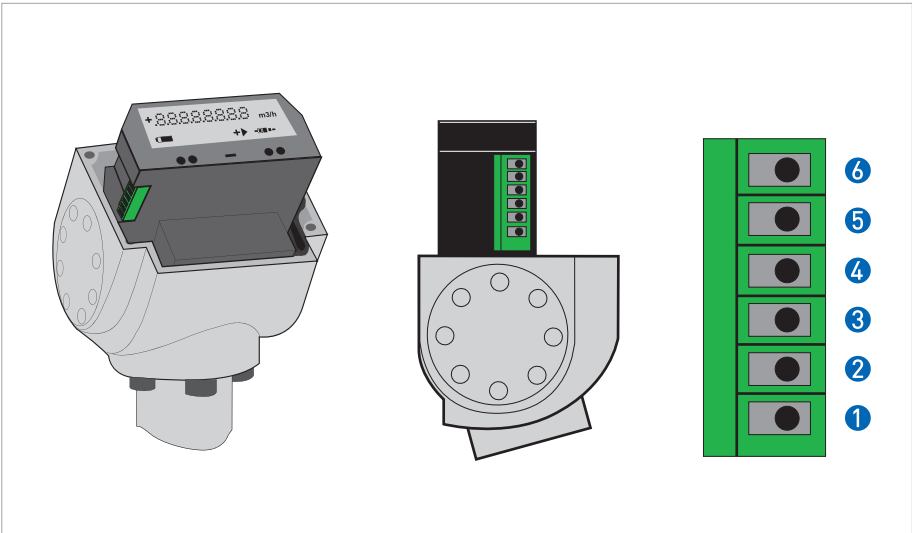

- ① Status output 1
- ② Status output 2
- ③ Not connected
- ④ Ground
- ⑤ Pulse output A
- ⑥ Pulse output B

## Electrical values

Pulse output passive:  $f \leq 500 \text{ Hz}$ ;  $I \leq 10 \text{ mA}$ ;  $U: 5 \dots 24 \text{ VDC}$  ( $P \leq 100 \text{ mW}$ )

Status output passive:  $I \leq 10 \text{ mA}$ ;  $U: 5 \dots 24 \text{ VDC}$  ( $P \leq 100 \text{ mW}$ )

## Signal and field current cable for remote version



### CAUTION!

Always use the supplied KROHNE signal cable.

## Cable connection for field version: flow sensor side

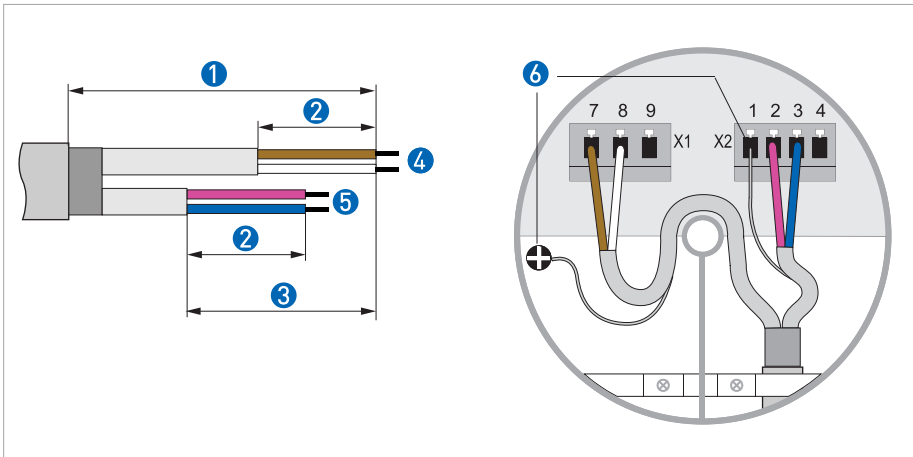

- ① cable length: 13 cm / 5"
- ② cable length: 5 cm / 2"
- ③ cable length: 8 cm / 3"
- ④ brown + white cable, used for field current
- ⑤ purple + blue cable, used for electrode signals
- ⑥ shield (terminal 1 of connector X2 + U-clamp)



- Prepare appropriate cable lengths (①...③).
- Connect the shield to the U-clamp, the brown cable to terminal 7 and the white to terminal 8.

- Connect the shield to terminal 1, the purple cable to terminal 2 and the blue to terminal 3.

### Cable connection for field version: converter side

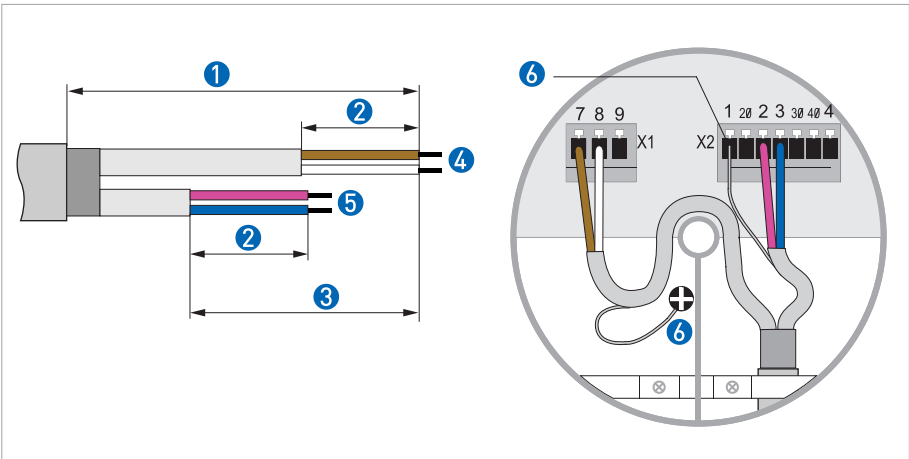

- ① cable length: 16 cm / 6.3"
- ② cable length: 5 cm / 2"
- ③ cable length: 10 cm / 4"
- ④ brown + white cable, used for field current
- ⑤ purple + blue cable, used for electrode signals
- ⑥ shield (terminal 1 of connector X2 + U-clamp)



- Prepare appropriate cable lengths (①...③).
- Connect the shield to the U-clamp, the brown cable to terminal 7 and the white to terminal 8.

- Connect the shield to terminal 1, the purple cable to terminal 2 and the blue to terminal 3.



## Connection of battery



### **CAUTION!**

*Please connect the battery before first use.*

*KROHNE delivers each IFC 070 converter with a disconnected battery.*

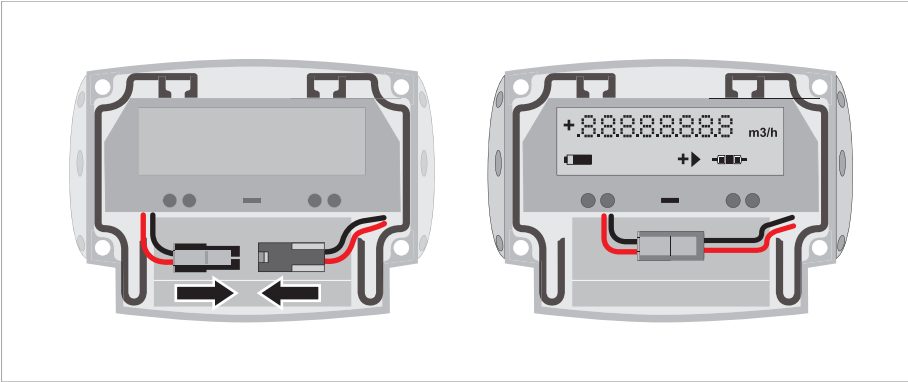

- remove the blue protection cap of the converter
- remove the 4 Allen bolts (4 mm)
- remove the cover
- fasten the battery connector to the internal connector in the IFC 070 converter
- check that the display lights up
- replace the cover

**WARNING!**

*Make sure that the battery cable is not jammed by the cover.*



- tighten the 4 Allen bolts
- replace the blue protection cap

## Display and operating elements

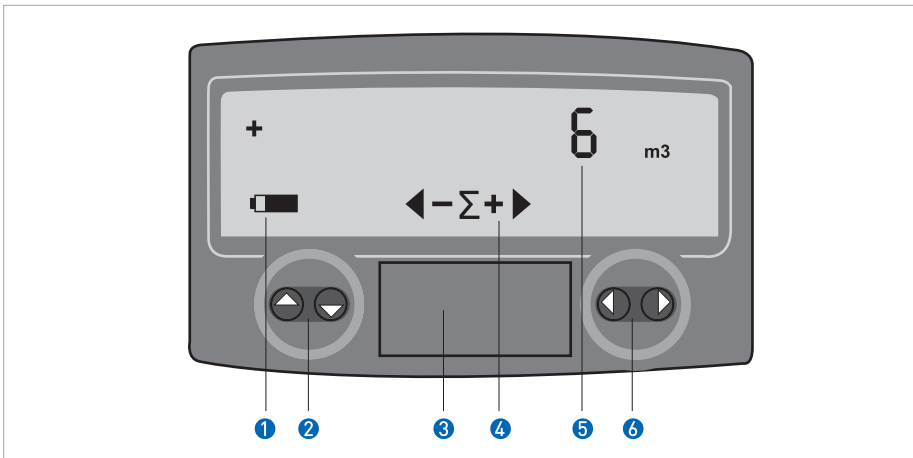

- 1 battery status
- 2 optical key  $\nabla$  to navigate through the menu and to scroll through the measuring pages
- 3 reset button (only accessible with removed cover)
- 4 flow direction
- 5 measured value and measuring unit
- 6 optical key  $\triangleright$  to navigate through the menu

## Programming



**NOTE!**

*KROHNE programs the signal converter according your wishes. It is ready to operate!*

*The handbook on the CD contains more details.*

- Display test: press ▷ button 2x 1s
- Software version: press ▷ button 1x 1s

## Contact

**KROHNE Altometer**

Kerkeplaat 12

3313 LC Dordrecht

Postbus 110

3300 AC Dordrecht, the Netherlands

[www.krohne.com](http://www.krohne.com)