



OPTIWAVE 7300 C Quick Start

24 GHz Non-contact Radar (FMCW) Level Meter

for distance, level, volume and mass measurement of liquids

1	Safety instructions	3
<hr/>		
2	Installation	4
<hr/>		
2.1	Intended use	4
2.2	Scope of delivery.....	4
2.3	Visual Check	6
2.4	Storage	7
2.5	Transport	8
2.6	Pre-installation requirements	8
2.7	How to prepare the tank before you install the device	9
2.7.1	Pressure and temperature ranges.....	9
2.7.2	Recommended mounting position.....	10
2.7.3	Theoretical data for hygienic applications	11
2.8	Installation recommendations for liquids.....	12
2.8.1	General requirements	12
2.8.2	Standpipes (stilling wells and bypass chambers)	13
2.9	How to install the device on the tank	14
2.9.1	How to install a device with a flange connection	14
2.9.2	How to install a device with a threaded connection	15
2.9.3	How to install a device with a hygienic connection	16
2.9.4	How to attach antenna extensions	19
2.9.5	How to turn or remove the signal converter	20
2.9.6	How to attach the weather protection to the device.....	21
2.9.7	How to open the weather protection	22
<hr/>		
3	Electrical connections	23
<hr/>		
3.1	Safety instructions.....	23
3.2	Electrical installation: outputs 1 and 2	23
3.2.1	Non-Ex devices	24
3.2.2	Devices for hazardous locations.....	24
3.3	Protection category	25
<hr/>		
4	Technical data	26
<hr/>		
4.1	Technical data.....	26

Warnings and symbols used



DANGER!

This information refers to the immediate danger when working with electricity.



DANGER!

These warnings must be observed without fail. Even partial disregard of this warning can lead to serious health problems and even death. There is also the risk of seriously damaging the device or parts of the operator's plant.



WARNING!

Disregarding this safety warning, even if only in part, poses the risk of serious health problems. There is also the risk of damaging the device or parts of the operator's plant.



CAUTION!

Disregarding these instructions can result in damage to the device or to parts of the operator's plant.



INFORMATION!

These instructions contain important information for the handling of the device.



HANDLING

- This symbol designates all instructions for actions to be carried out by the operator in the specified sequence.

➔ **RESULT**

This symbol refers to all important consequences of the previous actions.

Safety instructions for the operator



CAUTION!

Installation, assembly, start-up and maintenance may only be performed by appropriately trained personnel. The regional occupational health and safety directives must always be observed.



LEGAL NOTICE!

The responsibility as to the suitability and intended use of this device rests solely with the user. The supplier assumes no responsibility in the event of improper use by the customer. Improper installation and operation may lead to loss of warranty. In addition, the "Terms and Conditions of Sale" apply which form the basis of the purchase contract.



INFORMATION!

- Further information can be found on the supplied CD-ROM in the manual, on the data sheet, in special manuals, certificates and on the manufacturer's website.
- If you need to return the device to the manufacturer or supplier, please fill out the form contained on the CD-ROM and send it with the device. Unfortunately, the manufacturer cannot repair or inspect the device without the completed form.

2.1 Intended use

This radar level transmitter measures distance, level, mass, volume and reflectivity of liquids, pastes and slurries.

It can be installed on tanks, reactors and open channels.

2.2 Scope of delivery



INFORMATION!

Do a check of the packing list to make sure that you have all the elements given in the order.

Scope of delivery – horn antenna

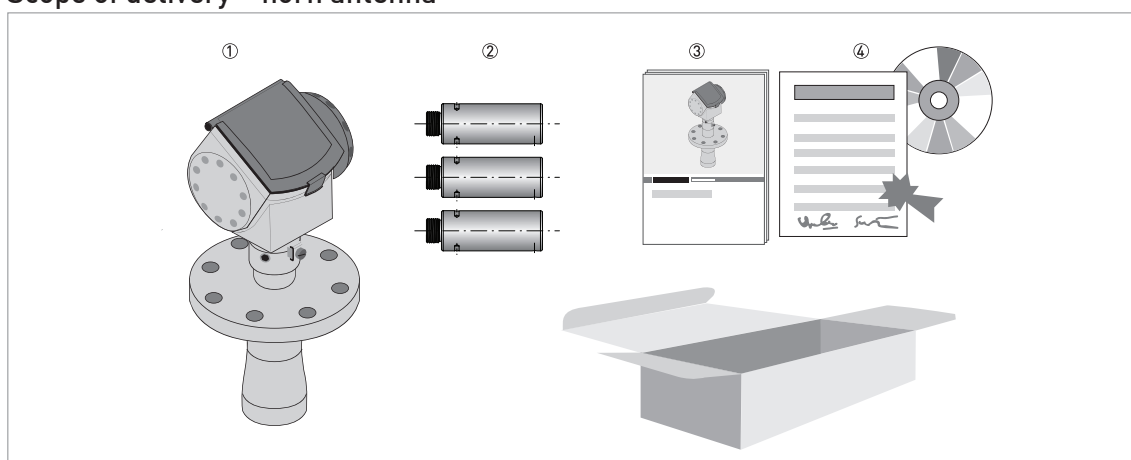

Figure 2-1: Scope of delivery – horn antenna

- ① Signal converter and antenna in compact version
- ② Antenna extensions (option)
- ③ Quick Start
- ④ DVD-ROM (including Handbook, Quick Start, Technical Datasheet and related software)

Scope of delivery – Drop antenna

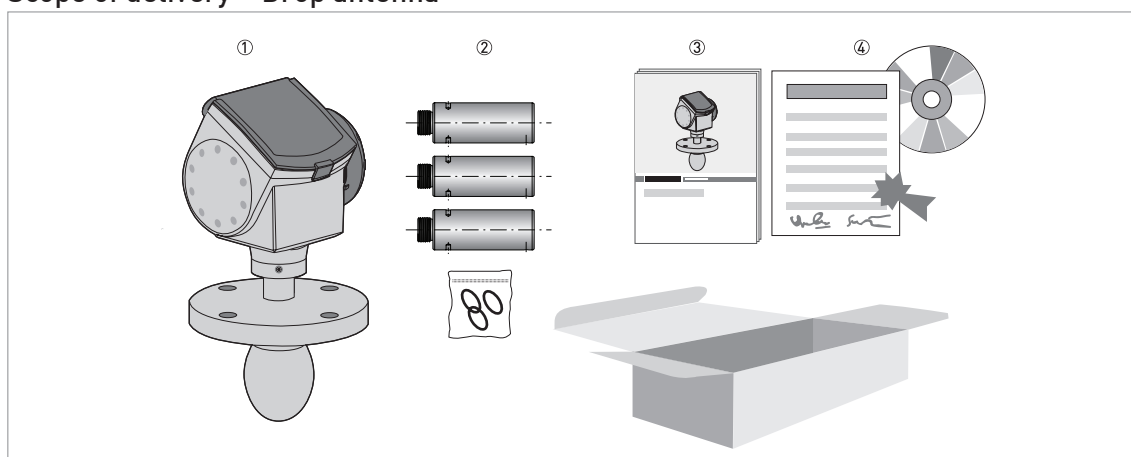
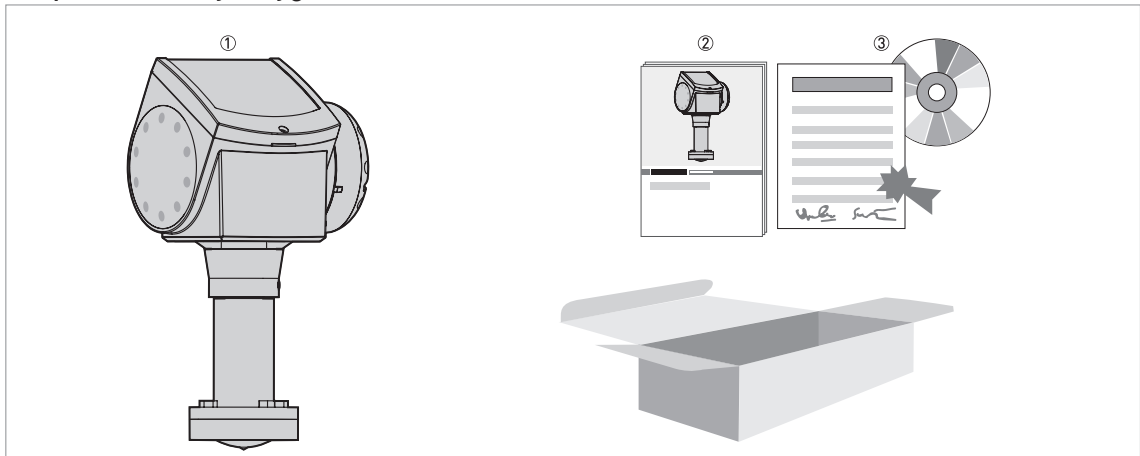

Figure 2-2: Scope of delivery – Drop antenna

- ① Signal converter and antenna in compact version
- ② Antenna extensions (option) and O-ring for each antenna extension
- ③ Quick Start
- ④ DVD-ROM (including Handbook, Quick Start, Technical Datasheet, and related software)

Scope of delivery – hygienic antenna**Figure 2-3: Scope of delivery – hygienic antenna**

- ① Signal converter and antenna in compact version
- ② Quick Start
- ③ DVD-ROM (including Handbook, Quick Start, Technical Datasheet, and related software)

***INFORMATION!***

No special tools or training required!

2.3 Visual Check



WARNING!
If the display screen glass is broken, do not touch.



INFORMATION!
Inspect the packaging carefully for damages or signs of rough handling. Report damage to the carrier and to the local office of the manufacturer.

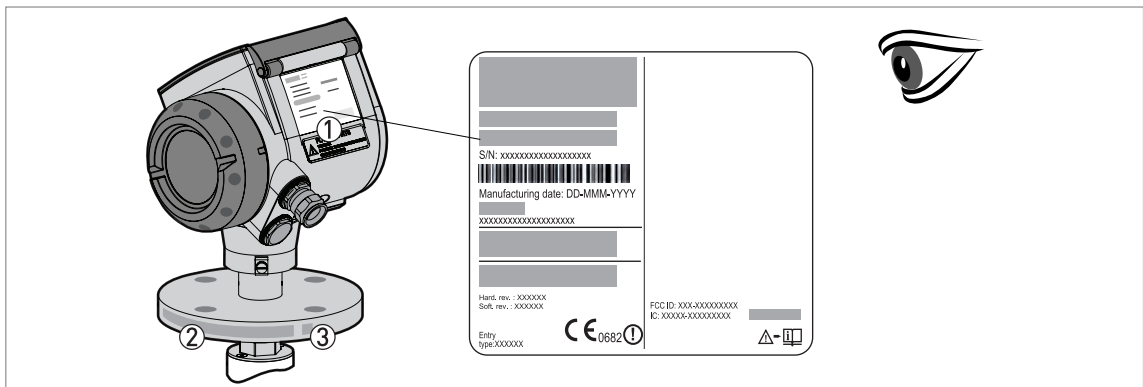

Figure 2-4: Visual check

- ① Device nameplate (for more data, refer to the handbook)
- ② Process connection data (size and pressure rating, material reference and heat number)
- ③ Gasket material data - refer to the illustration that follows

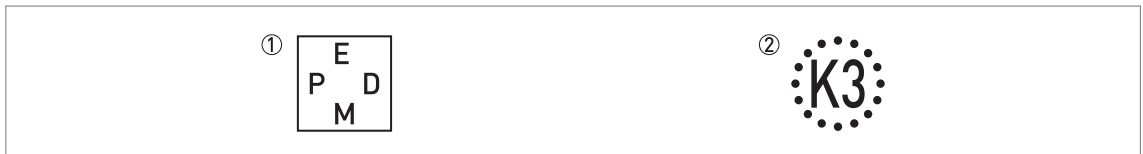

Figure 2-5: Symbols for the supplied gasket material (on the side of the process connection)

- ① EPDM
- ② Kalrez® 6375

If the device is supplied with an FKM/FPM gasket, there is no symbol on the side of the process connection.



INFORMATION!
Look at the device nameplate to ensure that the device is delivered according to your order. Check for the correct supply voltage printed on the nameplate.



INFORMATION!
Compare the material references on the side of the process connection with the order.

2.4 Storage

**WARNING!**

Do not keep the device in a vertical position. This will damage the antenna and the device will not measure correctly.

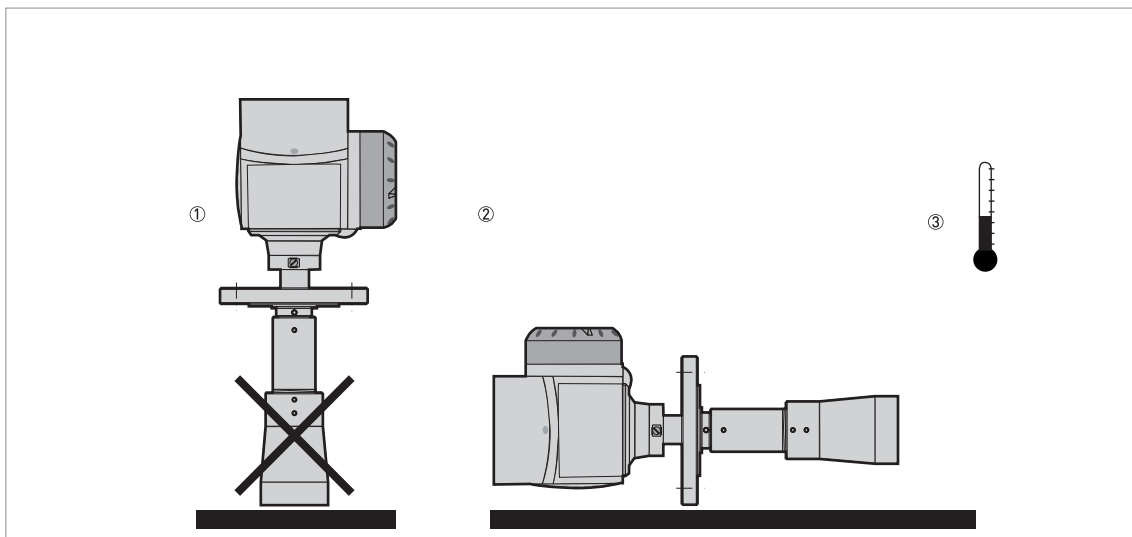

Figure 2-6: Storage conditions

- ① When you put the device into storage, do not keep it in a vertical position
- ② Put the device on its side. We recommend that you use the packaging in which it was delivered.
- ③ Storage temperature range: $-40\dots+85^{\circ}\text{C}$ / $-40\dots+185^{\circ}\text{F}$

- Store the device in a dry and dust-free location.
- Keep the converter out of the sunlight.
- Store the device in its original packing.

2.5 Transport

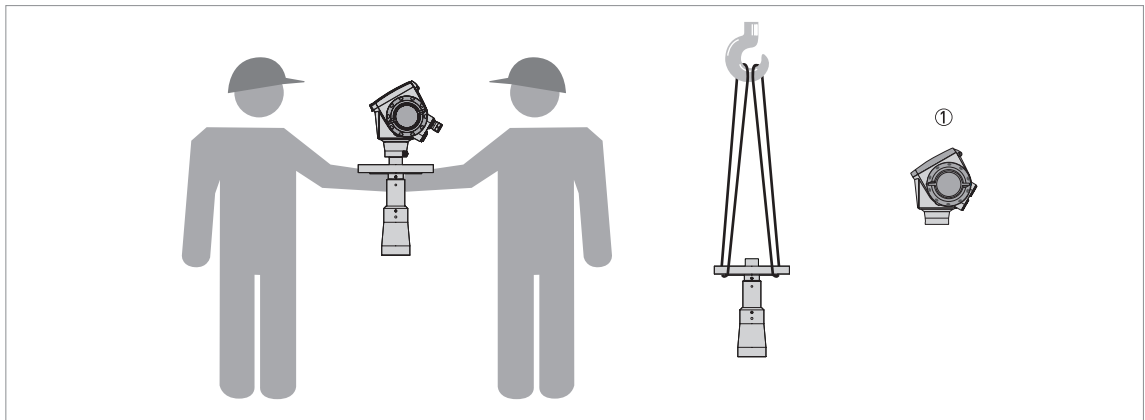

Figure 2-7: How to lift the device

① Remove the converter before you lift the device with a hoist.



WARNING!

Lift the device carefully to prevent damage to the antenna.

2.6 Pre-installation requirements



INFORMATION!

Obey the precautions that follow to make sure that the device is correctly installed.

- Make sure that there is sufficient space on all sides.
- Protect the signal converter from direct sunlight. If necessary, install the weather protection accessory.
- Do not subject the signal converter to heavy vibrations. The devices are tested for vibration and agree with EN 50178 and IEC 60068-2-6.

2.7 How to prepare the tank before you install the device



CAUTION!

To avoid measuring errors and device malfunction, obey these precautions.

2.7.1 Pressure and temperature ranges

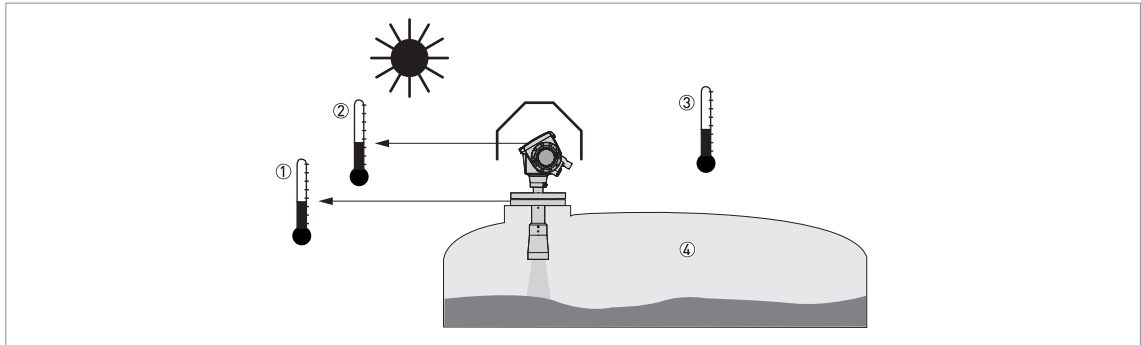

Figure 2-8: Pressure and temperature ranges

- ① Flange temperature
FKM/FPM gasket: -40...+200°C / -40...+390°F; Kalrez[®] 6375 gasket: -20...+200°C / -4...+390°F;
EPDM gasket: -50...+150°C / -58...+300°F
Depends on the antenna type. Refer to the table that follows.
Ex devices: see supplementary operating instructions
- ② Ambient temperature for operation of the display
-20...+60°C / -4...+140°F
If the ambient temperature is not between these limits, the display screen switches off automatically
- ③ Ambient temperature
Non-Ex devices: -40...+80°C / -40...+175°F
Ex devices: see supplementary operating instructions
- ④ Process pressure
Depends on the antenna type. Refer to the table that follows.



WARNING!

The process connection temperature range must agree with the temperature limits of the gasket material. The operating pressure range is subject to the process connection used and the flange temperature.

Antenna type	Maximum process connection temperature		Maximum operating pressure	
	[°C]	[°F]	barg	psig
PP Drop	+100	+210	16	232
PTFE Drop	+150	+300	40	580
Hygienic	+150	+300	10	145
Horn / Sheet metal horn	+150 (+200) ①	+300 (+390) ①	40 (100) ②	580 (1450) ②

① Standard max. process connection temperature: +150°C / +300°F. Optional max. process temperature: +200°C / +390°F.

② Standard operating pressure: 40 barg / 580 psig. Optional max. operating pressure: 100 barg / 1450 psig.

2.7.2 Recommended mounting position

**CAUTION!**

Follow these recommendations to make sure that the device measures correctly.

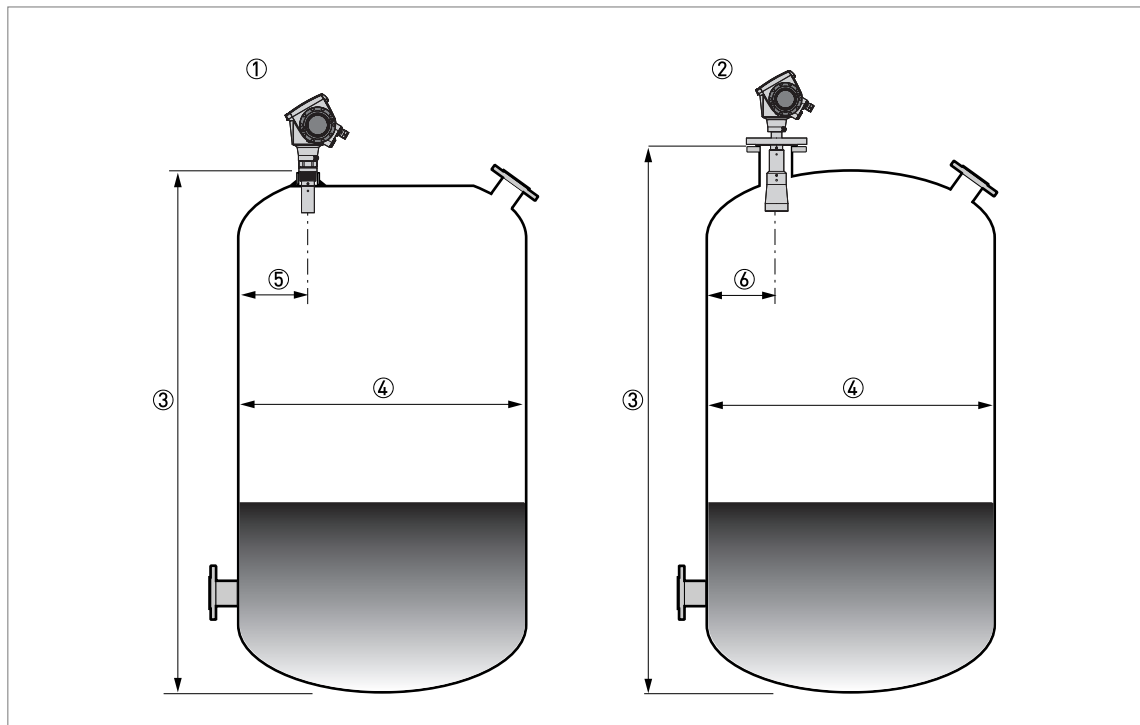

Figure 2-9: Recommended nozzle position for liquids, pastes and slurries

- ① Nozzles for DN40 or DN50 Horn antennas, or DN50 Hygienic antenna
- ② Nozzles for DN80, DN100, DN150 or DN200 Horn antennas and DN80 or DN150 Drop antennas
- ③ Tank height
- ④ Tank diameter
- ⑤ Minimum distance of nozzle from the tank wall : $1/7 \times$ tank height
Maximum distance of nozzle from the tank wall : $1/3 \times$ tank diameter
- ⑥ Minimum distance of nozzle from the tank wall : $1/10 \times$ tank height
Maximum distance of nozzle from the tank wall : $1/3 \times$ tank diameter

**INFORMATION!**

If possible, do not install a nozzle on the tank centerline.

**CAUTION!**

Do not put the device near to the product inlet. If the product that enters the tank touches the antenna, the device will measure incorrectly. If the product fills the tank directly below the antenna, the device will also measure incorrectly.

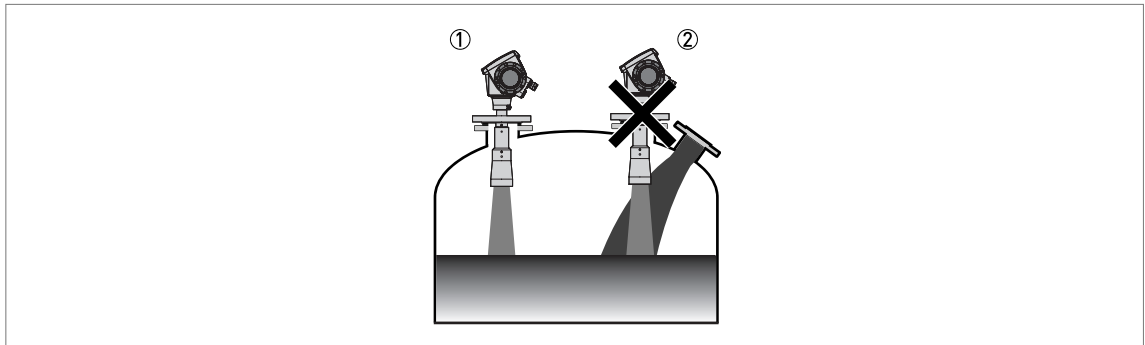

Figure 2-10: Product inlets

- ① The device is in the correct position.
- ② The device is too near to the product inlet.

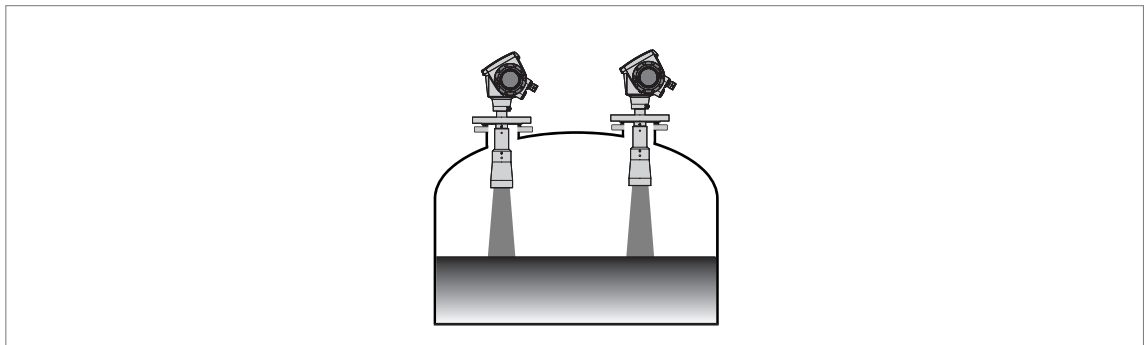

Figure 2-11: More than 1 FMCW radar level meter can be operated in a tank

More than 1 FMCW radar level meter can be operated in a tank.

2.7.3 Theoretical data for hygienic applications

To make the cleaning of the antenna easier, attach the device to a short socket.

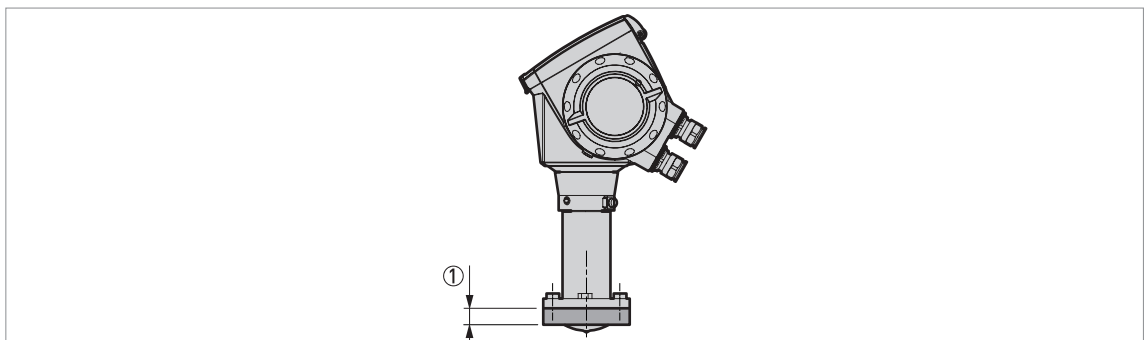

Figure 2-12: Requirements for hygienic applications

- ① Maximum height of process connection: 50 mm / 2"

2.8 Installation recommendations for liquids

2.8.1 General requirements



INFORMATION!

We recommend that you configure the device when the tank is empty.

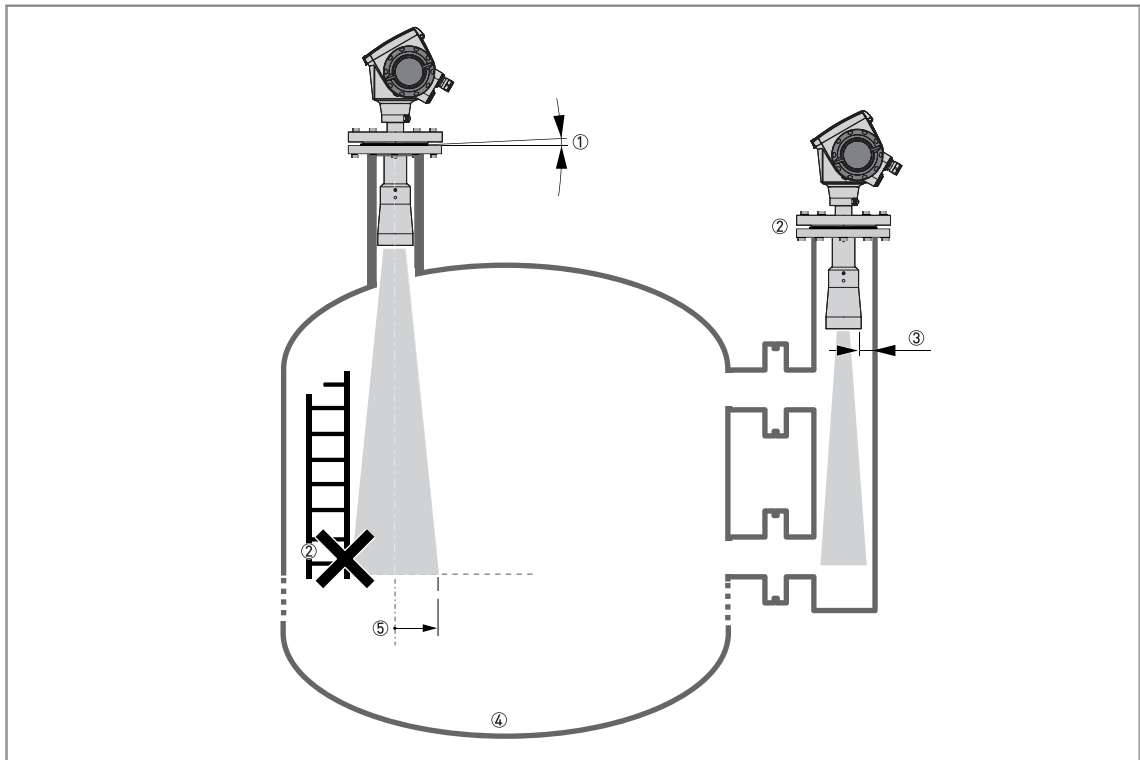

Figure 2-13: General Installation recommendations

- ① Do not tilt the device more than 2°
- ② We recommend that you do an empty spectrum recording if there are too many obstacles in the radar beam (refer to the handbook), or install a bypass chamber or stilling well.
- ③ 2.5 mm / 0.1" max. for high-dielectric constant liquids
- ④ Curved and conical tank bottoms. Refer to the handbook for fine adjustment of the device.
- ⑤ Beam radius (DN40 horn antenna): increments of 180 mm/m or 2.15"/ft (10°)
 Beam radius (DN50 horn antenna or DN50 Hygienic antenna): increments of 130 mm/m or 1.55"/ft (7.5°)
 Beam radius (DN80 horn antenna): increments of 90 mm/m or 1.1"/ft (5°)
 Beam radius (DN100 horn antenna or DN80 Drop antenna): increments of 70 mm/m or 0.83"/ft (4°)
 Beam radius (DN150 horn antenna): increments of 52.5 mm/m or 0.63"/ft (3°)
 Beam radius (DN150 Drop antenna or DN200 horn antenna): increments of 35 mm/m or 0.42"/ft (2°)

2.8.2 Standpipes (stilling wells and bypass chambers)

Use a standpipe if:

- There is highly conductive foam in the tank.
- The liquid is very turbulent or agitated.
- There are too many other objects in the tank.
- The device is measuring a liquid (petro-chemicals) in a tank with a floating roof.
- The device is installed in a horizontal cylindrical tank

For more data, refer to the Handbook.

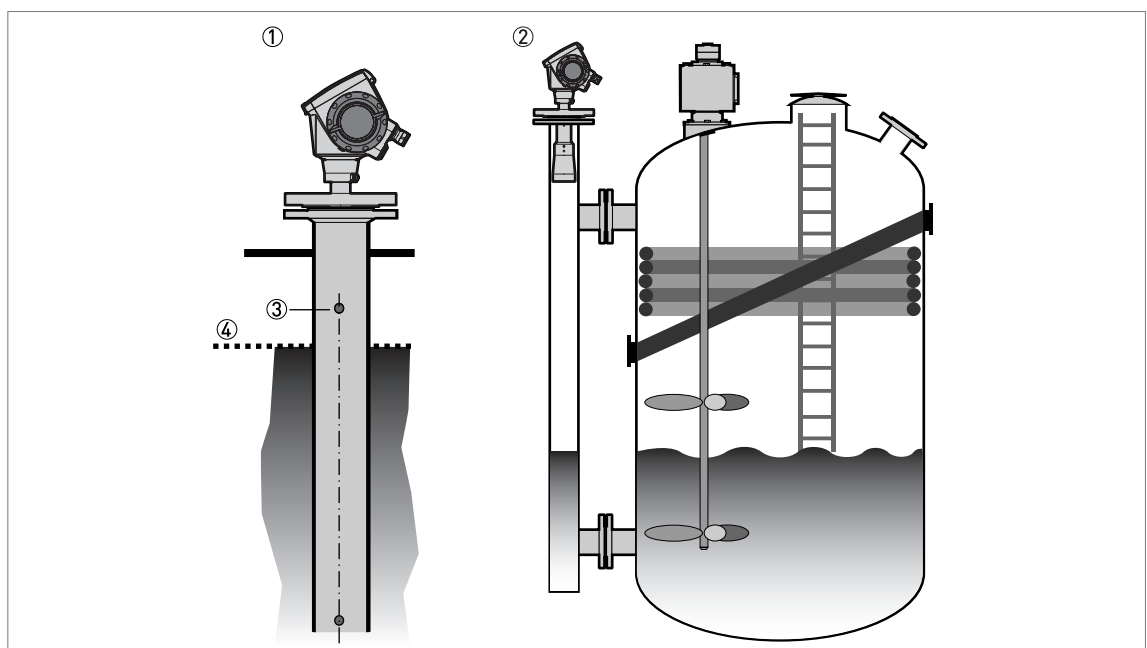

Figure 2-14: Installation recommendations for standpipes (stilling wells and bypass chambers)

- ① A stilling well solution
- ② A bypass chamber solution
- ③ Air circulation hole
- ④ Level of the liquid

2.9 How to install the device on the tank

2.9.1 How to install a device with a flange connection

Equipment needed:

- Device
- Gasket (not supplied)
- Nuts and bolts (not supplied)
- Wrench (not supplied)

Requirements for flange connections

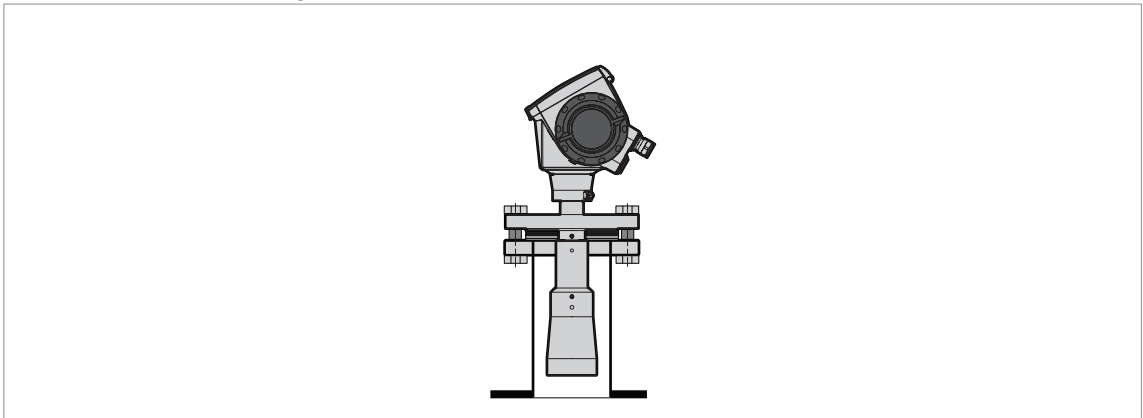

Figure 2-15: Flange connection



- Make sure the flange on the nozzle is level.
- Make sure that you use the applicable gasket for the flange dimensions and the process.
- Align the gasket correctly on the flange facing of the nozzle.
- Lower the antenna carefully into the tank.
- Tighten the flange bolts.
- ➡ Refer to local rules and regulations for the correct torque to apply to the bolts.

For more data, refer to the handbook.

2.9.2 How to install a device with a threaded connection

Equipment needed:

- Device
- Gasket for G 1½ connection (not supplied)
- 50 mm / 2" wrench (not supplied)

Requirements for threaded connections

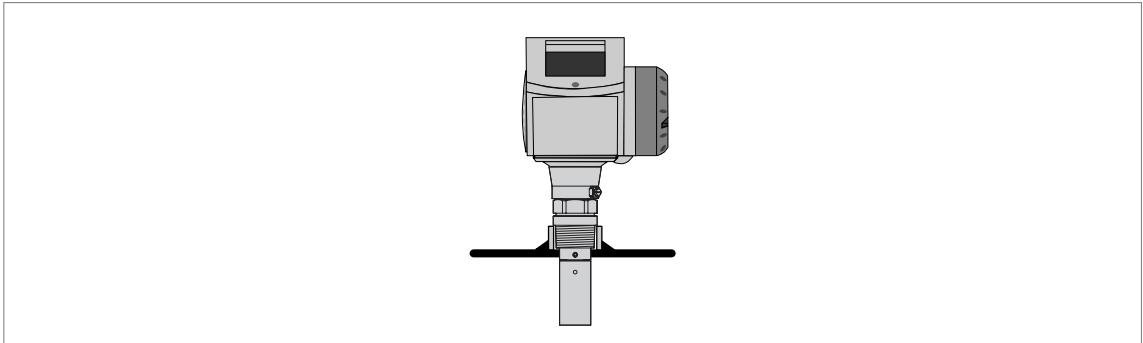

Figure 2-16: Threaded connection



- Make sure the tank connection is level.
- Make sure that you use the applicable gasket for the connection dimensions and the process.
- Align the gasket correctly.
- Lower the antenna carefully into the tank.
- Turn the threaded connection on the housing to attach the device to the process connection.
- Tighten the connection.
- ➔ Refer to local rules and regulations for the correct torque to apply to the connection.

For more data, refer to the handbook.

2.9.3 How to install a device with a hygienic connection

**INFORMATION!**

To make the cleaning of the antenna easier, attach the device to a short socket.

BioControl®**Equipment needed:**

- Device with BioControl® adaptor
- Flange bolts
- Wrench (not supplied)

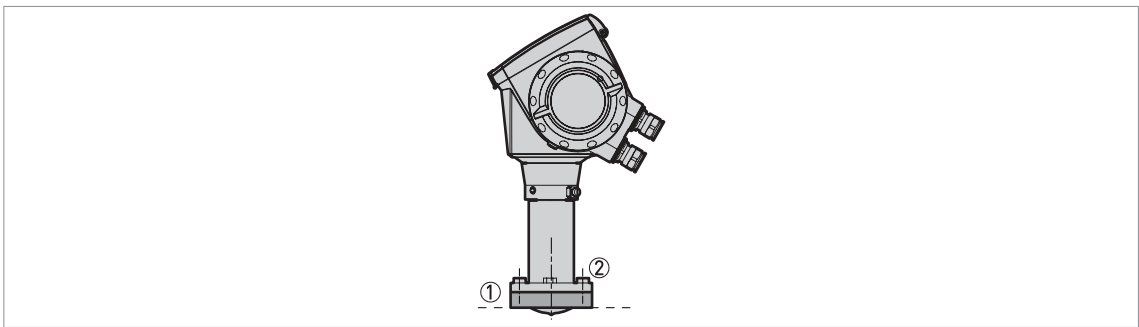

Figure 2-17: BioControl® connection

- ① BioControl® connection on the tank
- ② Flange bolts

**How to attach a device with a Biocontrol® connection**

- Make sure that the flange on the nozzle is level.
- Make sure that you use the applicable gasket for the process.
- Lower the antenna carefully into the tank.
- Tighten the flange bolts.
- ➔ Refer to local rules and regulations for the correct torque to apply to the bolts.

Tri-Clamp®

Equipment needed:

- Device with Tri-Clamp® adaptor
- Gasket (not supplied)
- Band clamp (not supplied)

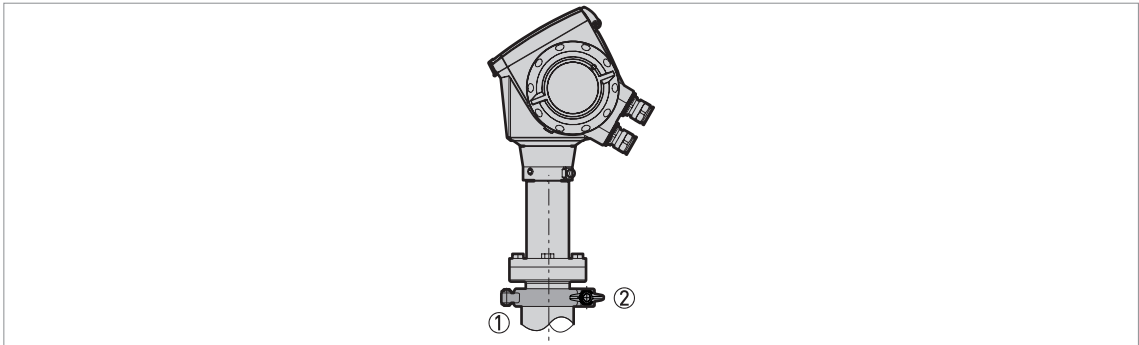

Figure 2-18: Tri-Clamp® connection

- ① Tank socket
- ② Band clamp



- Make sure that the tank connection is level.
- Make sure that you use the applicable gasket for the connection dimensions and the process.
- Align the gasket correctly.
- Lower the device with the Tri-Clamp® adaptor carefully on the tank process connection.
- Attach the band clamp to the process connection.
- Tighten the band clamp.

DIN 11851

Equipment needed:

- Device with a DIN 11851 adaptor
- Gasket (not supplied)
- DIN 11851 nut

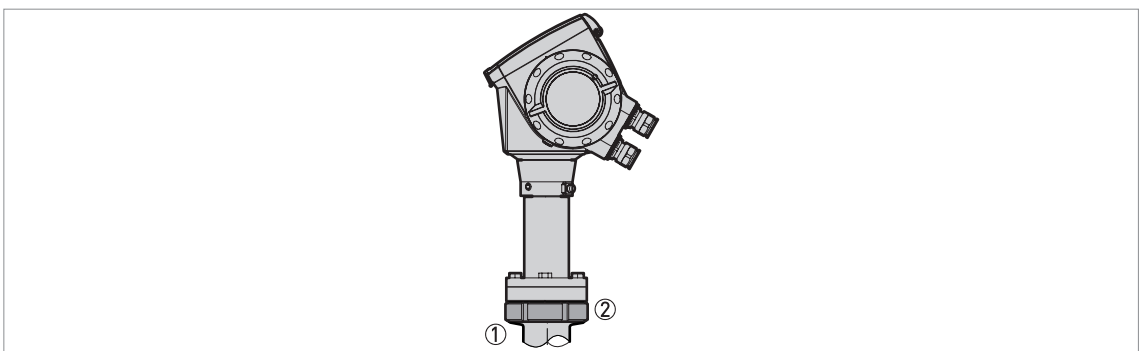

Figure 2-19: DIN 11851 connection

- ① Tank socket
- ② Nut for DIN 11851 connection



- Make sure that the tank connection is level.
- Make sure that you use the applicable gasket for the connection dimensions and the process.
- Align the gasket correctly.
- Lower the device with a DIN 11851 adaptor carefully on the tank process connection.
- Turn the nut on the device process connection to attach the device to the tank.
- Tighten the connection.
- ➡ Refer to local rules and regulations for the correct torque to apply to the connection.

SMS

Equipment needed:

- Device with a SMS adaptor
- Gasket (not supplied)
- SMS nut

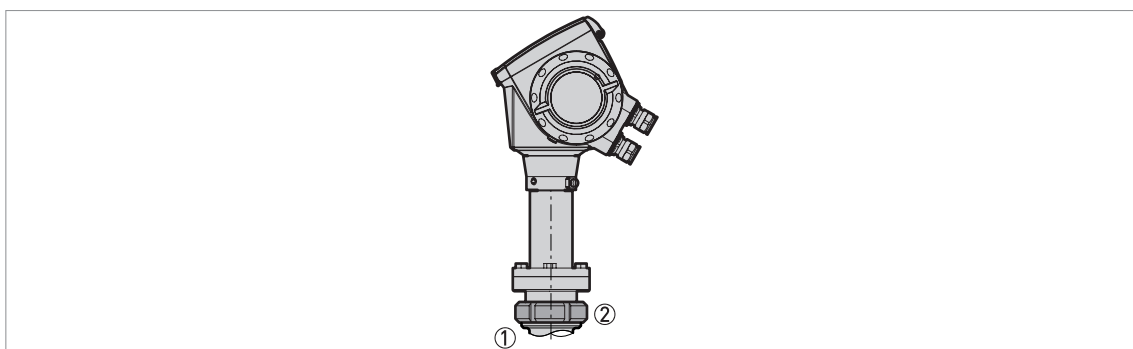

Figure 2-20: SMS connection

- ① Tank socket
- ② Nut for SMS connection



- Make sure the tank connection is level.
- Make sure that you use the applicable gasket for the connection dimensions and the process.
- Align the gasket correctly.
- Lower the device with a SMS adaptor on the tank process connection.
- Turn the nut on the device process connection to attach the device to the tank.
- Tighten the connection.
- ➡ Refer to local rules and regulations for the correct torque to apply to the connection.

VARIVENT®

Equipment needed:

- Device with a VARIVENT® adaptor
- Clamp (not supplied)

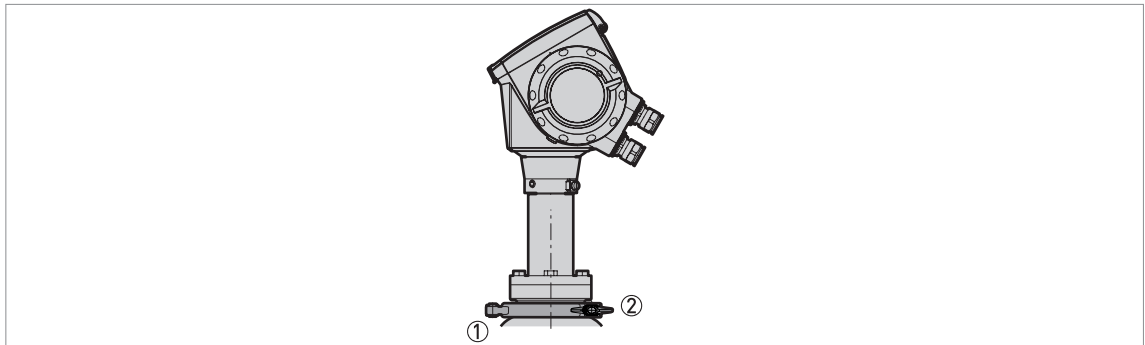

Figure 2-21: VARIVENT® connection

① Tank socket (VARIVENT® Access Unit – not supplied)



- Make sure the tank connection is level.
- Lower the device with a VARIVENT® adaptor on the tank process connection.
- Attach the clamp to the process connection.
- Tighten the clamp.

2.9.4 How to attach antenna extensions

Horn antenna - antenna extensions

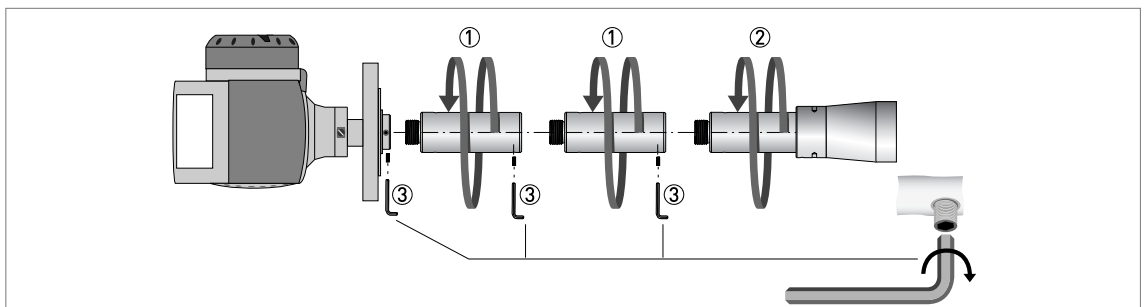

Figure 2-22: Horn antenna - how to attach antenna extensions

Equipment needed:

- 3 mm Allen wrench (not supplied)

For more data, refer to the handbook.

Drop antenna - antenna extensions

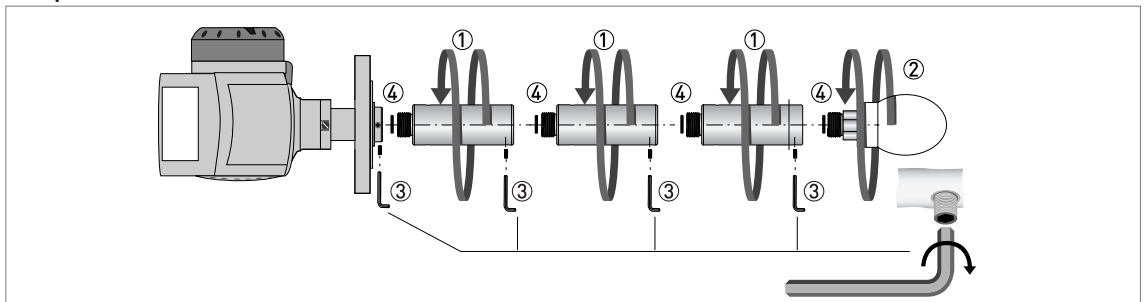

Figure 2-23: Drop antenna - how to attach antenna extensions

**INFORMATION!**

Drop antenna: Antenna extensions can only be attached below flanges without the PP/PTFE flange plate option

**CAUTION!**

Drop antenna: Make sure that there are not more than 5 antenna extensions attached to a device with a Drop antenna. If there are more than 5 antenna extensions, the device will not measure correctly.

Make sure that you put an O-ring ④ into the groove at the top of each antenna extension.

Equipment needed (not supplied):

- Torque wrench 200 Nm (for the H30 head of the Drop antenna sub-assembly)
- 3 mm Allen wrench

For more data, refer to the handbook.

2.9.5 How to turn or remove the signal converter

**INFORMATION!**

The converter turns 360°. The converter can be removed from the process connection assembly under process conditions.

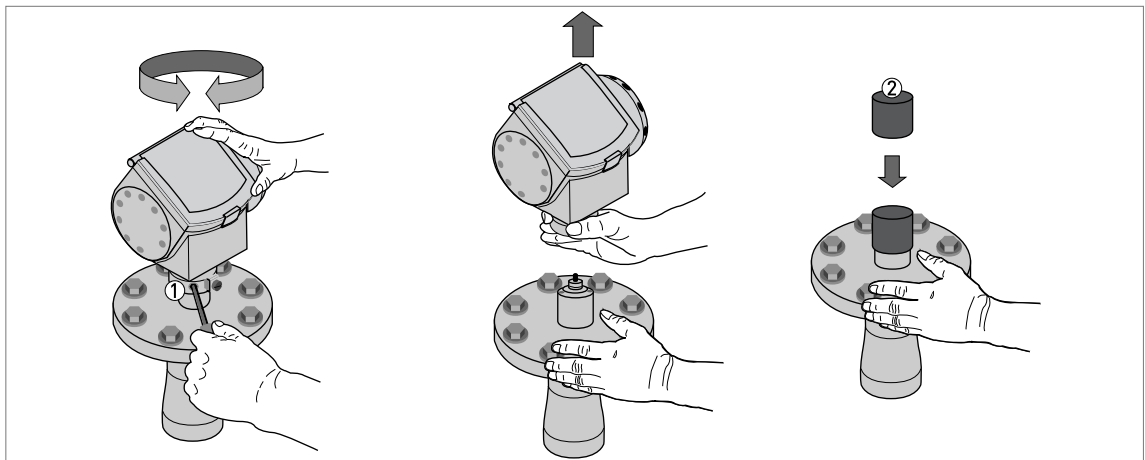

Figure 2-24: How to turn or remove the signal converter

- ① Tool: 5 mm Allen wrench (not supplied)
 ② Cover for the wave guide hole on top of the process connection assembly (not supplied)

**CAUTION!**

If you remove the converter, put a cover on the wave guide hole on top of the process connection assembly.

When the converter is attached to the process connection assembly, tighten the lock screw.

2.9.6 How to attach the weather protection to the device

Equipment needed:

- Device.
- Weather protection (option).
- 10 mm wrench (not supplied).

The overall dimensions of the weather protection are in "Dimensions and weight" in the handbook.

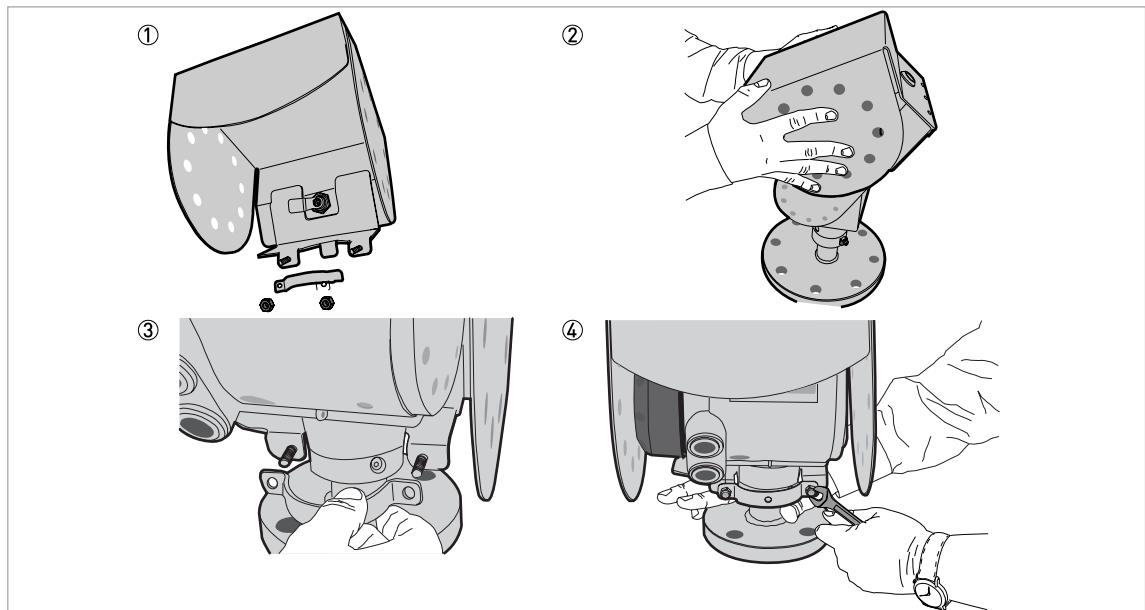

Figure 2-25: Installation of the weather protection



- Loosen the bracket nuts on the weather protection.
- Remove the bracket.
- Lower the weather protection onto the device.
- Turn the weather protection so that the keyhole points forward.
- Attach the bracket.
- Lift the weather protection to the top of the housing support pillar.
- Hold the weather protection in the correct position and tighten the bracket nuts.

2.9.7 How to open the weather protection

Equipment needed:

- Weather protection attached to the device.
- Large slotted tip screwdriver (not supplied).

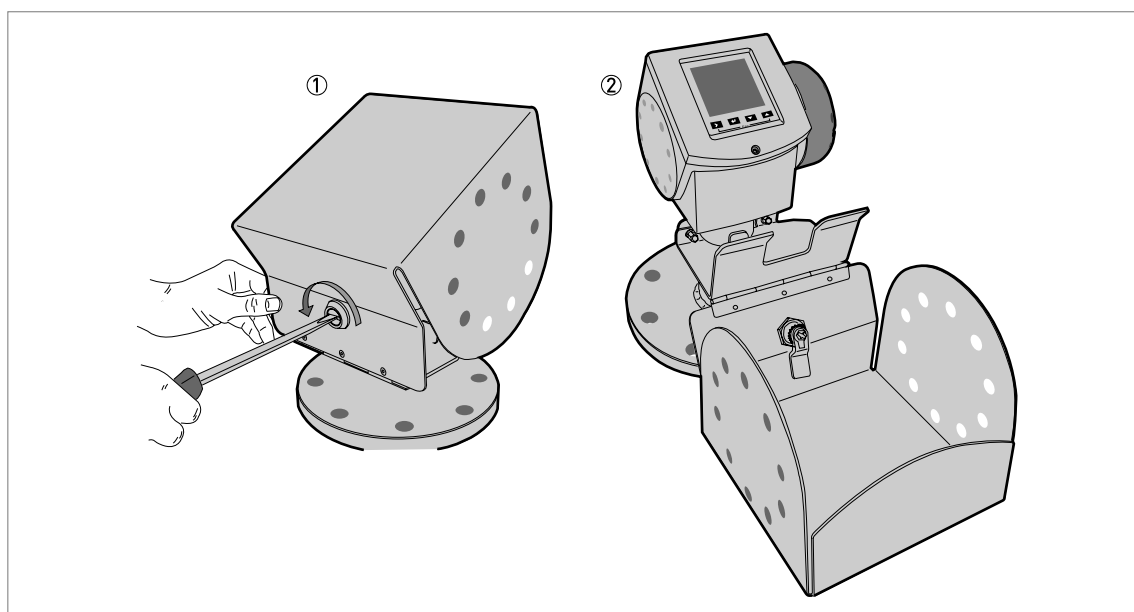

Figure 2-26: How to open the weather protection

- ① Weather protection in its closed position
- ② Weather protection in its open position. Minimum clearance in front of the device: 300 mm / 12".



- Put a large slotted tip screwdriver into the keyhole at the front of the weather protection. Turn the screwdriver counterclockwise.
- Pull the top of weather protection up and forward.
- ➡ This will open the weather protection.

3.1 Safety instructions



DANGER!

All work on the electrical connections may only be carried out with the power disconnected. Take note of the voltage data on the nameplate!



DANGER!

Observe the national regulations for electrical installations!



DANGER!

For devices used in hazardous areas, additional safety notes apply; please refer to the Ex documentation.



WARNING!

Observe without fail the local occupational health and safety regulations. Any work done on the electrical components of the measuring device may only be carried out by properly trained specialists.



INFORMATION!

Look at the device nameplate to ensure that the device is delivered according to your order. Check for the correct supply voltage printed on the nameplate.

3.2 Electrical installation: outputs 1 and 2

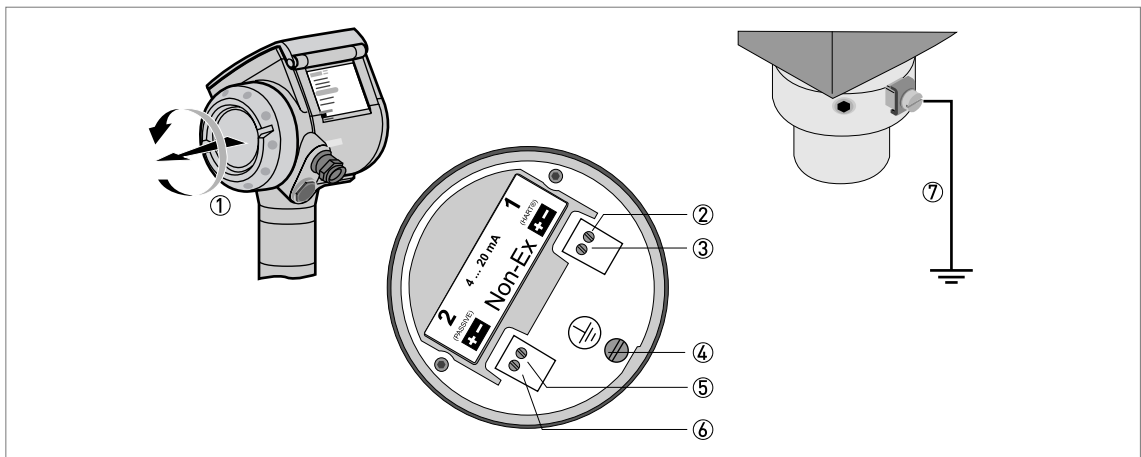

Figure 3-1: Electrical installation

- ① Terminal compartment cover
- ② Output 1: current output -
- ③ Output 1: current output +
- ④ Grounding terminal in the housing
- ⑤ Output 2: current output - (option)
- ⑥ Output 2: current output + (option)
- ⑦ Grounding terminal between the process connection and the converter

Output 1 energizes the device and is used for HART[®] communication. If the device has the second current output option, use a separate power supply to energize output 2.

**Procedure:**

- Remove the housing terminal compartment cover ①.
- Connect the wires to the device. Obey the national electrical codes.
- Make sure that the polarity of the wires is correct.
- Attach the ground to ④ or ⑦. Both terminals are technically equivalent.

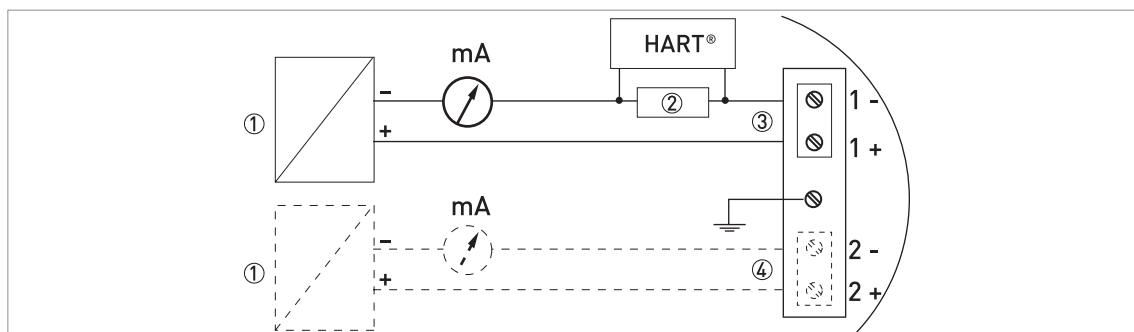
3.2.1 Non-Ex devices**Figure 3-2: Electrical connections for non-Ex devices (standard software)**

- ① Power supply
- ② Resistor for HART® communication
- ③ Output 1: 14...30 VDC for an output of 22 mA at the terminal
- ④ Output 2: 10...30 VDC for an output of 22 mA at the terminal

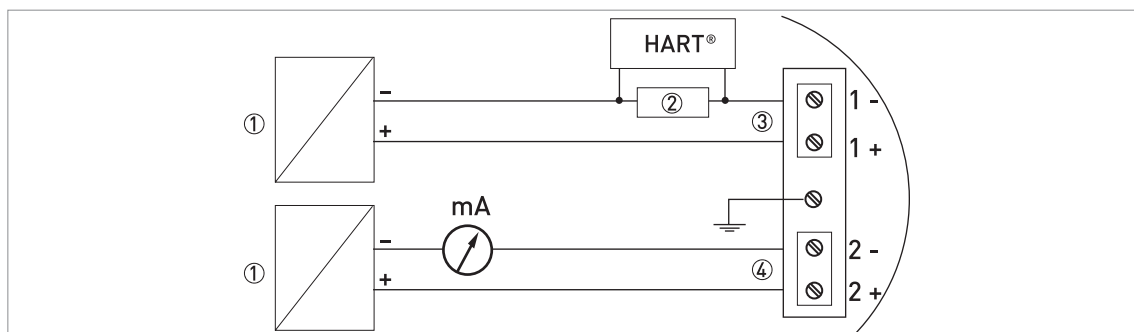
**Figure 3-3: Electrical connections for non-Ex devices (fast motion software option)**

- ① Power supply
- ② Resistor for HART® communication
- ③ Output 1: 14...30 VDC for a constant output of 16 mA at the terminal
- ④ Output 2: 10...30 VDC for an output of 22 mA at the terminal

3.2.2 Devices for hazardous locations**DANGER!**

For electrical data for device operation in hazardous locations, refer to the related certificates of compliance and supplementary instructions (ATEX, IECEx, FM, CSA etc.). You can find this documentation on the DVD-ROM delivered with the device or it can be downloaded free of charge from the website (Download Center).

3.3 Protection category

**INFORMATION!**

The device fulfils all requirements per protection category IP66 / IP67. It also fulfils all requirements per NEMA type 4X (housing) and type 6P (antenna).

**DANGER!**

Make sure that the cable gland is watertight.

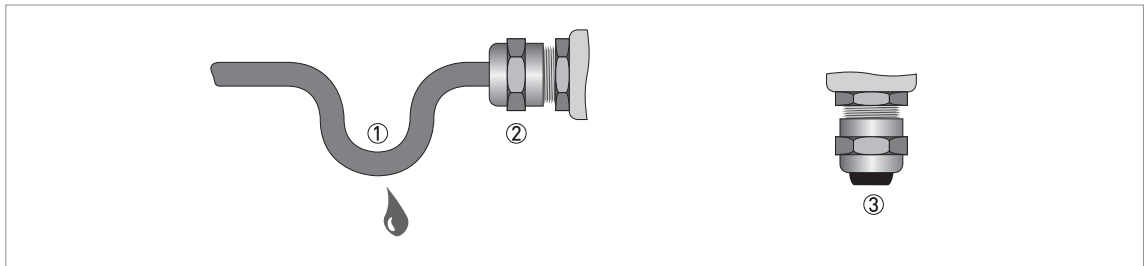

Figure 3-4: How to make the installation agree with protection category IP 67



- Make sure that the gaskets are not damaged.
- Make sure that the electrical cables are not damaged.
- Make sure that the electrical cables agree with the national electrical code.
- The cables are in a loop in front of the device ① so water does not go into the housing.
- Tighten the cable feedthroughs ②.
- Close unused cable feedthroughs with dummy plugs ③.

4.1 Technical data



INFORMATION!

- The following data is provided for general applications. If you require data that is more relevant to your specific application, please contact us or your local sales office.
- Additional information (certificates, special tools, software,...) and complete product documentation can be downloaded free of charge from the website (Download Center).

Measuring system

Measuring principle	2-wire loop-powered level transmitter; K-band (24...26 GHz) FMCW radar
Application range	Level measurement of liquids, pastes and slurries
Primary measured value	Δf (change in frequency) between the emitted and received signal
Secondary measured value	Distance, level, volume, mass and reflectivity

Design

Construction	The measurement system consists of a measuring sensor (antenna) and a signal converter which is only available in a compact version
Options	Integrated LCD display with sun cover (-20...+60°C / -4...+140°F); if the ambient temperature is not in these limits, the display switches off
	2nd current output
	Fast motion software (5 measurements per second)
	PTFE/PP flange plate protection (for Drop antennas without antenna extensions only)
	Distance piece (for process connection temperature: +150...+200°C / +300...+390°F) ①
Antenna purging system (supplied with a ¼ NPTF connection)	
Accessories	Weather protection
	Antenna extensions of 105 mm / 4.1" length (Max. length for Drop antenna versions: 525 mm / 20.7"; not available for the Hygienic antenna)
	Discs (low-pressure flanges) with bolt hole dimensions and positions that agree with DN80...200 in PN2.5...40 or 3"...8" in 150 lb for devices with the G 1½ threaded connection. Max. pressure: 1 barg / 14.5 psig at +20°C / +68°F.
Max. measuring range	80 m / 260 ft
	Depends on the antenna option, dielectric constant of the product and installation type. Refer also to "Antenna selection".
Min. tank height	0.2 m / 8" (1 m / 40" for hygienic antenna)
Max. change in level	Standard software: 1...10 m/minute / 3.3...32.8 ft/minute
	Fast motion software: The device uses strongest signal in the measuring range to calculate the distance for each measurement cycle. The menu item for tracing velocity is available, but the function is disabled and changes have no effect on the performance of the device.
Min. dead zone	Antenna extension length + antenna length + 0.1 m / 4" (200 mm / 8" for the hygienic antenna)

Beam angle of antenna	Horn DN40 / 1.5": 20°
	Horn DN50 / 2": 15°
	Horn / Sheet metal horn DN80 / 3": 10°
	Horn / Sheet metal horn DN100 / 4": 8°
	Sheet metal horn DN150 / 6": 6°
	Sheet metal horn DN200 / 8": 4°
	Drop DN80 / 3": 8°
	Drop DN150 / 6": 4°
Hygienic DN50 / 2": 15°	
Display and user interface	
Display	LCD display
	9 lines, 160 × 160 pixels in 8-step grayscale with 4-button keypad
Interface languages	English, German, French, Italian, Spanish, Portuguese, Japanese, Simplified Chinese and Russian

Measuring accuracy

Resolution	1 mm / 0.04"
Repeatability	±1 mm / ±0.04"
Accuracy	±3 mm / ±0.12", when distance < 10 m / 33 ft; ±0.03% of measured distance, when distance > 10 m / 33 ft
Reference conditions acc. to EN 60770	
Temperature	+20°C ±5°C / +70°F ±10°F
Pressure	1013 mbara ±20 mbar / 14.69 psia ±0.29 psi
Relative air humidity	60% ±15%
Target	Metal plate in an anechoic chamber

Operating conditions

Temperature	
Ambient temperature	-40...+80°C / -40...+175°F (according to the temperature limits of the gasket material. Refer to "Materials" in this table.) Ex: see supplementary operating instructions or approval certificates
Storage temperature	-40...+85°C / -40...+185°F
Process connection temperature	Horn / Sheet metal horn antenna: Standard: -50...+150°C / -58...+300°F Option: -50...+200°C / -58...+390°F (the process connection temperature must agree with the temperature limits of the gasket material. Refer to "Materials" in this table.) Ex: see supplementary operating instructions or approval certificates
	Drop antenna (PTFE): -50...+150°C / -58...+300°F (the process connection temperature must agree with the temperature limits of the gasket material. Refer to "Materials" in this table.) Ex: see supplementary operating instructions or approval certificates
	Drop antenna (PP): -40...+100°C / -40...+210°F (the process connection temperature must agree with the temperature limits of the gasket material. Refer to "Materials" in this table.) Ex: see supplementary operating instructions or approval certificates
	Hygienic antenna (PEEK): -20...+150°C / -4...+300°F (the process connection temperature must agree with the temperature limits of the gasket material. Refer to "Materials" in this table.) Ex: see supplementary operating instructions or approval certificates

Pressure	
Operating pressure	Drop antenna (PP): -1...16 barg / -14.5...232 psig; subject to process connection used and flange temperature
	Drop antenna (PTFE): -1...40 barg / -14.5...580 psig; subject to process connection used and flange temperature
	Hygienic antenna (PEEK): -1...10 barg / -14.5...145 psig; subject to process connection used and flange temperature
	Horn / Sheet metal horn antenna: Standard: -1...40 barg / -14.5...580 psig; Option: -1...100 barg / -14.5...1450 psig; subject to process connection used and flange temperature
Other conditions	
Dielectric constant $\{\epsilon_r\}$	≥ 1.5
Vibration resistance	IEC 60068-2-6 and EN 50178 (10...57 Hz: 0.075 mm / 57...150 Hz: 1g)
Ingress protection	IP66/67 equivalent to NEMA type 4X (housing) and type 6P (antenna)

Installation conditions

Process connection size	The nominal diameter (DN) should be equal to or larger than the antenna diameter. If the nominal diameter (DN) is smaller than the antenna, either: – provide the means to adapt the device to a larger process connection on the tank (for example, a plate with a slot), or – use the same process connection, but remove the antenna from the device before installation and fit it from inside the tank.
Process connection position	Make sure that there are not any obstructions directly below the process connection for the device.
Dimensions and weights	Refer to "Technical data: Dimensions and weights" in the Handbook.

Materials

Housing	Standard: Polyester-coated aluminium
	Option: Stainless steel (1.4404 / 316L) ②
Wetted parts, including antenna	Standard for Horn / Sheet metal horn antenna: Stainless steel (1.4404 / 316L)
	Option for Horn antenna: Hastelloy® C-22® (2.4602) ③
	Standard for Drop antenna: PTFE; PP
	Option for Drop antenna: PP or PTFE flange plate protection
	Hygienic antenna: PEEK – this material agrees with FDA regulations
Process connection	Standard for Horn, Sheet metal horn and Drop antennas: Stainless steel (1.4404 / 316L) – a PP or PTFE flange plate protection option is also available for the Drop antenna Standard for Hygienic antenna: Stainless steel (1.4404 / 316L)
	Option: Hastelloy® C-22® (2.4602) – for Horn antennas only
Gaskets (and O-rings for the sealed antenna extension option)	Hygienic antenna: EPDM (-20°C...+150°C / -4...+300°F); FKM/FPM (-20...+150°C / -4...+300°F)
	PTFE Drop antenna: FKM/FPM (-40...+150°C / -40...+300°F); Kalrez® 6375 (-20...+150°C / -4...+300°F); EPDM (-50°C...+150°C / -58...+300°F) ④
	PP Drop antenna: FKM/FPM (-40...+100°C / -40...+210°F); Kalrez® 6375 (-20...+100°C / -4...+210°F); EPDM (-40°C...+100°C / -40...+210°F) ④
	Horn / Sheet metal horn antenna: FKM/FPM (-40...+200°C / -40...+390°F); Kalrez® 6375 (-20...+200°C / -4...+390°F); EPDM (-50°C...+150°C / -58...+300°F) ④

Feedthrough	Standard: PEI (-50...+200°C / -58...+390°F – max. range. The feedthrough temperature limits must agree with the temperature limits of the gasket material and antenna type. If the distance piece option is not attached, the maximum temperature is +150°C / +300°F.)
	Option: Metaglas® (-30...+200°C / -22...+390°F – max. range. The feedthrough temperature limits must agree with the temperature limits of the gasket material and antenna type. If the distance piece option is not attached, the maximum temperature is +150°C / +300°F.) ⑤
Weather protection (Option)	Stainless steel (1.4301 / 304)

Process connections

Thread	G 1½ (ISO 228); 1½ NPT (ASME B1.20.1)
Flange version	
EN 1092-1	DN40...80 in PN40 (Type B1), DN100...200 in PN16 or PN40 (Type B1), DN40...150 in PN63 or PN100 (Type B1); others on request Optional flange facing: Types C, D, E and F
ASME B16.5	1½"...8" in 150 lb RF, 1½"...6" in 300 lb RF, 1½"...4" in 600 lb or 900 lb RF; 1½"...2" in 1500 lb RJ; others on request Optional flange facing: RJ (Ring Joint)
JIS B2220	40...100A in 10K; others on request
Hygienic	BioControl® DN50; Tri-Clamp® 2"; DIN 11851 DN50; SMS 51; VARIVENT® DN50; others on request ⑥
Other	Others on request

Electrical connections

Power supply	Terminals output 1 – Non-Ex / Ex i: 14...30 VDC; min./max. value for an output of 22 mA at the terminal
	Terminals output 1 – Ex d: 20...36 VDC; min./max. value for an output of 22 mA at the terminal
	Terminals output 2 – Non-Ex / Ex i / Ex d 10...30 VDC; min./max. value for an output of 22 mA at the terminal (additional power supply needed – output only)
Cable entry	M20×1.5; ½ NPT
	G ½ (not for FM- and CSA-approved devices. Not for stainless steel housings.)
	Stainless steel housings: M20×1.5
Cable gland	Standard: none
	Options: M20×1.5; others are available on request
Cable entry capacity (terminal)	0.5...1.5 mm²

Input and output

Current output (standard software)	
Output signal (Output 1)	4...20 mA HART® or 3.8...20.5 mA acc. to NAMUR NE 43 ⑦
Output signal (Output 2 – optional)	4...20 mA (no HART® signal) or 3.8...20.5 mA acc. to NAMUR NE 43
Current output (fast motion software option)	
Output signal (Output 1)	16 mA HART® ⑦
Output signal (Output 2)	4...20 mA (no HART® signal) or 3.8...20.5 mA acc. to NAMUR NE 43

Resolution	±3 µA
Temperature drift	Typically 50 ppm/K
Error signal	High: 22 mA; Low: 3.6 mA acc. to NAMUR NE 43

Approvals and certification

CE	This device fulfils the statutory requirements of the EC directives. The manufacturer certifies successful testing of the product by applying the CE mark.
Explosion protection	
ATEX KEMA 04ATEX1218 X ⑧	II 1 G, 1/2 G, 2 G Ex ia IIC T6...T3;
	II 1 D, 1/2 D, 2 D Ex iaD 20 or Ex iaD 20/21 IP6X T70°C...T95°C;
	II 1/2 G, 2 G Ex d[ia] IIC T6...T3;
	II 1/2 D, 2 D Ex tD[iaD] A21/20 IP6X T70°C...T95°C;
	II 3 G Ex nA II T6...T3 X
IECEX IECEX KEM 06.0025 X ⑧	Ga Ex ia IIC T6...T3; Ex iaD 20 IP6X T70°C...T 95°C;
	Ga/Gb Ex d[ia] IIC T6...T3; Ex tD[iaD] A21/20 IP6X T70°C...T 95°C
FM – Dual Seal-approved ⑨	NEC 500
	XP-IS / Cl. I / Div. 1 / Gr. ABCD / T6-T1;
	DIP / Cl. II, III / Div. 1 / Gr. EFG / T6-T1;
	IS / Cl. I, II, III / Div. 1 / Gr. ABCDEFG / T6-T1;
	NI / Cl. I / Div. 2 / Gr. ABCD / T6-T1
	NEC 505
	Cl. I / Zone 0 / AEx d[ia] / IIC / T6-T1;
	Cl. I / Zone 0 / AEx ia / IIC / T6-T1;
	Cl. I / Zone 2 / AEx nA[ia] / IIC / T6-T1
	Hazardous (Classified) Locations, indoor/outdoor Type 4X and 6P, IP66, Dual Seal
CSA – Dual Seal-approved ⑨	CEC Section 18 (Zone ratings)
	Cl. I, Zone 1, Ex d, IIC (Antenna: Zone 0) T6;
	Cl. I, Zone 0, Ex ia, IIC T6;
	Cl. I, Zone 2, Ex nA, IIC T6
	CEC Section 18 and Annex J (Division ratings)
	XP-IS, Cl. I, Div. 2, Gr. ABCD; Cl. II, Div. 2, Gr. FG; Cl. III, Div. 2 T6;
	IS, Cl. I, Div. 1, Gr. ABCD; Cl. II, Gr. FG; Cl. III T6
NEPSI GYJ111193/94 ⑨	Ex dia IIC T3~T6 DIP A21/A20 T _A T70°C~T95°C IP6X;
	Ex ia IIC T3~T6 DIP A21/A20 T _A T70°C~T95°C IP6X
DNV / INMETRO DNV 12.0043 X ⑨	Ex ia IIC T6...T3 Ga; Ex ia IIIC T70°C...T95°C Da IP6X;
	Ex d [ia Ga] IIC T6...T3 Ga/Gb; Ex tb [ia Da] IIIC T70°C...T95°C Db IP6X
KGS 11-GA4B0-0324X 11-GA4B0-0329X ⑨	Ex ia IIC T6~T3; Ex iaD 20 IP6X T70°C~T95°C;
	Ex d[ia] IIC T6~T3; Ex tD[iaD] A21/20 IP6X T70°C~T95°C

Other standards and approvals	
EMC	Electromagnetic Compatibility Directive 2004/108/EC in conjunction with EN 61326-1 (2013)
R & TTE	Radio Equipment and Telecommunications Terminal Equipment Directive 1999/5/EC in conjunction with ETSI EN 302 372-2 (2011) and ETSI EN 302 729-2 (2011)
FCC Rules	Part 15
Industry Canada	RSS-210
LVD	Low-Voltage Directive 2006/95/EC in conjunction with EN 61010-1 (2001)
NAMUR	NAMUR NE 21 Electromagnetic Compatibility (EMC) of Industrial Process and Laboratory Control Equipment
	NAMUR NE 43 Standardization of the Signal Level for the Failure Information of Digital Transmitters
WHG Z-65.16-425	In conformity with the German Federal Water Act, §9
CRN	This certification is for all Canadian provinces and territories. For more data, refer to the website.
Construction code	Option: NACE MR0175 / NACE MR0103 / ISO 15156

- ① The device has a distance piece if it has the flange options that follow: DN100 PN100, DN150 PN63 or PN100, DN200 PN40, 6" in 300 lb, 3"...4" in 600 lb, 3"...4" in 900 lb, and 1½"...2" in 900 lb or 1500 lb
- ② This option is not available for FM- or CSA-approved devices
- ③ Hastelloy® is a registered trademark of Haynes International, Inc.
- ④ Kalrez® is a registered trademark of DuPont Performance Elastomers L.L.C.
- ⑤ Metaglas® is a registered trademark of Herberts Industrieglas, GMBH & Co., KG
- ⑥ Tri-Clamp® is a registered trademark of Ladish Co., Inc. BioControl® is a registered trademark of Neumo-Ehrenberg-Group. VARIVENT® is a registered trademark of GEA Tuchenhausen GmbH.
- ⑦ HART® is a registered trademark of the HART Communication Foundation
- ⑧ Ex ia and Ex iaD approvals are pending for the hygienic antenna option
- ⑨ This approval does not include the hygienic antenna option



KROHNE product overview

- Electromagnetic flowmeters
- Variable area flowmeters
- Ultrasonic flowmeters
- Mass flowmeters
- Vortex flowmeters
- Flow controllers
- Level meters
- Temperature assemblies
- Pressure transmitters
- Analysis products
- Products and systems for the oil & gas industry
- Measuring systems for the marine industry

Head Office KROHNE Messtechnik GmbH
Ludwig-Krohne-Str. 5
47058 Duisburg (Germany)
Tel.: +49 203 301 0
Fax: +49 203 301 103 89
info@krohne.com

The current list of all KROHNE contacts and addresses can be found at:
www.krohne.com

KROHNE