

Condensed Instructions

IFC 010 C IFC 010 W

Signal converters for OPTIFLUX flowmeters

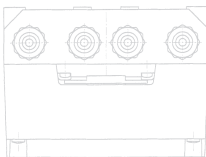
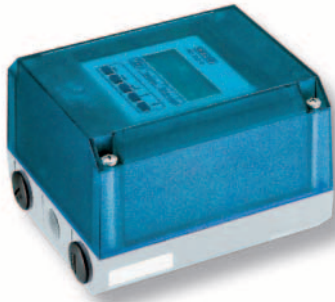

Applicable to Software-Versions

- IFC 010 _ / D
Display version
No. **806325.07**
and
No. **317551.02**
and higher
- IFC 010 _ / B
Basic version
operator-controllable
HHT 010
No. **806323.06**
and higher

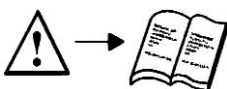

PLEASE NOTE

These concise instructions do not include the following: device description, technical data, standards, approvals, etc., nor conditions pertaining to product liability and warranty.

The operator is, however, obligated to take note of these sections in the detailed Installation and Operating Instructions.

Subject to change without notice.

Variable area flowmeters

Vortex flowmeters

Flow controllers

Electromagnetic flowmeters

Ultrasonic flowmeters

Mass flowmeters

Level measuring instruments

Communications technology

Engineering systems & solutions

Switches, counters, displays and recorders

Heat metering

Pressure and temperature

Contents

1	Electrical connection: power supply	3
1.1	Important installation notes	3
1.1.1	Location	3
1.1.2	Only for separate systems/signal converters (W versions)	3
1.1.3	Cable entries	3
1.2	Connection to power	4
1.3	Electrical connection of separate flow sensor (W Versions)	5
1.3.1	General information on signal cable A and field current cable C	5
1.3.2	Grounding of flow sensor	5
1.3.3	Cable preparation	5
1.3.4	Cable lengths (max. distance between signal converter and flow sensor)	6
1.3.5	Connection diagrams I and II (power supply, converter and flow sensor)	7
2	Electrical connection of outputs	8
2.1	Current output I	8
2.2	Pulse output P and status output S	8
2.3	Connection diagrams for outputs	9
3	Start-up	10
3.1	Powering up and measurement	10
3.2	Factory settings	10
4	Operation of the signal converter	12
4.1	Operating concept	12
4.2	Table of settable functions	13
4.3	Error messages in measuring mode	16
	Return a device for testing or repair to KROHNE	19

1 Electrical connection: power supply

1.1 Important installation notes



1.1.1 Location

Electrical connection in accordance with VDE 0100 "Regulations governing heavy-current installations with line voltages up to 1000 V" or **equivalent national regulations**.

Do not cross or loop **cables inside the terminal compartment**.

Use **separate cable entries** (see below) for power supply, field current cables, signal lines, outputs and inputs.

Protect flowmeters or switchgear cabinets with built-in devices from direct **sunlight**. Fit a sunshade if necessary.

When installed in cabinets, signal converters must be adequately cooled, e.g. use fans or heat exchangers.

Do not expose signal converters to intense **vibration**.

1.1.2 Only for separate systems/signal converters (W versions)

Keep **distance between flow sensor and signal converter** as short as possible. See Sect. 1.3.4 for maximum permissible length of signal and field current cables.

Use the supplied **KROHNE signal cable A** (Type DS), standard length 5 m (16 ft).

Always **calibrate** flow sensor and signal converter **together**. Therefore, when installing, ensure **primary constant GKL is identical**; see instrument nameplate for the flow sensor. If the GKL is not identical, set the signal converter to the GKL of the flow sensor. Refer also to Sections 4.

1.1.3 Cable entries



NOTE:

Ensure gaskets are fitted correctly and maintain the following max. torques!

- 1 Max. torques for M 20,
1/2" NPT or 1/2" PF adapters: **4 Nm / 2.8 ft × lbf**
- 2 Max. torques for M 20 only: **3 Nm / 2.1 ft × lbf**
- 3 Gasket

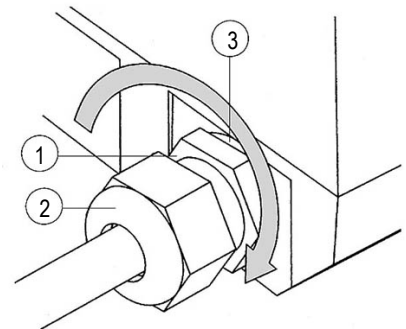

A) M 20 cable entries

These cable entries may only be used for flexible electrical cables if the relevant electrical regulations so allow, e.g. National Electric Code (NEC).

Do not fix rigid metal conduits (IMC) or flexible plastic conduits to the M 20 cable entries, refer to "Point B, C" below (1/2" NPT or PF adapters).

B) 1/2" NPT adapters

C) 1/2" PF adapters

For most North American systems the regulations require that electrical conductors be laid in conduits, particularly for power voltages > 100 V AC.

In such cases, use the 1/2" NPT or 1/2" PF adapters to which flexible plastic conduits can be screwed. Do not use rigid metal conduits (IMC)!

Lay conduits such that no moisture can penetrate into the converter housing.

Should there be risk of any condensation water forming, inside cross-section of the conduit around the cables at these adapters with a suitable sealing compound.

1.2 Connection to power



Rated values: The flowmeter housings protecting the electronic equipment from dust and moisture must always be kept closed. The selected creepage distances and clearances have been sized in conformity with VDE 0110 and IEC 664 for contamination category 2. Supply circuits and output circuits are designed to meet the standards of overvoltage classes III and II, respectively.

Safety isolation: the flowmeters (signal converters) must be provided with an isolating facility.

1. AC Version
230/240 V AC (200 - 260 V AC)
 switchable to
115/120 V AC (100 - 130 V AC)

2. AC Version
200 V AC (170 - 220 V AC)
 switchable to
100 V AC (85 - 110 V AC)

Note information on instrument nameplate: supply voltage and frequency

The **PE protective ground conductor** for the power supply **must be connected** to the separate U-clamp terminal in the terminal compartment of the signal converter. For exceptions (compact systems), refer to installation instructions for the flow sensor.

Connection diagrams I and II for electrical connection between flow sensor and signal converter: refer to Section 1.3.5.

3. AC Version
48 V AC (41 - 53 V AC)
 switchable to
24 V AC (20 - 26 V AC)

DC Version
24 V DC (11-32 V DC)

Note information on instrument nameplate: supply voltage and frequency.

For measurement reasons, connect an **FE functional ground conductor** to the separate U-clamp terminal in the terminal compartment of the signal converter.

If connected to a functional extra-low voltage source (24 V AC / DC, 48 V AC), provide for **protective separation (PELV)** in conformity with VDE 0100 / VDE 0106 or IEC 364 / IEC 536, or equivalent national regulations.

Connection diagrams I and II for power supply and electrical connection between flow sensor and signal converter: refer to Section 1.3.5.

Connection to power

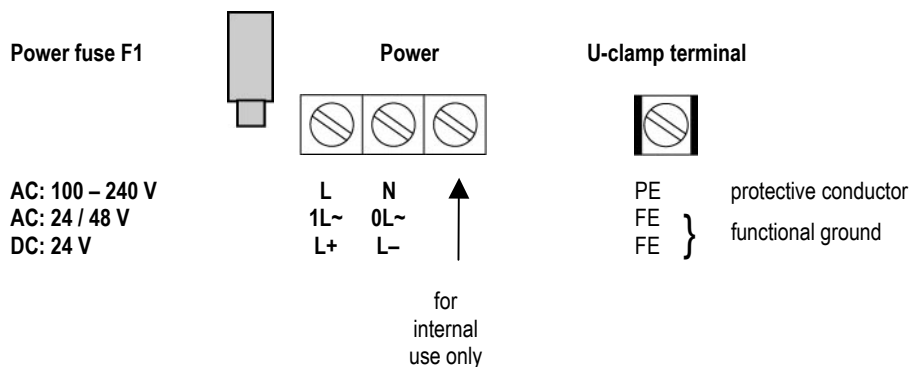

Warning:
 Instrument must be properly grounded to avoid electrical shock.

1.3 Electrical connection of separate flow sensor (W Versions)

1.3.1 General information on signal cable A and field current cable C

Use of the KROHNE shielded signal cable type DS with foil screen and magnetic shield will ensure proper operation of the equipment.

Signal cable to be permanently laid.
 Connect shields via stranded drain wires.
 Underwater and underground installation possible.
 Insulating material is flame-retardant to IEC IEC 332.1 / VDE 0742.
 Signal cables are low in halogen, unplasticized, and stay flexible at low temperatures.

Signal cable Type DS, with double shielding

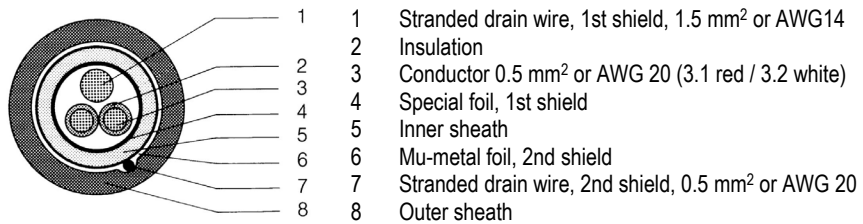

Field current cable C with single shielding

Cross-section is dependent on required length of cable, see Table in Sect. 1.3.4.

1.3.2 Grounding of flow sensor

All flowmeters must be properly grounded.
 The grounding conductor should not transmit any interference voltages.
 Do not ground any other electrical device together with this conductor.
 The flow sensor is connected to ground by means of an **FE functional ground conductor**.
 Special information on grounding various flow sensors is contained in the separate **installation instructions for flow sensors**.
 These instructions also contain detailed descriptions on how to use grounding rings and how to install flow sensors in metal or plastic pipes or internally coated pipelines.

1.3.3 Cable preparation

Customer-supplied materials	
W	Insulation tubing (PVC), Ø 2.0-2.5 mm (dia. 1")
X	Heat-shrinkable tubing or cable sleeve
Y	Wire end sleeve to DIN 41 228: E 1.5-8
Z	Wire end sleeve to DIN 41 228: E 0.5-8

Preparation for connection to flow sensor

Length	Ferrule	
	mm	inch
a	55	2.17
b	10	0.39
c	15	0.59
d	8	0.30

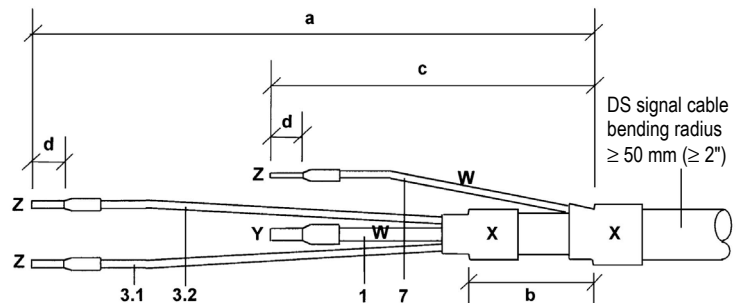

Preparation for connection to IFC 010 W signal converter

Length	Ferrule	
	mm	inch
a	90	3.60
b	8	0.30
c	25	1.00
d	8	0.30

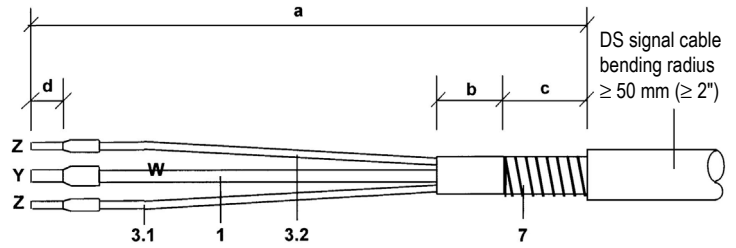

External shielding of DS signal cable

Wrap stranded drain wire (7) around the metal foil and clamp under the shield terminal in the signal converter terminal box.

1.3.4 Cable lengths (max. distance between signal converter and flow sensor)

Abbreviations and explanatory notes

used in the following tables, diagrams and connection diagrams

- C** Field current cable C, with single shielding, type and length see Table
- D** High-temperature silicone cable, $3 \times 1.5 \text{ mm}^2$ (14 AWG) Cu, with single shielding, max. length 5 m (16 ft)
- E** High-temperature silicone cable, $2 \times 1.5 \text{ mm}^2$ (14 AWG) Cu, max. length 5 m (16 ft)
- L** Cable length
- CB** Intermediate connection box required in connection with cables D and E for flow sensors OPTIFLUX 4000 F, 5000 F and 6000 F in cases where process temperatures exceed $150 \text{ }^\circ\text{C}$ ($302 \text{ }^\circ\text{F}$)

Recommended length of signal cable

for magnetic field frequency $\leq 1/6 \times$ power frequency

Flow sensor	Meter size		Signal cable
	DN mm	inch	
OPTIFLUX 1000 F	10 – 15	$\frac{3}{8}$ – $\frac{1}{2}$	DS A4
	25 – 150	1 – 6	DS A3
AQUAFLUX F	10 – 1000	$\frac{3}{8}$ – 40	DS A1
OPTIFLUX 4000 F	10 – 150	$\frac{3}{8}$ – 6	DS A2
	200 – 1000	8 – 40	DS A1
OPTIFLUX 5000 F	4.5 – 15	$\frac{1}{8}$ – $\frac{1}{2}$	DS A4
	25 – 100	1 – 4	DS A2
OPTIFLUX 6000 F	10 – 15	$\frac{1}{8}$ – $\frac{1}{2}$	DS A4
	25 – 80	1 – 3	DS A4

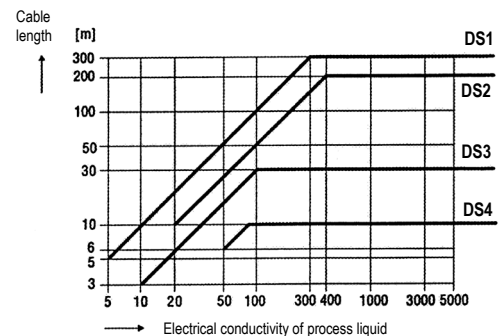
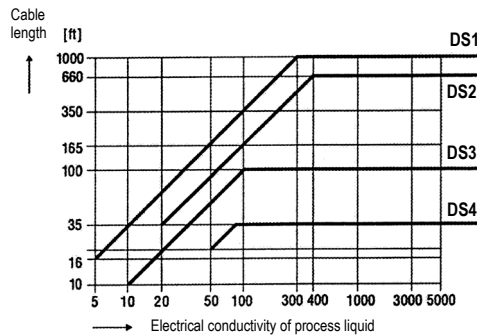

Field current cable C: max. length and min. cross-section

Length		Type of cable, single shielding
0 - 150 m	5 - 500 ft	$2 \times 0.75 \text{ mm}^2$ Cu / 2×18 AWG
150 - 300 m	500 - 1000 ft	$2 \times 1.50 \text{ mm}^2$ Cu / 2×14 AWG



Warning:

Instrument must be properly grounded to avoid electrical shock.

1.3.5 Connection diagrams I and II (power supply, converter and flow sensor)



The figures in brackets indicate the stranded drain wires for the shields, as shown in cross-sectional drawing of signal cable.

Electrical connection to VDE 0100 "Regulations governing heavy-current installations with line voltages up to 1000 V" or equivalent national regulations.

Power supply 24 V AC / DC: functional extra-low voltage with protective separation in conformity with VDE 0100, Part 410 or equivalent national regulations.

FE = functional ground conductor

I Process temperature < 150°C / 302°F

II Process temperature > 150°C / 302°F

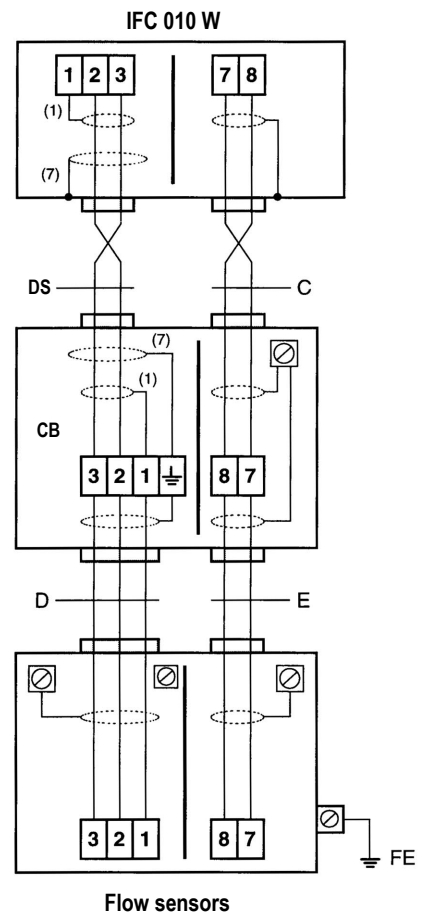
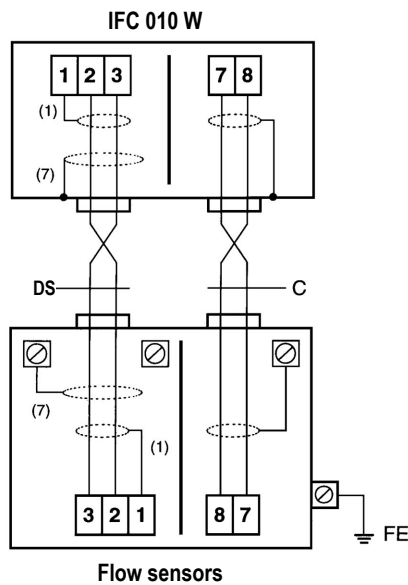

Connection of shields to the IFC 010

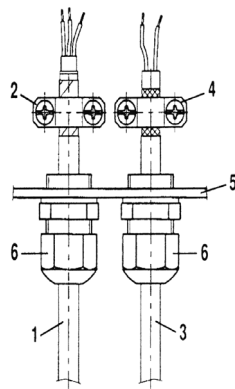

- 1 DS Signal cable
- 2 Shield terminal for shielded signal cable
- 3 Field power cable
- 4 Shield terminal for shielded field power cable
- 5 Housing wall, signal converter
- 6 Cable entries

2 Electrical connection of outputs

2.1 Current output I

- The current output is galvanically isolated from all input and output circuits.

- Typical current output

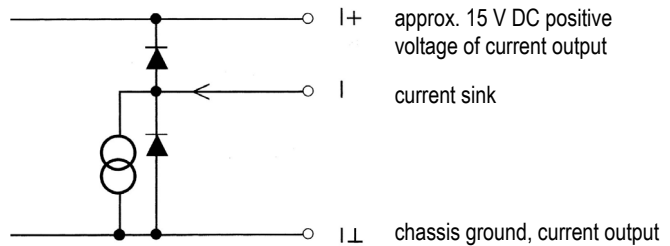

- The current output can also be used as an internal voltage source for the outputs.
 $U_{int} = 15 \text{ V DC}$ $I = 23 \text{ mA}$ when operated **without** receiver instruments at the current output
 $I = 3 \text{ mA}$ when operated **with** receiver instruments at the current output
- Connection diagrams, see Sect. 2.3.

2.2 Pulse output P and status output S

- The pulse and status outputs are galvanically isolated from the current output and all input circuits.
- Typical pulse and status outputs B1

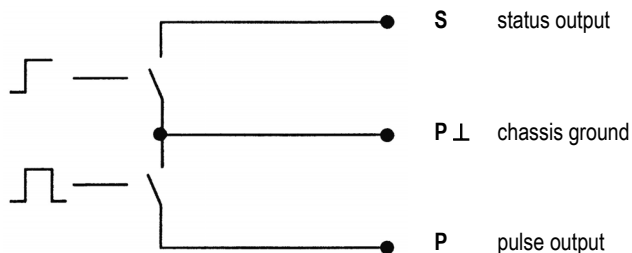



- The pulse and status outputs can be operated in the active or passive mode.
 Active mode: The current output is the internal voltage source, connection of electronic totalizers
 Passive mode: External DC or AC voltage source required, connection of electronic or electromechanical totalizers

Digital pulse division, interpulse period is non-uniform. Therefore, if frequency meters or cycle counters are connected, allow for minimum counting interval:

$$\text{gate time, counter} \leq \frac{10.000}{P_{100\%} [\text{Hz}]}$$

2.3 Connection diagrams for outputs

 DC voltage, external power source (U_{ext}), note connection polarity

 External voltage source (U_{ext}), DC or AC voltage, connection polarity arbitrary

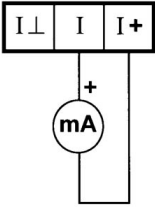
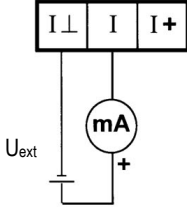
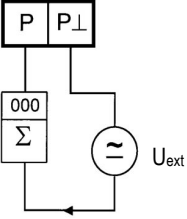
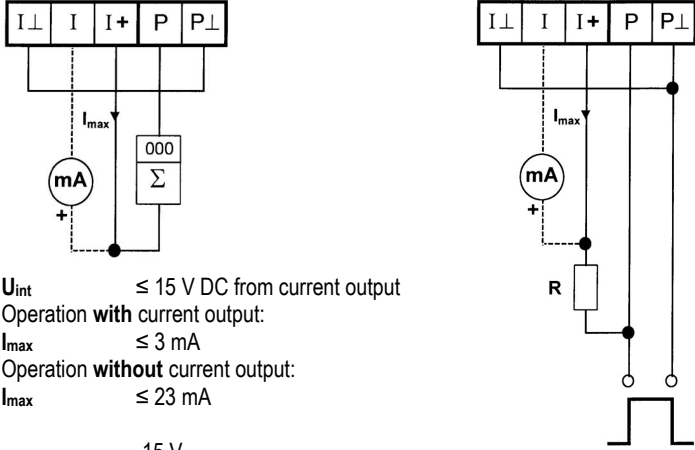
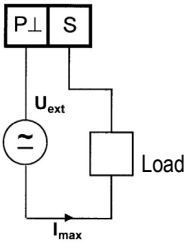
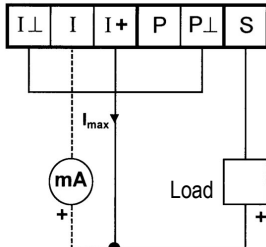
<p>① Current output <i>I_{active}</i></p>  <p>$I = 0/4 - 20 \text{ mA}$ $R_i \leq 500 \Omega$</p>	<p>② Current output <i>I_{passive}</i></p>  <table border="1"> <tr> <td>$I = 0/4 - 20 \text{ mA}$</td> <td></td> </tr> <tr> <td>$U_{ext} = 15 \dots 20 \text{ V DC}$</td> <td>$20 \dots 32 \text{ V DC}$</td> </tr> <tr> <td>$R_i = 0 \dots 500 \Omega$</td> <td>$250 \dots 750 \Omega$</td> </tr> </table>	$I = 0/4 - 20 \text{ mA}$		$U_{ext} = 15 \dots 20 \text{ V DC}$	$20 \dots 32 \text{ V DC}$	$R_i = 0 \dots 500 \Omega$	$250 \dots 750 \Omega$	<p>Active mode The current output supplies the power for operation of the outputs.</p> <p>Passive mode External power source required for operation of the outputs.</p>
$I = 0/4 - 20 \text{ mA}$								
$U_{ext} = 15 \dots 20 \text{ V DC}$	$20 \dots 32 \text{ V DC}$							
$R_i = 0 \dots 500 \Omega$	$250 \dots 750 \Omega$							
<p>③ Pulse output <i>P_{passive}</i> for electronic or electromechanical totalizers</p>  <p>$U_{ext} \leq 32 \text{ V DC} / \leq 24 \text{ V AC}$ $I_{max} \leq 150 \text{ mA}$ (incl. status output)</p>	<p>④ Pulse output <i>P_{active}</i> (and current output <i>I_{active}</i>) for electronic (EC) totalizers with and without current output I</p>  <p>$U_{int} \leq 15 \text{ V DC}$ from current output</p> <p>Operation with current output: $I_{max} \leq 3 \text{ mA}$</p> <p>Operation without current output: $I_{max} \leq 23 \text{ mA}$</p> <p>$R \leq \frac{15 \text{ V}}{I_{max}}$</p>							
<p>⑤ Status output <i>S_{passive}</i></p>  <p>$U_{ext} \leq 32 \text{ V DC} / \leq 24 \text{ V AC}$ $I_{max} \leq 150 \text{ mA}$ (incl. status output)</p>	<p>⑥ Status output <i>S_{active}</i> with and without current output I</p>  <p>$U_{int} \leq 15 \text{ V DC}$ from current output</p> <p>$I_{max} \leq 3 \text{ mA}$ Operation with current output</p> <p>$I_{max} \leq 23 \text{ mA}$ Operation with current output</p>							

3 Start-up

3.1 Powering up and measurement







The flowmeter is delivered ready for use. All operating data have been factory set in accordance with your specifications.

Power the unit, and the flowmeter will immediately start process flow measurement.

Basic version, signal converter IFC 010 _ / B

A light emitting diode (LED) under the cover of the electronic section shows the measurement status.

LED flashing . . .

		green:	measurement correct, everything all right.
		green / red:	momentary overdriving of outputs and/or A/D converter.
		red:	fatal error, parameter error or hardware fault, please consult factory.

Display version, signal converter IFC 010 _ / D

When powered, the display shows in succession: START UP and READY.

This is followed by display of the current flow rate and/or the current totalizer count on either a continuous or alternating basis, depending on the setting under Fct. 1.04.

3.2 Factory settings

All operating data are factory set according to your order specifications.

If you have not made any particular specifications at the time of ordering, the instruments will be delivered with the standard parameters and functions listed in the Table below.

To facilitate easy and rapid initial start-up, current output and pulse output are set to process flow measurement in "2 flow directions", so that the current flowrate is displayed and the volumetric flow counted independent of the flow direction. On instruments equipped with a display, measured values may possibly be shown with a "–" sign.

This factory setting for the current and pulse outputs may possibly lead to measuring errors, particularly in the case of volume flow counting:

For example, if pumps are switched off and a "backflow" occurs which is not within the range of the low-flow cutoff, or if separate displays and counts are required for both flow directions.

To avoid faulty measurements, it may therefore, be necessary to change the factory settings of some or all of the following functions:

- low-flow cutoff, Fct. 1.03
- current output I, Fct. 1.05
- pulse output P, Fct. 1.06
- display (option), Fct. 1.04

Standard factory settings

Function		Setting
1.01	Full-scale range $Q_{100\%}$	see nameplate
1.02	Time constant	3 s, for I, S and display
1.03	Low-flow cutoff	ON: 1 % OFF: 2 %
1.04	Display (option) flow rate Totalizer(s)	m^3/hr or US Gal/min m^3 or US Gal
1.05	Current output I function range error message	2 directions 4 – 20 mA 22 mA
1.06	Pulse output P function pulse value pulse width	2 directions 1 pulse/s 50 ms
1.07	Status output P	Flow direction
3.01	Language for display only	English
3.02	Flowmeter diameter flow direction (see arrow on flow sensor)	see nameplate + direction
3.04	Entry code	no
3.05	User unit	Liter/hr or US Mgal/day

4 Operation of the signal converter

4.1 Operating concept

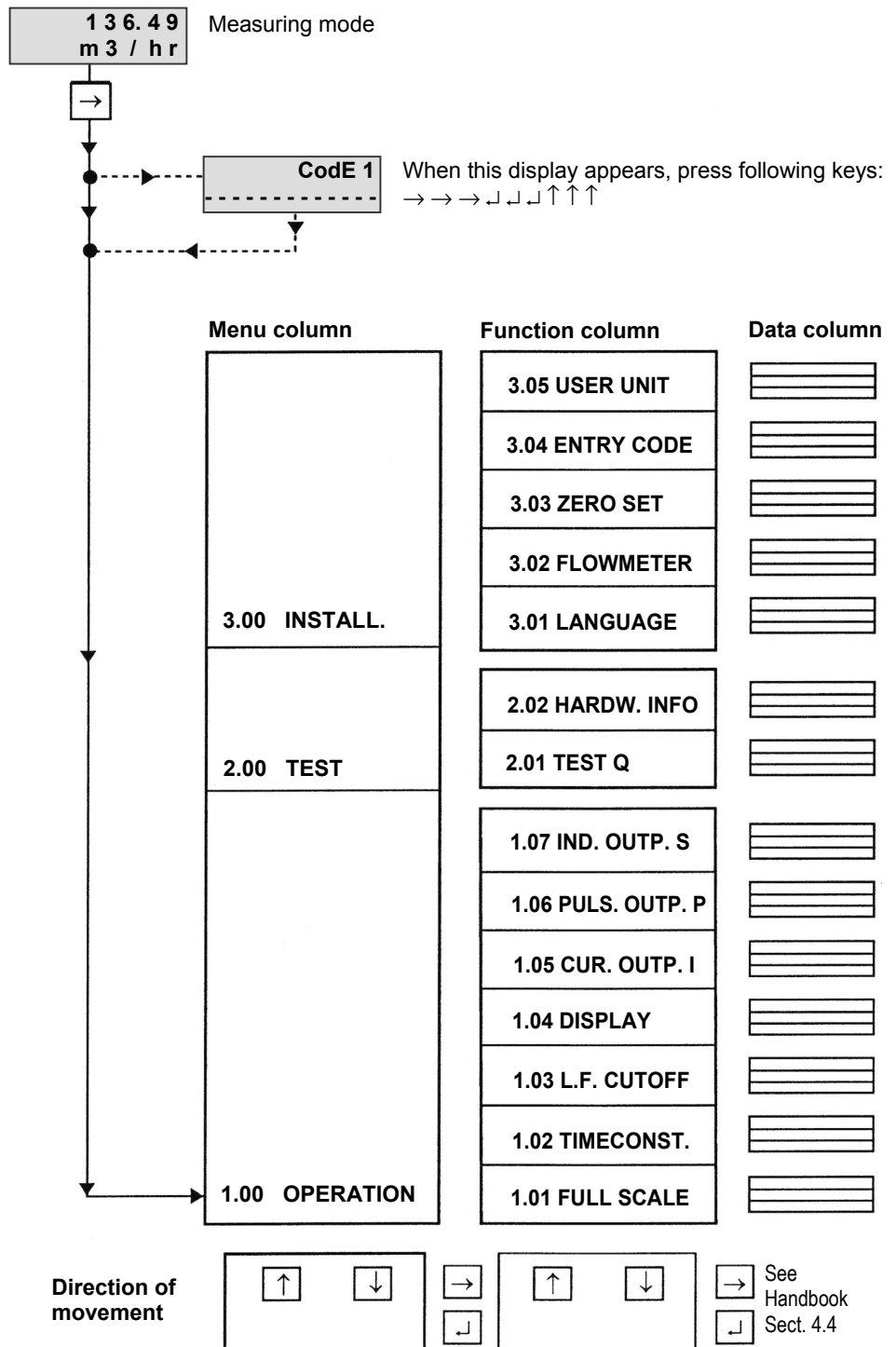

Function	Text	Description and settings
1.05	CURRENT I	Current output I
	→ FUNCT. I	Select function for current output I <ul style="list-style-type: none"> • OFF (switched off) • 1 DIR. (1 flow direction) • 2 DIR. (forward/reverse flow, F/R flow measurement)
	→ RANGE I	Select measuring range <ul style="list-style-type: none"> • 0 - 20 mA • 4 - 20 mA (fixed ranges)
	→ I ERROR	Select error value <ul style="list-style-type: none"> • 0 mA • 3.6 mA (only with range 4-20 mA) • 22 mA
1.06	PULS.OUTP. P	Pulse output P
	→ FUNCTION P	Select function for pulse output P <ul style="list-style-type: none"> • OFF (switched off) • 1 DIR. (1 flow direction) • 2 DIR. (forward/reverse flow, F/R measurement)
	→ SELECT P	Select pulse type <ul style="list-style-type: none"> • 100 Hz • PULSE/VOL. (pulses per unit volume, flow rate) • 1000 Hz • PULSE/TIME (pulses per unit time for 100% flowrate)
	→ PULSWIDTH	Select pulse width <ul style="list-style-type: none"> • 50 mSec • 100 mSec • 200 mSec • 500 mSec • 1 Sec
	→ VALUE P	Set pulse value per unit volume (appears only when "PULSE/VOL." has been set under "SELECT P") <ul style="list-style-type: none"> • xxxx PulS/m³ • xxxx PulS/Liter • xxxx PulS/US.Gal • xxxx PulS/ user unit, factory set is "Liter" or "US MGal" (see Fct. 3.05).
→ VALUE P	Set pulse value per unit time (appears only when „PULSE/TIME“ has been set under „SELECT P“). <ul style="list-style-type: none"> • xxxx PulS/Sec (=Hz) • xxxx PulS/min • xxxx PulS/hr • xxxx PulS/user unit, factory set is "hr" or "day" (see Fct. 3.05) 	
1.07	IND. OUTP. S	Status output S <ul style="list-style-type: none"> • ALL ERROR • FATAL ERROR • OFF • ON • F/R INDIC. (F/R indication for forward/reverse measurement) • TRIP. POINT Setting range: 002 - 115 PERCENT • EMPTY PIPE (appears only when this option is installed)
2.00	TEST	Test menu
2.01	TEST Q	Test measuring range Q <u>Precautionary query</u> <ul style="list-style-type: none"> • SURE NO <i>Press ↵ key to return to Fct. 2.01 "TEST Q".</i> <ul style="list-style-type: none"> • SURE YES <i>Press ↵ key, then use ↑ or ↓ key to select value:</i> -110 / -100 / -50 / -10 / 0 / +10 / +50 / +100 / +110 PCT.
	HARDW. INFO	Hardware information and error status Before consulting factory, please note down all 6 codes.
	→ MODUL ADC	X . X X X X X . X X Y Y Y Y Y Y Y Y Y Y
	→ MODUL IO	X . X X X X X . X X Y Y Y Y Y Y Y Y Y Y
	→ MODUL DISP.	X . X X X X X . X X Y Y Y Y Y Y Y Y Y Y

Function	Text	Description and settings
3.00	INSTALL.	Installation menu
3.01	LANGUAGE	Select language for display texts <ul style="list-style-type: none"> • GB / USA (English) • F (French) • D (German) • others on request
3.02	FLOWMETER	Set data for flow sensor
	→ DIAMETER	Select size from meter size table <ul style="list-style-type: none"> • DN 10 - 1000 mm or $\frac{3}{8}$ - 40 inch
	→ FULL SCALE	Full-scale range for flow $Q_{100\%}$ To set, refer to Fct. 1.01 "FULL SCALE" above.
	→ VALUE P	Pulse value (Fct. 1.06 "VALUE P") has been changed.
	→ GKL VALUE	Set primary constant GKL see flow sensor typeplate. Range: • 1.0000 - 9.9999
	→ FIELD FREQ.	Magnetic field frequency Values: 1/6 or 1/18 of power frequency, see typeplate.
	→ LINE FREQ.	Normal line frequency in your country Please note: This function is only provided for units with DC power supply to suppress line-frequency interference. Values: 50 Hz and 60 Hz
	→ FLOW DIR.	Define flow direction (in F/R mode: forward flow). Set according to direction of arrow on flow meter: • + DIR. • - DIR.
3.03	ZERO SET	Zero calibration Note: Carry out only at "0" flow and with completely filled measuring tube! <u>Precautionary query</u> <ul style="list-style-type: none"> • CALIB. NO • CALIB. YES • STORE NO • STORE YES
3.04	ENTRY CODE	Entry code required to enter setting mode? <ul style="list-style-type: none"> • NO (= entry with → only) • YES (= entry with → and Code 1: → → → ↓ ↓ ↓ ↑ ↑ ↑)
3.05	USER UNIT	Set any required unit for flowrate and counting
	→ TEXT VOL.	Set text for required flowrate unit (max. 5 characters) Factory-set: "Liter" or "MGal". <u>Characters assignable to each place:</u> • A-Z, a-z, 0-9, or " - " (= blank character).
	→ FACT. VOL.	Set conversion factor (F_M) for volume Factory set "1.00000" for "Liter" or "2.64172E-4" for "US MGal" (exponent notation, here: 1×10^3 or 2.64172×10^{-4}). <u>Factor F_M = volume per $1m^3$.</u> <u>Setting range</u> • 1.00000 E-9 to 9.99999 E+9 (= 10^{-9} to 10^{+9})
	→ TEXT TIME	Set text for required time unit (max. 3 characters) Factory-set: "hr" or "day": <u>Characters assignable to each place:</u> • A-Z, a-z, 0-9, or " - " (= blank character).
	→ FACT. TIME	Set conversion factor (F_T) for time Factory-set: "3.60000 E+3" for "hour" or "8.64000 E+4" for "day" (exponent notation, here: 3.6×10^3 or 8.64×10^4). <u>Set factor F_T in seconds.</u> <u>Setting range</u> • 1.00000 E-9 to 9.99999 E+9 (= 10^{-9} to 10^{+9})
3.06	APPLICAT.	Set overload point for A/D converter
	→ EMPTY PIPE	Switch on "empty tube" identifier option? (appears only when this option is installed) • YES • NO

4.3 Error messages in measuring mode

The following list gives all errors that can occur during process flow measurement. Errors shown in display when "YES" set in Fct. 1.04 DISPLAY, subfunction "DISP. MSG."

Error messages	Description of error	Error clearance
LINE INT.	Power failure Note: no counting during power failure	Cancel error in RESET/QUIT. Menu Reset totalizer if necessary.
CUR. OUTP. I	Current output overranged.	Check and if necessary correct instrument parameters. After elimination of cause, error message deleted automatically.
PULSOUTP. P	Pulse output overranged. Note: totalizer deviation possible.	Check and if necessary correct instrument parameters. After elimination of cause, error message deletes automatically.
ADC	Analog / digital converter overranged	Error message deletes automatically after elimination of cause.
FATAL. ERROR	Fatal error, all outputs set to "min. values"	Please consult factory.
TOTALIZER	Totalizer has been reset	Cancel error message in RESET/QUIT menu.
EMPTY PIPE	Pipe has run dry. Message appears only when the "empty pipe identifier" option is installed and the function is activated under Fct. 3.06 APPLICAT., submenu "EMPTY PIPE".	Fill pipe.

Notes

Notes

Return a device for testing or repair to KROHNE

This device has been carefully manufactured and tested. If installed and operated in accordance with these operating instructions, it will rarely present any problems. Should you nevertheless need to return a device for inspection or repair, please pay strict attention to the following points:

Due to statutory regulations on environmental protection and safeguarding the health and safety of our personnel, KROHNE may only handle, test and repair returned devices that have been in contact with products without risk to personnel and environment.

This means that KROHNE can only service this device if it is accompanied by the following certificate confirming that the device is safe to handle.

If the device has been operated with toxic, caustic, flammable or water-endangering products, you are kindly requested:

- to check and ensure, if necessary by rinsing or neutralizing, that all cavities are free from such dangerous substances,
- to enclose a certificate with the device confirming that is safe to handle and stating the product used.

We cannot service this device unless accompanied by such a certificate.

SPECIMEN certificate

Company: Address:

Department: Name:

Tel. No.: Fax No.:

The enclosed device

Type:

KROHNE Order No. or Series No.:

has been operated with the following liquid:

Because this liquid is water-hazardous toxic caustic flammable

we have checked that all cavities in the instrument are free from such substances /

flushed out and neutralized all cavities in the device

We confirm that there is no risk to humans or environment through any residual liquid contained in this device.

Date: Signature:

Company stamp: