



ALTOSONIC V Technical Datasheet

5-beam ultrasonic flowmeter for custody transfer of liquid hydrocarbons

- Custody transfer accuracy and repeatability
- Excellent long-term stability and high reliability; no on-site calibration required
- Multi-product with wide viscosity range, from LNG to heavy crudes



chapter 4



1	Product features	3
<hr/>		
1.1	Five-beam ultrasonic flowmeter.....	3
1.2	System components.....	4
2	Technical data	5
<hr/>		
2.1	Technical data.....	5
2.1.1	Ultrasonic flow sensor UFS V.....	7
2.1.2	Ultrasonic flow converter UFC-V.....	8
2.1.3	Ultrasonic flow processor UFP-V.....	9
2.2	Sizing.....	10
2.3	Dimensions and weights.....	11
2.3.1	Metric values for flow sensor and spool pieces.....	11
2.3.2	Imperial values for flow sensor and spool pieces.....	13
3	Installation	15
<hr/>		

1.1 Five-beam ultrasonic flowmeter

KROHNE's **ALTOSONIC V** has established itself as the standard in multi-beam custody-transfer flowmetering. The absence of obstructions or moving parts in the pipe, ensures no wear or pressure loss. This, in combination with larger meter sizes permits simplified configuration of metering systems. For example no strainers and less parallel lines are required.

Operation is maintenance free. No periodic calibration is required, drastically cutting cost for on-site equipment and procedures. This all results in considerable cost savings in both capital (CAPEX) and operation expenditure (OPEX).

New line extensions make multi-beam flow metering a more cost effective and viable alternative for low viscosity applications. There is also a line extension for extremely difficult heavy crudes.

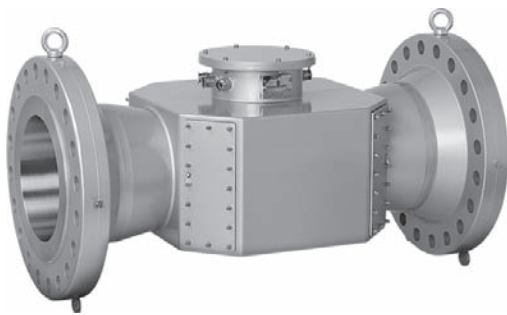

Highlights

- High reliability
- Compliant with API standards
- Certified to OIML R117 and MID MI-005
- No K-factor shift: no periodic re-calibration required
- No incidents of unscheduled interruption of operation since the introduction in 1996
- Rugged and reliable construction
- Large dynamic range
- Bi-directional flow measurement
- Integrated diagnostics

Industries

- Oil and Gas
- Refineries
- Petrochemical

Applications

- Offshore FPSO and platforms
- Production site / field
- Crude oil pipelines
- Terminal loading and off-loading
- Refineries
- Multi-product pipelines

1.2 System components

The ALTOSONIC V is more than a simple meter. It is a 3 component system:

- UFS-V, Ultrasonic Flow Sensor
- UFC-V, Ultrasonic Flow Converter
- UFP-V, Ultrasonic Flow Processor

The flow converter and flow processor are intended for controlling an ultrasonic flow sensor and processing its output signals. Equipment connected to the flow processor's input can be used to determine the volume under reference conditions and to generate indications and printouts of the measured / calculated quantities.

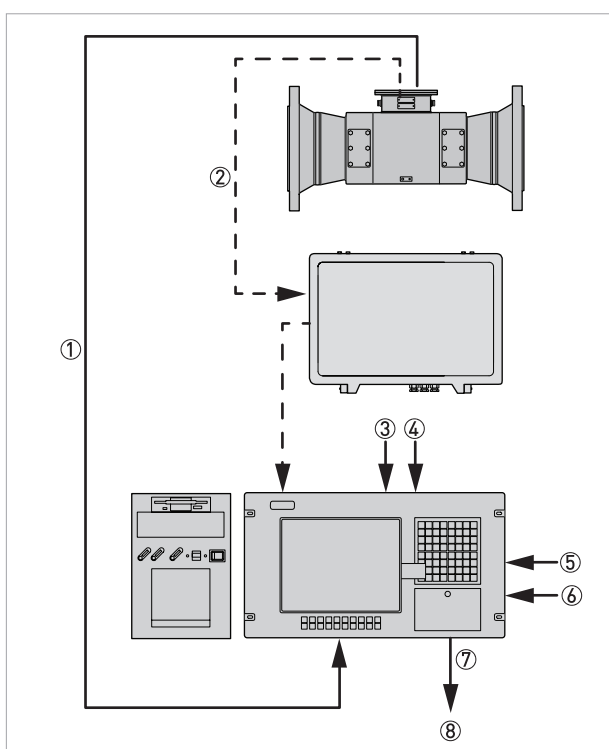

- ① Body temperature
- ② Signals from transducer
- ③ Temperature
- ④ Pressure
- ⑤ Density (optional)
- ⑥ Viscosity (optional)
- ⑦ Modbus
- ⑧ To supervisory

UFS-V, Ultrasonic Flow Sensor

Stainless steel, fully welded design which contains 5 pairs of transducers transferring signals to the flow converter. In addition, a body temperature sensor is integrated to compensate for body expansion.

UFC-V, Ultrasonic Flow Converter

For each independent measuring path, the flow converter determines the time of flight, relative flow rate per path and more, based on the received raw data from the flow sensor and transfers this information via an RS485 information string to the flow processor.

UFP-V, Ultrasonic Flow Processor

The flow processor determines the gross flow based on the information received from the flow converter. Using measured pressure, temperature, and optional density, the UFP also calculates the standard flow. The results and diagnostics are shown on-screen or fed further to the supervisory system.

Two versions are available of the processor:

- a panel-mounted version complete with HMI, and
- a compact housing for part of a system build.

2.1 Technical data

- *The following data is provided for general applications. If you require data that is more relevant to your specific application, please contact us or your local representative.*
- *Additional information (certificates, special tools, software,...) and complete product documentation can be downloaded free of charge from the website (Download Center).*

The ALTOSONIC V flowmeter consists of a flow sensor (UFS-V) with ultrasonic transducers, a separate electronic converter box (UFC-V) and a flow processor (UFP-V). The ALTOSONIC V is custom designed to optimally suit your application.

Versions

	Temperature	Viscosity
Standard	-40...+180°C / -40...+356°F	0.1...150 cSt
Extended temperature	-40...+250°C / -40...+482°F	0.1...150 cSt
High viscosity	-40...+180°C / -40...+356°F	up to 1500 cSt
Cryogenic	-200...+180°C / -328...+356°F	0.1...150 cSt

Measuring system

Measuring principle	Ultrasonic transit time
Measuring functionality	Standard actual volume flow rate and totalised volume
Measuring range	$v = 0...10 \text{ m/s}$ / $v = 0...33 \text{ ft/s}$

Accuracy

Accuracy	Turndown 1:20: $< \pm 0.15\%$ of measured value for $v = 1...10 \text{ m/s}$ / $v = 0.9...33 \text{ ft/s}$
	Turndown 1:50: $< \pm 0.20\%$ of measured value for $v = 0.2...10 \text{ m/s}$ / $v = 0.7...33 \text{ ft/s}$
Repeatability	$< \pm 0.02\%$ (n = 2)
Uncertainty	$< \pm 0.027\%$ (95% confidence level) acc. to API
Viscosity range	0.1...1500 cSt
Density range	200...1200 kg/m ³ / 12.5...75 lb/ft ³
Zero stability	$< 0.2 \text{ mm/s}$

Process conditions

Ambient temperature for all ATEX versions	-40...+60°C / -40...+140°F
Maximum solid particle content (well mixed)	$< 5\%$ (by volume)
Maximum gas content (well mixed)	$< 2\%$ (by volume)
Water in oil (well mixed)	6% at $> 1 \text{ m/s}$ / 6% at $> 3.3 \text{ ft/s}$
	10% at $> 2 \text{ m/s}$ / 10% at $> 6.6 \text{ ft/s}$

Approvals

Custody transfer	MID, Measuring Instrument Directive, MID 005, 2004/22/EC
	OIML R117 class 0.3
	"API Chapter 5.8 (Section 8, Measurement of Liquid Hydrocarbons by Ultrasonic Flowmeters Using Transit Time Technology)"
	GOST Gosstandart
	Over 20 national approvals world wide (detailed list upon request)
ATEX	
Ultrasonic flow sensor	II 2 G Ex ib IIC T6...T4/T3/T2
Ultrasonic flow converter	II 2 G Ex d [ib] IIB T5
FM	
Ultrasonic flow sensor	IS / I / 1 / ABCD / T5 Ta = 60°C - 8.30867.17, DIP-IS / II,III / EFG / T5 Ta = 60°C - 8.30867.17; Type 4
Ultrasonic flow converter	XP-AISI / I / 1 / BCD / T6 Ta = 60°C - 8.30867.17D; IP-AISI / II, III / EFG/ T6 Ta = 60°C - 8.30867.17; Type 4
CSA	
Ultrasonic flow sensor	Class I, Div. 1, Groups A, B, C and D; Class II, Groups E, F and G; Class III; Class I, Div. 2, Groups A, B, C and D; Class II, Div.2, Groups E, F and G
Ultrasonic flow converter	Class I, Groups. B, C and D; Class II, Groups E, F and G; Class III
NEPSI	
Ultrasonic flow sensor	Ex ib IIC T2-T6
Ultrasonic flow converter	Ex d[ib] IIB T5

2.1.1 Ultrasonic flow sensor UFS V

Process conditions

Nominal diameter [inch] ASME B16.5	4, 6, 8, 10, 12, 14, 16, 18, 20, 24; others on request
Nominal diameter [mm] DN	100, 150, 200, 250, 300, 350, 400, 450, 500, 600; others on request
Pressure class	150, 300, 600, 900, 1500; others on request
Calibration (optional)	Bi-directional calibration
Verification (optional)	Water: acc. to OIML R117 or API; others on request
	Hydrocarbon liquid: acc. to OIML R117 or API; others on request
	In both cases a certificate from a European Accredited Laboratory (EAL)
Protection category	IP67/IP66 eq. to NEMA4/4X/6 acc. to IEC 529

Materials

Measuring tubes	Stainless steel AISI 316 L (1.4404)
Flanges	Stainless steel AISI 316 L (1.4404)
Housing	Stainless steel AISI 316 L (1.4404)
Connection box	Stainless steel AISI 316 L (1.4404)
Finish	Standard: KROHNE standard paint, silver
	Optional: KROHNE offshore paint system, silver

Electrical connection

Sensor cable connection	Standard: M20x1.5
	Optional: ½" NPT or PF ½
Sensor cable length	Standard: 5 m / 15 ft
	Optional: 10, 15, 20, 25, 30 m / 30, 45, 60, 75, 90 ft

2.1.2 Ultrasonic flow converter UFC-V

Measuring system

Overall functionality	Measurement of all necessary primary flow data, status and diagnostic information
Versions	UFC V flow converter electronics fitted in an Ex d box
General	The flow converter is fully digital.
	Measured values are obtained using DSP (Digital Signal Processing) techniques to ensure accurate and highly repeatable measurements.
	Measured values are digitally transferred to the flow processor computer (UFP-V).

Operating conditions

Ambient temperature	ATEX housing: -20...+60°C / -4...+140°F
	ATEX (LT, cable glands): -50...+60°C / - 58...+140°F
	ATEX (LT, conduits): -55...+60°C / - 67...+140°F
	FM: -40...+60°C / -40...+140°F
Protection category	IP67/IP66 eq. to NEMA4/4X/6 acc. to IEC 529

Materials

Standard	Copper free aluminium, AISI 12 acc. to ISO 3522-81
Optional	Stainless steel 316 cover for converter housing
Finish	Standard: KROHNE standard paint, silver
	Optional: KROHNE offshore paint system, silver

Electrical connection

Cable connection	For power supply and signal cables
	Standard: M20x1.5
	Optional: ½" NPT or PF ½
Power supply	Standard: Mains supply 100...240 VAC (48...63 Hz) +10% / -15%
	Optional: Low voltage supply 24 VAC/DC, AC: -10% / +15%, DC: 18...35 V
Power consumption	Max. 36 VA (AC) or 36 W (DC)
	Optional heater connection 240/110 VAC for LT version, additional max. 200 VA/W
Output	RS485 output (to UFP-V)

2.1.3 Ultrasonic flow processor UFP-V

Measuring system

General	The flow processor receives the raw measurement values from the UFC-V flow converter and converts the data in gross volume flow and totalised gross volume.	
	Optionally volume flow and totalised volume can be calculated to standard conditions.	
	Also the flow processor provides a range of diagnostics functions.	
	The flow processor consist of an industrial PC with I/O rack to connect the necessary input and output signals.	
Primary functions	Calculation of gross volumetric flow based on flow measurements from the UFC-V	
	Calculation of standard volumetric flow (e.g. 15°C / 59°F, 1.01325 bar / 14.696 psi) and mass flow (optional)	
	Totalise gross and standard flow as measured volumes and mass in resettable and non-resettable totalisers	
	Measurement of flow profile and swirl components	
	Data acquisition: logging of data from the UFC-V and optional data such as temperatures, pressures, densities and status information	
	Body temperature expansion correction on the measured flow	
	Flow weighted averages on batching (temperature, pressure, density, etc)	
	Ticket printing	
	Real time monitoring of all data on screen	
Secondary functions	Calculation of Reynolds number and indication of viscosity	
	Statistics	
	Back-up history such as totalisers, averages and alarms	
I/O descriptions	Basic I/O	Full I/O
Digital inputs	4 x NO/NC	4 x NO/NC
Analogue inputs	1 x body temperature	16 x analogue inputs
Frequency inputs	-	2 x max. 5 kHz
Digital outputs	4 x solid state relays	4 x solid state relays
Analogue outputs	1 x free configurable	3 x free configurable
Pulse outputs	1 x dual pulse 2 kHz 90° or 180° phase shifted	1 x dual pulse 2 kHz 90° or 180° phase shifted
Serial outputs	1 x RS485/RS422/RS232 Modbus ASCII and RTU are supported; can act as Master or Slave	1 x RS485/RS422/RS232 Modbus ASCII and RTU are supported; can act as Master or Slave
Versions		
Industrial work station	Standard: PC-based industrial work station with an industrial grade 12.1" colour TFT LCD display and integrated keypad.	
	19" housing for rack mounting or front panel mounting	
Compact industrial PC	Optional: Compact industrial PC for panel / ground plate mounting. Separate display and keyboard	
Operating conditions		
Ambient temperature	Workstation and IPC: 0...+40°C / +32...+104°F	
Protection category	Industrial work station: IP65 / NEMA12 (front panel)	
	Compact industrial PC: N/A to IEC 529	

Electrical connection

Power supply	Industrial work station: Mains supply 90...135 VAC or 180...265 VAC, switchable, 110 W
	Industrial work station: Low voltage supply 24 VDC (19...32 VDC), 110 W
	Compact industrial PC: Mains supply 100...240 VAC, 110 W

2.2 Sizing

Choosing the correct size is very easy due to the extremely wide range of possible velocities. Typical flow rates for 0.2 m/s / 0.7 ft/s and 10 m/s / 33 ft/s are specified in the table below. Depending on the application, the flowmeter has a virtually unlimited flow velocity range.

Diameter [inch]	0.2 m/s	10 m/s	0.2 m/s	10 m/s	0.2 m/s	10 m/s
	0.7 ft/s	33 ft/s	0.7 ft/s	33 ft/s	0.7 ft/s	33 ft/s
	[m ³ /h]		[GPM]		[BBL/h]	
4	5.6	280	25	1230	35	1760
6	12.6	630	55	2770	80	3960
8	22.6	1130	100	4980	140	7120
10	36	1800	160	7900	225	11300
12	50	2500	220	11000	315	15700
14	70	3500	310	15400	440	22000
16	90	4500	400	19800	565	28280
18	114	5700	500	25100	715	35850
20	140	7000	616	30800	880	44000
24	200	10000	880	44000	1255	62850

2.3 Dimensions and weights

2.3.1 Metric values for flow sensor and spool pieces

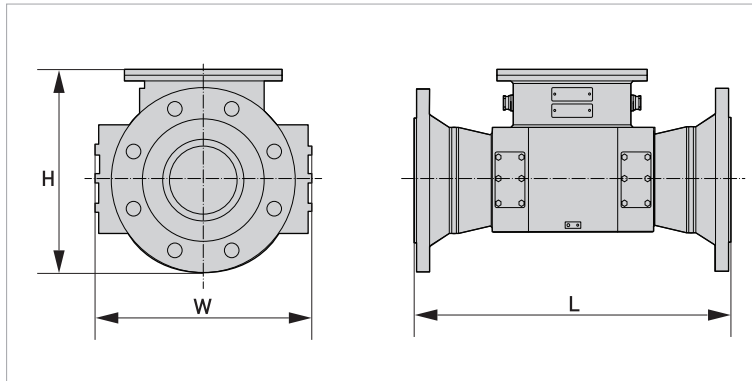

ASME 150 lbs

Flow sensor						Spool pieces				Size in DN
Size	Length L	Internal diam.	Height H	Width W	Approx. weight	10D inlet		5D outlet		
						Length	Approx. weight	Length	Approx. weight	
[inch]	[mm]				[kg]	[mm]	[kg]	[mm]	[kg]	
4	500	102	289	330	100	1000	37	500	21	100
6	600	154	340	380	110	1500	75	750	40	150
8	900	203	396	343	160	2000	140	1000	72	200
10	1000	255	453	406	230	2500	228	1250	112	250
12	1100	305	501	540	310	3000	342	1500	174	300
14	1200	337	567	600	460	3500	368	1750	225	350
16	1300	388	623	650	600	4000	574	2000	292	400
18	1400	438	668	700	860	4500	759	2250	357	450
20	1500	483	729	750	960	5000	1123	2500	438	500
24	1800	575	813	813	1050	6000	1335	3000	623	600

ASME 300 lbs

Flow sensor						Spool pieces				Size in DN
Size	Length L	Internal diam.	Height H	Width W	Approx. weight	10D inlet		5D outlet		
						Length	Approx. weight	Length	Approx. weight	
[inch]	[mm]				[kg]	[mm]	[kg]	[mm]	[kg]	
4	500	102	302	330	110	1000	46	500	29	100
6	600	154	359	380	120	1500	92	750	56	150
8	900	203	416	381	180	2000	164	1000	96	200
10	1000	255	473	445	260	2540	268	1270	152	250
12	1100	305	520	540	360	3000	389	1500	220	300
14	1200	330	583	600	460	3500	449	1750	306	350
16	1300	381	648	650	690	4000	668	2000	385	400
18	1400	435	711	700	900	4500	883	2250	481	450
20	1500	483	775	750	1120	5000	1275	2500	589	500
24	1800	575	914	813	1300	6000	1612	3000	901	600

ASME 600 lbs

Flow sensor						Spool pieces				Size in DN
Size	Length L	Internal diam.	Height H	Width W	Approx. weight	10D inlet		5D outlet		
						Length	Approx. weight	Length	Approx. weight	
[inch]	[mm]				[kg]	[mm]	[kg]	[mm]	[kg]	
4	550	97	312	330	110	1000	57	500	40	100
6	650	146	378	380	160	1500	132	750	87	150
8	950	194	434	419	260	2000	237	1000	148	200
10	1100	222	504	508	400	2500	419	1250	261	250
12	1100	289	539	559	480	3000	630	1500	360	300
16	1300	366	668	686	810	3500	1265	1750	768	350

2.3.2 Imperial values for flow sensor and spool pieces

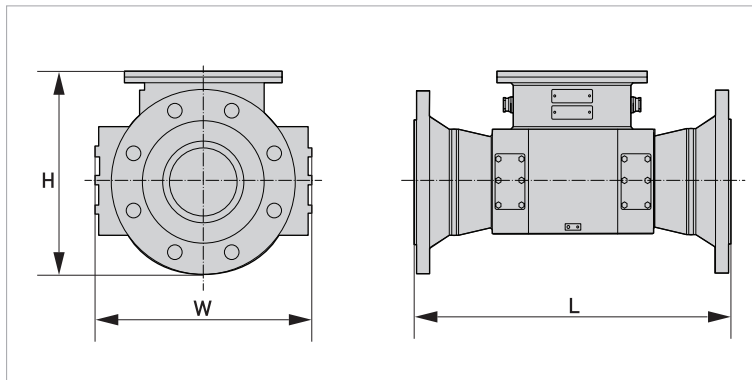

ASME 150 lbs

Flow sensor						Spool pieces			
Size	Length L	Internal diam.	Height H	Width W	Approx. weight	10D inlet		5D outlet	
						Length	Approx. weight	Length	Approx. weight
[inch]	[inch]				[lb]	[inch]	[lb]	[inch]	[lb]
4	19.69	4.02	11.38	12.99	220	40	81	20	46
6	23.62	6.06	13.39	14.96	242	60	165	30	88
8	35.43	7.99	15.59	13.50	352	80	308	40	158
10	39.37	10.04	17.83	15.98	506	100	502	50	246
12	43.31	12.01	19.72	21.26	682	120	752	60	383
14	47.24	13.27	22.32	23.62	1012	140	810	70	495
16	51.18	15.28	24.53	25.59	1320	160	1263	80	642
18	55.12	17.24	26.30	27.56	1892	180	1670	90	785
20	59.06	19.02	28.70	29.53	2112	200	2471	100	964
24	70.87	22.64	32.01	32.01	2310	240	2937	120	1371

ASME 300 lbs

Flow sensor						Spool pieces			
Size	Length L	Internal diam.	Height H	Width W	Approx. weight	10D inlet		5D outlet	
						Length	Approx. weight	Length	Approx. weight
[inch]	[inch]				[lb]	[inch]	[lb]	[inch]	[lb]
4	19.69	4.02	11.89	12.99	242	40	101	20	64
6	23.62	6.06	14.13	14.96	264	60	202	30	123
8	35.43	7.99	16.38	15.00	396	80	361	40	211
10	39.37	10.04	18.62	17.52	572	100	590	50	334
12	43.31	12.01	20.47	21.26	792	120	856	60	484
14	47.24	12.99	22.95	23.62	1012	140	988	70	673
16	51.18	15.00	25.51	25.59	1518	160	1470	80	847
18	55.12	17.13	27.99	27.56	1980	180	1943	90	1058
20	59.06	19.02	30.51	29.53	2464	200	2805	100	1296
24	70.87	22.64	35.98	32.01	2860	240	3546	120	1982

ASME 600 lbs

Sensor						Spool pieces			
Size	Length L	Internal diam.	Height H	Width W	Approx. weight	10D inlet		5D outlet	
						Length	Approx. weight	Length	Approx. weight
[inch]	[inch]				[lb]	[inch]	[lb]	[inch]	[lb]
4	21.65	3.82	12.28	12.99	242	40	125	20	88
6	25.59	5.75	14.88	14.96	352	60	290	30	191
8	37.40	7.64	17.09	16.50	572	80	521	40	326
10	43.31	8.74	19.84	20.00	880	100	922	50	574
12	43.31	11.38	21.22	22.01	1056	120	1386	60	792
16	51.18	14.41	26.30	27.01	1782	160	2783	80	1690

General

For specific information please consult the manual or contact your local sales office.

Installation position

The flowmeter can be installed in a horizontal or vertical position. In a horizontal pipeline ensure that the acoustic channels are always in an horizontal plane.

Flow conditions

Completely filled flow sensor: Install the ultrasonic flow sensor at a location where it will be completely filled under all circumstances, including at zero flow velocity.

Zero checking

Zero setting is not required with our ultrasonic flowmeters. For zero checking it is advised to install shut-off valves before or after the flow sensor.

Cavitation

At operation sufficient backpressure is required to prevent cavitation.

Inlet flow conditioner and outlet section

The flow sensor is delivered standard with a 10D inlet with flow conditioner. For optimal performance the flow sensor and inlet with flow conditioner must be calibrated together.

The flow sensor has to be installed with a straight outlet section with a minimum length of 5D.

We provide a standard range of inlet flow conditioners and outlet sections with optional connections for temperature and pressure measurement.

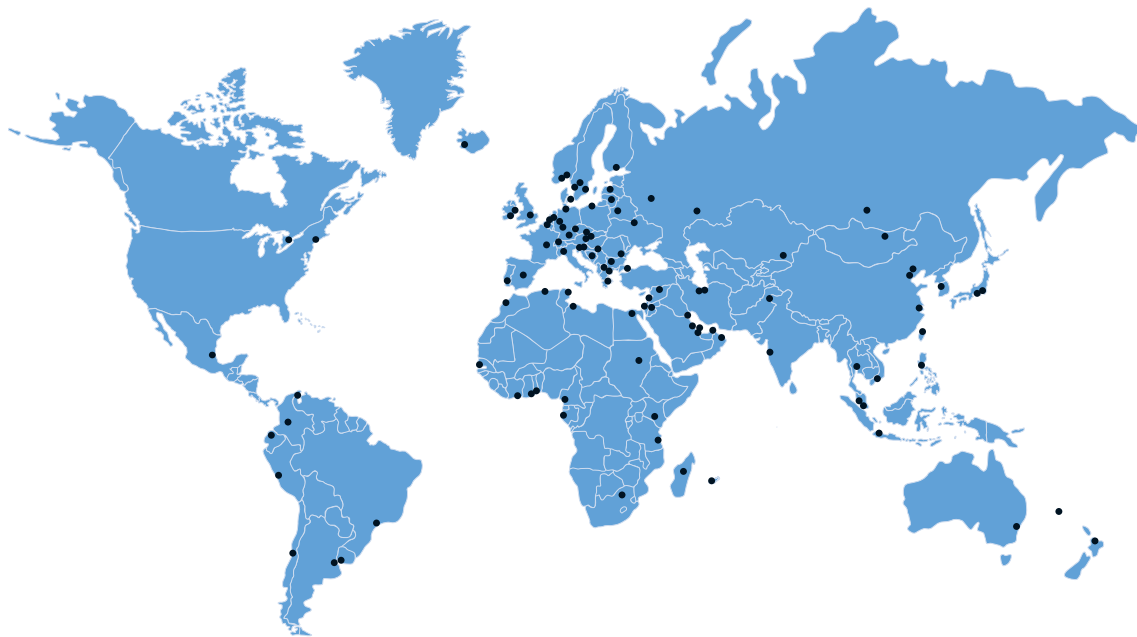

KROHNE product overview

- Electromagnetic flowmeters
- Variable area flowmeters
- Ultrasonic flowmeters
- Mass flowmeters
- Vortex flowmeters
- Flow controllers
- Level meters
- Temperature meters
- Pressure meters
- Analysis products
- Products and systems for the oil & gas industry
- Measuring systems for the marine industry

Head Office KROHNE Messtechnik GmbH
Ludwig-Krohne-Str. 5
47058 Duisburg (Germany)
Tel.: +49 (0)203 301 0
Fax: +49 (0)203 301 10389
info@krohne.de

The current list of all KROHNE contacts and addresses can be found at:
www.krohne.com

KROHNE