

UFM 3030 Universal 3-beam in-line ultrasonic flowmeter for liquids

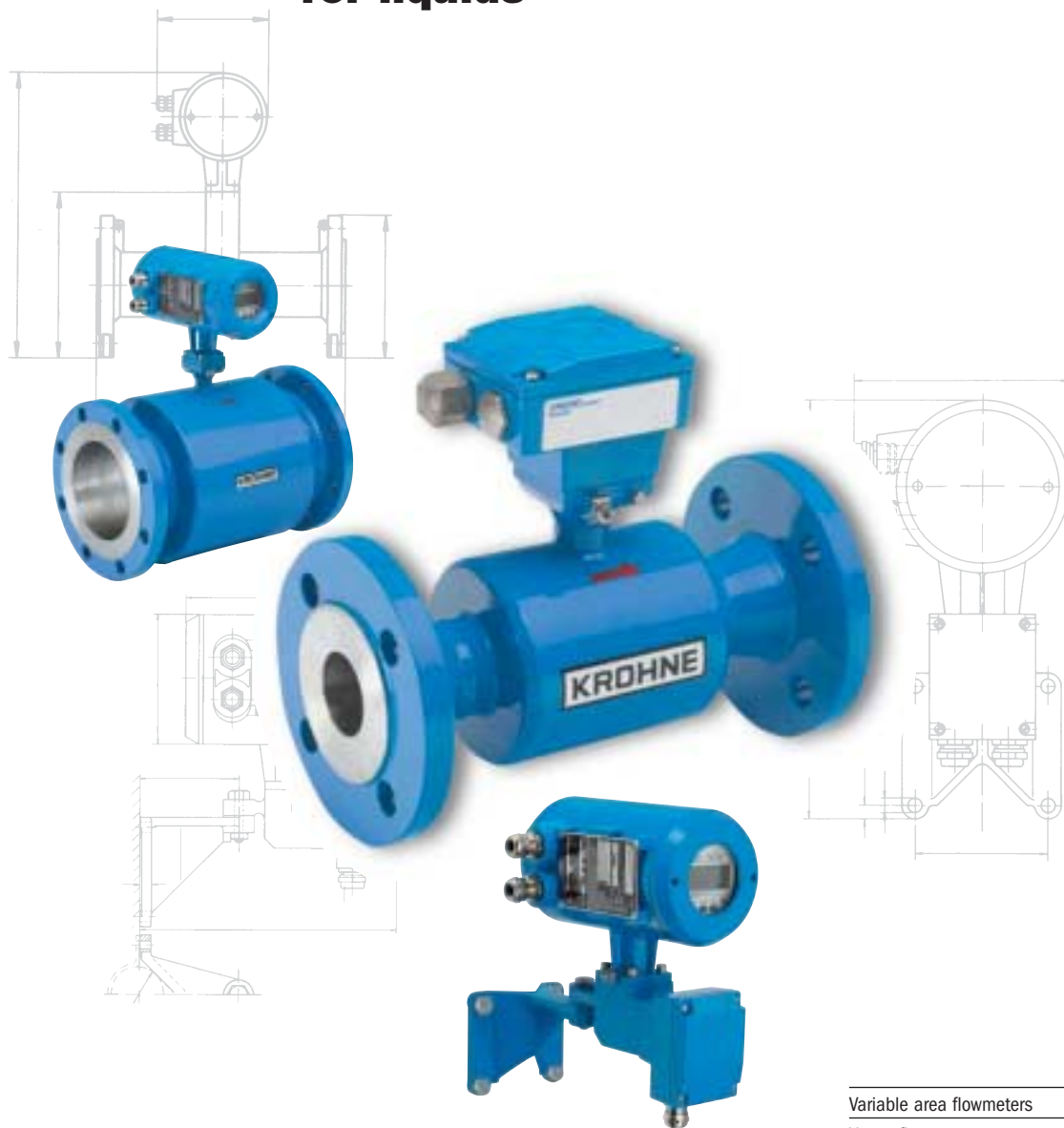

Variable area flowmeters

Vortex flowmeters

Flow controllers

Electromagnetic flowmeters

Ultrasonic flowmeters

Mass flowmeters

Level measuring instruments

Communications technology

Engineering systems & solutions

Switches, counters, displays and recorders

Heat metering

Pressure and temperature



Ultrasonic flowmeters

KROHNE has over 25 years experience in ultrasonic flow metering. Since 1980 over 30,000 KROHNE ultrasonic flowmeters have been installed in the field with reliable and trouble-free operation.

With their high level of performance, unique properties and wide application range, ultrasonic flowmeters are gaining a leading position in the global flowmeter market. The benefits provided by ultrasonic flow meters are rapidly making them indispensable solutions for industrial processes.

UFM 3030 offers all advantages of ultrasonic flowmeters. Flow measurement is independent of conductivity, viscosity, temperature, density and pressure. The unobstructed flow sensor, with smooth surface finish, inhibits any material build up. This, combined with no moving parts to wear out, provides for many years of maintenance-free service.

Universal use

UFM 3030 has a very wide application range. In industrial process applications, both acids and caustic solutions can be measured, ranging from sulfuric acid to caustic soda. Also, inorganic substances from molten sulfur to chlorine and organic substances including liquefied gasses do not cause any problems for UFM 3030.

In the oil and gas industry the applications range from heavy crude oils to bitumen and liquefied petroleum gasses (LPG's).

In the water markets UFM 3030 can be used for measuring drinking water as well as for cooling water and demineralized water.

It is KROHNE's policy to test every flowmeter that leaves our factory by means of wet calibration to guarantee the highest possible accuracy and quality standards. Therefore KROHNE owns accredited calibration rigs that comply with the most stringent demands (according to **IEC-ISO 17025**).

UFM 3030 Universal 3-beam in-line ultrasonic flowmeter for liquids

Experience a new dimension in ultrasonic technology

A new dimension in:

- Performance
- Installation
- Operational and maintenance costs
- Price

The third beam adds a new dimension!

The three measuring beams of UFM 3030 generate a 3-dimensional cross-section of the medium's velocity distribution, or flow profile, through the measuring tube. These measuring beams are positioned such that measurement is effectively independent of the flow profile.

Major performance improvements have been achieved by applying innovative electronics in combination with Digital Signal Processing (DSP). This results in stable and reliable measurements.

The meter is therefore more accurate and less sensitive to changes in the flow profile, solids or entrained air. UFM 3030 is a universal meter in a very broad range of applications.

A new feature of the UFM 3030 is the possibility to control batching operations, directly from UFM 3030. Optionally, pressure and temperature inputs can be accommodated for the calculation of standardized volumetric flow or mass flow (according to API 2540 or customer specifics).

Naturally, a complete offering of communication protocols and approvals for hazardous areas makes it possible to integrate the meter into existing systems.

Flow profile

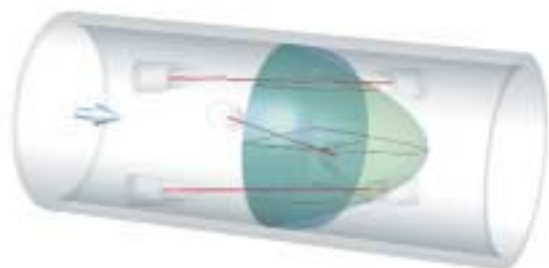

The third measuring beam allows UFM 3030 to take conditions from laminar to turbulent flow into consideration.



Step into the new dimension!



UFM 3030 exceeds your expectations in...

...Performance

UFM 3030 has a very wide application range. Three measuring beams combined with patented sensors, dedicated electronics and innovative digital signal processing techniques provide reliable, stable measurements, even under difficult process conditions. As a result, flowmeter drift and, therefore, process re-tuning has become an annoyance of the past.

...Installation

UFM 3030 is a light-weight, compact meter that is easy to install and operate. Additional arrangements such as filters, flow strainers, supports, grounding or isolation against vibrations are not necessary. Since the meter is maintenance-free, even installation in difficult to access locations is possible.

...Operational and maintenance costs

UFM 3030 has no intruding or moving parts. There is no additional pressure loss or wear and tear. Thus the meter is maintenance-free and far more energy efficient.

...Price

UFM 3030 is very attractively priced. The total costs of a measuring installation with UFM 3030 are considerably lower than those of a comparable installation of a coriolis mass or a vortex flowmeter. Moreover, one universal meter for all your applications keeps your engineering and inventory costs to a minimum.

How does UFM 3030 operate?



UFM 3030 operates like all KROHNE ultrasonic flowmeters, by the transit-time differential method. This measuring principle is based on a simple physical principle.

Imagine two canoes crossing a river diagonally, one with the flow and one against the flow. Naturally, the canoe that is travelling with the flow will reach the opposite side sooner than the canoe that is travelling upstream. Acoustic signals behave in a comparable way.

By means of 3 pairs of patented ultrasonic transducers, the transit times of acoustic signals that travel upstream and downstream are measured.

The difference in transit time is proportional to the mean flow velocity and is converted into an output signal and display of volumetric flow rate and total.

The measuring beams in a UFM 3030 make a three-dimensional cross section of the velocity distribution or flow profile of the medium flowing through the measuring tube. These measuring lines are positioned so that the influence by flow profile (laminar or turbulent) is reduced greatly. Combined with the use of the latest digital processing techniques, the results are stable and reliable flow measurements.

Day in, day out. Year in, year out. There is no drift in measurements, and repeatable process control is achieved.

Laminar flow

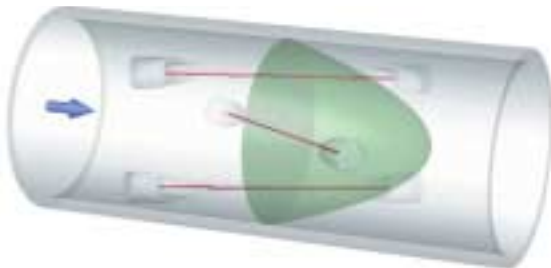

Turbulent flow

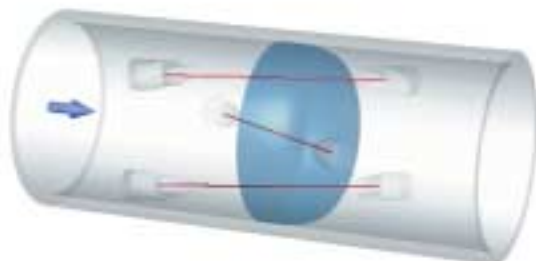

UFM 3030 Specifications

Versions

The UFS 3000 ultrasonic flow sensor is combined with the UFC 030 ultrasonic flow converter to make a complete flowmeter, the UFM 3030 ultrasonic flowmeter, either in separate or compact version. Both the sensor and the converter are approved for use in hazardous areas.

Compact Version

UFM 3030 K



UFM 3030 K

UFC 030 K ultrasonic flow converter is mounted directly on the UFS 3000 ultrasonic flow sensor
 UFM 3030 K – EEx / FM / CSA (hazardous area locations)

Separate Version

UFM 3030 F



UFS 3000 + UFC 030

UFC 030 F ultrasonic flow converter is remotely mounted from the UFS 3000 ultrasonic flow sensor
 UFM 3030 F – EEx / FM / CSA (hazardous area locations)

Measurement functionality	Standard	<ul style="list-style-type: none"> ● Actual volume with simple single stage batching function
	Optional	<ul style="list-style-type: none"> ● Corrected or standardized volume flow rate to API 2540 or customer specified ● Customer specified mass flow (requires customer data)

Process conditions	Liquids with maximum solid particle content < 5% (by volume) or maximum gas content < 2% (by volume)
---------------------------	--

Communications protocols	Standard	HART®
	Optional	Profibus PA

Measuring range	UFM 3030 measures a wide range of flow velocities, starting from v = 0 ft/s to 66 ft/s (0 m/s up to 20 m/s)
------------------------	---

Measuring accuracy (under reference conditions)	
Measuring error (v = flow velocity)	v = 1.5 to 60 ft/s (0.5 to 20 m/s) < ± 0.5% of measured value v < 1.5 ft/s (0.5 m/s) < ± 0.1 inch/s (± 2.5 mm/s) of measured value
Measuring repeatability	± 0.2% of measured value
Influence of temperature	< ± 0.1% per 18°F (10°C)

Hazardous area approvals	ATEX IEC 529-EN 60 529, EEx de ib IIC Tb ... Ts, FM Class I, Div. 1 & 2, Groups A, B, C & D Class II, Div. 1, Groups E, F & G Div. 2, Groups F & G Class III, Div. 1 & 2 CSA Class I, Div. 1 & 2, Groups A, B, C & D Class II, Div. 1 & 2, Groups E, F & G Class III, Div. 1 & 2
---------------------------------	---

Temperature limits

Compact version	
Medium temperature	-13°F to +284°F (-25°C to +140°C)
Ambient temperature	-40°F to 149°F (-40°C to +65°C)

Separate version	
Medium temperature	-13°F to +356°F (-25°C to +180 °C)
Ambient temperature	-40°F to 149°F (-40°C to +65°C)

Optional extended medium temperature	13°F to +428°F (-25°C to 220°C) up to 6 inch / DN150
Special versions	for medium temperatures ranging from -274°F to +932°F (-170°C to +500°C) available on request (HT/HP version)

Protection category	according to IEC 529 (EN 60 529)
----------------------------	----------------------------------

Standard (separate and compact versions)	IP 67 (equivalent to NEMA 6 and 6P)
Optional for separate version	IP 65 (equivalent to NEMA 4 and 4X) or IP 68 (equivalent to NEMA 6 and 6P)

UFS 3000 Ultrasonic Flow Sensor

Flange connections

Diameter	Pressure rating / flange class*	Max. Pressure	Rating
To DIN 2501			
DN 25 - 80	PN 40	40 bar	580 psig
DN 100 - 150	PN 16	16 bar	230 psig
DN 200 - 2000	PN 10	10 bar	15 psig
DN 1200 - 2000	PN 6	6 bar	90 psig
DN 2200 - 3000	PN 2.5	2.5 bar	70 psig
To ANSI B 16.5			
1" - 24"	ANSI - Class 150 lb / RF	19.7 bar at 20°C	285 psig at 68°F
26" - 40"	MSS-SP44 - Class 150 lb / RF	19.7 bar at 20°C	285 psig at 68°F
To AWWA			
24" - 120"	ANSI - Class 150 lb / RF	6 bar at 20°C	90 psig at 68°F

* Other flange types, higher pressure ratings and materials available on request
 For extensive overview, see the dimensions, weights and pressure section of this datasheet

Materials

Measuring tube (exterior polyurethane coated)	DN 25 - 300 / 1" - 12"	SS 316 L (comparable to stainless steel 1.4404 and 1.4435)
	DN 350 - 3000 / 14" - 120"	carbon steel
External sensor cover	≤ DN 65 / 2 1/2"	SS 316 L
	≥ DN 80 / 3"	carbon steel
	≥ DN 350 / 14"	individual SS 316 L external transducer housing
Transducer/Transducer windows	SS 316 L	
Flanges (exterior polyurethane coated)	< DN 65 / 2.5"	SS 316 L
	> DN 80 / 3"	carbon steel
Connection box (exterior polyurethane coated)	Die-cast aluminium	

Patented transducer design



- Acoustic shielding
- Piezo crystal
- All metal transducer housing

UFM 3030 - Cross section
 Hermetically sealed 3-beam design

UFC 030 Ultrasonic Flow Converter

The converter has a backlit local display with three push buttons. All configuration data can either be entered by the push buttons or with the aid of a hand-held bar magnet and electromagnetic sensors, without opening the converter housing, or via the communication protocol (standard HART®). The compact converter (UFC 030 K) is mounted directly on the flow sensor, while the separate version (UFC 030 F) is supplied with a bracket for wall or pipe mounting.



Overall Functionality

Measurements available

- | | |
|----------|---|
| Standard | <ul style="list-style-type: none"> ● Continuous measurement of momentary volume flow rate and actual volume total ● Flow direction (forward or reverse) ● Velocity of Sound (VOS) ● Signal strength ● Self diagnostics ● Simple single stage batching |
| Optional | <ul style="list-style-type: none"> ● Corrected or standardized volume flow rate to API 2540 or customer specified ● Customer specified mass flow (requires customer data) |

Bidirectional measurement

Direction identified via status, pulse, or current outputs

Low flow cut-off

Cut-off active value 1-19% } programmable in increments of 1%
 Cut-off de-active value 2-20% }

Time constant

0.025 - 99 seconds (set in increments of 0.01; 0.1 and 1.0 seconds)

Galvanic isolation

All inputs and outputs are galvanically isolated from the power supply, but not from each other

Power supply

- | | |
|--------------------|---|
| mains supply | ● 100 – 240 V AC (48-63 Hz) +10% / -15% |
| low voltage supply | ● 24 V (AC or DC), AC: -10% / +15%, DC: 18 - 35 V |

Power consumption

- approx. 10 VA (AC) or approx. 10 W (DC)

Current output

Function

- | | |
|----------|--|
| Standard | <ul style="list-style-type: none"> ● Continuous measurement of actual volume flow rate ● Flow direction indication (forwards and reverse) ● Velocity of Sound (VOS) ● Transducer signal amplification ● Pressure or temperature indication based on analog input (1) or (2) |
| Optional | <ul style="list-style-type: none"> ● Corrected or standardized volume flow rate to API 2540 or customer specified ● Customer specified mass flow (requires customer data) |

Settings

for Q = 0%; 0 - 16 mA } programmable in increments of 1mA (Limit 20 - 22 mA)
 for Q = 100%; 4 - 20 mA }

Connection

Active mode: using internal power supply 24 V DC
 Current sink, load ≤ 680 ohm
 Passive mode: external voltage ≤ 18 ... 24 V DC, load ≤ 680 ohm

Pulse / Frequency / Status output

Function

Pulse output: pulse per volumetric unit (m³, barrels, liters, US gallons or user defined volume unit per hour, minute, second or user defined time unit)

- Standard ● Actual volume
- Optional ● Corrected or standardized volume to API 2540 or customer specified
- Optional ● Customer specified mass (requires customer specific density input)

Frequency output

- Standard ● Continuous measurement of actual volume flow rate
- Standard ● Velocity Of Sound (VOS)
- Standard ● Transducer signal gain (dB)
- Optional ● Pressure or temperature indication based on analog input (1) or (2)
- Optional ● Corrected or standardized volume flow rate to API 2540 or customer specified
- Optional ● Customer specified mass flow (requires customer specific density input)

Status output

- Diagnostics alarm path errors, totalizer overrun, all errors, analog input
- Flow direction indication (forwards and reverse)
- Batch volume reached
- Alarm trip point (high and low) based on actual volume flow rate

Settings

Pulse output Pulse/unit (max. 2000 Hz) (example 1000 pulses/barrel) pulse duty cycle 25, 50, 100, 200, or 500 ms for frequency < 10 Hz

Frequency output 0 to 2 000 Hz (example Q_{0%} - 0 Hz, Q_{100%} - 1000 Hz) at 100% of scale value, fmax - 2 kHz

Status output On or Off
 Voltage output = Uout Low: Uout < 5 V (off)
 High: Uout > 15 V (on)
 Max. Uout = 24 VDC

Connection

- Pulse, frequency and status output:
- Active mode connection to electronic counters using internal power supply 24 V DC / I ≤ 50 mA
 - Passive mode connection to electronic (EC) or electromechanical counters (EMC) external voltage, ≤ 19 - 32 VDC / I ≤ 150 mA

Analog input

Function

- Corrected volume version: two inputs to connect temperature and pressure signals for the corrected standard volume, according to API 2540, user defined volume or mass
- Measurement update 1 Hz

Setting

- Input 1 ● Unit: °Celsius or °Fahrenheit
- Input 1 ● Temperature for 4 mA, maximum temperature range -58°F to 302°F(-50°C to 150°C)
- Input 1 ● Temperature for 20 mA, maximum temperature range of -58°F to 302°F(-50°C to 150°C)
- Input 2 ● Unit: bar or psi
- Input 2 ● Pressure for 4 mA, maximum pressure range 0 to 1450 psi (0 to 100 bar)
- Input 2 ● Pressure for 20 mA, maximum pressure range 0 to 1450 psi (0 to 100 bar)

Connection

- Input 1 ● 4-20 mA for temperature sensor
- Input 1 ● Load 58 Ohm
- Input 1 ● Active (using UFC 030 24 V DC power) or passive
- Input 2 ● 4-20 mA for pressure
- Input 2 ● Load 58 Ohm
- Input 2 ● Active (using UFC 030 24 V DC power) or passive

Control input

Function

- Reset totalizer
- Acknowledge errors
- Force outputs to zero
- Initiate batch (see operating instructions for description of this function)

Setting

- On or Off

Connection

- Input voltage (Uin)
- Low: Uin < 5 V (off)
 - High: Uin > 15 V (on)
 - Max.: Uin-max = 32 V

Local display

3-field backlit LCD

1st line 8 character 7 segment numeral and sign display and symbols for key acknowledgement

2nd line 10 character, 14 segment text display

3rd line 5 markers to identify display in measuring mode

Function

- | | |
|----------|---|
| Standard | <ul style="list-style-type: none"> ● Actual volume flow rate in m³, barrels, liters, US gallons or user defined volume unit per hour, minute, second, or user defined time unit ● Actual volume total in m³, barrels, liters, US gallons or user defined volume unit (positive, negative, and sum totals), minimum 1 year overflow time ● Velocity of sound in m/s or ft/s ● Errors (flashing display and error code) ● Signal strength (in dB) |
| Optional | <ul style="list-style-type: none"> ● Corrected standard volume flow rate in m³, barrels, liters, US Gallons or user defined volume unit per hour, minute, second or user-defined time unit ● Calculated mass flow rate in user defined mass unit ● Corrected standard volume total in m³, barrels, liters, US Gallons or user defined corrected volume unit, minimum 1 year overflow time ● Calculated mass total in user defined unit, minimum 1 year overflow time ● Analog input in °C, °F, bar or psig |

Language

English, German or French

Housing

Die-cast aluminium (exterior polyurethane coated)

Signal cable

Only for separate versions, type MR06,

- | | |
|-----------|--|
| Standard: | O.D. = 0.43 inch (11 mm)
5 m (15 ft) |
| Optional: | 30 ft (10 m), 45 ft (15 m), 65 ft (20 m), 80 ft (25 m), 100 ft (30 m),
> 100 ft (> 30 m) on request |

Electrical connections



- | | |
|---------|--|
| 10 | Ground connection, not for protective earthing |
| L / 1L~ | Live power supply |
| N / 0L~ | Neutral power supply |



- | | |
|----|-----------------------------|
| PE | Protective earth connection |
| FE | Functional earth connection |

Standard connection

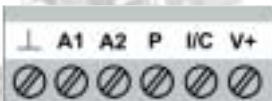

- | | |
|-----|--|
| ⊥ | Common ground |
| A1 | Analog input 1, for temperature measurement |
| A2 | Analog input 2, for pressure measurement |
| P | Pulse, frequency or status output |
| I/C | Combined Current output (I) and Digital/control input (C)
Current output (I) incl. HART communication |
| V+ | DC power supply from converter for active wiring of inputs and outputs |

Profibus connection

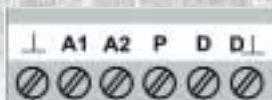

- | | |
|-------|---|
| D+ | Communication connection+ |
| D- | Communication connection - |
| P/I/C | Combined current output (I), digital/control (C) and pulse output (P). See individual I/C terminal and P terminal functions |

Dimensions and weights

**DIN as of
DN 350**

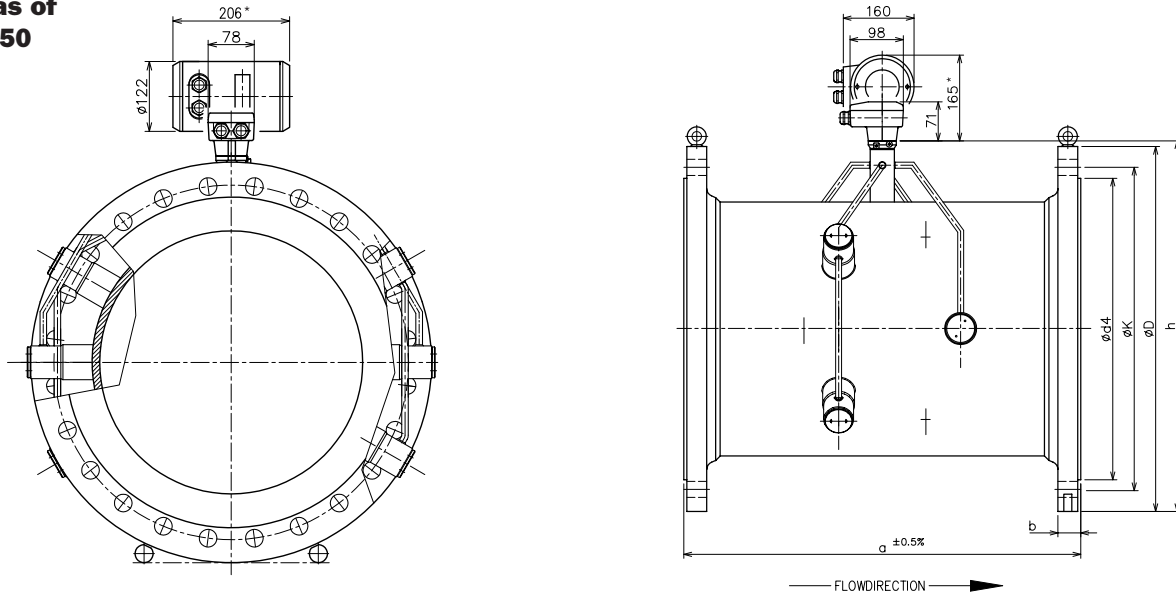

* Converter: add 30 mm width and 8 mm height for hazardous area versions.

Sensor DN	PN	sizes in mm (flange connection according to DIN 2632, 2633 and 2635)										
		a	Di	e	h	j	D	b	K	d4	i x d2	m (kg)
350	10	500	341.0	n.a.	540	n.a.	505	26	460	430	16 x 22	68
400	10	600	388.0	n.a.	595	n.a.	565	26	515	482	16 x 26	89
500	10	600	487.0	n.a.	697	n.a.	670	28	620	585	20 x 26	117

add 0.5 kg for F version
add 2.3 kg for K version

Design pressure

calculations are based on using spiral wound gaskets

Sensor DN	Standard material		PN	Design Pressure (bar)					
				Separate version (F)				Compact version (K)	
	Tube	Flange		20°C	140°C	180°C	220°C	20°C	140°C
350	Carbon Steel	Carbon Steel	10	10	10	9.9	n.a.	10	10
400	Carbon Steel	Carbon Steel	10	10	10	10	n.a.	10	10
500	Carbon Steel	Carbon Steel	10	10	10	9.8	n.a.	10	10

* With carbon steel DIN flanges please note that minimum temperature is limited to -10°C. For temperatures down to -25°C other materials are available on request.

Dimensions and weights

ANSI 150 lbs up to 12"

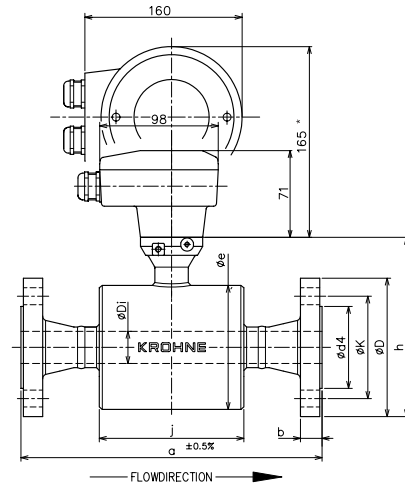
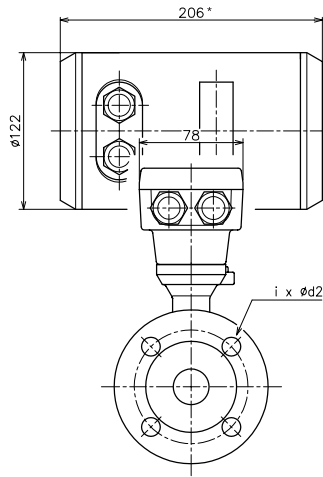

* Converter: add 30 mm width and 8 mm height for hazardous area versions.

Sensor		sizes in mm and inch (according to ANSI B 16.5)																					
ANSI		a		Di		e		h		j		D		b		K		d4		i x d2		weight	
inch	lbs	inch	mm	inch	mm	inch	mm	inch	mm	inch	mm	inch	mm	inch	mm	inch	mm	inch	mm	inch	mm	lbs	kg
1	150	9.84	250	1.05	26.7	4.17	106	5.7	146	4.72	120	4.25	108.0	0.56	14.2	3.12	79.2	2.00	50.8	4 x 0.62	4 x 15.7	13.2	6
1-1/4"	150	10.24	260	1.38	35.1	4.17	106	6.0	152	4.72	120	4.62	117.3	0.62	15.7	3.50	88.9	2.50	63.5	4 x 0.62	4 x 15.7	15.4	7
1-1/2"	150	10.63	270	1.61	40.9	4.17	106	6.2	157	4.72	120	5.00	127.0	0.69	17.5	3.88	98.6	2.88	73.2	4 x 0.62	4 x 15.7	17.6	8
2	150	11.81	300	2.07	52.5	5.24	133	7.2	183	5.98	152	6.00	152.4	0.75	19.1	4.75	120.7	3.62	91.9	4 x 0.75	4 x 19.1	26.5	12
2-1/2"	150	13.78	350	2.47	62.7	5.24	133	7.7	196	5.98	152	7.00	177.8	0.88	22.4	5.50	139.7	4.12	104.6	4 x 0.75	4 x 19.1	35.3	16
3	150	13.78	350	3.07	77.9	7.48	190	9.2	234	6.69	170	7.50	190.5	0.94	23.9	6.00	152.4	5.00	127.0	8 x 0.75	4 x 19.1	37.5	17
4	150	13.78	350	4.03	102.3	8.46	215	10.5	266	7.48	190	9.00	228.6	0.94	23.9	7.50	190.5	6.19	157.2	8 x 0.75	8 x 19.1	50.7	23
5	150	13.78	350	5.05	128.2	9.33	237	11.4	290	8.27	210	10.00	254.0	0.94	23.9	8.50	215.9	7.31	185.7	8 x 0.88	8 x 22.4	59.5	27
6	150	15.75	400	6.07	154.1	10.47	266	12.5	317	9.29	236	11.00	279.4	1.00	25.4	9.50	241.3	8.50	215.9	8 x 0.88	8 x 22.4	77.2	35
8	150	15.75	400	7.98	202.7	14.13	359	15.6	395	8.86	225	13.50	342.9	1.13	28.6	11.75	298.4	10.63	269.9	8 x 0.88	8 x 22.2	145.5	66
10	150	19.69	500	10.04	255.0	16.02	407	17.8	451	10.24	260	16.00	406.4	1.19	30.2	14.25	361.9	12.75	323.8	12 x 1.00	12 x 25.4	163.1	74
12	150	19.69	500	12.01	305.0	17.99	457	20.2	514	11.42	290	19.00	482.6	1.25	31.8	17.00	431.8	15.00	381.0	12 x 1.00	12 x 25.4	229.3	104

add 1.1 lbs (0.5 kg) for F version
add 5.1 lbs (2.3 kg) for K version

Design pressure

calculations are based on using spiral wound gaskets

Sensor inch	Standard material		ANSI	Design Pressure (bar and psi)													
	Tube	Flange		Separate version (F)								Compact version (K)					
				70° F	20°C	285°F	140°C	355°F	180°C	430°F	220°C	70°F	20°C	285°F	140°C		
1	SS 316 L	SS 316 L	150	231	15.9	178	12.3	167	11.5	155	10.7	231	15.9	178	12.3		
1-1/4"	SS 316 L	SS 316 L	150	231	15.9	178	12.3	167	11.5	155	10.7	231	15.9	178	12.3		
1-1/2"	SS 316 L	SS 316 L	150	231	15.9	178	12.3	167	11.5	155	10.7	231	15.9	178	12.3		
2	SS 316 L	SS 316 L	150	231	15.9	178	12.3	167	11.5	155	10.7	231	15.9	178	12.3		
2-1/2"	SS 316 L	SS 316 L	150	231	15.9	178	12.3	167	11.5	155	10.7	231	15.9	178	12.3		
3	SS 316 L	Carbon Steel	150	286	19.7	235	16.2	213	14.7	191	13.2	286	19.7	235	16.2		
4	SS 316 L	Carbon Steel	150	286	19.7	235	16.2	213	14.7	191	13.2	286	19.7	235	16.2		
5	SS 316 L	Carbon Steel	150	286	19.7	235	16.2	213	14.7	191	13.2	286	19.7	235	16.2		
6	SS 316 L	Carbon Steel	150	286	19.7	235	16.2	213	14.7	191	13.2	286	19.7	235	16.2		
8	SS 316 L	Carbon Steel	150	286	19.7	235	16.2	213	14.7	n.a.	n.a.	286	19.7	235	16.2		
10	SS 316 L	Carbon Steel	150	286	19.7	235	16.2	213	14.7	n.a.	n.a.	286	19.7	235	16.2		
12	SS 316 L	Carbon Steel	150	286	19.7	235	16.2	213	14.7	n.a.	n.a.	286	19.7	235	16.2		

**ANSI 150 lbs
as of 14"**

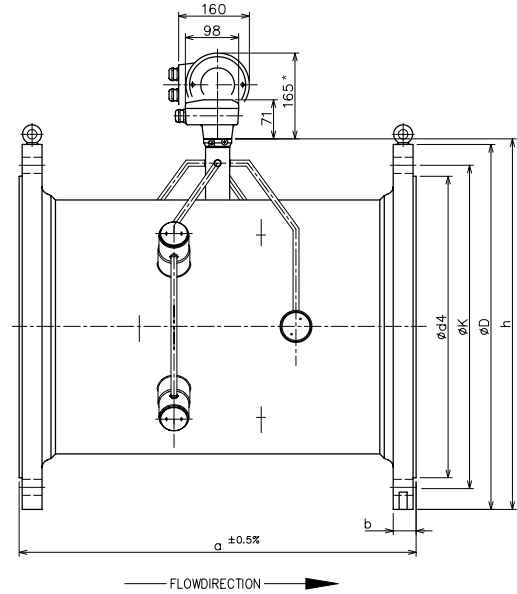
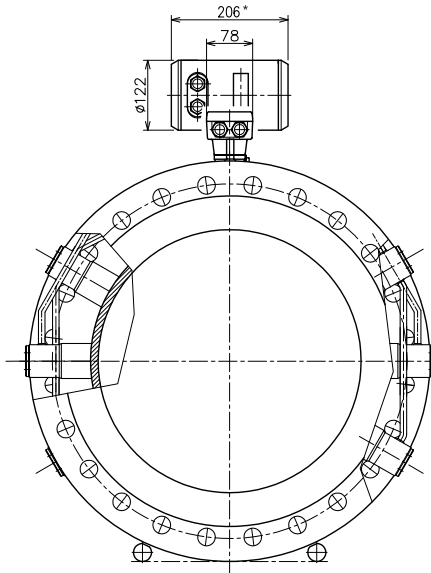

* Converter: add 30 mm width and 8 mm height for hazardous area versions.

		sizes in mm and inch (according to ANSI B 16.5)																					
Sensor inch	ANSI lbs	a		Di		e		h		j		D		b		K		d4		i x d2		weight	
		inch	mm	inch	mm	inch	mm	inch	mm	inch	mm	inch	mm	inch	mm	inch	mm	inch	mm	inch	mm	lbs	kg
14	150	27.56	700	13.27	337.0	n.a.	n.a.	21.8	554	n.a.	n.a.	21.00	533.4	1.37	34.9	18.75	476.2	16.25	412.7	16 x 1.12	12 x 28.6	262.4	119
16	150	31.50	800	15.28	388.0	n.a.	n.a.	24.1	612	n.a.	n.a.	23.50	596.9	1.44	36.5	21.25	539.7	18.50	469.9	16 x 1.12	16 x 28.6	348.3	158
18	150	31.50	800	17.24	438.0	n.a.	n.a.	25.8	656	n.a.	n.a.	25.00	635.0	1.56	39.7	22.75	577.8	21.00	533.4	16 x 1.25	16 x 31.7	385.8	175
20	150	31.50	800	19.25	489.0	n.a.	n.a.	28.1	713	n.a.	n.a.	27.50	698.5	1.69	42.9	25.00	635.0	23.00	584.2	20 x 1.25	20 x 31.7	463.0	210

add 1.1 lbs (0.5 kg) for F version
add 5.1 lbs (2.3 kg) for K version

Design pressure
calculations are based on using spiral wound gaskets

			Design Pressure (bar and psi)												
			Separate version (F)									Compact version (K)			
Sensor inch	Standard material		ANSI lbs	70°F	20°C	285°F	140°C	355°F	180°C	430°F	220°C	70°F	20°C	285°F	140°C
	Tube	Flange		psi	bar	psi	bar	psi	bar	psi	bar	psi	bar	psi	bar
14	Carbon Steel	Carbon Steel*	150	286	19.7	235	16.2	213	14.7	n.a.	n.a.	286	19.7	235	16.2
16	Carbon Steel	Carbon Steel*	150	286	19.7	235	16.2	213	14.7	n.a.	n.a.	286	19.7	235	16.2
18	Carbon Steel	Carbon Steel*	150	286	19.7	235	16.2	213	14.7	n.a.	n.a.	286	19.7	235	16.2
20	Carbon Steel	Carbon Steel*	150	286	19.7	235	16.2	213	14.7	n.a.	n.a.	286	19.7	235	16.2

* With carbon steel ANSI flanges please note that minimum temperature is limited to -4°F (-20°C). For temperatures down to -13°F (-25°C) other materials are available on request.

Dimensions and weights

ANSI 300 lbs up to 6"

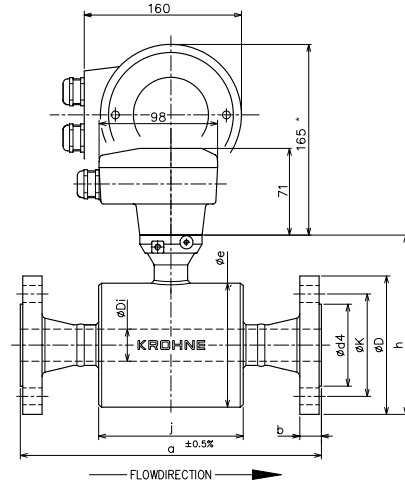
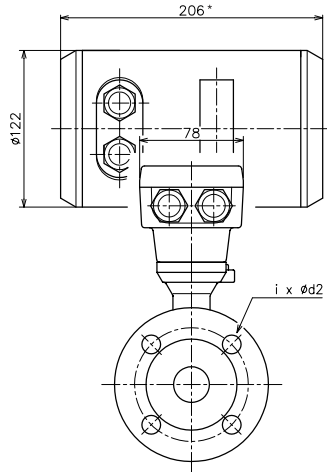

* Converter: add 30 mm width and 8 mm height for hazardous area versions.

		sizes in mm and inch (according to ANSI B 16.5)																					
Sensor	ANSI	a		Di		e		h		j		D		b		K		d4		i x d2		weight	
inch	lbs	inch	mm	inch	mm	inch	mm	inch	mm	inch	mm	inch	mm	inch	mm	inch	mm	inch	mm	inch	mm	lbs	kg
1	300	9.84	250	1.05	26.7	4.17	106	6.1	155	4.72	120	4.88	123.9	0.69	17.5	3.50	88.9	2.00	50.8	4 x 0.75	4 x 19.0	15.4	7
1-1/4"	300	10.24	260	1.38	35.1	4.17	106	6.3	160	4.72	120	5.25	133.3	0.75	19.0	3.88	98.5	2.50	63.5	4 x 0.75	4 x 19.0	17.6	8
1-1/2"	300	10.63	270	1.61	40.9	4.17	106	6.7	170	4.72	120	6.12	155.4	0.81	20.6	4.50	114.3	2.88	73.1	4 x 0.88	4 x 22.3	22.0	10
2	300	11.81	300	2.07	52.5	5.24	133	7.4	189	5.98	152	6.50	165.1	0.88	22.3	5.00	127.0	3.62	91.9	8 x 0.75	8 x 19.0	30.9	14
2-1/2"	300	13.78	350	2.47	62.7	5.24	133	8.0	202	5.98	152	7.50	190.5	1.00	25.4	5.88	149.3	4.12	104.6	8 x 0.88	8 x 22.3	39.7	18
3	300	13.78	350	3.07	77.9	7.48	190	9.6	244	6.69	170	8.25	209.5	1.12	28.4	6.62	168.1	5.00	127.0	8 x 0.88	8 x 22.3	46.3	21
4	300	15.75	400	4.03	102.3	8.46	215	11.0	279	7.48	190	10.00	254.0	1.25	31.7	7.88	200.1	6.19	157.2	8 x 0.88	8 x 22.3	70.5	32
5	300	15.75	400	5.05	128.2	9.33	237	11.9	303	8.27	210	11.00	279.4	1.38	35.0	9.25	234.9	7.31	185.6	8 x 0.88	8 x 22.3	90.4	41
6	300	17.72	450	6.07	154.1	10.47	266	13.2	336	9.29	236	12.50	317.5	1.44	36.5	10.62	269.7	8.50	215.9	12 x 0.88	12 x 22.3	116.8	53

add 1.1 lbs (0.5 kg) for F version
add 5.1 lbs (2.3 kg) for K version

Design pressure

calculations are based on using spiral wound gaskets

			Design Pressure (bar and psi)													
			Separate version (F)											Compact version (K)		
Sensor	Standard material		ANSI	70°F	20°C	285°F	140°C	355°F	180°C	430°F	220°C	70°F	20°C	285°F	140°C	
	Tube	Flange		lbs	psi	bar	psi	bar	psi	bar	psi	bar	psi	bar	psi	bar
1	SS 316 L	SS 316 L	300	600	41.4	463	31.9	432	29.8	405	27.9	600	41.4	463	31.9	
1-1/4"	SS 316 L	SS 316 L	300	600	41.4	463	31.9	432	29.8	405	27.9	600	41.4	463	31.9	
1-1/2"	SS 316 L	SS 316 L	300	600	41.4	463	31.9	432	29.8	405	27.9	600	41.4	463	31.9	
2	SS 316 L	SS 316 L	300	600	41.4	463	31.9	432	29.8	405	27.9	600	41.4	463	31.9	
2-1/2"	SS 316 L	SS 316 L	300	600	41.4	463	31.9	432	29.8	405	27.9	600	41.4	463	31.9	
3	SS 316 L	Carbon Steel	300	740	51	658	45.4	644	44.4	625	43.1	740	51	658	45.4	
4	SS 316 L	Carbon Steel	300	740	51	658	45.4	644	44.4	625	43.1	740	51	658	45.4	
5	SS 316 L	Carbon Steel	300	740	51	658	45.4	644	44.4	625	43.1	740	51	658	45.4	
6	SS 316 L	Carbon Steel	300	740	51	658	45.4	644	44.4	625	43.1	740	51	658	45.4	

Sizing

Choosing the correct size meter is very simple due to the extremely wide range of possible velocities, from 1.5 ft/sec (0.5 m/s) all the way up to 66 ft/sec (20 m/s).

Below 1.5 ft/sec (0.5 m/s) the stated accuracy begins to degrade, but measurement is still possible, all the way down to zero flow.

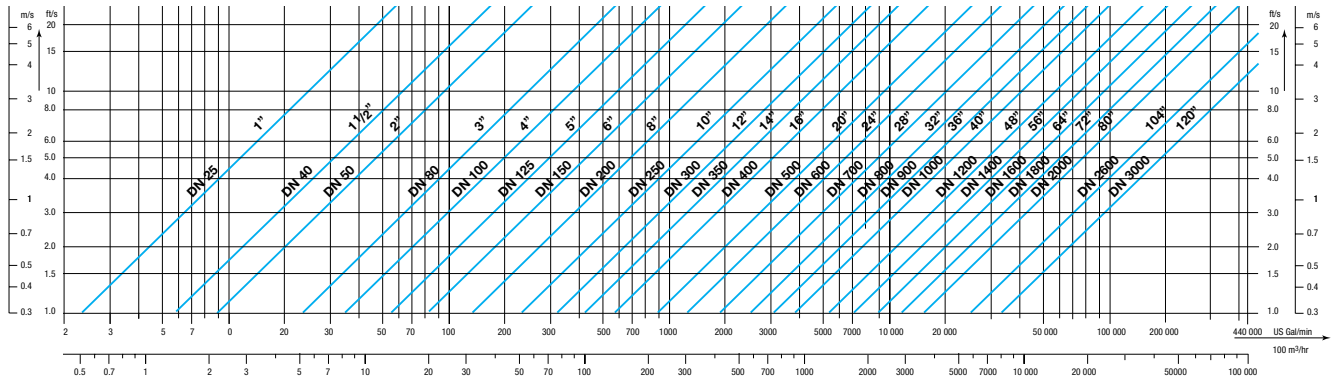

Standard installation instructions

- **Completely filled flow sensor**

Install the UFS 3000 ultrasonic flow sensor at a location where it will be completely filled under all circumstances, including zero flow velocity.

- **Flow conditioning**

To maintain flow measurement within the stated accuracy under all circumstances, it is required to install 10D of straight pipe run before and 5D after the flow sensor. D = diameter of the flow sensor.

Deviation from these up and down stream runs may affect the accuracy of the flow meter, not its functioning or its repeatability.

- **Horizontal Pipelines**

Make sure the ultrasonic flow sensor is installed so the acoustic beams are in a horizontal plane:

In long horizontal pipe runs, where the collection of 'air pockets' in the ultrasonic flow sensor are expected, installation of the meter in a slightly ascending section is advised.

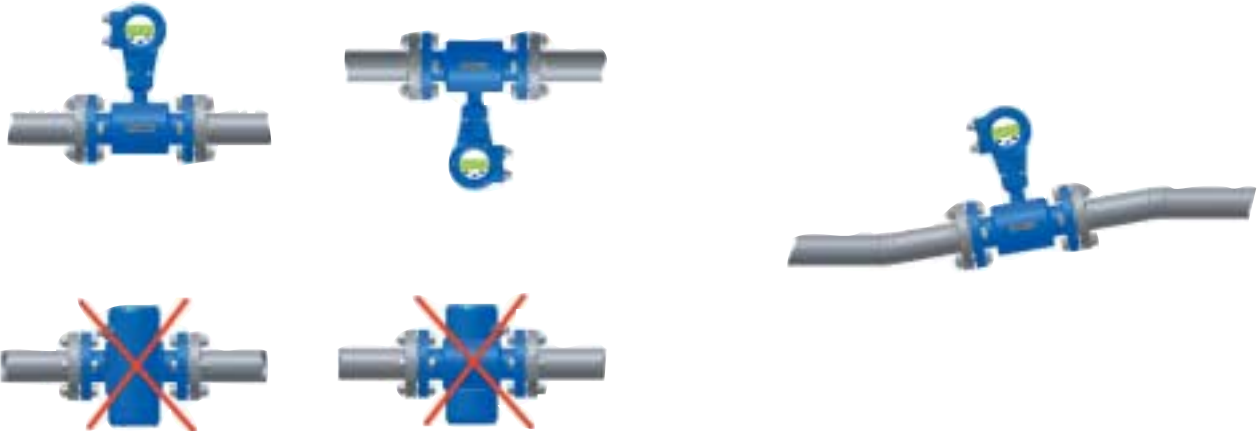

● **Pumps and control valves**

Always install the UFM 3030 downstream of pumps.
 Always install the UFM 3030 upstream of control valves, to avoid cavitations and flow disturbances caused by the modulation of the valve.



● **Zero checking**

Zero setting is not required with ultrasonic flow meters.
 For zero checking it is advised to install shutoff valves before or after the flow sensor.

● **Mixing points**

Install the UFM 3030 upstream of chemical addition mixing points or at a sufficient distance downstream to allow homogeneous mixing, minimum 30D (D = nominal pipe diameter), otherwise measurements may be unsteady.
 Consult KROHNE for advice on applications exceeding these general recommendations.

Connection diagram examples

Current output

Active

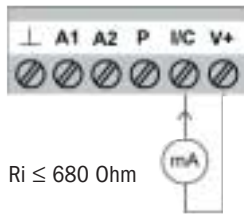

Passive

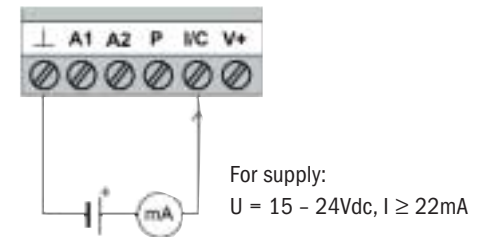

Pulse output

Active

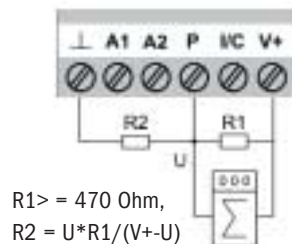
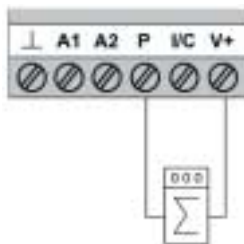

Passive

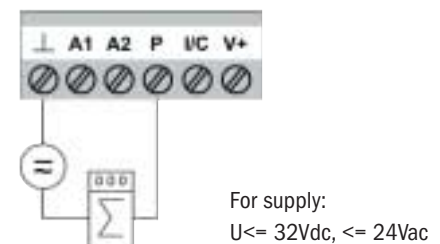

Digital input

Active

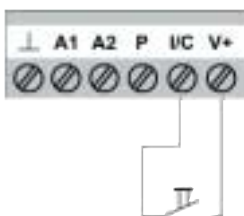

Passive

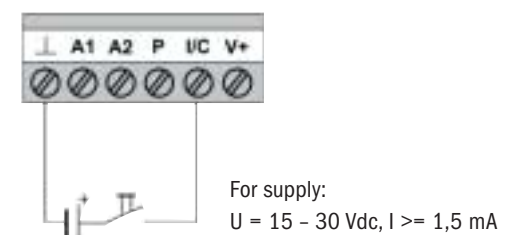

Analog input

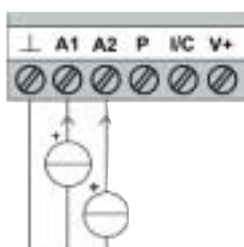

Ordering Code UFS Flow Sensor DN 25 ... 65

Code nominal diameter										
VN51	4	4	UFS 3000	DN 25	/	1"				
		5	UFS 3000	DN 32	/	1 1/4"				
		6	UFS 3000	DN 40	/	1 1/2"				
		7	UFS 3000	DN 50	/	2"				
		8	UFS 3000	DN 65	/	2 1/2"				
nominal pressure										
		5	DIN 2501 PN 40	Form C		stainless steel 316L				
		6	DIN 2501 PN 64	Form C		stainless steel 316L				
		7	DIN 2501 PN 100	Form C		stainless steel 316L				
		A	ANSI 150 lb RF (full rating)			stainless steel 316L				
		B	ANSI 300 lb RF (full rating)			stainless steel 316L				
		D	ANSI 600 lb RF (full rating)			stainless steel 316L				
		E	ANSI 900 lb RF (full rating)			stainless steel 316L				
		M	JIS 20K			stainless steel 316L			DN 25 - 40	
		N	JIS 10K			stainless steel 316L			DN 50 - 65	
		W	ANSI 600 lb RTJ (full rating)			stainless steel 316L				
		X	ANSI 900 lb RTJ (full rating)			stainless steel 316L				
design / protect. class										
		1	compact with UFC 030 K / IP 67	140 °C / 282 F						
		2	separate with UFC 030 F / IP 67	180 °C / 356 F						
		3	separate with UFC 030 F / IP 68	180 °C / 256 F						
		4	separate with UFC 030 F / IP 67	220 °C / 428 F						
		5	separate with UFC 030 F / IP 68	220 °C / 428 F						
Ex approval										
		0	without							
		1	ATEX (former EEx Zone 1)							
		2	Ex nA Zone 2							
		3	FM Div. 1	(USA)						
		4	FM Div. 2	(USA)						
		6	CSA DIV 1							
		7	CSA Zone 1							
		A	TIIS	(Japan)						
cable connection										
		1	at converter			(compact version)				
		3	2 x 1/2" NPT			(separate version)				
		4	2 x PF 1/2"			(separate version)				
		5	2 x M20 x 1,5			(separate version)				
tube / flange material										
		2*	SS316 L / SS 316 L							
cable										
		0*	standard (compact none, separate 5 m)							
		1	10 m			(separate version)				
		2	15 m			(separate version)				
		3	20 m			(separate version)				
		4	25 m			(separate version)				
		5	30 m			(separate version)				
calibration										
		0*	standard							
		2	special incl. NKO							
finish										
		1*	blue (RAL 5015)							
		2	silver (blasted)							
sensors										
		0*	standard							
Higher pressure rating / other flange materials on request										
* Standard										
VN51	4						2		0	0
Complete ordering code										
000										

Ordering Code UFS 3000 Flow Sensor DN 80 ... 300

Code nominal diameter										
VN52	4	A	UFS 3000	DN 80	/	3"				
		B	UFS 3000	DN 100	/	4"				
		C	UFS 3000	DN 125	/	5"				
		D	UFS 3000	DN 150	/	6"				
		E	UFS 3000	DN 200	/	8"				
		F	UFS 3000	DN 250	/	10"				
		G	UFS 3000	DN 300	/	12"				
nominal pressure										
		2	PN 10			DN 200 - 300				
		3	PN 16			DN 100 - 150				
		4	PN 25			DN 100 - 300				
		5	PN 40			DN 80				
		6	PN 64			DN 80 - 300				
		A	ANSI 150 lb RF (full rating)			DN 3" - 6"; DN 8" - 12" see internal option pricelist				
		B	ANSI 300 lb RF (full rating)							
		N	JIS 10 K							
design / protect. class										
		1	compact with UFC 030 K / IP 67	140 °C / 282 F						
		2	separate with UFC 030 F / IP 67	180 °C / 356 F						
		3	separate with UFC 030 F / IP 68	180 °C / 256 F						
		4	separate with UFC 030 F / IP 67	220 °C / 428 F		(DN 80 - 150 / 3" - 6")				
		5	separate with UFC 030 F / IP 68	220 °C / 428 F		(DN 80 - 150 / 3" - 6")				
Ex approval										
		0	without							
		1	ATEX (former EEx Zone 1)							
		2	Ex nA Zone 2							
		3	FM Div.1	(USA)						
		4	FM Div.2	(USA)						
		6	CSA DIV 1							
		7	CSA Zone 1							
		A	TIIS	(Japan)						
cable connection										
		1	at converter			(compact version)				
		3	2 x 1/2" NPT			(separate version)				
		4	2 x PF 1/2"			(separate version)				
		5	2 x M20 x 1,5			(separate version)				
tube / flange material										
		1*	SS316 L / steel	slip on version		Standard for DIN / JIS; ANSI on request				
		2	SS316 L / SS 316 L	slip on version						
		A	SS316 L / steel	butt weld version		Standard for ANSI; DIN / JIS on request				
		B	SS316 L / SS 316 L	butt weld version						
cable										
		0*	standard (compact none, separate 5 m)							
		1	10 m			(separate version)				
		2	15 m			(separate version)				
		3	20 m			(separate version)				
		4	25 m			(separate version)				
		5	30 m			(separate version)				
calibration										
		0*	standard							
		2	special incl. NKO							
finish										
		1*	blue (RAL 5015)							
		2	silver (blasted, option DN 80-150 / 3"-6")							
sensors										
		0*	standard							
Higher pressure rating / other flange materials on request										
* Standard										
VN52	4						0	0		000
										Complete ordering code

Ordering Code UFS 3000 Flow Sensor DN 350 ... 2000

Code nominal diameter										
VN53	4	H	UFS 3000	DN 350	/	14"				
		K	UFS 3000	DN 400	/	16"				
		L	UFS 3000	DN 450	/	18"				
		M	UFS 3000	DN 500	/	20"				
		N	UFS 3000	DN 600	/	24"				
		P	UFS 3000	DN 700	/	28"				
		R	UFS 3000	DN 800	/	32"				
		S	UFS 3000	DN 900	/	36"				
		T	UFS 3000	DN 1000	/	40"				
		U	UFS 3000	DN 1200	/	48"				
		V	UFS 3000	DN 1400	/	56"				
		W	UFS 3000	DN 1600	/	64"				
		X	UFS 3000	DN 1800	/	72"				
		Y	UFS 3000	DN 2000	/	80"				
nominal pressure										
		1	PN 6			DN 1200 - 2000				
		2	PN 10			DN 350 - 1000				
		3	PN 16			DN 350 - 2000				
		4	PN 25			DN 350 - 2000				
		5	PN 40			DN 350 - 2000				
		6	PN 64			DN 350 - 2000				
		A	ANSI 150 lb RF (full rating)			DN 14" - 80"				
		B	ANSI 300 lb RF (full rating)			DN 14" - 80"				
		N	JIS 10 K							
		W	AWWA Class B							
design / protect. class										
		1	compact with UFC 030 K / IP 67	140 °C / 282 F						
		2	separate with UFC 030 F / IP 67	180 °C / 356 F						
		3	separate with UFC 030 F / IP 68	180 °C / 356 F						
Ex approval										
		0	without							
		1	ATEX (former EEx Zone 1)							
		2	Ex nA Zone 2							
		3	FM Div.1	(USA)						
		4	FM Div.2	(USA)						
		6	CSA DIV 1							
		7	CSA Zone 1							
		A	TIIS	(Japan)						
cable connection										
		1	at converter			(compact version)				
		3	2 x 1/2" NPT			(separate version)				
		4	2 x PF 1/2"			(separate version)				
		5	2 x M20 x 1,5			(separate version)				
tube / flange material										
		3*	steel / steel	slip on version		Standard for DIN / JIS; ANSI on request				
		5	SS 304 / SS 304 L	slip on version						
		C	steel / steel	butt weld version		Standard for ANSI; DIN / JIS on request				
		E	SS 304 / SS 304 L	butt weld version						
cable										
		0*	standard (compact none, separate 5 m)							
		1	10 m			(separate version)				
		2	15 m			(separate version)				
		3	20 m			(separate version)				
		4	25 m			(separate version)				
		5	30 m			(separate version)				
calibration										
		0*	standard							
		2	special incl. NKO							
Higher pressure rating / other flange materials on request										
* Standard										
VN53	4							0000000	Complete ordering code	

Ordering Code UFC 030 Flow Converter

Code		Signal converter	
VN50	4	1	UFC 030 K Batch compact version
		2	UFC 030 K Batch MP compact version MP-version standard for Ex-version
		4	UFC 030 F Batch field version
		5	UFC 030 F Batch MP field version MP-version standard for Ex-version
		7	UFC 030 K i MP compact version MP-version standard for Ex-version
		8	UFC 030 F i MP field version MP-version standard for Ex-version
		A	UFC 030 K Temperature + Pressure compact version
		B	UFC 030 K Temperature + Pressure MP compact version MP-version standard for Ex-version
		D	UFC 030 F Temperature + Pressure field version
		E	UFC 030 F Temperature + Pressure MP field version MP-version standard for Ex-version
power supply			
	4	24	V AC / DC
	D	100 - 240	V AC
Ex-approval			
	0	without	
	1	ATEX	
	2	Ex nA Zone 2	
	3	A Ex FM DIV 1	(USA)
	4	A Ex FM DIV 2	(USA)
	6	CSA DIV 1	
	7	CSA Zone 1	
	A	TIIS (Japan)	
Ex-i output			
	0	without	
	1	Ex-i 1 mA passive + HART + Binary pas.	
	2	Ex-i 2 mA passive + Profibus / HART	
	B	i 2 mA passive + Profibus / HART (non-ATEX)	
instr.manual / language			
	1	german / german	
	2	english GB / english	
	3	english US / english	
	4	french / french	
cable connection			
	2	2 x 1/2" NPT	
	3	2 x PF 1/2	
	4*	2 x M20 x 1,5	
converter housing			
	1*	Die-cast aluminum	
	2	SS 1.4404	

VN50	4									00000	Complete ordering code
------	---	--	--	--	--	--	--	--	--	-------	------------------------

* Standard

KROHNE offers you complete capability



UFM 3030 is the latest in a line of innovative level and flow products designed and manufactured by KROHNE for process industries worldwide.

With manufacturing facilities and sales offices strategically located in all major industrial markets,



KROHNE is ideally placed to provide both front line and after sales service and support for end-users and contractors alike.

KROHNE is one of the very few manufacturers who can offer a comprehensive range of level and



flow products ensuring that the right solution is available for each application.



The KROHNE range includes the following products and technologies:

- Flowmeters: Electromagnetic, Ultrasonic, Vortex, Variable Area
- Mass Meters: Density/concentration Coriolis
- Flow Switches: Moving Vane and Electromagnetic
- Level Gauges: Radar (Microwave & TDR) & Float
- Level Switches: Capacitance and Vibrating Probe
- Communications: HART®, FF, PROFIBUS, MODBUS, PDM and AMS

For more information, contact your local representative or visit www.KROHNE.com

North America

KROHNE Inc.
7 Dearborn Road
Peabody, MA 01960
Tel: +1-978 535 - 60 60
Fax: +1-978 535 - 17 20
E-mail: krohne@krohne.com

International

KROHNE Messtechnik
GmbH & Co. KG
Ludwig-Krohne-Str.
D-47058 Duisburg
Tel: +49(0)203-301-0
Fax: +49(0)203-301 389
E-mail: info@krohne.de