



## OPTIWAVE 5200 C Supplementary instructions

2-wire / 10 GHz Radar (FMCW) Level Meter

### **Description of PROFIBUS PA interface**

The documentation is only complete when it is used in combination with the relevant documentation of the level meter.



1	Safety instructions	3
<hr/>		
1.1	Installation .....	3
1.2	Scope of the document .....	3
1.3	Scope of delivery .....	3
2	PROFIBUS PA	4
<hr/>		
2.1	Software history .....	4
2.2	Device description .....	4
2.3	Function blocks and the PROFIBUS PA Profile .....	4
2.4	Technical data .....	5
3	Electrical connection	6
<hr/>		
3.1	Topology of a PROFIBUS PA network .....	6
3.2	Electrical connection for signal converter .....	7
4	Commissioning / Operation	8
<hr/>		
4.1	Hardware settings .....	8
4.2	GSD files .....	10
4.3	Ident. Number .....	10
4.4	Configuration of cyclic data transfer .....	11
4.5	Cyclic data .....	12
4.5.1	Input data .....	12
4.6	Diagnosis .....	17
5	Notes	21
<hr/>		

## 1.1 Installation

Install the GSD files in your system. If it is necessary to use the process control system to change the settings of the device, install the DD files. If it is necessary to use PACTware™ to change the settings of the device, install PACTware™ and the DTM PROFIBUS PA files.

The software, files and installation instructions are given on the DVD-ROM supplied with the device. You can download the latest version of PACTware™ and the DTM PROFIBUS PA from our website. For more data, refer to the “readme.txt” files.

## 1.2 Scope of the document

These instructions are supplementary to the standard product documentation of the signal converter. The details described herein, in particular the safety information, are valid and shall be adhered to. The present supplementary instructions provide additional information for the device when it is connected to a PROFIBUS network.



### **INFORMATION!**

*The information in this document only contains the data applicable to the PROFIBUS module. The technical data in the signal converter Handbook is valid in its current version, provided that it is not rendered invalid or replaced by these supplementary instructions.*

## 1.3 Scope of delivery

A device for PROFIBUS communication is supplied with:  
Supplementary instructions for the PROFIBUS PA interface (this document)

## 2.1 Software history

Issued	Signal converter		Application program		System integration		
Mth./year	Hardware	Firmware	Hardware	Software	Driver	Version	Model name
08/13	PROFIBUS PA module Ident. No. 0x4550 (4001858601c)	V2.42.0.42	Simatic PCS7 or other SPS of other manufact.	HW Config	GSD (device specific)	KR014554.GSD	OPTIWAVE 5200
				or other Software of other SPS manufact.	GSD (profile specific)	PA1397.GSD	AI 1 (Phy MBP)
			Laptop / PC	PDM (≥ 6.0 SP5)	DD (Ident.-No.)		
				Pactware	DTM ≥	1.0.0	

## 2.2 Device description

This device is a 2-wire level transmitter that uses FMCW (Frequency Modulated Continuous Wave) / Radar technology. Radar is a non-contact technology. It measures the distance, level, mass, volume, flow rate and reflection of liquids, pastes and slurries. It is particularly suitable for the level measurement of corrosive and viscous products.

The level transmitter has an MBP (Manchester-coded, bus-powered) interface to connect the device to a PROFIBUS PA network, when equipped with the appropriate options.

The level transmitter is approved for use in potentially explosive atmospheres when equipped with the appropriate options.

## 2.3 Function blocks and the PROFIBUS PA Profile

The Analog Input Function Block agrees with PROFIBUS PA Profile 3.02. The Analog Input Function Block is the data interface to a process control system (a PLC, ...). The control system (cyclic communication services) can read or write input and output data.



### **INFORMATION!**

*The PROFIBUS PA Profile 3.02 has a standard set of parameters and functions available for PROFIBUS devices used in process control. The PROFIBUS device is a function block application in which parameters and functions are grouped into different blocks.*

The device has these blocks:

Block	Usage
1 Physical Block (PB)	contains identification and diagnosis parameters of the device
1 Level Transducer Block (TB-Level)	contains parameters and functions to control the level measurement
4 Analog Input Function Blocks (AI-FB)	contains parameters and functions to control the measuring output; provides the measuring value(s)

The device has 4 slots. The Analog Input Function Blocks use slot 1 (as a virtual module). The user cannot change this setting. But the user can change the measurement name and unit for each Function Block. Refer to the table that follows:



**INFORMATION!**

*If it is necessary to change the measurement name, change the channel parameter in the acyclic PROFIBUS services.*

Slot	Module type	Measurement name	Unit
1	AI-FB	Level (default setting)	mm ①
		Distance	mm ①
		Conversion	L ①
		Conversion Distance	L ①

① Default measurement unit

The calibration units are used as default units.

## 2.4 Technical data

### Hardware

Type	PROFIBUS MBP interface. This interface agrees with IEC 61158-2 (bit rate 31.25 kbit/s); voltage mode (MBP = Manchester-Coded, Bus-Powered)
Device power supply	9...32 V - bus powered; no additional power supply required
Polarity sensitivity	No
Base current	14 mA
FDE	Yes. The Fault Disconnection Electronics (FDE) operates independently.
Max. error current	20.5 mA
Start current after 10 ms	Lower than base current

### Software

Supported GSD	KR014554.GSD PA139700.GSD	
Device profile	PROFIBUS PA Profile V3.02; conformance class B, compact	
Address setting	Default:	126
	Hardware DIP switch:	0...125
	PROFIBUS service Set_Slave_Add:	0...125
	Factory_Reset=2712:	126
Write protection	Password and/or hardware switch	
SAPs	2 × MS1 SAPs – acyclic interface to PLC	
	3 × MS2 SAPs – the number of MS2 Service Access Points is usually equal to the maximum number of master class 2 tools	
Function blocks	1 Physical Block 1 Level Transducer Block 4 Analog Input Function Blocks	

### 3.1 Topology of a PROFIBUS PA network

The following diagram shows a typical network configuration with PROFIBUS PA devices in hazardous and non-hazardous areas, as well as the connection of conventional non-PROFIBUS devices (e.g. with 4 ... 20 mA signals) to a PROFIBUS network.

The PROFIBUS PA segment is connected to a segment coupler which, among other things, provides the conversion to the PROFIBUS DP bus line. In addition it provides the power supply for bus-powered PROFIBUS PA devices. Refer to the instruction manual of the segment coupler concerning the DP bus parameters, e.g. the supported baud rates.

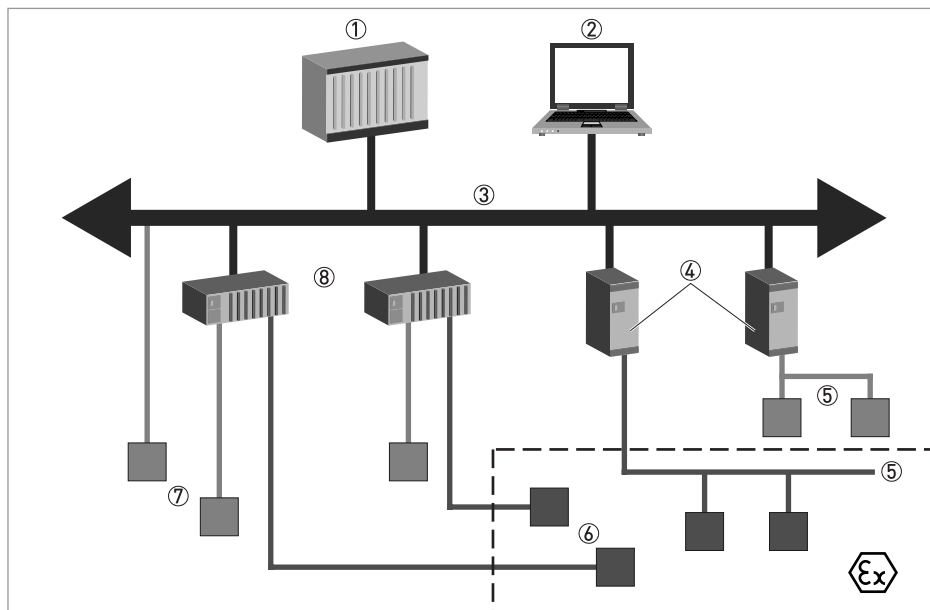

Figure 3-1: PROFIBUS PA network

- ① Control system (PLC); class 1 master
- ② Engineering or operation control tool; class 2 master
- ③ PROFIBUS DP network with max. 12 Mbit/s
- ④ PROFIBUS PA segment coupler DP / PA
- ⑤ PROFIBUS PA network with 31.25 kbit/s
- ⑥ HART® device
- ⑦ More devices with 4...20 mA
- ⑧ Analogue I/O module

Refer also to the PROFIBUS PA User and Installation Guideline (Version 2.2, February 2003 PNO Order No. 2.092).

## 3.2 Electrical connection for signal converter

### Bus cable - Shielding and grounding

The statements of the FISCO model only apply if the used bus cable meets the required specifications.

In order to ensure optimum electromagnetic compatibility of systems it is important that the system components, and in particular the bus cables, are shielded. These shields must have as few gaps as possible.



#### **INFORMATION!**

*The PROFIBUS PA interface of the signal converter will operate only if the power supply is connected/available. The device terminal is not sensitive to electrical polarity.*

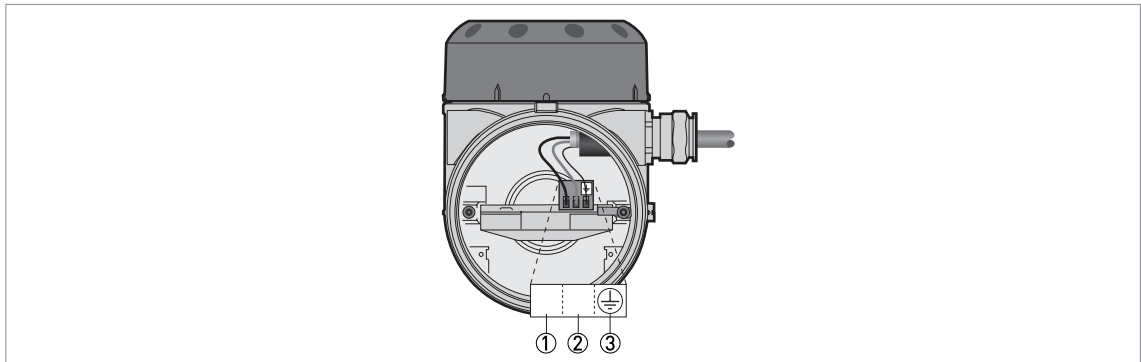

Figure 3-2: Electrical installation: terminals

- ① Power supply / communication terminal
- ② Power supply / communication terminal
- ③ Grounding terminal

Use the shortest possible length of shield wire to connect the electrical cable to the functional earth (FE) terminal.

## 4.1 Hardware settings

There is a DIP switch block with 8 switches on the level transmitter module to set the PROFIBUS device address and prevent changes to the station address from the network.

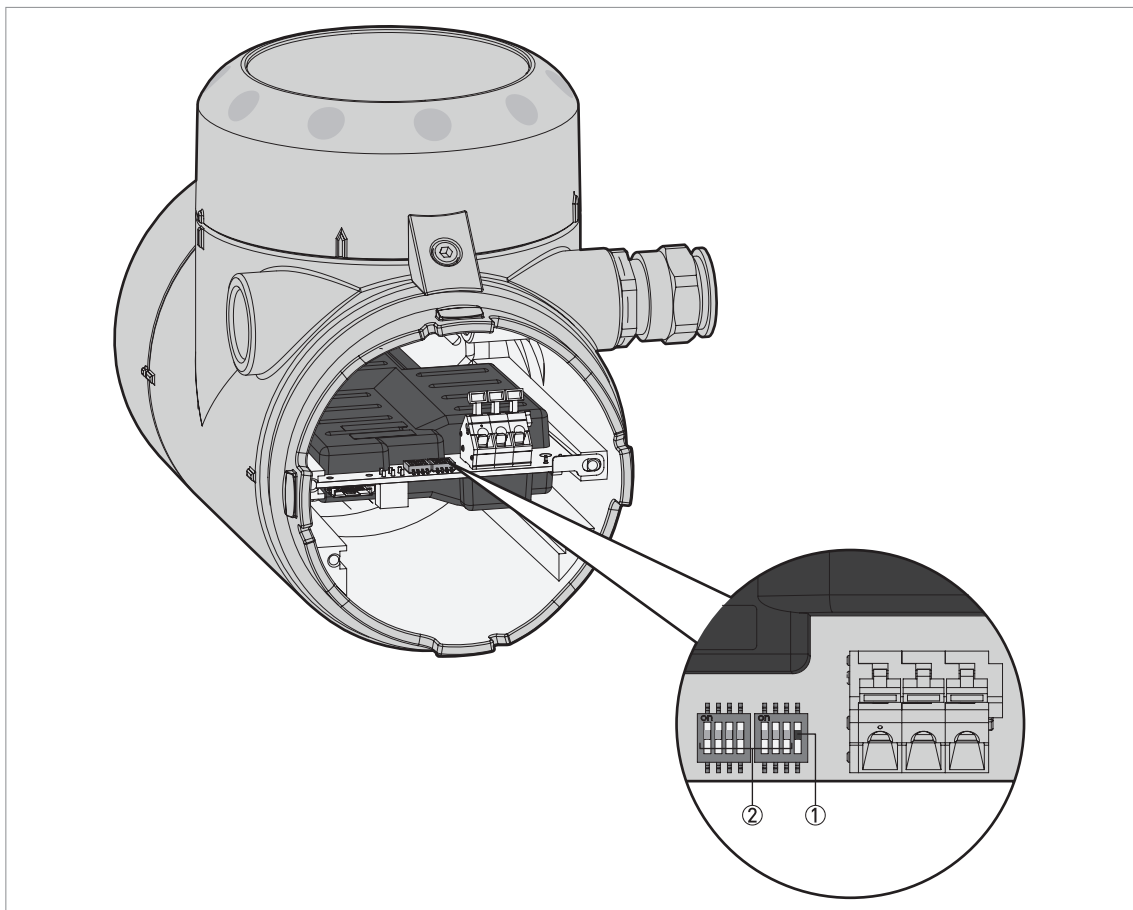

Figure 4-1: How to use the DIP switches to change the station address

- ① Hardware DIP switch
  - OFF: The user can set the station address with the network bus
  - ON: The user can set the address of the device with the 7 other DIP switches (item ②). You cannot use the network bus or the local display to change the station address.
- ② 7 "Station Address" DIP switches. Each DIP switch is a bit position (bits 0..6). Bit 0 is on the left side of the switch block. The base 10 value of each bit is given in the table that follows. This data is used to calculate the "Station Address" number.
  - OFF: binary number "0".
  - ON: binary number "1".



### **INFORMATION!**

*If the Hardware DIP switch is set to "ON", the hardware is locked and you cannot use the network bus to change the station address.*

### Station address: DIP switch positions

Function	Bit	DIP switch positions	
		Value ("OFF")	Value ("ON")
Hardware ①	7	OFF	ON
Station address	6	+ 0	+ 64
	5	+ 0	+ 32
	4	+ 0	+ 16
	3	+ 0	+ 8
	2	+ 0	+ 4
	1	+ 0	+ 2
	0	+ 0	+ 1

① If this DIP switch is set to "ON", you cannot use the network bus to change the station address

The station address is calculated by adding the "ON" values of each switch on the DIP switch block. The default setting for each switch is "OFF".

### Station address

- If the "Station Address" DIP switches are set to a correct station address ( $\leq 125$ ), the device uses this address. The Set\_Slave\_Add service is not used. Automatic Ident. Number adaptation is not possible via Set\_Slave\_Add service in this case. Physical block parameter FACTORY\_RESET code 2712 (reset station address to its default value) is rejected.
- If the "Station Address" DIP switches are set to an incorrect address ( $> 125$ ), the device ignores this setting. The Set\_Slave\_Add service and the Physical block parameter FACTORY\_RESET code 2712 (reset station address to its default value) are used. If No\_add\_Cfg flag is set to "ON", the device will continue to use FACTORY\_RESET code 2712.
- If the "Station Address" DIP switches are changed from an incorrect address to a correct address, the device uses the address set on the DIP switch block.
- If the "Station Address" DIP switches are changed from a correct address to an incorrect address, the device will use the default address 126. The flag No\_Add\_Chg will be set back to "OFF".



#### **INFORMATION!**

You can also use the local display (menu item 2.6.1 ADDRESS) to set the Station Address to a new value. You can change the value when the Hardware DIP switch is "OFF". If the Hardware DIP switch is "ON", you can see the Station Address on the local display screen but you cannot change the value.

## 4.2 GSD files

The GSD file contains information that will be needed for configuration of the PROFIBUS DP communication network. Supplementary files (e.g. \_\_\_\_.bmp and \_\_\_\_.dib) contain icons which will represent the PROFIBUS devices in the view of the bus configuration system/master system. The files must be loaded into the configuration program before you connect the device to the network. Follow the instructions in the manual of the host supplier when installing GSD file and supplementary files.

The GSD files of all KROHNE devices with PROFIBUS PA interface are available at the KROHNE internet site for download.



### **INFORMATION!**

*If it is supported by the host configuration tool the device entry for the level meter will be located within the slave family "PROFIBUS PA".*

## 4.3 Ident. Number

### **Manufacturer specific Ident. Number (4554hex)**

This setting gives a complete set of operations that can be run on the device. All Function Blocks (4 AI-FB) are used for cyclic data transfer. Device-specific diagnosis data is transferred in addition to the Profile diagnosis.

### **Cyclic layout:**

Slot	Function Block	Valid GSD Modules
1	AI-FB	Empty Module AI: Out

It is necessary to use GSD file KR014554.GSD in this mode. It is possible to use this file for all types of PROFIBUS DP/PA segment couplers.



### **INFORMATION!**

*If a different GSD file is used in the PROFIBUS master system, it is not possible to transfer cyclic data.*

**Profile specific Ident. Number (9700hex)**

The 4 AI-FB are available only for cyclic data transfer. Cyclic PROFIBUS services cannot supply device-specific diagnosis data. This operational condition can make devices from different suppliers operate better together. The system will only use functions that are available to all PROFIBUS PA level transmitters. It is not necessary to change the settings of the control system to transfer data.

**Cyclic layout:**

Slot	Function Block	Valid GSD Modules
1	AI-FB	Analog Input (AI) short Analog Input (AI) long

It is necessary to use GSD file PA139700.GSD in this mode. This file is supplied by PROFIBUS International (refer to [www.profibus.com](http://www.profibus.com)). It is possible to use this file for all types of PROFIBUS DP/PA segment couplers. If this file is used, "Condensed Status" is not available.

**INFORMATION!**

*If a different GSD file is used in the PROFIBUS master system, it is not possible to transfer cyclic data.*

**4.4 Configuration of cyclic data transfer**

During network configuration the user has to select which function block input/output data shall be transferred between the PROFIBUS master and the PROFIBUS slave. The GSD file described above contains several types of modules for this purpose. During configuration a module has to be assigned to each slot of the device in order to select which data has to be transferred for the corresponding function blocks. The cyclic layout (see section Ident. Number selector) shows which module types are valid for each slot. The order of transmission of the data always remains the same. If an "Empty Module" is assigned to a slot no data will be sent for the corresponding function block and all function block data following this empty module will move up one position.

## 4.5 Cyclic data

In a PROFIBUS network cyclic data is described from the point of view of the master. Therefore input data is transferred from the slave to the master while output data is transferred from the master to the slave.

### 4.5.1 Input data

Input data is transferred from the level transmitter to the master for the measuring value. If input data transfer is configured, 5 bytes are transferred for the corresponding slot:

- 4 byte float value (Float Format according to IEEE Standard 754 Short Real Number)
- 1 byte status value

#### Float value

The example that follows shows the format of the float value according to IEEE Standard 754 Short Real Number:

#### Float format

Byte n								Byte n+1							
Bit7	Bit6							Bit7	Bit6						
VZ	$2^7$	$2^6$	$2^5$	$2^4$	$2^3$	$2^2$	$2^1$	$2^0$	$2^{-1}$	$2^{-2}$	$2^{-3}$	$2^{-4}$	$2^{-5}$	$2^{-6}$	$2^{-7}$
	Exponent							Mantissa							

Byte n+2								Byte n+3							
Bit7								Bit7							
$2^{-8}$	$2^{-9}$	$2^{-10}$	$2^{-11}$	$2^{-12}$	$2^{-13}$	$2^{-14}$	$2^{-15}$	$2^{-16}$	$2^{-17}$	$2^{-18}$	$2^{-19}$	$2^{-20}$	$2^{-21}$	$2^{-22}$	$2^{-23}$
Mantissa								Mantissa							

Example (binary): 40 F0 00 00 (hex) = 0100 0000 1111 0000 0000 0000 0000 0000

#### Formula:

$$\text{value} = (-1)^{VZ} * 2^{(\text{Exponent} - 127)} * (1 + \text{Mantissa})$$

$$\text{value} = (-1)^0 * 2^{(129 - 127)} * (1 + 2^{-1} + 2^{-2} + 2^{-3})$$

$$\text{value} = 1 * 4 * (1 + 0.5 + 0.25 + 0.125)$$

$$\text{value} = 7.5$$

### Status value

The PROFIBUS interface of the level transmitter supports the PROFIBUS-PA Profile Version 3.02. In this Profile the Condensed Status and Diagnosis has replaced by default the Classic Status and Diagnosis of the PROFIBUS-PA Profile Version 3.0. The Condensed Status and Diagnosis has been created to make diagnostic events more obvious and to allow predictive and preventive maintenance. Nevertheless Classic Status and Diagnosis is still available for the level transmitter. It is implemented for backwards compatibility to "older" devices or PLC systems which do not support Condensed Status and Diagnosis.

The device may be switched between "Condensed Status and Diagnosis" and "Classic Status and Diagnosis"

- automatically during start-up of the cyclic data transfer by setting the parameter PRM\_COND within the Set\_Prm service data.
- using an engineering tool (e.g. DD/DTM) to write the parameter COND\_STATUS\_DIAG (slot 0, index 43).

### Coding for both parameters is:

- 0: Classic Status
- 1: Condensed Status (factory setting)



#### **INFORMATION!**

*The parameter COND\_STATUS\_DIAG cannot be modified directly if cyclic data transfer is active. Nevertheless it is reset to the factory setting if a reset to default data is requested by an engineering tool.*

The coding of the status value depends on the active status and diagnosis mode. It is described in the following tables.

### Condensed Status

The Condensed Status codes have been defined to allow easier decoding of the information provided by the PROFIBUS devices. The coding is shown in the following table:

Quality		Quality substatus				Limits		
Gr	Gr	QS	QS	QS	QS	Qu	Qu	
$2^7$	$2^6$	$2^5$	$2^4$	$2^3$	$2^2$	$2^1$	$2^0$	
0	0							= bad
0	1							= uncertain
1	0							= good (Non Cascade)
1	1							= good (Cascade) - not supported

## Status = bad

Quality		Quality substatus				Limits		
Gr	Gr	QS	QS	QS	QS	Qu	Qu	
$2^7$	$2^6$	$2^5$	$2^4$	$2^3$	$2^2$	$2^1$	$2^0$	
0	0	0	0	0	0	0	0	= non-specific (not provided by the device)
0	0	1	0	0	0	1	1	= passivated (diagnostic alerts inhibited)
0	0	1	0	0	1	x	x	= maintenance alarm, more diagnosis available
0	0	1	0	1	0	x	x	= process related, no maintenance
0	0	1	1	1	1	x	x	= function check / local override; value not usable

## Status = uncertain

Quality		Quality substatus				Limits		
Gr	Gr	QS	QS	QS	QS	Qu	Qu	
$2^7$	$2^6$	$2^5$	$2^4$	$2^3$	$2^2$	$2^1$	$2^0$	
0	1	0	0	1	0	x	x	= substitute set
0	1	0	0	1	1	1	1	= initial value
0	1	1	0	1	0	x	x	= maintenance demanded
0	1	1	1	0	0	1	1	= simulated value, start
0	1	1	1	0	1	1	1	= simulated value, end
0	1	1	1	1	0	x	x	= process related, no maintenance

## Status = good (Non Cascade)

Quality		Quality substatus				Limits		
Gr	Gr	QS	QS	QS	QS	Qu	Qu	
$2^7$	$2^6$	$2^5$	$2^4$	$2^3$	$2^2$	$2^1$	$2^0$	
1	0	0	0	0	0	x	x	= ok
1	0	0	0	0	1	x	x	= update event
1	0	0	0	1	0	x	x	= advisory alarm
1	0	0	0	1	1	x	x	= critical alarm
1	0	1	0	0	0	x	x	= initiate fail safe (not provided by the level transmitter)
1	0	1	0	0	1	x	x	= maintenance required
1	0	1	0	1	0	x	x	= maintenance demanded
1	0	1	1	1	1	x	x	= function check

### Status = Limits

Quality		Quality substatus				Limits		
Gr	Gr	QS	QS	QS	QS	Qu	Qu	
2 <sup>7</sup>	2 <sup>6</sup>	2 <sup>5</sup>	2 <sup>4</sup>	2 <sup>3</sup>	2 <sup>2</sup>	2 <sup>1</sup>	2 <sup>0</sup>	
						0	0	= ok
						0	1	= low limited
						1	0	= high limited
						1	1	= constant

Check the first two quality bits in order to get the quality information of the measurement value:

- **Good (Non Cascade):** function block output value is ok and can be used without restrictions
- **Good (Cascade):** will not be supported, because it is not applicable for the device
- **Uncertain:** function block output value can be used but the accuracy can not be guaranteed (function block outputs value has been frozen, A/D converter is saturated or out of range, ...)
- **Bad:** function block output value is bad - do not use it for process control!

The "Quality-Substatus" and "Limit" bits will be used for further diagnostics or limit checking.



#### **INFORMATION!**

*The status should be monitored because a number will be transmitted even if the status of the measurement value is bad or uncertain. This is the only way to check the quality of the transmitted measurement values.*

### Classic Status

The Classic Status is implemented to provide compatibility to systems which are not configured for Condensed Status. The coding is shown in the following table:

Quality		Quality substatus				Limits		
Gr	Gr	QS	QS	QS	QS	Qu	Qu	
2 <sup>7</sup>	2 <sup>6</sup>	2 <sup>5</sup>	2 <sup>4</sup>	2 <sup>3</sup>	2 <sup>2</sup>	2 <sup>1</sup>	2 <sup>0</sup>	
0	0							= bad
0	1							= uncertain
1	0							= good (Non Cascade)
1	1							= good (Cascade) - not supported

**Status = bad**

Quality		Quality substatus				Limits		
Gr	Gr	QS	QS	QS	QS	Qu	Qu	
2 <sup>7</sup>	2 <sup>6</sup>	2 <sup>5</sup>	2 <sup>4</sup>	2 <sup>3</sup>	2 <sup>2</sup>	2 <sup>1</sup>	2 <sup>0</sup>	
0	0	0	0	0	0			= non-specific
0	0	0	0	0	1			= configuration error
0	0	0	0	1	0			= not connected
0	0	0	0	1	1			= device failure
0	0	0	1	0	0			= sensor failure
0	0	0	1	0	1			= no communication (last usable value)
0	0	0	1	1	0			= no communication (no usable value)
0	0	0	1	1	1			= out of service

**Status = uncertain**

Quality		Quality substatus				Limits		
Gr	Gr	QS	QS	QS	QS	Qu	Qu	
2 <sup>7</sup>	2 <sup>6</sup>	2 <sup>5</sup>	2 <sup>4</sup>	2 <sup>3</sup>	2 <sup>2</sup>	2 <sup>1</sup>	2 <sup>0</sup>	
0	1	0	0	0	0			= non-specific
0	1	0	0	0	1			= last usable value
0	1	0	0	1	0			= substitute-set
0	1	0	0	1	1			= initial value
0	1	0	1	0	0			= sensor conversion not accurate
0	1	0	1	0	1			= engineering unit violation (unit not in the valid set)
0	1	0	1	1	0			= sub-normal
0	1	0	1	1	1			= configuration error
0	1	1	0	0	0			= simulated value

**Status = good (Non Cascade)**

Quality		Quality substatus				Limits		
Gr	Gr	QS	QS	QS	QS	Qu	Qu	
2 <sup>7</sup>	2 <sup>6</sup>	2 <sup>5</sup>	2 <sup>4</sup>	2 <sup>3</sup>	2 <sup>2</sup>	2 <sup>1</sup>	2 <sup>0</sup>	
1	0	0	0	0	0			= ok
1	0	0	0	0	1			= update event
1	0	0	0	1	0			= active advisory alarm
1	0	0	0	1	1			= active critical alarm
1	0	0	1	0	0			= unacknowledged update event
1	0	0	1	0	1			= unacknowledged advisory alarm
1	0	0	1	1	0			= unacknowledged critical alarm
1	0	1	0	0	0			= initiate fail safe
1	0	1	0	0	1			= maintenance required

### Status = Limits

Quality		Quality substatus				Limits		
Gr	Gr	QS	QS	QS	QS	Qu	Qu	
2 <sup>7</sup>	2 <sup>6</sup>	2 <sup>5</sup>	2 <sup>4</sup>	2 <sup>3</sup>	2 <sup>2</sup>	2 <sup>1</sup>	2 <sup>0</sup>	
						0	0	= ok
						0	1	= low limited
						1	0	= high limited
						1	1	= constant

Check the first two quality bits in order to get the quality information of the measurement value:

- **Good (Non Cascade):** function block output value is ok and can be used without restrictions
- **Good (Cascade):** will not be supported, because it is not applicable for the device
- **Uncertain:** function block output value can be used but the accuracy can not be guaranteed (function block outputs value has been frozen, A/D converter is saturated or out of range, ...)
- **Bad:** function block output value is bad - do not use it for process control!

The "Quality-Substatus" and "Limit" bits will be used for further diagnostics or limit checking.



#### **INFORMATION!**

*The status should be monitored because a number will be transmitted even if the status of the measurement value is bad or uncertain. This is the only way to check the quality of the transmitted measurement values.*

## 4.6 Diagnosis

The device does internal self-tests. The results are given as detailed diagnosis data that agrees with PROFIBUS PA Profile 3.02. You can set device parameters to see the diagnosis data and you can also use an engineering tool (DD/DTM, ...) to read it. Cyclic services transfer diagnosis data to the control system (PLC, ...).

Diagnosis is bitwise coded. Thus it is possible to report more than one indication simultaneously. The GSD file contains a text for each diagnosis bit to show a text message in the control system. The references are specified in the UNIT\_DIAG\_BIT(i) entries. They show which bit is set to indicate a special diagnosis event.

The quantity and content of diagnosis data depends on the device settings. The active Ident. Number and the selected status and diagnosis mode will have an effect diagnosis propagation. The tables that follow show the diagnosis events which are reported for different settings. The bit number is equal to the count in the GSD file. It gives the position in the device-related diagnostic field of the Slave\_Diag service.

#### **Diagnosis to control system in case of**

- Manufacturer specific Ident. Number (4554hex)
- Profile specific Ident. Number (9700hex)

Bit Number	supported	Description	Corrective action
16	yes	Error appears	-
17	yes	Error disappears	-
24	①	Hardware failure electronics	Restart the device. If the error occurs again: send the device back to the manufacturer with an indication of the error.
27	①	Electronic temperature too low	Electronic temperature below -40°C. Comply with the application limits with regard to temperature of the medium and ambient temperature. If the process conditions are within the specified limits: send the device back to the manufacturer with an indication of the error.
		Electronic temperature too high	Electronic temperature above +85°C. Comply with the application limits with regard to temperature of the medium and ambient temperature. If the process conditions are within the specified limits: send the device back to the manufacturer with an indication of the error.
28	①	Memory error	Reset the device to Factory/Default settings. If the error occurs again: send the device back to the manufacturer with an indication of the error.
29	①	Measurement failure	Check process conditions (Flow/Level, Temperature). If the process conditions are within the specified limits: send the device back to the manufacturer with an indication of the error.
34	①	Configuration invalid	Reset the device to Factory/Default settings. If the error occurs again: send the device back to the manufacturer with an indication of the error.
35	yes	Restart	Device is restarted because of power-up or warmstart request. In case of unexpected restart: send the device back to the manufacturer with an indication of the error.
36	yes	Coldstart	Device is reset to its Factory/Default settings because of a user request or exchange of the basic module (serial number is changed). Recover user specific parameter settings.
37	yes	Maintenance required	Linearization or temperature compensation is not operating correct. See for detailed failure message or send the device back to the manufacturer with an indication of the error.
39	yes	Ident_Number violation	Ident. Number Selector was modified while cyclic data transfer was active. To clear this message perform one of the following actions: <ul style="list-style-type: none"> <li>• Reset Ident. Number Selector to its former setting</li> <li>• Stop cyclic data transfer</li> <li>• Restart the device</li> </ul>
40	②	Maintenance alarm	Check detailed diagnosis. Restart the device. If the error occurs again: send the device back to the manufacturer with an indication of the error.
42	②	Function check	Simulation is active. Disable simulation to clear this message.
43	②	Invalid process condition	Check process conditions (Flow/Level, Temperature). If the process conditions are within the specified limits: send the device back to the manufacturer with an indication of the error.
55	yes	Extension available	Refer to detailed diagnosis in bits 56 to 103.
56	③	Converter EEPROM Error	Replace the signal converter. For more data, refer to the handbook.
57	③	Converter RAM Error	Replace the signal converter. For more data, refer to the handbook.

Bit Number	supported	Description	Corrective action
58	③	Converter ROM Error	Replace the signal converter. For more data, refer to the handbook.
59	③	Sensor EEPROM Error	Replace the signal converter. For more data, refer to the handbook.
60	③	Sensor RAM Error	Replace the signal converter. For more data, refer to the handbook.
61	③	Sensor ROM Error	Replace the signal converter. For more data, refer to the handbook.
63	③	Oscillator Frequency Failure	Replace the signal converter. For more data, refer to the handbook.
64	③	Converter Voltage Error	Replace the signal converter. For more data, refer to the handbook.
65	③	Sensor Voltage Error	Do a check of the power supply at the device terminals. Make sure that voltage values are in the specified limits in menu item 2.2.2 DIAGNOSTIC (Configuration mode / Supervisor menu). If the voltage is correct, replace the signal converter. For more data on how to replace the signal converter, refer to the handbook.
66	③	Internal Communication Error	De-energize the device. Make sure that the signal cable engages in the terminal and the screw connection is tight. Energize the device. If the problem continues, replace the signal converter. For more data, refer to the handbook.
67	③	Temperature Out of Range Error	Measure the ambient temperature. Deenergize the device until the ambient temperature is back in the given range. If the temperature does not stay in the correct range, make sure that there is insulation around the signal converter. If this error occurs 2 times, replace the device.
68	③	Sensor not compatible	Go to menu 1.1.0 IDENT. in Configuration mode. Record the version numbers of the device software given in menu items 1.1.2, 1.1.3 and 1.1.4. Give this data to the supplier.
69	③	Sensor no signal	Replace the signal converter. For more data, refer to the handbook.
72	③	Peak Lost Error	Do a check of the device, tank and the process. Reconfigure the device and record a new empty spectrum. Follow the instructions in the handbook. If necessary, speak to the supplier.
73	③	Overfill Error	Use a different procedure to measure the level in the tank. Remove some of the product until the level is below the blocking distance.  If a viscous product touched the antenna: <ul style="list-style-type: none"> <li>• remove the device and clean the antenna, or</li> <li>• if the device has a purging option, use the purging system to clean the antenna.</li> </ul>
82	③	Empty spectrum invalid	Record a new empty spectrum. Follow the instructions in the handbook.
83	③	Signal weak	If this error occurs frequently, it is possible that you must install the device in a stilling well or use a different antenna type.
84	③	Signal strong	No corrective action is necessary.
85	③	Bad measurement quality	Record the process with the PACTware™ software tool to find the cause of the problem. If necessary, speak to the supplier.

Bit Number	supported	Description	Corrective action
86	③	Temperature Below -35°C	Measure the ambient temperature. De-energize the device until the ambient temperature is back in the given range. If the temperature does not stay in the correct range, make sure that there is insulation around the signal converter.
87	③	Temperature Above +75°C	Measure the ambient temperature. De-energize the device until the ambient temperature is back in the given range. If the temperature does not stay in the correct range, make sure that there is insulation around the signal converter.
90	③	Temperature out of range warning	Measure the ambient temperature. De-energize the device until the ambient temperature is back in the given range. If the temperature does not stay in the correct range, make sure that there is insulation around the signal converter.
93	③	Local Operation	The device is in configuration mode. A supervisor has used the LCD display of the device to enter a menu. Use the LCD display to go back to normal mode.
100	③	No OW5200C Connection	De-energize the device. Make sure that the signal cable engages in the terminal and the screw connection is tight. Energize the device. If the problem continues, replace the signal converter. For more data, refer to the handbook.

① Indication is supported if Classic Diagnosis is active only.

② Indication is supported if Condensed Diagnosis is active only.

③ Indication is supported in cyclic diagnosis only if Ident. Number 4554 hex is active. Nevertheless this information is always available via acyclic access (e.g. by using DD / DTM) for all Ident. Numbers supported.









### KROHNE product overview

- Electromagnetic flowmeters
- Variable area flowmeters
- Ultrasonic flowmeters
- Mass flowmeters
- Vortex flowmeters
- Flow controllers
- Level meters
- Temperature meters
- Pressure meters
- Analysis products
- Products and systems for the oil & gas industry
- Measuring systems for the marine industry

Head Office KROHNE Messtechnik GmbH  
Ludwig-Krohne-Str. 5  
47058 Duisburg (Germany)  
Tel.: +49 (0)203 301 0  
Fax: +49 (0)203 301 10389  
info@krohne.de

The current list of all KROHNE contacts and addresses can be found at:  
[www.krohne.com](http://www.krohne.com)

**KROHNE**