



## OPTIMASS 1400 Handbook

Sensor for mass flow

The documentation is only complete when used in combination with the relevant documentation for the signal converter.

All rights reserved. It is prohibited to reproduce this documentation, or any part thereof, without the prior written authorisation of KROHNE Messtechnik GmbH.

Subject to change without notice.

Copyright 2019 by  
KROHNE Messtechnik GmbH - Ludwig-Krohne-Str. 5 - 47058 Duisburg (Germany)

<b>1</b>	<b>Safety instructions</b>	<b>5</b>
1.1	Intended use .....	5
1.2	CE certification .....	5
1.3	Associated documents .....	5
1.4	Pressure Equipment Directive (PED) .....	6
1.5	Dirty gas .....	6
1.6	Safety instructions from the manufacturer .....	7
1.6.1	Copyright and data protection .....	7
1.6.2	Disclaimer .....	7
1.6.3	Product liability and warranty .....	7
1.6.4	Information concerning the documentation .....	8
1.6.5	Warnings and symbols used .....	9
1.7	Safety instructions for the operator .....	9
<b>2</b>	<b>Device description</b>	<b>10</b>
2.1	Scope of delivery .....	10
2.1.1	Meters with hygienic connections .....	11
2.2	Nameplates .....	11
2.3	CSA Dual Seal .....	11
2.4	Temperature differential and thermal shock .....	13
<b>3</b>	<b>Installation</b>	<b>14</b>
3.1	General notes on installation .....	14
3.2	Storage .....	14
3.3	Handling .....	15
3.4	Installation conditions .....	17
3.4.1	Supporting the meter .....	17
3.4.2	Mounting the meter .....	18
3.4.3	Cross talk .....	19
3.4.4	Flange connections .....	19
3.4.5	Maximum pipework forces (end loadings) .....	20
3.4.6	Pipework reducers .....	21
3.4.7	Flexible connections .....	21
3.4.8	Hygienic installations .....	21
3.4.9	Heating and insulation .....	22
3.4.10	Purge ports .....	24
3.4.11	Zero calibration .....	24
3.4.12	Sunshades .....	25
<b>4</b>	<b>Electrical connections</b>	<b>26</b>
4.1	Safety instructions .....	26
4.2	Electrical and I/O connections .....	26

5 Service	27
<hr/>	
5.1 Spare parts availability	27
5.2 Availability of services	27
5.3 Returning the device to the manufacturer	27
5.3.1 General information	27
5.3.2 Form (for copying) to accompany a returned device	28
5.4 Disposal	28
6 Technical data	29
<hr/>	
6.1 Measuring principle (twin tube)	29
6.2 Technical data	31
6.3 ATEX temperature limits	35
6.4 Maximum pipework forces (end loadings)	36
6.5 Guidelines for maximum operating pressure	37
6.6 Dimensions and weights	40
6.6.1 Flanged versions	40
6.6.2 NAMUR dimensions	44
6.6.3 Hygienic versions	45
6.6.4 Heating jacket version	49
6.6.5 Purge port option	50
7 Notes	51
<hr/>	

## 1.1 Intended use

This mass flowmeter is designed for the direct measurement of mass flow rate, product density and product temperature. Indirectly, it also enables the measurement of parameters like total mass, concentration of dissolved substances and the volume flow. For use in hazardous areas, special codes and regulations are also applicable and these are specified in a separate documentation.

**CAUTION!**

*Responsibility for the use of the measuring devices with regard to suitability, intended use and corrosion resistance of the used materials against the measured fluid lies solely with the operator.*

**INFORMATION!**

*This device is a Group 1, Class A device as specified within CISPR11:2009. It is intended for use in industrial environment. There may be potential difficulties in ensuring electromagnetic compatibility in other environments, due to conducted as well as radiated disturbances.*

**INFORMATION!**

*The manufacturer is not liable for any damage resulting from improper use or use for other than the intended purpose.*

## 1.2 CE certification

CE marking



This device conforms with the most recent and up to date versions of the following:

- EMC Directive
- ATEX Directive
- Low Voltage Directive
- Pressure Equipment Directive
- RoHS
- Measuring Instrument Directive

The manufacturer declares conformity and the device carries the CE mark.

## 1.3 Associated documents

This handbook should be read in conjunction with relevant documents in relation to:

- hazardous areas
- communications
- concentration
- corrosion

## 1.4 Pressure Equipment Directive (PED)



### **LEGAL NOTICE!**

*The Pressure Equipment Directive places legal requirements on both the manufacturer and the end user. Please read this section carefully!*

To ensure the PED integrity of the meter, you **MUST** check that the serial numbers on the transmitter nameplate and the sensor nameplate are the same.

To comply with the requirements of the Pressure Equipment Directive (PED) the manufacturer provides all the relevant technical data in the technical data section of this handbook. In addition to which, the following should also be noted:

- Secondary pressure containment is NOT supplied as standard.
- The non PED / CRN approved outer cylinder has a typical burst pressure greater than 100 barg / 1450 psig at 20°C / 68°F.
- The wiring feedthrough is made of Epoxy, PPS or PEEK with two O-rings made from FPM / FKM & Hydrogenated Nitrile.
- If the measuring tube/s fails, the O-ring and feedthrough will be in contact with the process product.
- You **MUST** make sure that the O-ring ring and feedthrough material is suitable for the application.
- Alternative O-ring materials are available on request.

### **Secondary pressure containment**

Where the meter is being used to measure high pressure gases and / or gases kept as liquids by high pressure and / or where there is a risk of tube failure because of the use of corrosive or erosive fluids, frequent pressure and / or thermal cycling, seismic or other shock loading, a secondary containment option **MUST** be purchased

Where the above situation applies and the process pressure exceeds the secondary pressure containment (please refer to technical data) or where secondary pressure containment is not available, the burst disc option **MUST** also be purchased. For more information, please contact your nearest representative.



### **DANGER!**

*If it is suspected that the primary measuring tube has failed, de-pressurise the meter and remove it from service as soon as it is safe to do so.*

## 1.5 Dirty gas

Dirty gas is gas that carries sand or other solid particles. Dirty gas causes excessive wear to the primary measuring tube that can eventually result in complete tube failure. In some situations tube failure where gas is being measured, can be very dangerous.



### **DANGER!**

*If the meter is being used to measure gas and there is a risk that the gas might be dirty, you must fit a filter upstream of the meter to catch solid particles.*

## 1.6 Safety instructions from the manufacturer

### 1.6.1 Copyright and data protection

The contents of this document have been created with great care. Nevertheless, we provide no guarantee that the contents are correct, complete or up-to-date.

The contents and works in this document are subject to copyright. Contributions from third parties are identified as such. Reproduction, processing, dissemination and any type of use beyond what is permitted under copyright requires written authorisation from the respective author and/or the manufacturer.

The manufacturer tries always to observe the copyrights of others, and to draw on works created in-house or works in the public domain.

The collection of personal data (such as names, street addresses or e-mail addresses) in the manufacturer's documents is always on a voluntary basis whenever possible. Whenever feasible, it is always possible to make use of the offerings and services without providing any personal data.

We draw your attention to the fact that data transmission over the Internet (e.g. when communicating by e-mail) may involve gaps in security. It is not possible to protect such data completely against access by third parties.

We hereby expressly prohibit the use of the contact data published as part of our duty to publish an imprint for the purpose of sending us any advertising or informational materials that we have not expressly requested.

### 1.6.2 Disclaimer

The manufacturer will not be liable for any damage of any kind by using its product, including, but not limited to direct, indirect or incidental and consequential damages.

This disclaimer does not apply in case the manufacturer has acted on purpose or with gross negligence. In the event any applicable law does not allow such limitations on implied warranties or the exclusion of limitation of certain damages, you may, if such law applies to you, not be subject to some or all of the above disclaimer, exclusions or limitations.

Any product purchased from the manufacturer is warranted in accordance with the relevant product documentation and our Terms and Conditions of Sale.

The manufacturer reserves the right to alter the content of its documents, including this disclaimer in any way, at any time, for any reason, without prior notification, and will not be liable in any way for possible consequences of such changes.

### 1.6.3 Product liability and warranty

The operator shall bear responsibility for the suitability of the device for the specific purpose. The manufacturer accepts no liability for the consequences of misuse by the operator. Improper installation or operation of the devices (systems) will cause the warranty to be void. The respective "Standard Terms and Conditions" which form the basis for the sales contract shall also apply.

### **1.6.4 Information concerning the documentation**

To prevent any injury to the user or damage to the device it is essential that you read the information in this document and observe applicable national standards, safety requirements and accident prevention regulations.

If this document is not in your native language and if you have any problems understanding the text, we advise you to contact your local office for assistance. The manufacturer can not accept responsibility for any damage or injury caused by misunderstanding of the information in this document.

This document is provided to help you establish operating conditions, which will permit safe and efficient use of this device. Special considerations and precautions are also described in the document, which appear in the form of icons as shown below.



### 1.6.5 Warnings and symbols used

Safety warnings are indicated by the following symbols.



**DANGER!**

*This warning refers to the immediate danger when working with electricity.*



**DANGER!**

*This warning refers to the immediate danger of burns caused by heat or hot surfaces.*



**DANGER!**

*This warning refers to the immediate danger when using this device in a hazardous atmosphere.*



**DANGER!**

*These warnings must be observed without fail. Even partial disregard of this warning can lead to serious health problems and even death. There is also the risk of seriously damaging the device or parts of the operator's plant.*



**WARNING!**

*Disregarding this safety warning, even if only in part, poses the risk of serious health problems. There is also the risk of damaging the device or parts of the operator's plant.*



**CAUTION!**

*Disregarding these instructions can result in damage to the device or to parts of the operator's plant.*



**INFORMATION!**

*These instructions contain important information for the handling of the device.*



**LEGAL NOTICE!**

*This note contains information on statutory directives and standards.*



• **HANDLING**

This symbol designates all instructions for actions to be carried out by the operator in the specified sequence.

➔ **RESULT**

This symbol refers to all important consequences of the previous actions.

## 1.7 Safety instructions for the operator



**WARNING!**

*In general, devices from the manufacturer may only be installed, commissioned, operated and maintained by properly trained and authorized personnel.  
This document is provided to help you establish operating conditions, which will permit safe and efficient use of this device.*

## 2.1 Scope of delivery

## Compact version

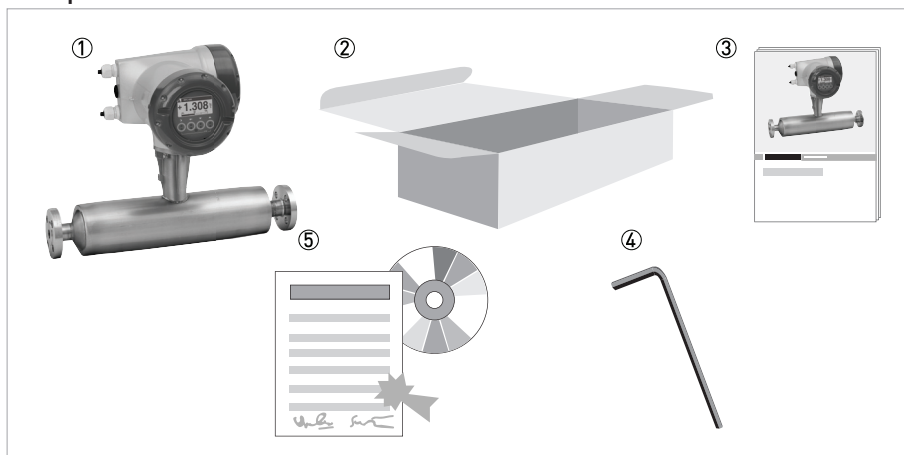

- ① Mass flowmeter.
- ② Carton.
- ③ Documentation.
- ④ 2.5 mm hex head tool.
- ⑤ CD-ROM and calibration certificate.

## Remote version

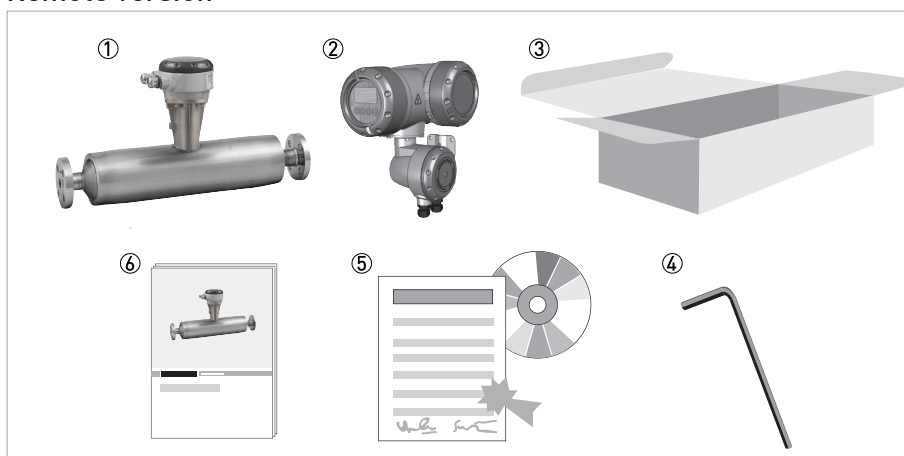

- ① Mass flowmeter.
- ② Converter. This will be either: field (as shown) or wall.
- ③ Carton.
- ④ 2.5 mm hex head tool.
- ⑤ CD-ROM and calibration certificate.
- ⑥ Documentation.

If any items are missing, please contact the manufacturer.

If your meter has flange connections, the flange specification is stamped on the outer edge of the flange. Check that the specification on the flange is the same as your order.

### 2.1.1 Meters with hygienic connections

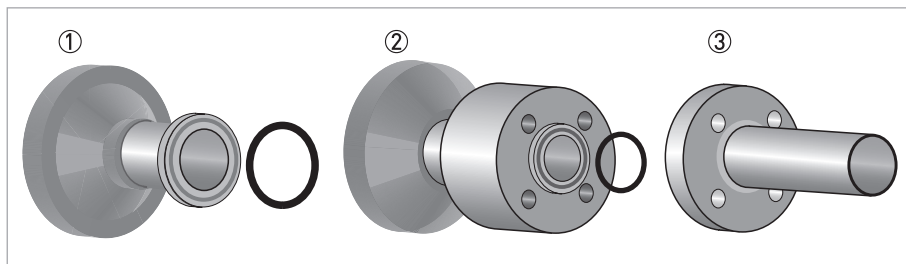

- ① Fully welded - the O-rings between the meter and the process pipework are not supplied as standard but can be ordered.
- ② DIN 11864-2 Form A - the O-rings between the Form A and Form B parts of the connection are not supplied as standard but can be ordered.
- ③ The 11864-2 Form B is not supplied as part of this connection but it can be ordered.

Inspect the condition of all seals between the meter and the process line (including seals supplied as part of the hygienic adapter) at regular intervals and replace them as necessary.

The time between inspections must be based on the seal material and the process conditions.

## 2.2 Nameplates



### **INFORMATION!**

*Look at the device nameplate to ensure that the device is delivered according to your order. Check for the correct supply voltage printed on the nameplate.*

## 2.3 CSA Dual Seal

To comply with the requirements of ANSI/ISA -12.27.01-2011 "Requirements for process Sealing Between electrical systems and Flammable or Combustible process Fluids" a secondary seal is incorporated into all OPTIMASS / GAS products. If the primary seal fails, the secondary seal will prevent escaping fluid reaching the electronic compartment.

Pressures and / or temperatures are limited by tube, temperature, connection and Ex limits. Check the meter nameplates and relevant documentation for full details. On all meters operating on gas measurement, the casing of the meter is fitted with a burst disc. If the primary seal (tube) fails leakage will occur from the burst disc. Install the meter so that the burst disc is pointing away from personnel.

### **Liquids**

#### **Pressure and temperature data:**

OPTIMASS 1400C -40°C...+130°C and 100...10000 kPa

If the primary seal fails, the casing of the meter will fill with liquid and the meter will stop working. The meter will notify the operator by displaying the status message "Sensor: Sensor signal low" on the converter or PLC display. This is an indication that the primary seal (tube) has failed and the status of the meter should be checked.

**Meter status:**

The meter will also display the message "Sensor: Sensor signal low" if the measuring tubes are not completely filled with fluid. For example, if the meter is drained or re/filled. To check the status of the meter, drain and re/fill with fluid and note the converter or PLC display. See the relevant section of the converter handbook for a list of status messages and diagnostics information.

If the meter continues to display the message: "Sensor: Sensor signal low" you **MUST** assume that the primary seal (tubes) has failed and the appropriate action **MUST** be taken.

**Gases****Pressure / temperature data:**

OPTIMASS 1400 -40°C...+130°C and 500...10000 kPa

Pressures and/or temperatures may be further limited by tube, temperature, connection and Ex limits. Consult the meter nameplate and relevant documentation for full details.

On all meters operating on gas measurement the casing of the meter is fitted with a burst disc. If the primary seal (tube/s) fails leakage will occur from the burst disc. Install the meter so that the burst disc is pointing away from personnel.

**Regular maintenance of the burst disc:**

Carry out regular maintenance checks on burst discs for leakage and/or blockages. On all OPTIMASS meters, the primary seal is considered to be the measuring tube of the meter. The materials of construction of the measuring tube/s are described within the relevant sections of this handbook and the customer's product and any other fluid flowing through the tube must be compatible with the material of construction. If failure of the primary seal is suspected then the process line should be de-pressurised and the meter removed as soon as it is safe to do so. Please contact customer service for servicing or replacement of the meter.

## 2.4 Temperature differential and thermal shock

### Temperature differential

The maximum difference between ambient temperature and process (operating) temperature is 110°C / 230°F.

### Thermal shock

Thermal shock occurs when there is a sudden and extreme change (shift) in process temperature. To avoid thermal shock, refer to the following table for the maximum temperature shift.

Meter	Maximum temperature shift
S15	+80°C / +176°F
S25	
S40	+110°C / +230°F
S50	



#### **CAUTION!**

*Operation outside these limits may result in shifts in density and mass flow calibration. Repeated shocking may also lead to premature failure of the meter! However, higher thermal shocks are possible at lower working pressures. For more information, please contact your nearest representative.*

### 3.1 General notes on installation

**INFORMATION!**

*Inspect the packaging carefully for damages or signs of rough handling. Report damage to the carrier and to the local office of the manufacturer.*

**INFORMATION!**

*Do a check of the packing list to make sure that you have all the elements given in the order.*

**INFORMATION!**

*Look at the device nameplate to ensure that the device is delivered according to your order. Check for the correct supply voltage printed on the nameplate.*

### 3.2 Storage

- Store the device in a dry and dust-free location.
- Avoid direct exposure to the sun.
- Store the device in its original packing.
- Do not allow the ambient temperature to fall below -50°C / -58°F or rise above +85°C / +185°F.

### 3.3 Handling

#### Using a sling to lift and carry the meter

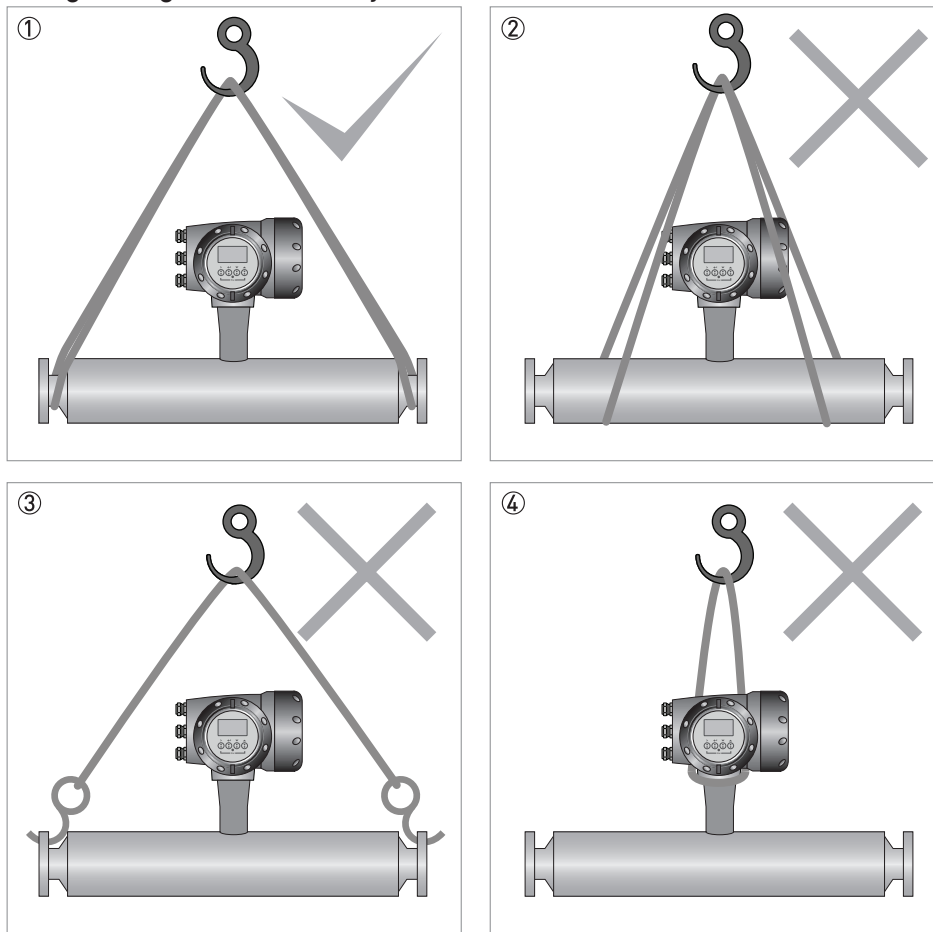

- ① Use a well maintained sling to lift the meter by the spigots.
- ② DO NOT lift the meter with the sling part way along the outer cylinder.
- ③ DO NOT lift the meter using the flange bolt holes.
- ④ DO NOT lift the meter by the converter housing or the electronics stem.

Standing the meter before installation

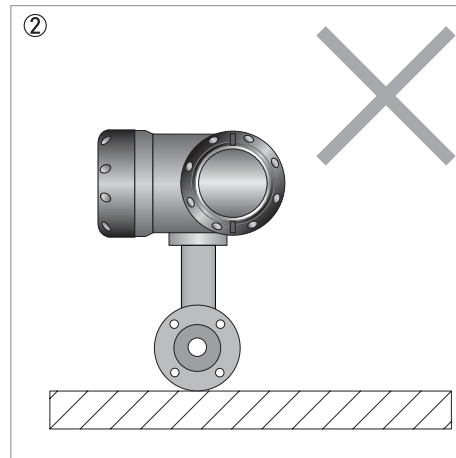
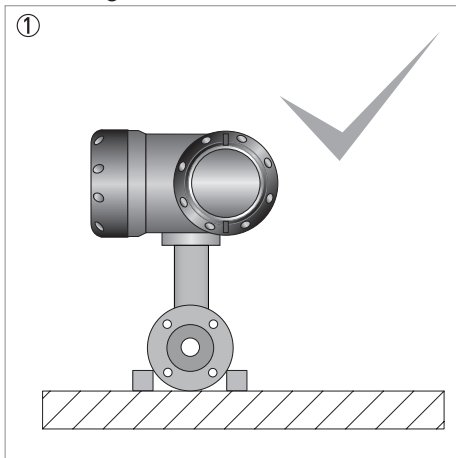

- ① When standing the meter prior to installation, use blocks or similar to keep the meter upright.
- ② NEVER stand the meter upright without blocks (or similar) .

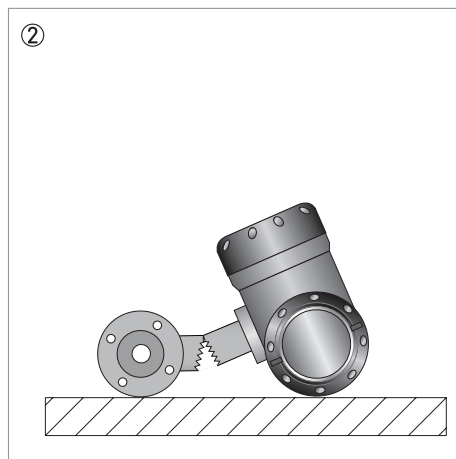
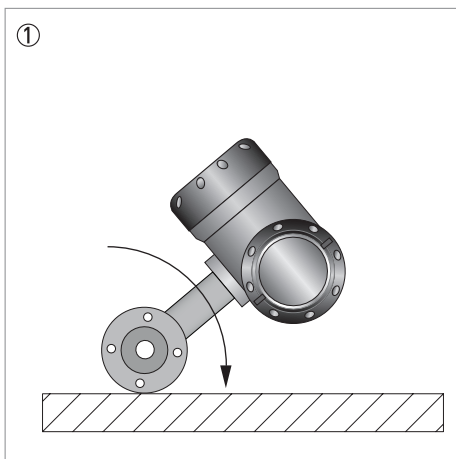

- ① If the meter is not blocked it can roll over
- ② This can cause severe damage to the meter, or injury to personnel



## 3.4 Installation conditions

### 3.4.1 Supporting the meter

#### Support for meters with flange connections

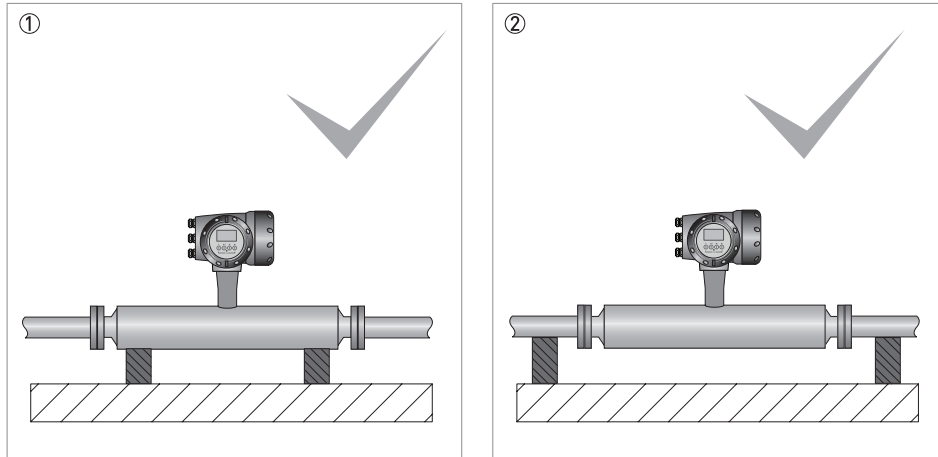

- ① The meter can be supported directly by its body
- ② The meter can also be supported by the process pipework

#### Support for meters with hygienic connections

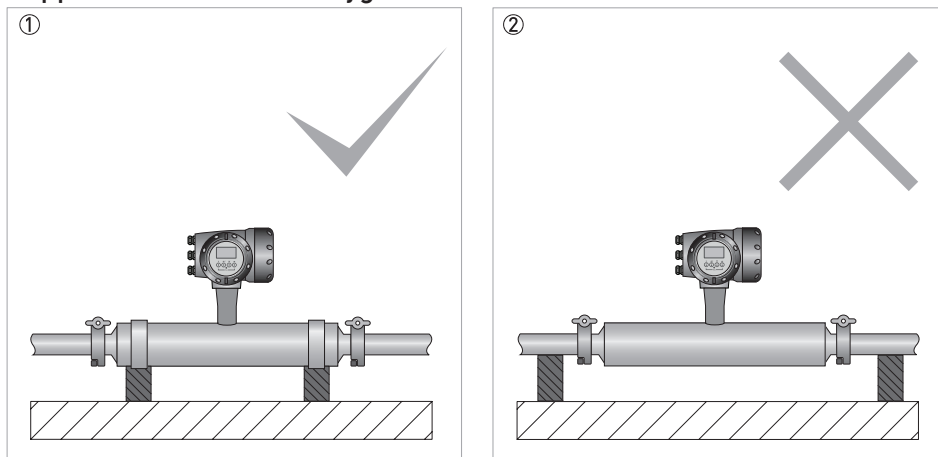

- ① Always support the meter body.
- ② DO NOT use the process pipework to support the weight of the meter. The thin wall of the pipework usually used in the hygienic industry, is not strong enough to carry the weight of the meter.

## 3.4.2 Mounting the meter

## Mounting positions

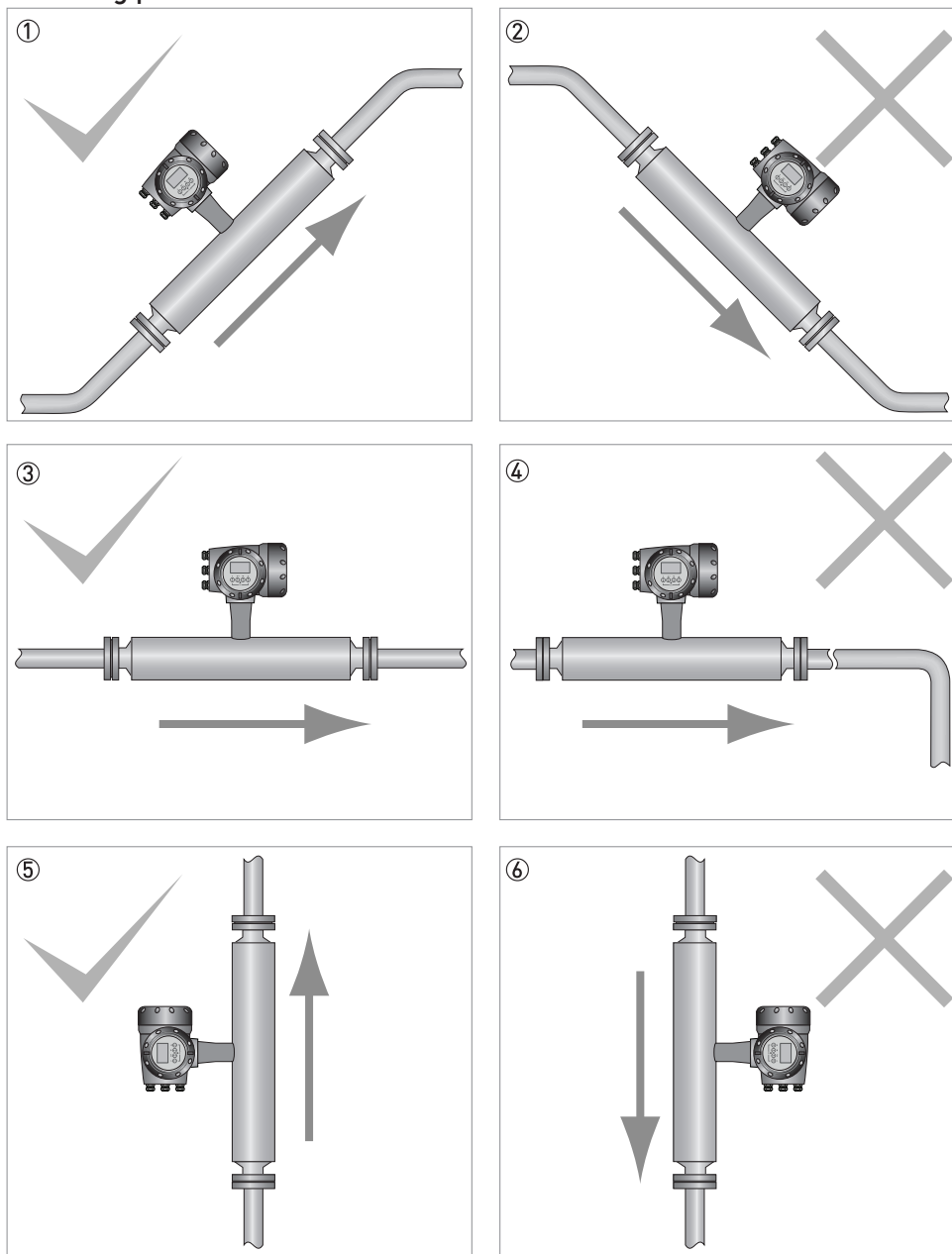

- ① The meter can be mounted at an angle but it is recommended that the flow is uphill.
- ② Avoid mounting the meter with the flow running downhill because it can cause siphoning. If the meter has to be mounted with the flow running downhill, install an orifice plate or control valve downstream of the meter to maintain backpressure.
- ③ Horizontal mounting with flow running left to right.
- ④ Avoid mounting meter with long vertical runs after the meter as it can cause cavitation. Where the installation includes a vertical run after the meter, install an orifice plate or control valve downstream to maintain backpressure.
- ⑤ The meter can be mounted vertically but it is recommended that the flow is uphill.
- ⑥ Avoid mounting the meter vertically with the flow running downhill. This can cause siphoning. If the meter has to be installed this way, install an orifice plate or control valve downstream to maintain backpressure.

### 3.4.3 Cross talk

Where more than one meter is being installed, a very high level of immunity to cross talk means that the meters can be mounted within close proximity to each other. The meters can be mounted either in series or parallel, as shown.

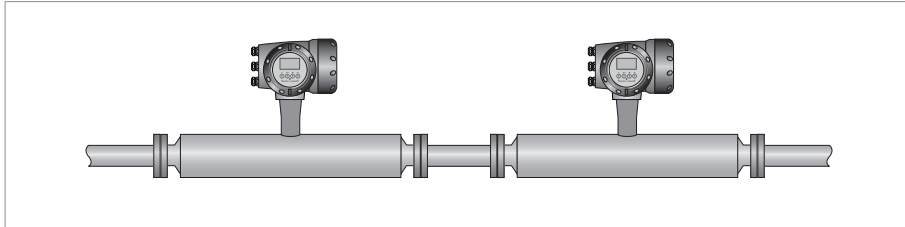

**INFORMATION!**

Where the meters are installed in series, it is strongly recommended that the process pipe diameter remains constant. For more information, please contact the manufacturer.

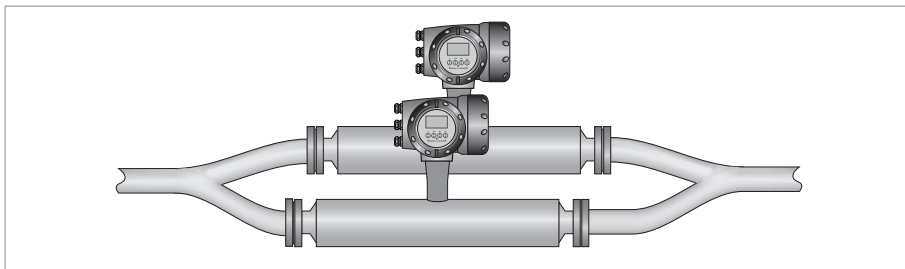

### 3.4.4 Flange connections

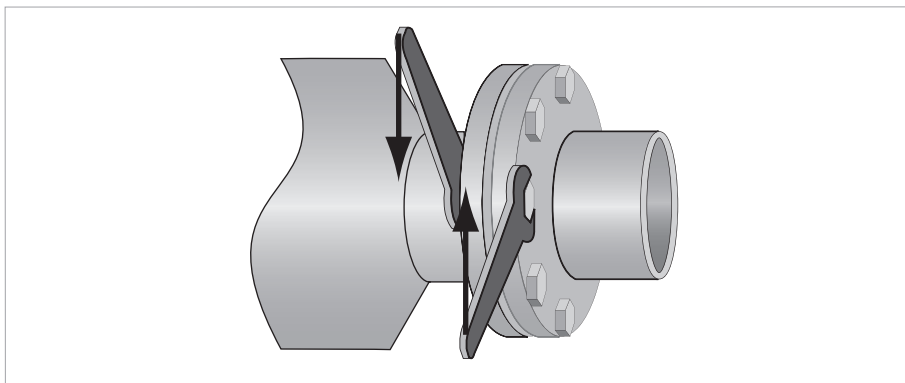

Tighten the flange bolts evenly and in turn.

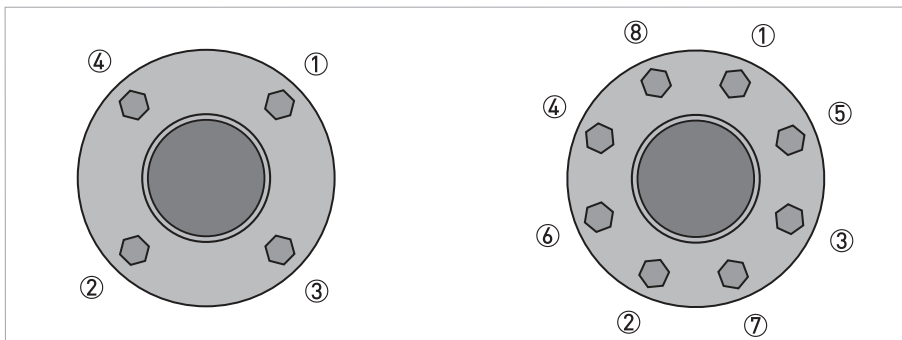

Use a regular pattern to tighten the bolts evenly

### 3.4.5 Maximum pipework forces (end loadings)

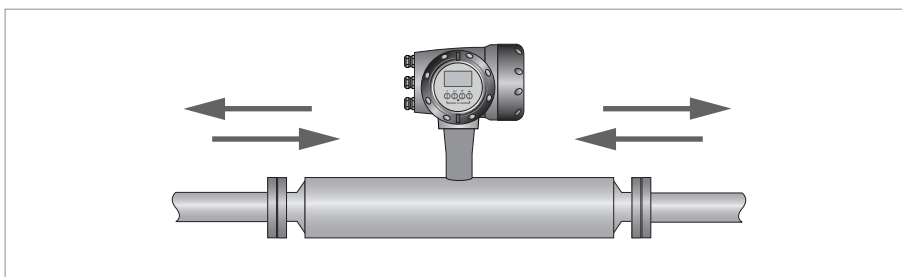

Mass flowmeters have a maximum level of force (negative or positive) that can be applied to the ends of the meter. Refer to the table below for permitted forces.

#### Maximum end loadings

		S15	S25	S40	S50
<b>Flanges</b>					
20°C	40 barg	25kN	38kN	48kN	99kN
	100 barg	17kN	19kN	15kN	20kN
130°C	32 barg	18kN	28kN	35kN	72kN
	80 barg	12kN	12kN	7kN	8kN
<b>Hygienic (all connections)</b>					
130°C	40 barg	3kN	5kN	N/A	N/A
	25 barg	N/A	N/A	9kN	N/A
	16 barg	N/A	N/A	N/A	9kN

- These (axial) loads have been calculated, based on 316L schedule 40 process pipework, where un-radiographed butt welds have been used in pipe joints.
- The loads shown are the maximum permitted static load. If loads are cycling (between tension and compression) these loads should be reduced. For advice, consult the manufacturer.

### 3.4.6 Pipework reducers

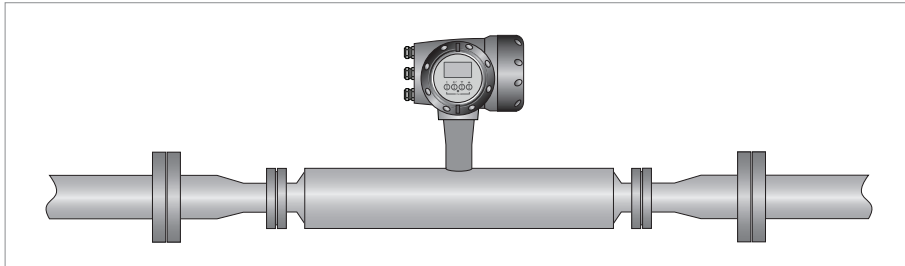

Always avoid extreme step changes in pipe size. Use pipework reducers, where there is a large difference between pipework size and meter flanges.

### 3.4.7 Flexible connections

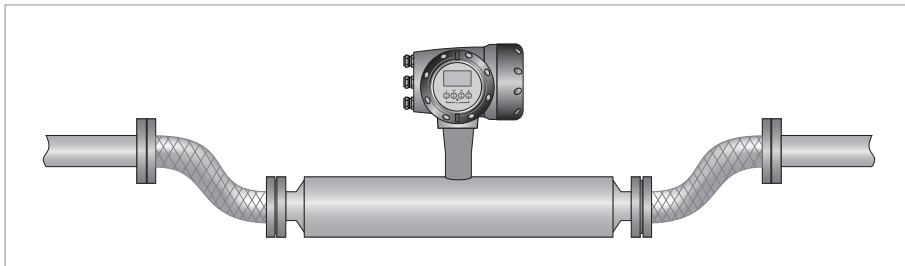

Flexible connections can be used but because of the high flow rates associated with large diameter meters, it is recommended that flexible connections are not used on meters larger than size 80.

### 3.4.8 Hygienic installations

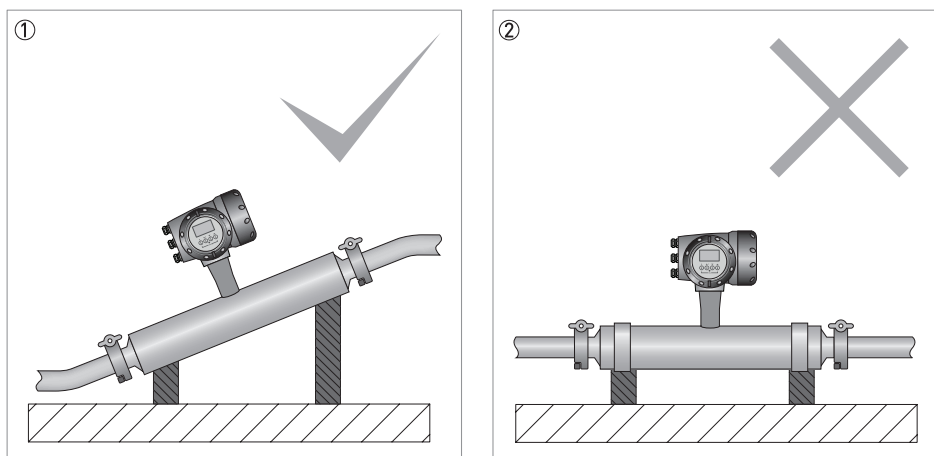

- ① Install the meter at an angle to allow self-draining.
- ② DO NOT install the meter horizontally.

Where the meter has been approved by the sanitary requirements of the European Hygienic Engineering and Design Group, you MUST give consideration to:

- Installation - install the meter at an angle to allow self-draining (see illustration).
- Cleaning fluids - cleaning fluids should flow uphill with a velocity rate greater than 1.5 m/s / 5ft/s. If the process flow is downhill, install a flow restrictor downstream of the meter. This will make sure that the meter is completely filled with the cleaning fluid.
- Process connections and seals MUST be in accordance with EHEDG documentation.

The manufacturer also recommends that you refer to EHEDG ([www.ehedg.org](http://www.ehedg.org)) document number 8 "HYGIENIC EQUIPMENT DESIGN CRITERIA".

### 3.4.9 Heating and insulation

#### Heating

The meter can be heated by electrical tape (or similar) as shown. ONLY heat the meter in the area marked A.

#### Insulation

The meter can also be insulated to a maximum depth as shown (B). Do not insulate above this depth as this will cause the electronics to overheat.

#### Electrical heating and insulation

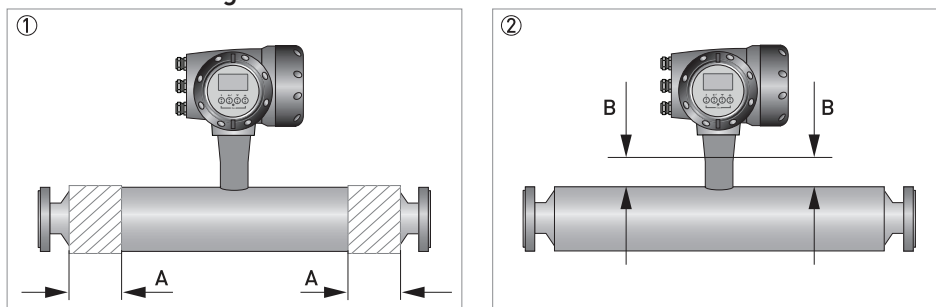

- ① Area that can be heated (A). Refer to the table for the maximum sizes.
- ② Maximum depth of insulation (B). Refer to the table.

#### Heated area

		15	25	40	50
Dimension of A	mm	65	75	110	125
	Inches	15	25	40	50
Dimension of B	mm	50			
	Inches	2.0			

### Factory fitted heating jacket

If the meter has been ordered with a heating jacket, it will be supplied with NPT, Ermeto or flange connections.

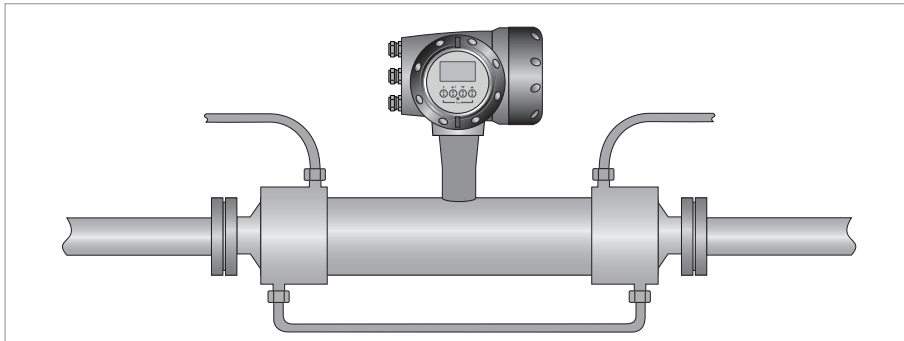

### Connecting / using the heating jacket

- Use reinforced flexible hoses to connect the heating jacket to the heat source.
- The heating jacket material is 316L but the heating medium is also in contact with the outer cylinder, which might be a lower grade stainless steel.
- Suitable heating mediums are steam or hot oil. Avoid the use of heating mediums that can cause crevice corrosion in Stainless Steel.
- Where liquid is being used, set up the pipe configuration so that air can be vented from the system.
- Where steam is being used, set up the pipe configuration so that condensation can be drained off.
- Heat the jacket to working temperature before flowing the process fluid through the meter.



#### **CAUTION!**

*The maximum heating pressure and temperature for heating jackets is 10 barg at 130°C / 145 psig at 266°F*

### Heating times

Temperature [°C / °F] ①	Time [minutes]			
	15	25	40	50
40 / 104			15	
60 / 140			45	
80 / 176			75	
100 / 212			135	
120 / 248			480	
① Measured at the centre of the measuring tube.				

## Reference conditions

Ambient temperature	+25°C / +77°F
Heating medium	Hot liquid
Heating medium temperature	+130°C / +266°F

## 3.4.10 Purge ports

If the meter has been ordered with a purge port, it will be supplied with NPT female connections which are clearly marked. The connections are sealed with NPT plugs and PTFE tape.

**CAUTION!**

*DO NOT remove these plugs.*

*The meter is factory sealed with a dry nitrogen gas fill and if moisture is allowed to enter the meter casing it will cause damage. The plugs should only be removed to purge the meter casing in the event that the primary measuring tube fails.*

*If it is suspected that the primary measuring tube has failed, de-pressurise the meter and remove it from service, as soon as it is safe to do so.*

## 3.4.11 Zero calibration

The procedure for zero calibration is contained in the converter handbook. However, the following information should be considered when installing the meter.

## Zero calibration

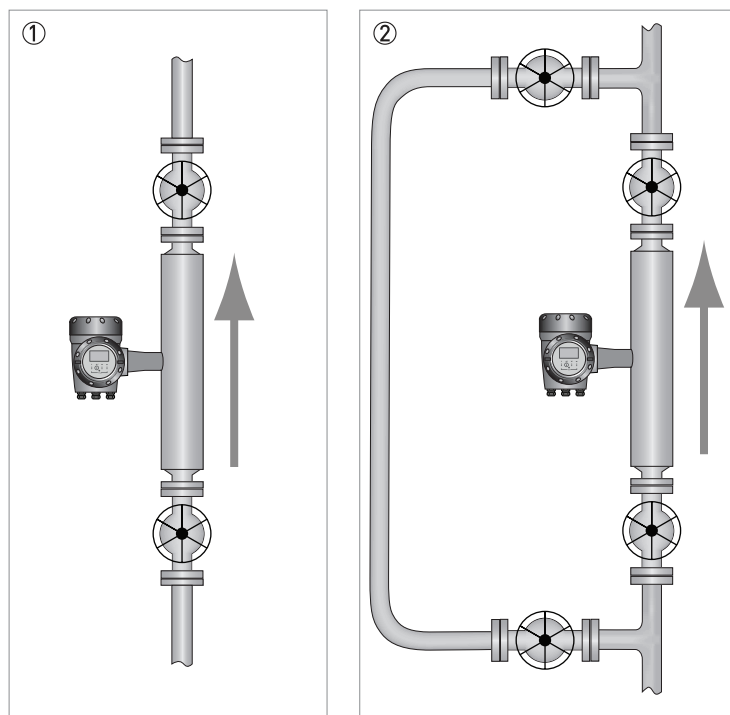

- ① Where the meter has been installed vertically, install shut-off valves either side of the meter to assist with zero calibration.
- ② If the process flow cannot be stopped, install a bypass section for zero calibration.



### 3.4.12 Sunshades

The meter **MUST** be protected from strong sunlight.

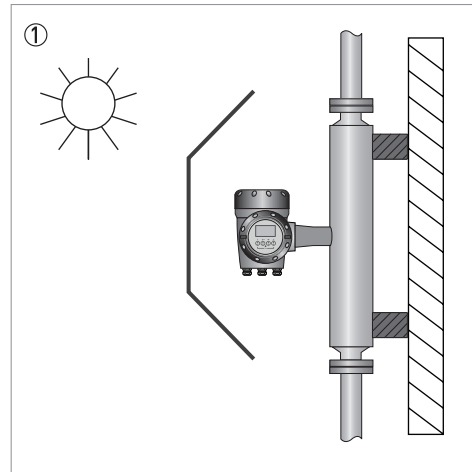
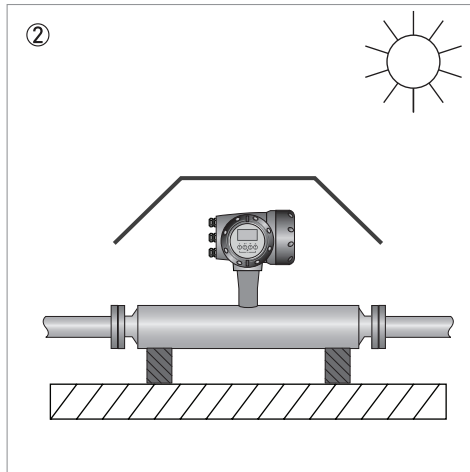

- ① Horizontal installation
- ② Vertical installation

## 4.1 Safety instructions

**DANGER!**

*All work on the electrical connections may only be carried out with the power disconnected.  
Take note of the voltage data on the nameplate!*

**DANGER!**

*Observe the national regulations for electrical installations!*

**DANGER!**

*For devices used in hazardous areas, additional safety notes apply; please refer to the Ex documentation.*

**WARNING!**

*Observe without fail the local occupational health and safety regulations.  
Any work done on the electrical components of the measuring device may only be carried out by properly trained specialists.*

**INFORMATION!**

*Look at the device nameplate to ensure that the device is delivered according to your order.  
Check for the correct supply voltage printed on the nameplate.*

## 4.2 Electrical and I/O connections

For information regarding electrical and I/O connections, please refer to the handbook for the relevant signal converter.

## 5.1 Spare parts availability

The manufacturer adheres to the basic principle that functionally adequate spare parts for each device or each important accessory part will be kept available for a period of 3 years after delivery of the last production run for the device.

This regulation only applies to spare parts which are subject to wear and tear under normal operating conditions.

## 5.2 Availability of services

The manufacturer offers a range of services to support the customer after expiration of the warranty. These include repair, maintenance, technical support and training.



### **INFORMATION!**

*For more precise information, please contact your local sales office.*

## 5.3 Returning the device to the manufacturer

### 5.3.1 General information

This device has been carefully manufactured and tested. If installed and operated in accordance with these operating instructions, it will rarely present any problems.



### **WARNING!**

*Should you nevertheless need to return a device for inspection or repair, please pay strict attention to the following points:*

- *Due to statutory regulations on environmental protection and safeguarding the health and safety of the personnel, the manufacturer may only handle, test and repair returned devices that have been in contact with products without risk to personnel and environment.*
- *This means that the manufacturer can only service this device if it is accompanied by the following certificate (see next section) confirming that the device is safe to handle.*



### **WARNING!**

*If the device has been operated with toxic, caustic, radioactive, flammable or water-endangering products, you are kindly requested:*

- *to check and ensure, if necessary by rinsing or neutralising, that all cavities are free from such dangerous substances,*
- *to enclose a certificate with the device confirming that it is safe to handle and stating the product used.*

### 5.3.2 Form (for copying) to accompany a returned device



**CAUTION!**

*To avoid any risk for our service personnel, this form has to be accessible from outside of the packaging with the returned device.*

Company:		Address:	
Department:		Name:	
Tel. no.:		Fax no. and/or Email address:	
Manufacturer's order no. or serial no.:			
The device has been operated with the following medium:			
This medium is:	<input type="checkbox"/>	radioactive	
	<input type="checkbox"/>	water-hazardous	
	<input type="checkbox"/>	toxic	
	<input type="checkbox"/>	caustic	
	<input type="checkbox"/>	flammable	
	<input type="checkbox"/>	We checked that all cavities in the device are free from such substances.	
	<input type="checkbox"/>	We have flushed out and neutralized all cavities in the device.	
We hereby confirm that there is no risk to persons or the environment through any residual media contained in the device when it is returned.			
Date:		Signature:	
Stamp:			

### 5.4 Disposal



**LEGAL NOTICE!**

*Disposal must be carried out in accordance with legislation applicable in your country.*

**Separate collection of WEEE (Waste Electrical and Electronic Equipment) in the European Union:**



According to the directive 2012/19/EU, the monitoring and control instruments marked with the WEEE symbol and reaching their end-of-life **must not be disposed of with other waste**.

The user must dispose of the WEEE to a designated collection point for the recycling of WEEE or send them back to our local organisation or authorised representative.

## 6.1 Measuring principle (twin tube)

Static meter not energised and with no flow

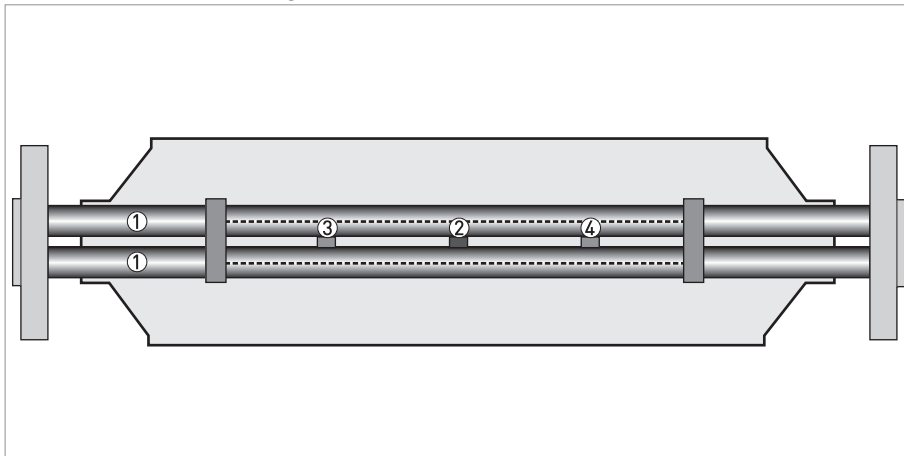

- ① Measuring tubes
- ② Drive coil
- ③ Sensor 1
- ④ Sensor 2

A Coriolis twin tube mass flowmeter consists of two measuring tubes ① a drive coil ② and two sensors (③ and ④) that are positioned either side of the drive coil.

Energised meter

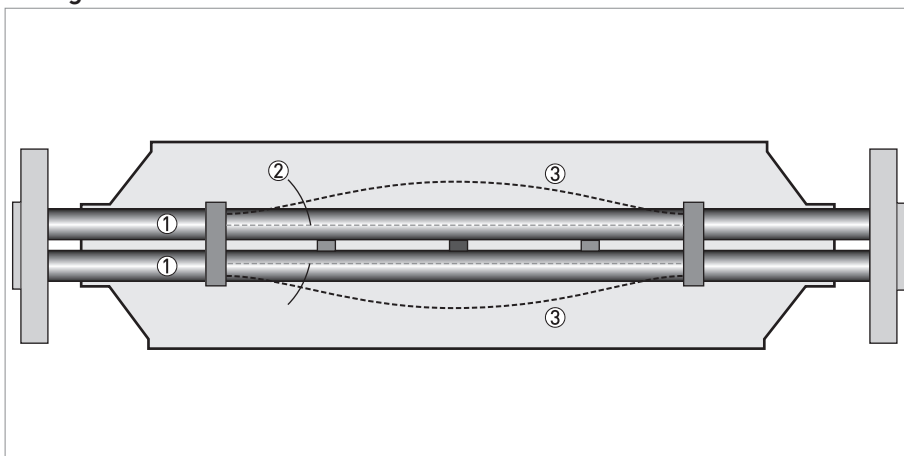

- ① Measuring tubes
- ② Direction of oscillation
- ③ Sine wave

When the meter is energised, the drive coil vibrates the measuring tubes causing them to oscillate and produce a sine wave ③. The sine wave is monitored by the two sensors.

## Energised meter with process flow

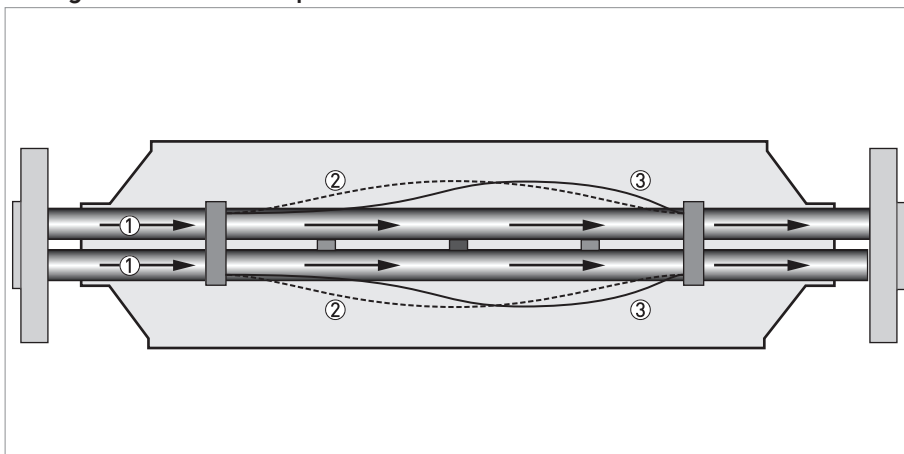

- ① Process flow
- ② Sine wave
- ③ Phase shift

When a fluid or gas passes through the tubes, the coriolis effect causes a phase shift in the sine wave that is detected by the two sensors. This phase shift is directly proportional to the mass flow.

Density measurement is made by evaluation of the frequency of vibration and temperature measurement is made using a Pt500 sensor.

## 6.2 Technical data



### INFORMATION!

- The following data is provided for general applications. If you require data that is more relevant to your specific application, please contact us or your local sales office.
- Additional information (certificates, special tools, software,...) and complete product documentation can be downloaded free of charge from the website (Downloadcenter).

### Measuring system

Measuring principle	Coriolis mass flow
Application range	Mass flow and density measurement of fluids, gases and solids
Measured values	Mass, density, temperature
Calculated values	Volume, referred density, concentration, velocity
<b>Sensor model range</b>	
Stainless Steel S31803 15...50	Compact / remote 100 barg @ 20°C / 1450 psig @ 68°F, temp. range -40°C...+130°C / --40°F...+266°F

### Design

Basic	System consists of a measuring sensor and a converter to process the output signal
Features	Fully welded maintenance free sensor with twin straight measuring tubes
<b>Variants</b>	
Compact version	Integral converter
Remote version	Available with a field version of the converter

### Performance specification

<b>Reference conditions</b>	
Calibration fluid	Water
Calibration temperature	+20°C / +68°F (± 5°C)
Calibration pressure	1...6 barg / 14.5...87 psig
Calibration rig	Accreditation satisfies the requirements of BS EN ISO / IEC 17025
<b>Mass flow</b>	
Liquid	
Base accuracy	±0.15% of actual measured flow rate ±zero stability
Repeatability	Better than 0.075% of actual measured flow rate ±zero stability
Gas	
Base accuracy	±0.5% of actual measured flow rate ±zero stability
Repeatability	Better than 0.2% of actual measured flow rate ±zero stability
<b>Zero stability</b>	
Meter size	
15	0.65 kg/h / 0.024 lb/min
25	2.70 kg/h / 0.099 lb/min
40	8.00 kg/h / 0.294 lb/min
50	17.00 kg/h / 0.625 lb/min

<b>Effect on sensor zero point caused by a deviation in process temperature from zero calibration temperature</b>	
All meter sizes	±0.0075% of nominal flow per 1°C / ±0.0042% of nominal flow per 1°F
<b>Effect on sensor zero point caused by a deviation in process pressure from zero calibration pressure</b>	
All meter sizes	+0.015% of nominal flow per 1 bar / +0.001% of nominal flow per 1 psi
<b>Density</b>	
Measuring range	400...2500 kg/m <sup>3</sup> / 25...155 lb/ft <sup>3</sup>
Measurement error	
S15	±5 kg/m <sup>3</sup> / ±0.33 lb/ft <sup>3</sup>
S25...50	±2 kg/m <sup>3</sup> / ±0.13 lb/ft <sup>3</sup>
Repeatability / on-site calibration	
S15	±2 kg/m <sup>3</sup> / ±0.13 lb/ft <sup>3</sup>
S25...50	±0.5 kg/m <sup>3</sup> / ±0.033 lb/ft <sup>3</sup>
<b>Process temperature effect of deviation from calibration temperature</b>	
S15	Better than ±0.25 g/l per 1°C / ±0.0156 lb/ft <sup>3</sup> per 1°F
S25...50	Better than ±0.15 g/l per 1°C / ±0.0094 lb/ft <sup>3</sup> per 1°F
<b>Volume flow</b>	
Measurement error and repeatability calculations satisfy the requirements of BS ISO 10790 (most recent and up to date version)	
<b>Temperature</b>	
Measurement error	±1°C / ± 1.8°F of reading

### Operating conditions

<b>Nominal flow rates</b> (1 barg / 14.5 psig pressure drop)	
Meter size	
15	4800 kg/h / 176.4 lb/min
25	20000 kg/h / 734.9 lb/min
40	60000 kg/h / 2204.6 lb/min
50	125000 kg/h / 4593 lb/min
<b>Maximum flow rates</b>	
All meters	130% of nominal flow rate

### Environmental

<b>Ambient temperature</b>	
Compact version with Aluminium converter	-40...+60°C / -40...+140°F
	Extended temperature range: +65°C / +149°F for some I/O options. For more information contact manufacturer.
Compact version with Stainless Steel converter	-40...+55°C / -40...+130°F
Remote versions	-40...+65°C / -40...+149°F
<b>Process temperature</b>	
Flanged connection	-40...+130°C / -40...+266°F
Hygienic connection	-40...+130°C / -40...+266°F
Hazardous Area versions	Refer to temperature limits
Protection category (Acc. to EN 60529)	IP 66 / 67, NEMA 4X
Vibration (acc IEC 60068-2-6)	10-150-10 Hz with 0.15 mm for 10...60 Hz, 20 m/s <sup>2</sup> for 60...150 Hz



<b>Process temperatures</b>	
Flanged connection	-40...+130°C / -40...+266°F
Hygienic connection	-40...+130°C / -40...+266°F
<b>Nominal pressure at 20°C / 68°F</b>	
<b>Measuring tube</b>	SS 316 / 316L
FM / PED	-1...100 barg / -14.5...1450 psig
CRN / ASME B31.3	-1...100 barg / -14.5...1450 psig
If the process temperature is higher than 20°C / 68°F, the burst pressure will be lower. For more information please contact the manufacturer.	
<b>Fluid properties</b>	
Permissible physical condition	Liquids, gases, slurries
Permissible gas content (volume)	Contact manufacturer for information.
Permissible solid content (volume)	Contact manufacturer for information.
<b>Installation conditions</b>	
Inlet / outlet runs	None required

## Materials

Measuring tubes	Stainless Steel UNS S31803 (1.4462)
Spigots	Stainless Steel 316 / 316L (CF3M / 1.4409) dual certified
Flanges	Stainless Steel 316 / 316L (1.4401 / 1.4404) dual certified
Outer cylinder	Stainless Steel 304 / 304L (1.4301 / 1.4307) dual certified
	Optional Stainless Steel 316 / 316L (1.4401 / 1.4404) dual certified
<b>Heating jacket version</b>	
Heating jacket	Stainless Steel 316L (1.4404)
	The outer cylinder is in contact with the heating medium
<b>All versions</b>	
Junction box (remote version)	Die cast Aluminium (polyurethane coating)
	Optional Stainless Steel 316 (1.4401)

## Process connections

<b>Flange</b>	
DIN	DN15...80 / PN40...100
ASME	½...3" / ASME 150...600
JIS	15...80A / 10...20K
<b>Hygienic</b>	
Tri-clover	1...3"
Tri-clamp DIN 32676	DN25...80
Tri-clamp ISO 2852	1...3"
DIN 11864-2 Form A	DN25...80
Male thread DIN 11851	DN25...80
Male thread SMS	1...3"

## Electrical connections

Electrical connections	For full details, including: power supply, power consumption etc., see technical data for the relevant signal converter.
I/O	For full details of I/O options, including data streams and protocols, see technical data for the relevant signal converter.

## Approvals

CE	The device fulfils the statutory requirements of the CE directive. The manufacturer certifies that these requirements have been met by applying the CE mark.
CRN	acc to: ASME B31.3 (most recent and up to date version)
NACE	MR0175 / ISO 15156 ("Sulphide Stress Corrosion Cracking Resistant Metallic Materials for Oil Field Equipment") and MR0103 ("Materials Resistant to Sulfide Stress Cracking in Corrosive Petroleum Refining Environments") (most recent and up to date versions)
<b>ATEX (most recent and up to date version)</b>	
<b>OPTIMASS 1400C non Ex i signal outputs without heating jacket / insulation</b>	
Ex d connection compartment	II 1/2 G Ex d ia IIC T6...T1 Ga/Gb
	II 2 D Ex tb IIIC T165°C Db
Ex e connection compartment	II 1/2 G Ex de ia IIC T6...T1 Ga/Gb
	II 2 D Ex tb IIIC T165°C Db
<b>OPTIMASS 1400C non Ex i signal outputs with heating jacket / insulation</b>	
Ex d connection compartment	II 1/2 G Ex d ia IIC T6...T1 Ga/Gb
	II 2 D Ex tb IIIC T165°C Db
Ex e connection compartment	II 1/2 G Ex de ia IIC T6...T1 Ga/Gb
	II 2 D Ex tb IIIC T165°C Db
<b>OPTIMASS 1400C Ex i signal outputs without heating jacket / insulation</b>	
Ex d connection compartment	I 1/2(1) G Ex d ia [ia Ga] IIC T6...T1 Ga/Gb
	II 2(1) D Ex tb [ia Da] IIIC T165°C Db
Ex e connection compartment	I 1/2(1) G Ex de ia [ia Ga] IIC T6...T1 G
	II 2(1) D Ex tb [ia Da] IIIC T165°C Db
<b>OPTIMASS 1400C Ex i signal outputs with heating jacket / insulation</b>	
Ex d connection compartment	I 1/2(1) G Ex d ia [ia Ga] IIC T6...T1 Ga/Gb
	II 2(1) D Ex tb [ia Da] IIIC T165°C Db
Ex e connection compartment	I 1/2(1) G Ex de ia [ia Ga] IIC T6...T1 G
	II 2(1) D Ex tb [ia Da] IIIC T165°C Db

### 6.3 ATEX temperature limits

Ambient temp. $T_{amb}$ °C	Medium temp. $T_m$ °C	Temp. class	Max. Surface temp. °C
OPTIMASS 1400C - with or without heating jacket / insulation			
40	40	T6	T75
	55	T5	T90
	90	T4	T125
	130	T3 - T1	T165
50	55	T5	T90
	90	T4	T125
	130	T3 - T1	T165
65	75	T4	T110
	130	T3 - T1	T165
OPTIMASS 1400C - aluminium converter housing - with or without heating jacket / insulation			
40	40	T6	T75
	55	T5	T90
	90	T4	T125
	130	T3 - T1	T165
50	55	T5	T90
	90	T4	T125
	130	T3 - T1	T165
65	65	T4 - T1	T100
OPTIMASS 1400C - SS converter housing - with or without heating jacket / insulation			
40	40	T6	T75
	55	T5	T90
	90	T4	T125
	130	T3 - T1	T165
50	55	T5	T90
	90	T4 - T1	T125
60	60	T5 - T1	T95

## 6.4 Maximum pipework forces (end loadings)

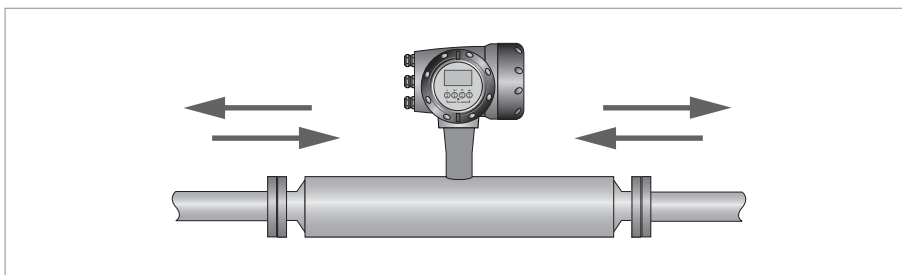

Mass flowmeters have a maximum level of force (negative or positive) that can be applied to the ends of the meter. Refer to the table below for permitted forces.

### Maximum end loadings

		S15	S25	S40	S50
<b>Flanges</b>					
20°C	40 barg	25kN	38kN	48kN	99kN
	100 barg	17kN	19kN	15kN	20kN
130°C	32 barg	18kN	28kN	35kN	72kN
	80 barg	12kN	12kN	7kN	8kN
<b>Hygienic (all connections)</b>					
130°C	40 barg	3kN	5kN	N/A	N/A
	25 barg	N/A	N/A	9kN	N/A
	16 barg	N/A	N/A	N/A	9kN

- These (axial) loads have been calculated, based on 316L schedule 40 process pipework, where un-radiographed butt welds have been used in pipe joints.
- The loads shown are the maximum permitted static load. If loads are cycling (between tension and compression) these loads should be reduced. For advice, consult the manufacturer.

## 6.5 Guidelines for maximum operating pressure

### Notes:

- Ensure that the meter is used within its operating limits
- All hygienic process connections have a maximum operating rating of 10 barg at 130°C / 145 psig at 266°F

### Pressure / temperature de-rating, all meter sizes, in metric (flanged connections as per EN 1092-1)

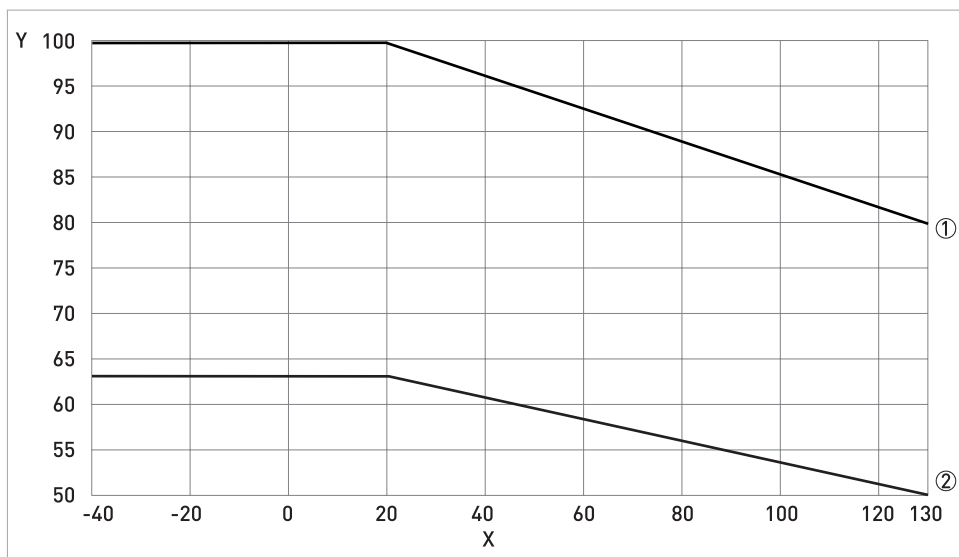

X temperature [°C]

Y pressure [barg]

- ① Measuring tubes and 100barg 316L secondary containment (PED)  
② 63 barg 304L / 316 secondary containment (PED)

### Pressure / temperature de-rating, all meter sizes, in imperial (flanged connections as per ASME B16.5)

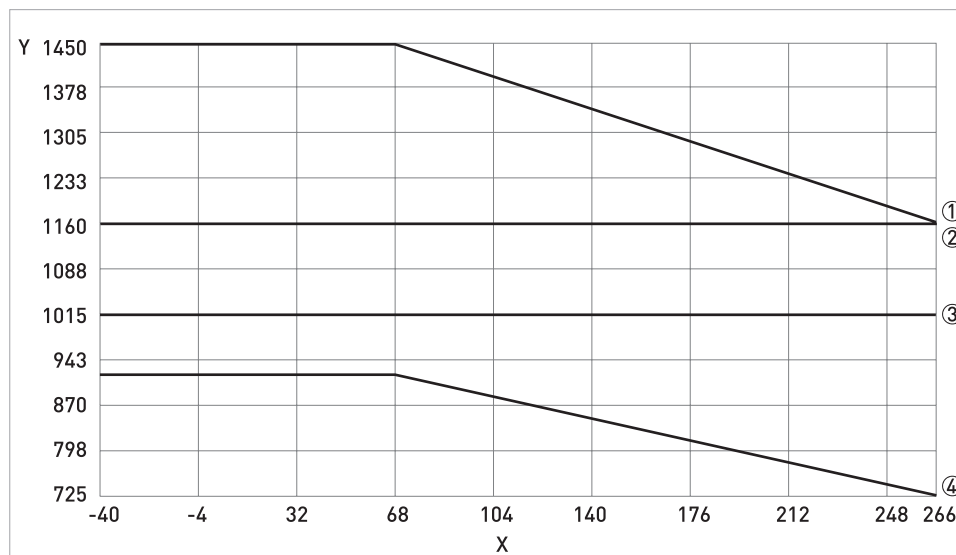

X temperature [°F]

Y pressure [psig]

- ① Measuring tubes S15 / S25 (CRN)
- ② Measuring tubes S40 (CRN)
- ③ Measuring tubes S50 (CRN)
- ④ Secondary containment 304L / 316L (CRN)

#### Flanges

- DIN flange ratings are based on EN 1092-1 2001 table 18 (1% proof stress) material group 14EO
- ASME flange ratings are based on ASME B16.5 2003 table 2 material group 2.2
- JIS flange ratings are based on JIS 2220: 2001 table 1 division 1 material group 022a

### Pressure / temperature de-rating (metric) for meters with hygienic connections.

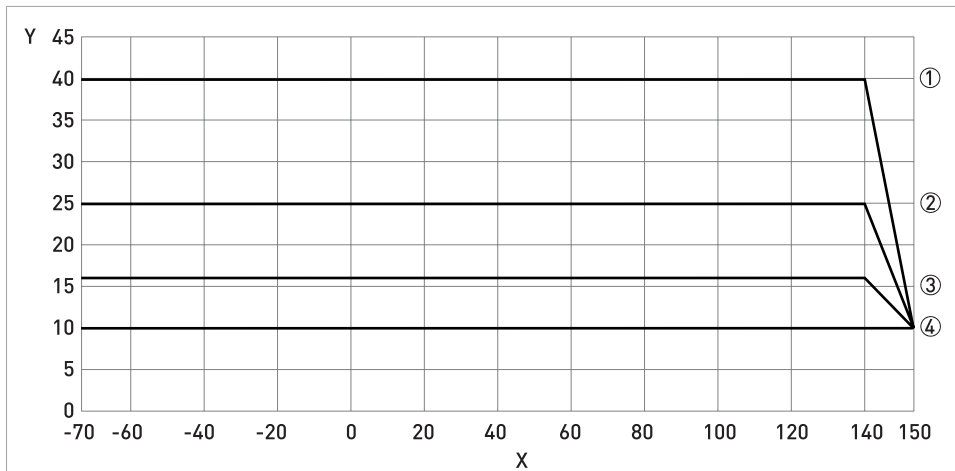

X temperature [°C]

Y pressure [barg]

- ① SMS 1...1½", DIN 11851 DN10...40
- ② SMS 2", Tri-clamp DN10...40, DIN 11864-2 DN10...40, DIN 11851 DN50...65
- ③ SMS 3", Tri-clamp DN50...65, DIN11864-2, DIN11864-2 DN50...100, DN11851 DN80...100
- ④ SMS 4", Tri-clamp DN80...100

### Pressure / temperature de-rating (imperial) for meters with hygienic connections.

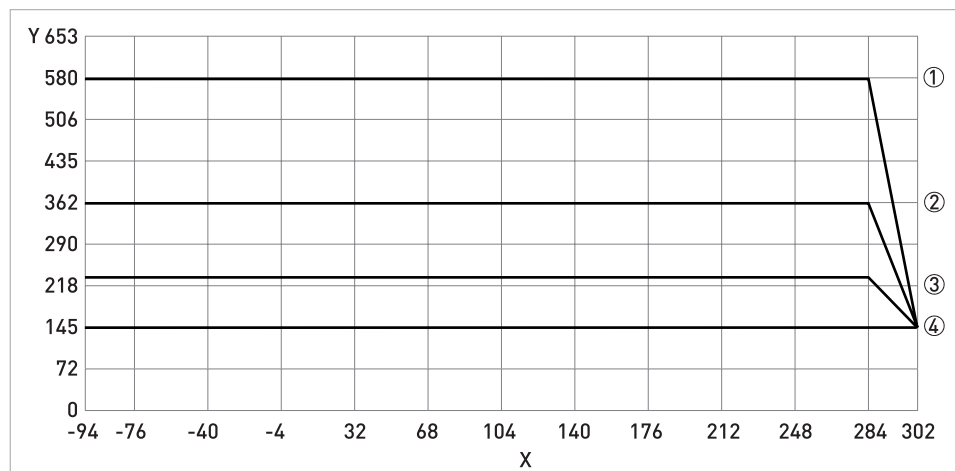

X temperature [°F]

Y pressure [psig]

- ① SMS 1...1½", DIN 11851 DN10...40
- ② SMS 2", Tri-clamp DN10...40, DIN 11864-2 DN10...40, DIN 11851 DN50...65
- ③ SMS 3", Tri-clamp DN50...65, DIN11864-2, DIN11864-2 DN50...100, DN11851 DN80...100
- ④ SMS 4", Tri-clamp DN80...100

### Notes

- The maximum operating pressure will be either the flange rating or the measuring tube rating, **WHICHEVER IS THE LOWER!**
- The manufacturer recommends that the seals are replaced at regular intervals. This will maintain the hygienic integrity of the connection.

## 6.6 Dimensions and weights

### 6.6.1 Flanged versions

#### Meter weights (all flanges)

	kg			
	S15	S25	S40	S50
Aluminium (compact)	13.5	16.5	29.5	57.5
Stainless Steel (compact)	18.8	21.8	34.8	62.8
Aluminium (remote)	11.5	14.5	25.5	51.5
Stainless Steel (remote)	12.4	15.4	26.4	52.4

	lbs			
	S15	S25	S40	S50
Aluminium (compact)	30	36.3	65	127
Stainless Steel (compact)	41	48	77	138
Aluminium (remote)	25	32	56	113
Stainless Steel (remote)	27	33.8	58	115

#### Meter dimensions

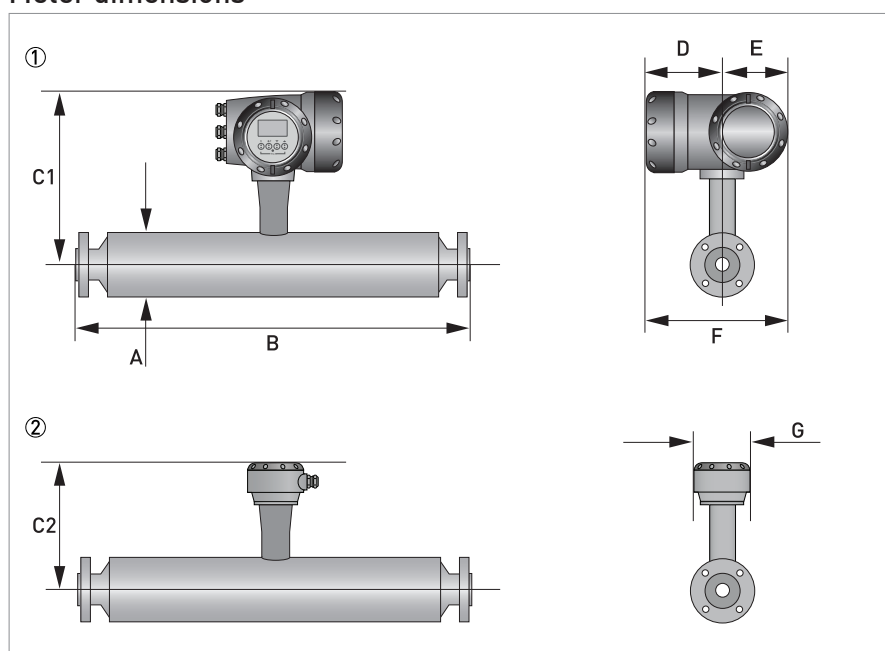

- ① Compact version
- ② Remote version



## General dimensions

	mm			
	S15	S25	S40	S50
A	101.6	114.3	168.3	219.1
C1 (compact)	311	317	344	370
C2 (remote)	231	237	264	290
D	137			
E	123.5			
F	260.5			
G	118			

	Inches			
	S15	S25	S40	S50
A	4	4.5	6.6	8.6
C1 (compact)	12.2	12.5	13.5	14.6
C2 (remote)	9	9.3	10.4	11.4
D	5.4			
E	4.9			
F	10.2			
G	4.6			

## Dimension B

	mm (±5)			
	S15	S25	S40	S50
<b>PN40</b>				
DN15	499	-	-	-
DN25	503	531	-	-
DN40	513	541	706	-
DN50	-	547	712	862
DN80	-	-	732	882
DN100	-	-	-	896
<b>PN63</b>				
DN50	-	-	740	890
DN80	-	-	-	910
<b>PN100</b>				
DN15	513	-	-	-
DN25	539	567	-	-
DN40	-	575	740	-
DN50	-	-	752	902
DN80	-	-	-	922

	mm ( $\pm 5$ )			
	S15	S25	S40	S50
<b>ASME 150 (Raised Face)</b>				
1/2"	519	-	-	-
3/4"	529	-	-	-
1"	535	563	-	-
1 1/2"	-	575	740	-
2"	-	579	744	894
3"	-	-	756	906
4"	-	-	-	920
<b>ASME 300 (Raised Face)</b>				
1/2"	529	-	-	-
3/4"	539	-	-	-
1"	547	575	-	-
1 1/2"	-	589	754	-
2"	-	-	756	906
3"	-	-	-	926
<b>ASME 600 (Raised Face)</b>				
1/2"	541	-	-	-
3/4"	551	-	-	-
1"	561	589	-	-
1 1/2"	-	605	770	-
2"	-	-	776	926
3"	-	-	-	946
<b>JIS 10K</b>				
50A	-	-	696	846
80A	-	-	-	856
<b>JIS 20K</b>				
15A	491	-	-	-
25A	499	527	-	-
40A	-	533	698	-
50A	-	-	700	850
80A	-	-	-	868

	Inches ( $\pm 0.2$ )			
	S15	S25	S40	S50
<b>PN40</b>				
DN15	19.6	-	-	-
DN25	19.8	21	-	-
DN40	20.2	21.3	27.8	-
DN50	-	21.5	28	33.9
DN80	-	-	28.8	34.7
DN100	-	-	-	35.3

	Inches (±0.2)			
	S15	S25	S40	S50
<b>PN63</b>				
DN50	-	-	29	35
DN80	-	-	-	35.8
<b>PN100</b>				
DN15	20.2	-	-	-
DN25	21.2	22.3	-	-
DN40	-	22.6	29	-
DN50	-	-	29.6	35.5
DN80	-	-	-	36.3
<b>ASME 150 (Raised Face)</b>				
½"	20.4	-	-	-
¾"	20.8	-	-	-
1"	21	22.2	-	-
1½"	-	22.5	29.1	-
2"	-	22.8	29.3	35.2
3"	-	-	29.8	35.7
4"	-	-	-	36.2
<b>ASME 300 (Raised Face)</b>				
½"	20.8	-	-	-
¾"	21.2	-	-	-
1"	21.5	22.6	-	-
1½"	-	23.2	29.7	-
2"	-	-	29.8	35.7
3"	-	-	-	36.4
<b>ASME 600 (Raised Face)</b>				
½"	21.3	-	-	-
¾"	21.6	-	-	-
1"	22	23.2	-	-
1½"	-	23.8	30.3	-
2"	-	-	30.5	36.4
3"	-	-	-	37.2
<b>JIS 10K</b>				
50A	-	-	27.4	33.3
80A	-	-	-	33.7
<b>JIS 20K</b>				
15A	19.3	-	-	-
25A	19.6	20.7	-	-
40A	-	21	27.5	-
50A	-	-	27.6	33.5
80A	-	-	-	34.2

## 6.6.2 NAMUR dimensions

The following face to face dimensions comply with NAMUR NE132

	mm ( $\pm 3$ )			
	S15	S25	S40	S50
<b>PN40</b>				
DN15	510	-	-	-
DN25	-	600	-	-
DN40	-	-	715	-
DN80	-	-	-	915

	Inches ( $\pm 0.12$ )			
	S15	S25	S40	S50
<b>PN40</b>				
DN15	20.1	-	-	-
DN25	-	23.6	-	-
DN40	-	-	28.1	-
DN80	-	-	-	36.0

### 6.6.3 Hygienic versions

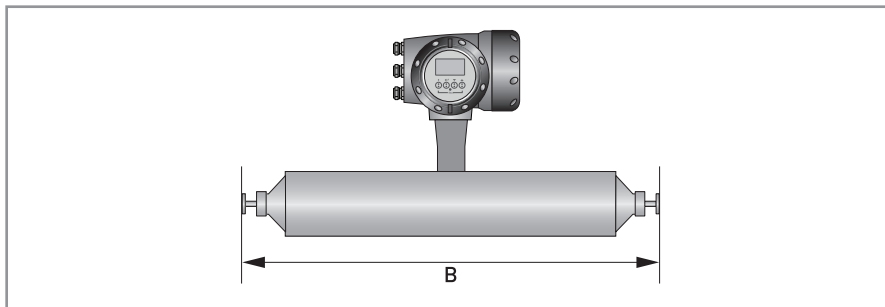

#### Dimension B: clamp versions

	mm (±5)			
	S15	S25	S40	S50
<b>Tri-clover</b>				
1"	488	-	-	-
1½"	-	534	-	-
2"	-	-	691	-
3"	-	-	-	832
<b>Tri-clamp DIN 32676</b>				
DN10	-	-	-	-
DN15	-	-	-	-
DN25	468	-	-	-
DN40	-	515	-	-
DN50	-	-	677	-
DN80	-	-	-	836
<b>Tri-clamp ISO 2852</b>				
1"	474	-	-	-
1½"	-	502	-	-
2"	-	-	667	-
3"	-	-	-	817
<b>DIN 11864-2 form A</b>				
DN25	505	-	-	-
DN40	-	562	-	-
DN50	-	-	724	-
DN80	-	-	-	896

	Inches ( $\pm 0.2$ )			
	S15	S25	S40	S50
<b>Tri-clover</b>				
1"	19.2	-	-	-
1½"	-	21	-	-
2"	-	-	27.2	-
3"	-	-	-	32.7
<b>Tri-clamp DIN 32676</b>				
DN10	-	-	-	-
DN15	-	-	-	-
DN25	18.4	-	-	-
DN40	-	20.3	-	-
DN50	-	-	26.6	-
DN80	-	-	-	32.9
<b>Tri-clamp ISO 2852</b>				
1"	18.6	-	-	-
1½"	-	19.8	-	-
2"	-	-	26.3	-
3"	-	-	-	32.2
<b>DIN 11864-2 form A</b>				
DN25	19.9	-	-	-
DN40	-	22.2	-	-
DN50	-	-	28.5	-
DN80	-	-	-	35.3

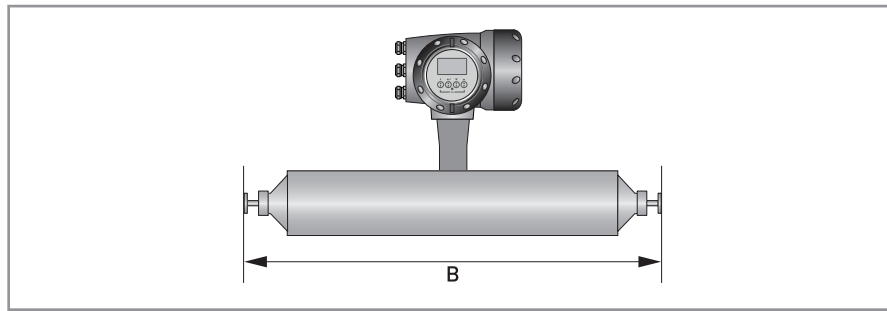

### Dimension B: adapter versions (male thread)

	mm (±5)			
	S15	S25	S40	S50
<b>Male thread DIN 11851</b>				
DN25	483	-	-	-
DN40	-	538	-	-
DN50	-	-	704	-
DN80	-	-	-	870
<b>Male thread SMS</b>				
1"	475	-	-	-
1½"	-	537	-	-
2"	-	-	694	-
3"	-	-	-	837
<b>Male thread IDF/ISS</b>				
1"	487	-	-	-
1½"	-	534	-	-
2"	-	-	691	-
3"	-	-	-	832
<b>Male thread RJT</b>				
1"	498	-	-	-
1½"	-	545	-	-
2"	-	-	702	-
3"	-	-	-	843

	Inches (±5)			
	S15	S25	S40	S50
<b>Male thread DIN 11851</b>				
DN25	19	-	-	-
DN40	-	21.2	-	-
DN50	-	-	27.7	-
DN80	-	-	-	34.2
<b>Male thread SMS</b>				
1"	18.7	-	-	-
1½"	-	21.1	-	-
2"	-	-	27.3	-
3"	-	-	-	32.9
<b>Male thread IDF/ISS</b>				
1"	19.2	-	-	-
1½"	-	21	-	-
2"	-	-	27.2	-
3"	-	-	-	32.7
<b>Male thread RJT</b>				
1"	19.6	-	-	-
1½"	-	21.4	-	-
2"	-	-	27.6	-
3"	-	-	-	33.2



## 6.6.4 Heating jacket version

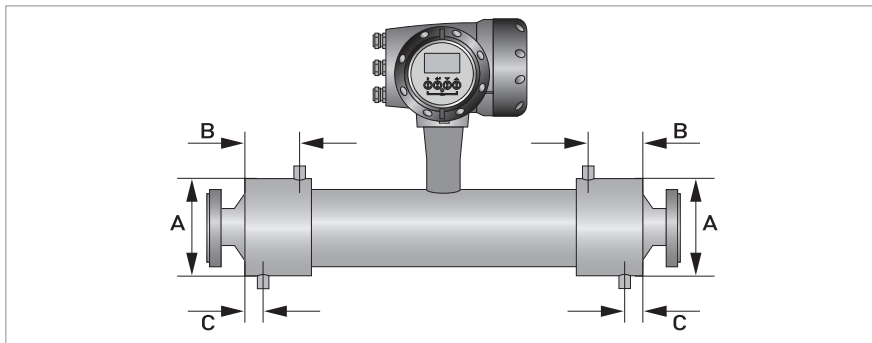

	Dimensions [mm]			
	S15	S25	S40	S50
Heating connection size	12 mm (ERMETO)			25
A	115 ±1	142 ±1	206 ±1	254 ±1
B	51	55	90	105
C	20			26

	Dimensions [inches]			
	S15	S25	S40	S50
Heating connection size	½" (NPTF)			1
A	4.5 ±0.04	5.6 ±0.04	8.1 ±0.04	10 ±0.04
B	2.0	2.2	3.5	4.1
C	0.8			1.0

6.6.5 Purge port option

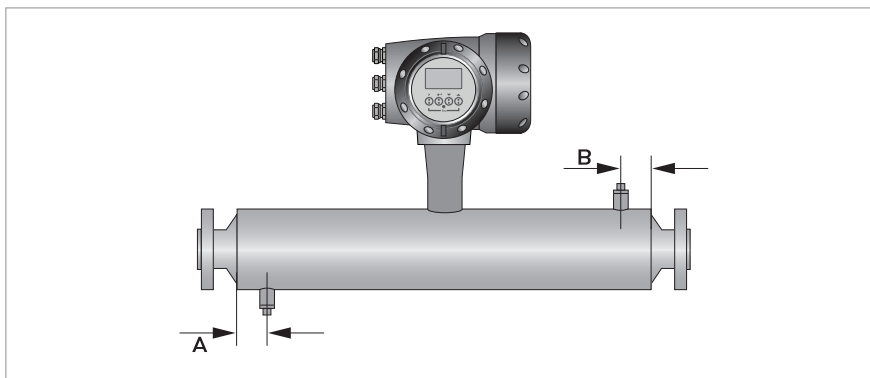

	Dimensions [mm]			
	S15	S25	S40	S50
A	55 ±1.0		65 ±1.0	
B	55 ±1.0		65 ±1.0	

	Dimensions [inches]			
	S15	S25	S40	S50
A	2.2 ±0.04		2.5 ±0.04	
B	2.2 ±0.04		2.5 ±0.04	





## KROHNE – Process instrumentation and measurement solutions

- Flow
- Level
- Temperature
- Pressure
- Process Analysis
- Services

Head Office KROHNE Messtechnik GmbH  
Ludwig-Krohne-Str. 5  
47058 Duisburg (Germany)  
Tel.: +49 203 301 0  
Fax: +49 203 301 10389  
info@krohne.com

The current list of all KROHNE contacts and addresses can be found at:  
[www.krohne.com](http://www.krohne.com)

**KROHNE**