



## OPTISENS ORP 8500 Handbook

ORP sensor

The documentation is only complete when used in combination with the relevant documentation for the signal converter.

All rights reserved. It is prohibited to reproduce this documentation, or any part thereof, without the prior written authorisation of KROHNE Messtechnik GmbH.

Subject to change without notice.

Copyright 2016 by  
KROHNE Messtechnik GmbH - Ludwig-Krohne-Str. 5 - 47058 Duisburg (Germany)

1	Safety instructions	5
1.1	Intended use	5
1.2	Safety instructions from the manufacturer	5
1.2.1	Copyright and data protection	5
1.2.2	Disclaimer	6
1.2.3	Product liability and warranty	6
1.2.4	Information concerning the documentation	6
1.2.5	Warnings and symbols used	7
1.3	Safety instructions for the operator	7
2	Device description	8
2.1	Scope of delivery	8
2.2	Device description	9
2.2.1	ORP sensor	9
2.3	Nameplate	9
3	Installation	10
3.1	General notes on installation	10
3.2	Storage and transport	10
3.3	Installation procedure	11
3.4	Pre-installation requirements	12
3.5	Calibrating the sensor	12
3.6	Installing the sensor	13
3.6.1	Installation instructions	13
3.6.2	Mounting to a flow-through assembly	13
3.6.3	Mounting to SENSOFIT IMM 1000 immersion assembly	15
3.7	Examples of a typical measuring point	17
4	Electrical connections	18
4.1	Safety instructions	18
4.1.1	Connecting the sensor cable to the signal converter	19
4.1.2	Connecting the external temperature sensor	20
4.1.3	Connecting the cable to the sensor	21
5	Operation	22
5.1	Menu mode structure	22
5.2	Function tables	24
5.2.1	Menu A, quick setup	24
5.2.2	Menu B, test	25
5.2.3	Menu C, setup	25
5.3	Calibration	27
5.3.1	Calibrating ORP measurement	27
5.3.2	Calibration log	30
5.4	Troubleshooting	31

6 Service	32
<hr/>	
6.1 Maintenance .....	32
6.1.1 Cleaning .....	32
6.1.2 Aging and re-calibration .....	32
6.2 Spare parts availability .....	32
6.3 Availability of services .....	32
6.4 Returning the device to the manufacturer .....	33
6.4.1 General information .....	33
6.4.2 Form (for copying) to accompany a returned device .....	34
6.5 Disposal .....	34
7 Technical data	35
<hr/>	
7.1 Measuring principle .....	35
7.1.1 ORP measurement .....	35
7.2 Technical data .....	36
7.3 Dimensions .....	38

## 1.1 Intended use

**CAUTION!**

*Responsibility for the use of the measuring devices with regard to suitability, intended use and corrosion resistance of the used materials against the measured fluid lies solely with the operator.*

**INFORMATION!**

*The manufacturer is not liable for any damage resulting from improper use or use for other than the intended purpose.*

The intended use of OPTISENS ORP 8500 sensor is the measurement of ORP in water. The sensor is suitable for connection to the MAC 100 signal converter.

## 1.2 Safety instructions from the manufacturer

### 1.2.1 Copyright and data protection

The contents of this document have been created with great care. Nevertheless, we provide no guarantee that the contents are correct, complete or up-to-date.

The contents and works in this document are subject to copyright. Contributions from third parties are identified as such. Reproduction, processing, dissemination and any type of use beyond what is permitted under copyright requires written authorisation from the respective author and/or the manufacturer.

The manufacturer tries always to observe the copyrights of others, and to draw on works created in-house or works in the public domain.

The collection of personal data (such as names, street addresses or e-mail addresses) in the manufacturer's documents is always on a voluntary basis whenever possible. Whenever feasible, it is always possible to make use of the offerings and services without providing any personal data.

We draw your attention to the fact that data transmission over the Internet (e.g. when communicating by e-mail) may involve gaps in security. It is not possible to protect such data completely against access by third parties.

We hereby expressly prohibit the use of the contact data published as part of our duty to publish an imprint for the purpose of sending us any advertising or informational materials that we have not expressly requested.

## 1.2.2 Disclaimer

The manufacturer will not be liable for any damage of any kind by using its product, including, but not limited to direct, indirect or incidental and consequential damages.

This disclaimer does not apply in case the manufacturer has acted on purpose or with gross negligence. In the event any applicable law does not allow such limitations on implied warranties or the exclusion of limitation of certain damages, you may, if such law applies to you, not be subject to some or all of the above disclaimer, exclusions or limitations.

Any product purchased from the manufacturer is warranted in accordance with the relevant product documentation and our Terms and Conditions of Sale.

The manufacturer reserves the right to alter the content of its documents, including this disclaimer in any way, at any time, for any reason, without prior notification, and will not be liable in any way for possible consequences of such changes.

## 1.2.3 Product liability and warranty

The operator shall bear responsibility for the suitability of the device for the specific purpose. The manufacturer accepts no liability for the consequences of misuse by the operator. Improper installation or operation of the devices (systems) will cause the warranty to be void. The respective "Standard Terms and Conditions" which form the basis for the sales contract shall also apply.

## 1.2.4 Information concerning the documentation

To prevent any injury to the user or damage to the device it is essential that you read the information in this document and observe applicable national standards, safety requirements and accident prevention regulations.

If this document is not in your native language and if you have any problems understanding the text, we advise you to contact your local office for assistance. The manufacturer can not accept responsibility for any damage or injury caused by misunderstanding of the information in this document.

This document is provided to help you establish operating conditions, which will permit safe and efficient use of this device. Special considerations and precautions are also described in the document, which appear in the form of icons as shown below.

### 1.2.5 Warnings and symbols used

Safety warnings are indicated by the following symbols.



**DANGER!**

*This warning refers to the immediate danger when working with electricity.*



**DANGER!**

*This warning refers to the immediate danger of burns caused by heat or hot surfaces.*



**DANGER!**

*This warning refers to the immediate danger when using this device in a hazardous atmosphere.*



**DANGER!**

*These warnings must be observed without fail. Even partial disregard of this warning can lead to serious health problems and even death. There is also the risk of seriously damaging the device or parts of the operator's plant.*



**WARNING!**

*Disregarding this safety warning, even if only in part, poses the risk of serious health problems. There is also the risk of damaging the device or parts of the operator's plant.*



**CAUTION!**

*Disregarding these instructions can result in damage to the device or to parts of the operator's plant.*



**INFORMATION!**

*These instructions contain important information for the handling of the device.*



**LEGAL NOTICE!**

*This note contains information on statutory directives and standards.*



• **HANDLING**

This symbol designates all instructions for actions to be carried out by the operator in the specified sequence.

➔ **RESULT**

This symbol refers to all important consequences of the previous actions.

## 1.3 Safety instructions for the operator



**WARNING!**

*In general, devices from the manufacturer may only be installed, commissioned, operated and maintained by properly trained and authorized personnel.  
This document is provided to help you establish operating conditions, which will permit safe and efficient use of this device.*

## 2.1 Scope of delivery

**INFORMATION!**

Inspect the packaging carefully for damages or signs of rough handling. Report damage to the carrier and to the local office of the manufacturer.

**INFORMATION!**

Do a check of the packing list to make sure that you have all the elements given in the order.

**INFORMATION!**

Look at the device nameplate to ensure that the device is delivered according to your order. Check for the correct supply voltage printed on the nameplate.



Figure 2-1: Standard scope of delivery

- ① Ordered sensor
- ② Documentation

### Optional accessories

- SENSOFIT FLOW 1000 series - Flow-through assemblies
- SENSOFIT IMM 1000 / 2000 series - Immersion assemblies
- SENSOFIT INS 1000 / 7000 series - Insertion assemblies
- SENSOFIT RET / RAM 5000 series - Manual and pneumatic retractable assemblies
- Cable pH/ORP-W Sensor Coax 5 m / 16.5 ft
- Cable pH/ORP-W Sensor Coax 10 m / 33 ft

### Consumables/Spare parts available

- Various ORP solutions for sensor verification
- Various cleaning solutions

**INFORMATION!**

For further Information contact your local sales office.



## 2.2 Device description

### 2.2.1 ORP sensor

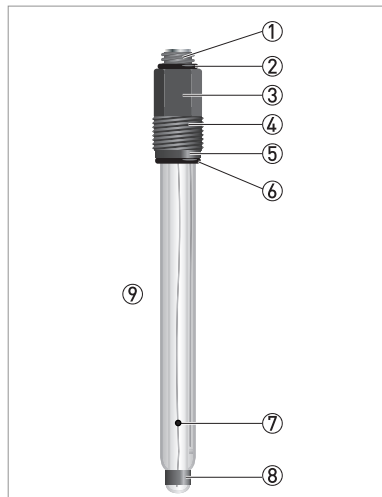

- ① Thread for sensor cable connector
- ② O-Ring
- ③ Hexagonal nut
- ④ Thread
- ⑤ Washer
- ⑥ O-Ring
- ⑦ Diaphragm
- ⑧ Pt-Ring
- ⑨ OPTISENS ORP 8500

## 2.3 Nameplate



### **INFORMATION!**

*Look at the device nameplate to ensure that the device is delivered according to your order.*

The sensor type is specified on the labelling of the sensor package and on the sensor itself.

### 3.1 General notes on installation

**INFORMATION!**

*Inspect the packaging carefully for damages or signs of rough handling. Report damage to the carrier and to the local office of the manufacturer.*

**INFORMATION!**

*Do a check of the packing list to make sure that you have all the elements given in the order.*

**INFORMATION!**

*Look at the device nameplate to ensure that the device is delivered according to your order. Check for the correct supply voltage printed on the nameplate.*

### 3.2 Storage and transport

**CAUTION!**

*Do not store the sensor tip dry. This will shorten lifetime considerably. Always store the ORP sensor tip wet in a 3 molar KCl solution when not in use. Saltless water must be avoided since this would leak the KCl ions. The original packing in which the sensor tip was delivered contains a plastic tube with KCl solution and therefore is suitable for storage and transport (see following drawing).*

- Since the ORP sensor is made out of glass it is very fragile. Avoid shocks of any kind.
- Do not touch or scratch the ORP sensitive platinum surface of the sensor.
- Store the sensor in its original packaging in a dry, dust-free location. Keep it away from dirt. If necessary, clean it as described on page 32.

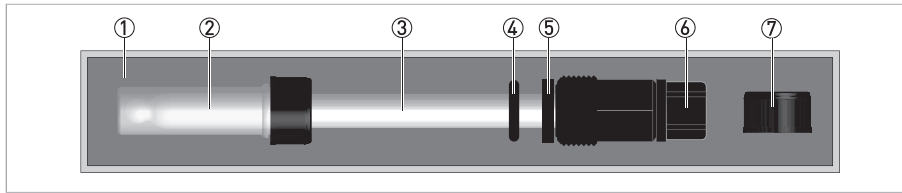

Figure 3-1: sensor in its original packaging

- ① Padding
- ② Plastic tube filled with 3 molar KCl solution
- ③ sensor
- ④ O-ring
- ⑤ Washer
- ⑥ Protective cap over electrical connector
- ⑦ Sealing cap without hole to seal plastic tube ② when sensor is in use



### Storing the sensor in the provided plastic tube

- Screw the sealing cap off the plastic tube. Keep it in the original packaging.
- If there is not enough KCl solution in the plastic tube, fill it up with 3 molar KCl solution.
- Insert the sensor tip through the hole in the storage cap (see drawing on page 12).
- Carefully push the O-ring delivered with the storage cap on the sensor so that the cap sits over the O-ring.
- Insert the sensor tip into the plastic tube until it is fully covered with KCl solution.
- Tighten the cap.
- Store the sensor in its original packaging.

## 3.3 Installation procedure

Because a new ORP sensor needs to be calibrated before it is installed into its final measuring location, it is important to follow the installation order:

1. Unpack the sensor.
2. Connect the sensor to the signal converter.
3. Calibrate the sensor.
4. Install the sensor into its final measuring location.

The required steps are explained in the following sections.

### 3.4 Pre-installation requirements



**CAUTION!**

- Do not drop the device! Handle the device with care!
- Never touch or scratch the platinum electrode of the sensor.
- Store the sensor in its original packaging in a dry, dust-free location. Keep it away from dirt. If necessary, clean it. See cleaning procedure on page 32.
- Do not make any mechanical modifications to the sensor (electrodes shortened, drilled, bent or scratched). This can result in the loss of proper functionality, as well as the rights under the device warranty.
- The sensor must be suitable for the temperature, pressure and medium conditions which are specified (including chemical resistance).

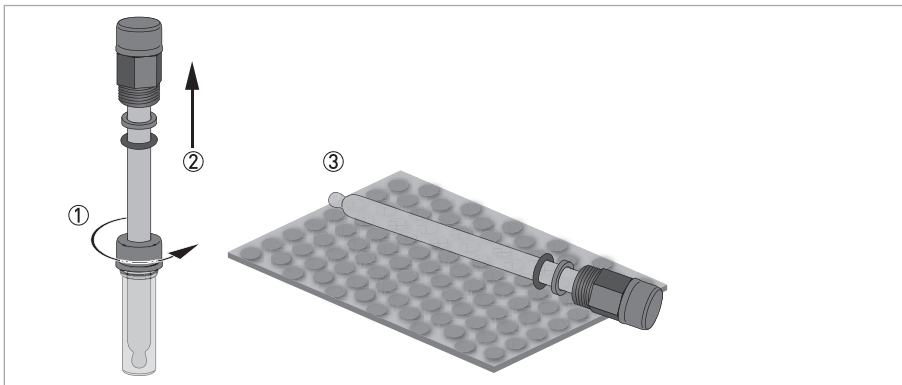

Figure 3-2: Handling the sensor



#### Unpacking the sensor

- Loosen the storage cap which is screwed or/and pushed on to the plastic tube ①.
- Gently pull the sensor out of the plastic tube ②.
- Lay the sensor on a soft mat/tissue ③.

### 3.5 Calibrating the sensor

Before the sensor is installed, it has to be calibrated. Proceed as described on page 27. Then continue with the installation procedure.

## 3.6 Installing the sensor

### 3.6.1 Installation instructions

The platinum electrode must always have full contact with the measuring medium.

The mounting position of the sensor should not deviate more than 75° from vertical position (sensor tip pointing downwards). Doing otherwise might cause internal air bubbles to float into the platinum electrode. This would interrupt the electrical contact between the inner buffer solution and the platinum surface.

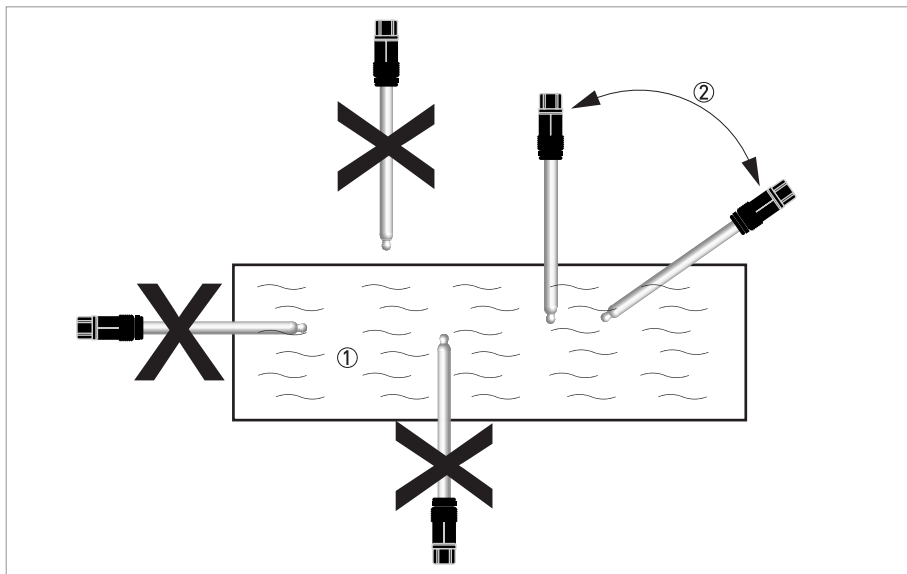

Figure 3-3: Installation requirements

- ① Measuring medium
- ② Maximum deviation of 75° from vertical position

### 3.6.2 Mounting to a flow-through assembly



**WARNING!**

*Ensure that the pipe is without pressure before installing or removing a sensor!*



**INFORMATION!**

*The flow-through assembly is an optional accessory and not part of the standard scope of delivery. It has to be installed horizontally in pump or sample lines or directly in the process.*

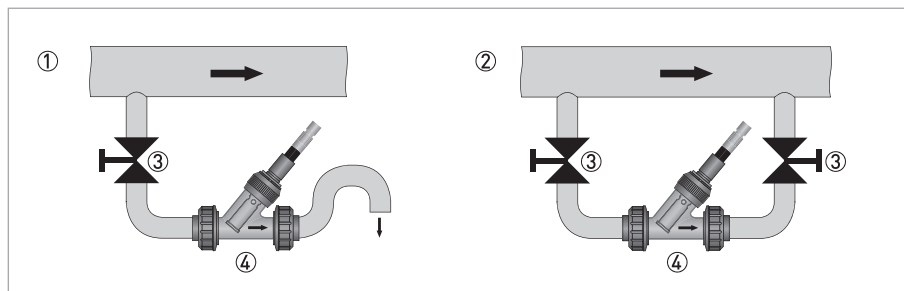

Figure 3-4: Possible mounting positions of the flow-through assembly

- ① Mounting in an outlet pipe
- ② Mounting in a bypass pipe
- ③ Valve
- ④ Flow-through assembly

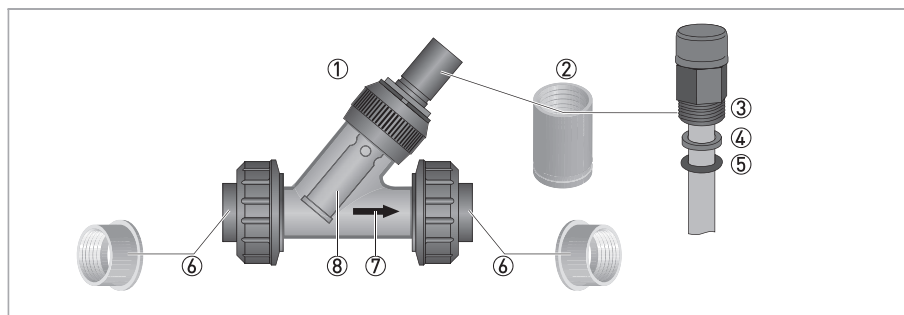

Figure 3-5: Installing the sensor into the flow-through assembly

- ① Flow-through assembly
- ② Female thread
- ③ Sensor thread
- ④ Washer
- ⑤ O-ring
- ⑥ Process connection
- ⑦ Flow direction
- ⑧ Protective cage



### Installing a new sensor

- Make sure that the O-ring ⑤ and the washer ④ on the sensor are assembled in the sequence indicated in the drawing.
- Screw the sensor into the female thread ② of the flow-through assembly ①. Tighten the sensor by hand.
- If you have not yet established the electrical connection to the signal converter, leave the protective cap on the sensor until you establish the electrical connection.

### 3.6.3 Mounting to SENSOFIT IMM 1000 immersion assembly



**CAUTION!**

- Never touch or scratch the platinum measuring tip of the ORP sensor.
- Make sure that the glass tip is clean and dust-free. If necessary, clean the tip as described in the manual of the sensor.



**INFORMATION!**

The immersion assembly is an optional accessory and not part of the standard scope of delivery.

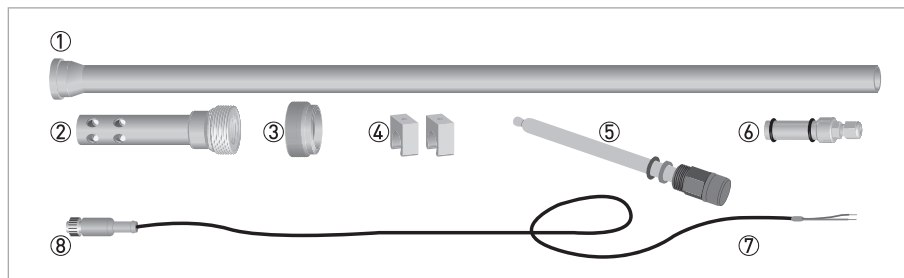

Figure 3-6: Overview of the immersion assembly

- ① Immersion assembly
- ② Protective cage
- ③ Union nut
- ④ Clamps
- ⑤ Sensor
- ⑥ Cap with cable gland
- ⑦ Sensor cable
- ⑧ Sensor connector



**CAUTION!**

Moisture on the sensor connector must be avoided! Moisture may cause a short-circuit and a malfunction of the sensor!

If moisture has entered the connector dry it with air (e.g. hot air gun).

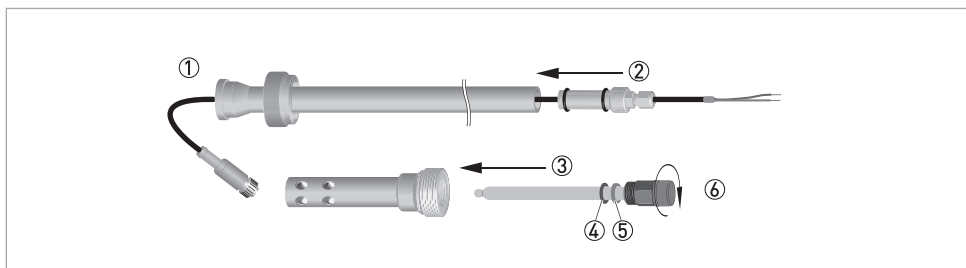

Figure 3-7: Installing a new sensor (step 1)



### Installing a new sensor (step 1)

- Pull the cap off the immersion assembly (upper part with cable gland).
- Unscrew the protective cage from the immersion assembly (lower part).
- Push the sensor cable with the sensor connector first through the middle piece ①.
- Thread the other end of the sensor cable through the cap with cable gland in the drawing (to signal converter). Do not tighten the cable gland yet.
- Push the cap onto the immersion assembly again ②.
- Make sure that the O-ring ④ and the washer ⑤ on the sensor are assembled in the sequence indicated in the drawing.
- Insert the sensor into the protective cage ③ and tighten it by hand ⑥.

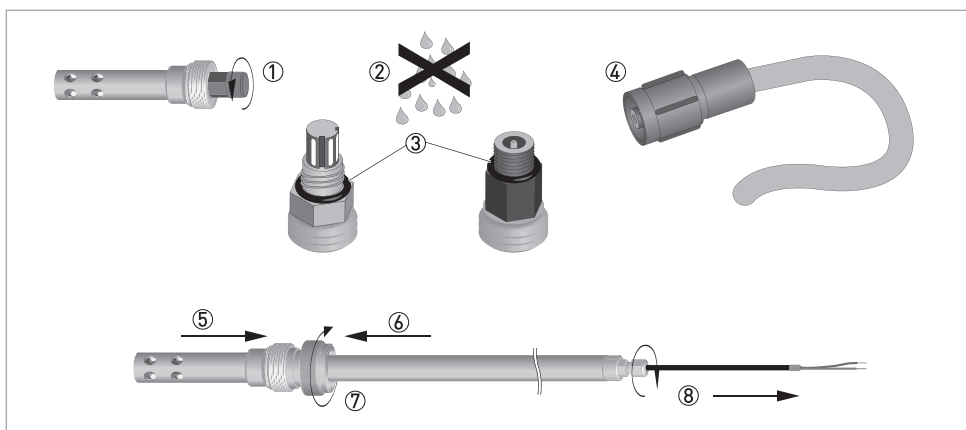

Figure 3-8: Installing a new sensor (step 2)



### Installing a new sensor (step 2)

- Unscrew the protective cap from the sensor ①.
- Make sure that the sensor connector is absolutely dry ② and that the O-ring is in place ③.
- Screw the cable connector ④ on to the sensor.
- Push the protective cage containing the sensor into the immersion assembly ⑤.
- Push the union nut over the thread ⑥ and tighten it by hand ⑦.
- Gently pull excess cable through the cable gland without stretching the cable ⑧.
- Tighten the cable gland.
- Mount the immersion assembly using the provided clamps.



#### INFORMATION!

*It is not necessary to tighten the sensor with a special device. Tighten the sensor by hand is absolutely sufficient*



### 3.7 Examples of a typical measuring point

The following examples each show the signal converter, a sensor with or without integrated temperature measurement, and the flow-through or immersion assembly.

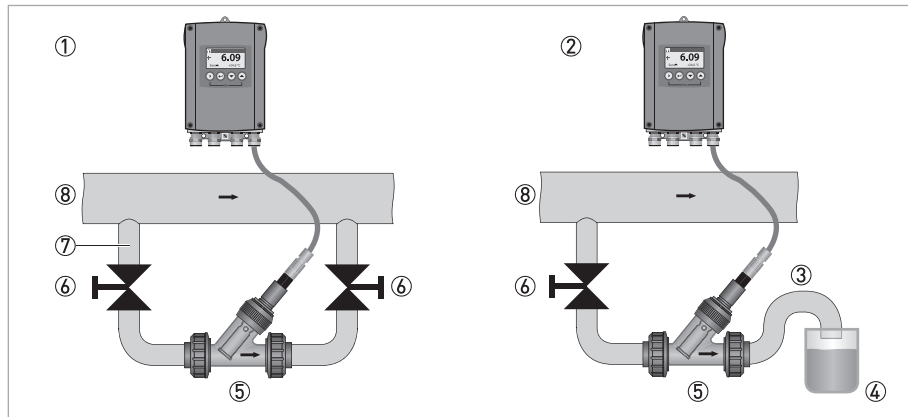

Figure 3-9: Measuring point using the flow-through assembly

- ① Bypass measurement
- ② Outlet measurement
- ③ Elbow pipe
- ④ Sample vial
- ⑤ Flow-through assembly with sensor
- ⑥ Shut-off valve
- ⑦ Bypass pipe
- ⑧ Main pipe

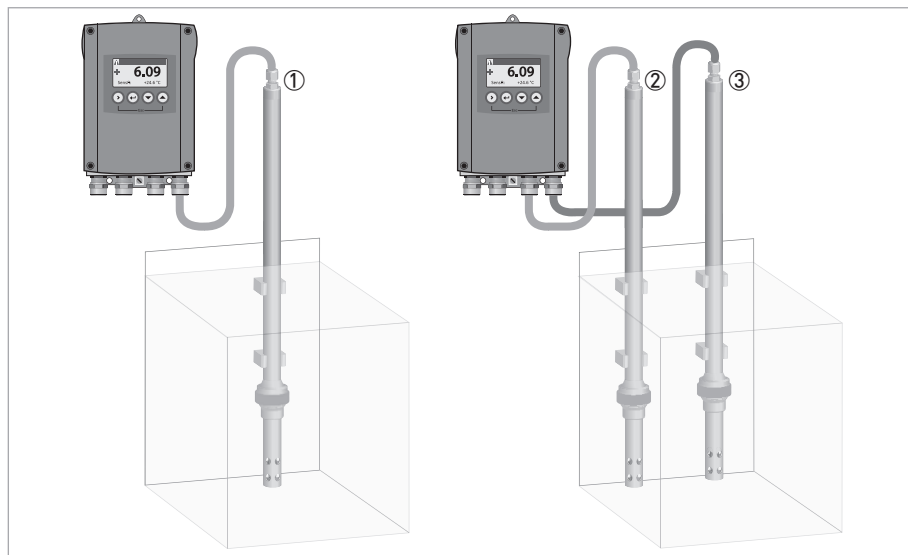

Figure 3-10: Measuring point using the immersion assembly

- ① ORP on single channel instrument
- ② ORP or ORP (optimal with temperature)
- ③ ORP (optimal with temperature)

## 4.1 Safety instructions

**DANGER!**

*For devices used in hazardous areas, additional safety notes apply; please refer to the Ex documentation.*

**DANGER!**

*All work on the electrical connections may only be carried out with the power disconnected.*

**DANGER!**

*Observe the national regulations for electrical installations!*

**WARNING!**

*Observe without fail the local occupational health and safety regulations. Any work done on the electrical components of the measuring device may only be carried out by properly trained specialists.*

**INFORMATION!**

*Look at the device nameplate to ensure that the device is delivered according to your order.*

### 4.1.1 Connecting the sensor cable to the signal converter



#### **DANGER!**

All work on the electrical connections may only be carried out with the power disconnected. Take note of the voltage data on the nameplate!



#### **INFORMATION!**

Look at the device nameplate to ensure that the device is delivered according to your order. Check for the correct supply voltage printed on the nameplate.

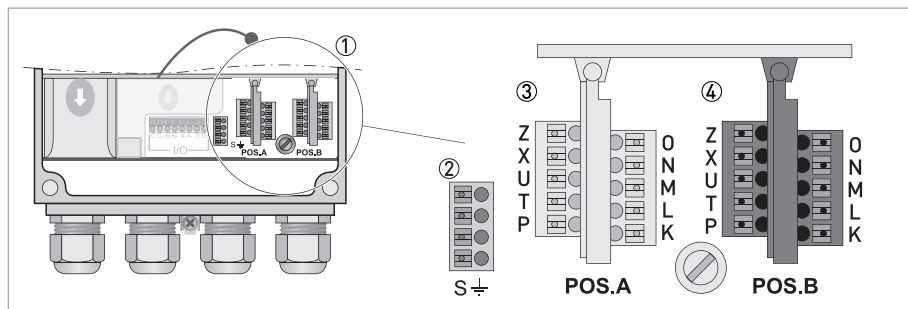

Figure 4-1: Sensor connection terminals on the MAC 100 dual channel version

- ① Sensor connection terminals
- ② Terminal block S (protective earth)
- ③ Terminal block Pos.A: terminal for sensor and temperature
- ④ Terminal block Pos.B: terminal for sensor and temperature

The ORP sensor is connected to the signal converter using a coax cable.

When ordering the one channel version, only the interface "Pos.A" is populated. In the version with two channels the interfaces "Pos.A" and "Pos.B" are populated.

Wire	Terminal block Pos.A/B
<b>OPTISENS ORP 8500 with coax cable (without integrated Pt100/1000)</b>	
Coax shield (red)	N (ref.)
Coax core (transparent)	O (pH/ORP)

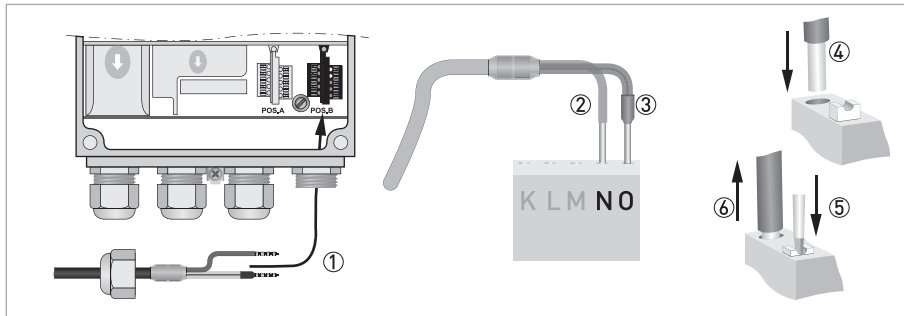

The following instructions describe the connection of the different sensor cables.



### Connecting the sensor cable to the signal converter

- Thread the sensor cable through the outer right cable gland ①.
- Push the coax shield ④ into terminal N ② and the coax core into terminal O ③.
- To remove a cable, press down the white clip ⑤ on the corresponding terminal and pull the cable out ⑥.

#### 4.1.2 Connecting the external temperature sensor

Connect an external Pt100 or Pt1000 sensor to terminal block Pos.A/B of the signal converter according to the following drawings:

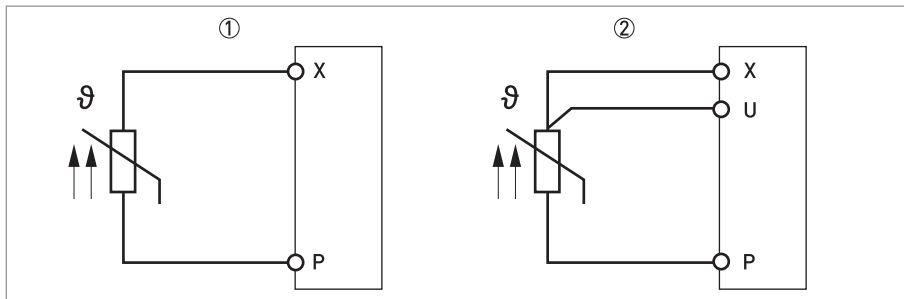

Figure 4-2: Connection of an external Pt100/1000 temperature sensor to the signal converter (2-wire connection)

- ① 2-wire connection
- ② 3-wire connection

### 4.1.3 Connecting the cable to the sensor

**CAUTION!**

Moisture on the sensor connector must be avoided! Moisture may cause a short-circuit and a malfunction of the sensor!

If moisture has entered the connector dry it with air (e.g. hot air gun).

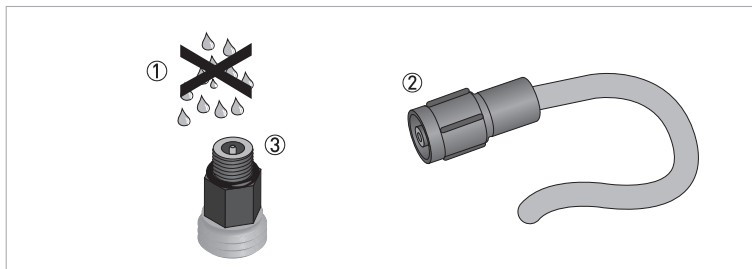

Figure 4-3: Connecting the cable to the sensor

**Connecting the cable to the sensor**

- Ensure that the cable and the sensor connector are absolutely dry ①.
- Screw the cable connector ② on to the sensor connector ③ and tighten it by hand.

### 5.1 Menu mode structure



**INFORMATION!**

The following table just presents an overview. Additional levels are accessible from certain menus offering the possibility to change presets.

Measuring mode	Main menu	Submenu			Parameter			
3 or 4 pages, scrolling with ↓ or ↑	> 2.5 s ←	<b>A quick setup</b>	> ←	A1 language	> ←	For further information see function tables.		
			A2 tag					
				A3 hold function				
				A4 set clock				
				A5 reset errors				
			A6 analog outputs	> ←	A6.1 measurement			
					A6.3 range			
					A6.4 time constant			
			A7 start calib. A		A7.1 ORP cal. A process input A ORP calibration			
			A12 start calib. ORP		A12.1 ORP calibration B process input B ORP calibration			
		↓↑		↓↑	↓↑	↓↑		
	> 2.5 s ←	<b>B test</b>	> ←	B1 sim. process inp. A	> ←	B1.1 temperature B1.5 ORP	> ←	For further information see function tables.
			B2 sim. process inp.B		B2.1 temperature B2.5 ORP			
		↓↑		↓↑	↓↑	↓↑	↓↑	

Measuring mode	Main menu	Submenu	Parameter
3 or 4 pages, scrolling with ↓ or ↑	> 2.5 s ←	<b>B test</b>	> B3 simulation I/O ←
			> B3.1 current output A ← B3.2 current output B B3.3 current output C B3.4 simulation R1 B3.5 simulation R2 B3.6 simulation R3 B4.1 operating hours B4.2 process input A B4.2.1 temperature B4.2.7 ORP B4.2.11 electrode voltage B4.3 process input B B4.3.1 temperature B4.3.7 ORP B4.3.11 electrode voltage B5.1 status log B5.2 calibration log B6.1 C number B6.2 process input A B6.3 process input B B6.4 SW.REV. MS B6.5 SW.REV. UIS B6 Electronic Revision ER
	↓↑	↓↑	↓↑
> 2.5 s ←	<b>C setup</b>	> C1 process input A ←	> C1.1 parameter (pH/ORP) ← C1.8 zero point C1.14 time constant C1.16 ORP cal. C2.1 parameter (pH/ORP) C2.8 zero point C2.14 time constant C2.16 ORP cal.
	↓↑	↓↑	↓↑

Measuring mode	Main menu	Submenu			Parameter
3 or 4 pages, scrolling with ↓ or ↑	> 2.5 s ←	<b>C setup</b>	> C3 I/O	> C3.1 hardware	> For further information see function tables. ←
				← C3.2 current output A	
				← C3.3 current output B	
				← C3.4 current output C	
			C5 device	> C5.1 device info	
				← C5.2 display	
				← C5.3 1.meas.page	
				← C5.4 2.meas.page	
				← C5.5 graphic page	
				← C5.6 special functions	
				← C5.7 units	
		↓↑	↓↑	↓↑	↓↑
<b>D service:</b> This menu is password protected and contains functions to be used by service personnel only.					

## 5.2 Function tables

### 5.2.1 Menu A, quick setup



**INFORMATION!**

Note that the appearance of some sub-menus depends on the hardware setting and the used sensor(s). Also only the sensor relevant menus and submenus are shown here in detail. For all other menu functions refer to the MAC 100 signal converter manual.

#### A7, ORP cal. A / A12 ORP cal. B

For single or dual channel version: Settings for sensor verification



### 5.2.2 Menu B, test



#### **INFORMATION!**

Note that the appearance of some sub-menus depends on the hardware setting and the used sensor(s). Also only the sensor relevant menus and sub-menus are shown here in detail. For all other menu functions refer to the MAC 100 signal converter manual.

The procedure to start the simulation process is the same for all functions:



- Choose the function with the help of ↓ or ↑ and press ←.
- ➡ You see the two options "set value" (opens the editor to enter the simulation value) and "break" (exits the menu without simulation).
- Choose the desired option with the help of ↑ or ↓ and press ←.
- ➡ If you chose "set value", the device asks "start simulation" and offers the options "no" (exits the menu without simulation) or "yes" (starts the simulation finally).
- Choose the desired option with the help of ↑ or ↓ and press ←.
- ➡ If you chose "yes", the simulation starts.

B1,sim.process inp.A

B2,sim.process inp.B

Menu point	Designation / function	Settings / descriptions
B1.1 B2.1	temperature	In this menu the temperature can be simulated.
B1.5 B2.5	ORP	In this menu the relative concentration of ORP can be simulated.

### B4, actual values

Menu point	Designation / function	Settings / descriptions
This menu groups several functions which allow to display the corresponding actual reading. The shown measurements are depending on the device configuration.		
B4.1	operating hours	This menu shows the operating time of the devices in hours.
B4.2	process input A	In this menu the measurements from process input A can be read.
B4.3	process input B	In this menu the measurements from process input B can be read.

### 5.2.3 Menu C, setup



#### **INFORMATION!**

The signal converter has a dual process input, A and B. Each process input has an own submenu in this main menu. Process input A is always present, i.e. there is always a board in the interface "Pos.A" in the connection area. The interface of process input B only has a board with the dual channel signal converter. Be aware that the definition which kind of measurement a process input can do is defined when ordering the device. The configuration cannot be changed later.



#### **INFORMATION!**

Note that the appearance of some submenus depends on the hardware setting and the used sensor(s).

**C1, process input A**  
**C2, process input B**

Menu point	Designation / function	Settings / descriptions
<p>Process input A and B can be either a sensor 1 or a sensor 2. Further information about the type of sensor 1 or 2 please refer to MAC 100 manual "Sensor input combinations". Process input A is always present, process Input B can be present.            Note: The exchange of a sensors 1 with a sensor 2, or vice versa, can only be done by the manufacturer!            Depending on the sensor which is connected to a slot A or B the menu changes.</p>		
<b>C1.1</b> <b>C2.1</b>	parameter pH parameter ORP	This menu item is for selecting the probe which is connected to process input A/B. The entries of this selection depends on the chosen device configuration. The device configuration is customer specific and set during production.
<b>C1.8</b> <b>C2.8</b>	zero point	This menu item shows the actual zero point to the calibrated pH/ORP sensor.
<b>C1.9</b> <b>C2.9</b>	slope	This menu item shows the actual slope point to the calibrated pH/ORP sensor.
<b>C1.16</b> <b>C2.16</b>	ORP cal.	Menu item for calibrating the ORP sensor.
C1.16.1 C2.16.1	prepare calibration	View actual ORP value.
C1.16.2 C2.16.2	ref. value ORP	Enter the reference value of the probe in mV.
C1.16.3 C2.16.3	start calibration?	Start calibration procedure.
C1.16.4 C2.16.4	stored value	View stored value of calibration.

## 5.3 Calibration

### 5.3.1 Calibrating ORP measurement

**CAUTION!**

- Never touch or scratch the platinum measuring tip of the ORP sensor.
- Make sure that the glass tip is clean and dust-free. If necessary, clean the tip as described in the manual of the sensor.

**CAUTION!**

Moisture on the sensor connector must be avoided! Moisture may cause a short-circuit and a malfunction of the sensor!  
If moisture has entered the connector dry it with air (e.g. hot air gun).

**INFORMATION!**

Remove the watering cap before starting the calibration.

The potential of an ORP electrode is calibrated using a ORP buffer solution. In the course of that, the difference between the measured potential and the potential of the calibration solution is determined. This potential difference is printed on the buffer solution bottle and is defined as the voltage across the ORP electrode and a reference electrode. ORP sensors require no calibration, but you can perform a one-point offset calibration with an ORP buffer solution.

To avoid alarms on the distributed control system (DCS) when temporarily removing the sensor (i.e. for maintenance), the signal converter has a hold function. This function "freezes" all outputs (i.e. the display and the current outputs) of the last measured value.

**INFORMATION!**

As an indication that the manual hold function is active, the "warning sign" in the upper left corner of the display appears. Meanwhile the status messages show "checks in progress". For more details about how to select the manual hold function refer to the signal converter manual.

After starting-up the signal converter, the measuring screen appears. This is the standard screen which is displayed automatically in the normal operating mode. If you are in this mode and you want to initiate a calibration, you have to activate the manual hold function in the first step.

**Step 1: activating the hold function**

<ul style="list-style-type: none"> <li>• Press &gt; for more than 2.5 seconds, then release the button. You are on the main menu level. In the upper line of the display "A" appears, beneath the main menu <b>quick setup</b> is highlighted.</li> <li>• Press ▼ or ▲ until the main menu <b>quick setup</b> is highlighted.</li> </ul>	
	<p>MAIN MENU</p> <p>&gt; A quick setup B test C setup D service</p>
<ul style="list-style-type: none"> <li>• Press &gt; to enter the chosen menu.</li> </ul>	
	<p>You are on the first submenu level. In the upper line of the display "quick setup" and "A1" appears, beneath the submenu <b>language</b> is highlighted.</p> <ul style="list-style-type: none"> <li>• Press ▼ or ▲ until the submenu <b>hold function</b> is highlighted.</li> <li>• Press &gt; to enter the chosen menu.</li> </ul>
	<p>You are on the second submenu level. In the upper line of the display "manual hold" appears, beneath the option <b>off</b> is highlighted</p> <ul style="list-style-type: none"> <li>• Press ▼ or ▲ to choose the option on</li> <li>• Press ↵ to confirm the entered value.</li> </ul>



- You have activated the hold function. Go to the next step and prepare the calibration procedure. You have to return to the measuring mode.
- Press ↵ until you reach the measuring mode again.

**Step 1a: accessing the calibration menu via the main menu setup**

<ul style="list-style-type: none"> <li>• Press &gt; for more than 2.5 seconds, then release the button. You are on the main menu level. In the upper line of the display "A" appears, beneath the main menu <b>quick setup</b> is highlighted.</li> <li>• Press ▼ or ▲ until the main menu <b>setup</b> is highlighted.</li> </ul>	
	<p>MAIN MENU</p> <p>A quick setup B test &gt; C setup D service</p>
<ul style="list-style-type: none"> <li>• Press &gt; to enter the chosen menu.</li> </ul>	
	<p>You are on the first submenu level. In the upper line of the display "setup" and "c1" appears, beneath the submenu <b>process input A</b> is highlighted.</p> <p>Press ▼ or ▲ to select <b>process input A</b> or <b>process input B</b> is highlighted. Choose process input A or B.</p> <ul style="list-style-type: none"> <li>• Press &gt; to enter the chosen menu.</li> </ul>
	<ul style="list-style-type: none"> <li>• You are on the second submenu level. The submenu <b>ORP cal.</b> is highlighted.</li> <li>• Press &gt; to enter the chosen menu.</li> </ul>



- You can start the calibration procedure now as described in "Step 2".

### Step 1b: accessing the calibration menu via the main menu **quick setup**

<ul style="list-style-type: none"> <li>Press <b>&gt;</b> for more than 2.5 seconds, then release the button. You are on the main menu level. In the upper line of the display "A" appears, beneath the main menu <b>quick setup</b> is highlighted.</li> </ul>	
MAIN MENU	
<ul style="list-style-type: none"> <li><b>&gt; A quick setup</b></li> <li>B test</li> <li>C setup</li> <li>D service</li> </ul>	
<ul style="list-style-type: none"> <li>Press <b>&gt;</b> to enter the chosen menu.</li> </ul>	
You are on the first submenu level. In the upper line of the display "quick setup" and "a" appears, beneath the submenu <b>language</b> is highlighted.	
Press <b>▼</b> or <b>▲</b> until the submenu <b>ORP calibration A</b> or <b>B</b> is highlighted.	
<ul style="list-style-type: none"> <li>Press <b>&gt;</b> to enter the chosen menu.</li> </ul>	
<ul style="list-style-type: none"> <li>You can start the calibration procedure now as described in "Step 2".</li> </ul>	



- You can start the calibration procedure now as described in "Step 2".



### Step 2: preparing the calibration procedure

- If you re-calibrate an existing sensor, remove the sensor from its respective assembly.
- If you calibrate a new sensor, make sure that the sensor is correctly connected to the signal converter.
- Check the sensor for damages, check the diaphragm for coating and rinse the sensor tip with tap water and gently swipe it with a soft tissue.
- Provide a suitable calibration solution.

After activating the hold function and the preparative measures, you can get access to the calibration procedure from the measuring mode in two different ways. Either you go via the main menu **setup** (step 3a) or via the main menu **quick setup** (step 3b).



#### **INFORMATION!**

*If an error occurs during the calibration procedure, the display shows an error message.*



### Step 3: calibration procedure

- After choosing the submenu **ORP** (step 1a) or **ORP calibration A or B** (step 1b) and step 2 in the previous steps, continue by pressing **>**.
  - The currently measured value is shown on the display.
- Press **↵** to finally start the calibration procedure.
- Submerge the sensor tip into the ORP buffer solution.
- Wait until a steady value is displayed.
- Press **↵** to continue the calibration procedure.
  - The message **ref. value ORP** and the value of the buffer solution are displayed on the screen.
- Enter the value of the buffer solution by pressing **▼** or **▲** and **>**. Press **↵** to confirm the setting.
- After 25 seconds the calibration step is completed.
  - The message zero point is displayed on the screen.
- Press **↵** to confirm the setting.
  - The message store cal. value is displayed on the screen. The signal converter asks if the new calibration values should be stored.

- Choose **yes** using ▼ or ▲ to store the calibration values. Choose **no** to discard the results.
- Press ↵ to confirm.
- If you want to return to the measuring mode, press ↵ several times until you reach this mode. Prior returning to the measuring display, you are asked if the configuration should be stored. Choose **yes** using ▼ or ▲ to store the new calibration values. Press ↵ to confirm.



#### Step 4: re-installing the sensor

- After the calibration procedure, rinse the sensor with tap water.
- Reinstall the sensor into its assembly, refer to *Installing the sensor* on page 13.



#### Step 5: switching back to measurement

- Deactivate the function **hold function** again.

### 5.3.2 Calibration log



#### INFORMATION!

*In order to show the history of the calibrations, the signal converter has a calibration logbook function. Up to 64 entries of the calibration history are stored including date and time.*

#### Accessing the calibration log

- Press > for more than 2.5 seconds, then release the button. You are on the main menu level. In the upper line of the display "A" appears, beneath the main menu **quick setup** is highlighted.
- Press ▼ or ▲ until the main menu **test** is highlighted.

	MAIN MENU A quick setup > B test C setup D service
	Press > to enter the chosen menu.
	You are on the first submenu level. In the upper line of the display "test" and "B1" appears, beneath the submenu <b>sim.process input A</b> is highlighted.
	Press ▲ or ▼ until the submenu <b>logbooks</b> is highlighted.
	Press > to enter the chosen menu.
	You are on the second submenu level. In the upper line of the display "logbooks" and "B1" appears, beneath the submenu <b>status log</b> is highlighted.
	Press ▼ or ▲ until the submenu <b>calibration log</b> is highlighted.
	Press > to enter the chosen menu.



- You are on the data level and you see the calibration history. With the help of ▼ or ▲ you can scroll through the different entries.
- If you want to return to the measuring mode press ↵ several times until you reach this mode.

## 5.4 Troubleshooting

Problem	Possible cause	Remedy
The ORP sensor does not deliver a signal.	Mechanical damage of the platinum electrode, e.g. scratches.	Exchange sensor.
	Moisture inside the sensor connector.	Clean the connector (sensor/cable) with pure water and dry with air (e.g. hair blower).
The ORP sensor delivers a bad signal.	Coated/abraded platinum electrode.	Clean the platinum electrode by using aqua regia (this procedure uses hazardous chemicals and should only be performed by a qualified person), HCl concentrated/HNO <sub>3</sub> concentrated (1/1).
The ORP electrode delivers an unstable signal.	The diaphragm in the reference half-cell does not provide good contact to the process medium due to drying up or coatings.	Clean the diaphragm with hot soap or acid using a soft tissue (details on page 32). Submerge sensor in water and increase the temperature to 50...60°C / 122...140°F. Submerge sensor in 3 molar KCl solution at ambient temperature. The decrease in temperature will cause the reference half cell to suck in KCl solution through the diaphragm and regenerate the diaphragms functionality.

## 6.1 Maintenance

### 6.1.1 Cleaning

**INFORMATION!**

*Recalibrate the sensor after each manual cleaning procedure.*



- Clean the platinum sensor surface with demineralised water.
- Slight dirt residues or dust: Rinse the sensor tip with demineralised water and clean it with a soft tissue.
- Oily and greasy coatings: Remove with a warm soap solution and rinse with demineralised water.
- Hardness deposits or metal hydroxide deposits: Soak the sensor tip including diaphragm in 10% citric acid or hypochloric acid for a couple of minutes and rinse the complete glass shaft of the sensor with demineralised water.
- Biological fouling: Soak the sensor tip including diaphragm in 10% pepsin solution for minimum 3 hours and afterwards rinse the complete glass shaft of sensor with demineralised water.

### 6.1.2 Aging and re-calibration

During operation, but already during storage, ORP sensors age due to poisoning effects of the inner buffer system. Therefore it is important to re-calibrate the sensors in regular intervals as described on page 27.

**Aging effects ORP sensors:**

- **Shift of zero point:** Compare the zero point shift (use a ORP solution, e.g. 465 mV) with the sensor-specific offset value of the last calibration. In this case dip the sensor tip into the ORP solution and read the measured value. If the measured value deviates +/- 15 mV from the value of the ORP solution, a calibration is required. For more information refer to *Calibration* on page 27.

## 6.2 Spare parts availability

The manufacturer adheres to the basic principle that functionally adequate spare parts for each device or each important accessory part will be kept available for a period of 3 years after delivery of the last production run for the device.

This regulation only applies to spare parts which are subject to wear and tear under normal operating conditions.

## 6.3 Availability of services

The manufacturer offers a range of services to support the customer after expiration of the warranty. These include repair, maintenance, technical support and training.

**INFORMATION!**

*For more precise information, please contact your local sales office.*



## 6.4 Returning the device to the manufacturer

### 6.4.1 General information

This device has been carefully manufactured and tested. If installed and operated in accordance with these operating instructions, it will rarely present any problems.



**CAUTION!**

*Should you nevertheless need to return a device for inspection or repair, please pay strict attention to the following points:*

- *Due to statutory regulations on environmental protection and safeguarding the health and safety of the personnel, the manufacturer may only handle, test and repair returned devices that have been in contact with products without risk to personnel and environment.*
- *This means that the manufacturer can only service this device if it is accompanied by the following certificate (see next section) confirming that the device is safe to handle.*



**CAUTION!**

*If the device has been operated with toxic, caustic, flammable or water-endangering products, you are kindly requested:*

- *to check and ensure, if necessary by rinsing or neutralising, that all cavities are free from such dangerous substances,*
- *to enclose a certificate with the device confirming that is safe to handle and stating the product used.*

### 6.4.2 Form (for copying) to accompany a returned device



**CAUTION!**

*To avoid any risk for our service personnel, this form has to be accessible from outside of the packaging with the returned device.*

Company:		Address:	
Department:		Name:	
Tel. no.:		Fax no. and/or Email address:	
Manufacturer's order no. or serial no.:			
The device has been operated with the following medium:			
This medium is:	<input type="checkbox"/>	radioactive	
	<input type="checkbox"/>	water-hazardous	
	<input type="checkbox"/>	toxic	
	<input type="checkbox"/>	caustic	
	<input type="checkbox"/>	flammable	
	<input type="checkbox"/>	We checked that all cavities in the device are free from such substances.	
<input type="checkbox"/>	We have flushed out and neutralized all cavities in the device.		
We hereby confirm that there is no risk to persons or the environment through any residual media contained in the device when it is returned.			
Date:		Signature:	
Stamp:			

### 6.5 Disposal



**CAUTION!**

*Disposal must be carried out in accordance with legislation applicable in your country.*

**Separate collection of WEEE (Waste Electrical and Electronic Equipment) in the European Union:**



According to the directive 2012/19/EU, the monitoring and control instruments marked with the WEEE symbol and reaching their end-of-life **must not be disposed of with other waste**.

The user must dispose of the WEEE to a designated collection point for the recycling of WEEE or send them back to our local organisation or authorised representative.

## 7.1 Measuring principle

### 7.1.1 ORP measurement

The oxidation reduction potential, ORP in short, is the measurement for the concentration of oxidising and reducing agents in water. Its value is influenced both by pH and temperature. ORP is a sum parameter that gives no information on the concentration of a single substance in a mixture.

ORP measurements are used to monitor chemical reactions involving electron transfer. In drinking water treatment it can be found in ozone treatment and the removal of iron, manganese and nitrate as well as in disinfection steps. In swimming pools the German DIN 19643 requires ORP measurements as a hygiene parameter and decrees maximum and minimum values for fresh water, pool water, and salt water. In wastewater treatment ORP is measured in the denitrification process and in detoxication of industrial wastewater.

The ORP sensor consists of a measuring electrode of platinum or gold and a reference of e.g. Ag/AgCl. The potential of the measuring electrode changes with the concentration of reducing and oxidising agents and is measured against the reference. The measured values can be recalculated to fit literature values based on NHE (normal hydrogen electrode) as reference.

## 7.2 Technical data



### INFORMATION!

- The following data is provided for general applications. If you require data that is more relevant to your specific application, please contact us or your local sales office.
- Additional information (certificates, special tools, software,...) and complete product documentation can be downloaded free of charge from the website (Downloadcenter).

### Measuring system

Measuring principle	Potentiometric
Measuring range	-1500...+1500 mV

### Design

Construction	Glass sensor
Shaft diameter	12 mm / 0.47"
Length	120 mm / 4.72"
Process connection	PG 13.5
Sensor cap	S8
Type of diaphragm	Ceramic

### Measuring accuracy

Reference conditions	Medium: water
	Temperature: 20°C / 68°F
	Pressure: max. 1 bar / 14.5 psi (absolute)
Measuring error	0.3% full scale
Repeatability	<0.2% full scale
Resolution	0.1 (or 0.01 in extended mode)

**Operating conditions**

Temperature range	-5...+70°C / +23...+158°F
Max. operating pressure	<2 bar / 29 psi
Minimum conductivity	>150 µS/cm

**Installation conditions**

Process connection	PG 13.5
Immersion assemblies	SENSOFIT IMM 1000
Flow-through assemblies	SENSOFIT FLOW 1000
Insertion assemblies	SENSOFIT INS 1000 series

**Materials**

Sensor shaft	Glass
Measuring electrode	Platinum
Reference	Ag/AgCl/Tepox gel
Diaphragm	Ceramic
Gasket	EPDM

**Electrical connection**

Connector	S8
Cable	Cable pH/ORP-W-Coax
Cable length	5 m / 16.4 ft; 10 m / 33 ft; 15 m / 49 ft

### 7.3 Dimensions

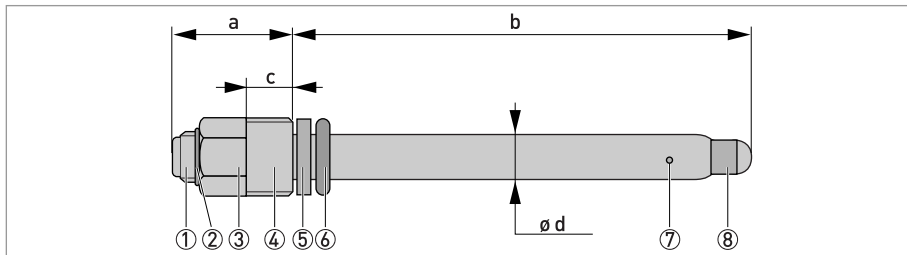

Figure 7-1: Dimensions of OPTISENS ORP 8500

- ① Thread for sensor cable connector
- ② O-ring
- ③ Hexagonal nut
- ④ Thread
- ⑤ Washer
- ⑥ O-ring
- ⑦ Diaphragm
- ⑧ Pt-Ring

	Dimensions [mm]	Dimensions [inch]
a	31	1.2
b	120	4.7
c	12	0.5
d	Ø12	Ø0.5
e	6	0.2
f	Ø8	Ø0.3

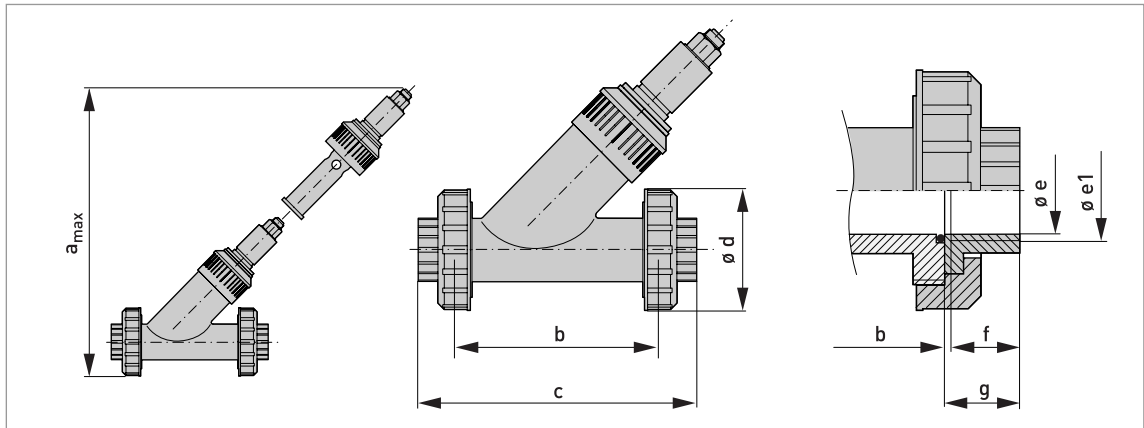

Figure 7-2: Dimensions SENSOFIT FLOW 1000

	Dimensions [mm]	Dimensions [inch]
$a_{max}$	165	6.5
b	142.5	5.61
c	178.5	7.03
d	Ø 75	Ø 2.95
e	Ø 21	Ø 1.26
e1	G1	G1
f	19.1	0.75
g	22	0.87

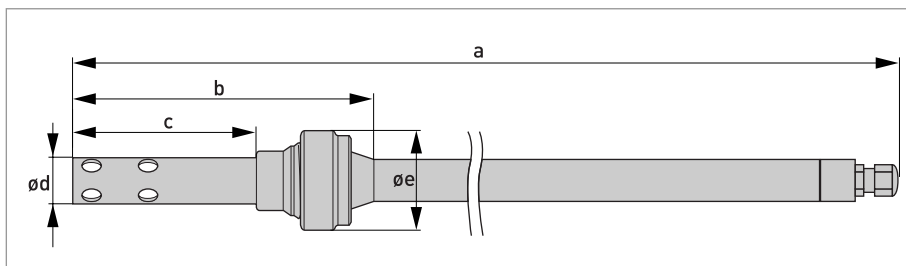

Figure 7-3: Dimensions SENSOFIT IMM 1000

	Dimensions [mm]	Dimensions [inch]
a	1030 (may be shortened)	40.55 (may be shortened)
b	160	6.3
c	100	3.94
d	Ø 25	Ø 0.98
e	Ø 59	Ø 2.32



## KROHNE – Process instrumentation and measurement solutions

- Flow
- Level
- Temperature
- Pressure
- Process Analysis
- Services

Head Office KROHNE Messtechnik GmbH  
Ludwig-Krohne-Str. 5  
47058 Duisburg (Germany)  
Tel.: +49 203 301 0  
Fax: +49 203 301 10389  
info@krohne.com

The current list of all KROHNE contacts and addresses can be found at:  
[www.krohne.com](http://www.krohne.com)

**KROHNE**