



OPTISOUND 3030 C Handbook

Ultrasonic Level Transmitter

Profibus PA

KROHNE

Contents

1	About this document	
1.1	Function	4
1.2	Target group	4
1.3	Symbols used.....	4
2	For your safety	
2.1	Authorised personnel	5
2.2	Appropriate use.....	5
2.3	Warning about incorrect use.....	5
2.4	General safety instructions	5
2.5	Safety label on the instrument	6
2.6	CE conformity.....	6
2.7	Fulfillment of NAMUR recommendations	6
3	Product description	
3.1	Configuration.....	7
3.2	Principle of operation.....	8
3.3	Packaging, transport and storage.....	8
4	Mounting	
4.1	General instructions	10
4.2	Mounting instructions	11
5	Connecting to power supply	
5.1	Preparing the connection	18
5.2	Connection procedure.....	19
5.3	Wiring plan, single chamber housing.....	20
5.4	Wiring plan, double chamber housing	22
5.5	Switch-on phase.....	23
6	Set up with the display and adjustment module	
6.1	Insert display and adjustment module	24
6.2	Adjustment system	25
6.3	Setup steps	26
6.4	Menu schematic.....	37
6.9	Saving the parameter adjustment data.....	39
7	Maintenance and fault rectification	
7.1	Maintenance	40
7.2	Rectify faults.....	40
7.3	Exchanging the electronics module.....	40
7.4	Instrument repair	41
8	Dismount	
8.1	Dismounting steps.....	42
8.2	Disposal	42
9	Supplement	
9.1	Technical data	43
9.2	Profibus PA.....	46
9.3	Dimensions	50

**Safety instructions for Ex areas**

Take note of the Ex specific safety instructions for Ex applications. These instructions are attached as documents to each instrument with Ex approval and are part of the operating instructions manual.

Editing status: 2015-08-18

1 About this document

1.1 Function

This operating instructions manual provides all the information you need for mounting, connection and setup as well as important instructions for maintenance and fault rectification. Please read this information before putting the instrument into operation and keep this manual accessible in the immediate vicinity of the device.

1.2 Target group

This operating instructions manual is directed to trained specialist personnel. The contents of this manual should be made available to these personnel and put into practice by them.

1.3 Symbols used



Information, tip, note

This symbol indicates helpful additional information.



Caution: If this warning is ignored, faults or malfunctions can result.



Warning: If this warning is ignored, injury to persons and/or serious damage to the instrument can result.



Danger: If this warning is ignored, serious injury to persons and/or destruction of the instrument can result.



Ex applications

This symbol indicates special instructions for Ex applications.



SIL applications

This symbol indicates instructions for functional safety which must be taken into account particularly for safety-relevant applications.



List

The dot set in front indicates a list with no implied sequence.



Action

This arrow indicates a single action.



Sequence of actions

Numbers set in front indicate successive steps in a procedure.



Battery disposal

This symbol indicates special information about the disposal of batteries and accumulators.

2 For your safety

2.1 Authorised personnel

All operations described in this operating instructions manual must be carried out only by trained specialist personnel authorised by the plant operator.

During work on and with the device the required personal protective equipment must always be worn.

2.2 Appropriate use

OPTISOUND 3030 C is a sensor for continuous level measurement.

You can find detailed information about the area of application in chapter "*Product description*".

Operational reliability is ensured only if the instrument is properly used according to the specifications in the operating instructions manual as well as possible supplementary instructions.

For safety and warranty reasons, any invasive work on the device beyond that described in the operating instructions manual may be carried out only by personnel authorised by the manufacturer. Arbitrary conversions or modifications are explicitly forbidden.

2.3 Warning about incorrect use

Inappropriate or incorrect use of the instrument can give rise to application-specific hazards, e.g. vessel overfill or damage to system components through incorrect mounting or adjustment.

2.4 General safety instructions

This is a state-of-the-art instrument complying with all prevailing regulations and guidelines. The instrument must only be operated in a technically flawless and reliable condition. The operator is responsible for the trouble-free operation of the instrument.

During the entire duration of use, the user is obliged to determine the compliance of the necessary occupational safety measures with the current valid rules and regulations and also take note of new regulations.

The safety instructions in this operating instructions manual, the national installation standards as well as the valid safety regulations and accident prevention rules must be observed by the user.

For safety and warranty reasons, any invasive work on the device beyond that described in the operating instructions manual may be carried out only by personnel authorised by the manufacturer. Arbitrary conversions or modifications are explicitly forbidden.

The safety approval markings and safety tips on the device must also be observed.

2.5 Safety label on the instrument

The safety approval markings and safety tips on the device must be observed.

2.6 CE conformity

The device fulfills the legal requirements of the applicable EC guidelines. By affixing the CE marking, we confirm successful testing of the product.

2.7 Fulfillment of NAMUR recommendations

NAMUR is the automation technology user association in the process industry in Germany. The published NAMUR recommendations are accepted as the standard in field instrumentation.

The device fulfills the requirements of the following NAMUR recommendations:

- NE 21 – Electromagnetic compatibility of equipment
- NE 53 – Compatibility of field devices and display/adjustment components

For further information see www.namur.de.

3 Product description

3.1 Configuration

Scope of delivery

The scope of delivery encompasses:

- OPTISOUND 3030 C ultrasonic sensor
- Optionally mounting strap or compression flange
- Documentation
 - This operating instructions manual
 - Ex-specific safety instructions (with Ex versions)
 - Operating instructions manual "Display and adjustment module" (optional)
 - if necessary, further certificates



Information:

In this operating instructions manual, the optional instrument features are described. The respective scope of delivery results from the order specification.

Constituent parts

The OPTISOUND 3030 C consists of the components:

- Process fitting with transducer
- Housing with electronics
- Housing cover with integrated display and adjustment module (optional)

The components are available in different versions.

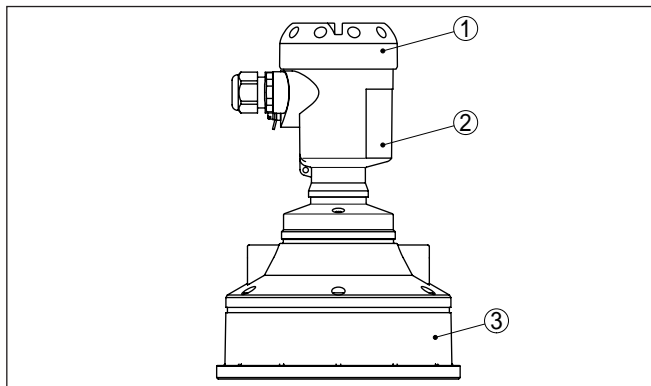

Fig. 1: OPTISOUND 3030 C with plastic housing

- 1 Housing cover with integrated display and adjustment module (optional)
- 2 Housing with electronics
- 3 Process fitting with transducer

Type label

The type label contains the most important data for identification and use of the instrument:

- Instrument type
- Article and serial number device
- Article numbers, documentation

- Technical data: For example approvals, process temperature, process fitting/material, signal output, power supply, protection

3.2 Principle of operation

Application area

OPTISOUND 3030 C is an ultrasonic sensor for continuous level measurement. It is suitable for liquids and solids in practically all industries.

Functional principle

The transducer of the ultrasonic sensor transmits short ultrasonic pulses to the measured product. These pulses are reflected by product surface and received back by the transducer as echoes. The running time of the ultrasonic pulses from emission to reception is proportional to the distance and hence the level. The determined level is converted into an appropriate output signal and outputted as measured value.

Power supply and bus communication

Power supply via the Profibus DP/PA segment coupler. A two-wire cable according to Profibus specification serves as carrier of both power and digital data transmission for multiple sensors. The instrument profile of OPTISOUND 3030 C corresponds to profile specification version 3.0.

GSD/EDD

The GSD (instrument master files) and bitmap files necessary for planning your Profibus-DP-(PA) communication network are available from the download section on our homepage. There you can also find the appropriate certificates. In a PDM environment, an EDD (Electronic Device Description) is also required to enable the full range of sensor functions (also available as a download).

The backlight of the display and adjustment module is powered by the sensor. Prerequisite is a certain level of operating voltage.

The data for power supply are specified in chapter "*Technical data*".

3.3 Packaging, transport and storage

Packaging

Your instrument was protected by packaging during transport. Its capacity to handle normal loads during transport is assured by a test based on ISO 4180.

The packaging of standard instruments consists of environment-friendly, recyclable cardboard. For special versions, PE foam or PE foil is also used. Dispose of the packaging material via specialised recycling companies.

Transport

Transport must be carried out in due consideration of the notes on the transport packaging. Nonobservance of these instructions can cause damage to the device.

Transport inspection

The delivery must be checked for completeness and possible transit damage immediately at receipt. Ascertained transit damage or concealed defects must be appropriately dealt with.

Storage

Up to the time of installation, the packages must be left closed and stored according to the orientation and storage markings on the outside.

Unless otherwise indicated, the packages must be stored only under the following conditions:

- Not in the open
- Dry and dust free
- Not exposed to corrosive media
- Protected against solar radiation
- Avoiding mechanical shock and vibration

Storage and transport temperature

- Storage and transport temperature see chapter "*Supplement - Technical data - Ambient conditions*"
- Relative humidity 20 ... 85 %

4 Mounting

4.1 General instructions

Installation position

Select an installation position you can easily reach for mounting and connecting as well as later retrofitting of a display and adjustment module. The housing can be rotated by 330° without the use of any tools. You can also install the display and adjustment module in four different positions (each displaced by 90°).

Moisture

Use the recommended cables (see chapter "*Connecting to power supply*") and tighten the cable gland.

You can give your OPTISOUND 3030 C additional protection against moisture penetration by leading the connection cable downward in front of the cable entry. Rain and condensation water can thus drain off. This applies mainly to outdoor mounting as well as installation in areas where high humidity is expected (e.g. through cleaning processes) or on cooled or heated vessels.

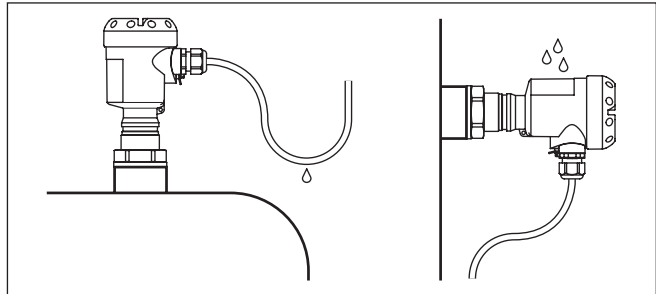

Fig. 2: Measures against moisture ingress

Cable entries - NPT thread

In the case of instrument housings with self-sealing NPT threads, it is not possible to have the cable entries screwed in at the factory. The free openings for the cable glands are therefore covered with red dust protection caps as transport protection.

Prior to setup you have to replace these protective caps with approved cable glands or close the openings with suitable blind plugs.

Measuring range

The reference plane for the measuring range is the lower edge of the transducer.

Make sure that a minimum distance from the reference plane - the so-called dead zone, in which measurement is not possible - is maintained. The exact value of the dead zone is stated in chapter "*Technical data*".

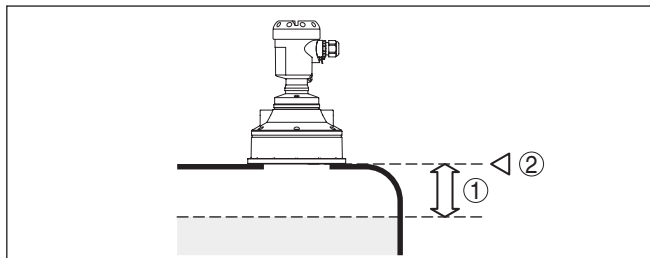

Fig. 3: Minimum distance to the max. level

- 1 Dead zone
- 2 Reference plane



Information:

If the medium reaches the transducer, buildup can form on it and cause faulty measurements later on.

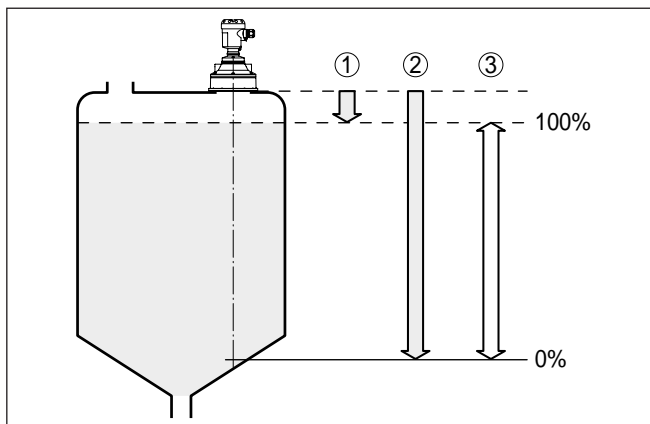

Fig. 4: Measuring range (operating range) and max. measuring distance

- 1 full
- 2 empty (max. measuring distance)
- 3 Measuring range

Pressure/Vacuum

Gauge pressure in the vessel does not influence OPTISOUND 3030 C. Low pressure or vacuum does, however, damp the ultrasonic pulses. This influences the measuring result, particularly if the level is very low. With pressures under -0.2 bar (-20 kPa) you should use a different measuring principle, e.g. radar or guided radar (TDR).

4.2 Mounting instructions

When mounting the OPTISOUND 3030 C, keep a distance of at least 200 mm (7.874 in) to the vessel wall. If the sensor is installed in the center of dished or round vessel tops, multiple echoes can arise. These can, however, be suppressed by an appropriate adjustment (see chapter "Setup").

Installation position

If this distance cannot be maintained, a false signal storage should be carried out during setup. This applies particularly if buildup on the vessel wall is expected. In such cases, we recommend repeating the false signal storage at a later date with existing buildup.

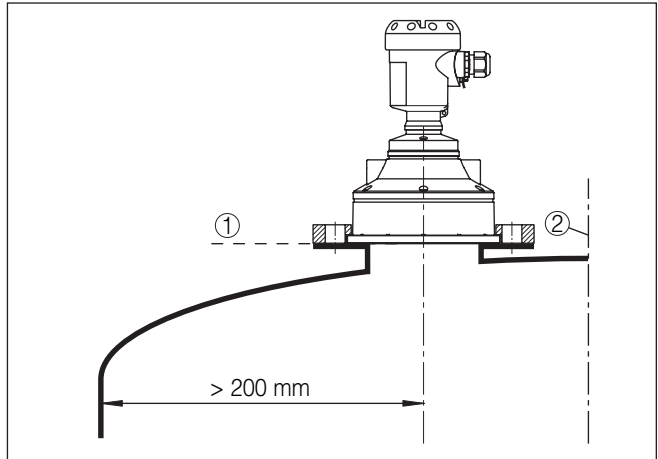

Fig. 5: Mounting on round vessel tops

- 1 Reference plane
- 2 Vessel center or symmetry axis

In vessels with conical bottom it can be advantageous to mount the sensor in the center of the vessel, as measurement is then possible down to the lowest point of the vessel bottom.

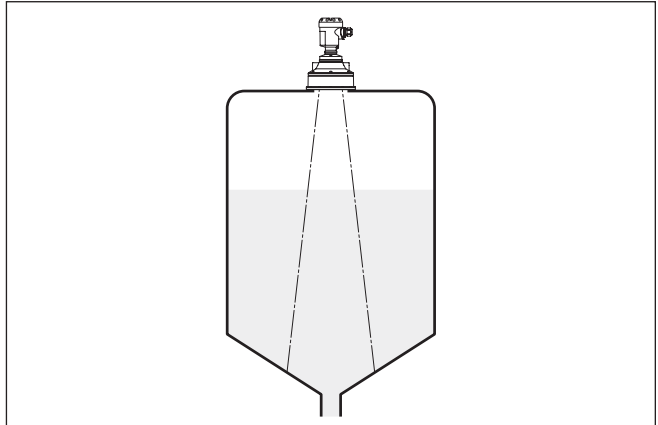

Fig. 6: Vessel with conical bottom

Socket

Preferably the transducer should be mounted flush to the vessel top. If the reflective properties of the medium are good, you can mount OPTISOUND 3030 C on a socket piece. You will find recommended values for socket heights in the following illustration. The socket end

should be smooth and burr-free, if possible also rounded. Carry out a false echo storage.

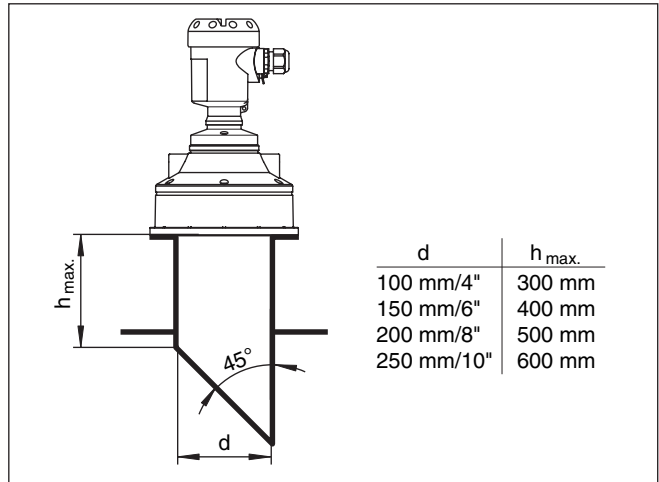

Fig. 7: Deviating socket dimensions

Sensor orientation

In liquids, direct the sensor as perpendicular as possible to the product surface to achieve optimum measurement results.

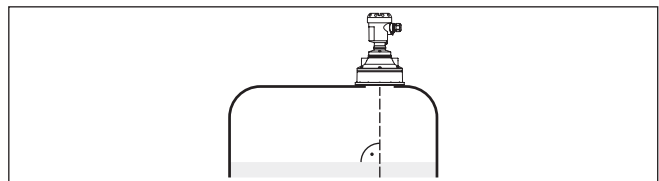

Fig. 8: Alignment in liquids

To optimally align the sensor to solid products, a swivelling holder (mounting strap) can be implemented.

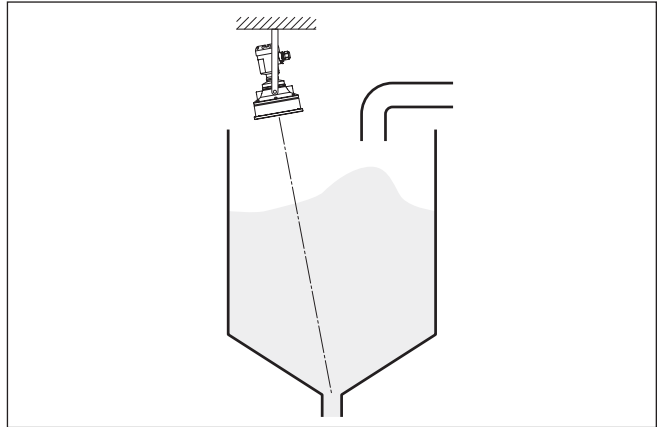

Fig. 9: Orientation in solids

To reduce the min. distance to the medium, you can also mount OP-TISOUND 3030 C with a beam deflector. By doing this, it is possible to fill the vessel nearly to maximum. Such an arrangement is suitable primarily for open vessels such as e.g. overflow basins.

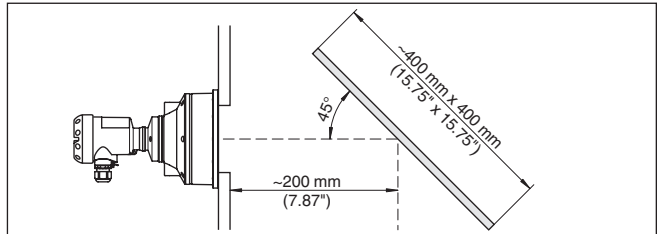

Fig. 10: Beam deflector

Vessel installations

The ultrasonic sensor should be installed at a location where no installations cross the ultrasonic beam.

Vessel installations such as for example, ladders, limit switches, heating spirals, struts etc. can cause false echoes that interfere with the useful echo. Make sure when planning your measuring site that the ultrasonic signals have a "clear view" to the measured product.

In case of existing vessel installations, a false echo storage should be carried out during setup.

If large vessel installations such as struts or supports cause false echoes, these can be attenuated through supplementary measures. Small, inclined sheet metal or plastic baffles above the installations scatter the ultrasonic signals and avoid direct false echoes.

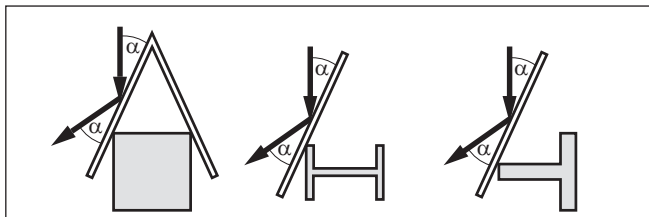

Fig. 11: Cover flat, large-area profiles with deflectors

Agitators

If there are agitators in the vessel, a false signal storage should be carried out with the agitators in motion. This ensures that the interfering reflections from the agitators are saved with the blades in different positions.

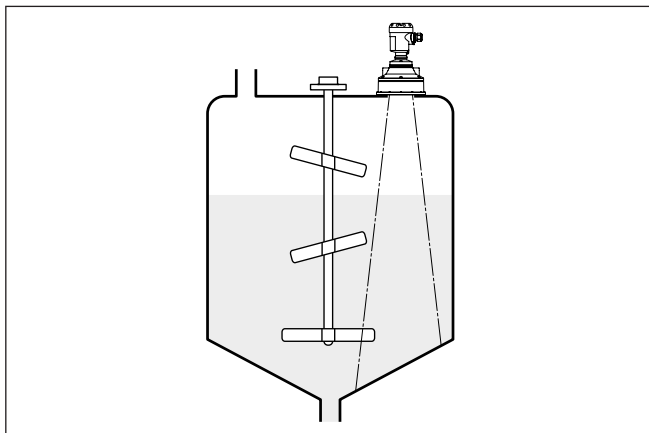

Fig. 12: Agitators

Inflowing medium

Do not mount the instruments in or above the filling stream. Make sure that you detect the product surface, not the inflowing product.

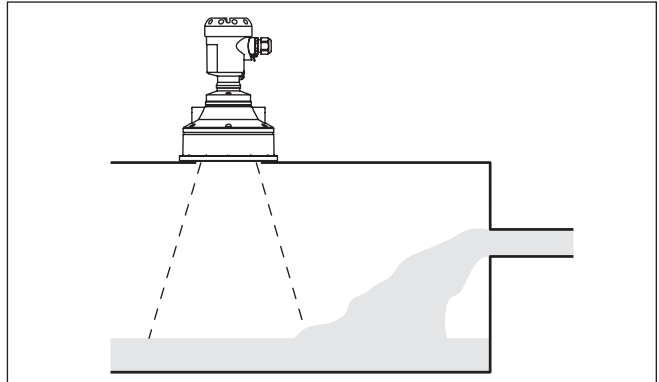

Fig. 13: Inflowing liquid

Foam

Through the action of filling, stirring and other processes in the vessel, dense foams which considerably damp the emitted signals may form on the product surface.

If foams are causing measurement errors, the sensor should be used in a standpipe or, alternatively, the more suitable guided radar sensors (TDR) should be used.

Guided wave radar is unaffected by foam generation and is particularly suitable for such applications.

Air turbulences

If there are strong air currents in the vessel, e.g. due to strong winds in outdoor installations or air turbulence, e.g. by cyclone extraction you should mount OPTISOUND 3030 C in a standpipe or use a different measuring principle, e.g. radar or guided radar (TDR).

Standpipe measurement

By using a standpipe (surge or bypass tube), the influence of vessel installations, foam generation and turbulence is excluded.

Standpipes must extend all the way down to the requested min. level, as measurement is only possible within the tube.

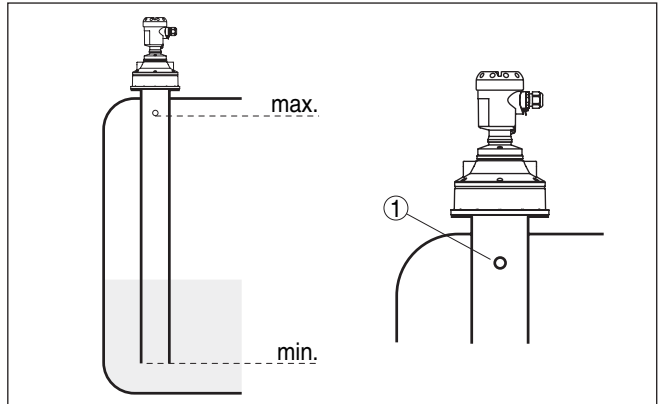

Fig. 14: Standpipe in the tank

1 Vent hole $\varnothing 5 \dots 10 \text{ mm}$

OPTISOUND 3030 C can be used from tube diameters of 100 mm.
Avoid large gaps and thick welding joints when connecting the tubes.
Generally carry out a false echo storage.

Measurement in a standpipe is not recommended for extremely adhesive products.

5 Connecting to power supply

5.1 Preparing the connection

Note safety instructions

Always keep in mind the following safety instructions:

- Connect only in the complete absence of line voltage
- If voltage surges are expected, overvoltage arresters should be installed according to Profibus specifications

Take note of safety instructions for Ex applications



In hazardous areas you must take note of the respective regulations, conformity and type approval certificates of the sensors and power supply units.

Voltage supply

Power supply is provided by a Profibus DP/PA segment coupler. The power supply range can differ depending on the instrument version. The data for power supply are specified in chapter "*Technical data*".

Connection cable

Connection is made with screened cable according to the Profibus specification. Power supply and digital bus signal are carried over the same two-wire connection cable.

Use cable with round cross-section. A cable outer diameter of 5 ... 9 mm (0.2 ... 0.35 in) ensures the seal effect of the cable gland. If you are using cable with a different diameter or cross-section, exchange the seal or use a suitable cable gland.

Please make sure that your installation is carried out according to the Profibus specification. In particular, make sure that the termination of the bus is done with appropriate terminating resistors.

Cable gland ½ NPT

On the instrument with cable entry ½ NPT and plastic housing there is a metallic ½" threaded insert moulded into the plastic housing.



Caution:

No grease should be used when screwing the NPT cable gland or steel tube into the threaded insert. Standard grease can contain additives that corrode the connection between threaded insert and housing. This would influence the stability of the connection and the tightness of the housing.

Cable screening and grounding

In systems with potential equalisation, connect the cable screen directly to ground potential at the power supply unit, in the connection box and at the sensor. The screen in the sensor must be connected directly to the internal ground terminal. The ground terminal outside on the housing must be connected to the potential equalisation (low impedance).

In systems without potential equalisation, connect the cable screen directly to ground potential at the power supply unit and at the sensor. In the connection box or T-distributor, the screen of the short stub to the sensor must not be connected to ground potential or to another cable screen. The cable screens to the power supply unit and to the next distributor must be connected to each other and also connected to ground potential via a ceramic capacitor (e.g. 1 nF, 1500 V). The low frequency potential equalisation currents are thus suppressed,

but the protective effect against high frequency interference signals remains.



The total capacitance of the cable and of all capacitors must not exceed 10 nF in Ex applications.

Connection cable for Ex applications



Take note of the corresponding installation regulations for Ex applications. In particular, make sure that no potential equalisation currents flow over the cable screen. In case of grounding on both sides this can be achieved by the use of a capacitor or a separate potential equalisation.

5.2 Connection procedure

Proceed as follows:

1. Unscrew the housing lid
 2. If a display and adjustment module is installed, remove it by turning it slightly to the left.
 3. Loosen compression nut of the cable entry gland
 4. Remove approx. 10 cm (4 in) of the cable mantle, strip approx. 1 cm (0.4 in) of insulation from the ends of the individual wires
 5. Insert the cable into the sensor through the cable entry
 6. Lift the opening levers of the terminals with a screwdriver (see following illustration)
 7. Insert the wire ends into the open terminals according to the wiring plan
 8. Press down the opening levers of the terminals, you will hear the terminal spring closing
 9. Check the hold of the wires in the terminals by lightly pulling on them
 10. Connect the screen to the internal ground terminal, connect the outer ground terminal to potential equalisation
 11. Tighten the compression nut of the cable entry gland. The seal ring must completely encircle the cable
 12. Screw the housing lid back on
- The electrical connection is finished.

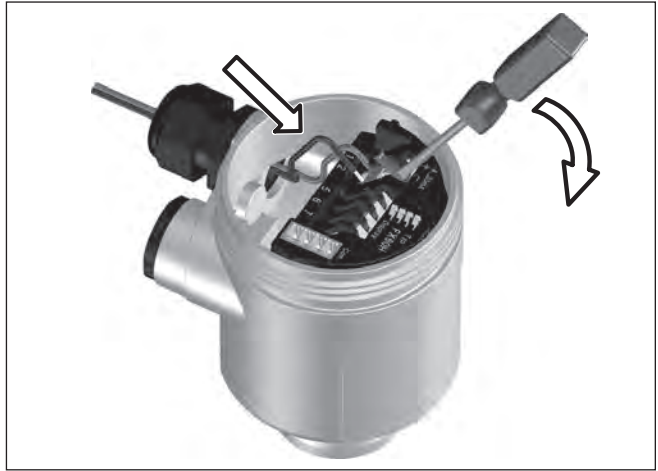

Fig. 15: Connection steps 6 and 7

Housing overview

5.3 Wiring plan, single chamber housing

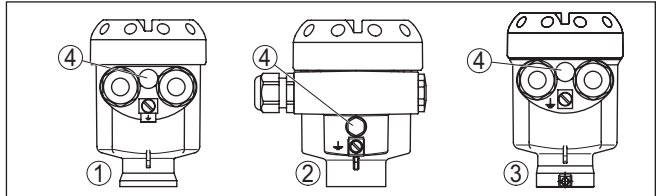
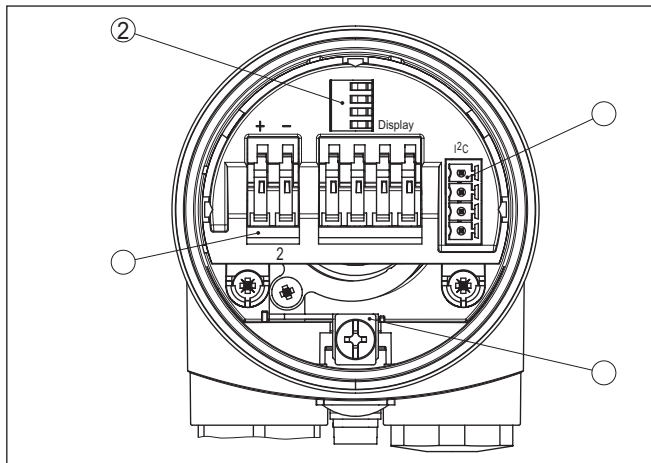

Fig. 16: Material versions, single chamber housing

- 1 Plastic
- 2 Aluminium
- 3 Stainless steel
- 4 Filter element for air pressure compensation

Electronics and terminal compartment



- 1 Spring-loaded terminals for voltage supply
- 2 Spring loaded terminals for display and adjustment module
- 3 Plug connector for service interface
- 4 Ground terminal for connection of the cable screen

Wiring plan

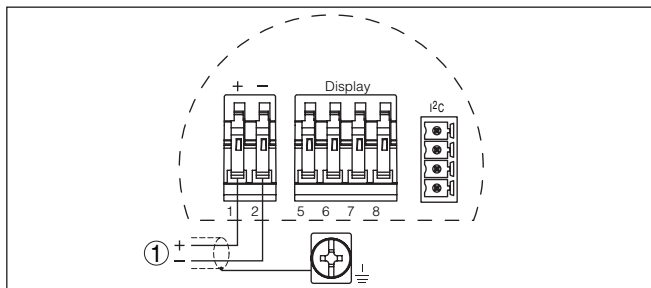

Fig. 18: Wiring plan, single chamber housing

- 1 Voltage supply, signal output

5.4 Wiring plan, double chamber housing

Housing overview

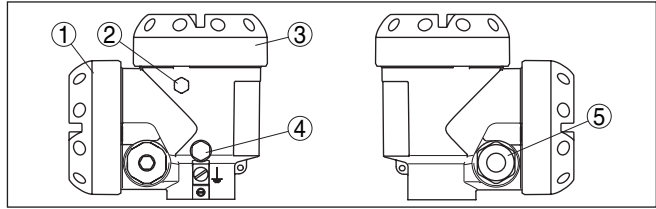

Fig. 19: Double chamber housing

- 1 Housing cover, connection compartment
- 2 Blind plug
- 3 Housing cover, electronics compartment
- 4 Filter element for air pressure compensation
- 5 Cable gland

Electronics compartment

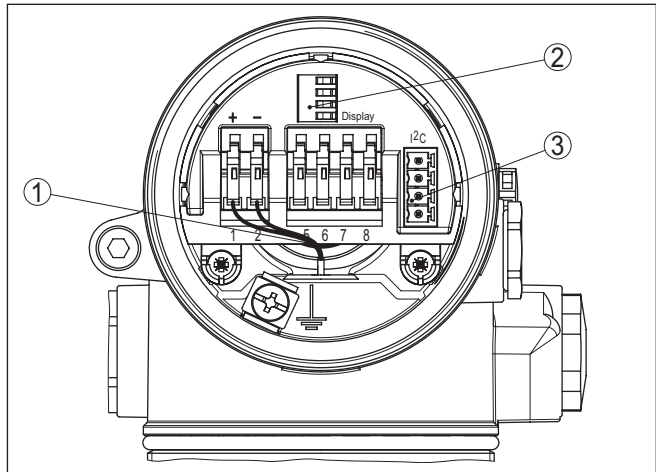

Fig. 20: Electronics compartment, double chamber housing

- 1 Internal connection cable to the connection compartment
- 2 Spring loaded terminals for display and adjustment module
- 3 Plug connector for service interface

Terminal compartment

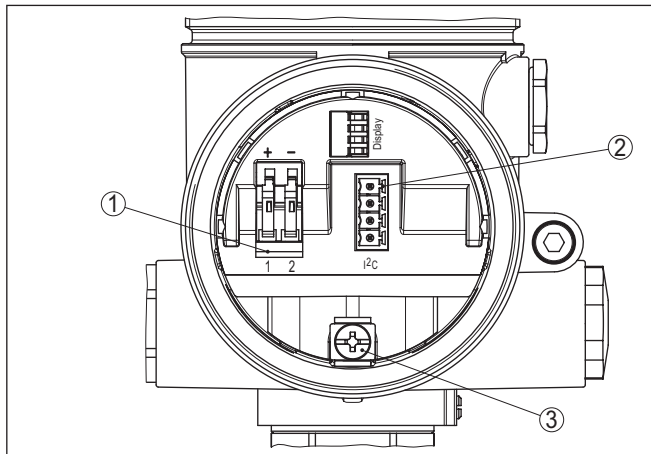

Fig. 21: Terminal compartment, double chamber housing

- 1 Spring-loaded terminals for voltage supply
- 2 Plug connector for service interface
- 3 Ground terminal for connection of the cable screen

Wiring plan

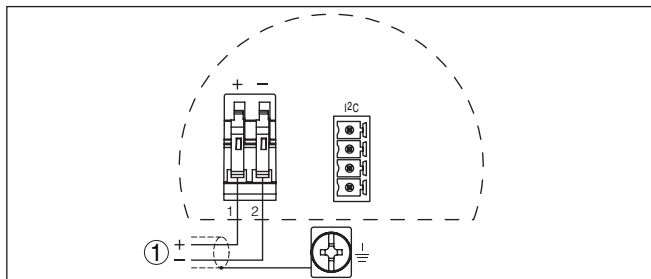

Fig. 22: Wiring plan, double chamber housing

- 1 Voltage supply, signal output

5.5 Switch-on phase

Switch-on phase

After connecting OPTISOUND 3030 C to power supply or after a voltage recurrence, the instrument carries out a self-check for approx. 30 seconds:

- Internal check of the electronics
- Indication of the instrument type, the firmware as well as the sensor TAGs (sensor designation)
- Output signal jumps briefly (approx. 10 seconds) to the set fault current

Then the corresponding current is outputted to the cable (the value corresponds to the actual level as well as the settings already carried out, e.g. factory setting).

6 Set up with the display and adjustment module

6.1 Insert display and adjustment module

The display and adjustment module can be inserted into the sensor and removed again at any time. It is not necessary to interrupt the power supply.

Proceed as follows for mounting the display and adjustment module:

1. Unscrew the housing lid
2. Place the display and adjustment module in the desired position on the electronics (you can choose any one of four different positions - each displaced by 90°)
3. Press the display and adjustment module onto the electronics and turn it to the right until it snaps in
4. Screw housing lid with inspection window tightly back on

Disassembly is carried out in reverse order.

The display and adjustment module is powered by the sensor, an additional connection is not necessary.



Fig. 23: Insert display and adjustment module



Note:

If you intend to retrofit the instrument with a display and adjustment module for continuous measured value indication, a higher lid with an inspection glass is required.

6.2 Adjustment system

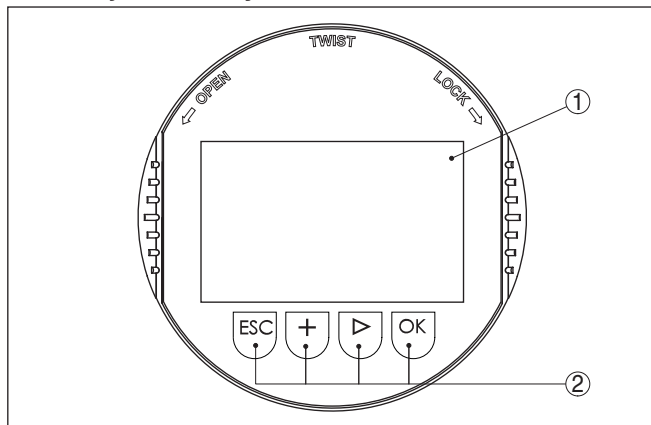

Fig. 24: Display and adjustment elements

- 1 LC display
- 2 Indication of the menu item number
- 3 Adjustment keys

Key functions

- **[OK]** key:
 - Move to the menu overview
 - Confirm selected menu
 - Edit parameter
 - Save value
- **[>]** key to select:
 - Menu change
 - Select list entry
 - Select editing position
- **[+]** key:
 - Change value of the parameter
- **[ESC]** key:
 - Interrupt input
 - Jump to next higher menu

Adjustment system

You adjust the instrument via the four keys of the display and adjustment module. The individual menu items are shown on the LC display. You can find the functions of the individual keys in the previous illustration.

Time functions

By pushing the **[+]** and **[>]** keys once, the edited value or the cursor changes by one position. By pushing the keys longer than 1 s the change will be continuously.

By pushing the **[OK]** and **[ESC]** keys simultaneously for more than 5 s, a return to the basic menu is caused. The menu language is then switched over to "English".

Approx. 60 minutes after the last pressing of a key, an automatic reset to measured value indication is triggered. Any values not confirmed with **[OK]** will not be saved.

6.3 Setup steps

Address setting

Before starting the real parameter adjustment of a Profibus PA sensors, first of all the address setting must be carried out. A detailed description is available in the operating instructions manual of the display and adjustment module.

Address setting

Before starting the real parameter adjustment of a Profibus PA sensors, first of all the address setting must be carried out. A detailed description is available in the operating instructions manual of the display and adjustment module.

Basic adjustment - Sensor address

Level and pressure sensors operate as slaves on the Profibus PA. To be identified as a bus participant, each sensor must have a unique address. Each instrument is delivered with address 126. With this address, it can at first be connected to an existing bus. However, the address must be changed. This can be done in this menu item.

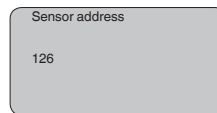

Parameter adjustment

The sensor measures the distance from the sensor to the product surface. For indication of the real level, an allocation of the measured distance to the percentage height must be carried out.

The actual level is then calculated on the basis of these entered values. At the same time, the operating range of the sensor is limited from maximum range to the requested range.

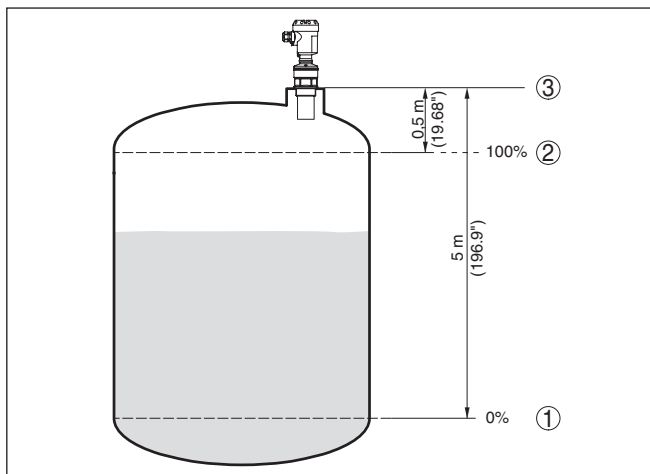

Fig. 25: Parameter adjustment example min./max. adjustment

- 1 Min. level = max. measuring distance
- 2 Max. level = min. measuring distance

The real product level during this adjustment is not important, because the min./max. adjustment is always carried out without changing the product level. These settings can be made ahead of time without the instrument having to be installed.

Basic adjustment - Min. adjustment

Proceed as follows:

1. Move from the measured value display to the main menu by pushing **[OK]**.

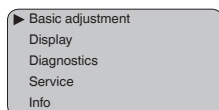

2. Select the menu item "Basic adjustment" with **[->]** and confirm with **[OK]**. Now the menu item "Min. adjustment" is displayed.

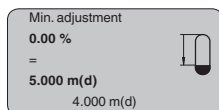

3. Prepare the % value for editing with **[OK]** and set the cursor to the requested position with **[->]**. Set the requested percentage value with **[+]** and save with **[OK]**. The cursor jumps now to the distance value.
4. Enter the suitable distance value in m for the empty vessel (e.g. distance from the sensor to the vessel bottom) corresponding to the percentage value.
5. Save the settings with **[OK]** and move to "Max. adjustment" with **[->]**.

Basic adjustment - Max. adjustment

Proceed as follows:

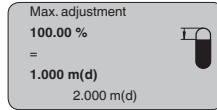

1. Prepare the % value for editing with **[OK]** and set the cursor to the requested position with **[->]**. Set the requested percentage value with **[+]** and save with **[OK]**. The cursor jumps now to the distance value.
2. Enter the appropriate distance value in m (corresponding to the percentage value) for the full vessel. Keep in mind that the max. level must lie below the dead band.
3. Save the settings with **[OK]** and move to "Medium selection" with **[->]**.

Basic adjustment - Medium

Each product has different reflective properties. In addition, there are various interfering factors which have to be taken into account: agitated product surfaces and foam generation (with liquids); dust generation, material cones and echoes from the vessel wall (with solids). To adapt the sensor to these different conditions, you should first select "Liquid" or "Solid".

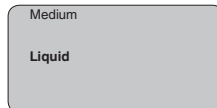

With solids, you can also choose between "Powder/Dust", "Granular/Pellets" or "Ballast/Pebbels".

Through this additional selection, the sensor is adapted perfectly to the product and measurement reliability, particularly in products with poor reflective properties, is considerably increased.

Enter the requested parameters via the appropriate keys, save your settings and jump to the next menu item with the **[->]** key.

Basic adjustment - Vessel form

Apart from the medium, the vessel shape can also influence the measurement. To adapt the sensor to these measuring conditions, this menu item offers different options depending on whether liquid or bulk solid is selected. With "Liquids" these are "Storage tank", "Stilling tube", "Open vessel" or "Stirred vessel", with "Solid", "Silo" or "Bunker".

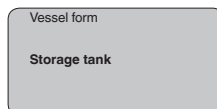

Enter the requested parameters via the appropriate keys, save your settings and jump to the next menu item with the **[->]** key.

Basic adjustment - Damp- ing

To suppress fluctuations in the measured value display, e. g. caused by an agitated product surface, a damping can be set. This time can

be between 0 and 999 seconds. Keep in mind that the reaction time of the entire measurement will then be longer and the sensor will react to measured value changes with a delay. In general, a period of a few seconds is sufficient to smooth the measured value display.

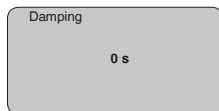

Enter the requested parameters via the appropriate keys, save your settings and jump to the next menu item with the **[->]** key.

Basic adjustment - Linearization curve

A linearisation is necessary for all vessels in which the vessel volume does not increase linearly with the level - e.g. in a horizontal cylindrical or spherical tank - and the indication or output of the volume is required. Corresponding linearisation curves are preprogrammed for these vessels. They represent the correlation between the level percentage and vessel volume. By activating the appropriate curve, the volume percentage of the vessel is displayed correctly. If the volume should not be displayed in percent but e.g. in l or kg, a scaling can be also set in the menu item "Display".

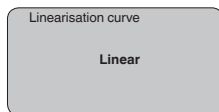

Enter the requested parameters via the appropriate keys, save your settings and jump to the next menu item with the **[->]** key.

Basic adjustment - Channel

The channel is the input selector switch for function block (FB) of the sensor. Within the function block, additional scalings (Out-Scale) are carried out. In this menu item, the value for the function block is selected:

- SV1 (Secondary Value 1):
 - Percent with radar, guided microwave and ultrasonic sensors
 - Pressure or height with pressure transmitters
- SV2 (Secondary Value 2):
 - Distance with radar, guided microwave and ultrasonic sensors
 - Percent with pressure transmitters
- PV (Primary Value):
 - Linearised percentage value

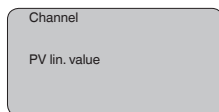

Basic adjustment - Sensor TAG

In this menu item you can enter an unambiguous designation for the sensor, e.g. the measurement loop name or the tank or product designation. In digital systems and in the documentation of larger plants, a singular designation should be entered for exact identification of individual measuring points.



With this menu item, the Basic adjustment is finished and you can now jump to the main menu with the **[ESC]** key.

Menu section, display

Display - Displayed value

Radar, guided microwave and ultrasonic sensors deliver the following measured values:

- SV1 (Secondary Value 1): Percentage value after the adjustment
- SV2 (Secondary Value 2): Distance value before the adjustment
- PV (Primary Value): Linearised percentage value
- PA-Out (value after passing the function block): PA output

A pressure transmitter delivers the following measured values:

- SV1 (Secondary Value 1): Pressure or height value before adjustment
- SV2 (Secondary Value 2): Percentage value after the adjustment
- PV (Primary Value): Linearised percentage value
- PA-Out (value after passing the function block): PA output
- Temperature

In the menu item "*Display*" you can define which value should be indicated on the display.

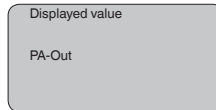

Display - Backlight

A background lighting integrated by default can be adjusted via the adjustment menu. The function depends on the height of the supply voltage. See "*Technical data/Voltage supply*".



In the default setting, the lightning is switched off.

Diagnosis - Peak value

The respective min. and max. measured values are saved in the sensor. The values are displayed in the menu item "*Peak values*".

- Min. and max. distance in m(d)
- Min. and max. temperature

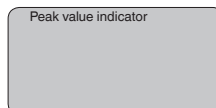

Diagnosis - Measurement reliability

When non-contact level sensors are used, the measurement can be influenced by the respective process conditions. In this menu item, the measurement reliability of the level echo is displayed as dB value. The measurement reliability equals signal strength minus noise. The higher the value, the more reliable the measurement. With a functioning measurement, the values are > 10 dB.

Diagnostics - Device status

The instrument status is displayed in this menu item. If no failure is detected by the sensor, "OK" will be displayed. If a failure is detected, there will be a sensor-specific flashing fault signal, for example "E013". The failure is also displayed in clear text, for example "No measured value available".



Information:

The fault message as well as the clear text indication are also carried out in the measured value display.

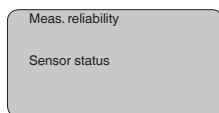

Diagnosis - Curve selection

With ultrasonic sensors, the "**Echo curve**" represents the signal strength of the echoes over the measuring range. The unit of signal strength is "dB". The signal strength enables the judgement of the quality of the measurement.

The "**False echo curve**" displays the saved false echoes (see menu "Service") of the empty vessel as signal strength in "dB" over the measuring range.

Up to 3000 measured values are recorded (depending on the sensor) when starting a "**Trend curve**". Then the values can be displayed on a time axis. The oldest measured values are always deleted.

In the menu item "*Choose curve*", the respective curve is selected.

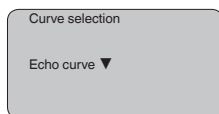

Information:

The trend recording is not activated when being shipped. It must be started by the user via the menu item "*Start trend curve*".

Diagnosis - Curve presentation

A comparison of the echo curve and the false echo curve allows a more detailed evaluation of measurement reliability. The selected curve is updated continuously. With the [OK] key, a submenu with zoom functions is opened.

The following functions are available with "**Echo and false echo curve**":

- "X-Zoom": Zoom function for the meas. distance

- "Y-Zoom": 1, 2, 5 and 10x signal magnification in "dB"
- "Unzoom": Reset the presentation to the nominal measuring range without magnification

In the menu item "**Trend curve**" the following are available:

- "X-Zoom": Resolution
 - 1 minute
 - 1 hour
 - 1 day
- "Stop/Start": Interrupt a recording or start a new recording
- "Unzoom": Reset the resolution to minutes

As default setting, the recording pattern has 1 minute. With the adjustment software PACTware, this pattern can be also set to 1 hour or 1 day.

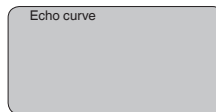

Service - False signal suppression

High sockets: or vessel installations, such as e. g. struts or agitators as well as buildup and weld joints on the vessel walls, cause interfering reflections which can impair the measurement. A false echo storage detects and marks these false echoes, so that they are no longer taken into account for the level measurement. A false echo memory should be created with low level so that all potential interfering reflections can be detected.

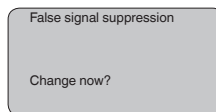

Proceed as follows:

1. Move from the measured value display to the main menu by pushing **[OK]**.
2. Select the menu item "Service" with **[->]** and confirm with **[OK]**. Now the menu item "False signal suppression" is displayed.
3. Confirm "False signal suppression - Change now" with **[OK]** and select in the below menu "Create new". Enter the actual distance from the sensor to the product surface. All false signals in this area are detected by the sensor and saved after confirming with **[OK]**.



Note:

Check the distance to the product surface, because if an incorrect (too large) value is entered, the existing level will be saved as a false signal. The level would then no longer be detectable in this area.

Service - Extended setting

The menu item "Extended setting" offers the possibility to optimise OPTISOUND 3030 C for applications in which the level changes very quickly. To do this, select the function "Quick level change > 1 m/min."



Extended setting

quick level change > 1 m/min.



Note:

Since with the function "Quick level change > 1 m/min." the generation of an average value of the signal processing is considerably reduced, false reflections by agitators or vessel installations can cause measured value fluctuations. A false echo memory is thus recommended.

Service - Additional PA value

Profibus transmits two values cyclically. The first value is determined in the menu item "Channel". The selection of the additional cyclical value is made in the menu item "Additional PA value".

The following values are available with radar, guided microwave and ultrasonic sensors:

- SV1 (Secondary Value 1): Percentage value after the adjustment
- SV2 (Secondary Value 2): Distance value before the adjustment
- PV (Primary Value): Linearised percentage value

With pressure transmitters the following values are available:

- SV1 (Secondary Value 1): Pressure or height value before adjustment
- SV2 (Secondary Value 2): Percentage value after the adjustment
- PV (Primary Value): Linearised percentage value



Additional PA value

Service - Determine Out-Scale

Here, you determine the unit and scaling for PA-Out. These settings also apply to the values displayed on the display and adjustment module if in the menu item "Displayed value" PA-Out was selected.

The following displayed values are available in "Out-Scale unit":

- Pressure (only with pressure transmitters)
- Height
- Ground
- Flow
- Volume
- Others (no unit, %, mA)

In the menu item "PV-Out-Scale", the requested numerical value with decimal point is entered for 0 % and 100 % of the measured value.



Out-Scale-Unit

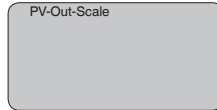

Service - Simulation

In this menu item you simulate a user-defined level or pressure value via the current output. This allows you to test the signal path, e.g. through connected indicating instruments or the input card of the control system.

The following simulation variables are available:

- Percent
- Current
- Pressure (with pressure transmitters)
- Distance (with radar and guided microwave)

With Profibus PA sensors, the selection of the simulated value is made via the "Channel" in the menu "*Basic adjustments*".

How to start the simulation:

1. Push **[OK]**
2. Select the requested simulation variable with **[>]** and confirm with **[OK]**.
3. Set the requested numerical value with **[+]** and **[>]**.
4. Push **[OK]**

The simulation is now running, with 4 ... 20 mA/HART a current is outputted and with Profibus PA or Foundation Fieldbus a digital value.

How to interrupt the simulation:

→ Push **[ESC]**



Information:

The simulation is automatically terminated 10 minutes after the last pressing of a key.

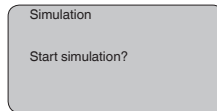

Service - Reset

With the reset function, modified values are reset. Three subfunctions are available:

- Basic adjustment
 - Reset the values modified with the display and adjustment module to the sensor-specific basic setting
- Default setting
 - As basic adjustment, but also reset of special parameters to the default values¹⁾
- Peak values measured value and temperature²⁾

¹⁾ Special parameters are parameters which are set customer-specifically on the service level with the adjustment software PACTware.

²⁾ Temperature only with pressure transmitters and ultrasonic sensors.

- Reset of the min./max. values of pressure, level and temperature to the current values



Information:

Because the reset values are nearly sensor-specific, they are listed in the operating instructions manual of the respective sensor.

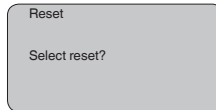

Service - Adjustment unit In this menu item you select the internal arithmetic unit of the sensor.

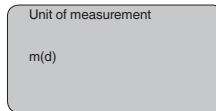

Service - Language The sensor is already set to the ordered national language. In this menu item you can change the language. The following languages are available, e.g. in software version 3.50:

- Deutsch
- English
- Français
- Español
- Pycckuu
- Italiano
- Netherlands
- Japanese
- Chinese

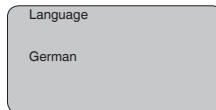

Service - Copy sensor data

This function enables reading out parameter adjustment data as well as writing parameter adjustment data into the sensor via the display and adjustment module. A description of the function is available in the operating instructions manual "*Display and adjustment module*".

The following data are read out or written with this function:

- Measured value presentation
- Adjustment
- Medium
- Vessel form
- Damping
- Linearisation curve
- Sensor-TAG
- Displayed value
- Display unit
- Scaling

- Current output
- Unit of measurement
- Language

The following safety-relevant data are **not** read out or written:

- HART mode
- PIN

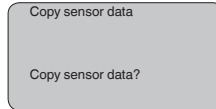

Service - PIN

In this menu item, the PIN is activated/deactivated permanently. Entering a 4-digit PIN protects the sensor data against unauthorized access and unintentional modifications. If the PIN is activated permanently, it can be deactivated temporarily (i.e. for approx. 60 min.) in any menu item. The instrument is delivered with the PIN set to 0000.

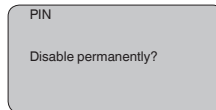

Only the following functions are permitted with activated PIN:

- Select menu items and show data
- Read data from the sensor into the display and adjustment module.

Info

In this menu item the most important sensor information can be displayed:

- Instrument type
- Serial number: 8-digit number, e.g. 12345678

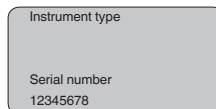

- Date of manufacture: Date of the factory calibration, e.g. 24. March 2015
- Software version: Edition of the sensor software, e.g. 3.80

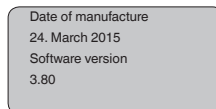

- Date of last change using PC: Date of the last change of sensor parameters via PC

Last change using PC

- Sensor details, e.g. approval, process fitting, seal, measuring cell, measuring range, electronics, housing, cable entry, plug, cable length etc.

Sensor characteristics
Display now?

6.4 Menu schematic



Information:

Depending on the version and application, the highlighted menu windows may not always be available.

Basic adjustment

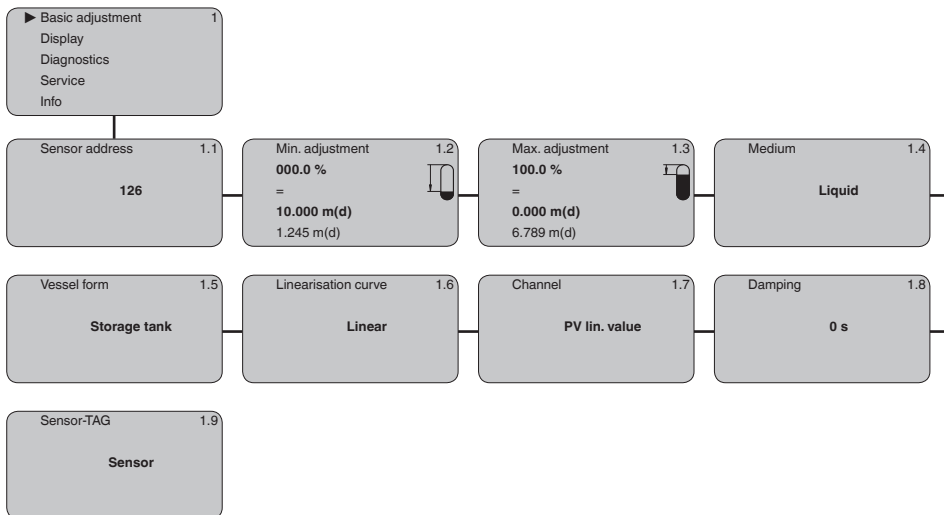

Display

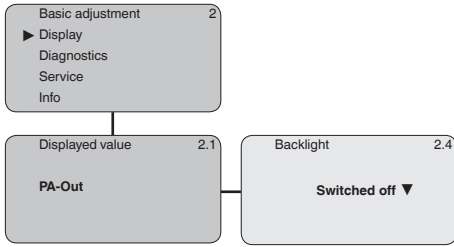

Diagnostics

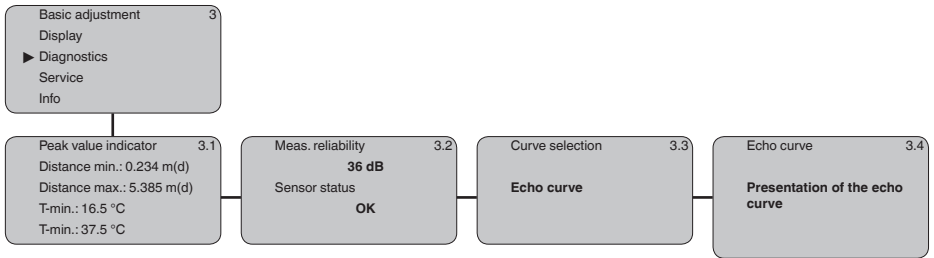

Service

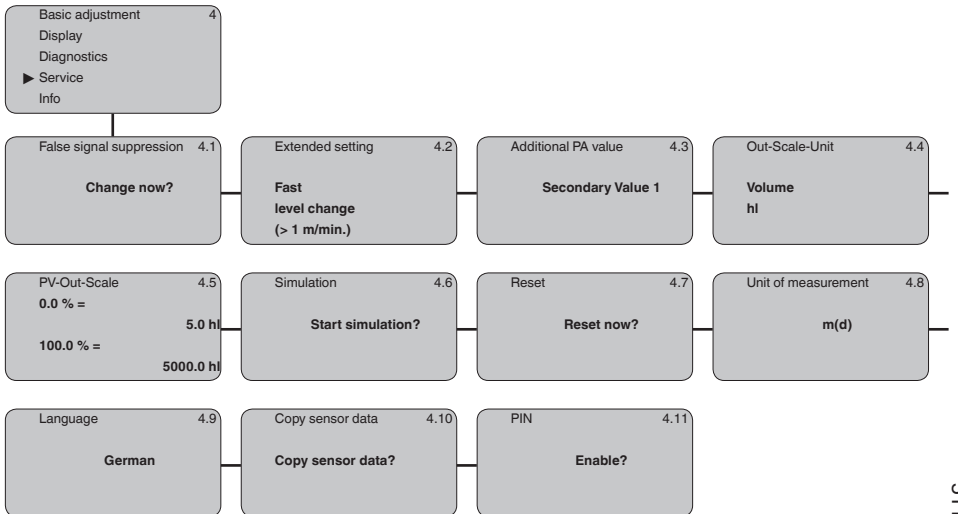

Info

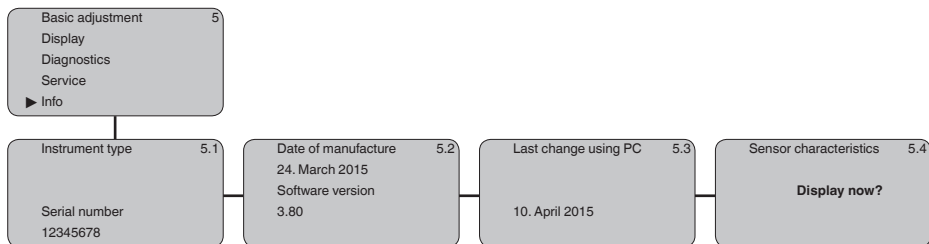

6.9 Saving the parameter adjustment data

We recommend noting the adjusted data, e.g. in this operating instructions manual, and archiving them afterwards. They are thus available for multiple use or service purposes.

If OPTISOUND 3030 C is equipped with a display and adjustment module, the most important data can be read out of the sensor into the display and adjustment module. The procedure is described in the operating instructions manual "*Display and adjustment module*" in the menu item "*Copy sensor data*". The data remain there permanently even if the sensor power supply fails.

If it is necessary to exchange the sensor, the display and adjustment module is inserted into the replacement instrument and the data are written into the sensor under the menu item "*Copy sensor data*".

7 Maintenance and fault rectification

7.1 Maintenance

If the instrument is used properly, no special maintenance is required in normal operation.

7.2 Rectify faults

The operator of the system is responsible for taking suitable measures to rectify faults.

Reaction when malfunction occurs

Causes of malfunction

OPTISOUND 3030 C offers maximum reliability. Nevertheless, faults can occur during operation. These may be caused by the following, e.g.:

- Sensor
- Process
- Voltage supply
- Signal processing

Fault rectification

The first measures to be taken are to check the output signal and evaluate fault messages via the display/adjustment module. The procedure is described below.

Error messages via the display and adjustment module

Error	Cause	Rectification
E013	no measured value available	Sensor in boot phase Sensor does not find an echo, e.g. due to faulty installation or wrong parameter adjustment
E017	Adjustment span too small	Carry out a fresh adjustment and increase the distance between min. and max. adjustment
E036	no operable sensor software	Carry out a software update or send instrument for repair
E041	Hardware error, electronics defective	Exchange the instrument or send it in for repair

Reaction after fault rectification

Depending on the reason for the fault and the measures taken, the steps described in chapter "Set up" may have to be carried out again.

7.3 Exchanging the electronics module

If the electronics module is defective, it can be replaced by the user.



In Ex applications, only instruments and electronics modules with appropriate Ex approval may be used.

If there is no electronics module available on site, one can be ordered from the Krohne agency serving you.

7.4 Instrument repair

If a repair is necessary, please proceed as follows:

On our homepage in the Internet under

<http://www.krohne-mar.com/fileadmin/>

[media-lounge/PDF-Download/Specimen_e.pdf](http://www.krohne-mar.com/fileadmin/media-lounge/PDF-Download/Specimen_e.pdf)

you can download a return form.

By doing this you help us carry out the repair quickly and without having to call back for needed information.

- Print and fill out one form per instrument
- Clean the instrument and pack it damage-proof
- Attach the completed form and possibly also a safety data sheet to the instrument

8 Dismount

8.1 Dismounting steps

**Warning:**

Before dismantling, be aware of dangerous process conditions such as e.g. pressure in the vessel or pipeline, high temperatures, corrosive or toxic products etc.

Take note of chapters "*Mounting*" and "*Connecting to power supply*" and carry out the listed steps in reverse order.

8.2 Disposal

The instrument consists of materials which can be recycled by specialised recycling companies. We use recyclable materials and have designed the parts to be easily separable.

WEEE directive 2002/96/EG

This instrument is not subject to the WEEE directive 2002/96/EG and the respective national laws. Pass the instrument directly on to a specialised recycling company and do not use the municipal collecting points. These may be used only for privately used products according to the WEEE directive.

Correct disposal avoids negative effects on humans and the environment and ensures recycling of useful raw materials.

Materials: see chapter "*Technical data*"

If you have no way to dispose of the old instrument properly, please contact us concerning return and disposal.

9 Supplement

9.1 Technical data

General data

Materials, wetted parts

– Process fitting	UP (glass-fibre reinforced polyester resin)
– Transducer diaphragm	316Ti
– Seal transducer diaphragm/process fitting	EPDM

Materials, non-wetted parts

– Mounting strap	1.4301
– Compression flange	PPH, 316L
– Housing	Plastic PBT (polyester), Alu die-casting, powder-coated, 316L
– Seal between housing and housing cover	NBR (stainless steel housing), silicone (Alu/plastic housing)
– Inspection window in housing cover	Polycarbonate
– Ground terminal	316Ti/316L

Weight	2.7 ... 5.7 kg (6 ... 12.6 lbs), depending on the process fitting and housing
--------	---

Output variable

Output signal	digital output signal, format according to IEEE-754
Cycle time	min. 1 s (dependent on the parameter setting)
Sensor address	126 (default setting)
Current value	10 mA, ± 0.5 mA
Damping (63 % of the input variable)	0 ... 999 s, adjustable
Met NAMUR recommendation	NE 43
Resolution, digital	> 1 mm (0.039 in)

Input variable

Measured variable	distance between lower edge of the transducer and product surface
Measuring range	
– Liquids	up to 15 m (49.21 ft)
– Bulk solids	up to 7 m (22.97 ft)
Dead zone	0.6 m (1.969 ft)

Reference conditions to measuring accuracy (according to DIN EN 60770-1)

Reference conditions according to DIN EN 61298-1

– Temperature	+18 ... +30 °C (+64 ... +86 °F)
– Relative humidity	45 ... 75 %
– Air pressure	860 ... 1060 mbar/86 ... 106 kPa (12.5 ... 15.4 psig)

Other reference conditions

- Reflector ideal reflector, e.g. metal plate 2 x 2 m (6.56 x 6.56 ft)
- False reflections Biggest false signal, 20 dB smaller than the useful signal

Measuring characteristics

Ultrasonic frequency	35 kHz
Interval	> 2 s (dependent on the parameter adjustment)
Abstrahlwinkel at -3 dB	6°
Adjustment time ³⁾	> 3 s (dependent on the parameter adjustment)

Measuring accuracy

Resolution, general	max. 1 mm
Deviation	see diagram

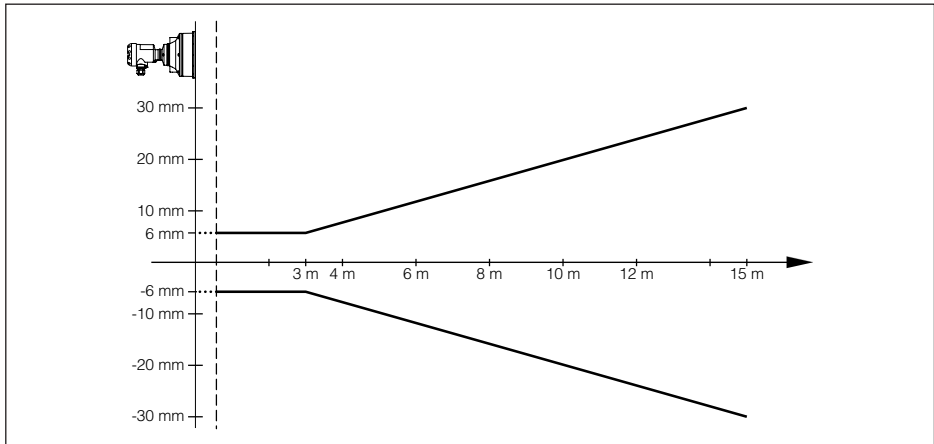

Fig. 26: Deviation OPTISOUND 3030 C

Influence of the ambient temperature to the sensor electronics⁴⁾

Average temperature coefficient of the zero signal (temperature error) 0.06 %/10 K

Ambient conditions

Ambient, storage and transport temperature -40 ... +80 °C (-40 ... +176 °F)

Process conditions

Process pressure
 - with compression flange -20 ... 100 kPa/-0.2 ... 1 bar (-2.9 ... 14.5 psi)

³⁾ Time to output the correct level (with max. 10 % deviation) after a sudden level change.

⁴⁾ Relating to the nominal measuring range.

– with mounting strap	0 kPa, since no seal possibility
Process temperature (transducer temperature)	-40 ... +80 °C (-40 ... +176 °F)
Vibration resistance	mechanical vibrations with 4 g and 5 ... 100 Hz ⁵⁾

Electromechanical data

Cable entry

– Single chamber housing	– 1 x cable gland M20 x 1.5 (cable: ø 5 ... 9 mm), 1 x blind plug M20 x 1.5 or: – 1 x closing cap ½ NPT, 1 x blind plug ½ NPT
– Double chamber housing	– 1 x cable gland M20 x 1.5 (cable: ø 5 ... 9 mm), 1 x blind plug M20 x 1.5 or: – 1 x closing cap ½ NPT, 1 x blind plug ½ NPT

Spring-loaded terminals for wire cross-section up to	2.5 mm ² (AWG 14)
--	------------------------------

Display and adjustment module

Voltage supply and data transmission	through the sensor
Indication	LC display in dot matrix
Adjustment elements	4 keys
Protection rating	
– unassembled	IP 20
– mounted into the sensor without cover	IP 40
Material	
– Housing	ABS
– Inspection window	Polyester foil

Voltage supply

Operating voltage	
– Non-Ex instrument	9 ... 32 V DC
– Ex ia instrument	9 ... 24 V DC
– Ex-d instrument	16 ... 32 V DC
Operating voltage with illuminated display and adjustment module	
– Non-Ex instrument	12 ... 32 V DC
– Ex ia instrument	12 ... 24 V DC
– Ex-d instrument	20 ... 32 V DC
Power supply by	DP/PA segment coupler
Max. number of sensors non-Ex/Ex	32/10

⁵⁾ Tested according to the guidelines of German Lloyd, GL directive 2.

Electrical protective measures

Protection rating

- Plastic housing IP 66/IP 67 (NEMA 4X)
- Aluminium and stainless steel housing IP 66/IP 68 (0.2 bar) NEMA 6P⁶⁾

Overvoltage category

III

Protection class

II

9.2 Profibus PA

Instrument master file

The instrument master file (GSD) contains the characteristic data of the Profibus PA instrument. These data are, e.g. the permissible transmission rates as well as information on diagnostics values and the format of the measured value outputted by the PA instrument.

A bitmap file is also provided for the Profibus network planning tool. This file is installed automatically when the GSD file is integrated. The bitmap file is used for symbolic indication of the PA instrument in the configuration tool.

Ident number

Each Profibus instrument gets an unambiguous ident number (ID number) from the Profibus user organisation (PNO). This ID number is also included in the name of the GSD file. For OPTISOUND 3030 C the ID number is **0x0770(hex)** and the GSD file "**SN_0770.GSD**". As an option to this manufacturer-specific GSD file, PNO provides also a general so-called profile-specific GSD file. For OPTISOUND 3030 C you have to use the general GSD file "**PA139701.GSD**". If the general GSD file is used, the sensor must be set to the profile-specific ident number via the DTM software. By default, the sensor operates with the manufacturer-specific ID number.



Note:

When using the profile-specific GSD file, the PA-OUT value as well as the temperature value are transmitted to the PLC (see block diagram "*Cyclical data traffic*").

Cyclical data traffic

The master class 1 (e.g. PLC) cyclically reads out measured values from the sensor during operation. The below block diagram below shows which data can be accessed by the PLC.

⁶⁾ A suitable cable is required for maintaining the protection rating.

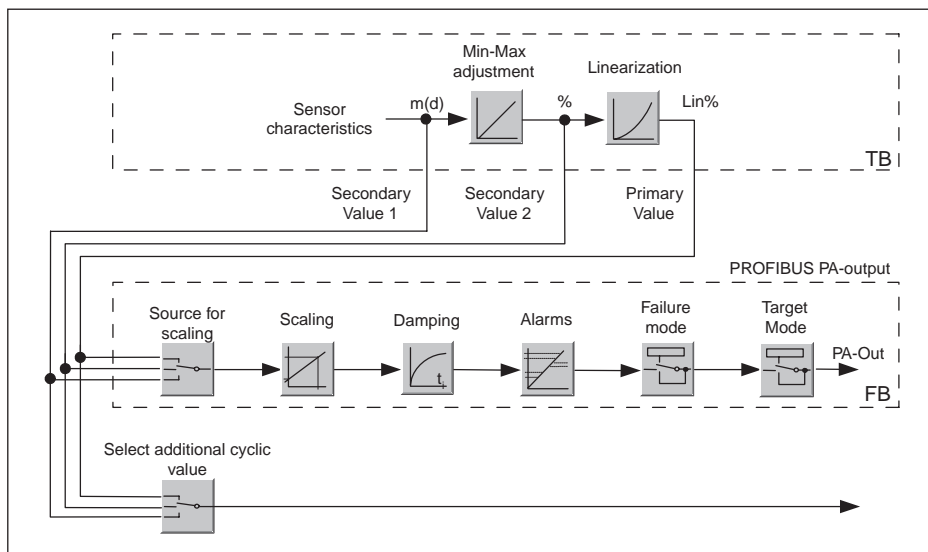

Fig. 27: OPTISOUND 3030 C: Block diagram with AI (PA-OUT) value and additional cyclical value

TB Transducer Block

FB Function Block

Module of the PA sensors

For the cyclic data traffic, OPTISOUND 3030 C provides the following modules:

- AI (PA-OUT)
 - PA-OUT value of the FB1 after scaling
- Temperature
 - PA-OUT value of the FB2 after scaling
- Additional Cyclic Value
 - Additional cyclical value (depending on the source)
- Free Place
 - This module must be used if a value in the data telegram of the cyclical data traffic should not be used (e.g. replacement of temperature and Additional Cyclic Value)

A maximum of three modules can be active. By means of the configuration software of the Profibus master you can determine the configuration of the cyclical data telegram with these modules. The procedure depends on the respective configuration software.



Note:

The modules are available in two versions:

- Short for Profibus master supporting only one "Identifier Format" byte, e.g. Allen Bradley
- Long for Profibus master only supporting the "Identifier Format" byte, e.g. Siemens S7-300/400

Examples of telegram configuration

In the following you will see how the modules can be combined and how the appendant data telegram is structured.

Example 1 (standard setting) with distance value, temperature value and additional cyclical value:

- AI (PA-OUT)
- Temperature
- Additional Cyclic Value

Byte-No.	1	2	3	4	5	6	7	8	9	10	11	12	13	14	15
Format	IEEE-754- Floating point value				Status	IEEE-754- Floating point value				Status	IEEE-754- Floating point value				Status
Value	PA-OUT (FB1)				Status (FB1)	Temperature (FB2)				Status (FB2)	Additional Cyclic Value				Status

Example 2 with distance value and temperature value without additional cyclical value:

- AI (PA-OUT)
- Temperature
- Free Place

Byte-No.	1	2	3	4	5	6	7	8	9	10
Format	IEEE-754- Floating point value				Status	IEEE-754- Floating point value				Status
Value	PA-OUT (FB1)				Status (FB1)	Temperature (FB2)				Status (FB2)

Example 3 with distance value and additional cyclical value without temperature value:

- AI (PA-OUT)
- Free Place
- Additional Cyclic Value

Telegram configuration:

Byte-No.	1	2	3	4	5	6	7	8	9	10
Format	IEEE-754- Floating point value				Status	IEEE-754- Floating point value				Status
Value	PA-OUT (FB1)				Status (FB1)	Additional Cyclic Value				Status

Data format of the output signal

Byte4	Byte3	Byte2	Byte1	Byte0
Status	Value (IEEE-754)			

Fig. 31: Data format of the output signal

The status byte corresponds to profile 3.0 "Profibus PA Profile for Process Control Devices" coded. The status "Measured value OK" is coded as 80 (hex) (Bit7 = 1, Bit6 ... 0 = 0).

The measured value is transferred as a 32 bit floating point number in the IEEE-754 format.

Byte n								Byte n+1								Byte n+2								Byte n+3							
Bit 7	Bit 6	Bit 5	Bit 4	Bit 3	Bit 2	Bit 1	Bit 0	Bit 7	Bit 6	Bit 5	Bit 4	Bit 3	Bit 2	Bit 1	Bit 0	Bit 7	Bit 6	Bit 5	Bit 4	Bit 3	Bit 2	Bit 1	Bit 0	Bit 7	Bit 6	Bit 5	Bit 4	Bit 3	Bit 2	Bit 1	Bit 0
VZ	2 ⁷	2 ⁶	2 ⁵	2 ⁴	2 ³	2 ²	2 ¹	2 ⁰	2 ⁻¹	2 ⁻²	2 ⁻³	2 ⁻⁴	2 ⁻⁵	2 ⁻⁶	2 ⁻⁷	2 ⁻⁸	2 ⁻⁹	2 ⁻¹⁰	2 ⁻¹¹	2 ⁻¹²	2 ⁻¹³	2 ⁻¹⁴	2 ⁻¹⁵	2 ⁻¹⁶	2 ⁻¹⁷	2 ⁻¹⁸	2 ⁻¹⁹	2 ⁻²⁰	2 ⁻²¹	2 ⁻²²	2 ⁻²³
Sign Bit	Exponent							Significant							Significant							Significant									

$$\text{Value} = (-1)^{VZ} \cdot 2^{(\text{Exponent} - 127)} \cdot (1 + \text{Significant})$$

Fig. 32: Data format of the measured value

Coding of the status byte associated with the PA output value

Status code	Description according to Profibus standard	Possible cause
0 x 00	bad - non-specific	Flash-Update active
0 x 04	bad - configuration error	<ul style="list-style-type: none"> - Adjustment error - Configuration error with PV-Scale (PV-Span too small) - Unit irregularity - Error in the linearization table
0 x 0C	bad - sensor failure	<ul style="list-style-type: none"> - Hardware error - Converter error - Leakage pulse error - Trigger error
0 x 10	bad - sensor failure	<ul style="list-style-type: none"> - Measured value generation error - Temperature measurement error
0 x 1f	bad - out of service constant	"Out of Service" mode switched on
0 x 44	uncertain - last unstable value	Failsafe replacement value (Failsafe-Mode = "Last value" and already valid measured value since switching on)
0 x 48	uncertain substitute set	<ul style="list-style-type: none"> - Switch on simulation - Failsafe replacement value (Failsafe-Mode = "Fsafe value")
0 x 4c	uncertain - initial value	Failsafe replacement value (Failsafe-Mode = "Last valid value" and no valid measured value since switching on)
0 x 51	uncertain - sensor; conversion not accurate - low limited	Sensor value < lower limit
0 x 52	uncertain - sensor; conversion not accurate - high limited	Sensor value > upper limit
0 x 80	good (non-cascade) - OK	OK
0 x 84	good (non-cascade) - active block alarm	Static revision (FB, TB) changed (10 sec. active, after the parameter of the static category has been written)
0 x 89	good (non-cascade) - active advisory alarm - low limited	Lo-Alarm
0 x 8a	good (non-cascade) - active advisory alarm - high limited	Hi-Alarm
0 x 8d	good (non-cascade) - active critical alarm - low limited	Lo-Lo-Alarm
0 x 8e	good (non-cascade) - active critical alarm - high limited	Hi-Hi-Alarm

9.3 Dimensions

Housing

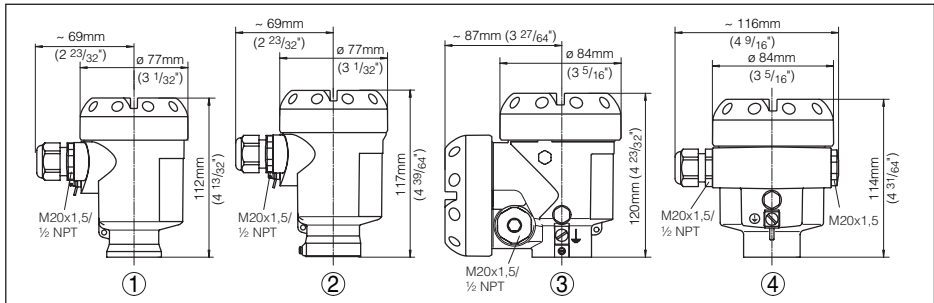

Fig. 33: Housing versions in protection rating IP 66/IP 67 and IP 66/IP 68, 0.2 bar (with integrated display and adjustment module the housing is 9 mm/0.35 in higher or wider)

- 1 Plastic housing
- 2 Stainless steel housing
- 3 Aluminium double chamber housing
- 4 Aluminium housing

OPTISOUND 3030 C

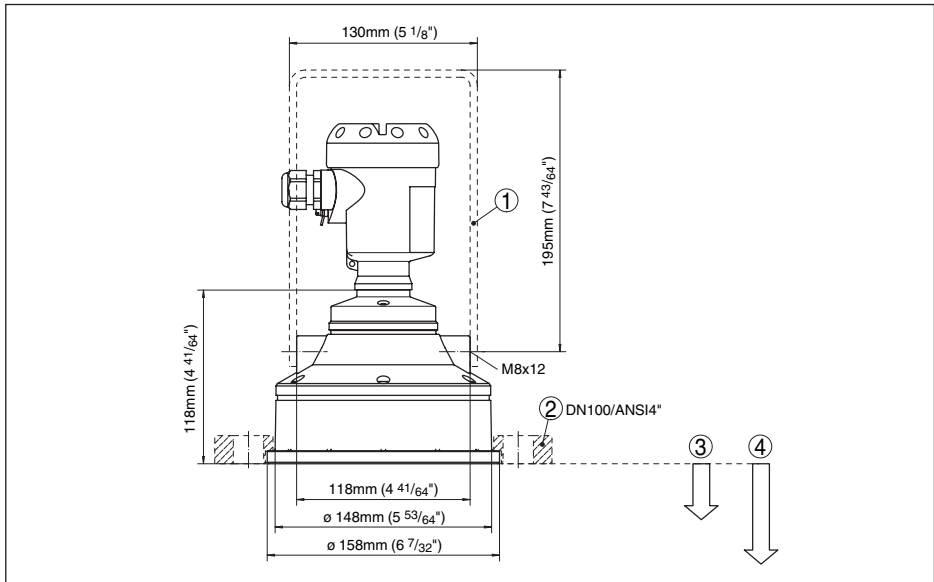

Fig. 34: OPTISOUND 3030 C

- 1 Mounting strap
- 2 Compression flange
- 3 Dead zone: 0.6 m (2 ft)
- 4 Measuring range: with liquids up to 15 m (49.21 ft), with solids up to 7 m (22.97 ft)

9.4 Trademark

All the brands as well as trade and company names used are property of their lawful proprietor/originator.



KROHNE product overview

- Electromagnetic flowmeters
- Variable area flowmeters
- Ultrasonic flowmeters
- Mass flowmeters
- Vortex flowmeters
- Flow controllers
- Level meters
- Temperature assemblies
- Pressure transmitters
- Analysis products
- Products and systems for the oil and gas industry

KROHNE Messtechnik GmbH & Co. KG
Ludwig-Krohne-Straße 5
D-47058 Duisburg
Tel.: +49 (0) 203 301 0
Tel.: +49 (0) 203 301 10389
info@krohne.de

The current list of all KROHNE contacts and addresses can be found at:
www.krohne.com

KROHNE