

OPTISWITCH 3100 C Handbook

Vibrating Level Switch

NAMUR



KROHNE

Contents

1	About this document	4
1.1	Function	4
1.2	Target group	4
1.3	Symbols used.....	4
2	For your safety	5
2.1	Authorised personnel	5
2.2	Appropriate use.....	5
2.3	Warning about incorrect use.....	5
2.4	General safety instructions	5
2.5	Safety label on the instrument	6
2.6	EU conformity.....	6
2.7	SIL conformity	6
2.8	Installation and operation in the USA and Canada	6
2.9	Safety instructions for Ex areas	6
3	Product description	7
3.1	Configuration.....	7
3.2	Principle of operation.....	7
3.3	Adjustment	8
3.4	Storage and transport.....	8
4	Mounting	10
4.1	General instructions	10
4.2	Mounting instructions	11
5	Connecting to power supply	15
5.1	Preparing the connection	15
5.2	Connection procedure.....	15
5.3	Wiring plan, single chamber housing.....	16
6	Setup	18
6.1	General information.....	18
6.2	Adjustment elements.....	18
6.3	Function table.....	19
6.4	Proof test (SIL)	20
7	Maintenance and fault rectification	22
7.1	Maintenance	22
7.2	Rectify faults.....	22
7.3	Exchanging the electronics module.....	23
7.4	How to proceed if a repair is necessary	24
8	Dismount	25
8.1	Dismounting steps.....	25
8.2	Disposal	25
9	Supplement	26
9.1	Technical data	26
9.2	Dimensions	29
9.3	Trademark	32

**Safety instructions for Ex areas**

Take note of the Ex specific safety instructions for Ex applications. These instructions are attached as documents to each instrument with Ex approval and are part of the operating instructions.

Editing status: 2018-11-22

1 About this document

1.1 Function

This instruction provides all the information you need for mounting, connection and setup as well as important instructions for maintenance, fault rectification, the exchange of parts and the safety of the user. Please read this information before putting the instrument into operation and keep this manual accessible in the immediate vicinity of the device.

1.2 Target group

This operating instructions manual is directed to trained personnel. The contents of this manual must be made available to the qualified personnel and implemented.

1.3 Symbols used



Information, note, tip: This symbol indicates helpful additional information and tips for successful work.



Note: This symbol indicates notes to prevent failures, malfunctions, damage to devices or plants.



Caution: Non-observance of the information marked with this symbol may result in personal injury.



Warning: Non-observance of the information marked with this symbol may result in serious or fatal personal injury.



Danger: Non-observance of the information marked with this symbol results in serious or fatal personal injury.



Ex applications

This symbol indicates special instructions for Ex applications.



List

The dot set in front indicates a list with no implied sequence.



Sequence of actions

Numbers set in front indicate successive steps in a procedure.



Battery disposal

This symbol indicates special information about the disposal of batteries and accumulators.

2 For your safety

2.1 Authorised personnel

All operations described in this documentation must be carried out only by trained, qualified personnel authorised by the plant operator. During work on and with the device, the required personal protective equipment must always be worn.

2.2 Appropriate use

The OPTISWITCH 3100 C is a sensor for point level detection. You can find detailed information about the area of application in chapter " *Product description*".

Operational reliability is ensured only if the instrument is properly used according to the specifications in the operating instructions manual as well as possible supplementary instructions.

For safety and warranty reasons, any invasive work on the device beyond that described in the operating instructions manual may be carried out only by personnel authorised by the manufacturer. Arbitrary conversions or modifications are explicitly forbidden.

2.3 Warning about incorrect use

Inappropriate or incorrect use of this product can give rise to application-specific hazards, e.g. vessel overflow through incorrect mounting or adjustment. Damage to property and persons or environmental contamination can result. Also, the protective characteristics of the instrument can be impaired.

2.4 General safety instructions

This is a state-of-the-art instrument complying with all prevailing regulations and directives. The instrument must only be operated in a technically flawless and reliable condition. The operator is responsible for the trouble-free operation of the instrument. When measuring aggressive or corrosive media that can cause a dangerous situation if the instrument malfunctions, the operator has to implement suitable measures to make sure the instrument is functioning properly.

The safety instructions in this operating instructions manual, the national installation standards as well as the valid safety regulations and accident prevention rules must be observed by the user.

For safety and warranty reasons, any invasive work on the device beyond that described in the operating instructions manual may be carried out only by personnel authorised by the manufacturer. Arbitrary conversions or modifications are explicitly forbidden. For safety reasons, only the accessory specified by the manufacturer must be used.

To avoid any danger, the safety approval markings and safety tips on the device must also be observed.

2.5 Safety label on the instrument

The safety approval markings and safety tips on the device must be observed.

2.6 EU conformity

The device fulfils the legal requirements of the applicable EU directives. By affixing the CE marking, we confirm the conformity of the instrument with these directives.

The EU conformity declaration can be found on our homepage.

2.7 SIL conformity

OPTISWITCH 3100 C meets the requirements to the functional safety according to IEC 61508. Further information is available in the Safety Manual "*OPTISWITCH 3XXX*".

2.8 Installation and operation in the USA and Canada

This information is only valid for USA and Canada. Hence the following text is only available in the English language.

Installations in the US shall comply with the relevant requirements of the National Electrical Code (ANSI/NFPA 70).

Installations in Canada shall comply with the relevant requirements of the Canadian Electrical Code.

2.9 Safety instructions for Ex areas

For applications in explosion-proof areas (Ex), only devices with corresponding Ex approval may be used. Observe the Ex-specific safety instructions. These are an integral part of the operating instructions and are enclosed with every device with Ex approval.

3 Product description

3.1 Configuration

Scope of delivery

The scope of delivery encompasses:

- OPTISWITCH 3100 C point level switch
- Documentation
 - This operating instructions manual
 - Ex specific safety instructions (with Ex versions), if necessary further certificates

Constituent parts

The OPTISWITCH 3100 C consists of the components:

- Housing lid
- Housing with electronics
- Process fitting with tuning fork

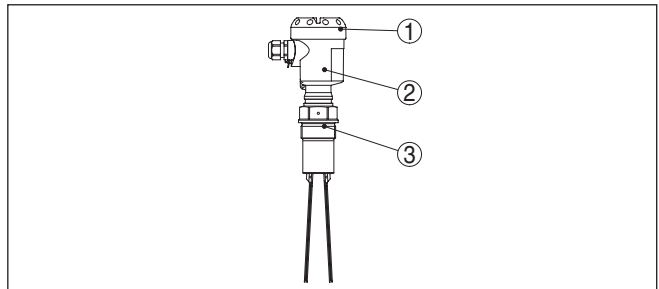

Fig. 1: OPTISWITCH 3100 C with plastic housing

- 1 Housing lid
- 2 Housing with electronics
- 3 Process fitting

Type label

The type label contains the most important data for identification and use of the instrument:

- Article number
- Serial number
- Technical data
- Article numbers, documentation

In addition to the type label outside on the instrument, you find the serial number also inside the instrument.

3.2 Principle of operation

Application area

OPTISWITCH 3100 C is a point level sensor with tuning fork for point level detection.

It is designed for industrial use in all areas of process technology and is preferably used for bulk solids.

Typical applications are overfill and dry run protection. Thanks to its simple and robust measuring system, OPTISWITCH 3100 C is virtually unaffected by the chemical and physical properties of the bulk solid.

It also works when subjected to strong external vibrations or changing products.

Solid detection in water

If OPTISWITCH 3100 C was ordered for solids detection in water, the tuning fork is set to the density of water. In air or when immersed in water (density: 1 g/cm³/0.036 lbs/in), OPTISWITCH 3100 C signals "uncovered". Only when the vibrating element is also covered with solids (e.g. sand, sludge, gravel etc.) will the sensor signal "covered".

Function monitoring

The electronics module of OPTISWITCH 3100 C continuously monitors the following criteria:

- Correct vibrating frequency
- Line break to the piezo drive

If one of these faults is detected, the electronics signals this via a defined current to the signal conditioning instrument. The connection cable to the vibrating element is also monitored.

Functional principle

The tuning fork is piezoelectrically energised and vibrates at its mechanical resonance frequency of approx. 150 Hz. When the tuning fork is submerged in the product, the vibration amplitude changes. This change is detected by the integrated electronics module and converted into a switching command.

Voltage supply

OPTISWITCH 3100 C with NAMUR electronics can be connected to different NAMUR amplifiers depending on your requirements. The specifications for NAMUR amplifiers are available in the "*Technical data*".

The data for power supply are specified in chapter "*Technical data*".

3.3 Adjustment

On the electronics module you will find the following display and adjustment elements:

- Control lamp for indication of the switching status (yellow)
- Potentiometer for adaptation to the product density
- Mode switch to select the switching condition (reverse characteristics)
- Simulation key

3.4 Storage and transport

Packaging

Your instrument was protected by packaging during transport. Its capacity to handle normal loads during transport is assured by a test based on ISO 4180.

The packaging of standard instruments consists of environment-friendly, recyclable carton material. The sensing element is additionally protected with a cardboard cover. For special versions, PE foam or PE foil is also used. Please dispose of the packaging material through specialised recycling companies.

Transport	Transport must be carried out in due consideration of the notes on the transport packaging. Nonobservance of these instructions can cause damage to the device.
Transport inspection	The delivery must be checked for completeness and possible transit damage immediately at receipt. Ascertained transit damage or concealed defects must be appropriately dealt with.
Storage	<p>Up to the time of installation, the packages must be left closed and stored according to the orientation and storage markings on the outside.</p> <p>Unless otherwise indicated, the packages must be stored only under the following conditions:</p> <ul style="list-style-type: none">● Not in the open● Dry and dust free● Not exposed to corrosive media● Protected against solar radiation● Avoiding mechanical shock and vibration
Storage and transport temperature	<ul style="list-style-type: none">● Storage and transport temperature see chapter "<i>Supplement - Technical data - Ambient conditions</i>"● Relative humidity 20 ... 85 %
Lifting and carrying	With instrument weights of more than 18 kg (39.68 lbs) suitable and approved equipment must be used for lifting and carrying.

4 Mounting

4.1 General instructions

Process conditions



Note:

For safety reasons, the instrument must only be operated within the permissible process conditions. You can find detailed information on the process conditions in chapter " *Technical data*" of the operating instructions or on the type label.

Hence make sure before mounting that all parts of the instrument exposed to the process are suitable for the existing process conditions.

These are mainly:

- Active measuring component
- Process fitting
- Process seal

Process conditions in particular are:

- Process pressure
- Process temperature
- Chemical properties of the medium
- Abrasion and mechanical influences

Suitability for the ambient conditions

The instrument is suitable for standard and extended ambient conditions acc. to DIN/EN/IEC/ANSI/ISA/UL/CSA 61010-1. It can be used indoors as well as outdoors.

Switching point

In general, OPTISWITCH 3100 C can be installed in any position. The instrument only has to be mounted in such a way that the vibrating element is at the height of the desired switching point.

Moisture

Use the recommended cables (see chapter " *Connecting to power supply*") and tighten the cable gland.

You can give your instrument additional protection against moisture penetration by leading the connection cable downward in front of the cable gland. Rain and condensation water can thus drain off. This applies mainly to outdoor mounting as well as installation in areas where high humidity is expected (e.g. through cleaning processes) or on cooled or heated vessels.

To maintain the housing protection, make sure that the housing lid is closed during operation and locked, if necessary.

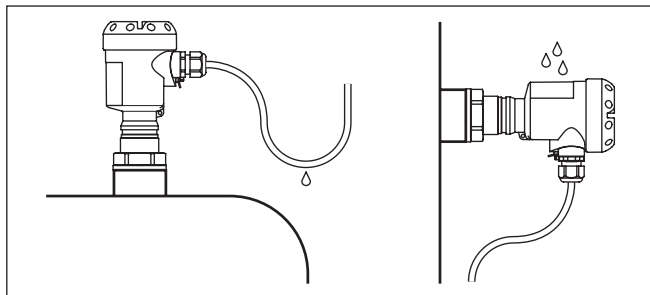

Fig. 2: Measures against moisture ingress

Transport

Do not hold OPTISWITCH 3100 C on the vibrating element. Especially with flange and tube versions, the sensor can be damaged by the weight of the instrument.

Remove the protective cover just before mounting.

Pressure/Vacuum

The process fitting must be sealed if there is gauge or low pressure in the vessel. Before use, check if the sealing material is resistant against the measured product and the process temperature.

The max. permissible pressure is specified in chapter " *Technical data*" or on the type label of the sensor.

Handling

The vibrating level switch is a measuring instrument and must be treated accordingly. Bending the vibrating element will destroy the instrument.



Warning:

The housing must not be used to screw the instrument in! Applying tightening force can damage internal parts of the housing.

Use the hexagon above the thread for screwing in.

Cable entries - NPT thread Cable glands

Metric threads

In the case of instrument housings with metric thread, the cable glands are screwed in at the factory. They are sealed with plastic plugs as transport protection.

You have to remove these plugs before electrical connection.

NPT thread

In the case of instrument housings with self-sealing NPT threads, it is not possible to have the cable entries screwed in at the factory. The free openings for the cable glands are therefore covered with red dust protection caps as transport protection.

Prior to setup you have to replace these protective caps with approved cable glands or close the openings with suitable blind plugs.

4.2 Mounting instructions

Mounting socket

The vibrating element should protrude into the vessel to avoid buildup. For that reason, avoid using mounting bosses for flanges

and screwed fittings. This applies particularly to use with adhesive products.

Filling opening

Mount the instrument in such a way that the tuning fork does not protrude directly into the filling stream.

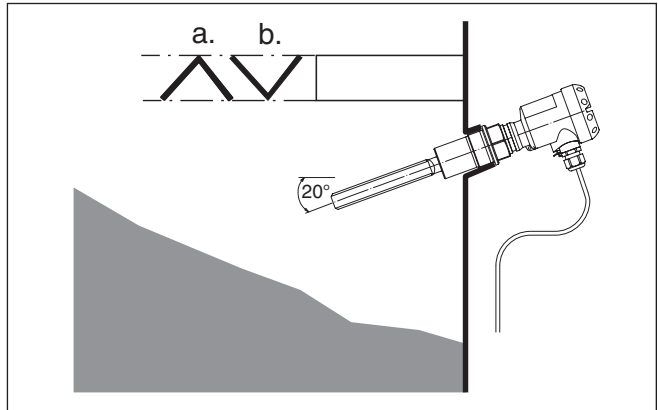

Fig. 3: Horizontal installation

a Protective sheet

b Concave protective sheet for abrasive solids

If such an installation location should be necessary, mount a suitable protective sheet above or in front of the vibrating element, see illustration "a").

In abrasive solids, mounting according to illustration "b" has proven. A spout forms in the concave protective sheet preventing wear of the protective sheet.

Horizontal mounting

To achieve a very precise switching point, you can install OPTISWITCH 3100 C horizontally. However, if the switching point can have a tolerance of a few centimeters, we recommend mounting OPTISWITCH 3100 C approx. 20° inclined to the vessel bottom to avoid buildup.

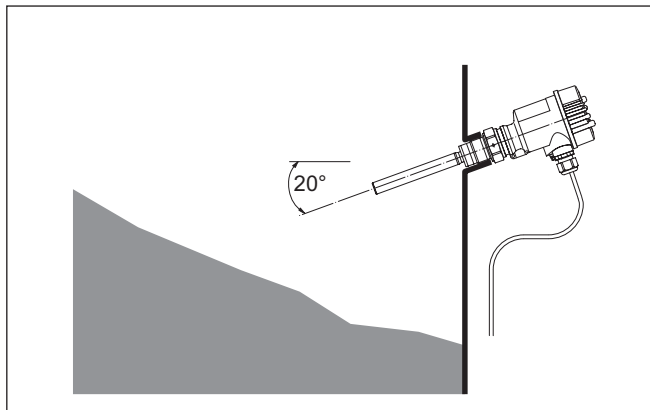

Fig. 4: Horizontal mounting

Inflowing medium

If OPTISWITCH 3100 C is mounted in the filling stream, unwanted false measurement signals can be generated. For this reason, mount OPTISWITCH 3100 C at a position in the vessel where no disturbances, e.g. from filling openings, agitators, etc., can occur.

Product flow

To make sure the tuning fork of OPTISWITCH 3100 C generates as little resistance as possible to product flow, mount the sensor so that the surfaces are parallel to the product movement.

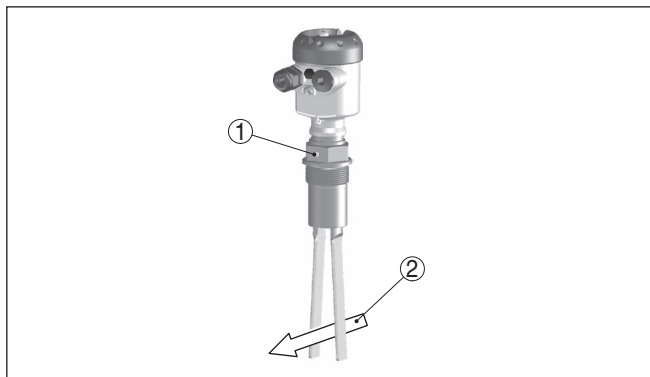

Fig. 5: Flow orientation of the tuning fork

- 1 Marking with screwed version
- 2 Direction of flow

Adhesive products

In case of horizontal mounting in adhesive products, the surfaces of the tuning fork should be vertical in order to reduce buildup on the tuning fork. On the screwed version you will find a marking on the hexagon. With this, you can check the position of the tuning fork when screwing it in. When the hexagon touches the seal, the thread can still

be turned by approx. half a turn. This is sufficient to reach the recommended installation position.

In the case of flange versions, the fork is aligned with the flange holes.

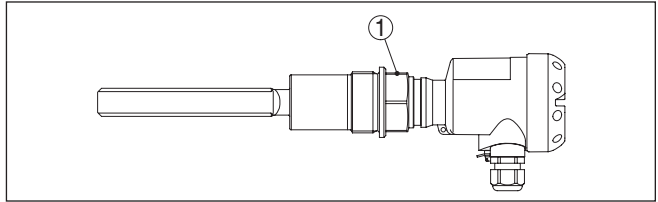

Fig. 6: Horizontal installation - marking

1 Marking on top with screwed version

Baffle protection against falling rocks

In applications such as grit chambers or settling basins for coarse sediments, the vibrating element must be protected against damage with a suitable baffle.

This baffle must be manufactured by you.

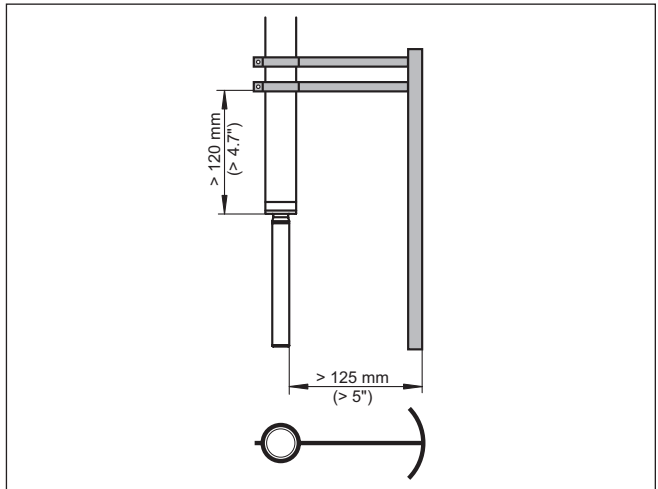

Fig. 7: Baffle for protection against mechanical damage

5 Connecting to power supply

5.1 Preparing the connection

Note safety instructions Always keep in mind the following safety instructions:



Warning:

Connect only in the complete absence of line voltage.

- The electrical connection must only be carried out by trained, qualified personnel authorised by the plant operator.
- Always switch off power supply, before connecting or disconnecting the instrument.

Take note of safety instructions for Ex applications



In hazardous areas you must take note of the respective regulations, conformity and type approval certificates of the sensors and power supply units.

Voltage supply

Connect the voltage supply according to the following diagrams. Take note of the general installation regulations. As a rule, connect OPTISWITCH 3100 C to vessel ground (PA), or in case of plastic vessels, to the next ground potential. On the side of the instrument housing there is a ground terminal between the cable entries. This connection serves to drain off electrostatic charges. In Ex applications, the installation regulations for hazardous areas must be given priority.

The data for power supply are specified in chapter "*Technical data*".

Connection cable

The instrument is connected with standard two-wire cable without screening. If electromagnetic interference is expected which is above the test values of EN 61326 for industrial areas, screened cable should be used.

Make sure that the cable used has the required temperature resistance and fire safety for max. occurring ambient temperature

Use cable with round cross-section. A cable outer diameter of 5 ... 9 mm (0.2 ... 0.35 in) ensures the seal effect of the cable gland. If you are using cable with a different diameter or cross-section, exchange the seal or use a suitable cable gland.



In hazardous areas, use only approved cable connections for OPTISWITCH 3100 C.

Connection cable for Ex applications



Take note of the corresponding installation regulations for Ex applications.

Cover all housing openings conforming to standard according to EN 60079-1.

5.2 Connection procedure



With Ex instruments, the housing cover may only be opened if there is no explosive atmosphere present.

Proceed as follows:

1. Unscrew the housing lid

2. Loosen compression nut of the cable gland and remove blind plug
3. Remove approx. 10 cm (4 in) of the cable mantle, strip approx. 1 cm (0.4 in) of insulation from the ends of the individual wires
4. Insert the cable into the sensor through the cable entry
5. Lift the opening levers of the terminals with a screwdriver (see following illustration)

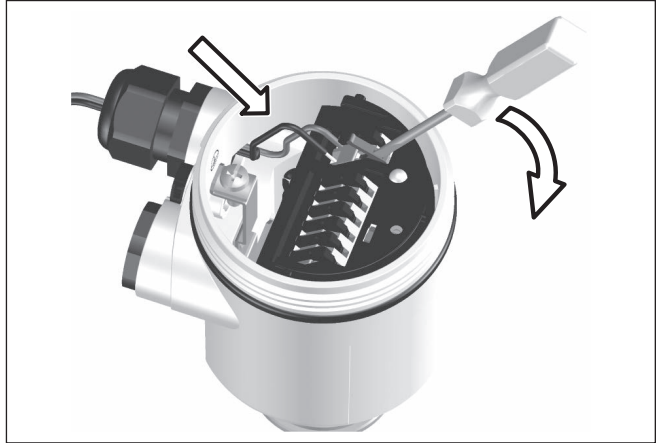

Fig. 8: Connection steps 5 and 6

6. Insert the wire ends into the open terminals according to the wiring plan
 7. Press down the opening levers of the terminals, you will hear the terminal spring closing
 8. Check the hold of the wires in the terminals by lightly pulling on them
 9. Tighten the compression nut of the cable entry gland. The seal ring must completely encircle the cable
 10. If necessary, carry out a fresh adjustment
 11. Screw the housing lid back on
- The electrical connection is finished.

5.3 Wiring plan, single chamber housing



The following illustrations apply to the non-Ex as well as to the Ex-d version.

Housing overview

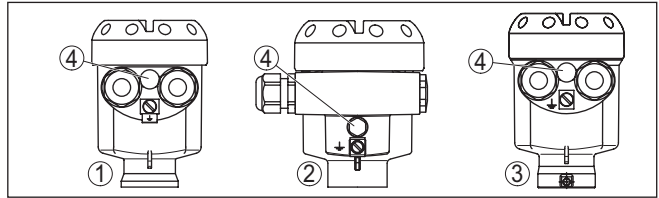

Fig. 9: Material versions, single chamber housing

- 1 Plastic
- 2 Aluminium
- 3 Stainless steel
- 4 Filter element for air pressure compensation

Wiring plan

For connection of the amplifier according to NAMUR (IEC 60947-5-6, EN 50227). You can find further information in the "Technical data".

Further information you will find in the "Technical data", "Ex technical data" are specified in the attached "Safety instructions manual".

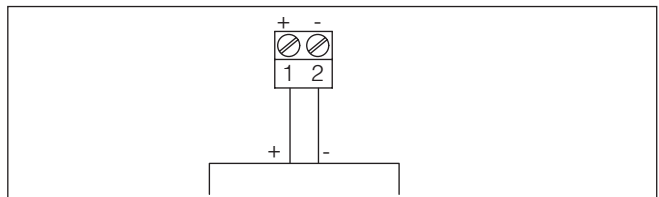

Fig. 10: Wiring plan, single chamber housing

External simulation key

In addition to the test key on the electronics module, you can connect an external key to start the test procedure. Connect the key according to the following wiring plan. In shipping condition, terminals 3 and 4 are bridged.

For additional information see "Recurring function test".

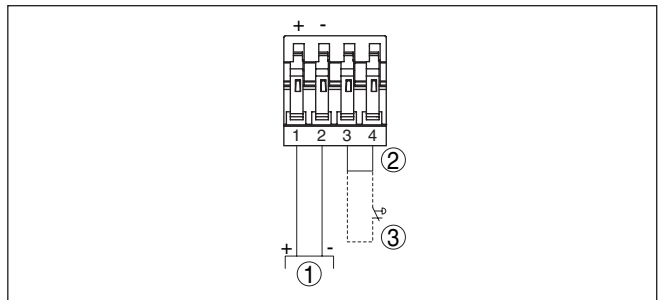

Fig. 11: Wiring plan - External simulation key

- 1 NAMUR amplifier
- 2 Bridge
- 3 External simulation key

6 Setup

6.1 General information

The figures in brackets refer to the following illustrations.

Function/Configuration

On the electronics module you will find the following display and adjustment elements:

- Potentiometer for adjustment of the density range (1)
- DIL switch for mode adjustment - min./max. (2)
- Simulation key (3)
- Signal lamp (6)

Electronics and connection compartment

6.2 Adjustment elements

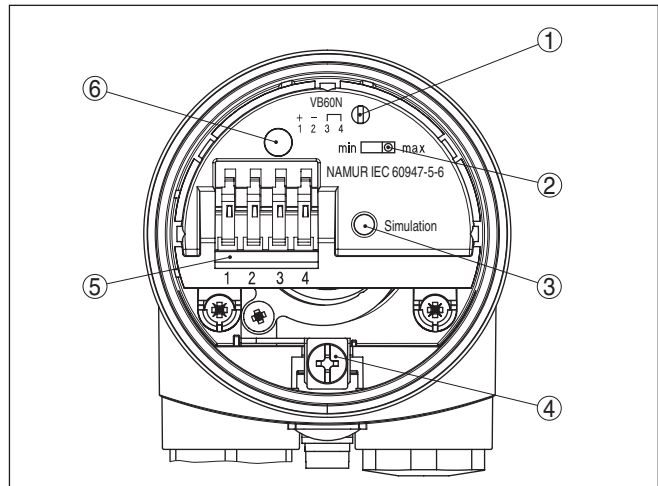

Fig. 12: Electronics and connection compartment - NAMUR output

- 1 Potentiometer for adjustment of the density range
- 2 DIL switch for characteristics reversal
- 3 Simulation key
- 4 Ground terminal
- 5 Connection terminals
- 6 Control lamp

Adjustment of the density range (1)

With the potentiometer you can adapt the switching point to the solid. It is already preset and must only be modified in special cases.

By default, the potentiometer of OPTISWITCH 3100 C is set to the right stop ($> 0.02 \text{ g/cm}^3$ or 0.0008 lbs/in^3). In case of very light-weight solids, turn the potentiometer to the left stop ($> 0.008 \text{ g/cm}^3$ or 0.0003 lbs/in^3). OPTISWITCH 3100 C will thus be more sensitive and can detect light-weight solids more reliably.

For instruments detecting solids in water, these settings are not applicable. The density range is preset and must not be changed.

Characteristics reversal (2)

The characteristics reversal can be carried out with the DIL switch. You can choose between falling characteristic curve (switch position max.) and rising characteristic curve (switch position min.). This allows you to output the desired current.

Modes

- min. - rising characteristic curve (High current when immersed)
- max. - falling characteristics (Low current when immersed)

The NAMUR output can be switched over to falling or rising characteristics (see also "*Function table*").

Simulation key (3)

The simulation key is located in a recess on the upper side of the electronics module. Push the simulation key with a suitable object (screwdriver, pen, etc.).

When the key is pushed, a line break between sensor and processing unit is simulated. The signal lamp on the sensor extinguishes. The measuring system must signal a fault and take on a safe state when the key is pushed.

Keep in mind that downstream connected instruments will be activated during operation. This allows you to check the correct function of the measuring system.

Signal lamp (6)

Control lamp (LED) for indication of the switching condition





- yellow = High current ≥ 2.2 mA
- dark = Low current ≤ 1.0 mA
- yellow (flashing) = Failure ≤ 1.0 mA





6.3 Function table**Level switch OPTISWITCH 3100 C**

The following table provides an overview of the switching conditions depending on the set mode and the level.

**Note:**

The mode setting on the NAMUR amplifier must be selected in such a way that the switching output takes on safe state in case of failure ($I \leq 1$ mA).

	Level	Signal current - Sensor	Control lamp
Falling characteristics max.		≥ 2.2 mA	
Falling characteristics max.		≤ 1 mA	

	Level	Signal current - Sensor	Control lamp
Rising characteristics min.		$\geq 2.2 \text{ mA}$	
Rising characteristics min.		$\leq 1 \text{ mA}$	
Fault	any	$\leq 1 \text{ mA}$	 flashes

6.4 Proof test (SIL)

According to IEC 61508.

The OPTISWITCH 3100 C is qualified for use in measuring chains of level SIL2 according to IEC 61508 (redundant, level SIL3).

SIL

The following instrument combinations meet the requirements according to SIL:

OPTISWITCH 3100 C

- Oscillator WE60N

Proof test

The proof test according to IEC 61508 can be carried out by pushing the simulation key on the electronics module or by briefly (> 2 seconds) interrupting the cable to the sensor. The correct sequence of the switching conditions must be monitored via the switching amplifier as well as the connected systems. The sensor must neither be removed nor response must be triggered by filling the vessel. This applies to OPTISWITCH 3100 C with NAMUR electronics module WE60N.

You can carry out the function test with the output current values also directly via a safety PLC or a process control system.

Simulation key on the electronics module

A function test can be carried out for measurement setups in conjunction with the NAMUR electronics module WE60N. For this purpose, the switching delay must be set to 0.5 s. OPTISWITCH 3100 C has an integrated simulation key. The simulation key is lowered on the electronics module. Push the simulation key for > 2 seconds.

If OPTISWITCH 3100 C is connected to an SPLC, you have to interrupt the connection cable to the sensor for > 2 seconds.

After releasing the simulation key or briefly interrupting the connection cable to the sensor, you can check the complete measuring system on correct function. A switching procedure is simulated during the test.

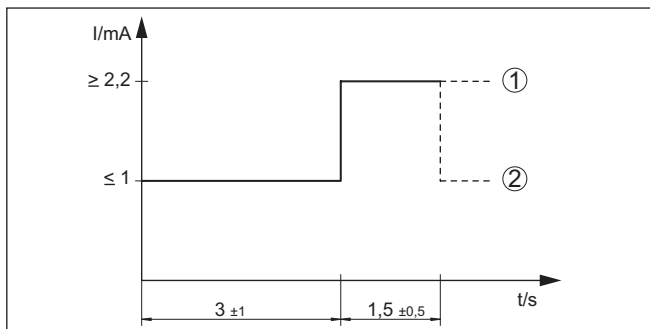

Fig. 13: Flow chart of the function test

- 1 Full signal
- 2 Empty signal

Check if all the switching conditions occur in the correct sequence and the stated time period. If this is not the case, there is a fault in the measuring system. Keep in mind that connected instruments are activated during the function test. This allows you to check the correct function of the measuring system.



Note:

Keep in mind that the starting time t_A of the voltage supply can extend the time up to the first switching.

Test procedure

After releasing the button or after a brief line break.

	Sensor current	Level relay amplifier - overflow protection	Level relay amplifier - dry run protection	Signal lamp amplifier - overflow protection	Signal lamp amplifier - dry run protection	Signal lamp - sensor
1. Low Current (3 s ± 1 s)	≤ 1 mA	energized	currentless			
2. High Current (1.5 s ± 0.5 s)	approx. ≥ 2.2 mA	currentless	energized			
3. Return to the actual operating condition						

You can carry out the function test with the stated current values also directly with a safety PLC or a process control system.

7 Maintenance and fault rectification

7.1 Maintenance

Maintenance

If the device is used properly, no special maintenance is required in normal operation.

Cleaning

The cleaning helps that the type label and markings on the instrument are visible.

Take note of the following:

- Use only cleaning agents which do not corrode the housings, type label and seals
- Use only cleaning methods corresponding to the housing protection rating

7.2 Rectify faults

Reaction when malfunction occurs

The operator of the system is responsible for taking suitable measures to rectify faults.

Causes of malfunction

The device offers maximum reliability. Nevertheless, faults can occur during operation. These may be caused by the following, e.g.:

- Sensor
- Process
- Voltage supply
- Signal processing

Fault rectification

The first measure to take is to check the output signal. In many cases, the causes can be determined this way and the faults quickly rectified.

Checking the switching signal

Error	Cause	Rectification
OPTISWITCH 3100 C signals "covered" without being submerged (overflow protection) OPTISWITCH 3100 C signals "uncovered" when being submerged (dry run protection)	Operating voltage too low	Check operating voltage
	Electronics defective	Press the characteristic reversal switch. If the instrument then changes the mode, the vibrating element may be covered with buildup or mechanically damaged. Should the switching function in the correct mode still be faulty, return the instrument for repair.
		Push the characteristic reversal switch. If the instrument then does not change the mode, the electronics module may be defective. Exchange the electronics module.
	Unfavourable installation location	Mount the instrument at a location in the vessel where no dead zones or air bubbles can form.
	Buildup on the vibrating element	Check the vibrating element and the sensor for buildup and remove the buildup if there is any.
	Wrong characteristic selected	Set the correct characteristics on the characteristics reversal switch (overflow protection, dry run protection). Wiring should be carried out according to the idle current principle.

Error	Cause	Rectification
Signal lamp flashes yellow	Error on the vibrating element	Check if the vibrating element is damaged or extremely corroded.
	Interference on the electronics module	Exchanging the electronics module
	instrument defective	Exchange the instrument or send it in for repair

Reaction after fault rectification

Depending on the reason for the fault and the measures taken, the steps described in chapter "Setup" must be carried out again or must be checked for plausibility and completeness.

7.3 Exchanging the electronics module

In general, all electronics modules of series WE60 can be interchanged. If you want to use an electronics module with a different signal output, you can download the corresponding operating instructions manual from our homepage under Downloads.



With Ex-d instruments, the housing cover may only be opened if there is no explosive atmosphere present.

Proceed as follows:

1. Switch off voltage supply
2. Unscrew the housing lid
3. Lift the opening levers of the terminals with a screwdriver
4. Pull the connection cables out of the terminals
5. Loosen the two screws with a screw driver (Torx size T10 or slot 4)

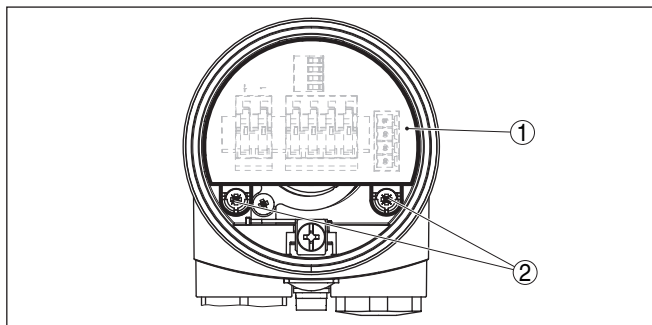

Fig. 14: Loosen the holding screws

- 1 Electronics module
- 2 Screws (2 pcs.)

6. Pull out the old electronics module
7. Compare the new electronics module with the old one. The type label of the electronics module must correspond to that of the old electronics module. This applies particularly to instruments used in hazardous areas.

8. Compare the settings of the two electronics modules. Set the adjustment elements of the new electronics module to the same setting of the old one.

**Information:**

Make sure that the housing is not rotated during the electronics exchange. Otherwise the plug may be in a different position later.

9. Insert the electronics module carefully. Make sure that the plug is in the correct position.
10. Screw in and tighten the two holding screws with a screwdriver (Torx size T10 or Phillips 4)
11. Insert the wire ends into the open terminals according to the wiring plan
12. Press down the opening levers of the terminals, you will hear the terminal spring closing
13. Check the hold of the wires in the terminals by lightly pulling on them
14. Check cable gland on tightness. The seal ring must completely encircle the cable.
15. Screw the housing lid back on

The electronics exchange is now finished.

7.4 How to proceed if a repair is necessary

If it is necessary to repair the instrument, please contact the responsible Krohne agency.

8 Dismount

8.1 Dismounting steps

**Warning:**

Before dismounting, be aware of dangerous process conditions such as e.g. pressure in the vessel, high temperatures, corrosive or toxic products etc.

Take note of chapters "*Mounting*" and "*Connecting to voltage supply*" and carry out the listed steps in reverse order.



With Ex instruments, the housing cover may only be opened if there is no explosive atmosphere present.

8.2 Disposal

The device is made of recyclable materials. For this reason, it should be disposed of by a specialist recycling company. Observe the applicable national regulations.

9 Supplement

9.1 Technical data

General data

Material 316L corresponds to 1.4404 or 1.4435

Materials, wetted parts

– Process fitting - thread	316L
– Process fitting - flange	316L
– Process seal	Klingsil C-4400
– Tuning fork	316L
– Extension tube \varnothing 43 mm (1.7 in)	316L

Materials, non-wetted parts

– Plastic housing	Plastic PBT (Polyester)
– Aluminium die-cast housing	Aluminium die-casting AlSi10Mg, powder-coated (Basis: Polyester)
– Stainless steel housing (precision casting)	316L
– Stainless steel housing (electropolished)	316L
– Seal between housing and housing lid	Silicone
– Light guide in housing cover (plastic)	PMMA (Makrolon)
– Ground terminal	316L
– Cable gland	PA, stainless steel, brass
– Sealing, cable gland	NBR
– Blind plug, cable gland	PA

Process fittings

– Pipe thread, cylindrical (DIN 3852-A)	G1½
– Pipe thread, conical (ASME B1.20.1)	1½ NPT

Instrument weight (depending on process fitting) 0.8 ... 4 kg (0.18 ... 8.82 lbs)

Max. lateral load 600 N (135 lbf)



Fig. 15: Max. lateral load alongside fork side (narrow fork side)

Torque for NPT cable glands and Conduit tubes

- Plastic housing max. 10 Nm (7.376 lbf ft)
- Aluminium/Stainless steel housing max. 50 Nm (36.88 lbf ft)

Output variable

Output	Two-wire NAMUR output
Current consumption	
- Falling characteristics (max.)	≥ 2.2 mA uncovered/≤ 1.0 mA covered
- Rising characteristics (min.)	≤ 1.0 mA uncovered/≥ 2.2 mA covered
- Fault message	≤ 1,0 mA
Necessary processing system	NAMUR processing system according to IEC 60947-5-6 (EN 50227/DIN 19234)
Modes (NAMUR output adjustable to falling or rising characteristics)	
- Min.	rising characteristic curve (High current when immersed)
- Max.	falling characteristics (Low current when immersed)

Ambient conditions

Ambient temperature on the housing	-40 ... +80 °C (-40 ... +176 °F)
Storage and transport temperature	-40 ... +80 °C (-40 ... +176 °F)

Process conditions

Measured variable	Limit level of solids
Process pressure	-1 ... 25 bar/-100 ... 2500 kPa (-14.5 ... 363 psig)
OPTISWITCH 3100 C of 316L	-50 ... +150 °C (-58 ... +302 °F)
Process temperature (thread or flange temperature) with temperature adapter (option)	-50 ... +250 °C (-58 ... +482 °F)

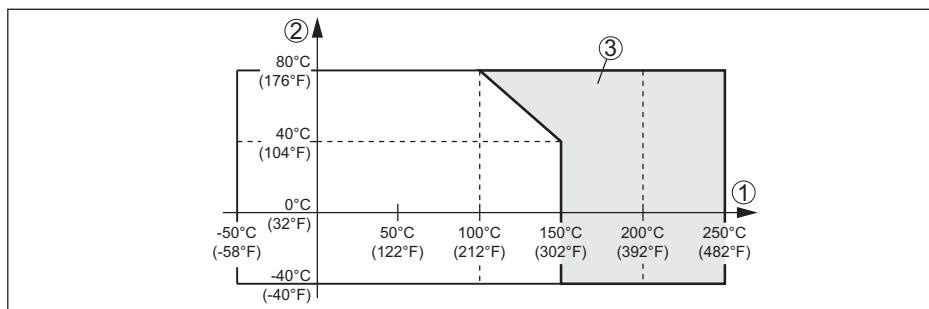

Fig. 16: Ambient temperature - Process temperature

- 1 Process temperature
- 2 Ambient temperature
- 3 Temperature range with temperature adapter

Product density

- Standard sensitivity > 0.02 g/cm³ (0.0007 lbs/in³)

31356-EN-210702

– High sensitivity	> 0.008 g/cm ³ (0.0003 lbs/in ³)
Granular size	max. 10 mm (0.4 in)

Electromechanical data

Options of the cable entry

– Cable entry	M20 x 1,5, ½ NPT
– Kabelverschraubung	M20 x 1,5, ½ NPT
– Blindstopfen	M20 x 1,5, ½ NPT
– Verschlusskappe	½ NPT

Wire cross-section (spring-loaded terminals)

– Massive wire, stranded wire	0.2 ... 2.5 mm ² (AWG 24 ... 14)
– Stranded wire with end sleeve	0.2 ... 1.5 mm ² (AWG 24 ... 16)

Adjustment elements

Mode switch

– Min.	rising characteristic curve (High current when immersed)
– Max.	falling characteristics (Low current when immersed)

Potentiometer for switching point adaptation 0.02 ... 0.1 g/cm³ (0.0007 ... 0.0036 lbs/in³)

Simulation key simulation of a line break between sensor and processing unit

Voltage supply

Operating voltage (characteristics according to standard) for connection to an amplifier according to NAMUR IEC 60947-5-6, approx. 8.2 V

Off-load voltage U₀ approx. 8.2 V

Short-circuit current I₀ approx. 8.2 mA

Electrical protective measures

Protection rating A suitable cable is required for maintaining the protection rating.

Housing material	Protection acc. to IEC 60529	Protection acc. to NEMA
Plastic	IP 66/IP 67	Type 4X
Aluminium	IP 66/IP 68 (0.2 bar)	Type 6P
	IP 68 (1 bar)	Type 6P
Stainless steel (electro-polished)	IP 66/IP 68 (0.2 bar)	Type 6P
	IP 68 (1 bar)	Type 6P
Stainless steel (precision casting)	IP 66/IP 68 (0.2 bar)	Type 6P
	IP 68 (1 bar)	Type 6P

Altitude above sea level up to 5000 m (16404 ft)

Protection class II

Approvals

Depending on the version, instruments with approvals can have different technical data. For these instruments, please note the corresponding approval documents. They are included in the scope of delivery.

9.2 Dimensions

OPTISWITCH 3100 C

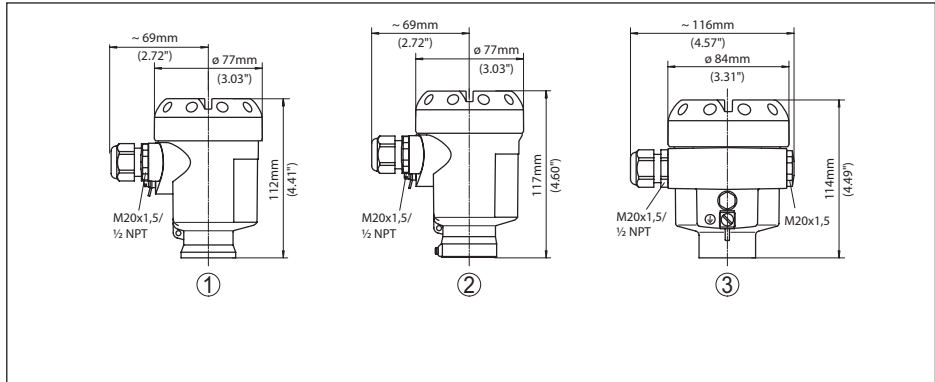

Fig. 17: Housing versions

- 1 Plastic single chamber
- 2 Stainless steel single chamber
- 3 Aluminium - single chamber

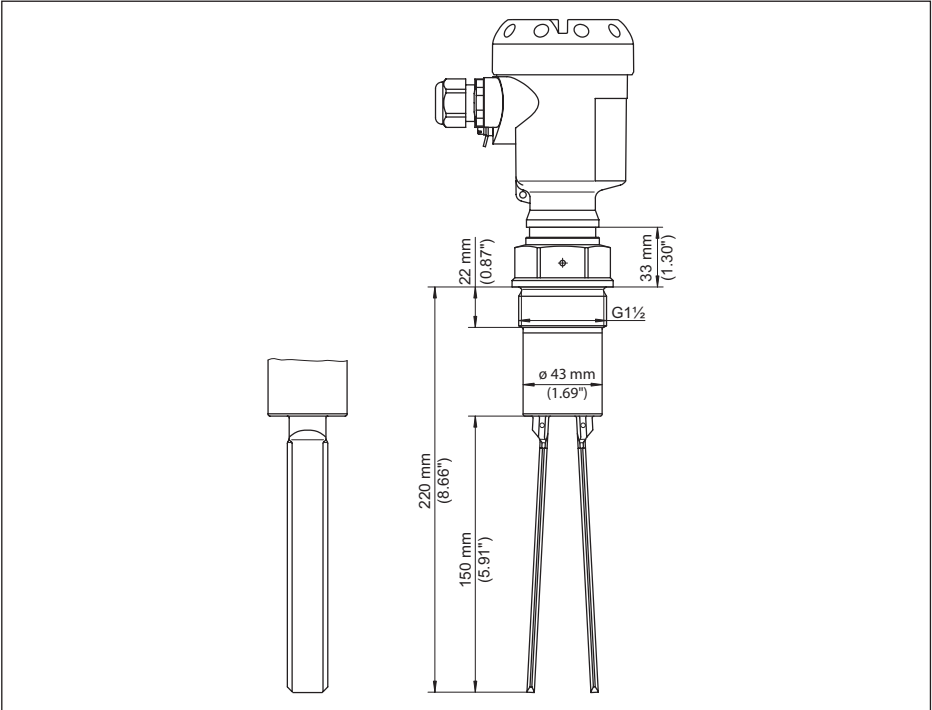

Fig. 18: OPTISWITCH 3100 C, threaded version G1 1/2 (DIN ISO 228/1)

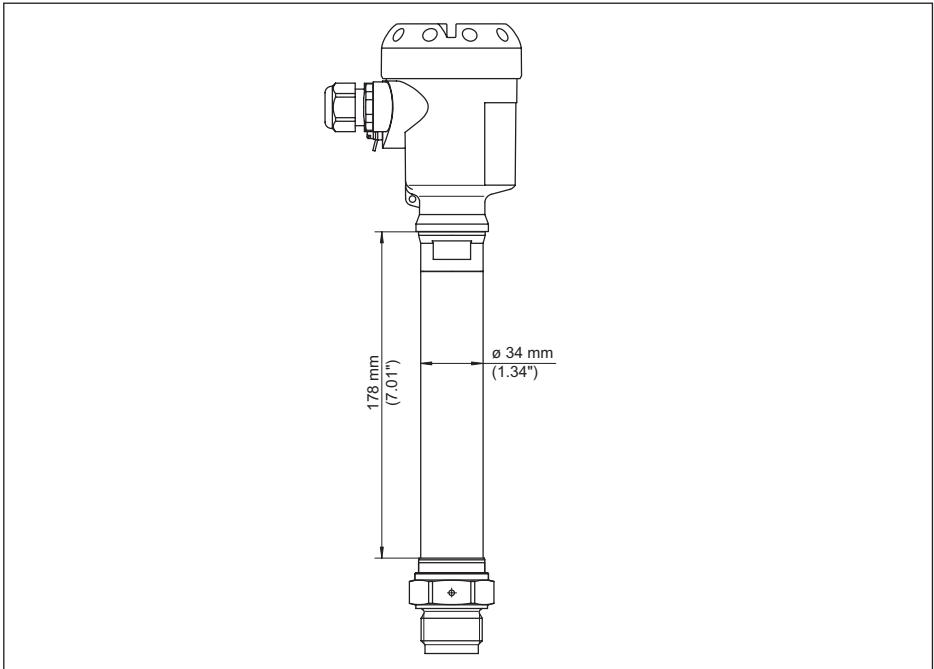
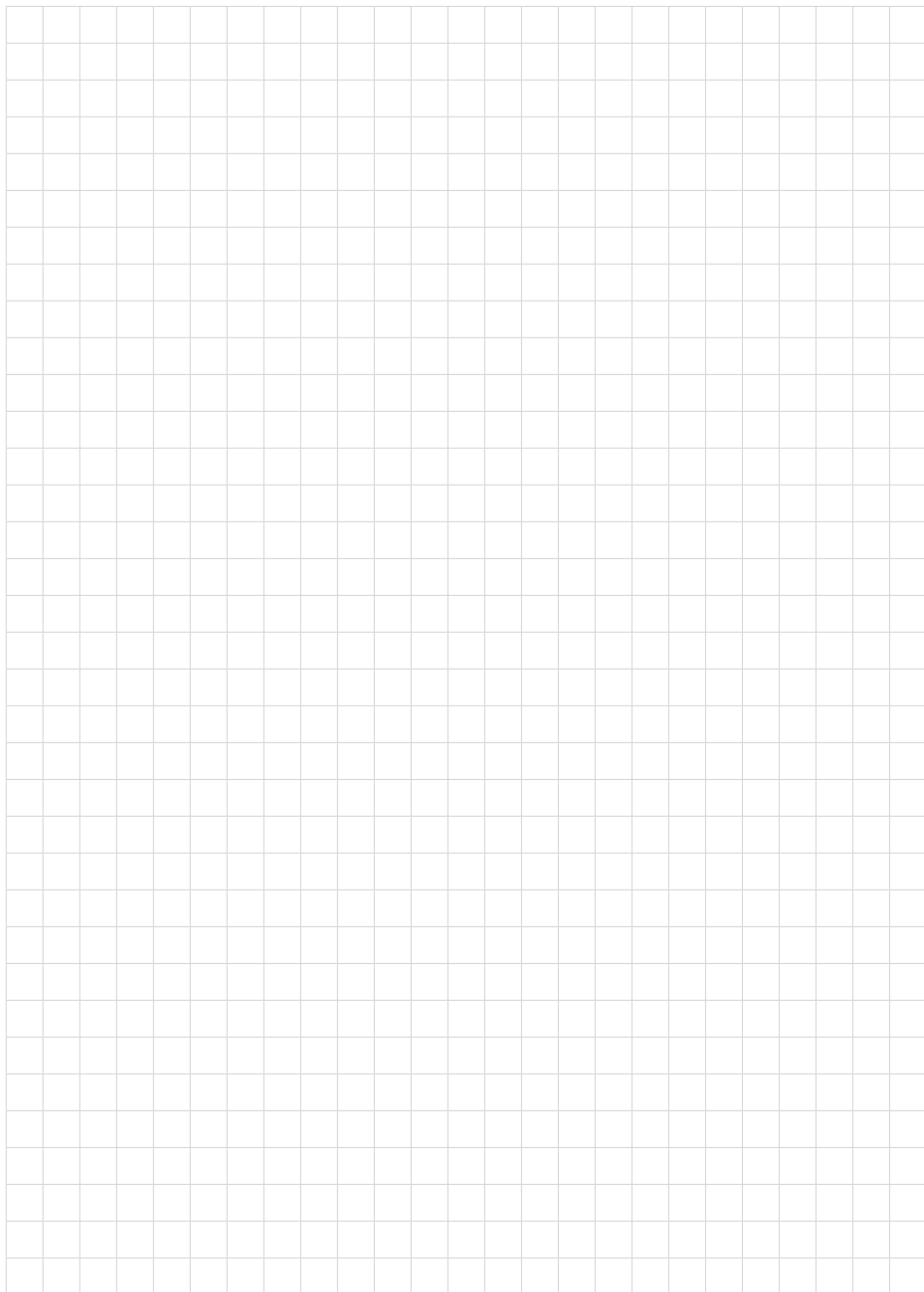

Fig. 19: Temperature adapter

9.3 Trademark

All the brands as well as trade and company names used are property of their lawful proprietor/originator.





A large grid of 25 columns and 30 rows for taking notes. The grid is composed of thin black lines forming a series of small squares. It occupies the central portion of the page, below the header and above the footer.

KROHNE - Products, Solutions and Services

- Process instrumentation for flow, level, temperature, pressure measurement and process analytics
- Flow metering, monitoring, wireless and remote metering solutions
- Engineering, commissioning, calibration, maintenance and training services

Head Office KROHNE Messtechnik GmbH
Ludwig-Krohne-Straße 5
47058 Duisburg (Germany)
Tel.: +49 (0) 203 301 0
Tel.: +49 (0) 203 301 10389
info@krohne.de

The current list of all KROHNE contacts and addresses can be found at:
www.krohne.com

KROHNE