



OPTISWITCH 5200 C, 5250 C

Handbook

Vibrating Level Switch

Two-wire 8/16 mA



KROHNE

Contents

1	About this document	4
1.1	Function	4
1.2	Target group	4
1.3	Symbols used.....	4
2	For your safety	5
2.1	Authorised personnel	5
2.2	Appropriate use.....	5
2.3	Warning about incorrect use.....	5
2.4	General safety instructions	5
2.5	Safety label on the instrument	6
2.6	EU conformity.....	6
2.7	SIL conformity	6
2.8	Installation and operation in the USA and Canada	6
2.9	Safety instructions for Ex areas	6
3	Product description	7
3.1	Configuration.....	7
3.2	Principle of operation.....	8
3.3	Adjustment	8
3.4	Storage and transport.....	9
3.5	Accessories.....	9
4	Mounting	11
4.1	General instructions	11
4.2	Mounting instructions	14
5	Connecting to power supply	17
5.1	Preparing the connection	17
5.2	Connection procedure.....	17
5.3	Wiring plan, single chamber housing.....	18
6	Setup	21
6.1	General information.....	21
6.2	Adjustment elements.....	21
6.3	Function table.....	22
6.4	Proof test (WHG, SIL).....	23
7	Maintenance and fault rectification	29
7.1	Maintenance	29
7.2	Rectify faults.....	29
7.3	Exchanging the electronics	30
7.4	How to proceed if a repair is necessary.....	30
8	Dismount	31
8.1	Dismounting steps.....	31
8.2	Disposal	31
9	Supplement	32
9.1	Technical data	32
9.2	Dimensions	39
9.3	Trademark	42

1 About this document

1.1 Function

This instruction provides all the information you need for mounting, connection and setup as well as important instructions for maintenance, fault rectification, the exchange of parts and the safety of the user. Please read this information before putting the instrument into operation and keep this manual accessible in the immediate vicinity of the device.

1.2 Target group

This operating instructions manual is directed to trained personnel. The contents of this manual must be made available to the qualified personnel and implemented.

1.3 Symbols used



Information, note, tip: This symbol indicates helpful additional information and tips for successful work.



Note: This symbol indicates notes to prevent failures, malfunctions, damage to devices or plants.



Caution: Non-observance of the information marked with this symbol may result in personal injury.



Warning: Non-observance of the information marked with this symbol may result in serious or fatal personal injury.



Danger: Non-observance of the information marked with this symbol results in serious or fatal personal injury.



Ex applications

This symbol indicates special instructions for Ex applications.



List

The dot set in front indicates a list with no implied sequence.



Sequence of actions

Numbers set in front indicate successive steps in a procedure.



Battery disposal

This symbol indicates special information about the disposal of batteries and accumulators.

2 For your safety

2.1 Authorised personnel

All operations described in this documentation must be carried out only by trained, qualified personnel authorised by the plant operator. During work on and with the device, the required personal protective equipment must always be worn.

2.2 Appropriate use

The OPTISWITCH 5200 C, 5250 C is a sensor for point level detection.

You can find detailed information about the area of application in chapter " *Product description*".

Operational reliability is ensured only if the instrument is properly used according to the specifications in the operating instructions manual as well as possible supplementary instructions.

For safety and warranty reasons, any invasive work on the device beyond that described in the operating instructions manual may be carried out only by personnel authorised by the manufacturer. Arbitrary conversions or modifications are explicitly forbidden.

2.3 Warning about incorrect use

Inappropriate or incorrect use of this product can give rise to application-specific hazards, e.g. vessel overflow through incorrect mounting or adjustment. Damage to property and persons or environmental contamination can result. Also, the protective characteristics of the instrument can be impaired.

2.4 General safety instructions

This is a state-of-the-art instrument complying with all prevailing regulations and directives. The instrument must only be operated in a technically flawless and reliable condition. The operator is responsible for the trouble-free operation of the instrument. When measuring aggressive or corrosive media that can cause a dangerous situation if the instrument malfunctions, the operator has to implement suitable measures to make sure the instrument is functioning properly.

The safety instructions in this operating instructions manual, the national installation standards as well as the valid safety regulations and accident prevention rules must be observed by the user.

For safety and warranty reasons, any invasive work on the device beyond that described in the operating instructions manual may be carried out only by personnel authorised by the manufacturer. Arbitrary conversions or modifications are explicitly forbidden. For safety reasons, only the accessory specified by the manufacturer must be used.

To avoid any danger, the safety approval markings and safety tips on the device must also be observed.

2.5 Safety label on the instrument

The safety approval markings and safety tips on the device must be observed.

2.6 EU conformity

The device fulfils the legal requirements of the applicable EU directives. By affixing the CE marking, we confirm the conformity of the instrument with these directives.

The EU conformity declaration can be found on our homepage.

2.7 SIL conformity

OPTISWITCH 5200 C, 5250 C fulfills the requirements on functional safety according to IEC 61508 resp. IEC 61511. You can find further information in the Safety Manual "*OPTISWITCH 5XXX*".

2.8 Installation and operation in the USA and Canada

This information is only valid for USA and Canada. Hence the following text is only available in the English language.

Installations in the US shall comply with the relevant requirements of the National Electrical Code (ANSI/NFPA 70).

Installations in Canada shall comply with the relevant requirements of the Canadian Electrical Code.

2.9 Safety instructions for Ex areas

For applications in explosion-proof areas (Ex), only devices with corresponding Ex approval may be used. Observe the Ex-specific safety instructions. These are an integral part of the operating instructions and are enclosed with every device with Ex approval.

3 Product description

3.1 Configuration

Scope of delivery

The scope of delivery encompasses:

- OPTISWITCH 5200 C, 5250 C point level switch
- Documentation
 - This operating instructions manual
 - Safety Manual "*Functional safety (SIL)*" (optional)
 - Ex-specific "*Safety instructions*" (with Ex versions)
 - If necessary, further certificates

Constituent parts

The OPTISWITCH 5200 C, 5250 C consists of the components:

- Housing lid
- Housing with electronics
- Process fitting with tuning fork

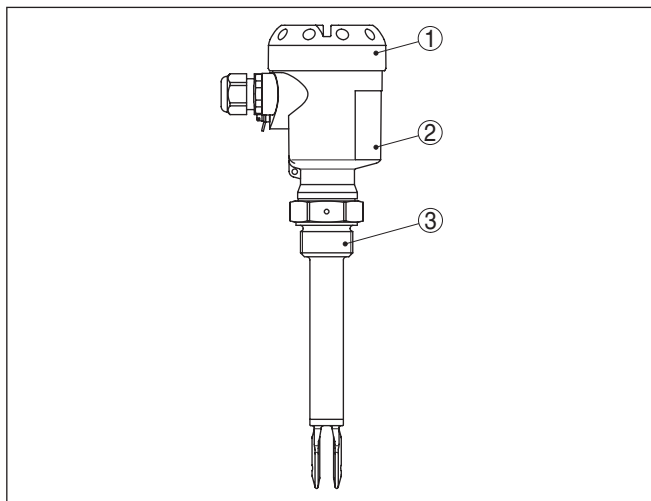

Fig. 1: OPTISWITCH 5200 C, 5250 C

- 1 Housing lid
- 2 Housing with electronics
- 3 Process fitting

Type label

The type label contains the most important data for identification and use of the instrument:

- Article number
- Serial number
- Technical data
- Article numbers, documentation
- SIL identification (with SIL rating ex works)

In addition to the type label outside on the instrument, you find the serial number also inside the instrument.

Application area**3.2 Principle of operation**

OPTISWITCH 5200 C, 5250 C is a point level sensor with tuning fork for point level detection.

It is designed for industrial use in all areas of process technology and can be used in liquids.

Typical applications are overflow and dry run protection. The small tuning fork allows use in all kinds of tanks and vessels. Thanks to its simple and rugged measuring system, OPTISWITCH 5200 C, 5250 C is virtually unaffected by the chemical and physical properties of the liquid.

It functions even under difficult conditions such as turbulence, air bubbles, foam generation, buildup, strong external vibration or changing products.

Function monitoring

The electronics module of OPTISWITCH 5200 C, 5250 C continuously monitors the following criteria via frequency evaluation:

- Strong corrosion or damage on the tuning fork
- Loss of vibration
- Line break to the piezo drive

If one of these faults is detected, the electronics signals it via a defined current to the controller. The connection cable to the sensor is also monitored for line break and short-circuit.

Functional principle

The tuning fork is piezoelectrically energised and vibrates at its mechanical resonance frequency of approx. 1200 Hz. The piezos are fixed mechanically and are hence not subject to temperature shock limitations. The frequency changes when the tuning fork is covered by the medium. This change is detected by the integrated electronics module, transferred as a current value to the processing system and converted there into a switching command.

Voltage supply

Depending on your requirements, OPTISWITCH 5200 C, 5250 C with two-wire electronics can be connected to different controllers. Compatible controllers are listed in chapter " *Technical data*".

The data for power supply are specified in chapter " *Technical data*".

3.3 Adjustment

The switching condition of OPTISWITCH 5200 C, 5250 C with plastic housing can be checked when the housing is closed (signal lamp). With the basic setting, products with a density $\geq 0.7 \text{ g/cm}^3$ (0.025 lbs/in³) can be detected. The instrument can be adapted if products with lower density are to be measured.

On the electronics module you will find the following display and adjustment elements:

- Signal lamp for indication of the switching condition (green/red)
- DIL switch for adaptation to the product density

3.4 Storage and transport

Packaging

Your instrument was protected by packaging during transport. Its capacity to handle normal loads during transport is assured by a test based on ISO 4180.

The packaging of standard instruments consists of environment-friendly, recyclable carton material. The sensing element is additionally protected with a cardboard cover. For special versions, PE foam or PE foil is also used. Please dispose of the packaging material through specialised recycling companies.

Transport

Transport must be carried out in due consideration of the notes on the transport packaging. Nonobservance of these instructions can cause damage to the device.

Transport inspection

The delivery must be checked for completeness and possible transit damage immediately at receipt. Ascertained transit damage or concealed defects must be appropriately dealt with.

Storage

Up to the time of installation, the packages must be left closed and stored according to the orientation and storage markings on the outside.

Unless otherwise indicated, the packages must be stored only under the following conditions:

- Not in the open
- Dry and dust free
- Not exposed to corrosive media
- Protected against solar radiation
- Avoiding mechanical shock and vibration
- Storage and transport temperature see chapter "*Supplement - Technical data - Ambient conditions*"
- Relative humidity 20 ... 85 %

Storage and transport temperature

Lifting and carrying

With instrument weights of more than 18 kg (39.68 lbs) suitable and approved equipment must be used for lifting and carrying.

3.5 Accessories

Flanges

Screwed flanges are available in different versions according to the following standards: DIN 2501, EN 1092-1, BS 10, ASME B 16.5, JIS B 2210-1984, GOST 12821-80.

Electronics module

The electronics module SW E60 is a replacement part for level switches OPTISWITCH 5200 C, 5250 C.

You can find information in the operating instructions manual of the electronics module.

Plug connector

For connecting the sensors with a separator to voltage supply or signal processing, the sensors are also available with plug connectors.

The following plug connectors are available:

- M12 x 1

- ISO 4400
- Harting HAN 7D
- Harting HAN 8D
- Amphenol-Tuchel

4 Mounting

4.1 General instructions

Process conditions



Note:

For safety reasons, the instrument must only be operated within the permissible process conditions. You can find detailed information on the process conditions in chapter " *Technical data*" of the operating instructions or on the type label.

Hence make sure before mounting that all parts of the instrument exposed to the process are suitable for the existing process conditions.

These are mainly:

- Active measuring component
- Process fitting
- Process seal

Process conditions in particular are:

- Process pressure
- Process temperature
- Chemical properties of the medium
- Abrasion and mechanical influences

Suitability for the ambient conditions

The instrument is suitable for standard and extended ambient conditions acc. to DIN/EN/IEC/ANSI/ISA/UL/CSA 61010-1. It can be used indoors as well as outdoors.

Switching point

In general, OPTISWITCH 5200 C, 5250 C can be installed in any position. The instrument only has to be mounted in such a way that the tuning fork is at the height of the desired switching point.

The tuning fork has lateral markings (notches) that indicate the switching point with vertical mounting. The switching point applies to water in conjunction with the basic setting of the density switch $\geq 0.7 \text{ g/cm}^3$ (0.025 lbs/in^3). When mounting OPTISWITCH 5200 C, 5250 C, make sure that this marking is at the height of the requested switching point. Keep in mind that the switching point of the instrument will shift if the medium has a density other than water - water is 1 g/cm^3 (0.036 lbs/in^3). For products $\leq 0.7 \text{ g/cm}^3$ (0.025 lbs/in^3) and $\geq 0.5 \text{ g/cm}^3$ (0.018 lbs/in^3) the density switch must be set to $\geq 0.5 \text{ g/cm}^3$.

Keep in mind that foams with a density $\geq 0.45 \text{ g/cm}^3$ (0.016 lbs/in^3) are detected by the sensor. This can lead to erroneous switchings, particularly when the sensor is used for dry run protection.

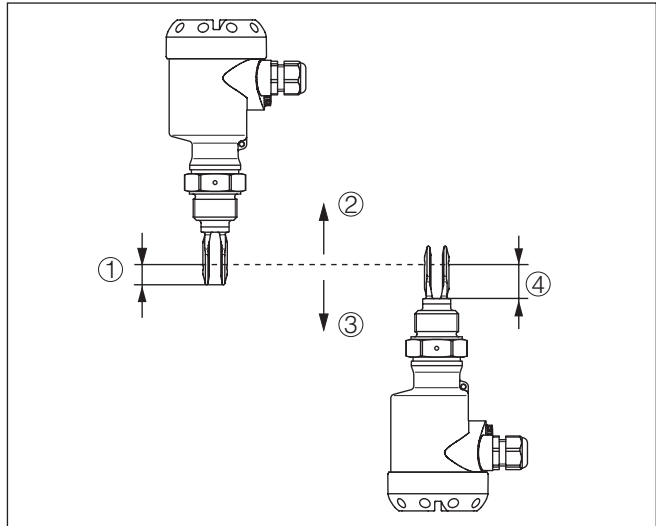

Fig. 2: Vertical mounting

- 1 Switching point approx. 13 mm (0.51 in)
- 2 Switching point with lower density
- 3 Switching point with higher density
- 4 Switching point approx. 27 mm (1.06 in)

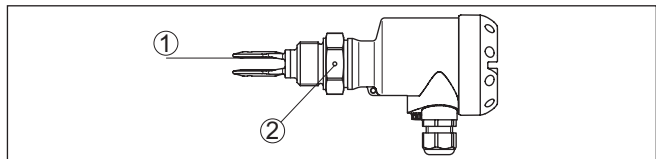

Fig. 3: Horizontal mounting

- 1 Switching point
- 2 Marking with screwed version, facing up

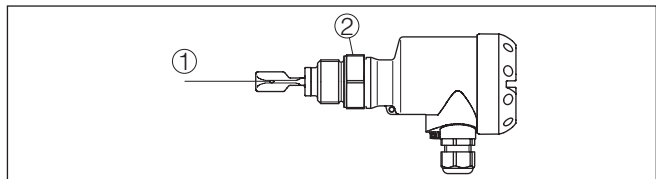

Fig. 4: Horizontal installation (recommended mounting position, particularly for adhesive products)

- 1 Switching point
- 2 Marking with screwed version, facing up

In the case of flange versions, the fork is aligned as follows.

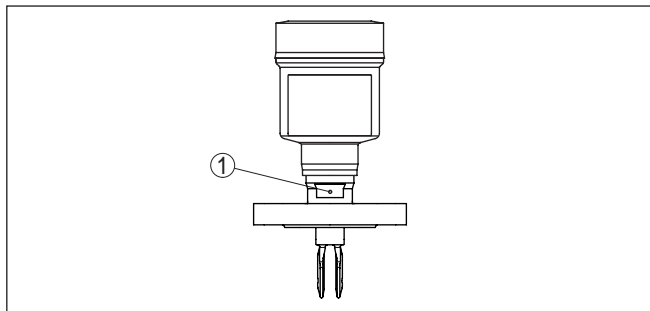

Fig. 5: Fork position with flange versions

1 Marking with flange version, facing up

Moisture

Use the recommended cables (see chapter "Connecting to power supply") and tighten the cable gland.

You can give your instrument additional protection against moisture penetration by leading the connection cable downward in front of the cable gland. Rain and condensation water can thus drain off. This applies mainly to outdoor mounting as well as installation in areas where high humidity is expected (e.g. through cleaning processes) or on cooled or heated vessels.

To maintain the housing protection, make sure that the housing lid is closed during operation and locked, if necessary.

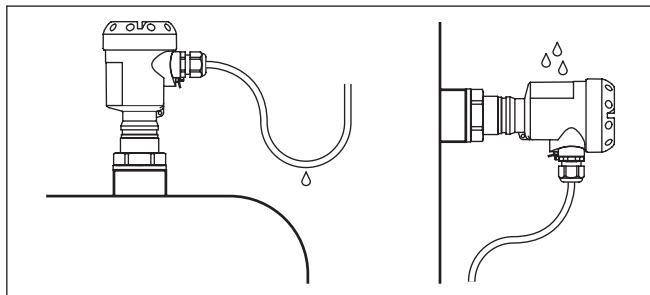

Fig. 6: Measures against moisture ingress

Transport



Caution:

Do not hold OPTISWITCH 5200 C, 5250 C on the tuning fork. Particularly with flange or tube versions, the tuning fork can be damaged just by the weight of the instrument. Transport coated instruments very carefully and avoid touching the tuning fork.

Remove the packaging or the protective cover just before mounting.

Pressure/Vacuum

The process fitting must be sealed if there is gauge or low pressure in the vessel. Before use, check if the sealing material is resistant against the measured product and the process temperature.

The max. permissible pressure is specified in chapter " *Technical data*" or on the type label of the sensor.

Handling

The vibrating level switch is a measuring instrument and must be treated accordingly. Bending the vibrating element will destroy the instrument.



Warning:

The housing must not be used to screw the instrument in! Applying tightening force can damage internal parts of the housing.

Use the hexagon above the thread for screwing in.

Cable entries - NPT thread Cable glands

Metric threads

In the case of instrument housings with metric thread, the cable glands are screwed in at the factory. They are sealed with plastic plugs as transport protection.

You have to remove these plugs before electrical connection.

NPT thread

In the case of instrument housings with self-sealing NPT threads, it is not possible to have the cable entries screwed in at the factory. The free openings for the cable glands are therefore covered with red dust protection caps as transport protection.

Prior to setup you have to replace these protective caps with approved cable glands or close the openings with suitable blind plugs.

4.2 Mounting instructions

Welded socket

OPTISWITCH 5200 C, 5250 C has a defined thread starting point. This means that every OPTISWITCH 5200 C, 5250 C is in the same fork position after being screwed in. Remove therefore the supplied seal from the thread of OPTISWITCH 5200 C, 5250 C. This seal is not required when using a welded socket with O-ring in front.

Keep in mind that this welded socket is not suitable for coated instrument versions.

Screw OPTISWITCH 5200 C, 5250 C completely into the welded socket. The later position can be determined already before welding. Mark the appropriate position of the welded socket. Before welding, unscrew OPTISWITCH 5200 C, 5250 C and remove the rubber ring from the welded socket. The welded socket has a marking (notch). Weld the socket with the notch facing upward, or in case of pipelines (DN 32 up to DN 50), aligned with the direction of flow.

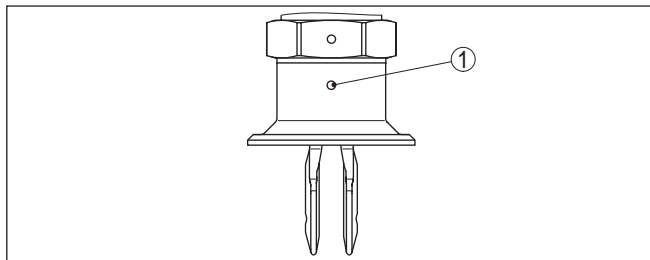

Fig. 7: Marking on the welded socket

1 Marking

Adhesive products

In case of horizontal mounting in adhesive and viscous products, the surfaces of the tuning fork should be vertical in order to reduce buildup on the tuning fork. On the screwed version you will find a marking on the hexagon. With this you can check the position of the tuning fork when screwing it in. When the hexagon touches the seal, the thread can still be turned by approx. half a turn. This is sufficient to reach the recommended installation position.

In the case of flange versions, the fork is aligned with the flange holes. When used in adhesive and viscous products, the tuning fork should protrude into the vessel to avoid buildup. For that reason, sockets for flanges and mounting bosses should be avoided when mounting horizontally.

Inflowing medium

If OPTISWITCH 5200 C, 5250 C is mounted in the filling stream, unwanted false measurement signals can be generated. For this reason, mount OPTISWITCH 5200 C, 5250 C at a position in the vessel where no disturbances, e.g. from filling openings, agitators, etc., can occur. This applies particularly to instrument types with long extension tube.

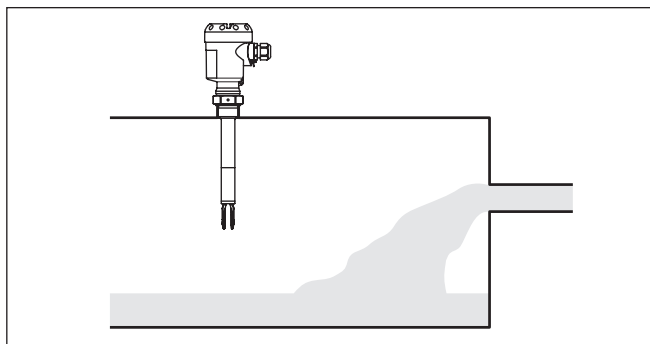

Fig. 8: Inflowing medium

Product flow

To make sure the tuning fork of OPTISWITCH 5200 C, 5250 C generates as little resistance as possible to product flow, mount the sensor so that the surfaces are parallel to the product movement.

Agitators

Due to the effects of agitators, equipment vibration or similar, the level switch can be subjected to strong lateral forces. For this reason, do not use an overly long extension tube for OPTISWITCH 5200 C, 5250 C, but check if you can mount a level switch on the side of the vessel in horizontal position.

Extreme vibration caused by the process or the equipment, e.g. agitators or turbulence in the vessel, can cause the extension tube of OPTISWITCH 5200 C, 5250 C to vibrate in resonance. This leads to increased stress on the upper weld joint. Should a longer tube version be necessary, you can provide a suitable support directly above the tuning fork to secure the extension tube.



This measure applies mainly to applications in Ex areas category 1G or WHG. Make sure that the tube is not subject to bending stress due to this measure.

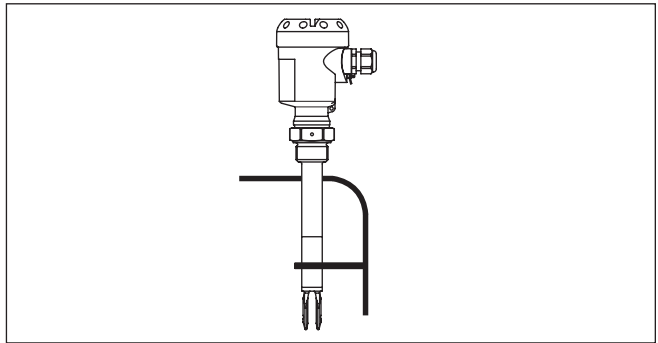

Fig. 9: Lateral support of OPTISWITCH 5200 C, 5250 C

Enamel coating

Instruments with enamel coating should be treated very carefully and shocks should be avoided. Unpack OPTISWITCH 5200 C, 5250 C directly before installation. Insert OPTISWITCH 5200 C, 5250 C carefully into the vessel opening and avoid touching any sharp vessel parts.

Gas-tight leadthrough

The second seal of the gas-tight leadthrough (option) prevents an uncontrolled leakage of the medium. The service life of the gas-tight leadthrough depends on the chemical resistance of the materials. See "Technical data".



Caution:

If it is determined (e.g. via an error message from OPTISWITCH 5200 C, 5250 C) that medium has already penetrated into the vibrating element, the instrument must be exchanged immediately.

5 Connecting to power supply

5.1 Preparing the connection

Note safety instructions Always keep in mind the following safety instructions:



Warning:

Connect only in the complete absence of line voltage.

- The electrical connection must only be carried out by trained, qualified personnel authorised by the plant operator.
- Always switch off power supply, before connecting or disconnecting the instrument.

Take note of safety instructions for Ex applications



In hazardous areas you must take note of the respective regulations, conformity and type approval certificates of the sensors and power supply units.

Voltage supply

Connect the voltage supply according to the following diagrams. Take note of the general installation regulations. As a rule, connect OPTISWITCH 5200 C, 5250 C to vessel ground (PA), or in case of plastic vessels, to the next ground potential. On the side of the instrument housing there is a ground terminal between the cable entries. This connection serves to drain off electrostatic charges. In Ex applications, the installation regulations for hazardous areas must be given priority.

The data for power supply are specified in chapter "*Technical data*".

Connection cable

The instrument is connected with standard two-wire cable without screening. If electromagnetic interference is expected which is above the test values of EN 61326 for industrial areas, screened cable should be used.

Make sure that the cable used has the required temperature resistance and fire safety for max. occurring ambient temperature

Use cable with round cross-section. A cable outer diameter of 5 ... 9 mm (0.2 ... 0.35 in) ensures the seal effect of the cable gland. If you are using cable with a different diameter or cross-section, exchange the seal or use a suitable cable gland.



In hazardous areas, use only approved cable connections for OPTISWITCH 5200 C, 5250 C.

Connection cable for Ex applications



Take note of the corresponding installation regulations for Ex applications.

Cover all housing openings conforming to standard according to EN 60079-1.

5.2 Connection procedure



With Ex instruments, the housing cover may only be opened if there is no explosive atmosphere present.

Proceed as follows:

1. Unscrew the housing lid

2. Loosen compression nut of the cable gland and remove blind plug
 3. Remove approx. 10 cm (4 in) of the cable mantle, strip approx. 1 cm (0.4 in) of insulation from the ends of the individual wires
 4. Insert the cable into the sensor through the cable entry
 5. Open the terminals with a screwdriver
 6. Insert the wire ends into the open terminals according to the wiring plan
 7. Tighten the terminals with a screwdriver
 8. Check the hold of the wires in the terminals by lightly pulling on them
 9. Tighten the compression nut of the cable entry gland. The seal ring must completely encircle the cable
 10. Screw the housing lid back on
- The electrical connection is finished.

5.3 Wiring plan, single chamber housing



The following illustrations apply to the non-Ex as well as to the Ex-d version.

Housing overview

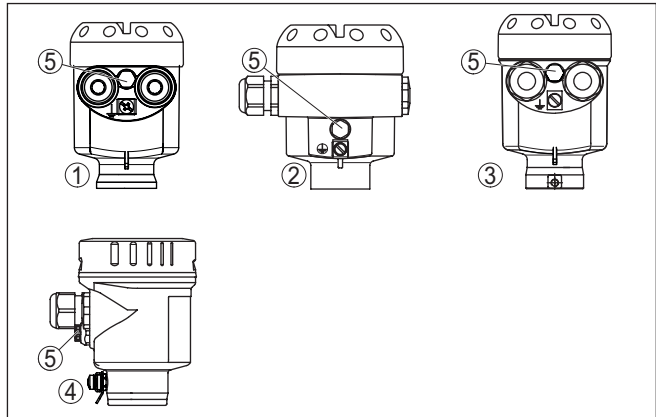

Fig. 10: Material versions, single chamber housing

- 1 Plastic (not with Ex d)
- 2 Aluminium
- 3 Stainless steel, precision casting
- 4 Stainless steel, electropolished (not with Ex d)
- 5 Filter element for pressure compensation (not with Ex d)

Electronics and connection compartment

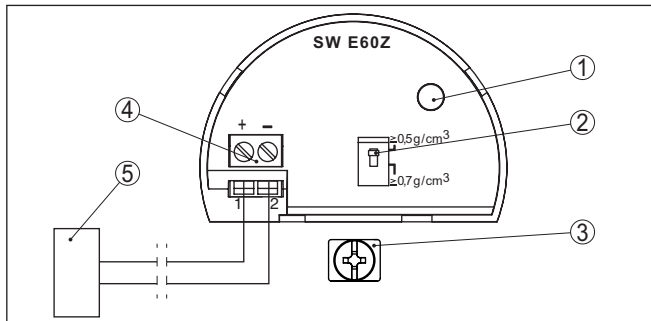

Fig. 11: Electronics and connection compartment

- 1 Control lamp
- 2 DIL switch for sensitivity adjustment
- 3 Ground terminal
- 4 Connection terminals
- 5 Processing system or PLC

Wiring plan

We recommend connecting OPTISWITCH 5200 C, 5250 C in such a way that the switching circuit is open when there is a level signal, line break or failure (safe state).

For connection to a VEGATOR controller dto. Ex, WHG. The sensor is powered by the connected VEGATOR controller. Further information is available in chapter "Technical data", "Ex-technical data" are available in the supplied "Safety information manual".

The wiring example is applicable for all suitable controllers.

The control lamp on OPTISWITCH 5200 C, 5250 C lights in general

- red - with covered tuning fork
- green - with uncovered tuning fork

Take note of the operating instructions manual of the controller. Suitable controllers are listed in chapter "Technical data".

If OPTISWITCH 5200 C, 5250 C is used in Ex areas as part of an overfill protection system according to WHG (Water Resources Act), take note of the regulations in the safety instructions and conformity certificates. If the instrument with electronics module SWE60Z EX, SWE60Z EX E1 is to be operated directly on the analogue input of a PLC, a suitable safety barrier should be connected.

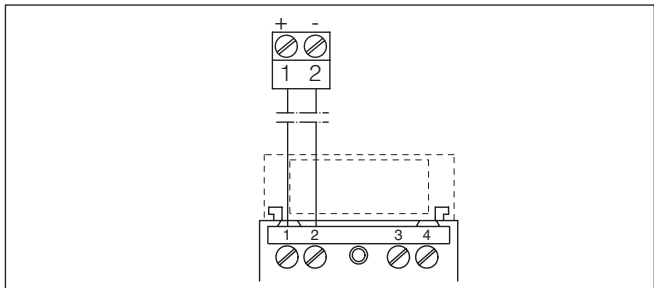

Fig. 12: Wiring plan, single chamber housing

6 Setup

6.1 General information

The figures in brackets refer to the following illustrations.

Function/Configuration

With plastic housings, the switching condition of the electronics can be checked when the housing cover is closed (control lamp). With the basic setting, products with a density $\geq 0.7 \text{ g/cm}^3$ (0.025 lbs/in³) can be detected. For products with lower density, the switch must be set to $\geq 0.5 \text{ g/cm}^3$ (0.018 lbs/in³).

On the electronics module you will find the following display and adjustment elements:

- Control lamp for indication of the switching condition (1)
- DIL switch for adjustment of the density range (2)

Mode adjustment (A/B)

On the controller via the controller

The switching condition can be changed with the A/B switch. You can set the required mode according to the "Function table" (A - max. detection or overflow protection, B - min. detection or dry run protection). The switching delay can also be modified on the controller.



Note:

Always immerse the tuning fork of OPTISWITCH 5200 C, 5250 C in a liquid to test its function. Do not test the function of OPTISWITCH 5200 C, 5250 C with your hand. This can damage the sensor.

6.2 Adjustment elements

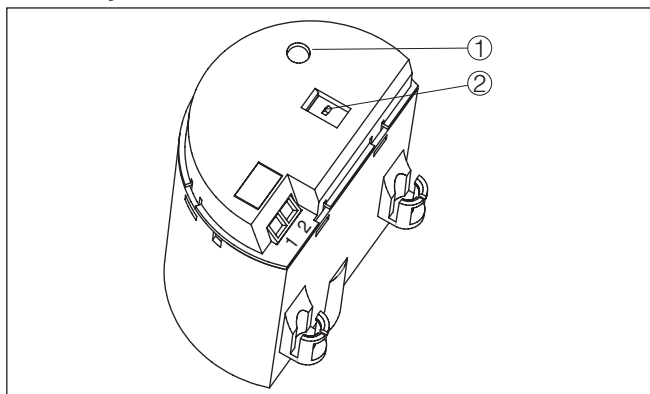

Fig. 13: Oscillator SWE60Z - two-wire output

- 1 Control lamp (LED)
- 2 DIL switch for adjustment of the density range

Signal lamp (1)

Control lamp (LED) for indication of the switching condition

- green = tuning fork uncovered

- red = tuning fork covered
- off = failure

Adjustment of the density range (2)

With this DIL switch (2) you can set the switching point to liquids having a density between 0.5 and 0.7 g/cm³ (0.018 - 0.025 lbs/in³). With the basic setting, liquids with a density of ≥ 0.7 g/cm³ (0.025 lbs/in³) can be detected. In liquids with lower density, you must set the switch to ≥ 0.5 g/cm³ (0.018 lbs/in³). The specifications for the position of the switching point relate to water - density value 1 g/cm³ (0.036 lbs/in³). In products with a different density, the switching point will shift in the direction of the housing or tuning fork end depending on the density and type of installation.













Note:

Keep in mind that foams with a density ≥ 0.45 g/cm³ (0.016 lbs/in³) are detected by the sensor. This can lead to erroneous switchings, particularly when the sensor is used for dry run protection.

6.3 Function table

The following table provides an overview of the switching conditions depending on the set mode and the level.

Mode on the controller	Level	Sensor		Controller	
		Signal current - Sensor	Signal lamp - sensor	Analogue - input control	Signal lamp - controller
Mode A Overflow protection		approx. 8 mA	 Green	> 3.8 mA < 11.5 mA	
Mode A Overflow protection		approx. 16 mA	 Red	> 12.5 mA < 21 mA	○
Mode B Dry run protection		approx. 16 mA	 Red	> 12.5 mA < 21 mA	
Mode B Dry run protection		approx. 8 mA	 Green	> 3.8 mA < 11.5 mA	○

		Sensor		Controller	
Mode on the controller	Level	Signal current - Sensor	Signal lamp - sensor	Analogue - input control	Signal lamp - controller
Fault message (mode A/B)	any	approx. 1.8 mA	○ Off	≤ 3.6 mA ≥ 21 mA	○

6.4 Proof test (WHG, SIL)

The OPTISWITCH 5200 C, 5250 C is qualified for use in measuring chains of level SIL2 according to IEC 61508 (redundant, level SIL3) and is approved according to WHG.

WRA

The implementation of the proof test according to WHG is stipulated in the general type approval, item 8.

Take note of these higher-ranking approvals if OPTISWITCH 5200 C, 5250 C Ex is used as part of an overfill protection system according to WHG.

The following instrument combinations meet the requirements according to WHG:

OPTISWITCH 5200 C, 5250 C Ex with

- Oscillator SW E60Z EX
- Controller SU 501 (Ex) or SPLC (safety-oriented PLC)

SIL

The measuring system can be used for level detection of liquids and meets the special requirements of safety technology.

This is possible up to SIL2 in a single channel architecture (1oo1D), and up to SIL3 in a multiple channel, redundant architecture.

The following instrument combinations meet the requirements according to SIL:

OPTISWITCH 5200 C, 5250 C Ex with

- Oscillator SW E60Z EX
- Controller SU 501 (Ex) or SPLC (safety-oriented PLC)

Implementation - Function test

The following options are available for carrying out the proof test:

1 Filling the vessel up to the switching point

If this does not cause any problems, you can fill the vessel up to the switching point and monitor the correct sensor reaction.

2 Dismounting of the sensor and immersion in the original medium

You can dismantle the sensor for test purposes and check its proper functioning by immersing it in the original product.

3 Short interruption of the supply line to the sensor

The recurring proof test according to IEC 61508 can be carried out through a short interruption (> 2 seconds) of the supply line to the sensor. This starts a test sequence.

The correctness of the subsequent switching conditions on the indications of the SPLC must be monitored. The sensor must neither be dismantled nor triggered by filling the vessel.

- Short interruption of the power supply
- Test key on SU 501 Ex - by monitoring the switching sequence of the test process

You can carry out the function test with the output current values also directly via a safety PLC or a process control system.

SIL

To find out possible undetected, dangerous failures, a proof test must be carried out in adequate time intervals to check the safety function. It is the user's responsibility to choose the type of testing.

You will find further instructions in the Safety Manual.

Implementation - Function test

The following options are available for carrying out the proof test (WHG, SIL):

1 Filling the vessel up to the switching point

If this does not cause any problems, you can fill the vessel up to the switching point and monitor the correct sensor reaction.

2 Dismounting of the sensor and immersion in the original medium

You can dismantle the sensor for test purposes and check its proper functioning by immersing it in the original product.

3 Short interruption of the supply line to the sensor

The recurring proof test according to IEC 61508 can be carried out through a short interruption (> 2 seconds) of the supply line to the sensor. This starts a test sequence.

The correctness of the subsequent switching conditions on the indications of the SPLC must be monitored. The sensor must neither be dismantled nor triggered by filling the vessel.

- Short interruption of the power supply
- Test key on SU 501 Ex - by monitoring the switching sequence of the test process

You can carry out the function test with the output current values also directly via a safety PLC or a process control system.

1 Filling the vessel up to the switching point

If this does not cause any problems, you can fill the vessel up to the switching point and monitor the correct sensor reaction.

Procedure

1. Carry out the function test according to the above description (1 Short interruption of the supply line to the sensor.
Separate the instrument briefly (> 2 s) from voltage supply or push the test key.

Check the results of the test.

Make sure the connected downstream devices are activated during the function test.

2. Push the mode switch (min./max.) on the controller.

Check if the switching status changes (signal lamp - switching status). By doing so, you can check the function of the measuring system.

If this is not the case, then there is a fault in the measuring system.

Make sure the connected downstream devices are activated during the function test.

3. Fill the vessel up to the switching point.

Check if the switching status changes (signal lamp - switching status). By doing so, you can check the function of the measuring system.

If this is not the case, then there is a fault in the measuring system.

Make sure the connected downstream devices are activated during the function test.

You can find the coverage of the test in the Safety Manual.

2 Dismounting of the sensor and immersion in the original medium

You can dismount the sensor for test purposes and check its function by immersing the vibrating element in the original medium.

Procedure

1. Carry out the function test according to the above description (1 Short interruption of the supply line to the sensor.

Separate the instrument briefly (> 2 s) from voltage supply or push the test key.

Check the results of the test.

Make sure the connected downstream devices are activated during the function test.

2. Push the mode switch (min./max.) on the controller.

Check if the switching status changes (signal lamp - switching status). By doing so, you can check the function of the measuring system.

If this is not the case, then there is a fault in the measuring system.

Make sure the connected downstream devices are activated during the function test.

3. Dismount the instrument and immerse the vibrating element up to the switching point in the original medium.

Check if the switching status changes (signal lamp - switching status). By doing so, you can check the function of the measuring system.

If this is not the case, then there is a fault in the measuring system.

Make sure the connected downstream devices are activated during the function test.

You can find the coverage of the test in the Safety Manual.

3 Short interruption of the supply line to the sensor

This test is valid if you cannot change the vessel filling or cannot dismount the sensor.

This function test can be carried out with measurement setups in conjunction with the two-wire electronics module.

The recurring proof test according to IEC 61508 can be carried out through a short interruption (> 2 seconds) of the supply line to the sensor.

By doing so, a test procedure is started. The correctness of the subsequent switching conditions on the indications of the SPLC must be monitored.

a. Short interruption of the supply line to the sensor

You can carry out the function test with the output current values also directly via a safety PLC or a process control system.

1. Separate the instrument briefly (> 2 s) from voltage supply.

Check if all three switching conditions change in the correct sequence and the specified duration. By doing so, you can check the function of the measuring system.

You can find the test procedure under "*Implementation - Function test*".

Make sure the connected downstream devices are activated during the function test.

2. Push the mode switch (min./max.) on the controller.

Check if the switching status changes (signal lamp - switching status). By doing so, you can check the function of the measuring system.

If this is not the case, then there is a fault in the measuring system.

Make sure the connected downstream devices are activated during the function test.

b. Pushing the test key

An integrated test key is lowered in the front plate of the controller or in the electronics module of the OPTISWITCH 5200 C, 5250 C. Push the test key for > 2 seconds with a suitable object.

1. Push the test key.

Check if all three switching conditions change in the correct sequence and the specified duration. By doing so, you can check the function of the measuring system.

You can find the test procedure under "*Implementation - Function test*".

Make sure the connected downstream devices are activated during the function test.

2. Push the mode switch (min./max.) on the controller.

Check if the switching status changes (signal lamp - switching status). By doing so, you can check the function of the measuring system.

If this is not the case, then there is a fault in the measuring system.

Make sure the connected downstream devices are activated during the function test.

Implementation - Function test

If you are using a controller of type SU 501 Ex for this purpose, you can also carry out the test with the integrated test key. The test key is recessed in the front plate of the controller. Push the test key for > 2 seconds with a suitable object (screwdriver, pen, etc.).

When the OPTISWITCH 5200 C, 5250 C is connected to a processing system or an SPLC, you have to interrupt the connection cable to the sensor for > 2 seconds. The switching delay must be set to 0.5 s.

After releasing the test key or interrupting the connection cable to the sensor, the complete measuring system can be checked on correct function. The following operating conditions are simulated during the test:

- Fault message
- Empty signal
- Full signal

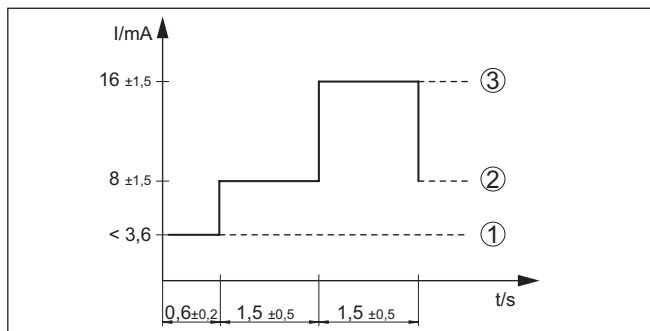

Fig. 14: Flow chart of the function test (mode "A")

- 1 Fault message
- 2 Empty signal
- 3 Full signal

Check if all three switching conditions occur in the correct sequence and the stated time period. If this is not the case, there is a fault in the measuring system (see also the operating instructions manual of the controller). Keep in mind that connected instruments are activated during the function test. By doing this, you can check the correct function of the measuring system.







Note:

Keep in mind that the starting time t_A of the voltage supply can extend the time up to the first switching (e.g. type SU 501 Ex: +1 s)

Test procedure

After releasing the button or after a brief line break.

	Sensor current - Sensor	Level relay A - overflow protection	Signal lamp A - Overflow protection	Level relay B - dry run protection	Signal lamp B - Dry run protection	Fail safe relay	Control lamp
1. Fault signal 0.6 s (±0,2 s) + t _A ¹⁾	< 3.6 mA	currentless	○	currentless	○	currentless	
2. Empty signal 1.5 s (±0.5 s)	8 mA (±1.5 mA)	energized		currentless	○	energized	○
3. Full signal 1.5 s (±0.5 s)	16 mA (±1.5 mA)	currentless	○	energized		energized	○
4. Return to current operating condition	-	-	-	-	-	-	

Test assessment (SPLC)**Test passed**

Status	Current value	Time
False signal	< 3.6 mA	0.6 s (±0.2 s)
Uncovered	8 mA (±1.5 mA)	1.5 s (±0.5 s)
Covered	16 mA (±1.5 mA)	1.5 s (±0.5 s)

1) Starting time of the voltage supply

7 Maintenance and fault rectification

7.1 Maintenance

Maintenance

If the device is used properly, no special maintenance is required in normal operation.

Cleaning

The cleaning helps that the type label and markings on the instrument are visible.

Take note of the following:

- Use only cleaning agents which do not corrode the housings, type label and seals
- Use only cleaning methods corresponding to the housing protection rating

7.2 Rectify faults

Reaction when malfunction occurs

The operator of the system is responsible for taking suitable measures to rectify faults.

Causes of malfunction

The device offers maximum reliability. Nevertheless, faults can occur during operation. These may be caused by the following, e.g.:

- Sensor
- Process
- Voltage supply
- Signal processing

Fault rectification

The first measure to take is to check the output signal. In many cases, the causes can be determined this way and the faults quickly rectified.

Checking the switching signal

Error	Cause	Rectification
OPTISWITCH 5200 C, 5250 C signals "covered" without being submerged (overflow protection) OPTISWITCH 5200 C, 5250 C signals "uncovered" when being submerged (dry run protection)	Operating voltage too low	Check operating voltage
	Electronics defective	Press the mode switch on the controller. If the instrument then changes the mode, the vibrating element may be covered with buildup or mechanically damaged. Should the switching function in the correct mode still be faulty, return the instrument for repair.
		Press the mode switch on the controller. If the instrument then does not change the mode, the electronics module is defective. Exchange the electronics module.
	Unfavourable installation location	Mount the instrument at a location in the vessel where no dead zones or air bubbles can form.
	Buildup on the vibrating element	Check the vibrating element and the sensor for buildup and remove the buildup if there is any.
Wrong mode selected	Set the correct mode on the controller (overflow protection, dry run protection). Wiring should be carried out according to the idle current principle.	

Error	Cause	Rectification
Control lamp off	Error on the vibrating element	Check if the vibrating element is damaged or extremely corroded.
	Interference on the electronics module	Exchanging the electronics module
	instrument defective	Exchange the instrument or send it in for repair

Reaction after fault rectification

Depending on the reason for the fault and the measures taken, the steps described in chapter "Setup" must be carried out again or must be checked for plausibility and completeness.

7.3 Exchanging the electronics

If the electronics module is defective, it can be replaced by the user.



In Ex applications only an electronics module with respective Ex approval may be used.

You can find all the information you need to carry out an electronics exchange in the handbook of the new electronics module.

In general, all electronics modules of series SW60 can be interchanged. If you want to use an electronics module with a different signal output, you carry out the complete setup. You find the necessary, suitable operating instruction on our homepage.



Note:

Keep in mind that enamelled instrument versions need special electronics modules. These electronics modules are called SW60E or SW60E1.

7.4 How to proceed if a repair is necessary

If it is necessary to repair the instrument, please contact the responsible Krohne agency.

8 Dismount

8.1 Dismounting steps

**Warning:**

Before dismounting, be aware of dangerous process conditions such as e.g. pressure in the vessel, high temperatures, corrosive or toxic products etc.

Take note of chapters "*Mounting*" and "*Connecting to voltage supply*" and carry out the listed steps in reverse order.



With Ex instruments, the housing cover may only be opened if there is no explosive atmosphere present.

8.2 Disposal

The device is made of recyclable materials. For this reason, it should be disposed of by a specialist recycling company. Observe the applicable national regulations.

9 Supplement

9.1 Technical data

Note for approved instruments

The technical data in the respective safety instructions which are included in delivery are valid for approved instruments (e.g. with Ex approval). These data can differ from the data listed herein, for example regarding the process conditions or the voltage supply.

All approval documents can be downloaded from our homepage.

General data

Material 316L corresponds to 1.4404 or 1.4435

Materials, wetted parts

- | | |
|--|---|
| – Process fitting - thread | 316L, Alloy C22 (2.4602) |
| – Process fitting - flange | 316L, 316L with Alloy C22 (2.4602) coating, steel enamelled, 316L with ECTFE coating, 316L with PFA coating |
| – Process seal | Klingersil C-4400 |
| – Tuning fork | 316L, Alloy C22 (2.4602), Alloy C4 (2.4610) enamelled |
| – Extension tube: \varnothing 21.3 mm (0.839 in) | 316L, Alloy C22 (2.4602), Alloy C22 (2.4602) enamelled, 316L with ECTFE coating, 316L with PFA coating |

Materials, non-wetted parts

- | | |
|---|--|
| – Plastic housing | Plastic PBT (Polyester) |
| – Aluminium die-cast housing | Aluminium die-casting AlSi10Mg, powder-coated (Basis: Polyester) |
| – Stainless steel housing (precision casting) | 316L |
| – Stainless steel housing (electropolished) | 316L |
| – Seal between housing and housing lid | Silicone SI 850 R |
| – Seal between housing and housing cover (lacquer-compatible version) | EPDM |
| – Optical fibre in housing cover | PMMA (Makrolon) |
| – Ground terminal | 316L |
| – Cable gland | PA, stainless steel, brass |
| – Sealing, cable gland | NBR |
| – Blind plug, cable gland | PA |
| – Temperature adapter (optional) | 316L |

Second Line of Defense resp. gas-tight leadthrough (optional)

- | | |
|--|------|
| – The Second Line of Defense (SLOD) is a second level of the process separation in the form of a gas-tight feedthrough in the lower part of the housing, preventing product from penetrating into the housing. | |
| – Supporting material | 316L |

– Glass potting	Borosilicate glass (Schott no. 8421)
– Contacts	1.4101
– Helium leak rate	< 10 ⁻⁶ mbar l/s
– Pressure resistance	PN 64
Sensor length (L)	
– 316L, Alloy C22 (2.4602)	80 ... 6000 mm (3.15 ... 236.22 in)
– Alloy C22 (2.4602) enamelled	80 ... 1500 mm (3.15 ... 59.055 in)
– 316L, ECTFE coated	80 ... 3000 mm (3.15 ... 118.11 in)
– 316L, PFA coated	80 ... 4000 mm (3.15 ... 157.48 in)
– Sensor lengths - accuracy	± 2 mm (± 0.079 in)
Tube diameter	ø 21.3 mm (0.839 in)
Weight	
– Instrument weight (depending on process fitting)	approx. 0.8 ... 4 kg (0.18 ... 8.82 lbs)
– Tube extension	approx. 920 g/m (9.9 oz/ft)
Layer thickness	
– Enamel	600 µm ±200 µm (0.024 in ±0.008 in)
– ECTFE	500 µm +500/-200 µm (0.02 in +0.02/-0.008 in)
– PFA	600 µm +500/-300 µm (0.024 in +0.02/-0.012 in)
Surface quality	
– Standard	R _a approx. 3 µm (1.18 ⁻⁴ in)
– Hygienic version 3A (OPTISWITCH 5250 C)	R _a < 0.8 µm (3.15 ⁻⁵ in)
– Hygienic version 3A (OPTISWITCH 5250 C)	R _a < 0.3 µm (1.18 ⁻⁵ in)
Process fittings	
– Pipe thread, cylindrical (DIN 3852-A)	G ³ / ₄ , G1
– Pipe thread, conical (ASME B1.20.1)	³ / ₄ NPT, 1 NPT
– Flanges	DIN from DN 25, ASME from 1"
– hygienic fittings	Slotted nut DN 40 PN 40, Clamp 1" DIN 32676 ISO 2852/316L, Clamp 2" DIN 32676 ISO 2852/316L, conus DN 25 PN 40, Tuchenhausen Varivent DN 50 PN 10
Max. torque - process fitting	
– Thread G ³ / ₄ , ³ / ₄ NPT	75 Nm (55 lbf ft)
– Thread G1, 1 NPT	100 Nm (73 lbf ft)
Torque for NPT cable glands and Conduit tubes	
– Plastic housing	max. 10 Nm (7.376 lbf ft)
– Aluminium/Stainless steel housing	max. 50 Nm (36.88 lbf ft)
High voltage test (enamel)	max. 5 KV
Gas-tight leadthrough (optional)	
– Leakage rate	< 10 ⁻⁶ mbar l/s

– Pressure resistance PN 64

Output variable

Output Two-wire output

Output signal

- empty (uncovered) 8 mA
- full (covered) 16 mA
- Fault message < 1.8 mA

Possible controllers VEGATOR 121, VEGATOR 122

Modes (adjustable via the controller)

- A Max. detection or overflow/overflow protection
- B Min. detection or dry run protection

Measurement accuracy (according to DIN EN 60770-1)

Reference conditions and influencing variables (according to DIN EN 61298-1)

- Ambient temperature +18 ... +30 °C (+64 ... +86 °F)
- Relative humidity 45 ... 75 %
- Air pressure 860 ... 1060 mbar/86 ... 106 kPa (12.5 ... 15.4 psig)
- Product temperature +18 ... +30 °C (+64 ... +86 °F)
- Product density 1 g/cm³ (0.036 lbs/in³) (water)
- Product viscosity 1 mPa s
- Superimposed pressure 0 kPa
- Sensor installation Vertically from top
- Density selection switch ≥ 0.7 g/cm³

Measurement accuracy

Deviation ± 1 mm (0.04 in)

Influence of the process temperature on the switching point

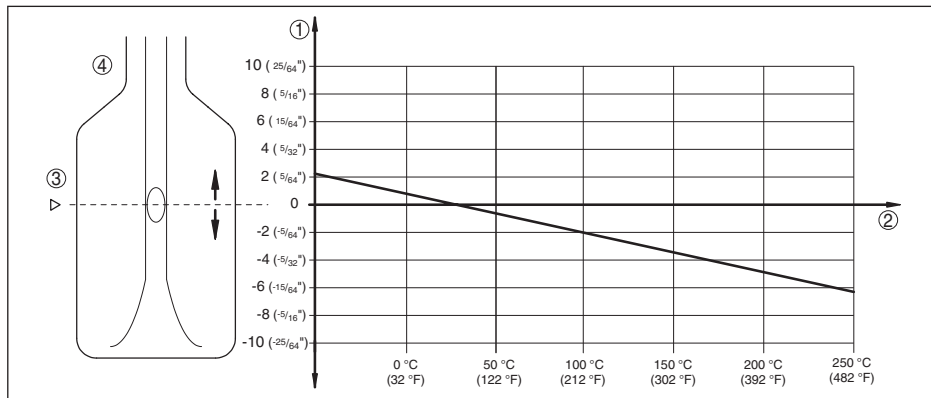

Fig. 15: Influence of the process temperature on the switching point

- 1 Shifting of the switching point in mm (in)
- 2 Process temperature in °C (°F)
- 3 Switching point at reference conditions (notch)
- 4 Tuning fork

Influence of the product density on the switching point

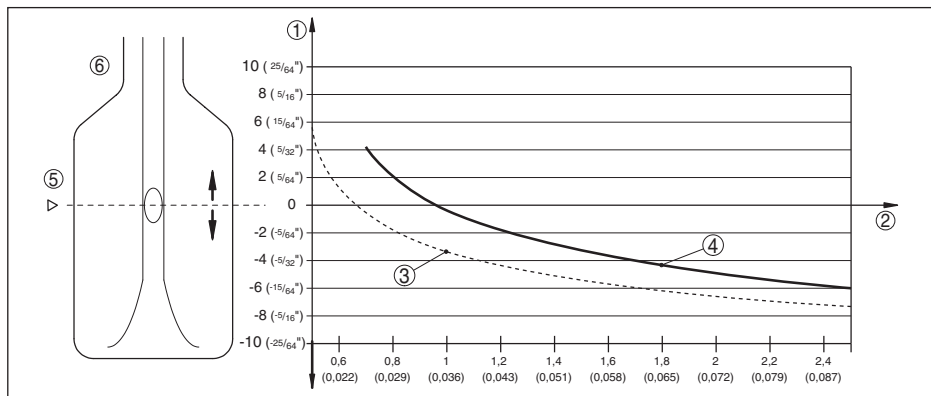

Fig. 16: Influence of the product density on the switching point

- 1 Shifting of the switching point in mm (in)
- 2 Product density in g/cm³ (lb/in³)
- 3 Switch position $\geq 0.5 \text{ g/cm}^3$ (0.018 lb/in³)
- 4 Switch position $\geq 0.7 \text{ g/cm}^3$ (0.025 lb/in³)
- 5 Switching point at reference conditions (notch)
- 6 Tuning fork

Influence of the process pressure to the switching point

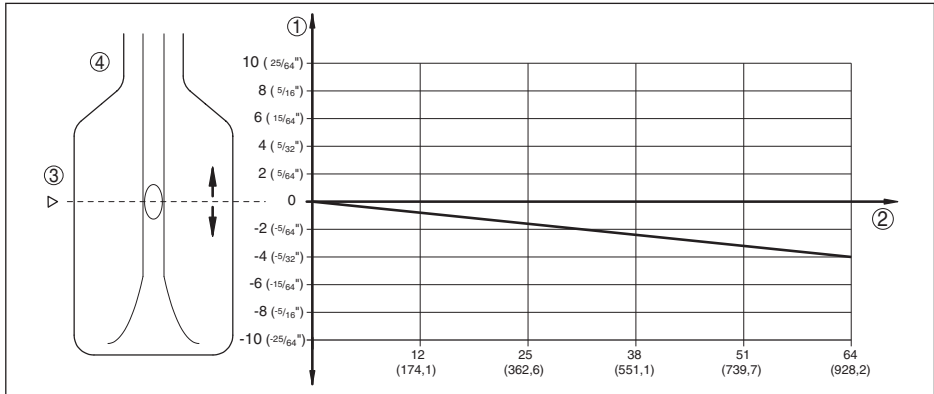

Fig. 17: Influence of the process pressure to the switching point

- 1 Shifting of the switching point in mm (in)
- 2 Process pressure in bar (psig)
- 3 Switching point at reference conditions (notch)
- 4 Tuning fork

Non-repeatability	0.1 mm (0.004 in)
Hysteresis	approx. 2 mm (0.08 in) with vertical installation
Switching delay	approx. 500 ms (on/off)
Measuring frequency	approx. 1200 Hz

Ambient conditions

Ambient temperature on the housing	-40 ... +70 °C (-40 ... +158 °F)
Storage and transport temperature	-40 ... +80 °C (-40 ... +176 °F)

Process conditions

Measured variable	Limit level of liquids
Process pressure	-1 ... 64 bar/-100 ... 6400 kPa (-14.5 ... 928 psig) The process pressure is dependent on the process fitting, for example Clam p or flange (see the following diagrams)
Maximum allowable operating pressure	100 bar/10000 kPa (1450 psig) or 1.5 times process pressure The function of the instrument is ensured up to an operating pressure of 100 bar/10000 kPa (1450 psig) at a maximum process temperature of +50 °C (+122 °F) (only with threaded versions).
Process temperature (thread or flange temperature)	
- OPTISWITCH 5200 C, 5250 C of 316L/Alloy C22 (2.4602)	-50 ... +150 °C (-58 ... +302 °F)

Process temperature (thread or flange temperature) with temperature adapter (option)

- OPTISWITCH 5200 C, 5250 C of 316L/Alloy C22 (2.4602) -50 ... +250 °C (-58 ... +482 °F)
- OPTISWITCH 5200 C, 5250 C enamelled -50 ... +200 °C (-58 ... +392 °F)
- OPTISWITCH 5200 C, 5250 C with ECTFE coating -50 ... +150 °C (-58 ... +302 °F)
- OPTISWITCH 5200 C, 5250 C with PFA coating -50 ... +250 °C (-58 ... +482 °F)

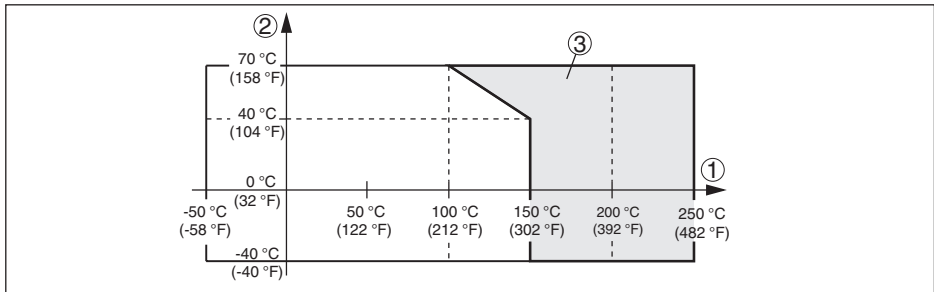

Fig. 18: Ambient temperature - Process temperature

- 1 Process temperature in °C (°F)
- 2 Ambient temperature in °C (°F)
- 3 Temperature range with temperature adapter

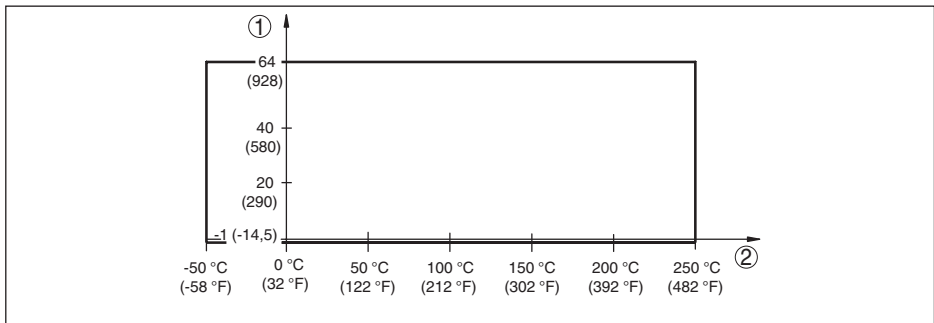

Fig. 19: Process temperature - Process pressure with switch position $\geq 0.7 \text{ g/cm}^3$ (sensitivity switch)

- 1 Process pressure in bar (psig)
- 2 Process temperature in °C (°F)

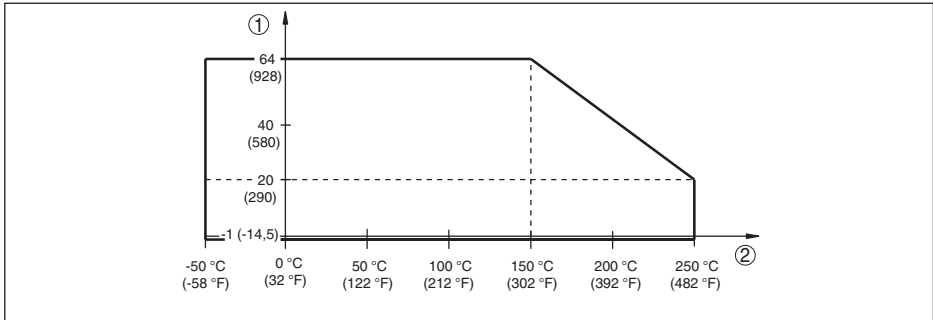

Fig. 20: Process temperature - Process pressure with switch position $\geq 0.5 \text{ g/cm}^3$ (sensitivity switch)

- 1 Process pressure in bar (psig)
2 Process temperature in °C (°F)

SIP process temperature (SIP = Sterilization in place)

PFA and ECTFE coatings are not suitable for SIP cleaning

Vapour stratification up to 2 h +150 °C (+302 F)

Additional process conditions

Viscosity - dynamic 0.1 ... 10000 mPa s (requirement: with density 1)

Flow velocity max. 6 m/s (with a viscosity of 10000 mPa s)

Density

- Standard sensitivity 0.7 ... 2.5 g/cm³ (0.025 ... 0.09 lbs/in³)
- High sensitivity 0.5 ... 2.5 g/cm³ (0.018 ... 0.09 lbs/in³)

Vibration resistance

- Instrument housing 1 g at 5 ... 200 Hz according to EN 60068-2-6 (vibration with resonance)
- Sensor 1 g with 5 ... 200 Hz according EN 60068-2-6 (vibration at resonance) with sensor length up to 50 cm (19.69 in)
With a sensor length > 50 cm (19.69 in) you have to fix the extension tube with a suitable support. See mounting instructions.

Electromechanical data

Options of the cable entry

- Cable entry M20 x 1.5; ½ NPT
- Cable gland M20 x 1.5; ½ NPT
- Blind plug M20 x 1.5; ½ NPT
- Closing cap ½ NPT

Screw terminals for wire cross-section up to 1.5 mm² (AWG 16)

Adjustment elements

Sensitivity switch

- $\geq 0.5 \text{ g/cm}^3$ 0.5 ... 2.5 g/cm³ (0.018 ... 0.09 lbs/in³)
- $\geq 0.7 \text{ g/cm}^3$ 0.7 ... 2.5 g/cm³ (0.025 ... 0.09 lbs/in³)

Voltage supply

Operating voltage (via the signal conditioning instrument)

- Non-Ex instrument	12 ... 36 V DC
- Ex-d instrument (ATEX, FM, CSA)	12 ... 36 V DC
- Ex-ia instrument (ATEX)	12 ... 29 V DC
- Ex-ia instrument (FM, CSA)	12 ... 31 V DC

Electrical protective measures

Protection rating	IP66/IP67 acc. to IEC 60529, Type 4X acc. to NEMA
Protection class	II

Approvals

Depending on the version, instruments with approvals can have different technical data. For these instruments, please note the corresponding approval documents. They are included in the scope of delivery.

9.2 Dimensions

OPTISWITCH 5200 C, 5250 C, housing

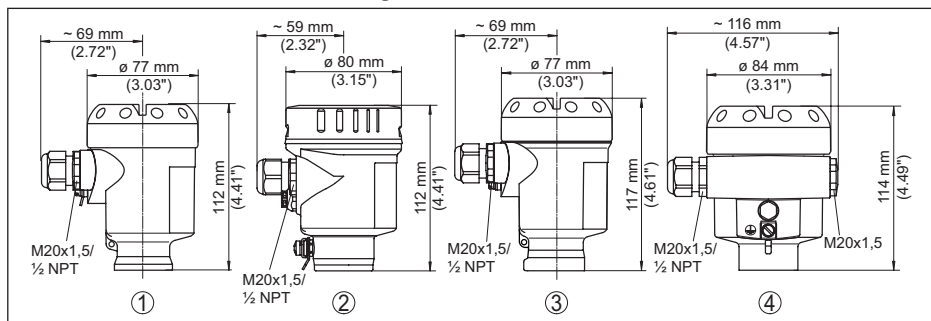

Fig. 21: Housing versions

- 1 Plastic housing
- 2 Stainless steel housing (electropolished)
- 3 Stainless steel housing (precision casting)
- 4 Aluminium housing

OPTISWITCH 5200 C, 5250 C

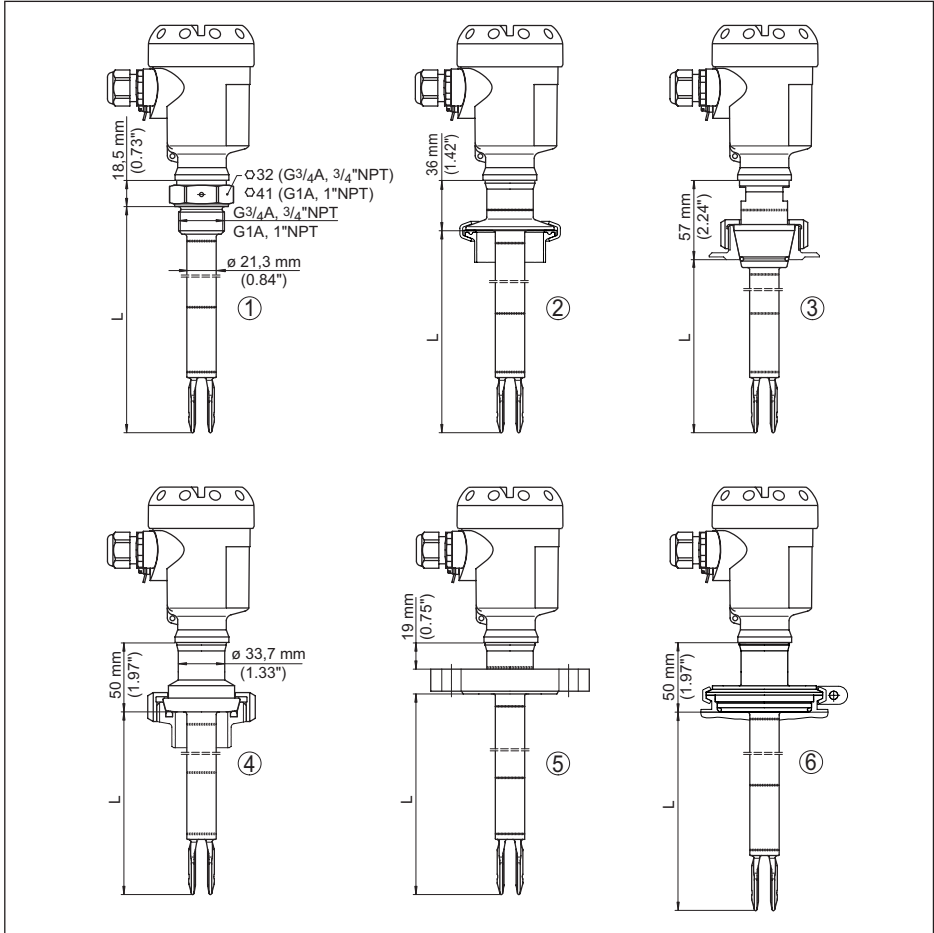

Fig. 22: OPTISWITCH 5200 C, 5250 C

- 1 Thread
- 2 Clamp
- 3 Cone DN 25
- 4 Slotted nut DN 40
- 5 Flange
- 6 Tuchenhagen Varivent
- L = Sensor length, see chapter "Technical data"

OPTISWITCH 5200 C, 5250 C, options

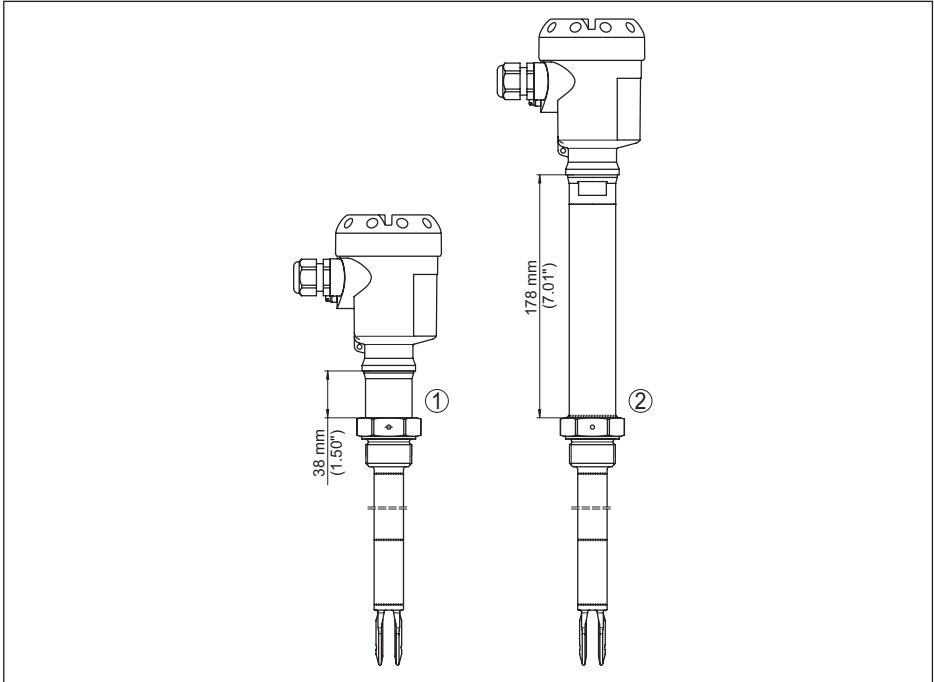

Fig. 23: Options

- 1 Gas-tight leadthrough
- 2 Temperature adapter

9.3 Trademark

All the brands as well as trade and company names used are property of their lawful proprietor/originator.

A large grid of graph paper for taking notes, consisting of 20 columns and 30 rows of small squares.

30435-EN-210701

KROHNE - Products, Solutions and Services

- Process instrumentation for flow, level, temperature, pressure measurement and process analytics
- Flow metering, monitoring, wireless and remote metering solutions
- Engineering, commissioning, calibration, maintenance and training services

Head Office KROHNE Messtechnik GmbH
Ludwig-Krohne-Straße 5
47058 Duisburg (Germany)
Tel.: +49 (0) 203 301 0
Tel.: +49 (0) 203 301 10389
info@krohne.de

The current list of all KROHNE contacts and addresses can be found at:
www.krohne.com

KROHNE