



## SD 200 W/R Handbook

Loop powered indicator

(SW.REV. 03.01.x)

All rights reserved. It is prohibited to reproduce this documentation, or any part thereof, without the prior written authorisation of KROHNE Messtechnik GmbH.

Subject to change without notice.

Copyright 2020 by  
KROHNE Messtechnik GmbH - Ludwig-Krohne-Str. 5 - 47058 Duisburg (Germany)

<b>1</b>	<b>Safety instructions</b>	<b>5</b>
<hr/>		
1.1	Intended use .....	5
1.2	Certifications .....	5
1.3	Safety instructions from the manufacturer .....	6
1.3.1	Copyright and data protection .....	6
1.3.2	Disclaimer .....	6
1.3.3	Product liability and warranty .....	7
1.3.4	Information concerning the documentation .....	7
1.3.5	Warnings and symbols used .....	8
1.4	Safety instructions for the operator .....	8
<b>2</b>	<b>Device description</b>	<b>9</b>
<hr/>		
2.1	Scope of delivery .....	9
2.2	Device description .....	10
2.2.1	SD 200 W .....	10
2.2.2	SD 200 R .....	10
2.3	Nameplate SD 200 R .....	11
2.4	Nameplate SD 200 W .....	12
<b>3</b>	<b>Installation</b>	<b>13</b>
<hr/>		
3.1	General notes on installation .....	13
3.2	Storage and transport .....	13
3.3	Installation .....	14
3.4	Connection with junction box SJB 200 W .....	15
3.5	Connection without SJB 200 W (only with wall mounting version SD 200 W) .....	17
3.6	Grounding and equipotential bonding .....	17
<b>4</b>	<b>Start-up</b>	<b>18</b>
<hr/>		
4.1	Switching on the power .....	18
4.2	Operation keys .....	18
4.3	Information and functions .....	19
4.4	Configuration .....	19
4.5	Overview functions setup level .....	21
4.6	Explanation of the setup function .....	21
<b>5</b>	<b>Service</b>	<b>24</b>
<hr/>		
5.1	Maintenance .....	24
5.2	Availability of services .....	24
5.3	Returning the device to the manufacturer .....	25
5.3.1	General information .....	25
5.3.2	Form (for copying) to accompany a returned device .....	26
5.4	Disposal .....	26

6 Technical data	27
6.1 Technical data.....	27
6.2 Dimensions.....	29
7 Notes	30

## 1.1 Intended use

**CAUTION!**

Responsibility for the use of the measuring devices with regard to suitability, intended use and corrosion resistance of the used materials against the measured fluid lies solely with the operator.

**INFORMATION!**

This device is a Group 1, Class A device as specified within CISPR11:2009. It is intended for use in industrial environment. There may be potential difficulties in ensuring electromagnetic compatibility in other environments, due to conducted as well as radiated disturbances.

**INFORMATION!**

The manufacturer is not liable for any damage resulting from improper use or use for other than the intended purpose.

The intended use of the indicator SD 200 W/R is to display the actual value such as pH, ORP and conductive conductivity.

## 1.2 Certifications

CE marking



The device fulfils the statutory requirements of the following EC directives:

- EMC Directive 2014/30/EU

The manufacturer certifies successful testing of the product by applying the CE marking.

## 1.3 Safety instructions from the manufacturer

### 1.3.1 Copyright and data protection

The contents of this document have been created with great care. Nevertheless, we provide no guarantee that the contents are correct, complete or up-to-date.

The contents and works in this document are subject to copyright. Contributions from third parties are identified as such. Reproduction, processing, dissemination and any type of use beyond what is permitted under copyright requires written authorisation from the respective author and/or the manufacturer.

The manufacturer tries always to observe the copyrights of others, and to draw on works created in-house or works in the public domain.

The collection of personal data (such as names, street addresses or e-mail addresses) in the manufacturer's documents is always on a voluntary basis whenever possible. Whenever feasible, it is always possible to make use of the offerings and services without providing any personal data.

We draw your attention to the fact that data transmission over the Internet (e.g. when communicating by e-mail) may involve gaps in security. It is not possible to protect such data completely against access by third parties.

We hereby expressly prohibit the use of the contact data published as part of our duty to publish an imprint for the purpose of sending us any advertising or informational materials that we have not expressly requested.

### 1.3.2 Disclaimer

The manufacturer will not be liable for any damage of any kind by using its product, including, but not limited to direct, indirect or incidental and consequential damages.

This disclaimer does not apply in case the manufacturer has acted on purpose or with gross negligence. In the event any applicable law does not allow such limitations on implied warranties or the exclusion of limitation of certain damages, you may, if such law applies to you, not be subject to some or all of the above disclaimer, exclusions or limitations.

Any product purchased from the manufacturer is warranted in accordance with the relevant product documentation and our Terms and Conditions of Sale.

The manufacturer reserves the right to alter the content of its documents, including this disclaimer in any way, at any time, for any reason, without prior notification, and will not be liable in any way for possible consequences of such changes.

### 1.3.3 Product liability and warranty

The operator shall bear responsibility for the suitability of the device for the specific purpose. The manufacturer accepts no liability for the consequences of misuse by the operator. Improper installation or operation of the devices (systems) will cause the warranty to be void. The respective "Standard Terms and Conditions" which form the basis for the sales contract shall also apply.

### 1.3.4 Information concerning the documentation

To prevent any injury to the user or damage to the device it is essential that you read the information in this document and observe applicable national standards, safety requirements and accident prevention regulations.

If this document is not in your native language and if you have any problems understanding the text, we advise you to contact your local office for assistance. The manufacturer can not accept responsibility for any damage or injury caused by misunderstanding of the information in this document.

This document is provided to help you establish operating conditions, which will permit safe and efficient use of this device. Special considerations and precautions are also described in the document, which appear in the form of icons as shown below.

### 1.3.5 Warnings and symbols used

Safety warnings are indicated by the following symbols.



**DANGER!**

*This warning refers to the immediate danger when working with electricity.*



**DANGER!**

*This warning refers to the immediate danger of burns caused by heat or hot surfaces.*



**DANGER!**

*This warning refers to the immediate danger when using this device in a hazardous atmosphere.*



**DANGER!**

*These warnings must be observed without fail. Even partial disregard of this warning can lead to serious health problems and even death. There is also the risk of seriously damaging the device or parts of the operator's plant.*



**WARNING!**

*Disregarding this safety warning, even if only in part, poses the risk of serious health problems. There is also the risk of damaging the device or parts of the operator's plant.*



**CAUTION!**

*Disregarding these instructions can result in damage to the device or to parts of the operator's plant.*



**INFORMATION!**

*These instructions contain important information for the handling of the device.*



**LEGAL NOTICE!**

*This note contains information on statutory directives and standards.*



• **HANDLING**

This symbol designates all instructions for actions to be carried out by the operator in the specified sequence.

➔ **RESULT**

This symbol refers to all important consequences of the previous actions.

## 1.4 Safety instructions for the operator



**WARNING!**

*In general, devices from the manufacturer may only be installed, commissioned, operated and maintained by properly trained and authorized personnel.  
This document is provided to help you establish operating conditions, which will permit safe and efficient use of this device.*



## 2.1 Scope of delivery

**INFORMATION!**

Inspect the packaging carefully for damages or signs of rough handling. Report damage to the carrier and to the local office of the manufacturer.

**INFORMATION!**

Do a check of the packing list to make sure that you have all the elements given in the order.

**INFORMATION!**

Look at the device nameplate to ensure that the device is delivered according to your order.

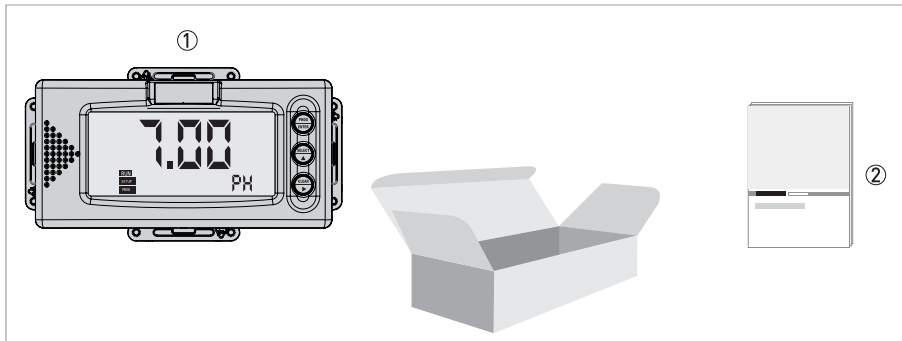

Figure 2-1: Standard scope of delivery

- ① Ordered indicator
- ② Documentation

## 2.2 Device description

### 2.2.1 SD 200 W

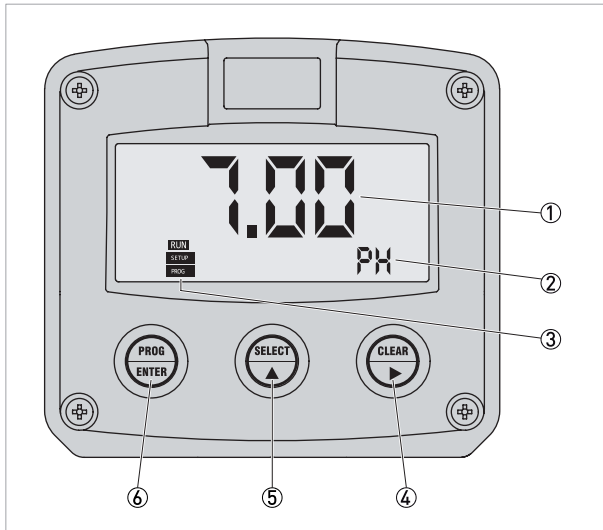

Figure 2-2: Construction of the indicator

- ① Measuring value
- ② Measuring parameter
- ③ Status information
- ④ Operation key CLEAR/ ▶
- ⑤ Operation key SELECT/ ▲
- ⑥ Operation key PROG/ENTER

### 2.2.2 SD 200 R

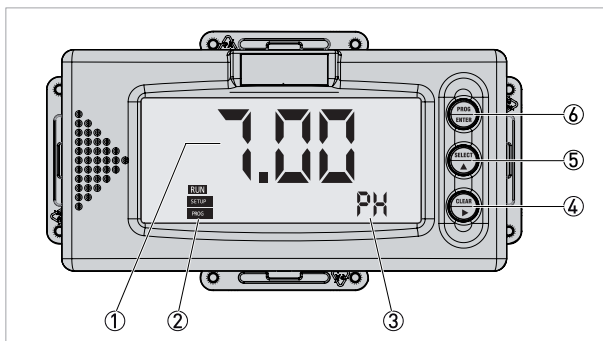

Figure 2-3: Construction of the indicator

- ① Measuring value
- ② Status information
- ③ Measuring parameter
- ④ Operation key CLEAR/ ▶
- ⑤ Operation key SELECT/ ▲
- ⑥ Operation key PROG/ENTER

## 2.3 Nameplate SD 200 R

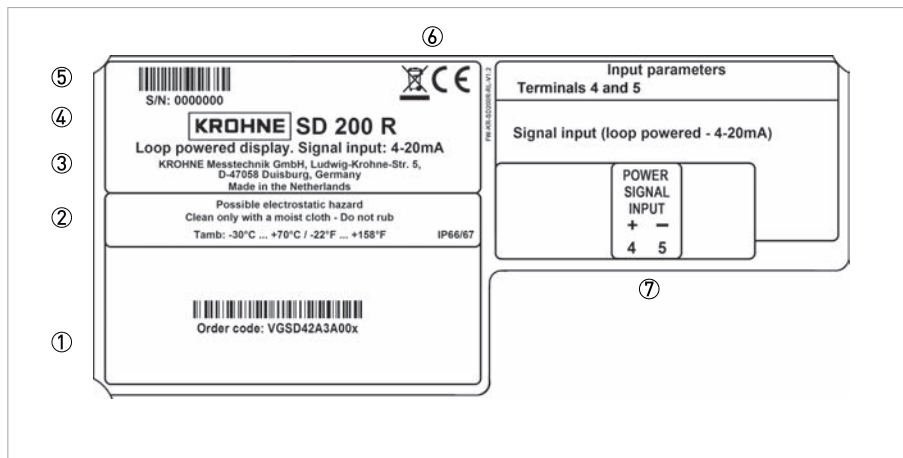

Figure 2-4: Example for a nameplate

- ① Order code
- ② Temperature ambient
- ③ Manufacturer
- ④ Device name
- ⑤ Serial number
- ⑥ CE marking
- ⑦ Power supply



### **INFORMATION!**

Look at the device nameplate to ensure that the device is delivered according to your order.

2.4 Nameplate SD 200 W

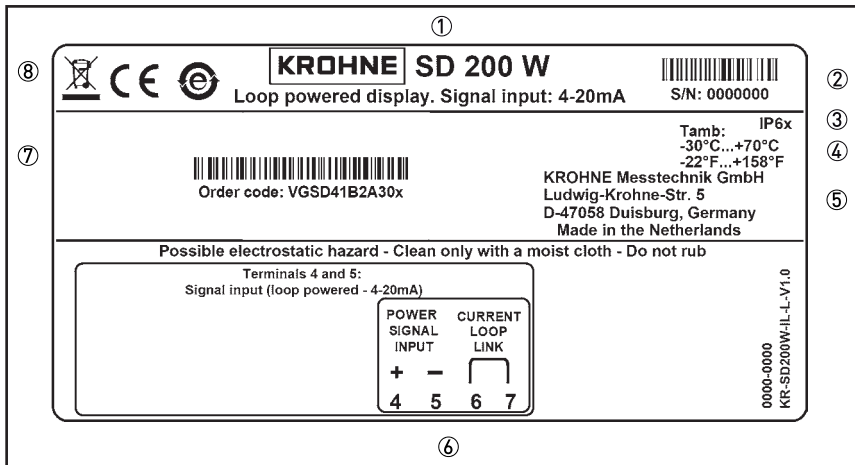

Figure 2-5: Example for a nameplate (inside)

- ① Product name
- ② Serial number
- ③ Ingress protection
- ④ Temperature ambient
- ⑤ Manufacturer
- ⑥ Power supply
- ⑦ Order code
- ⑧ CE marking

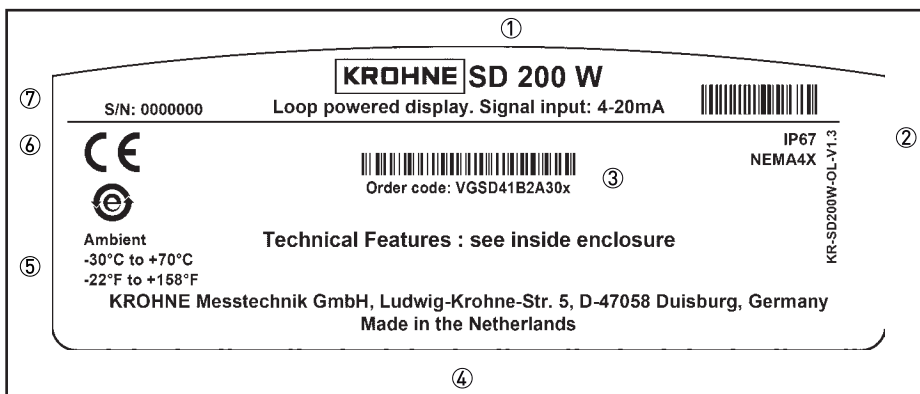

Figure 2-6: Example for a nameplate (outside)

- ① Product name
- ② Ingress protection
- ③ Order code
- ④ Manufacturer
- ⑤ Temperature ambient
- ⑥ CE marking
- ⑦ Serial number



**INFORMATION!**

Look at the device nameplate to ensure that the device is delivered according to your order.

### 3.1 General notes on installation

**DANGER!**

*For devices used in hazardous areas, additional safety notes apply; please refer to the Ex documentation.*

**DANGER!**

*Observe the national regulations for electrical installations!*

**DANGER!**

*All work on the electrical connections may only be carried out with the power disconnected.*

**DANGER!**

*Ensure that the measuring system is correctly wired up according to the wiring diagrams.*

**DANGER!**

*Protection against accidental contact is no longer assured when the housing cover is removed or the cabinet has been opened. The housing may only be opened by trained personnel.*

**WARNING!**

*During installation of the device make sure that you use ESD (electrostatic discharge) protection equipment.*

**WARNING!**

*Observe without fail the local occupational health and safety regulations. Any work done on the electrical components of the measuring device may only be carried out by properly trained specialists.*

**INFORMATION!**

*Inspect the packaging carefully for damages or signs of rough handling. Report damage to the carrier and to the local office of the manufacturer.*

**INFORMATION!**

*Do a check of the packing list to make sure that you have all the elements given in the order.*

**INFORMATION!**

*Look at the device nameplate to ensure that the device is delivered according to your order.*

### 3.2 Storage and transport

- Store and transport the device in a dry, dust-free location.
- Avoid continuous direct sunlight.
- Store and transport the device in its original packing.
- Storage temperature: -40...+80°C / -40...+176°F

### 3.3 Installation

**DANGER!**

*Never install or operate the device in potentially explosive areas, it might cause an explosion that can result in fatal injuries.*

**CAUTION!**

*Always note the following items to ensure a proper and safe installation:*

- *Make sure that there is adequate space to the sides.*
- *The device must not be heated by radiated heat (e.g. exposure to the sun) to a electronics housing surface temperature above the maximum permissible ambient temperature. If it is necessary to prevent damage from heat sources, a heat protection (e.g. sun shade) has to be installed.*
- *Do not expose the indicator to intense vibration.*
- *Indicator installed in control cabinets require adequate cooling, e.g. by fan or heat exchanger.*
- *Take the relevant IP classification of the enclosures into account (see manufactures plate). Even an IP67 (NEMA 4X) enclosure should NEVER be exposed to strongly varying (weather) conditions.*
- *When used in very cold surroundings or varying climatic conditions with high humidity (above 90% annual mean), take the necessary precautions against moisture by placing a dry sachet of silica gel, for example, inside the instrument case. Furthermore, it is required to replace or dry the silica gel periodically as advised by the silica gel supplier. For further information about the ambient temperature refer to Technical data on page 27.*
- *Use assembly materials and tools in compliance with the applicable occupational health and safety directives (assembly materials and tools are not part of the scope of delivery).*

**CAUTION!**

*Installation, assembly, start-up and maintenance may only be performed by appropriately trained personnel. The regional occupational health and safety directives must always be observed.*

**INFORMATION!**

*Assembly materials and tools are not part of the delivery. Use the assembly materials and tools in compliance with the applicable occupational health and safety directives.*

### 3.4 Connection with junction box SJB 200 W



**DANGER!**

For devices used in hazardous areas, additional safety notes apply; please refer to the Ex documentation.



**WARNING!**

Installation, assembly, start-up and maintenance may only be performed by personnel trained in **explosion protection**. Additional regional standards, safety directives and laws must be observed at all times.



**CAUTION!**

When connecting the power supply, always note the safety regulations of the current state of the art. To avoid fatal injuries, destruction or damage of the device or measuring errors, also note the following items:

- De-energise the cables of the power supply before you start any installation works.
- Always keep the housing of the device well closed if you do not perform any installation works. The function of the housing is to protect the electronic equipment from dust and moisture. When used in very cold surroundings or varying climatic conditions, take the necessary precautions against moisture by placing a dry sachet of silica gel, for example, inside the instrument case.
- Check the nameplate and assure that the power supply meets the voltage and frequency of the device.
- Separate cable glands with effective IP67 (NEMA4X) seals for all wires for SD 200 W indicator.
- Unused cable entries: ensure that you fit IP67 (NEMA4X) plugs to maintain rating.
- Use a shielded and grounded cable.



**INFORMATION!**

The device does not require a separate power supply. The required supply for the electronics is provided via the 4...20 mA current output.

Before you start to connect the power supply cables, note the following drawing with the function of the terminals:

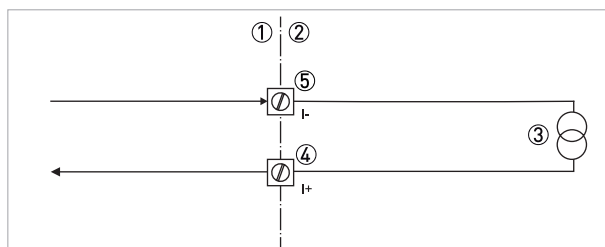

Figure 3-1: Overview terminal connections 4...20 mA input

- ① Internal
- ② External
- ③ Max. 30 V DC
- ④ Terminal connection I+
- ⑤ Terminal connection I-

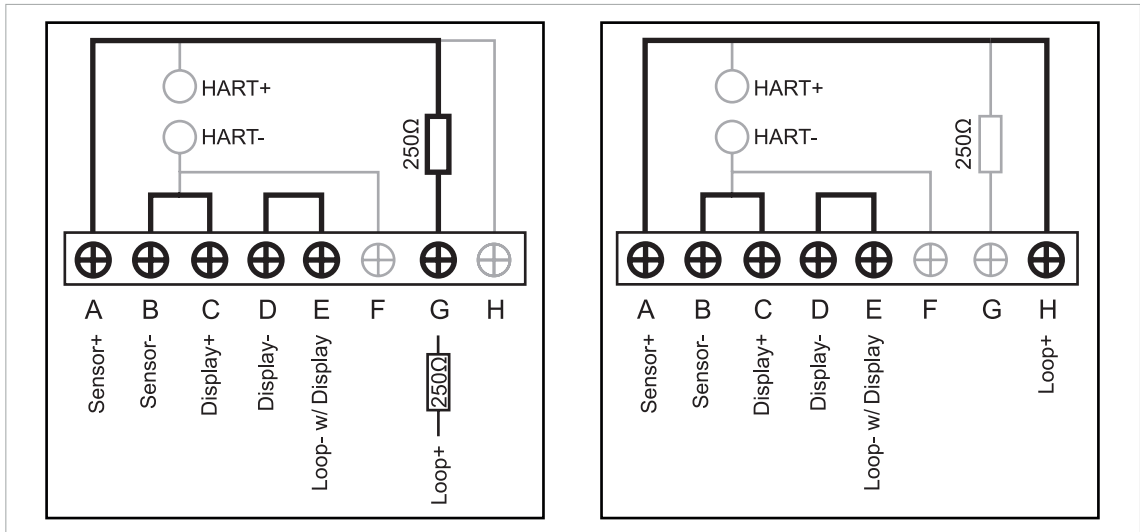

Figure 3-2: SJB 200 W with SMARTPAT sensor, integrated HART<sup>®</sup> resistor and display (left side). SJB 200 W with SMARTPAT sensor, display and without integrated HART<sup>®</sup> resistor (right side).

SJB 200 W with SMARTPAT sensor, integrated HART <sup>®</sup> resistor and display.		SJB 200 W with SMARTPAT sensor, display and without integrated HART <sup>®</sup> resistor.	
A	Sensor+ (Ub+)	A	Sensor+ (Ub+)
B	Sensor- (Ub-)	B	Sensor- (Ub-)
C	Display+	C	Display+
D	Display-	D	Display-
E	Loop- w/ Display	E	Loop- w/ Display
G	Loop+ 250Ω	H	Loop+



### 3.5 Connection without SJB 200 W (only with wall mounting version SD 200 W)

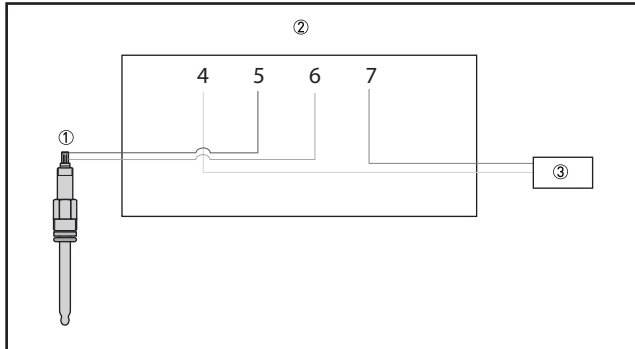

Figure 3-3: Connection without SJB 200 W (only with wall mounting version SD 200 W)

- ① Field device
- ② SD 200 W
- ③ Power supply / Control room

### 3.6 Grounding and equipotential bonding



**DANGER!**

*The housing must be connected to the equipotential bonding of the hazardous area. Please use the ground connection facility (terminal FE) inside the housing.*

The sensor cable shield must be connected to the connection facility (terminal S).

Consider the information mentioned in the supplementary instruction of the SMARTPAT sensor.

## 4.1 Switching on the power



### **DANGER!**

To avoid fatal injuries as well as destruction or damage of the device assure a correct installation before switching on the power. This includes:

- The device is mechanically safe, mounting and power connection comply with the regulations.
- The electrical terminal compartments must be secured, i.e. the housing has to be closed and the screws have to be tightened.
- The electrical operating data of the power supply comply with the requirements of the device.



### **CAUTION!**

Installation, assembly, start-up and maintenance may only be performed by appropriately trained personnel. The regional occupational health and safety directives must always be observed.

## 4.2 Operation keys

The following key are available

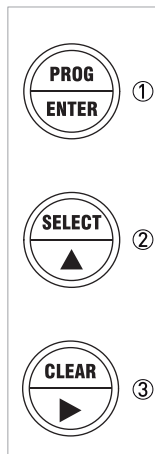

Figure 4-1: Operation keys

- ① This key has no function at Operator level.  
The key is used to program and save new values or settings. It is also used to gain access to SETUP-level
- ② This key has no function at Operator level.  
The arrow-key ▲ is used to increase a value after PROG has been pressed or to configure the unit
- ③ This key has no function at Operator level.  
The arrow-key ► is used to increase a value after PROG has been pressed or to configure the unit

## 4.3 Information and functions

In general, SD 200 W/R indicators will always act at operator level.

### Display value and measuring unit

- This is the main display information of the indicator. After selecting any other information, it will always return to this main display automatically.

### Under range / Over range

- If the current is in-between 3.5 mA and 3.75 mA the value “----” will be displayed.
- If the input current is in-between 3.75 mA and 4 mA the value corresponding to 4 mA will be displayed.
- If the input current is in-between 20 mA and 21.5 mA the value will be extrapolated while an message is displayed “RANGE ERROR”.
- If the input current is above 21.5 mA the value “9999” and “Error high” will be displayed.
- If the input current is above 25 mA the value “9999” and “Error SC” (short circuit) will be displayed.

## 4.4 Configuration

Configuration of the SD 200 W/R indicators is done at SETUP-level. SETUP-level is reached by pressing the PROG/ENTER key for 7 seconds; at which time, the indication “SETUP” will be displayed. In order to return to the operator level, PROG will have to be pressed for three seconds. Alternatively, if no keys are pressed for 2 minutes, the unit will exit SETUP automatically. SETUP can be reached at all times while the indicator remains fully operational.



### **INFORMATION!**

*A password may be required to enter SETUP. Without this password access to SETUP is denied.*



Press the key for 7 seconds to enter the SETUP-level

Selection of function-group and function: SETUP is divided into several function-groups and functions.



Select function-group with



Select function with

Each function has a unique number, which is displayed beside the word "SETUP" at the bottom of the indicator. This indicator has 2 functions-groups: 1 FUNCTION, 2 OTHERS. Press SELECT to select a function.



After selecting a sub-function, the next main function is selected by scrolling through all "active" sub-functions (e.g. 1▲, 11▲, 12▲, 13▲, 14▲, 1▲, 2▲ etc.).

Change or select a value:



- Press  briefly, PROG will start flash



- Select a value by pressing  or 



- Press  to confirm the value / selection

To change a value, use ▶ to select the digits and ▲ to increase that value. To select a setting, both ▲ and ▶ can be used.

When data is changed but ENTER is not pressed, then the modification can still be cancelled by waiting for 20 seconds or by pressing ENTER for three seconds: the PROG-procedure will be left automatically and the former value reinstated.



**INFORMATION!**

*Modification will only be set after ENTER has been pressed!*



To return to OPERATOR-level press  for 3 seconds.

In order to return to the operator level, PROG will have to be pressed for three seconds. Also, when no keys are pressed for 2 minutes, SETUP will be left automatically.

## 4.5 Overview functions setup level

Setup function and variables	
1	Function
11	Unit
12	Decimals
13	Offset
14	Span
15	Filter
16	Calibrate low
17	Calibrate high
2	Others
21	Model
22	Type
23	Software version
24	Serial No.
25	Password
26	Tag number

## 4.6 Explanation of the setup function

1 Function	
11 - Unit	<p><b>SETUP - 11 determines the measurement unit to be displayed. The following units can be selected:</b></p> <ul style="list-style-type: none"> <li>• Analysis-unit-package - pH, mV, mS/cm, <math>\mu</math>S/cm, <math>k\Omega \cdot \text{cm}</math>, <math>M\Omega \cdot \text{cm}</math></li> <li>• Multiparameter-unit-package - pH, mV, mS/cm, <math>\mu</math>S/cm, <math>k\Omega \cdot \text{cm}</math>, <math>M\Omega \cdot \text{cm}</math>, °C, °F, °K, g/l, mg/l, <math>\mu</math>g/l, %, ‰, ppm, ppb, NTU, FNU, EBC, AU, FAU, S/cm, S/m, mS/m, <math>\mu</math>S/m, mbar, bar, psi, mm, cm, m, inch, ft, mmwc, cmwc, mwc, inwc, ftwc</li> </ul> <p>Modification of the measurement unit will have consequences for other SETUP-level values. Please note that the span has to be adapted as well; the calculation is not done automatically.</p>
12 - Decimals	<p><b>This setting determines the number of digits following the decimal point. The following can be selected:</b></p> <ul style="list-style-type: none"> <li>• 0000</li> <li>• 111.1</li> <li>• 22.22</li> <li>• 3.333</li> </ul>
13 - Offset	<p>The unit needs to know the value at minimum signal, in most applications this is zero (0). For ORP applications however, the offset can be set to -1500.</p> <p><b>The following offset can be programmed:</b></p> <ul style="list-style-type: none"> <li>• - 1500...+3000</li> </ul> <p>To program a negative offset value you have to press the middle and right button simultaneously.</p>
14 - Span	<p>With the span, the sensor signal is converted to a certain value. The span is the measuring range from the offset (value at 4 mA) to the value at 20 mA.</p> <p><b>The following range can be programmed:</b></p> <ul style="list-style-type: none"> <li>• 0.001...+3000</li> </ul>
15 - Filter	<p>Setting the time filter for the measured value. With the help of the digital filter a stable and accurate reading can be obtained while the filter level can be set to a desired value. The higher the filter level, the longer the response time on a value change will be.</p>

Filter value	Response time on step change of analog value Time in seconds				
		50% Influence	75% Influence	90% Influence	95% Influence
01	Filter disabled	Filter disabled	Filter disabled	Filter disabled	Filter disabled
02	0.3	0.5	1.0	1.8	
03	0.5	1.0	1.5	3	
05	1.0	1.8	2.8	5.3	
16 - Calibrate lo - 4mA	<p>With this setting it is possible to re-calibrate the input value for 4 mA but be very sure that the offered signal is correct before the calibration is executed as this function has major influences on the accuracy of the system!</p> <p><b>After pressing PROG, three settings can be selected:</b></p> <ul style="list-style-type: none"> <li>• CALIB (calibrate): with this setting, the input will be calibrated with the actual "4mA" value. After pressing ENTER, TUNED will be displayed as soon as the calibration is completed. From that moment, the value must be more than the calibrated value before the signal will be processed.</li> <li>• DFLT.: with this setting, the factory value is re-installed.</li> <li>• SET: to select the last calibrated value.</li> </ul>				
17 - Calibrate hi - 20mA	<p>With this setting it is possible to re-calibrate the input value for 20 mA but be very sure that the offered signal is correct before the calibration is executed as this function has major influences on the accuracy of the system!</p> <p><b>After pressing PROG, three settings can be selected:</b></p> <ul style="list-style-type: none"> <li>• CALIB (calibrate): with this setting, the input will be calibrated with the actual "20mA" value. After pressing ENTER, "TUNED" will be displayed as soon as the calibration is completed. From that moment, the value must be more than the calibrated value before the signal will be processed.</li> <li>• DFLT.: with this setting, the factory value is re-installed.</li> <li>• SET: to select the last calibrated value.</li> </ul>				

2 - Others (software version 030104)	
21 - Model	Model reflects the model on the I.S. certificate: F400 or D400.
22 - Type	Type reflects the product specific functionality: SD 200 W/R.
23 - Software version	For support and maintenance it is important to have information about the characteristics of the indicator.
24 - Serial number	For support and maintenance it is important to have information about the characteristics of the indicator.
25 - Password	All SETUP-values can be password protected. This protection is disabled with value 0000 (zero). Up to and including 4 digits can be programmed.
26 - Tag number	For identification of the unit and communication purposes, a unique tag number of maximum 7 digits can be entered.

2 - Others (software version 030105...030xxx)	
21 - Model	Model reflects the model on the I.S. certificate: SD 200 W/R.
22 - Software version	For support and maintenance it is important to have information about the characteristics of the indicator.
23 - Serial number	For support and maintenance it is important to have information about the characteristics of the indicator.
24 - Password	All SETUP-values can be password protected. This protection is disabled with value 0000 (zero). Up to and including 4 digits can be programmed.
25 - Tag number	For identification of the unit and communication purposes, a unique tag number of maximum 7 digits can be entered.

## 5.1 Maintenance

The SD 200 W/R devices do not require special maintenance unless it is used in low-temperature applications or surroundings with high humidity (above 90% annual mean). It is the users responsibility to take all precautions to dehumidify the internal atmosphere of the devices in such a way that no condensation will occur, for example by placing dry silica-gel sachet in the casing just before closing it. Furthermore, it is required to replace or dry the silica gel periodically as advised by the silica gel supplier.

The manufacturer recommends the following maintenance measures:

- Check the housing, connector and the feed lines for corrosion and/or damage.
- Check the entire device for dust deposits.
- Check the input/output wiring for reliability and aging symptoms.
- Check the process accuracy.
- Clean the casing with soapy-water. Do not use any aggressive solvents as these might damage the coating.



**CAUTION!**

*Maintenance measures of a safety-relevant nature within the meaning of explosion protection may only be carried out by the manufacturer, his authorised representative or under the supervision of authorised inspectors.*

## 5.2 Availability of services

The manufacturer offers a range of services to support the customer after expiration of the warranty. These include repair, maintenance, technical support and training.



**INFORMATION!**

*For more precise information, please contact your local sales office.*



## 5.3 Returning the device to the manufacturer

### 5.3.1 General information

This device has been carefully manufactured and tested. If installed and operated in accordance with these operating instructions, it will rarely present any problems.



**WARNING!**

*Should you nevertheless need to return a device for inspection or repair, please pay strict attention to the following points:*

- *Due to statutory regulations on environmental protection and safeguarding the health and safety of the personnel, the manufacturer may only handle, test and repair returned devices that have been in contact with products without risk to personnel and environment.*
- *This means that the manufacturer can only service this device if it is accompanied by the following certificate (see next section) confirming that the device is safe to handle.*



**WARNING!**

*If the device has been operated with toxic, caustic, radioactive, flammable or water-endangering products, you are kindly requested:*

- *to check and ensure, if necessary by rinsing or neutralising, that all cavities are free from such dangerous substances,*
- *to enclose a certificate with the device confirming that it is safe to handle and stating the product used.*

### 5.3.2 Form (for copying) to accompany a returned device



**CAUTION!**

*To avoid any risk for our service personnel, this form has to be accessible from outside of the packaging with the returned device.*

Company:		Address:	
Department:		Name:	
Telephone number:		Email address:	
Fax number:			
Manufacturer order number or serial number:			
The device has been operated with the following medium:			
This medium is:	<input type="checkbox"/>	radioactive	
	<input type="checkbox"/>	water-hazardous	
	<input type="checkbox"/>	toxic	
	<input type="checkbox"/>	caustic	
	<input type="checkbox"/>	flammable	
	<input type="checkbox"/>	We checked that all cavities in the device are free from such substances.	
	<input type="checkbox"/>	We have flushed out and neutralized all cavities in the device.	
We hereby confirm that there is no risk to persons or the environment caused by any residual media contained in this device when it is returned.			
Date:		Signature:	
Stamp:			

### 5.4 Disposal



**LEGAL NOTICE!**

*Disposal must be carried out in accordance with legislation applicable in your country.*

**Separate collection of WEEE (Waste Electrical and Electronic Equipment) in the European Union:**



According to the directive 2012/19/EU, the monitoring and control instruments marked with the WEEE symbol and reaching their end-of-life **must not be disposed of with other waste.**

The user must dispose of the WEEE to a designated collection point for the recycling of WEEE or send them back to our local organisation or authorised representative.

## 6.1 Technical data



### INFORMATION!

- The following data is provided for general applications. If you require data that is more relevant to your specific application, please contact us or your local sales office.
- Additional information (certificates, special tools, software,...) and complete product documentation can be downloaded free of charge from the website (Downloadcenter).

### Design

Type	High intensity reflective numeric and alphanumeric LCD, UV-resistant.	
Digits	4 digits 26 mm / 1" and 11 digits with 8 mm / 0.31". Various symbols and measuring units.	
Refresh rate	1 times/sec.	
Wall mount	GRP (Glass fibre Reinforced Polyamide) with polycarbonate window, silicone gaskets. UV stabilised and flame retardant materials.	
	Keypad	Three industrial micro-switch keys. UV-resistant silicone keypad.
	Dimensions LxHxD	130 x 120 x 75 mm / 5.10" x 4.72" x 2.95"
	Classification	IP67 / NEMA4X
	Cable gland	M16
Rack mount	Die-cast aluminium housing with polycarbonate window, silicone gaskets. UV stabilised and flame retardant materials.	
	Keypad	Three industrial micro-switch keys. UV-resistant silicone keypad.
	Dimensions LxHxD	144 x 72 x 46 mm / 5.67" x 2.83" x 1.81"
	Classification	IP65 / NEMA4
	Panel cut-out	138 x 68 mm / 5.43" x 2.68"
	Painting	UV-resistant 2-component industrial painting

### Operating temperature

Operational	-30°C...+80°C / -22°F...+176°F
Intrinsically Safe	-30°C...+70°C / -22°F...+158°F

### Power requirements

Type	Input loop powered from 4-20mA signal input. Voltage drop max. 2V DC.
Note I.S. application	For intrinsically safe applications, consult the safety values in the certificate.

### Terminal connections

Type	Removable plug-in terminal strips. Wire max. 1.5mm <sup>2</sup> / 16 AWG.
------	---

### Data protection

Type	Data backup of all setting. Data retention at least 10 years.
Password	Configuration settings can be password protected.

**Inputs**

Type A	4...20 mA with signal calibration feature.
Accuracy	Resolution: 14 bit Error ≤ 0.1% FS
Span	0.001...3000 units with variables decimal position.
Offset	-1500...3000
Update time	4 times a second
Voltage drop	max. 2 Volt

**Operational**

Operator functions	Displayed functions	Top line: main display value Bottom line: measuring unit and messages
Main display value	Digits	4 digits (height: 26 mm / 1")
	Units	Analysis-unit-package - pH, mV, mS/cm, μS/cm, kΩ*cm, MΩ*cm Multiparameter-unit-package - pH, mV, mS/cm, μS/cm, kΩ*cm, MΩ*cm, °C, °F, °K, g/l, mg/l, μg/l, %, ‰, ppm, ppb, NTU, FNU, EBC, AU, FAU, S/cm, S/m, mS/m, μS/m, mbar, bar, psi, mm, cm, m, inch, ft, mmwc, cmwc, mwc, inwc, ftwc
	Decimals	0 - 1 - 2 - 3

**Approvals and certificates**

CE	
This device fulfils the statutory requirements of the EC directives. The manufacturer certifies successful testing of the product by applying the CE mark.	
For full information of the EU directives and standards and the approved certifications, please refer to the EU declaration or the website of the manufacturer.	
Electromagnetic compatibility:	EMC Directive 2014/30/EU
<b>Hazardous areas</b>	
ATEX approval:	II 1 G Ex ia IIC T4 Ga II 1 D Ex ia IIIC T 100°C Da
IECEx approval:	Ex ia IIC T4 Ga Ex ia IIIC T 100°C Da
CSA approval:	Class I, II, III, Division 1, Groups A to G Ex ia IIC Class I, Zone 0 AEx ia IIC T4

## 6.2 Dimensions

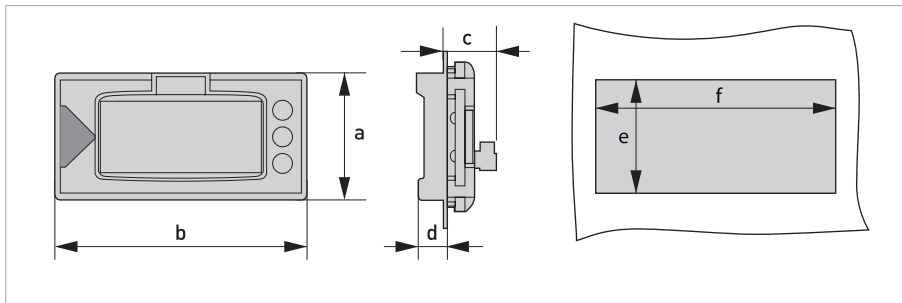

Figure 6-1: Dimensions SD 200 R

	Dimensions [mm]	Dimensions [inch]
a	72	2.83
b	144	5.67
c	30	1.18
d	16	0.63
e	68	2.68
f	138	5.43

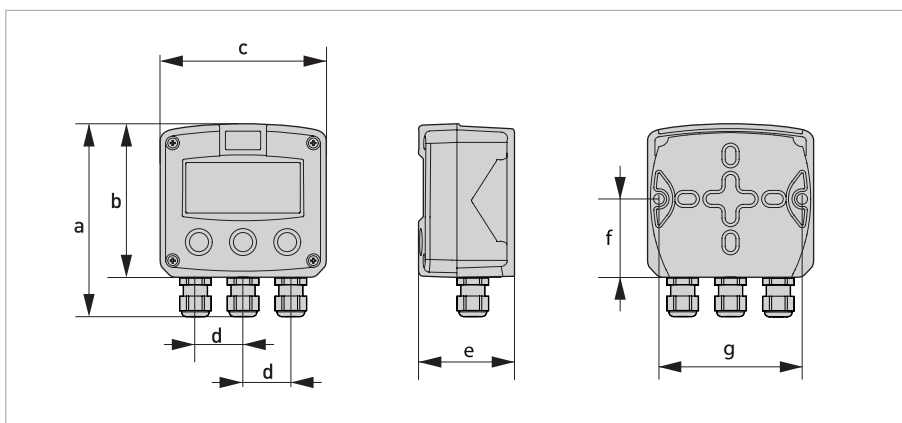

Figure 6-2: Dimensions SD 200 W

	Dimensions [mm]	Dimensions [inch]
a	145	5.71
b	120	4.72
c	130	5.12
d	30	1.18
e	75	2.95
f	60	2.36
g	112	4.41







## KROHNE – Process instrumentation and measurement solutions

- Flow
- Level
- Temperature
- Pressure
- Process Analysis
- Services

Head Office KROHNE Messtechnik GmbH  
Ludwig-Krohne-Str. 5  
47058 Duisburg (Germany)  
Tel.: +49 203 301 0  
Fax: +49 203 301 10389  
info@krohne.com

The current list of all KROHNE contacts and addresses can be found at:  
[www.krohne.com](http://www.krohne.com)

**KROHNE**