



SMARTPAT COND 5200 Handbook

Digital conductive conductivity sensor for chemical and industrial wastewater industry

Electronic Revision:
ER 1.0.0_
(SW.REV 1.0.x)

All rights reserved. It is prohibited to reproduce this documentation, or any part thereof, without the prior written authorisation of KROHNE Messtechnik GmbH.

Subject to change without notice.

Copyright 2019 by
KROHNE Messtechnik GmbH - Ludwig-Krohne-Str. 5 - 47058 Duisburg (Germany)

1	Safety instructions	5
1.1	Intended use	5
1.2	Certifications	5
1.3	Safety instructions from the manufacturer	6
1.3.1	Copyright and data protection	6
1.3.2	Disclaimer	6
1.3.3	Product liability and warranty	7
1.3.4	Information concerning the documentation	7
1.3.5	Warnings and symbols used	8
1.4	Safety instructions for the operator	8
2	Device description	9
2.1	Scope of delivery	9
2.2	Device description	10
2.3	Nameplate	11
3	Installation	12
3.1	General notes on installation	12
3.2	Storage and transport	12
3.3	Pre-installation requirements	13
3.4	Installation procedure	14
3.5	Installing the sensor	14
3.5.1	General installation instructions	14
3.5.2	Installation recommendation	15
4	Electrical connections	17
4.1	Safety instructions	17
4.2	Power supply	17
4.3	Grounding and equipotential bonding	18
4.4	Connecting the cable to the sensor	18
4.5	Connecting the sensor cable	18
4.6	Connection diagram	19
5	Operation	21
5.1	Configuration	21
5.2	Calibration	21
5.2.1	Calibration with PACTware™	22
5.2.2	Calibration with HART® Handheld 475 FIELD COMMUNICATOR	24
5.3	Troubleshooting	26
5.4	Status messages and diagnostic information	27

6 Service	28
<hr/>	
6.1 Maintenance	28
6.1.1 Cleaning	28
6.2 Availability of services	28
6.3 Returning the device to the manufacturer	28
6.3.1 General information	28
6.3.2 Form (for copying) to accompany a returned device	29
6.4 Disposal	29
7 Technical data	30
<hr/>	
7.1 Measuring principle	30
7.1.1 Conductivity measurement	30
7.2 Technical data	31
7.3 Dimensions	33
8 Description of HART interface	35
<hr/>	
8.1 General description	35
8.2 Software history	35
8.3 Connection variants	36
8.3.1 Point-to-Point connection - analogue / digital mode	37
8.4 Inputs/outputs and HART [®] dynamic variables and device variables	38
8.5 Field Communicator 475 (FC 475)	38
8.5.1 Installation	38
8.6 Field Device Tool / Device Type Manager (FDT/DTM)	39
8.6.1 Installation	39
8.7 Overview Basic-DD menu tree (for Field Communicator 475)	39
8.8 Basic-DD menu tree (details for settings)	40
9 Notes	43
<hr/>	

1.1 Intended use

**DANGER!**

For devices used in hazardous areas, additional safety notes apply; please refer to the Ex documentation.

**CAUTION!**

Responsibility for the use of the measuring devices with regard to suitability, intended use and corrosion resistance of the used materials against the measured fluid lies solely with the operator.

**INFORMATION!**

This device is a Group 1, Class A device as specified within CISPR11:2009. It is intended for use in industrial environment. There may be potential difficulties in ensuring electromagnetic compatibility in other environments, due to conducted as well as radiated disturbances.

**INFORMATION!**

The manufacturer is not liable for any damage resulting from improper use or use for other than the intended purpose.

The intended use of the sensor SMARTPAT COND 5200 is the measurement of conductivity in conductive liquids.

1.2 Certifications

CE marking



The device meets the essential requirements of the EU directives. The CE marking indicates the conformity of the product with the union legislation applying to the product and providing for CE marking.

For full information of the EU directives and standards and the approved certifications, please refer to the EU declaration on the KROHNE website.

Other approvals and standard

- NAMUR recommendation NE 21

The manufacturer certifies successful testing of the product by applying the CE marking.

1.3 Safety instructions from the manufacturer

1.3.1 Copyright and data protection

The contents of this document have been created with great care. Nevertheless, we provide no guarantee that the contents are correct, complete or up-to-date.

The contents and works in this document are subject to copyright. Contributions from third parties are identified as such. Reproduction, processing, dissemination and any type of use beyond what is permitted under copyright requires written authorisation from the respective author and/or the manufacturer.

The manufacturer tries always to observe the copyrights of others, and to draw on works created in-house or works in the public domain.

The collection of personal data (such as names, street addresses or e-mail addresses) in the manufacturer's documents is always on a voluntary basis whenever possible. Whenever feasible, it is always possible to make use of the offerings and services without providing any personal data.

We draw your attention to the fact that data transmission over the Internet (e.g. when communicating by e-mail) may involve gaps in security. It is not possible to protect such data completely against access by third parties.

We hereby expressly prohibit the use of the contact data published as part of our duty to publish an imprint for the purpose of sending us any advertising or informational materials that we have not expressly requested.

1.3.2 Disclaimer

The manufacturer will not be liable for any damage of any kind by using its product, including, but not limited to direct, indirect or incidental and consequential damages.

This disclaimer does not apply in case the manufacturer has acted on purpose or with gross negligence. In the event any applicable law does not allow such limitations on implied warranties or the exclusion of limitation of certain damages, you may, if such law applies to you, not be subject to some or all of the above disclaimer, exclusions or limitations.

Any product purchased from the manufacturer is warranted in accordance with the relevant product documentation and our Terms and Conditions of Sale.

The manufacturer reserves the right to alter the content of its documents, including this disclaimer in any way, at any time, for any reason, without prior notification, and will not be liable in any way for possible consequences of such changes.

1.3.3 Product liability and warranty

The operator shall bear responsibility for the suitability of the device for the specific purpose. The manufacturer accepts no liability for the consequences of misuse by the operator. Improper installation or operation of the devices (systems) will cause the warranty to be void. The respective "Standard Terms and Conditions" which form the basis for the sales contract shall also apply.

1.3.4 Information concerning the documentation

To prevent any injury to the user or damage to the device it is essential that you read the information in this document and observe applicable national standards, safety requirements and accident prevention regulations.

If this document is not in your native language and if you have any problems understanding the text, we advise you to contact your local office for assistance. The manufacturer can not accept responsibility for any damage or injury caused by misunderstanding of the information in this document.

This document is provided to help you establish operating conditions, which will permit safe and efficient use of this device. Special considerations and precautions are also described in the document, which appear in the form of icons as shown below.

1.3.5 Warnings and symbols used

Safety warnings are indicated by the following symbols.



DANGER!

This warning refers to the immediate danger when working with electricity.



DANGER!

This warning refers to the immediate danger of burns caused by heat or hot surfaces.



DANGER!

This warning refers to the immediate danger when using this device in a hazardous atmosphere.



DANGER!

These warnings must be observed without fail. Even partial disregard of this warning can lead to serious health problems and even death. There is also the risk of seriously damaging the device or parts of the operator's plant.



WARNING!

Disregarding this safety warning, even if only in part, poses the risk of serious health problems. There is also the risk of damaging the device or parts of the operator's plant.



CAUTION!

Disregarding these instructions can result in damage to the device or to parts of the operator's plant.



INFORMATION!

These instructions contain important information for the handling of the device.



LEGAL NOTICE!

This note contains information on statutory directives and standards.



• **HANDLING**

This symbol designates all instructions for actions to be carried out by the operator in the specified sequence.

➔ **RESULT**

This symbol refers to all important consequences of the previous actions.

1.4 Safety instructions for the operator



WARNING!

In general, devices from the manufacturer may only be installed, commissioned, operated and maintained by properly trained and authorized personnel.

This document is provided to help you establish operating conditions, which will permit safe and efficient use of this device.

2.1 Scope of delivery

**INFORMATION!**

Inspect the packaging carefully for damages or signs of rough handling. Report damage to the carrier and to the local office of the manufacturer.

**INFORMATION!**

Do a check of the packing list to make sure that you have all the elements given in the order.

**INFORMATION!**

Look at the device nameplate to ensure that the device is delivered according to your order.

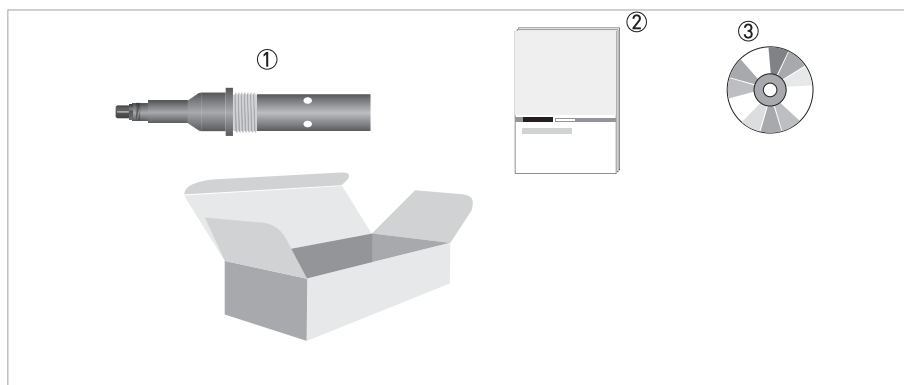

Figure 2-1: Standard scope of delivery

- ① Ordered sensor with the ordered process connection
- ② Documentation, including calibration certificate
- ③ CD with sensor software

Optional accessories

- SENSOFIT IMM 2000 series - Immersion assemblies (for G 3/4 sensor versions)
- Cable VP2-S (cable with shield in various lengths)
- SD 200 W/R – Wall or rack mount indicator
- OPTIBRIDGE – USB interface cable
- SJB 200 W-Ex – Junction box

Consumables/Spare parts available

- Various conductivity standard solutions for sensor calibration

**INFORMATION!**

For further information contact your local sales office.

2.2 Device description

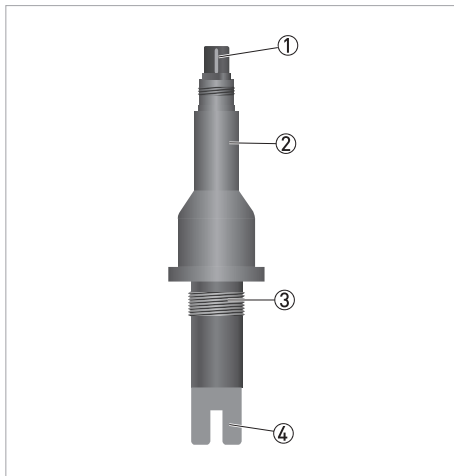

Figure 2-2: Construction of the sensor

- ① VP2 connector
- ② PEEK body
- ③ Process connection: G3/4 A thread (male) or 3/4-14 NPT (male), PVDF
- ④ Electrodes: graphite, PES

2.3 Nameplate



Figure 2-3: Example for a nameplate on the sensor body

- ① Manufacturer
- ② Device name
- ③ Cell constant / Electronic Revision version
- ④ TAG number (optional)
- ⑤ Order code
- ⑥ Serial number
- ⑦ Manufacturing date / Ingress protection
- ⑧ Electronic - Electric device waste marking /
Observe the operation and installation instruction / Approvals



INFORMATION!

Look at the device nameplate to ensure that the device is delivered according to your order.

The sensor type is specified on the label of the sensor package and on the sensor itself.

3.1 General notes on installation

**DANGER!**

For devices used in hazardous areas, additional safety notes apply; please refer to the Ex documentation.

**DANGER!**

All work on the electrical connections may only be carried out with the power disconnected.

**DANGER!**

Observe the national regulations for electrical installations!

**WARNING!**

During installation of the device make sure that you use ESD (electrostatic discharge) protection equipment.

**WARNING!**

Observe without fail the local occupational health and safety regulations. Any work done on the electrical components of the measuring device may only be carried out by properly trained specialists.

**INFORMATION!**

Inspect the packaging carefully for damages or signs of rough handling. Report damage to the carrier and to the local office of the manufacturer.

**INFORMATION!**

Do a check of the packing list to make sure that you have all the elements given in the order.

**INFORMATION!**

Look at the device nameplate to ensure that the device is delivered according to your order.

3.2 Storage and transport

**CAUTION!**

Do not make any mechanical modifications to the sensor (electrodes shortened, drilled, bent or scratched). This can result in the loss of proper functionality, as well as the rights under the device warranty.

- *Store and transport the device in a dry, dust-free environment.*
- *Store and transport the device in an environment with a temperature between -40...+85° C / -40...+185° F.*
- *The original packing is designed to protect the equipment. It has to be used if the device is transported or sent back to the manufacturer including the sensor transportation packing, to prevent damage of the sensor.*

3.3 Pre-installation requirements



CAUTION!

- Do not drop the device! Handle the device with care!
- Never touch or scratch the electrodes of the sensor.
- Store the sensor in its original packaging in a dry, dust-free location. Keep it away from dirt. If necessary, clean it. See cleaning procedure on page 28.
- Do not make any mechanical modifications to the sensor (electrodes shortened, drilled, bent or scratched). This can result in the loss of proper functionality, as well as the rights under the device warranty.
- The sensor must be suitable for the temperature, pressure and medium conditions which are specified (including chemical resistance).
- The device must not be heated by radiated heat (e.g. exposure to the sun) to a electronics housing surface temperature above the maximum permissible ambient temperature. If it is necessary to prevent damage from heat sources, a heat protection (e.g. sun shade) has to be installed.



INFORMATION!

A sensor specific DTM software for usage with PACTware™ FDT is available. The DTM software is free of charge and available from CD (scope of delivery) or can be downloaded from the KROHNE website (Downloadcenter).

The required steps are explained in the following sections.

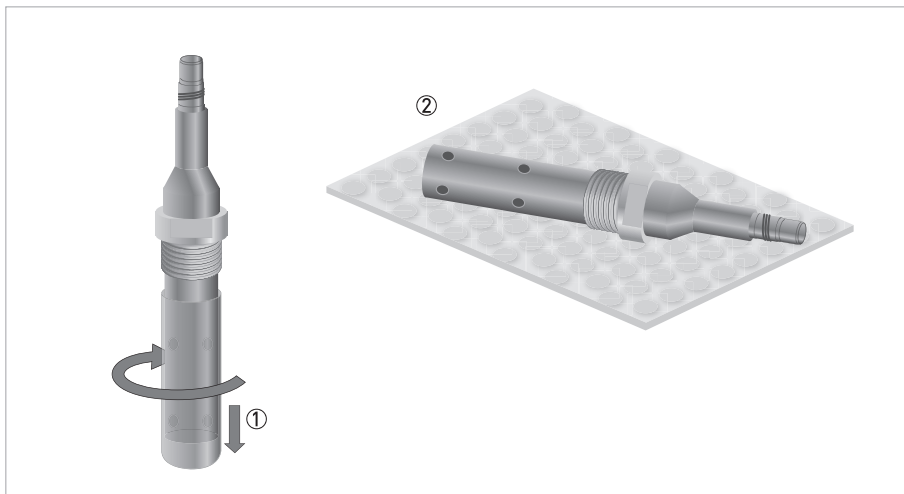

Figure 3-1: Unpacking the sensor



Unpacking the sensor

- Remove by gently twisting and pulling the protective cap from the sensor ①.
- Lay the sensor on a soft ESD mat or soft paper tissue ②.
- Leave the protection cap of the VP connector in place, as long as the sensor is not connected to the cable.

3.4 Installation procedure



WARNING!

During installation of the device make sure that you use ESD (electrostatic discharge) protection equipment.



WARNING!

Check the inner diameter of the process connection at the final measuring location before installing the sensor. For sensors with 3/4" thread, a minimum diameter of 24.5 mm / 0.96" is required. Otherwise the sensor cannot be installed or might be damaged.

Recommendation:

make the thread at the final measuring location acc. to standard and wide up lower end to 24.5 mm (lower end thread part is not needed for proper and water-tight installation).

Never try to install a sensor in a fitting with less than 24.5 mm inner diameter.



- ① Connect the sensor to the junction box or directly to the process control system.
- ② Install the sensor into its final measuring location.
- ③ If necessary re-calibrate the cell constant for your process conditions. (For further information refer to *Calibration* on page 21.)

3.5 Installing the sensor

3.5.1 General installation instructions



WARNING!

Ensure that the pipeline is without pressure before installing or removing a sensor!



INFORMATION!

During installation you should fix a shut-off valve in front of and behind the instrument so that the sensor can be taken out in case of check.



INFORMATION!

For open basin installations using immersion assemblies (e.g. SENSOFIT IMM 2000), please refer to the appropriate user manual.



INFORMATION!

To achieve reliable measuring results, the electrodes must always have full contact with the measuring medium.



INFORMATION!

Basically any installation position is possible. However, ensure that sufficient medium flows through and around the electrodes (the conductive electrodes must always be completely surrounded by the medium). Structural measures must be taken to prevent flow interruption or gas bubbles.

3.5.2 Installation recommendation

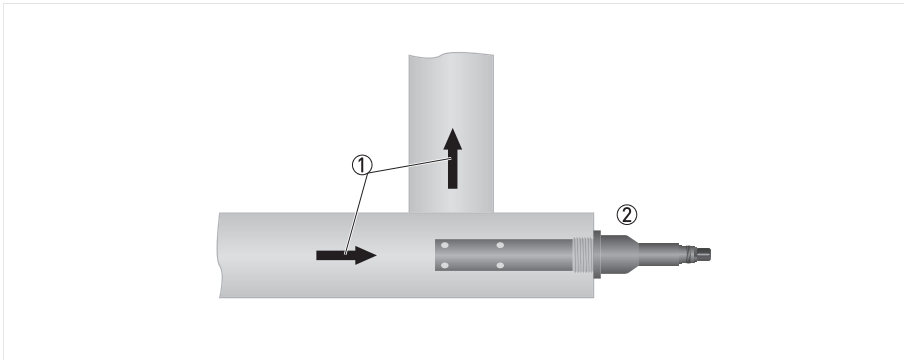

Figure 3-2: Typical installation

- ① Flow direction
- ② Ordered sensor

- Installation against the flow to ensure direct exposure of the electrodes.

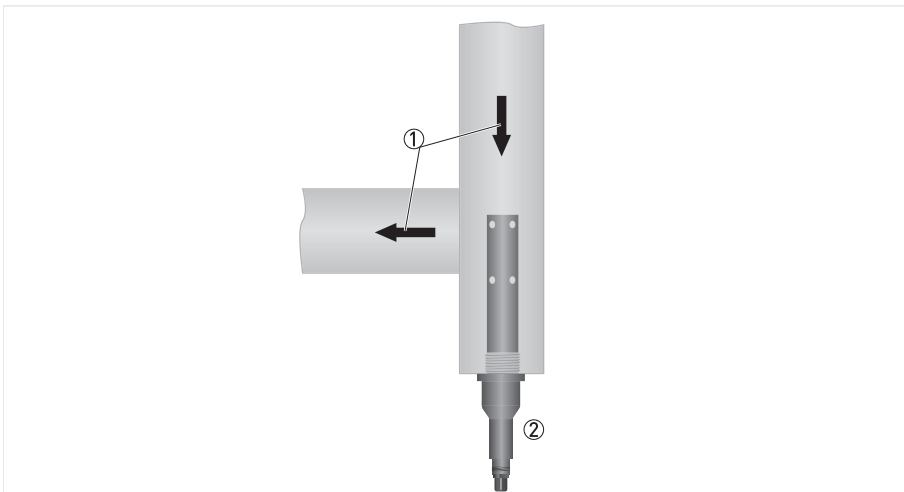

Figure 3-3: Installation for clean water

- ① Flow direction
- ② Ordered sensor

- This installation is only recommended if the pipeline is completely filled and if there are no particles or air bubbles in the pipeline.

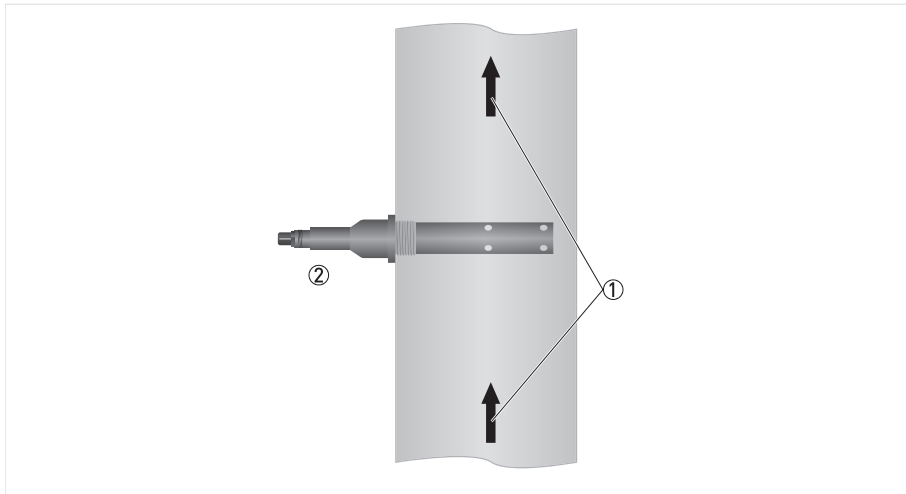

Figure 3-4: Possible installation

- ① Flow direction
- ② Ordered sensor

- This installation is only recommended if the pipeline is completely filled and if there are no particles or air bubbles in the pipeline.
- Consider the diameter of the pipeline, i.e. compare pipeline DN with insertion length of the sensor shaft.

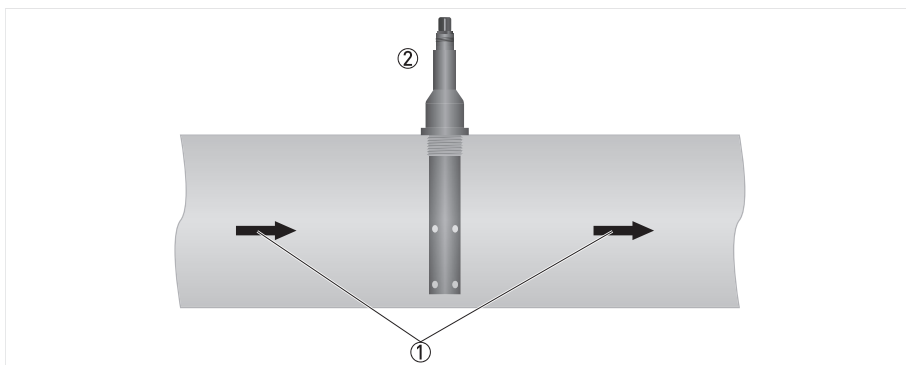

Figure 3-5: Possible installation

- ① Flow direction
- ② Ordered sensor

- This installation is only recommended if the pipeline is completely filled and if there are no particles or air bubbles in the pipeline.
- Consider the diameter of the pipeline, i.e. compare pipeline DN with insertion length of the sensor shaft.

4.1 Safety instructions



DANGER!

For devices used in hazardous areas, additional safety notes apply; please refer to the Ex documentation.



DANGER!

All work on the electrical connections may only be carried out with the power disconnected.



DANGER!

Observe the national regulations for electrical installations!



WARNING!

Observe without fail the local occupational health and safety regulations.

Any work done on the electrical components of the measuring device may only be carried out by properly trained specialists.



INFORMATION!

Look at the device nameplate to ensure that the device is delivered according to your order.

4.2 Power supply



CAUTION!

Do not use the integrated 250 Ohm HART[®] resistor, e.g. of SJB 200 W or SMARTMAC 200 W etc., when using an Ex isolation amplifier of third-party with integrated 250 Ohm HART[®] resistor.

The sensor requires a minimum operating voltage of 15 VDC. The power supply is provided via the 2-wire interface (4...20 mA).

During initialisation of the sensor following values appear in the display mode of the "Measuring value":

Conductivity	NaN
Resistance	NaN
Temperature	NaN
Loop current	NaN

The specification NaN (Not a Number) disappears after a few seconds once the initialisation of the sensor is completed. Afterwards, the measured values appear.

4.3 Grounding and equipotential bonding

Sensor type SMARTPAT COND 5200 must be grounded (hard grounding or capacitive connection to ground).

SJB 200 W-Ex junction box offers the grounding possibility.
For further information refer to the SJB 200 W-Ex manual.

For SMARTPAT sensor connection only use a VarioPin cable with shield wire, like the cable VP2-S.

4.4 Connecting the cable to the sensor



WARNING!

During installation of the device make sure that you use ESD (electrostatic discharge) protection equipment.



CAUTION!

Moisture on the sensor connector must be avoided! Moisture may cause a short-circuit and a malfunction of the sensor!

If moisture has entered the connector dry it with air (e.g. hair blower).

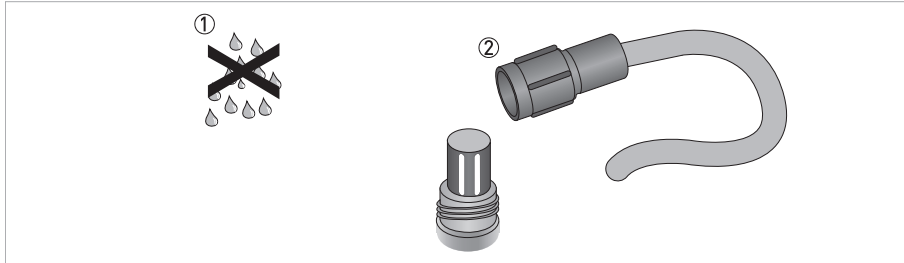

Figure 4-1: Connecting the cable to the sensor



Connecting the cable to the sensor

- Ensure that both cable and sensor connector are absolutely dry ①.
- Screw the cable connector ② on the sensor connector and tighten it by hand.

4.5 Connecting the sensor cable



DANGER!

All work on the electrical connections may only be carried out with the power disconnected.

Cable VP2-S

Transparent-black (inner coax shield)	A
White	B
Shield	S

4.6 Connection diagram



INFORMATION!

The connection diagram for junction box SJB 200 W-Ex is shown as an example. Please refer to the user manuals of other devices for correct connection of SMARTPAT 2-wire sensors, e.g. SMARTMAC operating units or SD 200 displays.

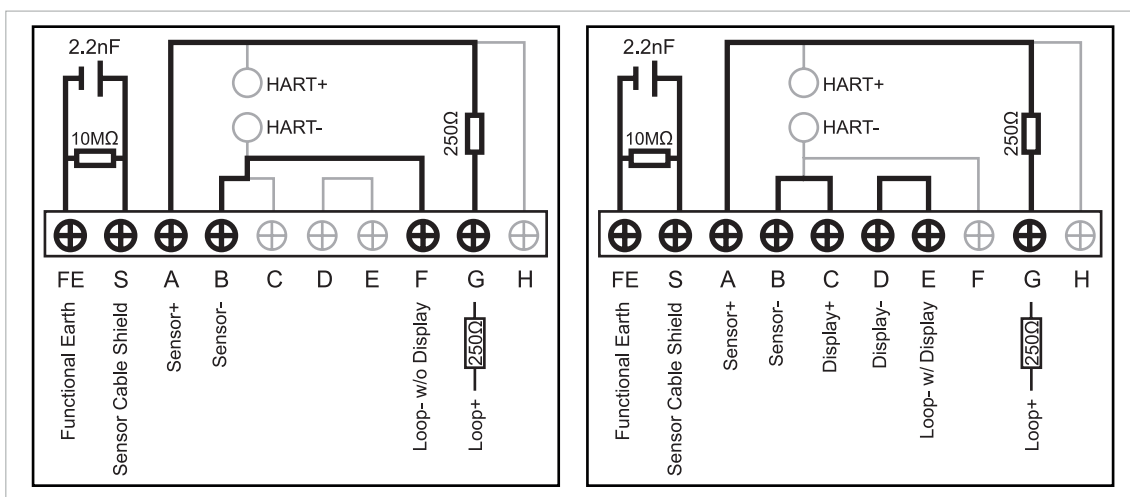

Figure 4-2: SJB 200 W-Ex with SMARTPAT sensor, integrated HART[®] resistor and without display (left side). SJB 200 W-Ex with SMARTPAT sensor, integrated HART[®] resistor and display (right side).

SJB 200 W-Ex with SMARTPAT sensor, integrated HART [®] resistor and without display.		SJB 200 W-Ex with SMARTPAT sensor, integrated HART [®] resistor and display.	
FE	Ground (housing)	FE	Ground (housing)
S	Sensor cable shield	S	Sensor cable shield
A	Sensor+	A	Sensor+
B	Sensor-	B	Sensor-
F	Loop-	C	Display+
G	Loop+ 250Ω	D	Display-
		E	Loop- with Display
		G	Loop+ 250Ω

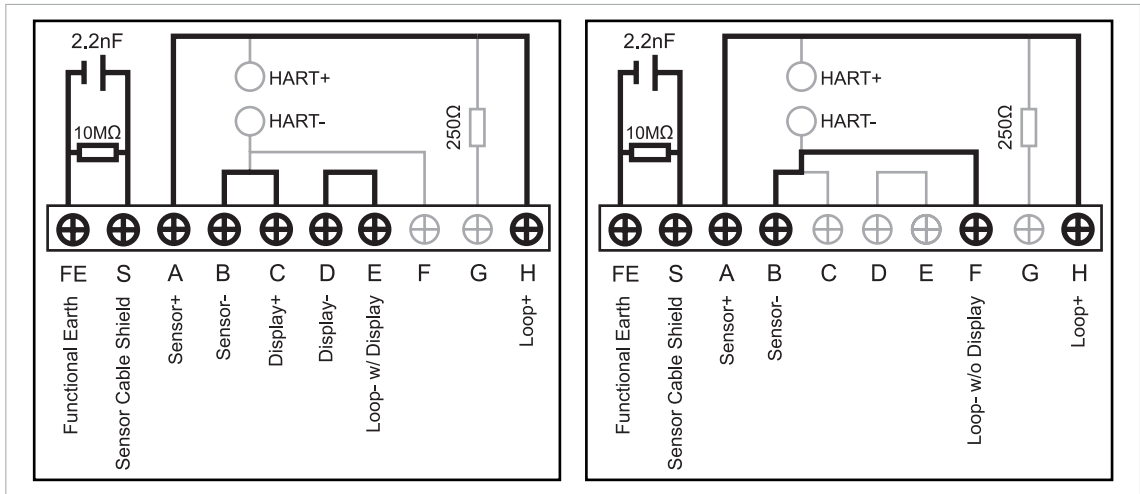

Figure 4-3: SJB 200 W-Ex with SMARTPAT sensor, display and without integrated HART[®] resistor (left side).
 SJB 200 W-Ex with SMARTPAT sensor, without display and integrated HART[®] resistor (right side)

SJB 200 W-Ex with SMARTPAT sensor, display and without integrated HART [®] resistor.		SJB 200 W-Ex with SMARTPAT sensor, without display and integrated HART [®] resistor.	
FE	Ground (housing)	FE	Ground (housing)
S	Sensor cable shield	S	Sensor cable shield
A	Sensor+	A	Sensor+
B	Sensor-	B	Sensor-
C	Display+	F	Loop-
D	Display-	H	Loop+
E	Loop- with Display		
H	Loop+		

5.1 Configuration

For configuration connect the sensor to the loop and configure the sensor via PACTware™ FDT/DTM. Otherwise for offline configuration the sensor can be connected to the OPTIBRIDGE or another suitable USB interface cable. OPTIBRIDGE will be connected to the PC via USB port. Add the devices regarding the instructions of PACTware™.



INFORMATION!

The sensor configuration has to be done in the online configuration dialog of PACTware™ FDT/DTM. If the configuration will be done in the offline configuration dialog of PACTware™, many functions are disabled e.g. calibration. The sensor configuration data will also be overwritten with default settings for e.g. 4...20 mA, TAG, etc.

For more information refer to *Overview Basic-DD menu tree (for Field Communicator 475)* on page 39.

5.2 Calibration



INFORMATION!

Set temperature compensation before calibration. Select between linear, natural water or off. Default setting: linear

For offline calibration via PACTware™ FDT/DTM the sensor can be connected to the OPTIBRIDGE or another suitable USB interface cable. OPTIBRIDGE will be connected to the PC via USB port. Add the devices regarding the instructions of PACTware™.

For more information refer to *Basic-DD menu tree (details for settings)* on page 40.

5.2.1 Calibration with PACTware™



Calibration

- Start the function **calibration** in menu mode **Quick Setup** or **Setup**



Select calibration method

- Choose **Product calibration** to calibrate the sensor with the help of a reference sensor
- Choose **Calibration solution** to calibrate the sensor with the help of a reference solution
- Choose **Input cell constant** to enter the calibrated cell constant of a sensor



Product calibration

- Choose **Product calibration** and press **Next** to proceed
- Activate the function **Manual hold?** to avoid an alarm
- Select **Yes**
- Press **Next** to proceed
- Please wait until the measuring value is stable
- Press **Next** to proceed
- Please wait for approx. 10 seconds and the following values appear:
 - Measuring value
 - Status -> Finished
- Press **Next** to proceed
- Choose the correct unit and press **Next** to proceed
- Set the reference value
- Press **Next** to proceed
- The old cell constant and the calculated new cell constant appear
- If you want to save the new cell constant press **Next** to proceed
- Set the calibration date with DD-MM-YYYY
- Press **Next** to proceed
- The message **Save value?** appears
- Select **Yes** to save the values (Selecting **No** is followed by the same procedure just without saving the values)
- Press **Next** to proceed
- Deactivate the function **Manual hold?** with choosing **No**
- Press **Next** to leave the calibration menu



Calibration solution

- Choose **Calibration solution** and press **Next** to proceed
- Activate the function **Manual hold?** to avoid an alarm
- Select **Yes**
- Press **Next** to proceed
- Set the unit of the calibration solution
- Choose the correct unit and press **Next** to proceed
- Set the value of the calibration solution
- After setting the value press **Next** to proceed
- Please wait until the measuring value is stable
- Press **Next** to proceed
- Please wait for approx. 10 seconds and the following values appear:
 - Measuring value
 - Status -> Finished
- Press **Next** to proceed
- The old cell constant and the calculated new cell constant appear

- If you want to save the new cell constant press **Next** to proceed
- Set the calibration date with DD-MM-YYYY
- Press **Next** to proceed
- ➡ The message **Save value?** appears
- Select **Yes** to save the values (Selecting **No** is followed by the same procedure just without saving the values)
- Press **Next** to proceed
- Deactivate the function **Manual hold?** with choosing **No**
- Press **Next** to leave the calibration menu



Input cell constant

- Choose **Input cell constant** and press the key **Next**
- Activate the function **Manual hold?** to avoid an alarm
- Select **Yes**
- Press **Next** to proceed
- Input the new cell constant
- ➡ To save the new cell constant, press **Next** to proceed
- Set the calibration date with DD-MM-YYYY
- Press **Next** to proceed
- ➡ The message **Save value?** appears
- Select **Yes** to save the values (Selecting **No** is followed by the same procedure just without saving the values)
- Press **Next** to proceed
- Deactivate the function **Manual hold?** with choosing **No**
- Press **Next** to leave the calibration menu



CAUTION!

Moisture on the sensor connector must be avoided! Moisture may cause a short-circuit and a malfunction of the sensor!

If moisture has entered the connector dry it with air (e.g. hair blower).



CAUTION!

Do not make any mechanical modifications to the sensor (electrodes shortened, drilled, bent or scratched).

Make sure that the measuring electrodes are clean and dust-free. If necessary, clean the electrodes as described on page 28.

5.2.2 Calibration with HART® Handheld 475 FIELD COMMUNICATOR



Calibration

- Start the function **calibration** in menu mode **Quick Setup** or **Setup**



Select calibration method

- Choose **Product calibration** to calibrate the sensor with the help of a reference sensor
- Choose **Calibration solution** to calibrate the sensor with the help of a reference solution
- Choose **Input cell constant** to enter the calibrated cell constant of a sensor



Product calibration

- Choose **Product calibration** and press the key **>**
- Activate the function **Manual hold?** to avoid an alarm
- Select **Yes**
- Press **Enter** to proceed
- Please wait until the measuring value is stable
- Press **OK** to proceed
- Please wait for approx. 10 seconds and the following values appear:
 - Measuring value
 - Status -> Finished
- Press **OK** to proceed
- You are asked to save the measured value
- Press **OK** to proceed
- Choose the correct unit and press **Enter** to proceed
- Set the reference value
- After setting the value press **Enter** to proceed
- The old cell constant and the calculated new cell constant appear
- If you want to save the new cell constant press **Ok** to proceed
- Set the calibration date with MM-DD-YYYY
- Press **Enter** to proceed
- The message **Save value?** appears
- Select **Yes** to save the values (Selecting **No** is followed by the same procedure just without saving the values)
- Press **Enter** to proceed
- Deactivate the function **Manual hold?** with choosing **No**
- Press **Enter** to leave the calibration menu



Calibration solution

- Choose **Calibration solution** and press the key **>**
- Activate the function **Manual hold?** to avoid an alarm
- Select **Yes**
- Press **Enter** to proceed
- Choose the correct unit and press **Enter** to proceed
- Set the value of the calibration solution
- After setting the value press **Enter** to proceed
- Please wait until the measuring value is stable
- Press **OK** to proceed
- Please wait for approx. 10 seconds and the following values appear:
 - Measuring value
 - Status -> Finished
- Press **OK** to proceed

- The old cell constant and the calculated new cell constant appear
 - If you want to save the new cell constant press **OK** to proceed
 - Set the calibration date with MM-DD-YYYY
 - Press **Enter** to proceed
- The message **Save value?** appears
 - Select **Yes** to save the values (Selecting **No** is followed by the same procedure just without saving the values)
 - Press **Enter** to proceed
 - Deactivate the function **Manual hold?** with choosing **No**
 - Press **Enter** to leave the calibration menu



Input cell constant

- Choose **Input cell constant** and press the key >
- Activate the function **Manual hold?** to avoid an alarm
- Select **Yes**
- Press **Enter** to proceed
- Input the new cell constant
- Press **Enter** to proceed
- The message **Save new cell constant?** appears and the values for the old and new cell constant are shown
 - Press **OK** to proceed
 - Set the calibration date with MM-DD-YYYY
 - Press **Enter** to proceed
- The message **Save value?** appears
 - Select **Yes** to save the values (Selecting **No** is followed by the same procedure just without saving the values)
 - Press **Enter** to proceed
 - Deactivate the function **Manual hold?** with choosing **No**
 - Press **Enter** to leave the calibration menu



CAUTION!

Moisture on the sensor connector must be avoided! Moisture may cause a short-circuit and a malfunction of the sensor!

If moisture has entered the connector dry it with air (e.g. hair blower).



CAUTION!

- *Do not make any mechanical modifications to the sensor (electrodes shortened, drilled, bent or scratched).*
- *Make sure that the measuring electrodes are clean and dust-free. If necessary, clean the electrodes as described on page 28.*

5.3 Troubleshooting

Problem	Possible cause	Remedy
The conductivity sensor does not deliver a HART® or 4...20 mA signal.	Open circuit or humidity between the connections.	Check the cable wiring of the sensor cable on the junction box. Otherwise connect the sensor to the primary master e.g. PACTware™ FTD/DTM or to the HART® handheld to exclude a sensor damage.
The conductivity sensor delivers an unstable signal. The measurement value is too high or too low.	The measuring electrodes are covered by dirt.	Regular cleaning must therefore be performed, relative to the susceptibility of the medium to contamination! All suitable, common household cleaning chemicals can be used for cleaning. Abrasive cleaners have limited suitability! The measurement electrodes must not be damaged mechanically! Dilute hydrochloric acid, or cleaning in ultrasonic baths, can be helpful to prevent various accumulations, for more information refer to <i>Cleaning</i> on page 28.
	The measuring electrodes are not in full contact with the medium.	The measuring electrodes have to be always in full contact with the medium. Make sure that the electrodes are fully immersed into the medium.
	Temperature fluctuation	Select a suitable temperature compensation.
	Air bubbles in the pipeline	Check the installation position of the sensor. If necessary increase the process pressure. Make sure that the pipeline is completely filled.
No conductivity measurement.	Broken lead, incorrect electrical connection. Electrodes are exposed to air (not fully immersed).	Check the electrical connection again! Check the installation location: is liquid medium present?
No temperature measurement (only applicable via HART®DD or PACTware™ FTD/DTM).	Temperature sensor is faulty.	Exchange conductivity sensor.

5.4 Status messages and diagnostic information

Measurements out of specification

Message	Description DD	Description DTM	Action
S01	Cond. > Max. cond.	Conductivity > Max. conductivity	Consider the measuring range limits, otherwise select a suitable sensor for the process conditions of the application.
	Conductive value out of range		
S02	Cond. < Min. cond.	Conductivity < Min. conductivity	
	Conductive value out of range		
S03	Res. > Max. res.	Resistivity > Max. resistivity	
	Resistivity value out of range		
S04	Res. < Min. res.	Resistivity < Min. resistivity	
	Resistivity value out of range		
S05	T > Temp. Max.	Temperature > Max. temperature	
	Temperature value out of range		
S06	T < Temp. Min.	Temperature < Min. temperature	
	Temperature value out of range		

Maintenance

Message	Description DD	Description DTM	Description DTM
M01	Data out of range	Calibration data out of range	Recalibrate the sensor. For more information refer to <i>Calibration with HART® Handheld 475 FIELD COMMUNICATOR</i> on page 24 or refer to <i>Calibration with PACTware™</i> on page 22.
	Failure in calibration; cell constant deviation		
M02	Maint. interval	Maintenance interval expired	
	Maintenance interval expired		

6.1 Maintenance

6.1.1 Cleaning

The conductive conductivity electrodes are in direct contact with the medium. Regular cleaning must therefore be performed, relative to the susceptibility of the medium to contamination! All suitable, common household cleaning chemicals can be used for cleaning. Abrasive cleaners have limited suitability!

The measurement electrodes must not be damaged mechanically!

Diluted hydrochloric acid, or cleaning in ultrasonic baths, can be helpful to prevent various accumulations.

6.2 Availability of services

The manufacturer offers a range of services to support the customer after expiration of the warranty. These include repair, maintenance, technical support and training.



INFORMATION!

For more precise information, please contact your local sales office.

6.3 Returning the device to the manufacturer

6.3.1 General information

This device has been carefully manufactured and tested. If installed and operated in accordance with these operating instructions, it will rarely present any problems.



WARNING!

Should you nevertheless need to return a device for inspection or repair, please pay strict attention to the following points:

- *Due to statutory regulations on environmental protection and safeguarding the health and safety of the personnel, the manufacturer may only handle, test and repair returned devices that have been in contact with products without risk to personnel and environment.*
- *This means that the manufacturer can only service this device if it is accompanied by the following certificate (see next section) confirming that the device is safe to handle.*



WARNING!

If the device has been operated with toxic, caustic, radioactive, flammable or water-endangering products, you are kindly requested:

- *to check and ensure, if necessary by rinsing or neutralising, that all cavities are free from such dangerous substances,*
- *to enclose a certificate with the device confirming that it is safe to handle and stating the product used.*

6.3.2 Form (for copying) to accompany a returned device



CAUTION!

To avoid any risk for our service personnel, this form has to be accessible from outside of the packaging with the returned device.

Company:		Address:	
Department:		Name:	
Tel. no.:		Fax no. and/or Email address:	
Manufacturer's order no. or serial no.:			
The device has been operated with the following medium:			
This medium is:	<input type="checkbox"/>	radioactive	
	<input type="checkbox"/>	water-hazardous	
	<input type="checkbox"/>	toxic	
	<input type="checkbox"/>	caustic	
	<input type="checkbox"/>	flammable	
	<input type="checkbox"/>	We checked that all cavities in the device are free from such substances.	
<input type="checkbox"/>	We have flushed out and neutralized all cavities in the device.		
We hereby confirm that there is no risk to persons or the environment through any residual media contained in the device when it is returned.			
Date:		Signature:	
Stamp:			

6.4 Disposal



LEGAL NOTICE!

Disposal must be carried out in accordance with legislation applicable in your country.

Separate collection of WEEE (Waste Electrical and Electronic Equipment) in the European Union:



According to the directive 2012/19/EU, the monitoring and control instruments marked with the WEEE symbol and reaching their end-of-life **must not be disposed of with other waste**.

The user must dispose of the WEEE to a designated collection point for the recycling of WEEE or send them back to our local organisation or authorised representative.

7.1 Measuring principle

7.1.1 Conductivity measurement

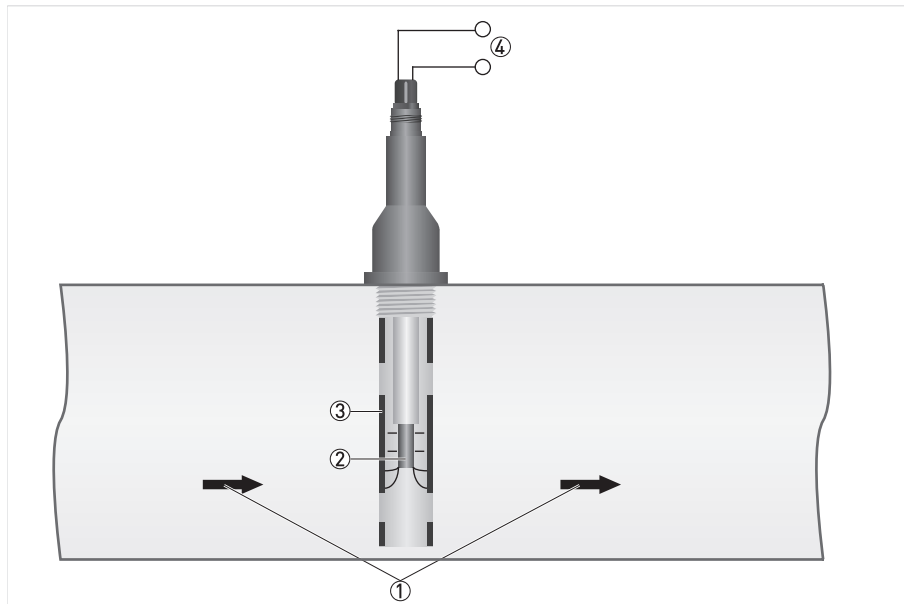

Figure 7-1: Measuring principle for conductivity measurement

- ① Flow direction
- ② Inner electrode
- ③ Outer electrode
- ④ Power supply

The principle of conductivity measurement is defined as the capacity of a solution to conduct an electrical current between two electrodes. In a solution, the current flows by ion transport. The higher the ion concentration, the more current can flow. Using Ohm's law: Resistance = Voltage/Current, the resistance of a liquid can be determined by measuring the current while keeping the voltage constant. Specific conductivity is defined by 1/resistivity. The unit of measurement is Siemens/meter and is normally expressed in $\mu\text{S}/\text{cm}$.

An important criterion for the measuring range of conductivity cells is the geometry of the electrodes. There are two rules which are characteristic for conductivity measurement:

1. The larger the distance between the two electrodes, the larger the resistance.
2. The larger the electrode surface, the lower the resistance.

The surface area (A) and the distance (L) must be correctly matched to the desired measuring range. This is called the "cell constant" defined as $c=L/A$.

7.2 Technical data



INFORMATION!

- The following data is provided for general applications. If you require data that is more relevant to your specific application, please contact us or your local sales office.
- Additional information (certificates, special tools, software,...) and complete product documentation can be downloaded free of charge from the website (Downloadcenter).

Measuring system

Measuring principle	Conductivity measurement - conductive
Measuring range	10 µS/cm...15 mS/cm (c=1) at 25°C / 77°F

Design

Temperature sensor	Pt1000
Connector	VarioPin 2.0 (VP2)

Operating conditions

Process temperature	0...+130°C / +32...+266°F
Ambient temperature	-10...+85°C / +14...+185°F
Storage temperature	-40...+85°C / -40...+185°F
Process pressure	16 bar at 25°C / 232 psi at 77°F, 9 bar at 60°C / 130.5 psi at 140°F
Measuring accuracy	±3% of the measured value

Installation conditions

Ingress protection	IP68
Weight	Approx. 153 g / 0.34 lb
Process connection	G3/4 A thread (male) or 3/4-14 NPT (male) ①

Materials

Process connection	PVDF
Electrodes	Graphite, PES
Sensor head	PEEK body with VP2 connector

Communication

Conductivity range	0.01...15 mS/cm at 25°C / 77°F (for c=1 the displayed unit is mS/cm for conductivity and kOhm*cm for resistivity)
Output signal	4...20 mA (passive)
Output resolution	20 µA
Field communication	HART® 7 - FSK 1200 physical layer definition on top of the current loop
Filter adjustable	1...60 seconds

Electrical connections

Power supply	15...30 VDC loop powered
Output	4...20 mA + HART® protocol
Load	Minimum 0 Ω; maximum $R_L = [(U_{ext.} - 15 \text{ VDC}) / 22 \text{ mA}]$
HART®	HART® protocol via current output HART®7
Device revision	1
Physical layer	FSK
Device category	Sensor, galvanically isolated
System requirements	250 Ω loop resistance for HART® communication
Multidrop operation	4 mA In a multidrop communication system, up to 32 devices can be connected. For installation in a multidrop communication system please consider the voltage drop for the 250 Ω loop resistance for HART® communication. The supply voltage has to be adjusted.

Approvals

CE	
This device fulfils the statutory requirements of the EC directives. The manufacturer certifies successful testing of the product by applying the CE mark.	
Electromagnetic compatibility:	Directive 2004/108/EC, NAMUR NE 21
Shock resistance:	IEC 60068-2-31, Environmental testing – Part 2: Test Ec
Ex	IECEX: Ex ia IIC T6...T4
	ATEX: II 1 G Ex ia IIC T6...T4
	QPS: Class I, Div 1, Groups A-D, T4...T6 Class I, Zone 0, AEx ia IIC T4...T6 Ex ia IIC T4...T6

① Process connection with minimum inner diameter of 24.5 mm / 0.96" required.

7.3 Dimensions

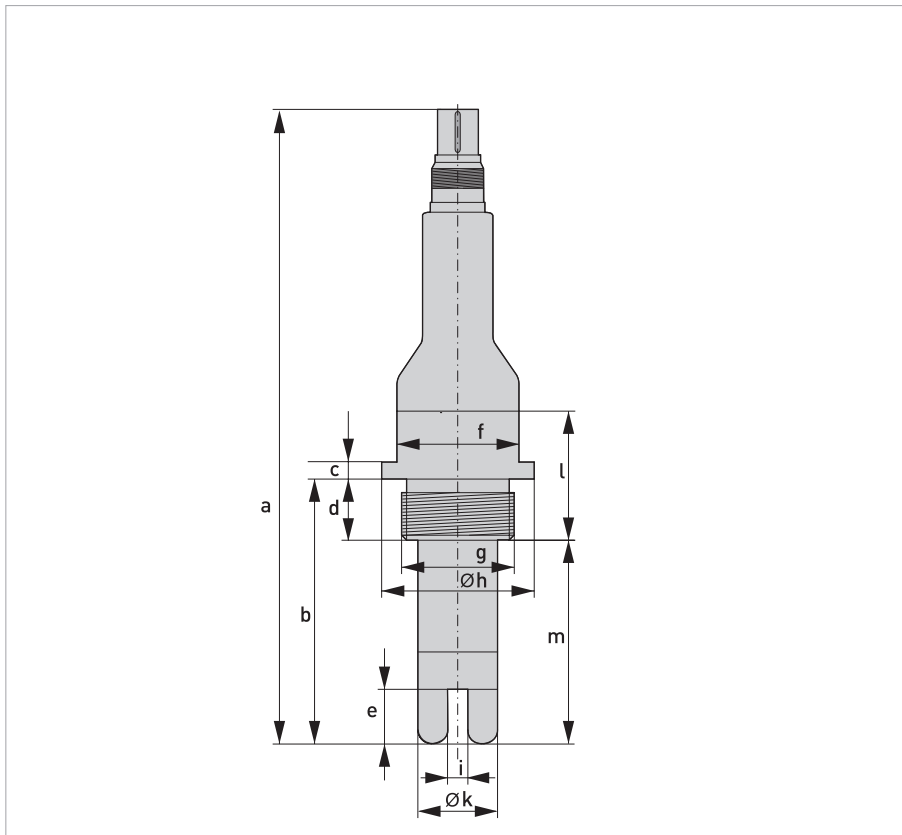

Figure 7-2: SMARTPAT COND 5200

Process connection G3/4 A thread (male)

	Dimensions [mm]	Dimensions [inch]
a	186.2	7.33
b	76	2.99
c	7	0.28
d	16	0.63
e	16.1	0.63
f	WS 36	
g	G3/4 A thread (male)	
h	Ø45	Ø1.77
i	5.6	0.22
k	Ø23.5	Ø0.93
l	38	1.50
m	60	2.36

Process connection 3/4-14 NPT (male)

	Dimensions [mm]	Dimensions [inch]
a	188.2	7.41
b	80	3.15
c	7	0.28
d	20	0.79
e	16.1	0.63
f	WS 36	
g	3/4-14 NPT (male)	
h	Ø45	Ø1.77
i	5.6	0.22
k	Ø23.5	Ø0.93
l	40	1.57
m	60	2.36

8.1 General description

The open HART[®] protocol, which can be used for free, is integrated into the sensor for communication.

Devices which support the HART[®] protocol are classified as either operating devices or field devices. When it comes to operating devices (Master), both manual control units (Secondary Master) and PC-supported workstations (Primary Master) are used in, for example, a control center.

HART[®] field devices include sensors, signal converters and actuators. The field devices range from 2-wire to intrinsically safe versions for use in hazardous areas.

The HART[®] data are superimposed over the analogue 4...20 mA signal via FSK modem. This way, all of the connected devices can communicate digitally with one another via the HART[®] protocol while simultaneously transmitting the analogue signals.

When it comes to the field devices and secondary masters, the FSK or HART[®] modem is integrated. If a PC is used, an external modem must be connected to the serial interface (USB interface). There are, however, other connection variants which can be seen in the following connection figures.

8.2 Software history



INFORMATION!

In the table below, "x" is a placeholder for possible multi-digit alphanumeric combinations, depending on the available version.

Release date	ER version	SW version	HW version	HART [®]	
				Device Revision	DD Revision
2015-08-01	1.0.0_	1.0.x	1.0.x	1	1

HART[®] identification codes and revision numbers

Manufacturer ID:	69 (0x45)
Device:	194 (0xC2)
Device Revision:	1
DD Revision:	1
HART [®] Universal Revision:	7
FC 475 system SW.Rev.:	≥ 3.8
PDM version:	≥ 6.1
FDT version:	≥ 1.2

8.3 Connection variants



CAUTION!

For installation in a multidrop communication system please consider the voltage drop for the 250 Ω loop resistance for HART® communication. The supply voltage has to be adjusted.

The sensor is a 2-wire device with a passive 4...20 mA current output and HART® interface.

- **Multidrop mode is supported**

In a multidrop communication system, up to 32 devices can be connected to a common transmission cable.

- **Burst mode is not supported**

In the burst mode a slave device transfers cyclic pre-defined response telegrams, to get a higher rate of data transfer.

There are two ways of using the HART® communication:

- as Point-to-Point connection and
- as Multidrop connection, with 2-wire connection.

8.3.1 Point-to-Point connection - analogue / digital mode

Point-to-Point connection between the sensor and the HART® Master.

The current output of the sensor is passive.

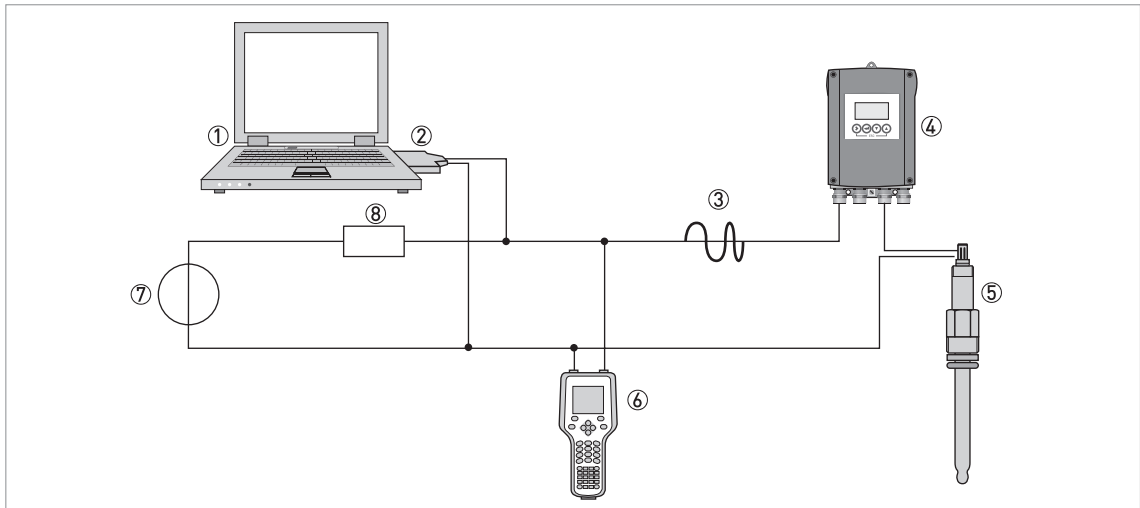

Figure 8-1: Point- to-Point connection (only one primary and one secondary master can communicate with the slave simultaneously)

- ① Primary master with e.g. PACTware™ FDT/DTM
- ② FSK modem
- ③ HART® signal
- ④ SMARTMAC 200 W
- ⑤ SMARTPAT Sensor
- ⑥ Secondary master with HART® DD
- ⑦ Power supply for devices (slaves) with passive current output
- ⑧ Load $\geq 250 \Omega$ (Ohm)

8.4 Inputs/outputs and HART[®] dynamic variables and device variables

HART [®] dynamic variable		
PV	SV	TV
Conductivity (Resistivity)	Resistivity (Conductivity)	Temperature

Code = device variable code

HART [®] device variable	Code	Type
Conductivity	0	linear
Resistivity	1	linear
Temperature	2	linear

The HART[®] dynamic variable PV can be switched between conductivity and resistivity. If the PV is mapped to conductivity, the SV is mapped to resistivity and vice versa.

8.5 Field Communicator 475 (FC 475)

The Field Communicator is a hand terminal from Emerson Process Management that is designed to configure HART[®] and Foundation Fieldbus devices. Device Descriptions (DDs) are used to integrate different devices into the Field Communicator.

8.5.1 Installation

The HART[®] Device Description for the sensor must be installed on the Field Communicator. Otherwise only the functions of a generic DD are available to the user and the entire device control is not possible. A "Field Communicator Easy Upgrade Programming Utility" is required to install the DDs on the Field Communicator.

The Field Communicator must be equipped with a system card with "Easy Upgrade Option". For details consult the Field Communicator User's Manual.

8.6 Field Device Tool / Device Type Manager (FDT/DTM)

A Field Device Tool Container (FDT Container) is basically a PC program used to configure a field device via HART®. To adapt different devices, the FDT container uses a so-called Device Type Manager (DTM).

8.6.1 Installation

If the DTM for the sensor has not yet been installed on the FDT Container, setup is required and is available for download from the website or on CD-ROM. See the supplied documentation for information on how to install and set up the DTM.

8.7 Overview Basic-DD menu tree (for Field Communicator 475)

Main menu	Submenu
1 Measuring value	1 Conductivity
	2 Resistivity
	3 Temperature
	4 Measurand
	5 Loop current
	6 Error
	7 Condensed state
2 Quick setup	1 TAG
	2 Manual hold
	3 I/O
	4 Calibration
3 Logbook	1 Calibration logbook
	2 Error logbook
4 Setup	1 Process input
	2 I/O
	3 I/O HART®
	4 Device
5 Service	1 Service calibration
	2 Service parameter
	3 Sensor lock

8.8 Basic-DD menu tree (details for settings)

1 Measuring value

1 Conductivity	Display of the measured conductivity value on process control system, HART® handheld or SMARTMAC 200 W.
2 Resistivity	Display of the measured resistivity value on process control system, HART® handheld or SMARTMAC 200 W.
3 Temperature	Display of the measured temperature value in °C / °F on process control system, HART® handheld or SMARTMAC 200 W.
4 Measurand	Display of the measured value on process control system, HART® handheld or SMARTMAC 200 W.
5 Loop current	Display of the measured loop current in mA on process control system, HART® handheld or SMARTMAC 200 W.
6 Error	Display of status messages and diagnostic information. For further information refer to <i>Status messages and diagnostic information</i> on page 27.
7 Condensed state	Display of status information icon for sensor according to NAMUR NE 107.

2 Quick setup

1 TAG	1 TAG (set and display TAG) 2 Long Tag (set and display Long TAG) 3 Previous Long TAG (read only)
2 Manual hold	1 Yes 2 No Activate or deactivate the manual hold function.
3 I/O	1 Measurand Conductivity Resistivity 2 Measuring value at 4 mA (set and display) 3 Measuring value at 20 mA (set and display) 4 Time constant (set and display time constant for 4...20 mA update rate (1...60 seconds, 1 second as default))
4 Calibration	1 Product calibration 2 Calibration solution 3 Input cell constant Start calibration procedure. For more information refer to <i>Calibration</i> on page 21.

3 Logbooks

1 Calibration logbook	1 Memory block 2 Calibration method 3 Cell constant 4 Factory cell constant 5 Reference value 6 Calibration solution 7 No. of calibrations 8 Date of calibration
2 Error logbook	1 Memory block 2 Error counter 3 Error 4 Error time

4 Setup

1 Process input	1 Temperature	1 Temperature unit (set and display) 2 Temperature offset (set and display) 3 Date of offset (read only) 4 Temp. compensation (set and display) (off, linear and natural water. Default: linear) 5 Temp. coefficient (set and display) (Only displayed if temp. compensation is set to linear. Default setting: 2%/K) 6 Reference temp. (set and display) (Only displayed if temp. compensation is set to linear. Default setting: 25°C / 77°F)	
	2 Calibration	1 Product calibration 2 Calibration solution 3 Input cell constant For further information refer to <i>Calibration</i> on page 21.	
	3 Cell constant	Display cell constant (read only)	
	4 Maintenance interval	Set and display maintenance interval in days (0...999 days); Default setting: 0	
	5 Time remaining	Display of the remaining maintenance time (read only)	
	6 Reset interval	1 No 2 Yes Reset maintenance interval. Default setting: No	
2 I/O	1 Measurand Conductivity Resistivity 2 Meas. value at 4 mA (set and display) 3 Meas. value at 20 mA (set and display) 4 Time constant (set and display time constant for 4...20 mA, update rate 1...60 seconds) Default setting: 1 second		
3 I/O HART	1 TAG	1 TAG (set and display TAG) 2 Long Tag (set and display Long TAG) 3 Previous Long TAG (read only)	
	2 Message	Set and display HART® message (32 packed ASCII)	
	3 Polling address	1 Polling address (display and input possibility for polling address and loop current mode) 2 Loop current (read only)	
	4 Device variables	1 PV	1 Conductivity 2 Max. conductivity 3 Min. conductivity
	2 SV	1 Resistivity 2 Max. resistivity 3 Min. resistivity	
	3 TV	1 Temperature 2 Max. temperature 3 Min. temperature	

4 Device	1 Information (read only)	1 Sensor information	1 Order code 2 Device name 3 Serial number 4 HART® ID 5 Polling address 6 Manufacturer ID 7 Date of manufacturing 8 SW version 9 HW version
		2 Calibration	1 Measurand 2 Cell constant 3 Calibration solution 4 No. of calibrations 5 SIP counter 6 CIP counter
		3 Operating parameters (OP)	1 Commissioning date 2 Operating hours 3 OP time > max OP t. 4 Max. OP temperature 5 Max. temperature ① 6 Temp. compensation 7 Temp. coefficient ② 8 Reference temp ②
	2 Commissioning	Set date of commissioning	
① - Maximum reached temperature. ② - Displayed only if linear temperature compensation is selected.			

5 Service

1 Service calibration	1 Trimming at 4 mA (+/-) 2 Trimming at 20 mA (+/-)	
2 Service parameter	1 Reset (Reboot sensor)	1 No 2 Yes
	2 Load factory settings (If you select Yes , the following settings will be reset to default: temperature unit, measurand (PV), I/O, calibration interval, 4...20 mA trimming, TAG and Long TAG. Polling address will be set to 0 and loop current will be enabled.	1 No 2 Yes
3 Sensor lock	1 Lock sensor If you select yes the setting is not reversible anymore and the sensor is invalid for use. The HART® communication is not possible anymore.	1 No 2 Yes





KROHNE – Process instrumentation and measurement solutions

- Flow
- Level
- Temperature
- Pressure
- Process Analysis
- Services

Head Office KROHNE Messtechnik GmbH
Ludwig-Krohne-Str. 5
47058 Duisburg (Germany)
Tel.: +49 203 301 0
Fax: +49 203 301 10389
info@krohne.com

The current list of all KROHNE contacts and addresses can be found at:
www.krohne.com

KROHNE