



AFC 030 Technical Datasheet

Electromagnetic flow converter

- Designed and tested for industrial nuclear applications
- Free of programmable electronic components
- LED bar flow indication

The documentation is only complete when used in combination with the relevant documentation for the .

1	Product features	3
<hr/>		
1.1	Solution for nuclear environments	3
1.2	Options and variants	5
1.2.1	Signal converter/flow sensor combination possibilities	5
1.3	Measuring principle.....	6
2	Technical data	7
<hr/>		
2.1	Technical data.....	7
2.2	Dimensions and weights	10
2.3	Flow tables	11
2.4	Measurement accuracy.....	13
3	Installation	14
<hr/>		
3.1	Intended use	14
3.2	Installation specifications	14
3.3	Mounting the wall-housing, remote version.....	15
3.3.1	Pipe mounting	15
3.3.2	Wall mounting	15
3.3.3	Mounting plate of wall-mounted housing	16
3.3.4	Wall-mounted housing	17
4	Electrical connections	18
<hr/>		
4.1	Safety instructions.....	18
4.2	Important notes on electrical connection	18
4.3	Electrical cables for remote device versions.....	19
4.3.1	Notes on signal and field current cables	19
4.3.2	Preparing the signal and field current cables.....	20
4.3.3	Cable specifications	20
4.4	Connecting the signal and the field current cables.....	22
4.4.1	Cable type - L45551	22
4.4.2	PEEK cable H1619 STQ3	23
4.5	Connection diagrams	24
4.6	Grounding	25
4.6.1	Classical method.....	25
4.7	Power supply connection	25
4.7.1	Laying electrical cables correctly.....	26
4.8	Wall-mounted housing, electrical connection of the inputs and outputs	27
5	Notes	29
<hr/>		

1.1 Solution for nuclear environments

The AFC 030 electromagnetic flow converter is designed to measure flow velocity of electrically conductive liquids in radiation areas, for both safety as non-safety applications.

The AFC 030 can be combined with two types of measuring sensors: POWERFLUX 4000 and POWERFLUX 5000.

For maximum reliability and durability the AFC 030 does not contain any programmable electronic components (PEC). It features an adjustable flow range.

The flow is indicated as a percentage of the maximum flow with the LED bar or with a 4 - 20 mA output.

Figure of the display with LED

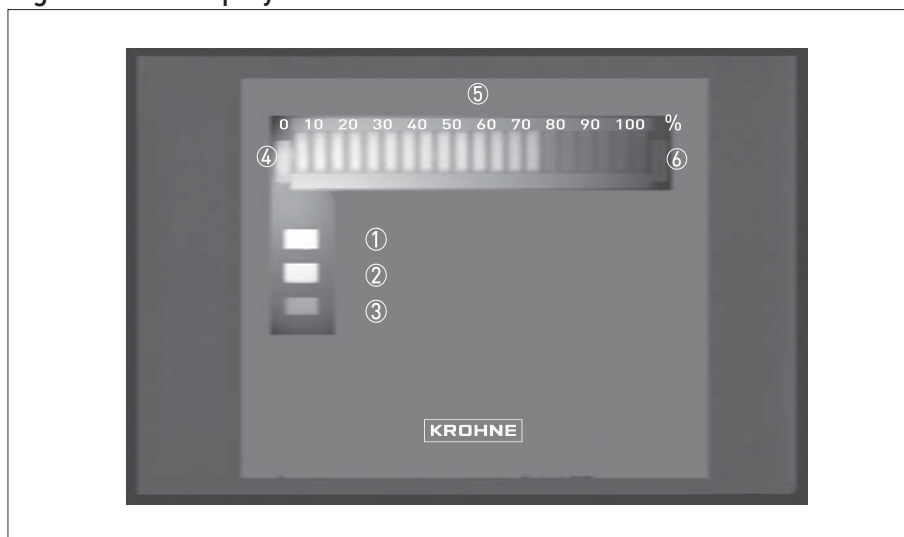

- ① Red LED: Output error
- ② Red LED: Sensor error
- ③ Red LED: Field current error
- ④ Yellow LED: Zero flow / under flow
- ⑤ Green LED Bar: Percentage of flow
- ⑥ Red LED: Over flow

Highlights

- Free of programmable electronic components
- Flow indication as percentage of maximum flow
 - LED bar on the front
 - 4 – 20 mA output
- Adjustable flow range

Industries

- Nuclear

Applications

- Cooling water
- Transport water
- Borated water
- Spent resin

1.2 Options and variants

The AFC 030 is available in wall mount version only. It can be combined with two types of flow sensors: POWERFLUX 4000 and POWERFLUX 5000.



1.2.1 Signal converter/flow sensor combination possibilities

Flow sensor	Flow sensor + signal converter AFC 030
	Remote wall-mounted housing
POWERFLUX 4000	POWERFLUX 4030 W
POWERFLUX 5000	POWERFLUX 5030 W

1.3 Measuring principle

An electrically conductive fluid flows inside an electrically insulated pipe through a magnetic field. This magnetic field is generated by a current, flowing through a pair of field coils.

Inside of the fluid, a voltage U is generated:

$$U = v * k * B * D$$

in which:

v = mean flow velocity

k = factor correcting for geometry

B = magnetic field strength

D = inner diameter of flowmeter

The signal voltage U is picked off by electrodes and is proportional to the mean flow velocity v and thus the flow rate Q . A signal converter is used to amplify the signal voltage, filter it and convert it into signals for totalizing, recording and output processing.

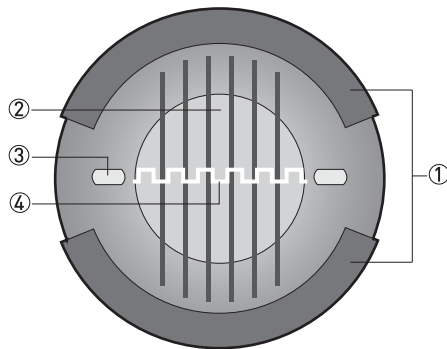

Figure 1-1: Measuring principle

- ① Field coils
- ② Magnetic field
- ③ Electrodes
- ④ Induced voltage (proportional to flow velocity)

2.1 Technical data

- *The following data is provided for general applications. If you require data that is more relevant to your specific application, please contact us or your local sales office.*
- *Additional information (certificates, special tools, software,...) and complete product documentation can be downloaded free of charge from the website (Downloadcenter).*

Measuring system

Measuring principle	Faraday's law of induction
Application range	Measurement of electrically conductive fluids
Measured value	Flow velocity

Design

Construction	The measuring system consists of a flow sensor and a signal converter, It is only available as a remote electronics version.
Flow sensor	
POWERFLUX 4000	DN2,5...1000 / 1/10...40"
POWERFLUX 5000	DN2,5...100 / 1/10...4"
Signal converter	
Remote version (W)	AFC 030 W
Options	
Outputs	Current output 4 - 20 mA
Diagnostic functions	Output error, sensor error, field current error, zero- or low flow, over flow

Display and user interface	
LED bar display	LED display Size LED bar: 22 leds; 20 green led's indicating percentage of maximum flow with, 1 red led (on rightside of the LED bar) to indicate over flow and 1 yellow led (on leftside of the LED bar) to indicate zero- or under flow 3 led's (under the LED bar) to show a diagnostic error
Operating elements	Flow range adjustment with three range jumpers Gk as adjustable resistance value Gk resistance can be changed to adjust flow range and response time

Measuring accuracy

Maximum measuring error	$\pm 1\%$ of the measured value ± 2.5 mm/s For detailed information and accuracy curves, refer to chapter "Accuracy".
Current output electronics	± 10 μ A; ± 100 ppm/ $^{\circ}$ C (typically: ± 30 ppm/ $^{\circ}$ C)
Repeatability	$\pm 0.5\%$ of measured value, minimum 1 mm/s
Calibration	Standard 2 point calibration by direct volume comparison Optional: special calibration on request

Operating conditions

Temperature	
Process temperature	Refer to technical data for the measuring sensor.
Ambient temperature	-40...+65°C / -40...+149°F
	Protect the converter from external heat sources such as direct sunlight as higher temperatures reduce the life cycle of all electronic components.
Storage temperature	-50...+70°C / -58...+158°F
Pressure	
Medium	Refer to technical data for the measuring sensor.
Ambient pressure	Atmospheric
Chemical properties	
Electrical conductivity	All media except water: depends on DN size (also refer to the technical data for the flow sensor)
	Water: $\geq 20 \mu\text{S/cm}$ (DN 2,5...1000)
	Non water: $\geq 10 \mu\text{S/cm}$ (DN 2,5) - $\geq 5 \mu\text{S/cm}$ (DN4...15) - $\geq 1 \mu\text{S/cm}$ (DN25...1000)
State of aggregation	Conductive, liquid media
Solid content (volume)	$\leq 10\%$
Gas content (volume)	$\leq 3\%$
Flow rate	For detailed information, refer to chapter "Flow tables".
Other conditions	
Ingress protection acc. to IEC 529 / EN 60529	W (wall mounted housing): IP65/66 (acc. to NEMA 4/4X)

Installation conditions

Installation	For detailed information, refer to chapter "Installation conditions".
Inlet / outlet sections	Refer to technical data for the flow sensor.
Dimensions and weight	For detailed information refer to chapter "Dimensions and weight".

Materials

Signal converter housing	Standard W version, polyamide - polycarbonate
Flow sensor	For housing materials, process connections, liners, grounding electrodes and gaskets, refer to technical data for the flow sensor.

Electrical connection

General	Electrical connection is carried out in conformity with the VDE 0100 directive "Regulations for electrical power installations with line voltages up to 1000 V" or equivalent national specifications.
Power supply	100...230 VAC (-15% / +10%), 50/60 Hz; 240 VAC + 5% is included in the tolerance range.
Power consumption	AC: 15 VA
Signal cable	For detailed information refer to chapter "Electrical connections". Option: fire resistant (spiral corrugated) multi conductor cable type L45551
Cable entries	Standard: M20 x 1.5 (8...12 mm) Option: ½ NPT, PF ½
Min. bending radius allowed	For all cables, a minimal bending radius $r = 10 \times \varnothing$ (outer diameter cable)
For more information concerning specific application, please contact our support service or your local sales office	

Outputs

General	All outputs are electrically isolated from each other and from all other circuits.
---------	--

Current output	
Output data	Flow
Settings	Q = 0%: 4...20 mA; Q = 100%: 10...21.5 mA Error identification: 3...22 mA

Approvals and certificates

CE	This device fulfils the statutory requirements of the relevant EU directives. The manufacturer certifies successful testing of the product by applying the CE mark. For full information of the EU directives & standards and the approved certifications, please refer to the CE declaration or the manufacturer website.
Nuclear approval	
EMC	IEC 61000-4
Radiation	TID 5E+03 Rad
Vibration	EN 60068-2-6
Seismic	IEC 60980 - 1989 (50 m/s ²)

2.2 Dimensions and weights

Wall version housing

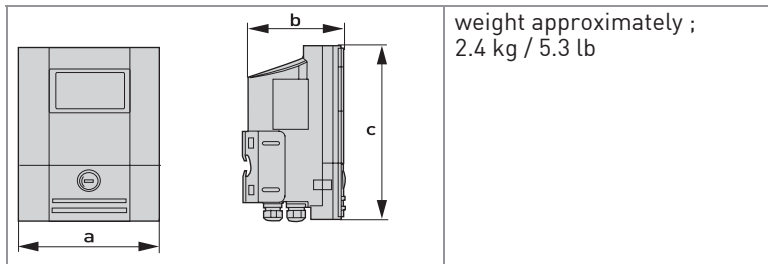

	a	b	c
[mm]	198	138	299
	a	b	c
inch	7.8"	5.4"	11.8"

2.3 Flow tables

Flow rate in m/s and m³/h

v [m/s]	Q _{100 %} in m ³ /h			
	0.3	1	3	12
DN [mm]	Minimum flow	Nominal flow		Maximum flow
2.5	0.005	0.02	0.05	0.21
4	0.01	0.05	0.14	0.54
6	0.03	0.10	0.31	1.22
10	0.08	0.28	0.85	3.39
15	0.19	0.64	1.91	7.63
20	0.34	1.13	3.39	13.57
25	0.53	1.77	5.30	21.21
32	0.87	2.90	8.69	34.74
40	1.36	4.52	13.57	54.29
50	2.12	7.07	21.21	84.82
65	3.58	11.95	35.84	143.35
80	5.43	18.10	54.29	217.15
100	8.48	28.27	84.82	339.29
125	13.25	44.18	132.54	530.15
150	19.09	63.62	190.85	763.40
200	33.93	113.10	339.30	1357.20
250	53.01	176.71	530.13	2120.52
300	76.34	254.47	763.41	3053.64
350	103.91	346.36	1039.08	4156.32
400	135.72	452.39	1357.17	5428.68
450	171.77	572.51	1717.65	6870.60
500	212.06	706.86	2120.58	8482.32
600	305.37	1017.90	3053.70	12214.80
700	415.62	1385.40	4156.20	16624.80
800	542.88	1809.60	5428.80	21715.20
900	687.06	2290.20	6870.60	27482.40
1000	848.22	2827.40	8482.20	33928.80
1200	1221.45	3421.20	12214.50	48858.00
1400	1433.52	4778.40	14335.20	57340.80
1600	2171.46	7238.20	21714.60	86858.40
1800	2748.27	9160.9	27482.70	109930.80
2000	3393.00	11310.00	33930.00	135720.00
2200	4105.50	13685.00	41055.00	164220.00
2400	4885.80	16286.00	48858.00	195432.00
2600	5733.90	19113.00	57339.00	229356.00
2800	6650.10	22167.00	66501.00	266004.00
3000	7634.10	25447.00	76341.00	305364.00

Flow rate in ft/s and US gallons/min

v [ft/s]	Q ₁₀₀ % in US gallons/min			
	1	3.3	10	40
DN [inch]	Minimum flow	Nominal flow		Maximum flow
1/10	0.02	0.09	0.23	0.93
1/8	0.06	0.22	0.60	2.39
1/4	0.13	0.44	1.34	5.38
3/8	0.37	1.23	3.73	14.94
1/2	0.84	2.82	8.40	33.61
3/4	1.49	4.98	14.94	59.76
1	2.33	7.79	23.34	93.36
1.25	3.82	12.77	38.24	152.97
1.5	5.98	19.90	59.75	239.02
2	9.34	31.13	93.37	373.47
2.5	15.78	52.61	159.79	631.16
3	23.90	79.69	239.02	956.09
4	37.35	124.47	373.46	1493.84
5	58.35	194.48	583.24	2334.17
6	84.03	279.97	840.29	3361.17
8	149.39	497.92	1493.29	5975.57
10	233.41	777.96	2334.09	9336.37
12	336.12	1120.29	3361.19	13444.77
14	457.59	1525.15	4574.93	18299.73
16	597.54	1991.60	5975.44	23901.76
18	756.26	2520.61	7562.58	30250.34
20	933.86	3112.56	9336.63	37346.53
24	1344.50	4481.22	13445.04	53780.15
28	1829.92	6099.12	18299.20	73196.79
32	2390.23	7966.64	23902.29	95609.15
36	3025.03	10082.42	30250.34	121001.37
40	3734.50	12447.09	37346.00	149384.01
48	5377.88	17924.47	53778.83	215115.30
56	6311.60	21038.46	63115.99	252463.94
64	9560.65	31868.51	95606.51	382426.03
72	12100.27	40333.83	121002.69	484010.75
80	14938.92	49795.90	149389.29	597557.18
88	18075.97	60252.63	180759.73	723038.90
96	21511.53	71704.38	215115.30	860461.20
104	25245.60	84151.16	252456.02	1009824.08
112	29279.51	97597.39	292795.09	1171180.37
120	33611.93	112038.64	336119.31	1344477.23

2.4 Measurement accuracy

Every electromagnetic flowmeter is calibrated by direct volume comparison. The wet calibration validates the performance of the flowmeter under reference conditions against accuracy limits.

The accuracy limits of electromagnetic flowmeters are typically the result of the combined effect of linearity, zero point stability and calibration uncertainty.

Reference conditions

- Medium: water
- Temperature: +5...+35°C / +41...+95°F
- Operating pressure: 0.1...5 barg / 1.5...72.5 psig
- Inlet section: ≥ 5 DN
- Outlet section: ≥ 2 DN

AFC 030 accuracy

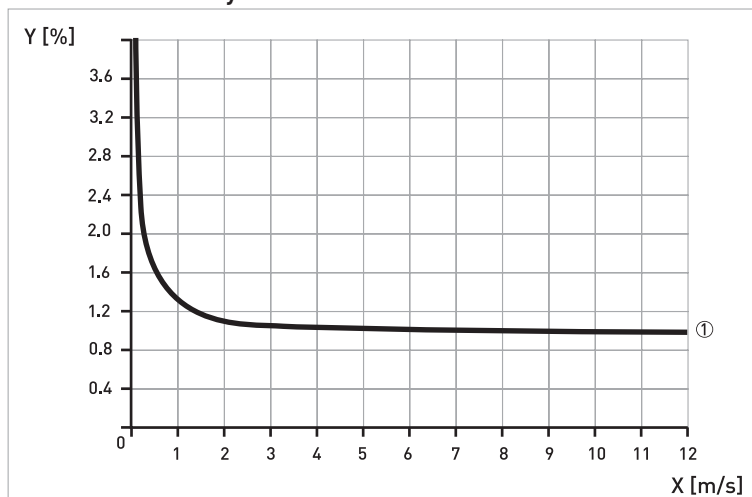

Figure 2-1: X [m/s] : flow velocity
Y [%]: deviation from the actual measured value (mv)

① Minimal accuracy: $\pm 1\%$ of the measured value ± 2.5 mm/s

3.1 Intended use

Responsibility for the use of the measuring devices with regard to suitability, intended use and corrosion resistance of the used materials against the measured fluid lies solely with the operator.

The manufacturer is not liable for any damage resulting from improper use or use for other than the intended purpose.

The electromagnetic flowmeter is designed exclusively to measure the flow of electrically conductive, liquid media.

3.2 Installation specifications

The following precautions must be taken to ensure reliable installation.

- *Make sure that there is adequate space to the sides.*
- *Protect the signal converter from direct sunlight and install a sun shade if necessary.*
- *Signal converters installed in control cabinets require adequate cooling, e.g. by fan or heat exchanger.*
- *Do not expose the signal converter to intense vibrations. The measuring devices are tested for a vibration level in accordance with IEC 68-2-64.*

3.3 Mounting the wall-housing, remote version

Assembly materials and tools are not part of the delivery. Use the assembly materials and tools in compliance with the applicable occupational health and safety directives.

3.3.1 Pipe mounting

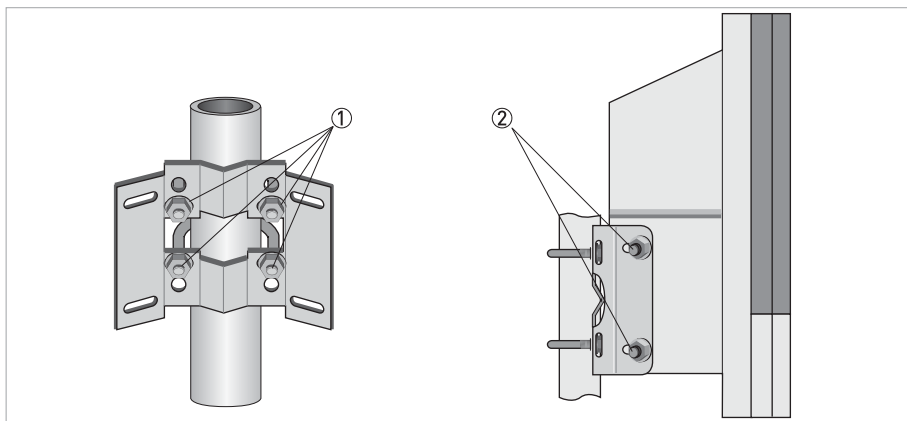

Figure 3-1: Pipe mounting of the wall-mounted housing

- ① Fasten the mounting plate to the pipe with standard U-bolts, washers and fastening nuts.
- ② Screw the signal converter to the mounting plate with the nuts and washers.

3.3.2 Wall mounting

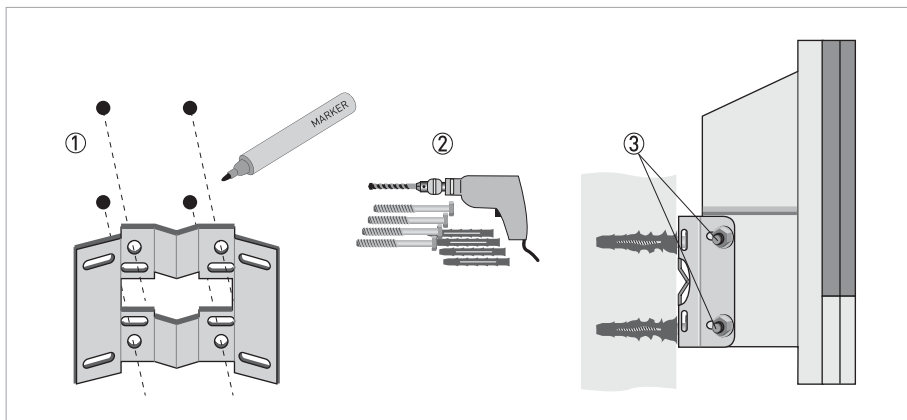
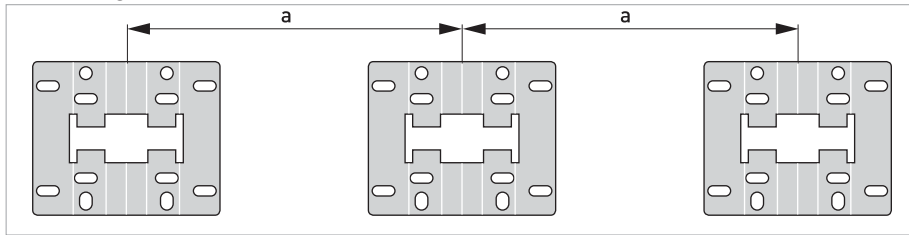

Figure 3-2: Wall mounting of the wall-mounted housing

- ① Prepare the holes with the aid of the mounting plate. For further information refer to *Mounting plate of wall-mounted housing* on page 16.
- ② Fasten the mounting plate securely to the wall.
- ③ Screw the signal converter to the mounting plate with the nuts and washers.

Mounting multiple devices next to each other



$a \geq 240 \text{ mm} / 9.4''$

3.3.3 Mounting plate of wall-mounted housing

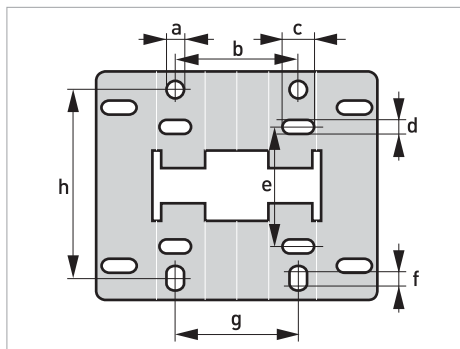

Dimensions in mm and inch

	[mm]	[inch]
a	Ø9	Ø0.4
b	64	2.5
c	16	0.6
d	6	0.2
e	63	2.5
f	4	0.2
g	64	2.5
h	98	3.85

3.3.4 Wall-mounted housing

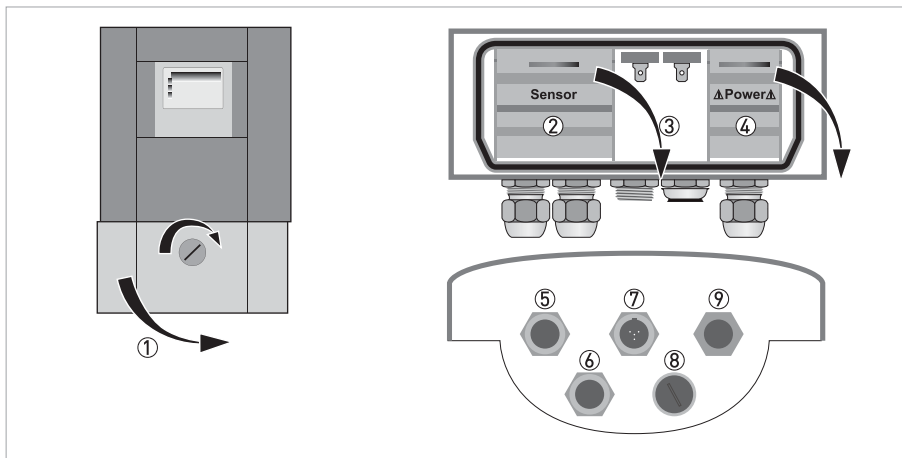

Figure 3-3: Construction of wall-mounted housing

- ① Cover for terminal compartments
- ② Terminal compartment for measuring sensor
- ③ Terminal compartment for outputs
- ④ Terminal compartment for power supply with safety cover (shock-hazard protection)
- ⑤ Cable entry for electrode cable
- ⑥ Cable entry for field current cable
- ⑦ Cable entry for output
- ⑧ Cable entry with blanking plug
- ⑨ Cable entry for power supply

- ① Turn lock to the right and open the cover.
- ② Open safety cover (lid) to enter terminal connections of measuring sensor
- ③ Open safety cover (lid) to enter terminal connections of mains power supply

*Be aware that the cable, type L45551 has a minimal bending radius of 140 mm / 5.5".
For more details see refer to Cable specifications on page 23*

4.1 Safety instructions

All work on the electrical connections may only be carried out with the power disconnected. Take note of the voltage data on the nameplate!

Observe the national regulations for electrical installations!

Observe without fail the local occupational health and safety regulations. Any work done on the electrical components of the measuring device may only be carried out by properly trained specialists.

Look at the device nameplate to ensure that the device is delivered according to your order. Check for the correct supply voltage printed on the nameplate.

4.2 Important notes on electrical connection

Electrical connection is carried out in conformity with the VDE 0100 directive "Regulations for electrical power installations with line voltages up to 1000 V" or equivalent national regulations.

- *Use suitable cable entries for the various electrical cables.*
- *The measuring sensor and signal converter have been configured together at the factory. For this reason, please connect the devices in pairs. Ensure that the measuring sensor constant GK (see nameplates) are identically set.*
- *If delivered separately or when installing devices that were not configured together, set the signal converter to the DN size and GK of the measuring sensor,.*

4.3 Electrical cables for remote device versions

4.3.1 Notes on signal and field current cables

Observe the following notes:

- Place the signal cable with fastening elements.
- It is permissible to lay the signal cable in water or in the ground.
- Cable specifications have to comply to CST 74C068 standard
- The connection of the inner shield is carried out via the stranded drain wire.

Requirements for signal cables provided by the customer

If the signal cable was not ordered, it is to be provided by the customer. The following requirements regarding the electrical values of the signal cable must be observed:

Electrical safety

- To IEC EN 60811-1-1, Common test methods for insulating and sheathing materials of electric cables and optical cables (or equivalent national regulations).

Capacitance of the insulated conductors

- Insulated conductor / insulated conductor < 50 pF/m
- Insulated conductor / shield < 150 pF/m

Insulation resistance

- $R_{ISO} > 100 \text{ G}\Omega \times \text{km}$

Test voltages

- Insulated conductor / inner shield 500 V
- Insulated conductor / insulated conductor 1000 V
- Insulated conductor / outer shield 1000 V

Twisting of the insulated conductors

- At least 10 twists per meter.

*A non-shielded 2-wire copper cable is sufficient for the field current cable. If you nevertheless use shielded cables, the shield must **NOT** be connected in the housing of the signal converter.*

The field current cable is not part of the scope of delivery.

4.3.2 Preparing the signal and field current cables

Assembly materials and tools are not part of the delivery. Use the assembly materials and tools in compliance with the applicable occupational health and safety directives.

The electrical connection of the outer shield is different for the various housing variants. Please observe the corresponding instructions.

4.3.3 Cable specifications

The following cables are supplied with the ordered signal converter / flowmeter:

- Field current cable, PEEK - H1619 STQ 3
- Signal cable, PEEK - H1619 STQ 3
- Signal cable, type L45551.....

The cabling for connection to mains supply and grounding are not supplied. See refer to *Power supply connection* on page 25

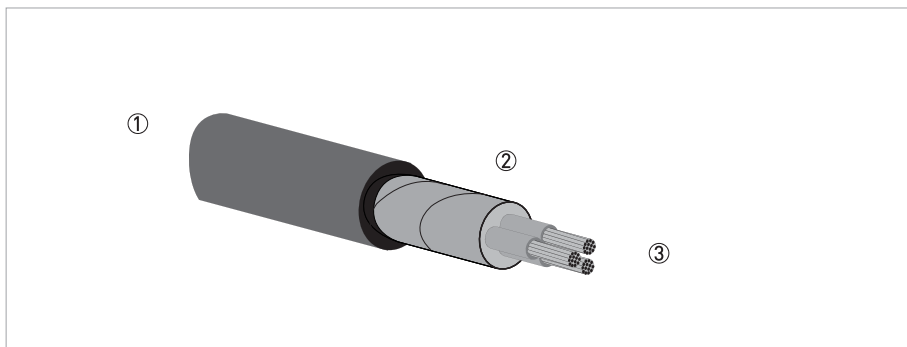

Figure 4-1: PEEK Cable H1619 STQ3

- ① PEEK outer jacket
- ② Silver plated annealed copper braided shield
- ③ Three single twisted wires (polyamide insulated)

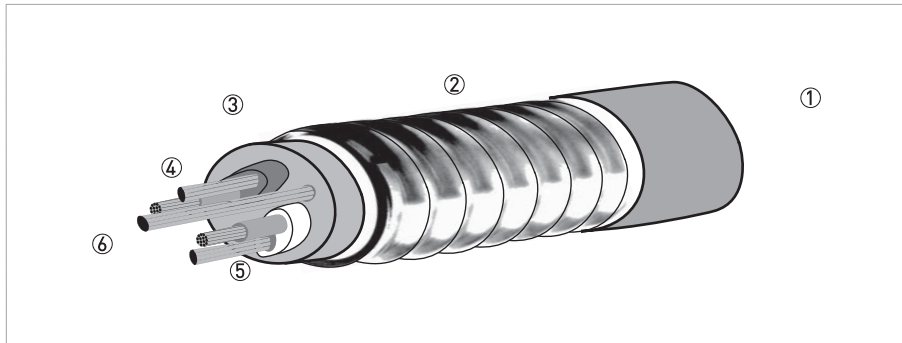

Figure 4-2: Cable type L45551-C21-C16- ...

- ① EVA cross-linked outer jacket
- ② Spiral corrugated copper-tape
- ③ EVA core inner jacket with 2 screened wire
- ④ Screened wire 1 ; double wire PVA insulated
- ⑤ Screened wire 2 ; double wire PVA insulated
- ⑥ Stranded wire ; single wire PE insulated

Both cables are suitable for zone 3 and 4 controlled area with the following specifications :

Cable specifications

Dimension				Conductor dimension			Rating			Static Bending radius
Cable	∅ [mm]	weight [g/m]	wires [n =]	AWG	∅ [mm]	R= Ω/100m	Tmax. [°C]	Vac. [V]	R_Rad . [MGy]	r Min. [mm]
①	5.2	69	3	16	1.5	1.35	200	600	10	55
②	13.9	254	5	20	2.1	3.5	90	300	0.75	140

specification standards;

- ① H1619 STQ3 cable: ASTM - B224 / 298, MIL-DTL-81381, NEMA WC 27500
- ② Type L45551 cable: EN 13602, EN 50290, flame retardant acc. NF C32-070 C1 and IEC 60332-3-23

4.4 Connecting the signal and the field current cables

4.4.1 Cable type - L45551

- The outer shield of the signal cable is connected via an AWG22 cable (140 mm)
- If a shielded field current cable is used, the shield must **NOT** be connected in the housing of the signal converter.
- The Krohne supplied cable has a bending radius: $\geq 70 \text{ mm} / 2.8''$ (one time bending)
For repeated bending ; bending radius $\geq 140 \text{ mm} / 5.6''$

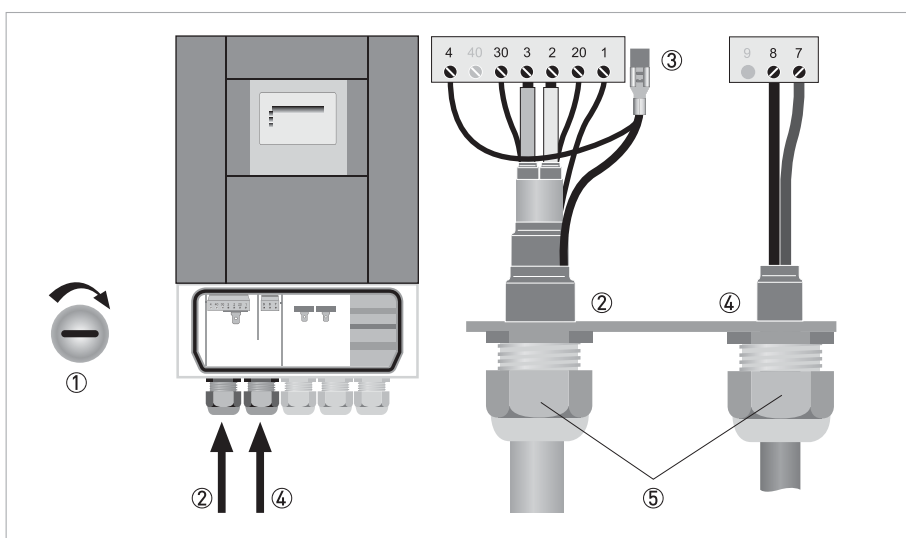

Figure 4-3: Electrical connection of the signal and the field current cables

- ① Open the housing cover.
- ② Pass the prepared signal cable through the cable entry and connect the corresponding stranded drain wires and conductors.
- ③ Connect the drain wire of the outer shield.
- ④ Pass the prepared field current cable through the cable entry and connect the corresponding conductor.
Any shield that is present must **NOT** be connected.
- ⑤ Tighten the screw connections of the cable entry and close the housing cover.

Ensure that the housing gasket is properly fitted, clean and undamaged.

4.4.2 PEEK cable H1619 STQ3

- The outer shield of the signal cable is connected via an AWG22 cable (140 mm)
- If a shielded field current cable is used, the shield must **NOT** be connected in the housing of the signal converter.
- The Krohne supplied cable has a bending radius: $\geq 25 \text{ mm} / 1''$ (one time bending)
For repeated bending ; bending radius $\geq 50 \text{ mm} / 2''$

- ① Open the housing cover.
 - ② Pass the prepared signal cable through the cable entry and connect the corresponding stranded drain wires and conductors.
 - ③ Connect the drain wire of the outer shield.
 - ④ Pass the prepared field current cable through the cable entry and connect the corresponding conductor.
- Any shield that is present must **NOT** be connected.
- ⑤ Tighten the screw connections of the cable entry and close the housing cover.

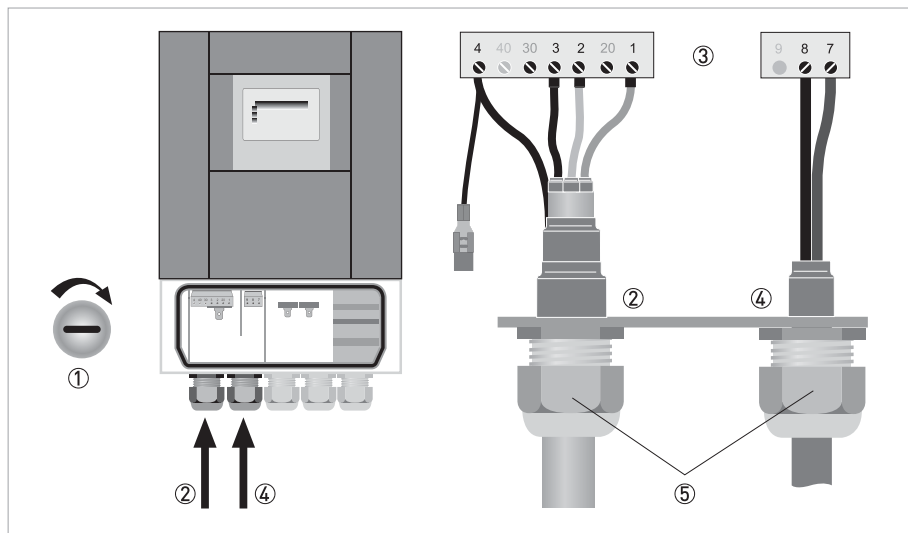

Figure 4-4: Electrical connection of the signal and the field current cables

Ensure that the housing gasket is properly fitted, clean and undamaged.

4.5 Connection diagrams

The device must be grounded in accordance with regulations in order to protect personnel against electric shocks.

Connection diagram, PEEK cable

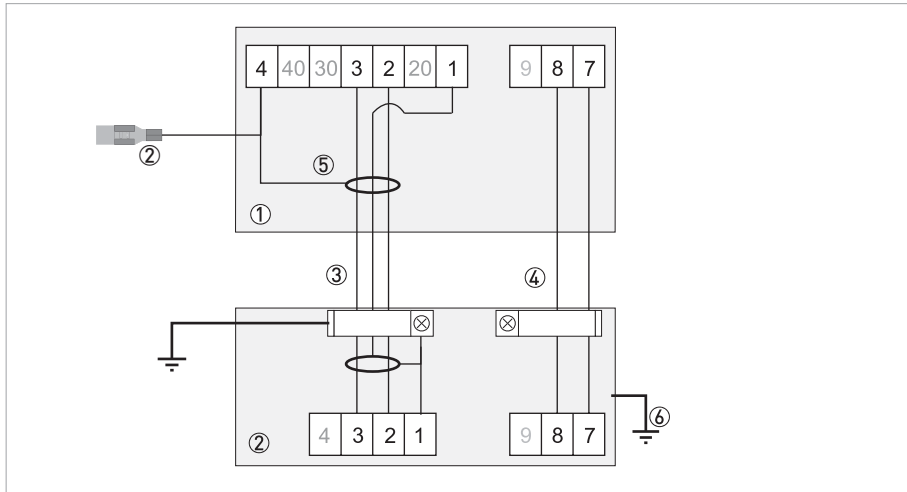

Figure 4-5: Connection diagram for measuring sensor to converter

- ① Electrical terminal compartment in housing of the signal converter.
- ② Connection box of measuring sensor
- ③ Signal cable
- ④ Field current cable
- ⑤ Terminal 4 is connected to shield of cable
- ⑥ Functional ground FE

Connection diagram, cable L45551

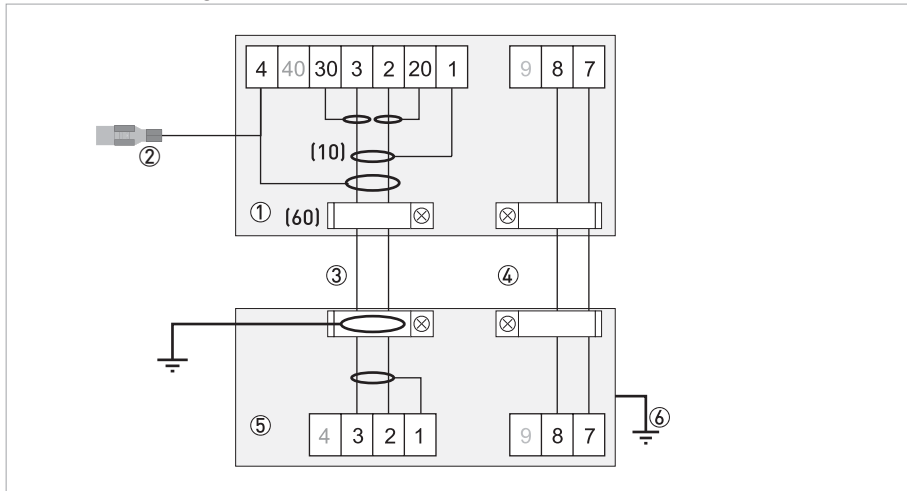

Figure 4-6: Connection diagram for measuring sensor to converter

- ① Electrical terminal compartment in housing of the signal converter.
- ② Wire on terminal 4 (cable lug connection in signal converter)
- ③ Signal cable
- ④ Field current cable
- ⑤ Connection box of measuring sensor
- ⑥ Functional ground FE

4.6 Grounding

The device must be grounded in accordance with regulations in order to protect personnel against electric shocks.

4.6.1 Classical method

There should be no difference in potential between the flow sensor and the housing or protective earth of the signal converter!

- The flow sensor must be properly grounded.
- The grounding cable should not transmit any interference voltages.
- Do not use the grounding cable to connect any other electrical devices to ground at the same time.
- The flow sensors are connected to ground by means of a functional grounding conductor FE.
- Special grounding instructions for the various flow sensors are provided in the separate documentation for the flow sensor.
- The documentation for the flow sensor also contain descriptions on how to use grounding rings and how to install the flow sensor in metal or plastic pipes or in pipes which are coated on the inside.

4.7 Power supply connection

The device must be grounded in accordance with regulations in order to protect personnel against electric shocks.

For devices used in hazardous areas, additional safety notes apply; please refer to the Ex documentation.

- The protection category depends on the housing versions (IP65...67 to IEC 529 / EN 60529 or NEMA4/4X/6).
- The housings of the devices, which are designed to protect the electronic equipment from dust and moisture, should be kept well closed at all times. Creepage distances and clearances are dimensioned to VDE 0110 and IEC 664 for pollution severity 2. Supply circuits are designed for overvoltage category III and the output circuits for overvoltage category II.
- Fuse protection ($I_N \leq 16$ A) for the infeed power circuit, as well as a separator (switch, circuit breaker) to isolate the signal converter must be provided close to the device. The separator must conform to IEC 60947-1 and IEC 60947-3 and must be marked as the separator for this device.

100...230 VAC (tolerance range: -15% / +10%)

- Note the power supply voltage and frequency (50...60 Hz) on the nameplate.
- The protective ground terminal **PE** of the power supply must be connected to the separate U-clamp terminal in the terminal compartment of the signal converter

240 VAC + 5% is included in the tolerance range.

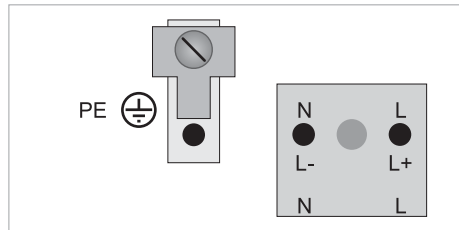

The protective conductor contacts must not be used to loop through the PE connection.

4.7.1 Laying electrical cables correctly

Figure 4-7: Protect housing from dust and water

- ① Lay the cable in a loop just before the housing.
- ② Tighten the screw connection of the cable entry securely.
- ③ Never mount the housing with the cable entries facing upwards.
- ④ Seal cable entries that are not needed with a plug.

4.8 Wall-mounted housing, electrical connection of the inputs and outputs

All work on the electrical connections may only be carried out with the power disconnected. Take note of the voltage data on the nameplate!

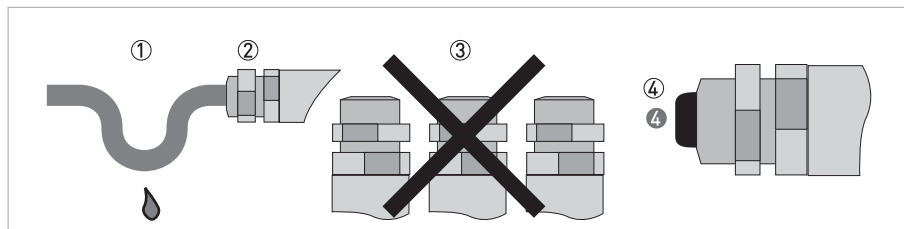
- The shield must be electrically connected using 6.3 mm / 0.25" push-on connector (insulation to DIN 46245) in the I/O terminal compartment.
- Terminal A+ is only operable in the basic version.

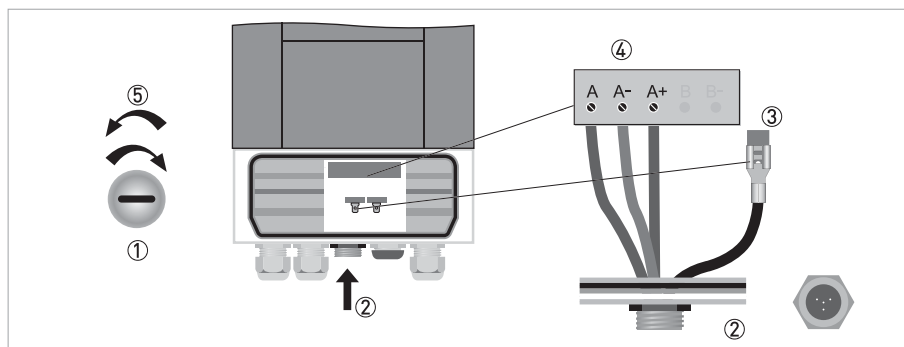

Figure 4-8: Connection IO plug

1. To open lower door of signal converter
2. 4 pin connector IO cable
3. Push-on connector in terminal compartment
4. Connected wiring A, A- & A+
5. To close lower door of signal converter

Ensure that the housing gasket is properly fitted, clean and undamaged.

Only the output connections (4-20mA) A, A- , A+ and ground are connected in the AFC 030 signal converter. The connection diagrams below shows the possible output connections to use. Connections B, B+, C, C+, D, and D+ are not connected.

4-20mA, passive mode (external supply)

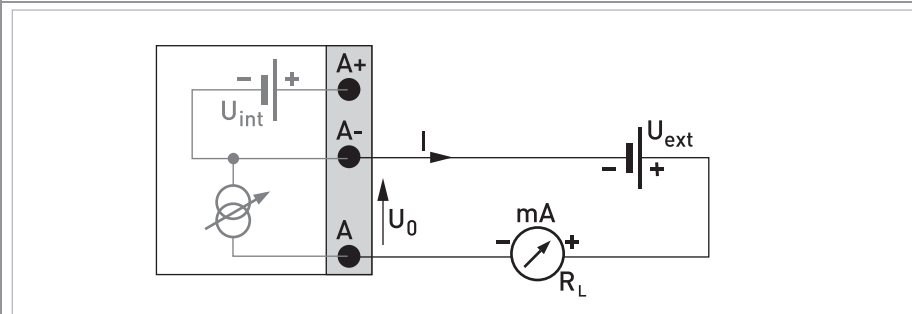

4-20mA, passive mode, grounded (external supply)

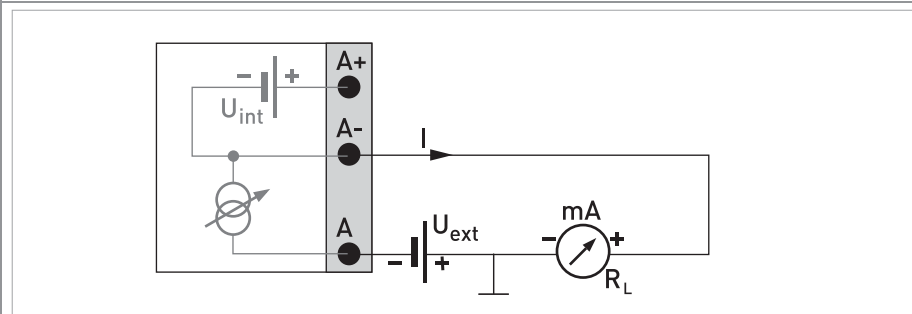

4-20mA, active mode (internal supply)

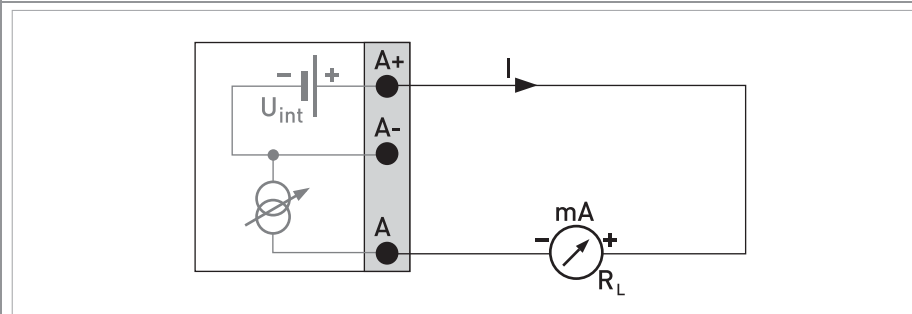







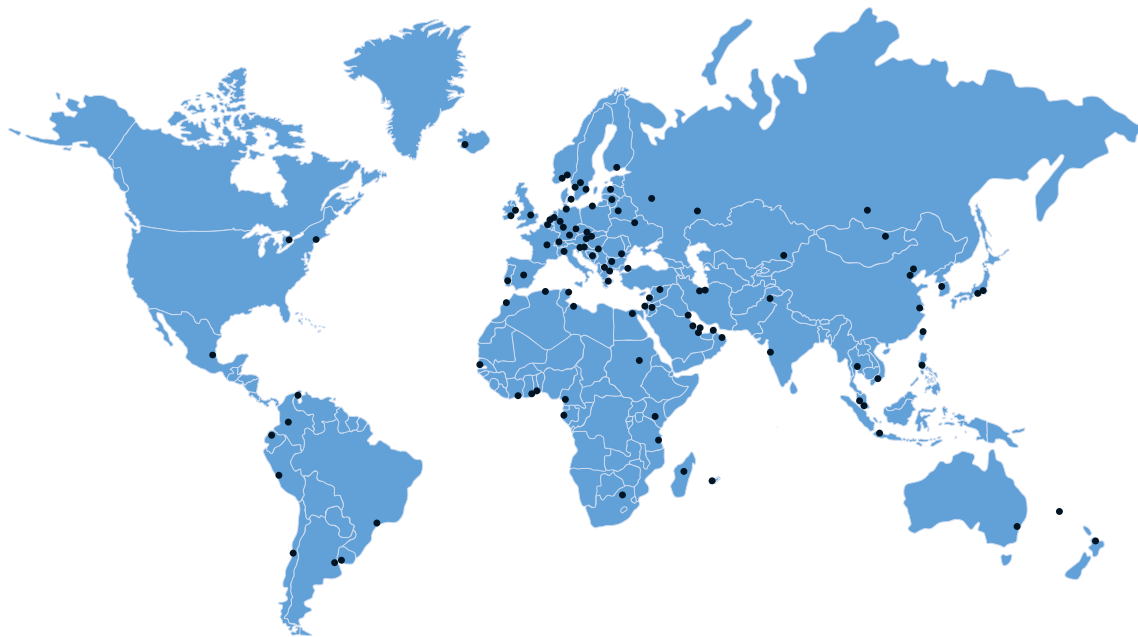

KROHNE – Process instrumentation and measurement solutions

- Flow
- Level
- Temperature
- Pressure
- Process Analysis
- Services

Head Office KROHNE Messtechnik GmbH
Ludwig-Krohne-Str. 5
47058 Duisburg (Germany)
Tel.: +49 203 301 0
Fax: +49 203 301 10389
info@krohne.com

The current list of all KROHNE contacts and addresses can be found at:
www.krohne.com

KROHNE