



H250 Technical Datasheet

Variable Area Flowmeter

- Rugged design for extreme operating conditions
- Local indication without the need for auxiliary power
- Flexible and can be adapted to meet customer-specific requirements



The standard solution in the process industry

The all-metal flowmeter H250 is used in the measurement of volume or mass flow of liquids, gases, and vapors.

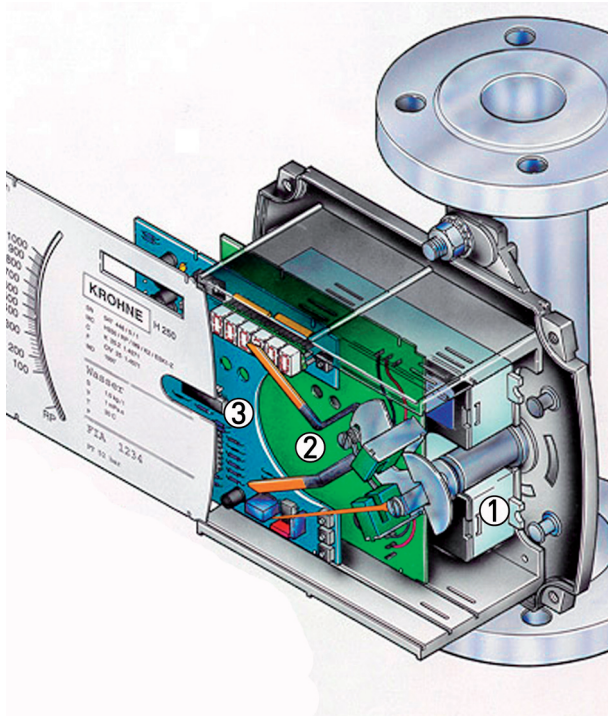

- ① 4...20 mA-output / Profibus PA
- ② Limit monitors
- ③ Flow Counter

Highlights

- Consistently used overall length concept
- Low loss of pressure for gas applications
- Measurement at operating pressures up to 3000 bar
- Measurement at extremely low and high process temperatures (-200°C to +300°C)
- Fast non-interruptive retrofitting of the modules
- The only EHEDG-certified variable area flow meter permitted for use with food & pharmaceuticals.
- Dead space-free, CIP and SIP capable
- SIL 2 certified

Industries

Can be used in all industrial sectors, for example:

- Chemical
- Petrochemical
- Pharmaceutical
- Mechanical engineering
- Food and Beverage
- Oil and Gas
- Iron, Steel and Metals
- Power plants
- Pulp and Paper
- Water and Wastewater

Applications

- Continuous gas and liquid measurement
- Measurement of non-conductive materials
- Industrial burner controlling
- Compressor monitoring
- Dry-run protection of pumps

Examples of customised variants

Stainless steel indicator housing (H250/M9R)



For particularly rough environmental conditions, the M9 indicator housing is optionally available in stainless steel.

This guarantees its reliable use in corrosive atmospheres caused by operational immissions.

When installed outdoors, external influences such as salt fog or contaminated precipitation no longer lead to corrosion.

The stainless steel housing is equally well-suited for use in splash water zones such as in the food and luxury food industry.

H250F Food & Pharmaceutical



The only EHEDG-certified variable area flowmeter approved for the food and pharmaceutical industry features.

Smooth stainless steel surfaces with a surface roughness of the parts in contact with the medium of $\leq 0.8 \mu\text{m}$ or $0,6 \mu\text{m}$, which makes it difficult for deposits to stick and easy to clean.

Combined with a design devoid of dead spaces and stagnation zones, microorganisms cannot stick and multiply.

The measuring instruments can be cleaned (CIP) and sterilized (SIP) while intact.

There are suitable connections and FDA conforming materials for the food and pharmaceutical industry.

PTFE/ceramic liner for aggressive media



All components coming into contact with the medium can also be made of ceramic or PTFE, which means they can be used for virtually all acids and alkalis.

Process temperature $T_{max} = 70^{\circ}\text{C}$ (PTFE)

Process temperature $T_{max} = 250^{\circ}\text{C}$ (ceramic)

Accuracy class 2.5

Designs for special installation positions (H 250H / H 250U)



Variable area flowmeters-generally feature a vertically positioned measuring cone through which the medium flows from bottom to top, raising a float against the weight

If the installation structure does not permit it otherwise, the versions H 250H for horizontal or H 250U for reverse installation position (from top to bottom) are used.

The reset force lacking in the weight of the float is replaced by a spring.

Indication variants

Indicator M9 (Modular functionality)

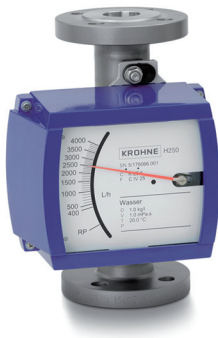

Simple, low-cost installation:

- Measure and display without auxiliary power supply
- Large scale for good readability
- Modular and flexible to adapt to customer-specific applications
- 2 limit switches (NAMUR or 3-wire transistor)
- 2-wire analog output 4...20mA with HART
- Profibus PA interface
- 6-digit flow counter with pulse output (non Ex)
- SIL 2 certified
- Intrinsically safe and nonincendive for use in hazardous areas (ATEX, FM, NEPSI)

Indicator M10 (Integrated functionality)



Integrated functionality

- Graphic display for measured value and counter display
- 2 limit switches (NAMUR or 3-wire transistor)
- 2-wire analog output 4...20mA with HART
- 12-digit flow counter with pulse output and reset input

Operated using keys or magnetic stylus

Explosion proof enclosure for use in hazardous areas (ATEX, FM, CSA, NEPSI)

Indicator M8 (compact)



- Compact, space saving design
- Intrinsically safe for use in hazardous areas (ATEX)

M8M

- Mechanical indicator -No auxiliary power needed
- Optional 2 limit switches (NAMUR)

M8E

- Electronic bargraph indicator
- 2-wire analog output 4...20mA with HART

Technical data

Application range	Flow measurement of liquids, gases and vapors
Function / measuring principle	Variable area measuring principle
Measuring accuracy H250 /RR /HC /F	1.6 acc. to directive VDI / VDE 3513, sheet 2
Measuring accuracy H250/C (ceramic/PTFE)	2.5 acc. to directive VDI / VDE 3513, sheet 2
Inlet run	≥ 5 x DN
Outlet run	≥ 3 x DN
Max. Operating pressure PS	per pressure equipment directive 97/23/EC
Max. Test pressure PT	per pressure equipment directive 97/23/EC or AD 2000-HP30
Max. Process temperature TS	300 °C
Min. required operating pressure	Twice as great as pressure loss (see measuring ranges)
Suspended solid particle decrease during gas measurement recommended:	
DN15 ... DN25 / ½" ... 1"	Operating pressure less than 0.3 bar
DN50 ... DN100 / 2" ... 4"	Operating pressure less than 0.2 bar

Materials

Device	Measuring tube	Flanges / raised face	Float	Float stop / guide	Circular orifice
H250 /RR	CrNi-steel 1.4404 ①	CrNi-steel 1.4404 massive ①	CrNi-steel 1.4404 ①	CrNi-steel 1.4404 ①	-
H250/HC	Hastelloy C4 (2.4610)	CrNi-steel 2.4610 mit Hastelloy C4 (2.4610) plated ①	Hastelloy C4 (2.4610)	Hastelloy C4 (2.4610)	-
H250/C ②	CrNi steel 1.4571 with TFM/PTFE liner ③	CrNi-steel 1.4571 with TFM/PTFE liner ③	PTFE or Al203 with FFKM seal	Al203 and PTFE	Al203
H250/F ④	CrNi steel 1.4435	CrNi steel 1.4435	CrNi steel 1.4435	CrNi steel 1.4435	-

① CrNi-steel 1.4571 on request, clamp connections CrNi-steel 1.4435

② DN100 / 4" only PTFE

③ TFM/PTFE (electrically nonconductive)

④ wetted surfaces Ra ≤ 0.8 µm

Further options:

- Special material on request: e.g. SMO 254, Titan, 1.4435
- Suspended solid particle decrease: ceramic or PEEK
- Seal for devices with internal thread: O-ring FPM / FKM

Temperatures

H250/M9 - mechanical indicator without power supply

	Float	Liner	Measuring temp. [°C]	Ambient temp. [°C]
H250/RR	Stainless steel	Stainless steel	-196 ... +300	-40...+120
H250/RR Screw fitting				-20...+120
H250/HC	Hastelloy C4	Hastelloy C4	-196 ... +300	-40...+120
H250/C	PTFE	PTFE	-196 ... +70	-40 ... +70
H250/C	Ceramic	PTFE	-196 ... +150	-40 ... +70
H250/C	Ceramic	TFM	-196 ... +250	-40 ... +120
H250H - H250U	stainless steel	stainless steel	-40 ... +100	-20...+90

H250/M9 with electrical components

DIN	ASME	Version with	TS °C (Tamb. <40 °C)		TS °C (Tamb. <60 °C) *	
			Standard	HT	Standard	HT
DN15, DN25	1/2", 1"	ESK2A, ESK3-PA	+200	+300	+180	+300
		ESK2A with counter	+200	+200	+80	+130
		Limit switches SC.. SJ..	+200	+300	+200	+300
		Limit switches SB..	+200	+300	+130	+295
DN 50	2"	ESK2A, ESK3-PA	+200	+300	+165	+300
		ESK2A with counter	+180	+300	+75	+100
		Limit switches SC.. SJ..	+200	+300	+200	+300
		Limit switches SB..	+200	+300	+120	+195
DN 80, DN100	3", 4"	ESK2A, ESK3-PA	+200	+300	+150	+250
		ESK2A with counter	+150	+270	+70	+85
		Limit switches SC.. SJ..	+200	+300	+200	+300
		Limit switches SB..	+190	+300	+110	+160

* without heat insulation measures, a heat-resistant cable is necessary (continuous operating temperature of the cable to be used: 100°C)

Abbreviations

HT	High temperature version
ESK2A	Transmitter, two-wire technology 4 ... 20 mA
ESK3-PA	PROFIBUS PA transmitter
SC	Limit switch type NAMUR
SJ	Limit switch type NAMUR safety oriented
SB	Limit switch type 3-Leiter, PNP normally open

Min. ambient temperatures Tamb with ESK and limit switches

Limit switches	-25 °C
ESK2A - ESK3-PA	-40 °C

Temperatures H250 /M8 /M10

M8M

Max. Tmed. at Tamb. +60°C	+200
Min. measuring temperature TS without limit monitor	-80
Min. measuring temperature TS with limit monitor	-25
Max. ambient temperature Tamb.	+70
Min. ambient temperature Tamb.	-25

M8E

Max. Tmed. at Tamb. +40°C	+200
Max. Tmed. at Tamb. +50°C	+185
Max. Tmed. at Tamb. +60°C	+145
Min. Tmed.	-25
Max. ambient temperature Tamb.	+70
Min. ambient temperature Tamb.	-25

M10

Max. Tmed. at Tamb. +60°C	+200
Min. measuring temperature TS	-80
Max. ambient temperature Tamb.	+75
Min. ambient temperature Tamb.	-40

Technical data for indicators M8 M9 M10

M8M limit switch

Clamp connection	2.5mm ²		
Limit switches	SC3,5-N0-Y	SJ3,5-SN	SJ3,5-S1N
Type	2-wire NAMUR	2-wire NAMUR	2-wire NAMUR
Switch configuration	Normally closed	Normally closed	Normally open
Nominal voltage U ₀	8 VDC	8 VDC	8 VDC
Pointer shaft not read	≥3 mA	≥3 mA	≤1 mA
Pointer shaft read	≤1 mA	≤1 mA	≥3 mA

M8E current output

Cable gland	M16 x 1.5	
Pipe diameter	8...10 mm	
Clamp-type terminal	4 mm ²	
Measuring signal	4...20 mA 0...100% flow value	Two-wire technology
Power supply	14.8...30 VDC	
Min. power supply at HART™	20.5 VDC	
Power supply effect	< 0.1%	
Input impedance dependence	< 0.1%	
Temperature effect	< 10µA / K	
Max. input impedance / load	640 Ohm (30 VDC)	
Min. load at HART™	250 Ohm	
M8E HART™ Parameterization		
Manufacturer's name (code)	KROHNE Messtechnik (69)	
Model name	M8E (230)	
HART™ Protocol revision	5.1	
Device revision	1	
Physical layer	FSK	
Device category	Transmitter	

M8E process variable

M8E process variable flowrate	Values [%]	Signal output [mA]
Over range	+105 (± 1%)	20.64...20.96
Device error identification	> 110	> 21.60
Maximum	112.5	22
Multi drop operation	-	4.5

Indicator M9

M9 Cable fitting

Cable fitting	Material	Cable diameter
M 16x1,5 Standard	PA	5...10 mm
M 20x1,5	PA	8...13 mm
M 16x1,5	Nickel-plated brass	5...9 mm
M 20x1,5	Nickel-plated brass	10...14 mm

M9 limit switches

Clamp connection	2,5mm ²			
Limit switches	SC3,5-N0-Y	SJ3,5-SN	SJ3,5-S1N	SB3,5-E2
Type	2-wire NAMUR	2-wire NAMUR	2-wire NAMUR	3-wire
Switch configuration	Normally closed	Normally closed	Normally open	PNP Normally open
Nominal voltage U0	8 VDC	8 VDC	8 VDC	10...30 VDC
Pointer shaft not read	≥3 mA	≥3 mA	≤1 mA	≤ 0.3 VDC
Pointer shaft read	≤1 mA	≤1 mA	≥3 mA	Ub - 3 VDC
Continuous current	-	-	-	max. 100 mA
No-load current I0	-	-	-	≤15 mA

M9 current output ESK2A

Clamp connection	2.5 mm ²	
Power supply	12...30 VDC	
Measurement signal	4.00...20.00 mA 0...100% flow value	Two-wire technology
Power supply	12...30 VDC	
Min. power supply for HART™	18 VDC	
Effect of supply power	< 0.1%	
External resistance dependence	< 0.1%	
Temperature influence	< 5 μA / K	
Max. external resistance / load impedance	800 ohms (30 VDC)	
Min. load with HART™	250 ohms	

M9 ESK2A HART

ESK2A HART™ parameter configuration		
Name of manufacturer (code)	KROHNE Messtechnik (69 = 45h)	
Name of model	ESK2A (226 = E2h)	
HART™ protocol revision	5.9	
Device revision	1	
Physical layer	FSK	
Device category	Transmitter non dc isolated device	

M9 ESK2A process variable

ESK2A process variable flow rate	Values [%]	Signal output [mA]
Over range	+102.5 (± 1%)	20.24...20.56
Device error detection	> 106.25	> 21.00
Maximum	131.25	25
Multi-drop operation	-	4.5
Lift-off voltage	12 VDC	

M9 ESK totalizer

Clamp connection	2,5 mm ²	
Power supply	10...30 VDC	
R _{ext.} Current loop	0...600 Ohm	
Power consumption	max. 2,5 watts	
Indicating error	< 1%	maximum one scalar unit
Max. reset voltage	30 VDC	
Min. reset pulse	300 ms	
Software firmware version	1.19	
Power supply	10...30 VDC	
Max. current	50 mA	
Max. dissipation	250 mW	
T on	80 ms	fixed pulse width
T off	depends on flow rate	
V on	U _b – 3 VDC	
V off	0 Volt	
Pulse value	1 pulse = 1 display totalizer advance	= 1 flow unit (1 liter , 1 m ³)

Indicator M9 ESK3PA- Profibus PA

Clamp connection	2,5mm ²	
Bus cable R´	15...150 Ohm/km	
Bus cable L´	0,4...1 mH/km	
Bus cable C´	80...200 nF/km.	

M9 ESK3PA Hardware

Hardware	according to IEC 1158-2 and FISCO model	
Power supply	9...32 VDC	
Base current	12 mA	
Starting current	< Base current	
FDE	< 18 mA	
Accuracy as per VDI/ VDE 3513	1,6	
Measurement resolution	< 0.1 % of full-scale value	
Temperature influence	< 0.05 % / K of full-scale value	
Software- firmware version	1.01/000418	
Ident No.	3184980200	

M9 ESK3PA Software

Software		
GSD	Device master file	
Device profile	Profiles B, V3.0	
Function blocks		
Flow rate (AI0)	Volume or mass	
Totalizer (TOT0)	Volume totalizer	Default units: [m3]
Totalizer (TOT1)	Mass totalizer	Default units: [kg]
Address range	0...126, default 126	
SAP`s	Service_Access_Points	
DD	Device-Description	

Indicator M10

M10 indicator cable fitting

Cable fitting	none	(standard)
M 20x1.5	on request	
M 20x1.5 Ex d	on request	

M10 current output

current output	Two-wire technology	
Power supply	24 VDC +/- 30	
Signal output current	4...20 mA	
Effect of supply power	< 0.1	
External resistance dependence	< 0.1	
Temperature influence	< 5 μ A/K	
External resistance / load impedance	\leq 630 ohms	
External resistance with HART	\geq 250 ohms	

M10 HART

Name of manufacturer (code)	KROHNE Messtechnik (69)	
Name of model	M10A	
HART™ protocol revision	5.1	
Device revision	1	
Physical layer	FSK	
Device category	Transmitter	

M10 process variable

	Values [%]	Signal output [mA]
Over range	+105 (\pm 1%)	20.64...20.96
Device error detection	> 110	> 21.60
Maximum	112.5	22
Multi-drop operation	-	4.5

M10 digital output

Binary outputs	galvanically isolated	
Operating mode	Binary output	NAMUR or open collector
configurable as	switching contact	normally open / normally closed or
	pulse output	max. 10 pulses per second
NAMUR binary output		
Power supply	8 VDC	
Signal current	> 3 mA if switching value not reached; < 1 mA when switching value reached	
Open collector binary output		
Power supply	8...30 VDC	
Pmax	500 mW	
I _{max}	100 mA	

M10 reset input

Binary input	galvanically isolated	
Operating mode	Counter reset	
configurable as	active HI / active LO	
Voltage level	5...30 VDC	
Current drawn	≤1 mA	
Pulse length (active)	≥ 500 ms	

Dimensions

Dimensions of H250/M9

M9
Front view

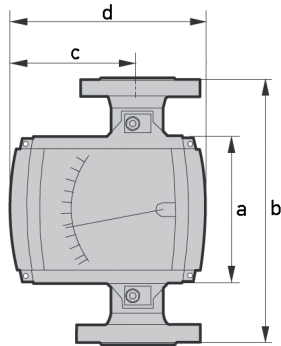

M9
Side view

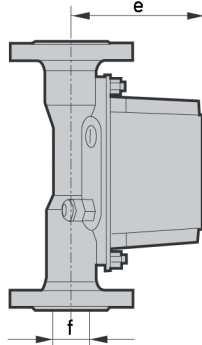

M9
with heating

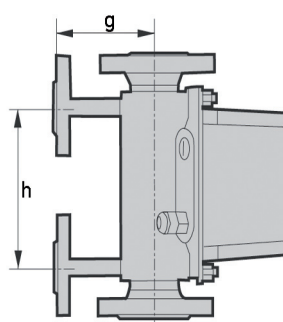

M9
HT high-temperature

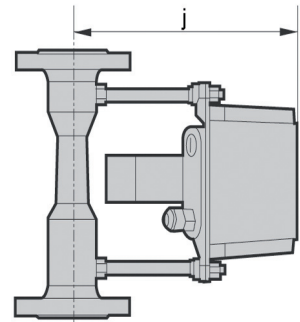

	Dimensions [mm]								
	a	b	c	d	e	Ø f	g	h	j
DN15 PN40	138	250	110,5	181	107	20	100	150	187
DN25 PN40	138	250	110,5	181	119	32	106	150	199
DN50 PN40	138	250	123,5	181	132	65	120	150	212
DN80 PN16	138	250	123,5	181	148	89	160	150	228
DN100 PN16	138	250	123,5	181	158	114	150	150	232
Overall height b of H250/C (ceramic/PTFE) from 3" / 300 lbs: 300 mm									
ISO 228		300							
H250/F		250							

ISO 228
Female thread
screwed

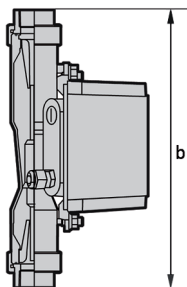

ISO228
Female thread
welded

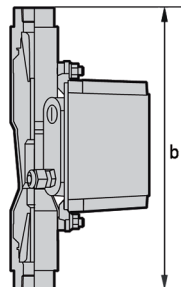

H250/F
Clamp connection

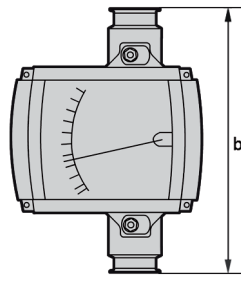

H250/F
Screw connection
DIN 11851

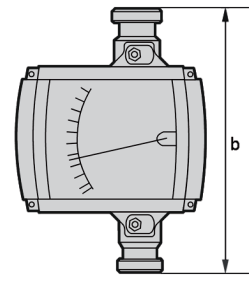

①

① Stainless steel 1.4435
EHEDG approved. Surfaces with medium contact Ra = 0.8 µm

Dimensions of H250/M10 /M8

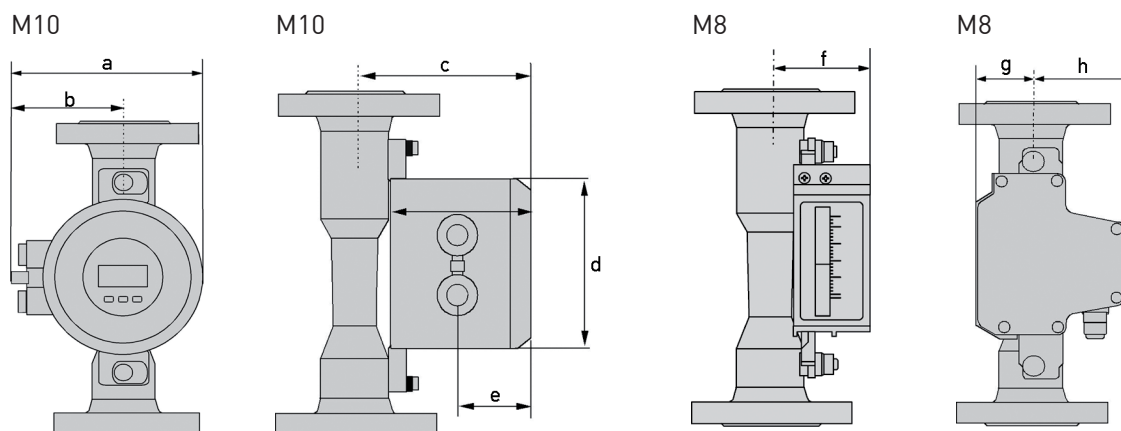

	Dimensions [mm]										
	M10					M8M			M8E		
	a	b	c	d	e	f	g	h	f	g	h
DN15 PN40	147	83	118	Ø 132	55	63	60	58,5	53,5	66	52,5
DN25 PN40	147	83	130	Ø 132	55	75	60	58,5	65,5	66	52,5
DN50 PN40	147	83	143	Ø 132	55	89	73	45,5	79,5	79	39,5
DN80 PN16	147	83	160	Ø 132	55	105	73	45,5	95,5	79	39,5
DN100 PN16	147	83	169	Ø 132	55	114	73	45,5	104,5	79	39,5

Weights

Nominal diameter	H250	with heating		H250/C (Ceramic / PTFE)			Screw connection
	EN 1092-1	Flange connection	Ermeto 12 connection	EN 1092-1	ASME B 16.5 150 lbs	ASME B 16.5 300 lbs	DIN 11864-1
	[kg]						
DN15 / 1/2"	3,5	5,6	5,7	3,5	3,2	3,5	2
DN25 / 1"	5	7,5	7,6	5	5,2	6,8	3,5
DN50 / 2"	8,2	11,2	11,3	10	10	11	5
DN80 / 3"	12,2	14,8	14,9	13	13	15	7,6
DN100 / 4"	14	17,4	17,5	15	16	17	10,3

Process connections

	Standards	Connection dimensions	Pressure rating
Flange (H250/RR /HC /C)	EN-1092-1	DN15...DN100	PN16...PN100
	ASME B16.5	1/2"...4"	150 lbs...600 lbs
	JIS B 2238	LR15...LR100	10K...20K
Clamp connections (H250/RR /F)	DIN 32676	DN15...DN100	10 bar...16 bar
	ISO 2852	Größe 25...139,7	10 bar...16 bar
Threaded connections (H250/RR /HC /F)	DIN 11851	DN15...DN100	25 bar...40 bar
	SMS 1146	1"...4"	6 bar
Inside thread welded (H250/RR /HC)	ISO 228	G1/2"...G2"	≥ PN50
	ASME B1.20.1	1/2"...2" NPT	
Inside thread, screwed (H250/RR /HC) with insert and union nut	ISO 228	G1/2"...2"	PN40...PN50
	ASME B1.20.1	1/2"...2" NPT	
Aseptic threaded connection (H250/F)	DIN 11864 - 1	DN15...DN50	PN40
	-	DN80...DN100	PN16
Aseptic flange (H250/F)	DIN 11864 - 2	DN15...DN50	PN40
	-	DN80...DN100	PN16
Meters (H250/RR /HC) with heating:			
Heating with flange connection	EN 1092-1	DN15	PN40
	ASME B16.5	1/2"	150 lbs / RF
Heating with pipe connection for Ermeto	-	E12	PN40

Bolts and tightening torques

Nominal sizes, EN

Nominal sizes as per EN 1092-1	Bolts		Tightening torques	
	Quantity x size		SI [Nm]	Imp [lb-ft]
DN15 PN40	4 x M12		9,8	7.1
DN25 PN40	4 x M12		21	15
DN50 PN40	4 x M16		57	41
DN80 PN16	8 x M16		47	34
DN100 PN16	8 x M16		67	48

Nominal sizes, ASME

Normal sizes as per ASME B 16.5	Bolts		Tightening torques	
	Quantity x size		SI [Nm]	Imp [lb-ft]
	150 lbs	300 lbs		
½" 150 lbs / 300 lbs	4 x ½"	4 x ½"	5,2	3.8
1" 150 lbs / 300 lbs	4 x ½"	4 x 5/8"	10	7.2
2" 150 lbs / 300 lbs	4 x 5/8"	8 x 5/8"	41	30
3" 150 lbs / 300 lbs	4 x 5/8"	8 x ¾"	70	51
4" 150 lbs / 300 lbs	8 x 5/8"	8 x ¾"	50	36

Measuring ranges

H250/RR - stainless steel, H250/HC - Hastelloy

Measuring span 10 : 1

Flow values 100%

		Water			Air			Max. pressure loss			
Float ▶		TIV	CIV	DIV	TIV Alu	TIV	DIV	TIV Alu	TIV	CIV	DIV
Nominal diameter	Cone	[l/h]			[m ³ /h]			[mbar]			
DN15 1/2"	K 15.1	18	25	-	0,42	0,7	-	12	21	26	-
	K 15.2	30	40	-	0,7	1	-	12	21	26	-
	K 15.3	55	63	-	1	1,5	-	12	21	26	-
	K 15.4	80	100	-	1,7	2,2	-	12	21	26	-
	K 15.5	120	160	-	2,5	3,6	-	12	21	26	-
	K 15.6	200	250	-	4,2	5,5	-	12	21	26	-
	K 15.7	350	400	700	6,7	10	18 ①	12	21	28	38
	K 15.8	500	630	1000	10	14	28 ①	13	22	32	50
DN25 1"	K 15.8	-	-	1600 ②	-	-	50 ②	-	-	-	85
	K 25.1	480	630	1000	9,5	14	-	11	24	32	72
	K 25.2	820	1000	1600	15	23	-	11	24	33	74
	K 25.3	1200	1600	2500	22	35	-	11	25	34	75
	K 25.4	1700	2500	4000	37	50	110 ①	12	26	38	78
DN50 2"	K 25.5	3200	4000	6300	62	95	180 ①	13	30	45	103 ③
	K 55.1	2700	6300	8400	58	80	230 ①	8	13	74	60
	K 55.2	3600	10000	14000	77	110	350 ①	8	13	77	69
DN80 3"	K 55.3	5100	16000	25000	110	150	700 ①	9	13	84	104
	K 85.1	12000	25000	37000	245	350	1000 ①	8	16	68	95
DN100 4"	K 85.2	16000	40000	64000	280	400	1800 ①	9	16	89	125
	K105.1	19000	63000	100 000	-	550	2800 ①	-	-	120	220

① P > 0,5 bar

② with TR float

③ 300 mbar with damping (gas measurement)

Reference condition:

Water 20°C

Air 20°C - 1.013bar abs.

Notes:

- Air measurement - TIV suspended solid particles: Heating not possible
- The indicated pressure losses apply for water and air at maximum flow.
- Other flow rate measuring ranges can be provided upon request.
- The conversion of other process fluids or operating data (pressure, temperature, density, viscosity) is done at KROHNE with the help of the calculation procedure as detailed in VDE /VDI Directive 3513

H250/C - Ceramic/PTFE

Measuring span 10 : 1

Flow values 100%

Liner float ▶		Flow			Max. pressure loss		
		Water		Air	Water		Air
		PTFE	Ceramic	CeramiC	PTFE	Ceramic	Ceramic
Nominal size	Cone	[l/h]		[m ³ /h]	[mbar]		
DN15, 1/2"	E 17.2	25	30	-	65	62	62
	E 17.3	40	50	1,8	66	64	64
	E 17.4	63	70	2,4	66	66	66
	E 17.5	100	130	4	68	68	68
	E 17.6	160	200	6,5	72	70	70
	E 17.7	250	250	9	86	72	72
	E 17.8	400	-	-	111	-	-
	DN25, 1"	E 27.1	630	500	18	70	55
E 27.2		1000	700	22	80	60	60
E 27.3		1600	1100	30	108	70	70
E 27.4		2500	1600	50	158	82	82
E 27.5		4000 ①	2500	75	290	100	100
DN50, 2"	E 57.1	4000	4500	140	81	70	70
	E 57.2	6300	6300	200	110	80	80
	E 57.3	10000	11000	350	170	110	110
	E 57.4	16000 ②	-	-	284	-	-
DN80, 3"	E 87.1	16000	16000	-	81	70	-
	E 87.2	25000	25000	-	95	85	-
	E 87.3	40000 ②	-	-	243	-	-
DN100, 4"	E 107.1	40000	-	-	100	-	-
	E 107.2	60000 ②	-	-	225	-	-

① special fööat

② special float

Reference condition:

Water 20°C

Air 20°C - 1.013bar abs.

Notes:

- The indicated pressure losses apply for water and air at maximum flow.
- Other flow rate measuring ranges can be provided upon request.
- The conversion of other process fluids or operating data (pressure, temperature, density, viscosity) is done at KROHNE with the help of the calculation procedure as detailed in VDE /VDI Directive 3513

H250H - horizontal installation

Measuring span 10 : 1

Flow values 100%

	Float Type	Cone No.	Flow Water [l/h]		Max. pressure loss [mbar]	
			spring A	spring B	spring A	spring B
DN15	DIV TB	K 15.1	70		195	
		K 15.2	120		204	
		K 15.3	180		195	
		K 15.4	280		225	
		K 15.5	450		250	
		K 15.6	700		325	
		K 15.7	1200		590	
		K 15.8	1600	2400	950	1600
DN25	DIV T	K 25.1	1300		122	
		K 25.2	2000		105	
		K 25.3	3000		116	
		K 25.4	5000		145	
		K 25.5	8500	10000	217	336
DN50	DIV T	K 55.1	10000		240	
		K 55.2	16000		230	
		K 55.3	22000	34000	220	420
DN80	DIV T	K 85.1	25000		130	
		K 85.2	35000	60000	130	290
DN100	DIV L	K 105.1	80000	120000	250	340

Reference condition:

Water 20°C

Notes:

- The indicated pressure losses apply for water at maximum flow.
- Other flow rate measuring ranges can be provided upon request.
- Conversion of other process fluids or operating data as detailed in VDE /VDI Directive 3513

H250U - vertical installation

Direction of flow from top down

Measuring span 10 : 1

Flow values 100%

	Float	Cone no.	Flow, water [l/h]	Max. pressure loss [mbar]
DN15	DIV TB	K 15.1	65	175
		K 15.2	110	178
		K 15.3	170	180
		K 15.4	260	200
		K 15.5	420	220
		K 15.6	650	290
		K 15.7	1100	520
		K 15.8	1500	840
DN25	DIV T	K 25.1	1150	97
		K 25.2	1800	85
		K 25.3	2700	92
		K 25.4	4500	115
		K 25.5	7600	172
DN50	DIV T	K 55.1	9000	220
		K 55.2	15000	230
		K 55.3	21000	240

Reference condition:
Water 20°C

Notes:

- The indicated pressure losses apply for water at maximum flow.
- Other flow rate measuring ranges can be provided upon request.
- Conversion of other process fluids or operating data as detailed in VDE /VDI Directive 3513



KROHNE measuring technology - Product overview

- Electromagnetic flowmeters
- Variable area flowmeters
- Mass flowmeters
- Ultrasonic flowmeters
- Vortex flowmeters
- Flow controllers
- Level measuring instruments
- Temperature measuring instruments
- Pressure measuring instruments
- Analysis
- Oil and gas industry

Addresses:

Germany

Northern sales office

KROHNE Messtechnik GmbH & Co. KG
Bremer Str. 133
D-21073 Hamburg
Phone: +49 (0)40 767 3340
Fax: +49 (0)40 767 33412
nord@krohne.com
ZIP code: 10000 - 29999, 49000 - 49999

Western and middle sales office

KROHNE Messtechnik GmbH & Co. KG
Ludwig-Krohne-Straße
D-47058 Duisburg
Phone: +49 (0)203 301 4416
Fax: +49 (0)203 301 10416
west@krohne.com
ZIP code: 30000 - 34999, 37000 - 48000, 50000 - 53999, 57000 - 59999, 98000 - 99999

Southern sales office

KROHNE Messtechnik GmbH & Co. KG
Landsberger Str. 392
D-81241 Munich
Phone: +49 (0)89 121 5620
Fax: +49 (0)89 129 6190
sued@krohne.com
ZIP code: 0 - 9999, 80000 - 89999, 90000 - 97999

Southwestern sales office

KROHNE Messtechnik GmbH & Co. KG
Rüdesheimer Str. 40
D-65239 Hochheim/Main
Phone: +49(0)6146) 827 30
Fax: +49 (0)6146 827 312
rhein-main@krohne.com
ZIP code: 35000 - 36999, 54000 - 56999, 60000 - 79999

Instrumentation and control equipment catalog

TABLAR Messtechnik GmbH
Ludwig-Krohne-Str. 5
D-47058 Duisburg
Phone: +49 (0)2 03 305 880
Fax: +49 (0)2 03 305 8888
kontakt@tablar.de; www.tablar.de

KROHNE sales companies

International

Australia

KROHNE Australia Pty Ltd
Quantum Business Park 10/287
Victoria Rd Rydalmere NSW 2116
Phone: +61 2 8846 1700
Fax: +61 2 8846 1755
krohne@krohne.com.au

Austria

KROHNE Gesellschaft m.b.H.
Modecenterstraße 14
A-1030 Vienna
Phone: +43 (0)1/203 45 32
Fax: +43 (0)1/203 45 32 99
info@krohne.at

Belgium

KROHNE Belgium N.V.
Brusselstraat 320
B-1702 Groot Bijgaarden
Phone: +32 (0)2 4 66 00 10
Fax: +32 (0)2 4 66 08 00
krohne@krohne.be

Brazil

KROHNE Conaut Controles
Automaticos Ltda.
Estrada Das Águas Espraiadas, 230
C.P. 56 06835 - 080 EMBU - SP
Phone: +55 (0)11-4785-2700
Fax: +55 (0)11 4785-2768
conaut@conaut.com.br

China

KROHNE Measurement Instruments
[Shanghai] Co. Ltd., [KMIC]
9th Floor, Xujiahui International
Building

1033 Zhaojiabang Road
Shanghai 200030
Phone: +86 21 6487 9611
Fax: +86 21 6438 7110
info@krohne-asia.com

Czech Republic

Krohne CZ, spol. s r.o.
Soběsická 156
63800 Brno
Phone: +420 (0)545.242 627
Fax: +420 (0)545 220 093
brno@krohne.cz

France

KROHNE S.A.S.
Les Ors BP 98
F-26103 ROMANS Cedex
Phone: +33 (0)4 75 05 44 00
Fax: +33 (0)4 75 05 00 48
info@krohne.fr

Great Britain

KROHNE Ltd.
Rutherford Drive
Park Farm Industrial Estate
Wellingborough
Northants NN8 6AE
Phone: +44 (0)19 33 408 500
Fax: +44 (0)19 33 408 501
info@krohne.co.uk

CIS

Kanex KROHNE Engineering AG
Business-Centre Planeta
Office 404 ul.
Marxistskaja 3
109147 Moscow/Russia
Phone: +7 (0)095 911 7165
Fax: +7 (0)095 742 8873
krohne@dol.ru

India

Krohne Marshall Ltd.
A-34/35, M.I.D.C. Industrial Area,
H-Block
Pimpri Poona 411018
Phone: +91 (0)202 744 2020
Fax: +91 (0)202 744 2020
pcui@vsnl.net

Iran

KROHNE Liaison Office
North Sohrvardi Ave. 26,
Sarmad St., Apt. #9
Tehran 15539
Phone: +9821 8874 5973
Fax: +9821 8850 1268
krohne@krohneiran.com

Italy

KROHNE Italia Srl.
Via V. Monti 75
I-20145 Milan
Phone: +39 02 4300 661
Fax: +39 02 4300 6666
info@krohne.it

Korea

KROHNE Korea
Room 508 Miwon Bldg 43
Yoido-Dong Youngdeungpo-Ku
Seoul, Korea
Phone: 00-82-2-782-1900
Fax: 00-82-2-780-1749
mail@krohne.co.kr

Netherlands

KROHNE Nederland B.V.
Kerkeplaat 14
NL-3313 LC Dordrecht
Phone: +31 (0)78 630 6200
Fax: +31 (0)78 630 6405
Service Direct: +31 (0)78 630 6222
info@krohne.nl

Norway

KROHNE Norway A.S.
Ekholtveien 114
NO-1521 Moss
Phone: +47 (0)69 264 860
Fax: +47 (0)69 267 333
postmaster@krohne.no

Poland

KROHNE Polska Sp.z.o.o.
ul. Stary Rynek Oliwski 8a
80-324 Gdansk
Phone: +48 (0)58 520 9211
Fax: +48 (0)58 520 9212
info@krohne.pl

Switzerland

KROHNE AG
Uferstr. 90
CH-4019 Basel
Phone: +41 (0)61 638 30 30
Fax: +41 (0)61 638 30 40
info@krohne.ch

Singapore

Tokyo Keiso - KROHNE (Singapore)
Pte. Ltd.
14, International Business Park,
Jurong East
Chiyoda Building, #01-01/02
Singapore 609922
Phone: (65) 6567 4548
Fax : (65) 6567 9874
tks@tokyokeiso-krohne.com.sg

Republic of South Africa

KROHNE Pty. Ltd.
Bushbuck Close
Corporate Park South
Midrand, Gauteng
P.O. Box 2069
Midrand, 1685
Tel.: +27 (0)11 314 1391
Fax: +27 (0)11 314 1681
midrand@krohne.co.za

Spain

I.I. KROHNE IBERIA, S.r.l.
Polígono Industrial Nilo
Calle Brasil, nº. 5
28806 Alcalá de Henares Madrid
Phone: +34 (0)91 883 2152
Fax: +34 (0)91 883 4854
krohne@krohne.es

USA

KROHNE, Inc.
7 Dearborn Road
Peabody, MA 01960
Phone: +1 (800) FLOWING
Phone: +1 (978) 535 6060 (in MA)
info@krohne.com

Representatives

Algeria
Argentina
Cameroon
Canada
Chile
Columbia
Croatia
Denmark
Ecuador
Egypt
Finland
Gabon
Ghana
Greece
Hong Kong
Hungary
Indonesia
Iran
Ireland
Israel
Ivory Coast
Japan
Jordan
Kuwait
Libya
Lithuania
Malaysia
Mauritius
Mexico
Morocco
New Zealand
Peru
Portugal
Romania
Saudi Arabia
Senegal
Slovakia
Slovenia
Sweden
Taiwan
Thailand
Tunisia
Turkey
Venezuela
Yugoslavia

Other countries

KROHNE Messtechnik GmbH & Co. KG
Ludwig-Krohne-Str. 5
D-47058 Duisburg
Phone: +49 (0)203 301 0
Fax: +49 (0)203 301 389
export@krohne.com