



POWERFLUX 4000 Technical Datasheet

Electromagnetic flow sensor

- Robust, fully welded construction
- Constructed and tested for nuclear environments
- Full bore construction



The documentation is only complete when used in combination with the relevant documentation for the signal converter.

1	Product features	3
<hr/>		
1.1	The reliable solution for nuclear environments.....	3
1.2	Options.....	5
1.3	Measuring principle.....	6
2	Technical data	7
<hr/>		
2.1	Technical data.....	7
2.2	Measurement accuracy.....	11
2.3	Dimensions and weights.....	12
3	Installation	15
<hr/>		
3.1	Intended use.....	15
3.2	General notes on installation.....	15
3.2.1	Vibration.....	15
3.2.2	Magnetic field.....	15
3.3	Installation conditions.....	16
3.3.1	Inlet and outlet.....	16
3.3.2	Bends in 2 or 3 dimensions.....	16
3.3.3	T-section.....	16
3.3.4	Bends.....	17
3.3.5	Open feed or discharge.....	18
3.3.6	Pump.....	18
3.3.7	Control valve.....	18
3.3.8	Air venting and vacuum forces.....	19
3.3.9	Flange deviation.....	20
3.3.10	Mounting position.....	20
3.4	Mounting.....	21
3.4.1	Torques and pressures.....	21
4	Electrical connections	24
<hr/>		
4.1	Safety instructions.....	24
4.2	Grounding.....	24
4.3	Virtual reference for IFC 300 (W and F version).....	26
4.4	Connection diagrams.....	26
5	Notes	27
<hr/>		

1.1 The reliable solution for nuclear environments.

The **POWERFLUX 4000** is an electromagnetic flow sensor specifically constructed for radiation areas.

All the used materials for construction of the flow sensor are selected and tested to meet the demands for the use in nuclear environments.

The fully welded construction has proven itself with a huge track record of applications in the most hostile and demanding environments.

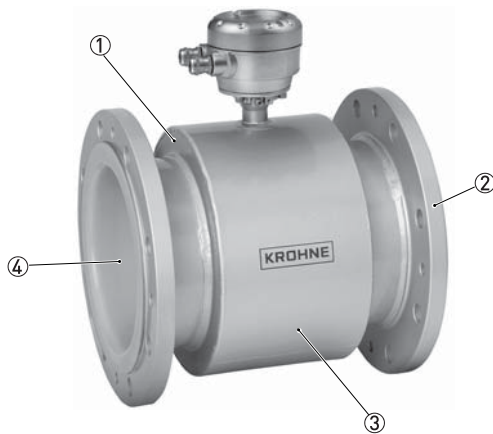

- ① Robust fully welded construction
- ② Diameter range: DN2.5...DN1000
- ③ Hastelloy, titanium, tantalum, stainless steel, platinum and low noise electrodes
- ④ Available with ETFE or PFA liner

Highlights

- Chemical resistant ETFE liner
- Reliable and well proven construction
- Constructed & tested for nuclear environments

Industries

- Nuclear

Applications

- Cooling water
- Transport water
- Borated water
- Spent resin
- Sea water

1.2 Options



The **POWERFLUX 4000** is available from DN2.5 up to DN1000 with a large range of pressure ratings. Two signal converters can be combined with the POWERFLUX 4000: the powerful and high end IFC 300 and the fully analogue AFC 030 converter.

1.3 Measuring principle

An electrically conductive fluid flows inside an electrically insulated pipe through a magnetic field. This magnetic field is generated by a current, flowing through a pair of field coils.

Inside of the fluid, a voltage U is generated:

$$U = v * k * B * D$$

in which:

v = mean flow velocity

k = factor correcting for geometry

B = magnetic field strength

D = inner diameter of flowmeter

The signal voltage U is picked off by electrodes and is proportional to the mean flow velocity v and thus the flow rate Q . A signal converter is used to amplify the signal voltage, filter it and convert it into signals for totalizing, recording and output processing.

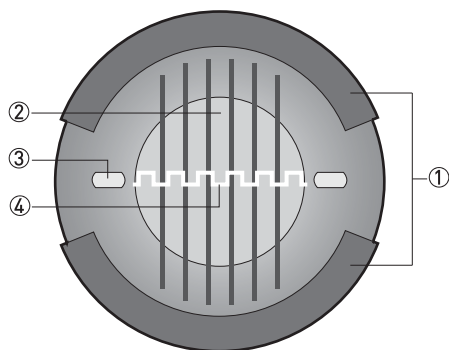

Figure 1-1: Measuring principle

- ① Field coils
- ② Magnetic field
- ③ Electrodes
- ④ Induced voltage (proportional to flow velocity)

2.1 Technical data

- The following data is provided for general applications. If you require data that is more relevant to your specific application, please contact us or your local sales office.
- Additional information (certificates, special tools, software,...) and complete product documentation can be downloaded free of charge from the website (Downloadcenter).

Measuring system

Measuring principle	Faraday's law
Application range	Electrically conductive fluids
Measured value	
Primary measured value	Flow velocity
Secondary measured value	Volume flow

Design

Features	Fully welded maintenance-free sensor.
	Flange version with full bore flow tube.
	Standard as well as higher pressure ratings.
	Broad range of nominal sizes.
	Industry specific insertion lengths.
Modular construction	The measurement system consists of a flow sensor and a signal converter. It is only available as a separate version.
Remote version	With AFC 030 converter: POWERFLUX 4030 W In field (F) version with IFC 300: POWERFLUX 4300 F
Nominal diameter	DN25...1000 / 1...40"

Measuring accuracy	
Maximum measuring error	These values are related to the pulse / frequency output.
	Related to volume flow (MV = Measured Value)
	With AFC 030 converter:
	DN2.5:...1000 \pm 1% of MV + 2.5 mm/s
	With IFC 300 converter:
	DN2.5:...15 \pm 0.3% of MV + 2 mm/s
	DN25:...1000 \pm 0.2% of MV + 1 mm/s
	The additional typical measuring deviation for the current output is \pm 10 μ A.
The maximum measuring error depends on the installation conditions.	
	For detailed information refer to refer to <i>Measurement accuracy</i> on page 11
Repeatability	\pm 0.5% of MV, minimum 1 mm/s
Calibration	Standard:
	Two point calibration by direct volume comparison.
Long term stability	\pm 0.3% of MV
Special calibration / Verification	On request.

Operating conditions

Temperature	
Process temperature	ETFE: -40...+120°C / -40...+248°F PFA: -40...+180°C / -40...+356°F
Ambient temperature	Standard (with stainless steel connection box) : -40...+55°C / -40...+130°F
Storage temperature	-50...+70°C / -58...+158°F
Measurement range	-12...+12 m/s / -40...+40 ft/s
Pressure	
EN 1092-1	DN200...700: PN 10
	DN65 and DN100...150: PN 16
	DN2.5...50 and DN80: PN 40
	Other pressures on request.
ASME B16.5	1/10...24": 150 lb RF
	Other pressures on request.
JIS	DN50...1000: 10 K
	DN2.5...40: 20 K
	Other pressures on request.
Vacuum load	ETFE:
	100 mbara (+40...+120°C), P _{max} ; 150 bar
	1.5 psia (+104...+248°F), P _{max} ; 2176 psi
	PFA
	0 mbara (+40...+180°C), P _{max} ; 50 bar
0 psia (+104...+356°F), P _{max} ; 725 psi	
Pressure loss	Negligible

Chemical properties	
Physical condition	Electrically conductive liquids
Electrical conductivity	Water: ≥ 20 μS/cm
	Other than water: ≥ 1 μS/cm

Installation conditions

Installation	Assure that the flow sensor is always fully filled.
	For detailed information refer to <i>Installation</i> on page 15
Flow direction	Forward and reverse.
	Arrow on flow sensor indicates positive flow direction.
Inlet run	≥ 5 DN
Outlet run	≥ 2 DN
Dimensions and weights	For detailed information refer to <i>Dimensions and weights</i> on page 12

Materials

Sensor housing	Standard: Stainless steel
	Other materials on request.
Measuring tube	Austenitic stainless steel
Flanges	Standard: Stainless steel
	Other materials on request.
Liner	Standard: ETFE, DN25...1000
	Option: PFA, DN2.5...15
Protective coating	On exterior of the meter: flanges, housing, signal converter (compact version) and / or connection box (field version)
	Standard: siloxane coating
	according: ISO 12944-2 :2007 Category 3, Medium / C4 Low
Connection box	Stainless steel
Measuring electrodes	Standard: Hastelloy [®] C
	Option: Platinum, stainless steel, titanium, tantalum, low noise
	Other materials on request.
Grounding rings	Standard : Stainless steel
	Option: Hastelloy [®] C, titanium, tantalum
	Grounding rings can be omitted with virtual reference option for the IFC 300 converter.
Reference electrode (optional)	Standard: Hastelloy [®] C
	Option: Platinum, stainless steel, titanium, tantalum, low noise
	Other materials on request.

Process connections

Flange	
EN 1092-1	DN2.5...1000 in PN 6...40
ASME	1/10...40" in 150...900 lbs RF
JIS	DN2.5...1000 in JIS 10...20 K
Design of gasket surface	RF
	Other sizes or pressure ratings on request.

Electrical connections	
Signal cable	
Type A (DS and DS-L)	<p>In combination with the IFC 300 and AFC 030 signal converter</p> <p>Standard cable, double shielded. Max. length: 600 m / 1950 ft (dep. on electrical conductivity and measuring sensor).</p> <p>For detailed information refer to the documentation of the relevant signal converter.</p>
Type B (BTS)	<p>In combination with the IFC 300 signal converter</p> <p>Optional cable, triple shielded. Max. length: 600 m / 1950 ft (dep. on electrical conductivity and measuring sensor).</p> <p>For detailed information refer to the documentation of the relevant signal converter.</p>
I/O	For full details of I/O options, including data streams and protocols, see the technical data sheet of the relevant signal converter.
Others	For detailed information of the connection cables of the AFC 030 see the manual of the signal converter.

Approvals and certificates	
CE	
This device fulfills the statutory requirements of the EU directives. The manufacturer certifies successful testing of the product by applying the CE mark.	
	For full information of the EU directives & standards and the approved certifications, please refer to the CE declaration or the manufacturer website.
Nuclear approvals	
EMC	IEC 61000-4
Radiation	ETFE: TID 5E+06 Rad
	PFA: TID 1E+06 Rad
Vibration	EN 60068-2-6
Seismic	IEC 60980 - 1989 [300 m/s ²]
Fire	Nf C32-070: C1 (on request, for non-standard cably only)
Other approvals and standards	
Protection category acc. to IEC 529 / EN 60529	Standard:
	IP 66/67 (NEMA 4/4X/6)
Vibration resistance	IEC 68-2-64
Random vibration test	IEC 68-2-34
Shock test	IEC 68-2-27

2.2 Measurement accuracy

Every electromagnetic flowmeter is calibrated by direct volume comparison. The wet calibration validates the performance of the flowmeter under reference conditions against accuracy limits.

The accuracy limits of electromagnetic flowmeters are typically the result of the combined effect of linearity, zero point stability and calibration uncertainty.

Reference conditions

- Medium: water
- Temperature: +5...35°C / +41...95°F
- Operating pressure: 0.1...5 barg / 1.5...72.5 psig
- Inlet section: ≥ 5 DN
- Outlet section: ≥ 2 DN

IFC 300 accuracy

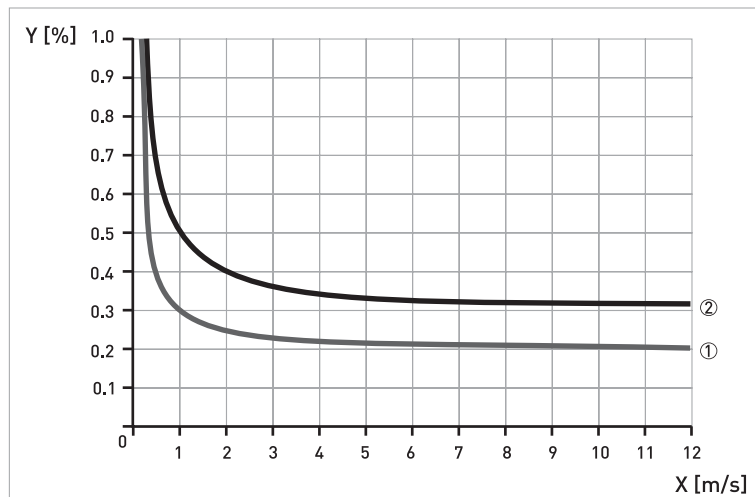

Figure 2-1: X [m/s] : flow velocity
Y [%]: deviation from the actual measured value (mv)

AFC 030 accuracy

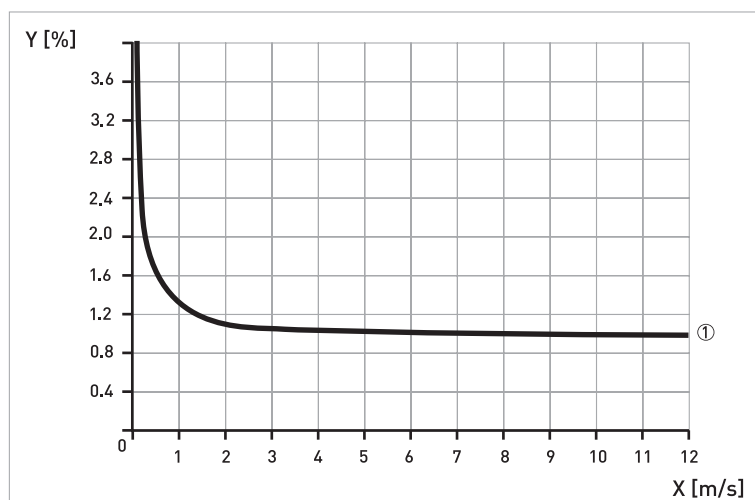

Figure 2-2: X [m/s] : flow velocity
Y [%]: deviation from the actual measured value (mv)

- ① Minimal accuracy for DN10...1000
- ② Minimal accuracy for DN2.5...6

2.3 Dimensions and weights

	a = 88 mm / 3.5"
	b = 139 mm / 5.5" ①
	c = 106 mm / 4.2"
	Total height = H + a

① The value may vary depending on the used cable glands.

- All data given in the following tables are based on standard versions of the flow sensor only.
- Especially for smaller nominal sizes of the flow sensor, the signal converter can be bigger than the flow sensor.
- Note that for other pressure ratings than mentioned, the dimensions may be different.
- For full information on signal converter dimensions see relevant documentation.

EN 1092-1

Nominal size		Dimensions [mm]				Approx. weight [kg]
DN	PN [bar]	L		H	W	
		PFA	EFTE			
2.5...6	40	130	-	142	90	3
10	40	130 ①	-	106	90	6
15	40	130 ①	-	106	95	6
25	40	-	200	140	115	4
32	40	-	250	157	140	5
40	40	-	250	166	150	5
50	40	-	250	186	165	9
65	16	-	250	200	185	9
80	40	-	250	209	200	12
100	16	-	250	237	220	15
125	16	-	300	266	250	19
150	16	-	300	300	285	27
200	10	-	350	361	340	34
250	10	-	400	408	395	48
300	10	-	500	458	445	58
350	10	-	500	510	505	78
400	10	-	600	568	565	101
450	10	-	600	618	615	111
500	10	-	600	671	670	130
600	10	-	600	781	780	165
700	10	-	700	898	895	248
800	10	-	800	1012	1015	331
900	10	-	900	1114	1115	430
1000	10	-	1000	1225	1230	507

150 lb flanges

Nominal size		Dimensions [inches]				Approx. weight [lb]
ASME	PN [psi]	L		H	W	
		PFA	ETFE			
1/10 ... 1/4	284	5.12	-	5.59	3.50	6
3/8 ... 1/2	284	5.12 ①	-	5.08	3.50	6
3/4	284	5.91	-	5.28	3.50	6
1"	284	-	7.87	5.39	4.25	7
1 1/4"	284	-	9.84	5.98	4.62	7
1 1/2"	284	-	9.84	6.10	5.00	11
2"	284	-	9.84	7.05	5.98	18
2 1/2"	284	-	9.84	7.72	7.00	24
3"	284	-	9.84	8.03	7.50	26
4"	284	-	9.84	9.49	9.00	40
5"	284	-	11.81	10.55	10.0	49
6"	284	-	11.81	11.69	11.0	64
8"	284	-	13.78	14.25	13.5	95
10"	284	-	15.75	16.3	16.0	143
12"	284	-	19.69	18.78	19.0	207
14"	284	-	27.56	20.67	21.0	284
16"	284	-	31.50	22.95	23.5	364
18"	284	-	31.50	24.72	25.0	410
20"	284	-	31.50	26.97	27.5	492
24"	284	-	31.50	31.38	32.0	675

- Pressures at 20°C / 68°F.
- For higher temperatures, the pressure and temperature ratings are as per ASME B16.5.

300 lb flanges

Nominal size		Dimensions [inches]				Approx. weight [lb]
ASME	PN [psi]	L		H	W	
		PFA	ETFE			
1/10 ... 1/4	741	5.12	-	5.59	3.75	6
3/8 ... 1/2	741	5.12 ①	-	5.24	3.75	6
3/4	741	5.91	-	5.67	3.75	6
1"	741	-	9.84	5.71	4.87	11
1 1/2"	741	-	11.81	6.65	6.13	13
2"	741	-	11.81	7.32	6.50	22
3"	741	-	11.81	8.43	8.25	31
4"	741	-	11.81	10.00	10.0	44
6"	741	-	13.78	12.44	12.5	73
8"	741	-	15.75	15.04	15.0	157
10"	741	-	19.69	17.05	17.5	247
12"	741	-	23.62	20.00	20.5	375
14"	741	-	27.56	21.65	23.0	474
16"	741	-	31.50	23.98	25.5	639
20"	741	-	31.50	28.46	30.5	937
24"	741	-	31.50	33.39	36.0	1345

- Pressures at 20°C / 68°F.
- For higher temperatures, the pressure and temperature ratings are as per ASME B16.5.

3.1 Intended use

Responsibility for the use of the measuring devices with regard to suitability, intended use and corrosion resistance of the used materials against the measured fluid lies solely with the operator.

The manufacturer is not liable for any damage resulting from improper use or use for other than the intended purpose.

The measurement of volumetric flowrate of electrically conductive fluids. Basic measurement is the flow velocity upon which all other measurements are based.

3.2 General notes on installation

Inspect the packaging carefully for damages or signs of rough handling. Report damage to the carrier and to the local office of the manufacturer.

Do a check of the packing list to make sure that you have all the elements given in the order.

Look at the device nameplate to ensure that the device is delivered according to your order. Check for the correct supply voltage printed on the nameplate.

3.2.1 Vibration

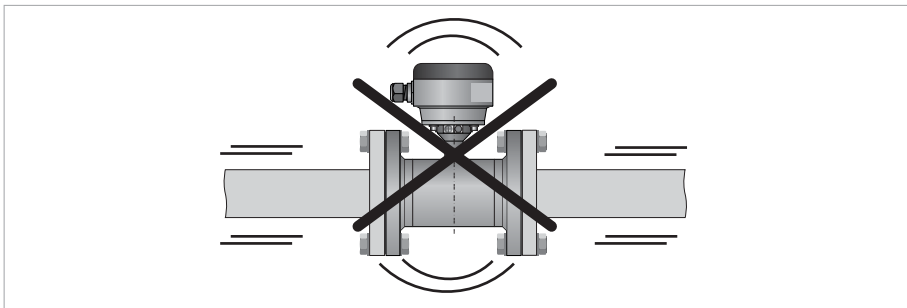

Figure 3-1: Avoid vibrations

3.2.2 Magnetic field

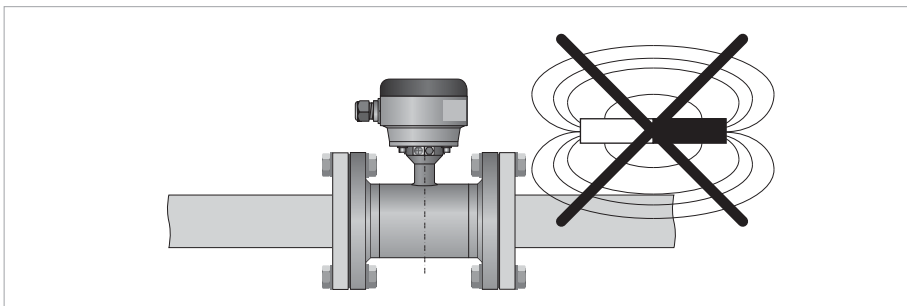

Figure 3-2: Avoid magnetic fields

3.3 Installation conditions

Install in a slightly descending pipe section to prevent air from collecting and to avoid faulty measurements (meter can drain).

3.3.1 Inlet and outlet

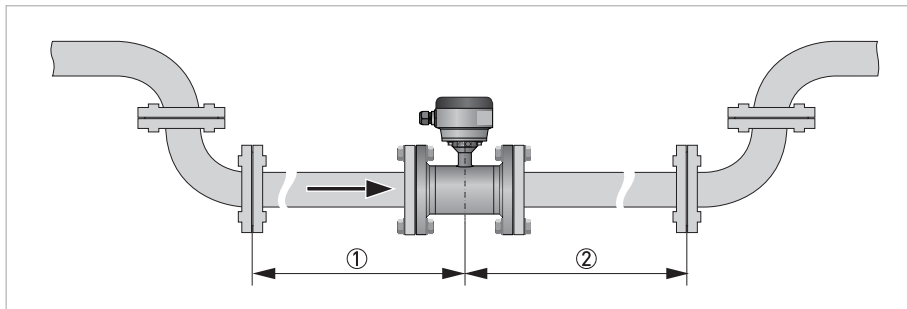

Figure 3-3: Recommended inlet and outlet

- ① Refer to chapter "Bends in 2 or 3 dimensions"
- ② ≥ 2 DN

3.3.2 Bends in 2 or 3 dimensions

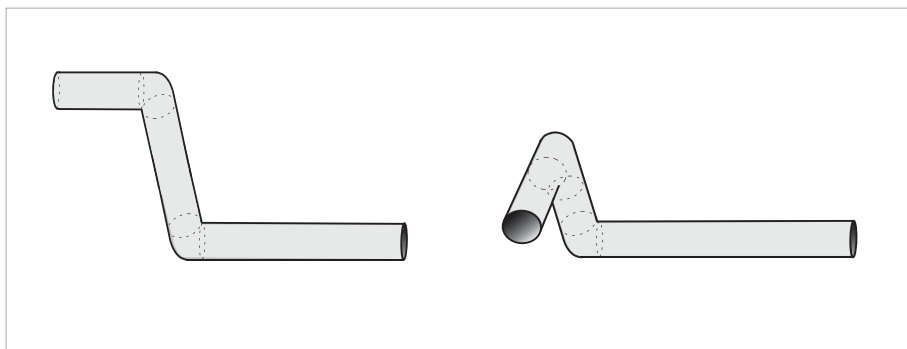

Figure 3-4: Inlet when using 2 and/or 3 dimensional bends in front of the flowmeter

Inlet length: using bends in 2 dimensions: ≥ 5 DN; when having bends in 3 dimensions: ≥ 10 DN

3.3.3 T-section

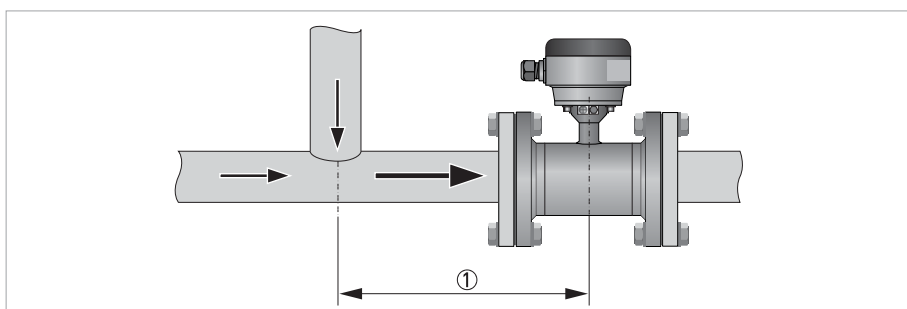

Figure 3-5: Distance behind a T-section

- ① ≥ 10 DN

3.3.4 Bends

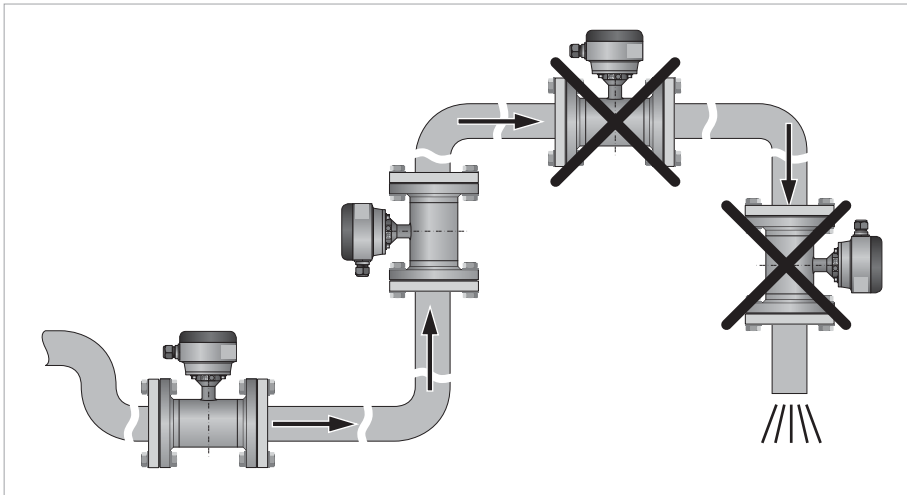

Figure 3-6: Installation in bending pipes

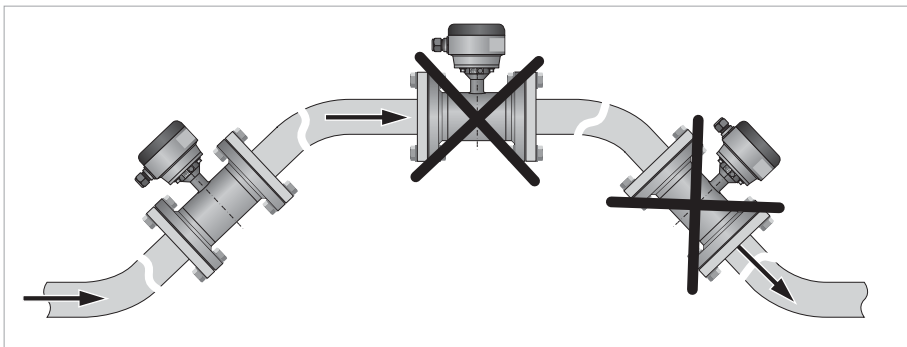

Figure 3-7: Installation in bending pipes

Avoid draining or partial filling of the flow sensor

3.3.5 Open feed or discharge

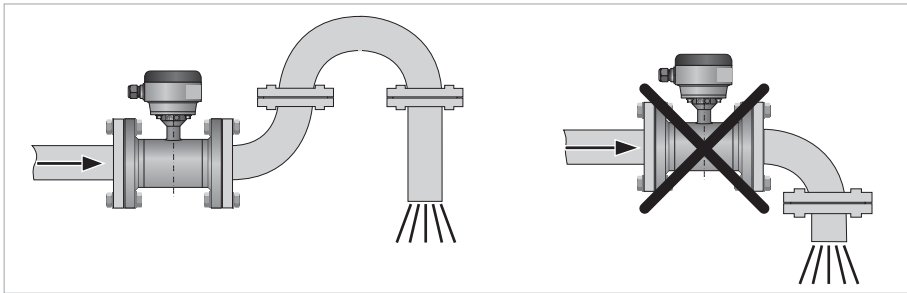

Figure 3-8: Installation in front of an open discharge

3.3.6 Pump

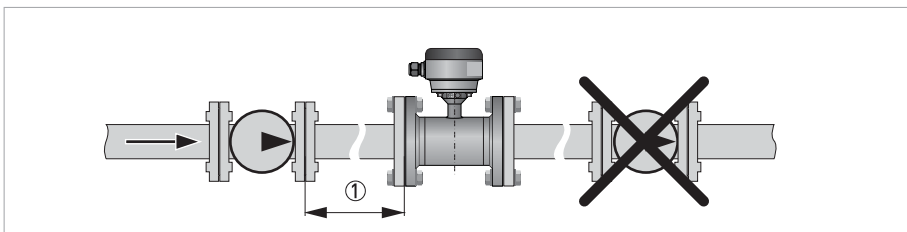

Figure 3-9: Installation behind a pump

① Inlet: ≥ 3 DN

3.3.7 Control valve

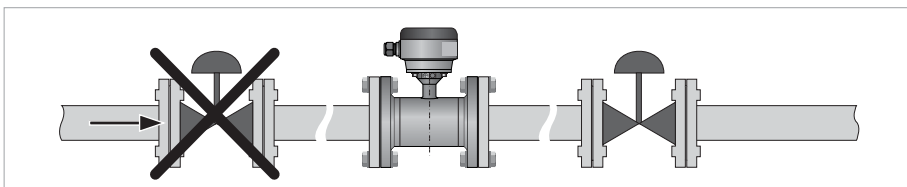

Figure 3-10: Installation in front of a control valve

3.3.8 Air venting and vacuum forces

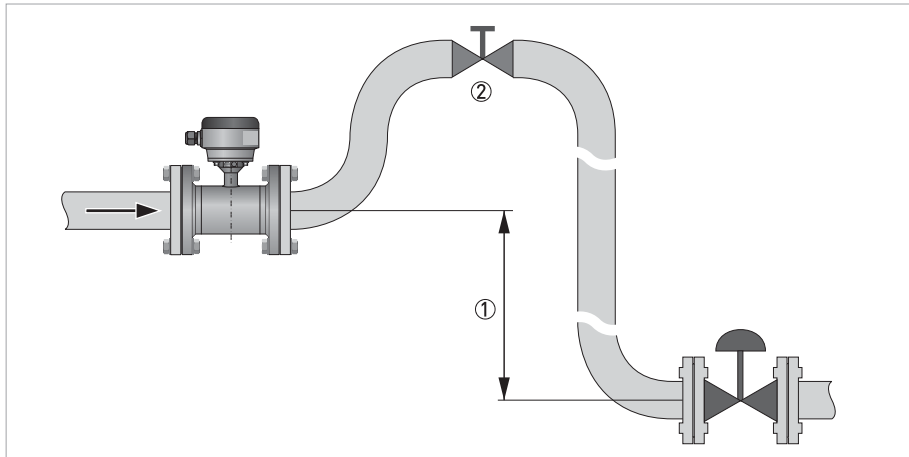

Figure 3-11: Air venting

① ≥ 5 m

② Air ventilation point

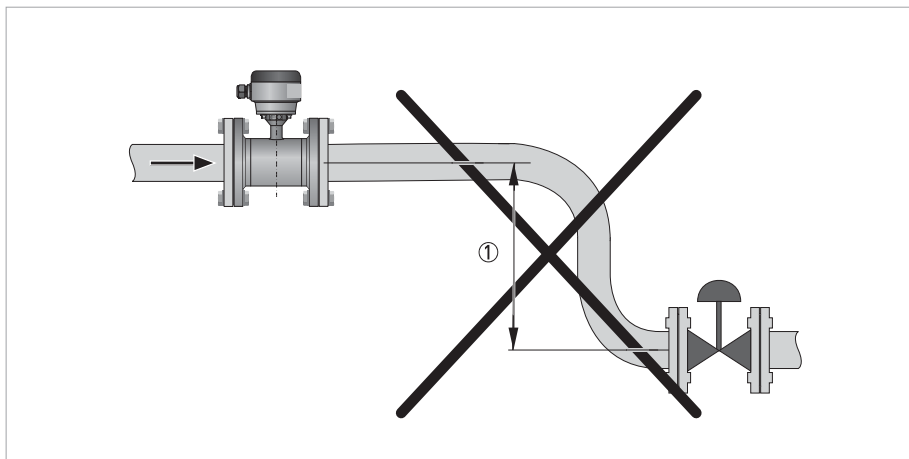

Figure 3-12: Vacuum

① ≥ 5 m

3.3.9 Flange deviation

Max. permissible deviation of pipe flange faces:
 $L_{max} - L_{min} \leq 0.5 \text{ mm} / 0.02''$

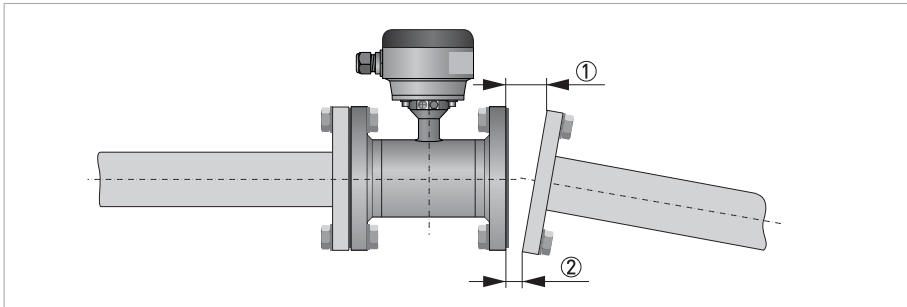

Figure 3-13: Flange deviation

- ① L_{max}
- ② L_{min}

3.3.10 Mounting position

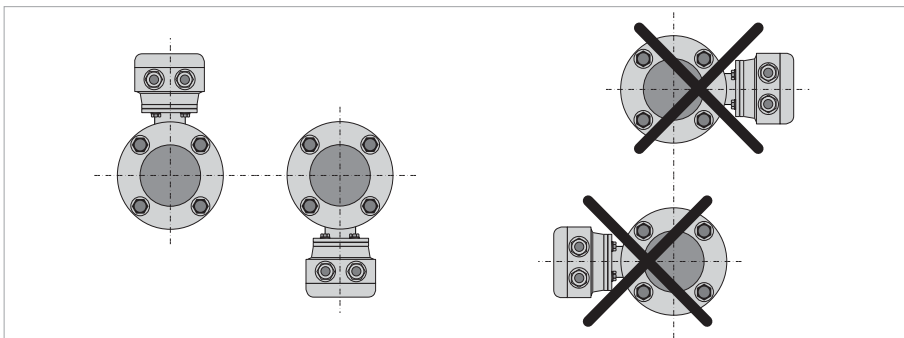

Figure 3-14: Mounting position

- Mount flow sensor either with signal converter aligned upwards or downwards.
- Install flow sensor in line with the pipe axis.
- Pipe flange faces must be parallel to each other.

3.4 Mounting

**CAUTION!**

Please take care to use the proper gasket to prevent damaging the liner of the flowmeter. In general, the use of spiral wound gaskets is not advised, as it could severely damage the liner of the flowmeter.

3.4.1 Torques and pressures

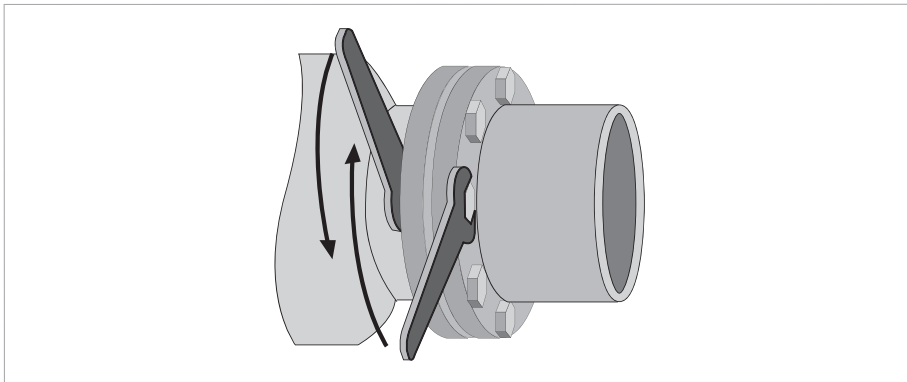

Figure 3-15: Tightening of bolts

Tightening of bolts

- Always tighten the bolts uniformly and in diagonally opposite sequence.
- Do not exceed the maximum torque value.
- Step 1: Apply approx. 50% of max. torque given in table.
- Step 2: Apply approx. 80% of max. torque given in table.
- Step 3: Apply 100% of max. torque given in table.

Other sizes / pressure ratings on request.

Nominal size DN [mm]	Pressure rating	Bolts	Max. torque [Nm] ①
2.5...6	PN 40	4 x M 12	32
10	PN 40	4 x M 12	7.6
15	PN 40	4 x M 12	9.3
25	PN 40	4 x M 12	22
32	PN 40	4 x M 16	37
40	PN 40	4 x M 16	43
50	PN 40	4 x M 16	55
65	PN 16	4 x M 16	51
65	PN 40	8 x M 16	38
80	PN 40	8 x M 16	47
100	PN 16	8 x M 16	39
125	PN 16	8 x M 16	53
150	PN 16	8 x M 20	68
200	PN 10	8 x M 20	84
200	PN 16	12 x M 20	68
250	PN 10	12 x M 20	78
250	PN 16	12 x M 24	116
300	PN 10	12 x M 20	88
300	PN 16	12 x M 24	144
350	PN 10	16 x M 20	97
400	PN 10	16 x M 24	139
450	PN 10	20 x M 24	127
500	PN 10	20 x M 24	149
600	PN 10	20 x M 27	205
700	PN 10	20 x M 27	238
800	PN 10	24 x M 30	328
900	PN 10	28 x M 30	308
1000	PN 10	28 x M 35	392

① The specified torque values are dependent on variables (temperature, bolt material, gasket material, lubricants, etc.) which are not within the control of the manufacturer. Therefore the values should be regarded as indicative only.

Values are based on: F= ASTM gr B7 Studbolts - F=0.14 - Carbon steel flanges

Nominal size [inch]	Flange class [lb]	Bolts	Max. torque [in-lb] ①
1/10, 3/8, 1/4, 3/4	150	4 x 1/2"	39
1/2	150	4 x 1/2"	34
3/4	150	4 x 1/2"	50
1	150	4 x 1/2"	67
1 1/4	150	4 x 1/2"	97
1 1/2	150	4 x 1/2"	138
2	150	4 x 5/8"	225
3	150	4 x 5/8"	43
4	150	8 x 5/8"	34
6	150	8 x 3/4"	61
8	150	8 x 3/4"	979
10	150	12 x 7/8"	1104
12	150	12 x 7/8"	1478
14	150	12 x 1"	1835
16	150	16 x 1"	1767
18	150	16 x 1 1/8"	2605
20	150	20 x 1 1/8"	2365
24	150	20 x 1 1/4"	3419
28	150	28 x 1 1/4"	2904
32	150	28 x 1 1/2"	4560
36	150	32 x 1 1/2"	② *
40	150	36 x 1 1/2"	② *

① The specified torque values are dependent on variables (temperature, bolt material, gasket material, lubricants, etc.) which are not within the control of the manufacturer. Therefore the values should be regarded as indicative only.

Values are based on: F= ASTM gr B7 Studbolts - F=0.14 - Carbon steel flanges

② Information * ; please contact the support service department

Other sizes / pressure ratings on request.

- Pressures are applicable at 20°C / 68°F.
- For higher temperatures, the pressure ratings are as per ASME B16.5.

4.1 Safety instructions

All work on the electrical connections may only be carried out with the power disconnected. Take note of the voltage data on the nameplate!

Observe the national regulations for electrical installations!

Observe without fail the local occupational health and safety regulations. Any work done on the electrical components of the measuring device may only be carried out by properly trained specialists.

Look at the device nameplate to ensure that the device is delivered according to your order. Check for the correct supply voltage printed on the nameplate.

4.2 Grounding

The device must be grounded in accordance with regulations in order to protect personnel against electric shocks.

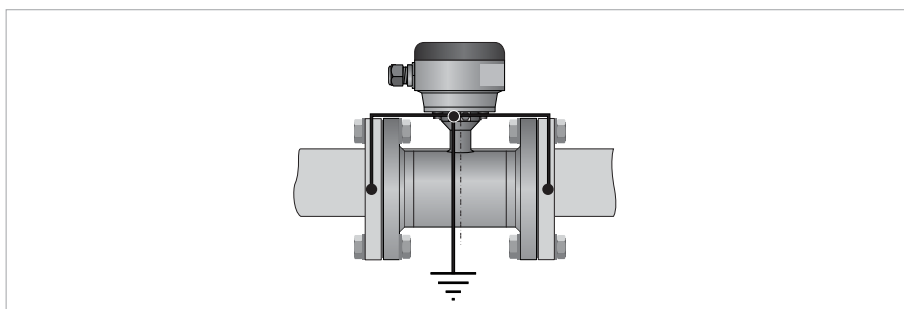

Figure 4-1: Grounding

① Metal pipelines, not internally coated. Grounding without grounding rings.

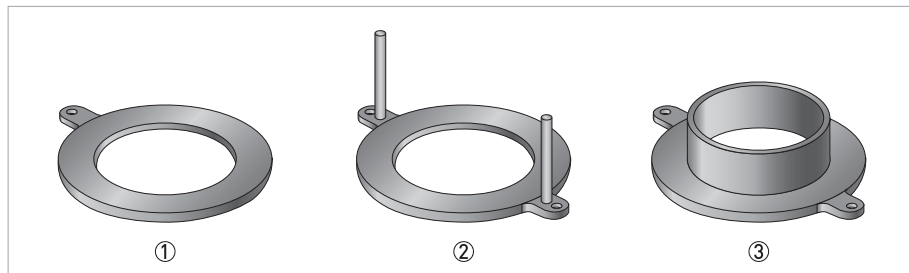

Figure 4-2: Different types of grounding rings

- ① Grounding ring number 1
- ② Grounding ring number 2
- ③ Grounding ring number 3

Grounding ring number 1:

- thickness : 3 mm / 0.1" (tantalum: 0.5 mm / 0.02")

Grounding ring number 2:

- thickness : 3 mm / 0.1"
- Prevents damage to the flanges during transport and installation
- Especially for flow sensors with PTFE liner

Grounding ring number 3:

- thickness : 3 mm / 0.1"
- With cylindrical neck (length 30 mm / 1.25" for DN10...150 / 3/8...6")
- Offers liner protection against abrasive fluids

4.3 Virtual reference for IFC 300 (W and F version)

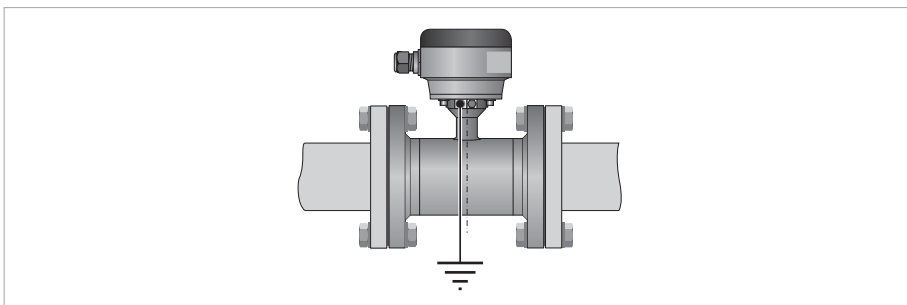

Figure 4-3: Virtual reference

Minimum requirements:

- Size: \geq DN10
- Electrical conductivity: \geq 200 μ S/cm
- Signal cable: max. 50 m / 164 ft, type DS

4.4 Connection diagrams

For the connection diagrams please refer to the documentation of the applicable signal converter.



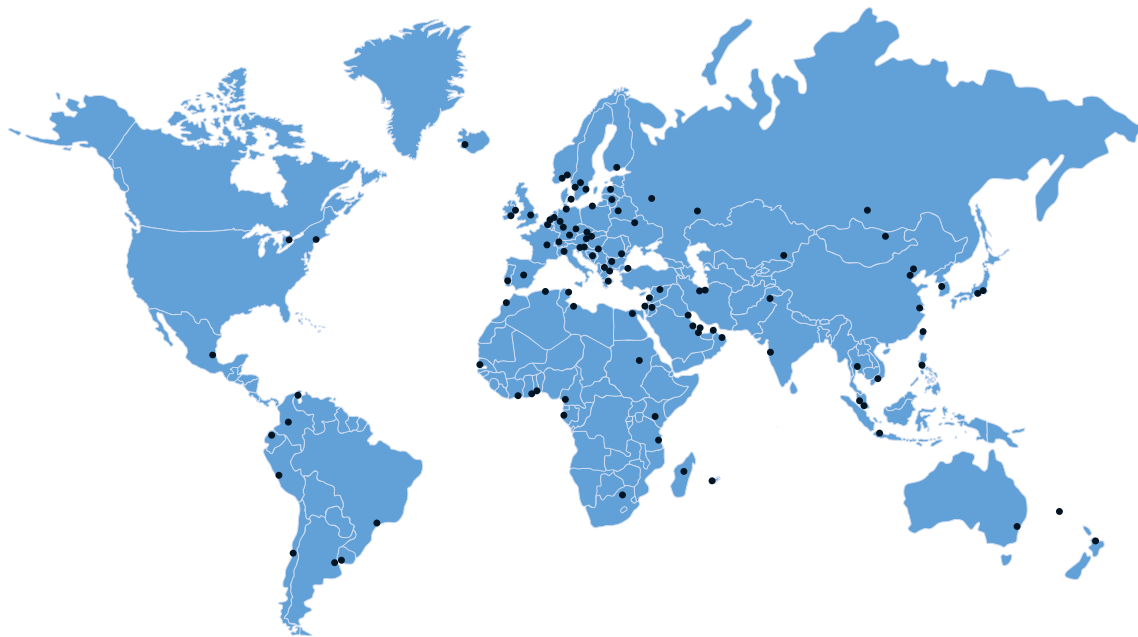

KROHNE – Process instrumentation and measurement solutions

- Flow
- Level
- Temperature
- Pressure
- Process Analysis
- Services

Head Office KROHNE Messtechnik GmbH
Ludwig-Krohne-Str. 5
47058 Duisburg (Germany)
Tel.: +49 203 301 0
Fax: +49 203 301 10389
info@krohne.com

The current list of all KROHNE contacts and addresses can be found at:
www.krohne.com

KROHNE